

# OVERCOME CHALLENGES WITH READING ROCK SOLUTIONS

Adapting to change resonates the history of the buildings that house the Agricultural College. Founded in 1908, the buildings experienced yet another iteration that will welcome students for several more centuries.

## The challenge

King Hall, within the Abraham Baldwin Agricultural College, was undergoing renovations to accommodate 6 classrooms and 12 offices. The building was originally built at the turn of the century when ornamental accents were often made from wood. In addition to the challenge of replicating the ornate entry, there was a requirement to do so in a material that would not produce the ongoing maintenance issues which resulted in the degradation of the original wood portico.

## The solution

RockCast Lightweight masonry was chosen, giving the design and installation team the opportunity to recreate the King Hall's entrance to match the existing façade. The Lightweight profiles are produced with a foam core, encased in an engineered concrete coating, achieving the graceful aesthetic of natural stone. With a foam core, the accent pieces weighed 60%-80% less than natural or cast stone, allowing the designer to use a masonry product without having to structurally carry the weight.

Using the original accent pieces from the building's entrance, the skilled craftsmen in the RockCast mold shop utilized a variety of materials and tools to build a mold to replicate the original wood accents. This task was challenging due to the extreme rotting and deterioration of the intricate wood carvings. Just as the original craftsmen had done, the talented mold builders at Reading Rock recreated the design by hand, resulting in a dazzling reproduction.

## The results

Utilizing this innovative material in the design phase ensured an extraordinary outcome for the project. Selecting RockCast Lightweight provided the design team the ability to recognize their vision of authenticity while increasing durability of the entrance. All of this was achieved without the costly structural support typically associated with this type of stone construction.



“The craftsmanship involved made it possible to perfectly replicate the intricate woodwork from the original entryway but with a more durable material. Also, because it's lightweight, there was no need for the addition of costly structural steel.”

Adam McEachern, Project Manager



## QUICK PROJECT FACTS

Project Location	Tifton, Georgia
Project Goal	Replication of original design
Product Used	RockCast Lightweight
Project Owner	Abraham Baldwin Agricultural College
Architect	McCall Architecture
General Contractor	C E Garbutt Construction Co (Dublin, GA)
Installer	Mid-South Interiors and Exteriors

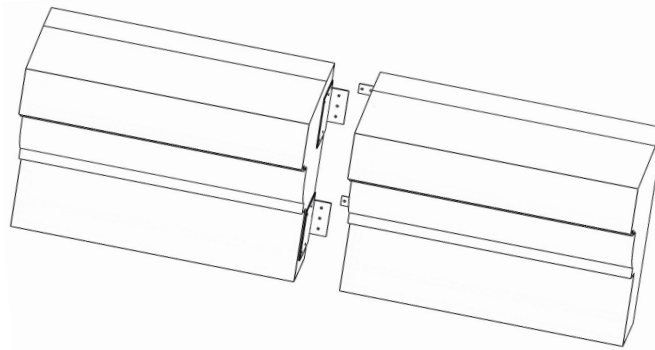

## Your challenge. Our solution.

Since 1947, Reading Rock has had a passion for manufacturing quality masonry products and is currently one of the country's largest cast stone producers. RockCast is a ground-breaking cast stone masonry product offering great versatility in application for use with exterior or interior masonry walls, as a veneer, or as architectural features, trim, or facing for buildings. With a classic look and texture, RockCast offers the structural integrity of natural limestone, sandstone, and granite and can withstand extreme weather conditions.

The RockCast Lightweight Series is a superior-quality, highly durable product that offers all the advantages of regular RockCast but weighs 70% less than traditional cast stone. This means you can have the beauty and durability of stone without requiring structural steel to support it. Use regular, full depth RockCast where it makes sense, use RockCast Lightweight Series where carrying the weight of regular masonry is a challenge and have full confidence that both RockCast products will match and weather the same over time.

This innovative material is simple to install, can utilize a number of trades for installation and reduce the cost of equipment for material placement. Produced with an integral water repellent (IWR), the Lightweight Series requires little maintenance and is easy to clean.

- ◆ Design options
- ◆ Ready, Flex, Plus, Merit & Quick Ship
- ◆ Backed by experience
- ◆ Lifetime Warranty

Learn more. Ask an associate how Reading Rock can help you find a solution with one of our Architectural Stone Solutions. Contact us at 800.482.6466 or online at [www.readingrock.com](http://www.readingrock.com) to request additional information.