

Wood Chipper

PC-2700-PEH



Efficient Hand-Fed Wood Chipper

The Fransgård PC-2700-PEH wood chipper is designed for manual feeding of logs up to Ø27 cm and can be equipped with the patented 360° console system.

Valuable details

Large selection of other machines

Read more at www.fransgard.dk



3-Point Linkage

The robust 3-point linkage ensures safe mounting on the tractor.



Hydraulic Motor

The feed rollers are driven by a robust hydraulic motor.



No-Stress System

The wood chipper is equipped as standard with a No-Stress system, ensuring sufficient rotor speed is always maintained for efficient chipping.



Horizontal Feed

The feed system consists of two horizontally positioned feed rollers, providing a strong construction and optimal grip on the wood. The adjustable feed speed can be infinitely varied to ensure smoother and more efficient operation. *for at opnå mere jævn og tilpasset drift.*



Rotor Locking Bolt

The locking bolt is a safety feature. It is mounted into the side of the rotor to prevent unintended rotation during service or inspection.

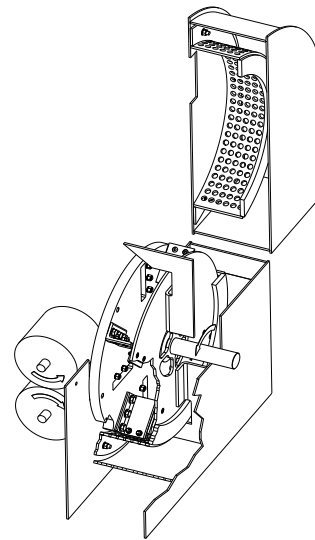

Patented system for high-quality wood chips:

Thanks to the patented 360° console, the PC-3300-PEC pellet wood chipper produces uniform **PC-FLIS®** without splinters or clumps. **PC-FLIS®** stands for high-quality wood chips with a homogeneous structure and no oversized particles.

Only chips produced with a PC pellet wood chipper may be referred to as PC-FLIS®.

PC-FLIS® is ideal for heating systems, as splinter- and clump-free chips reduce the risk of blockages in auger systems. This provides a reliable, cost-effective and environmentally friendly alternative to wood pellets.

The combination of knife settings and console size allows precise control of the chip fraction. The pellet wood chipper can therefore be configured for different applications – for example PC-FLIS® as high-quality animal bedding without sharp residues. The flexible setup provides a wide range of applications.

Technical Data

Technical Data	PC-2700-PEH
Type	Pellet wood chipper with 360° console
Wood diameter (max.)	Ø27 cm
PTO speed	540 / 1,000 rpm
Power requirement at 540 rpm	Max. 60 kW / 80 hp
Power requirement at 1,000 rpm	Max. 112 kW / 150 hp
Main shaft spline	1 3/4" x Z6
Weight	1,500 kg
Mounting	3-point linkage on tractor
Hydraulics	From tractor
Number of feed rollers	2
Feed roller torque	Up to 1,096 Nm
Rotor weight (total)	Approx. 380 kg
Capacity *	30 m³ per hour
Crane mounting option	No
No-Stress system	Yes, standard

* Capacity depends on knife settings, available horsepower, wood condition and rotor speed.

Meets the latest, strict safety requirements for wood chippers

Made in Denmark

A strong combination of modern production equipment — including laser cutting — and skilled craftsmanship ensures that our products meet the highest standards for durable and reliable machinery. Since all machines are developed, produced and assembled at our own factory in Denmark, we can quickly adapt production to customer requirements.

This provides a high level of flexibility that our customers have appreciated for many years. With in-house production, we maintain full control over each order, ensuring that the correct machine is delivered on time.

That's Danish efficiency and quality at its best.

Dealer:

Manufacturer:

Fransgård Maskinfabrik A/S
Fredbjergvej 132 · dk-9640 Farsø
T: +45 98 63 21 22
www.fransgard.dk

 **Fransgård**