

WEST COAST STAIR CO.

Premium Floating Stair Solutions
Delivered by West Coast Stair Co.

Prestige Metal
GARDE-CORPS | RAILINGS



The New York

■ Features

- *Unique tread attached at beam with no visible screws*
- *7-1/2" beam width*
- *Available in the following colors*
 - ACV, BU, BW, CM, CU, GU, MU, NT, NU
- *Maximum tread width: 54"*
- *Maximum treads allowed: 16 (with run between 9" and 11")*



The New York

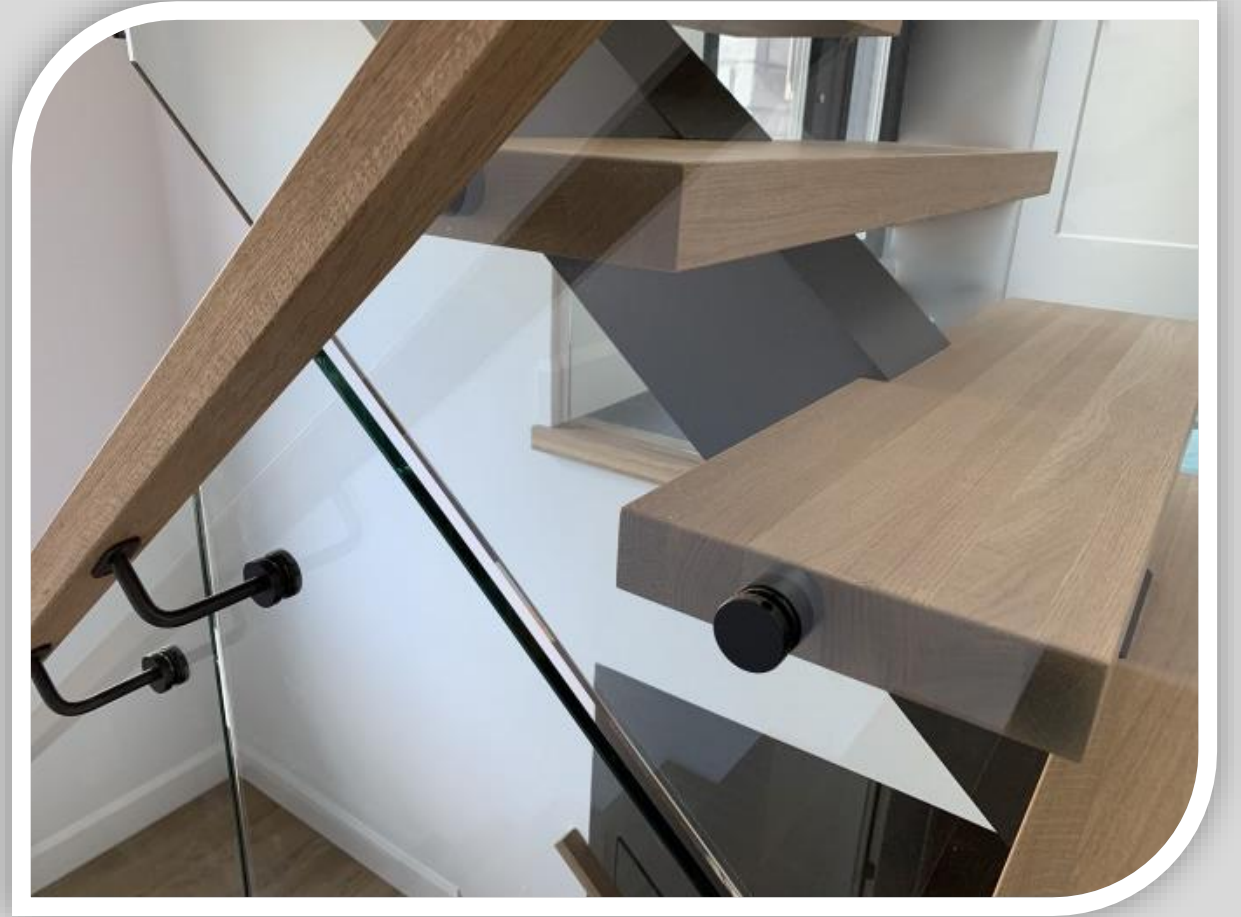
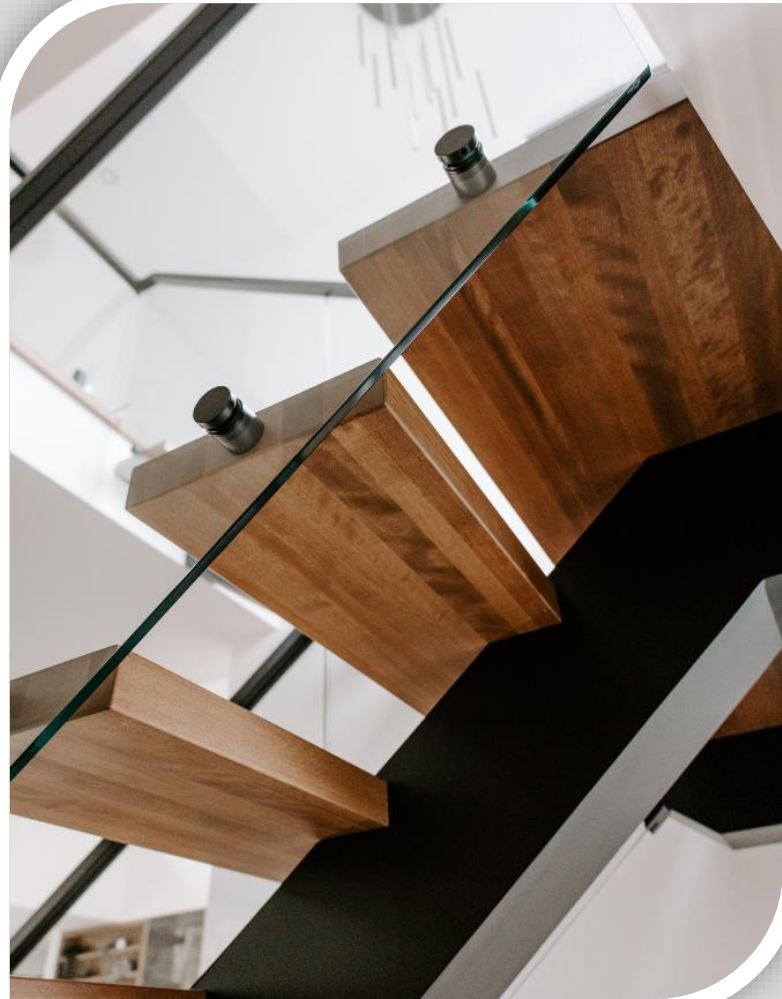

The New York

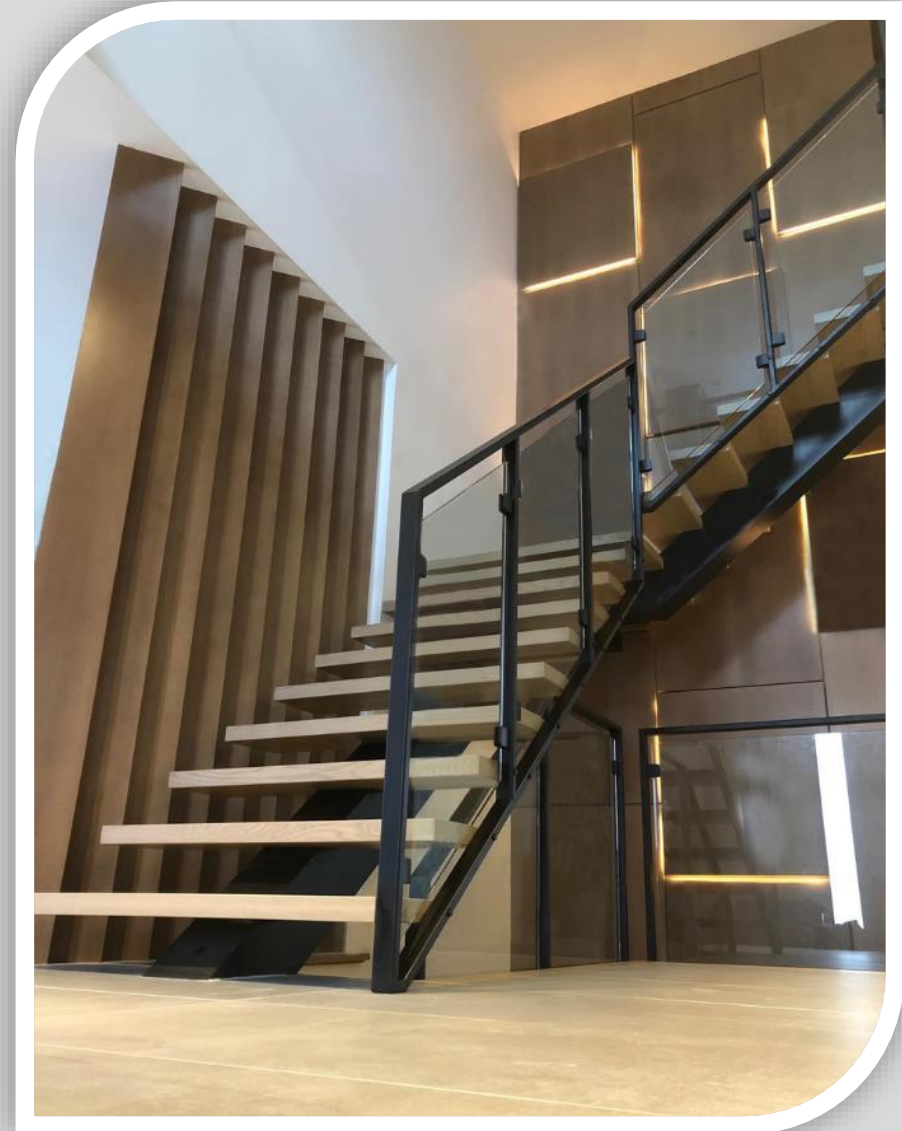
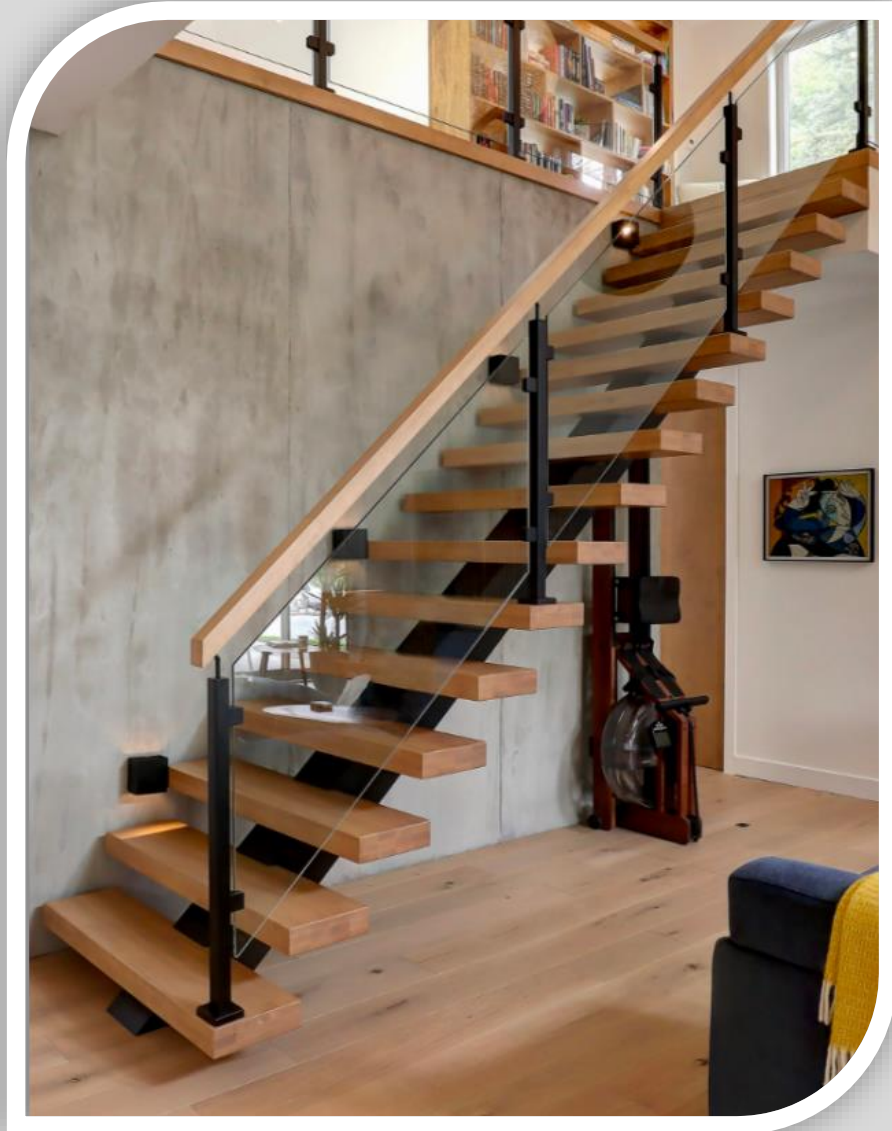

The New York – Stringer Detail

TOP OF THE STAIRS

Option of an upper fixed plate of 1 5/8"

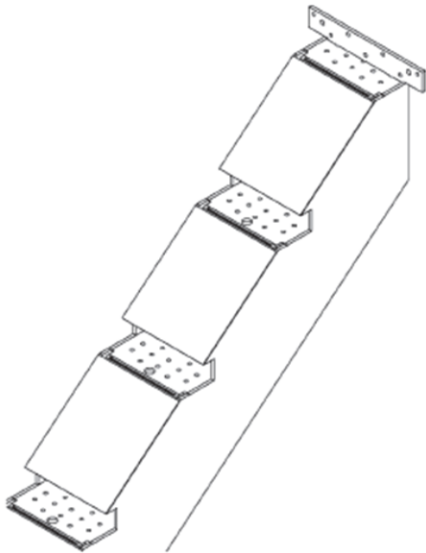

Option of an upper fixed plate of 6"

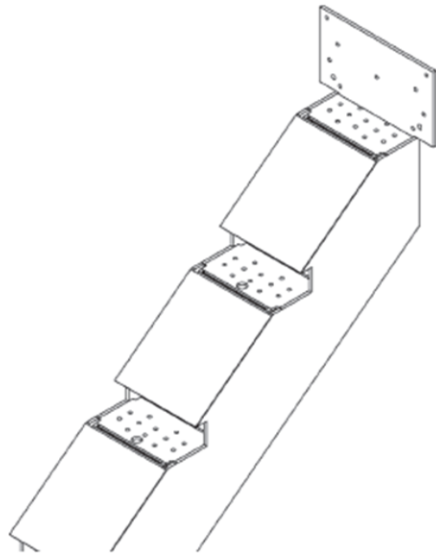

BOTTOM OF THE STAIRS

Option Plat
Interior fixing plate

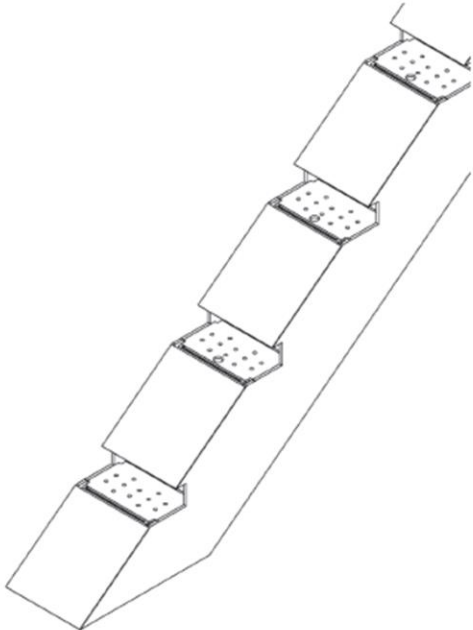

Option Angle
Fixed with an angle mounting plate

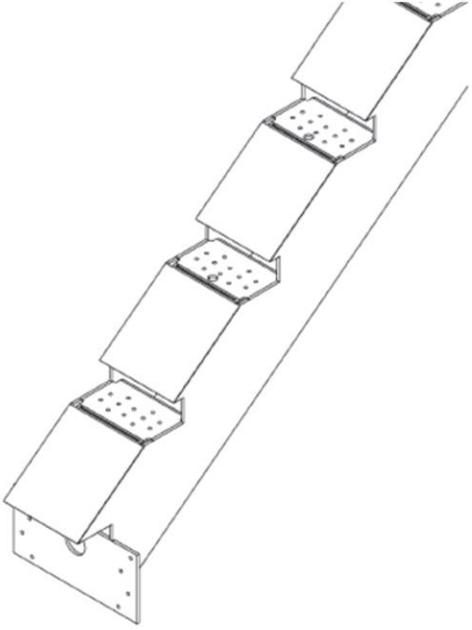

The Paris

■ Features

- *5-1/2" beam width*
- *Treads sit on metal plate with visible screw attachments*
- *Available in the following colors*
 - ACV, BU, BW, CM, CU, GU, MU, NT, NU
- *Maximum tread width: 54"*
- *Maximum treads allowed: 17 (with run between 9" and 10")*

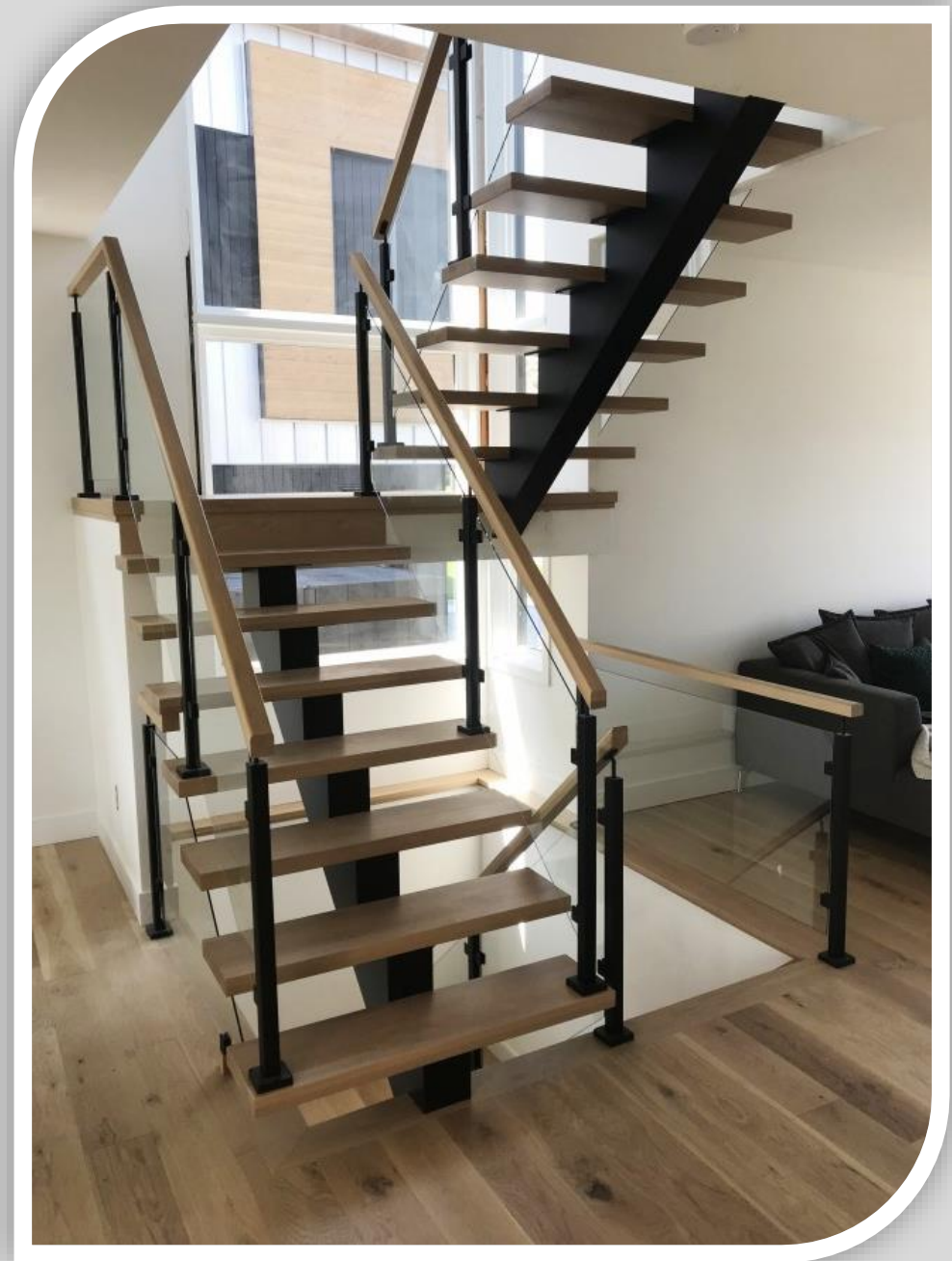

The Paris

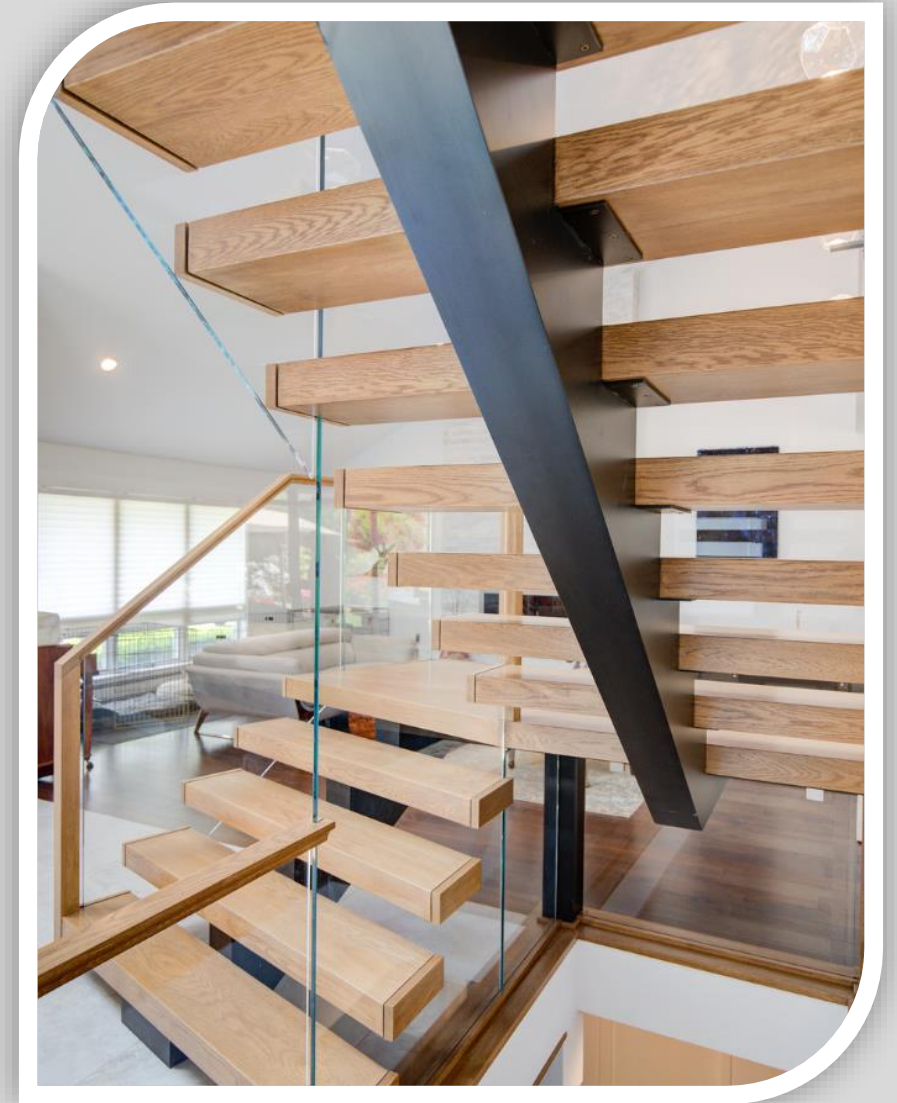
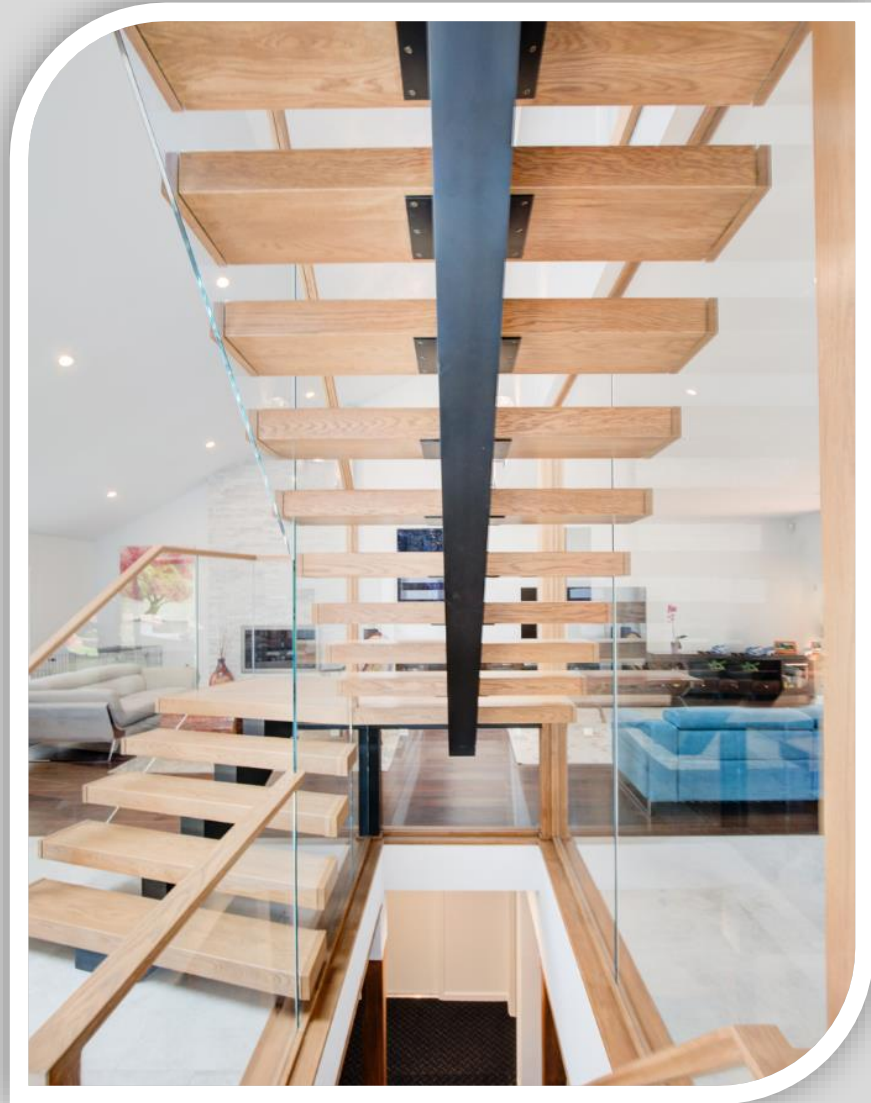

The Paris

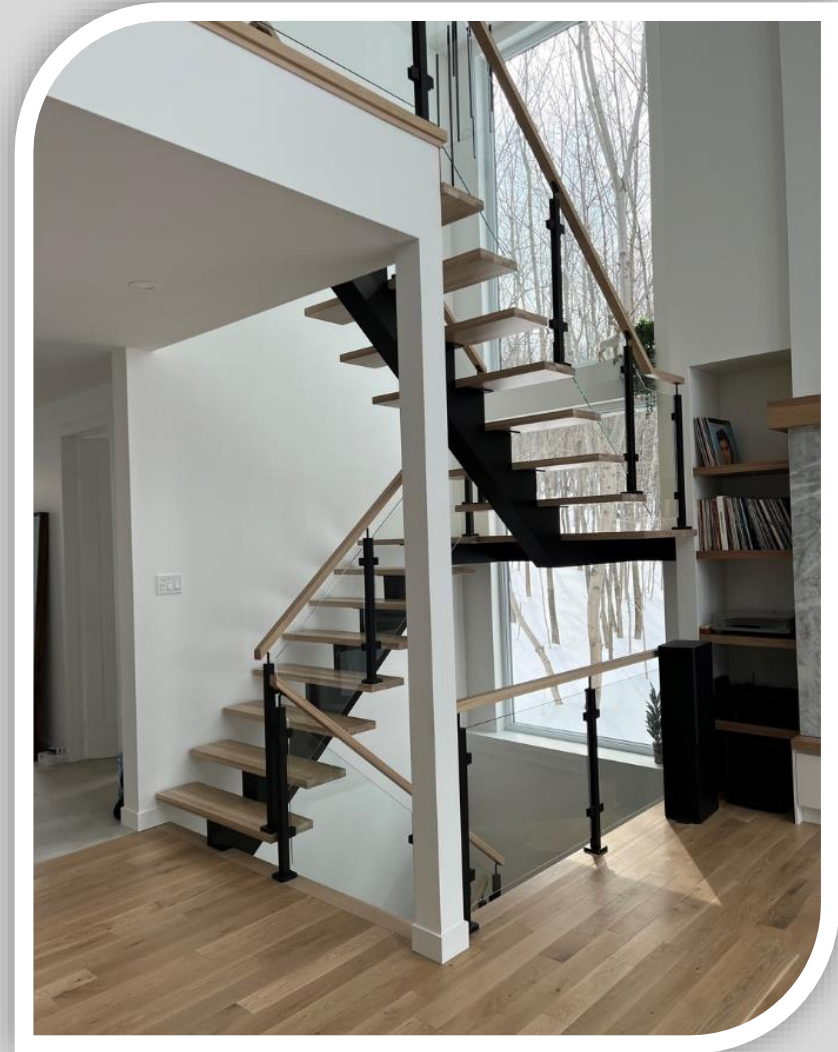
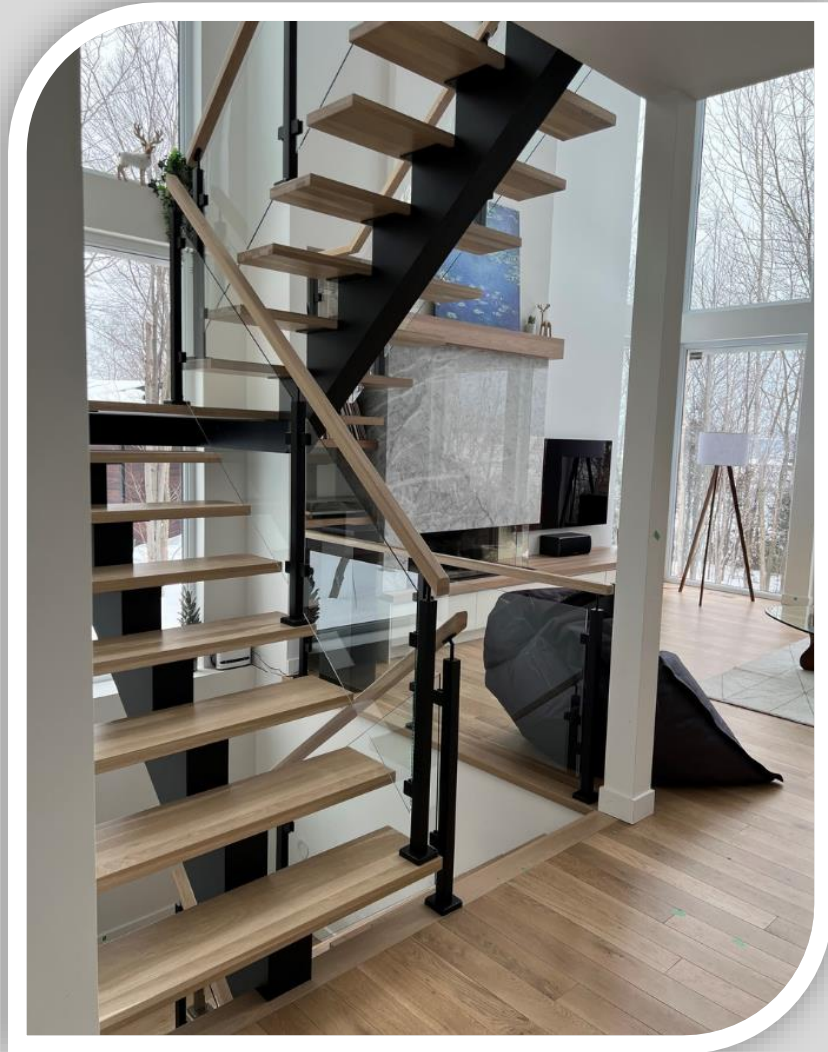

The Paris- Stringer Detail

TOP OF THE STAIRS

Option of an upper fixed plate of 1 5/8"

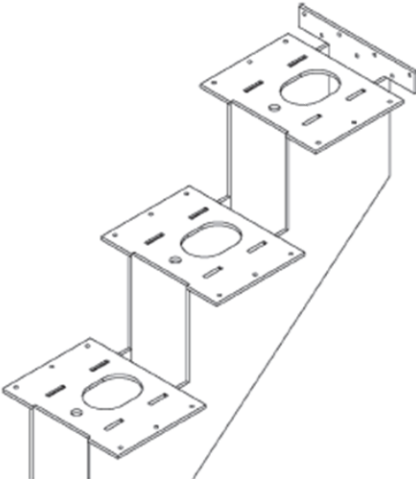

Option of an upper fixed plate of 6"

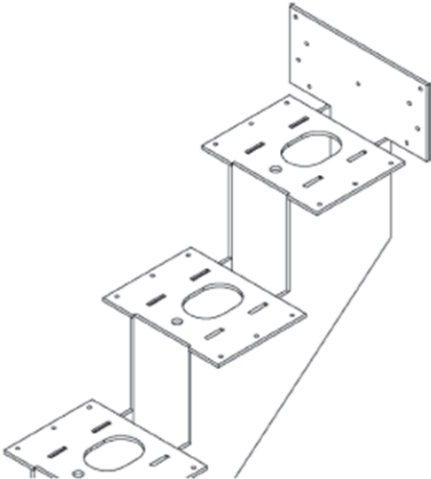

BOTTOM OF THE STAIRS

Option Plat
Fixed with a flat plate

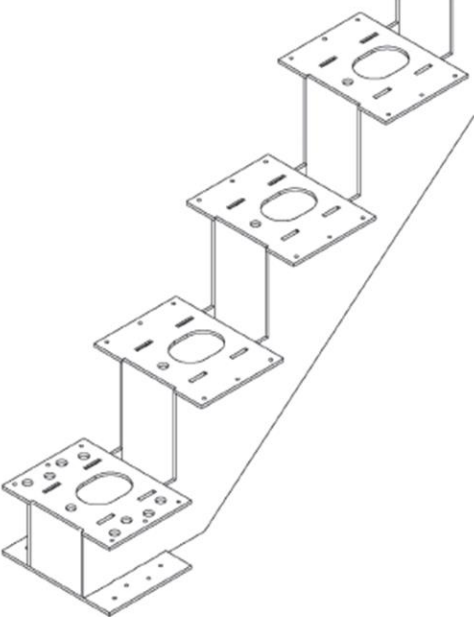

Option Angle
Fixed with an angle mounting plate

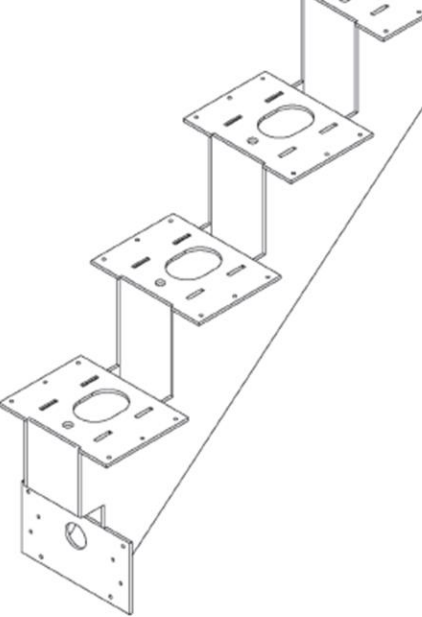

The Oslo

■ Features

- *Double stringer, ½" Steel Plate*
- *12" stringer height*
- *Treads sit on metal plate with visible screw attachments*
- *Available in the following colors*
 - ACV, BU, BW, CM, CU, GU, MU, NT, NU
- *Maximum tread width: 54"*
- *Maximum treads allowed: 13 (with run between 9" and 10")*



The Oslo

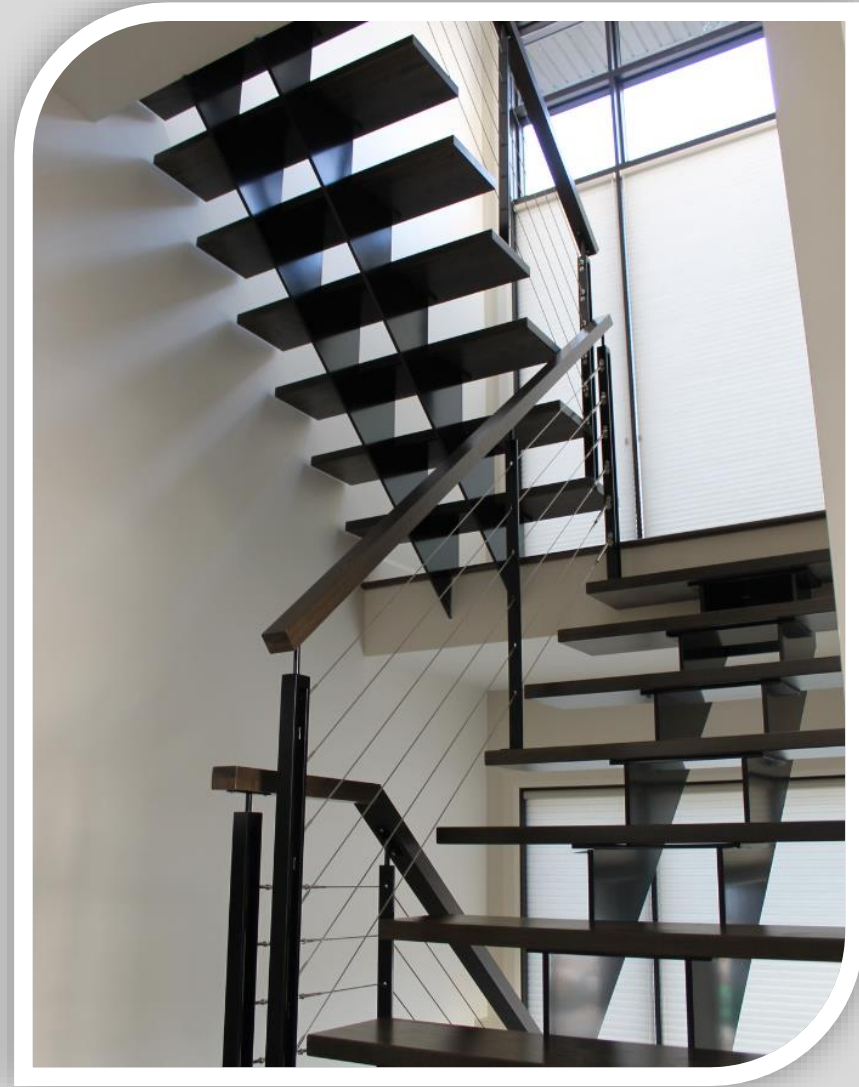

The Oslo – Stringer Detail

TOP OF THE STAIRS

Option of an upper fixed plate of 1 5/8"

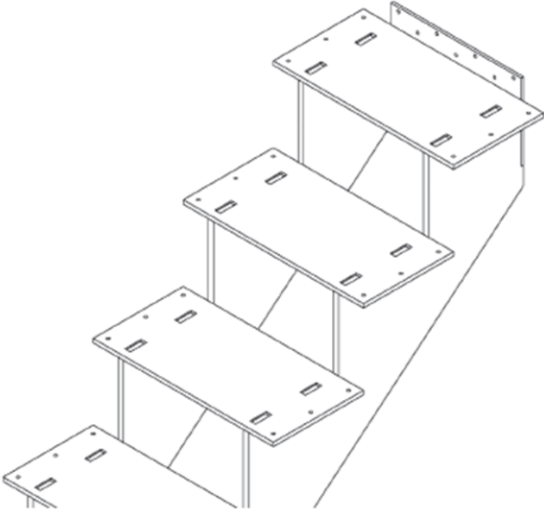

Option of an upper fixed plate of 6"

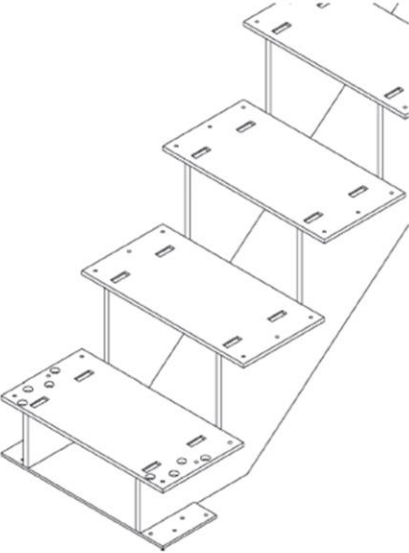
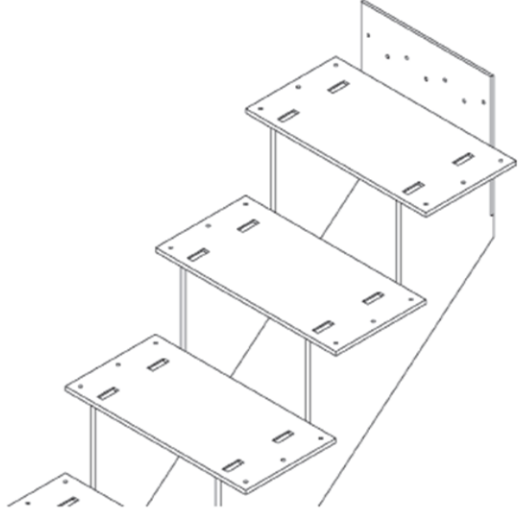

BOTTOM OF THE STAIRS

Option Plat
Fixed with a flat plate

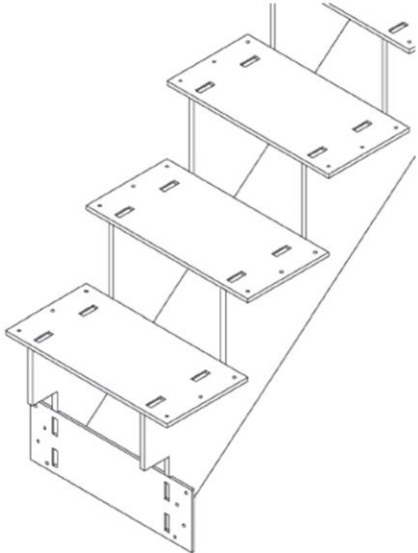

Option Angle
Fixed with an angle mounting plate

The Tokyo

■ Features

- *6"x6" Steel Tube Stringer*
- *Treads sit on metal pedestal with visible screw attachments*
- *Available in the following colors*
 - ACV, BU, BW, CM, CU, GU, MU, NT, NU
- *Maximum tread width: 48"*
- *Maximum treads allowed: 14 (with run between 9" and 10")*

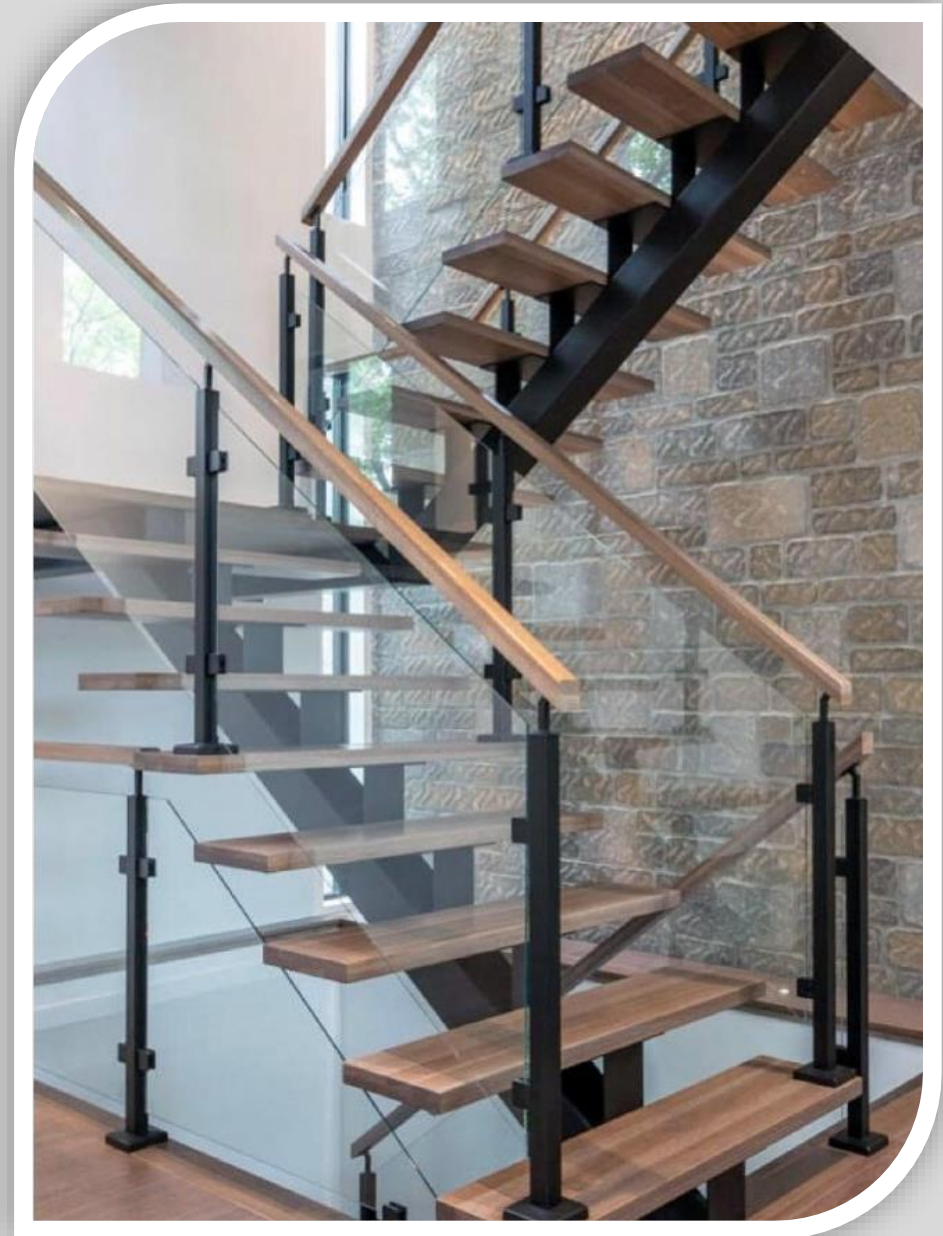

The Tokyo

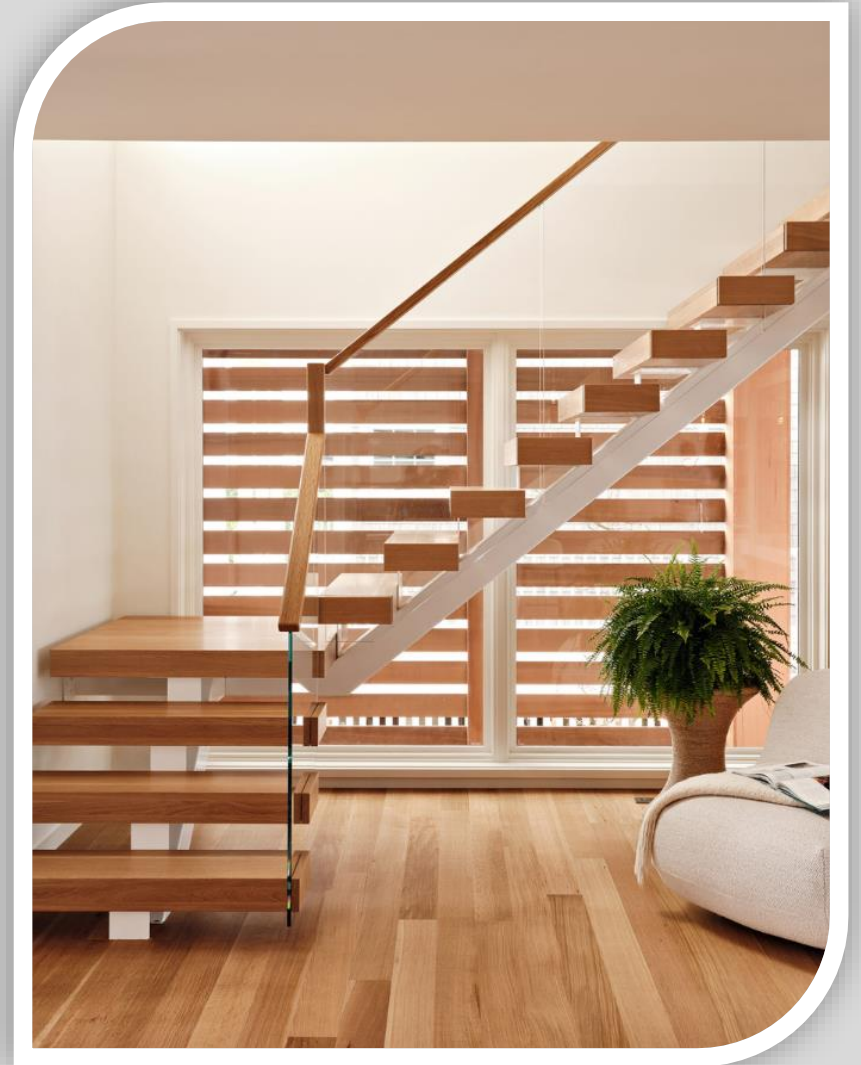
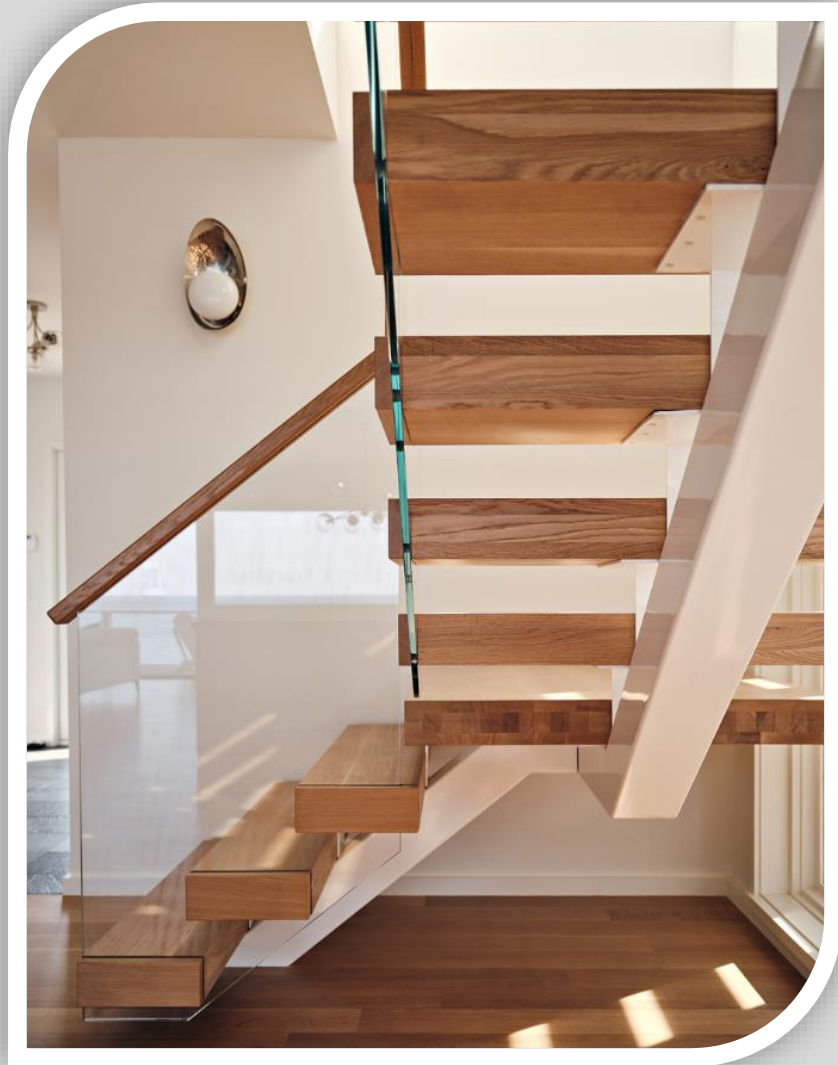

The Tokyo

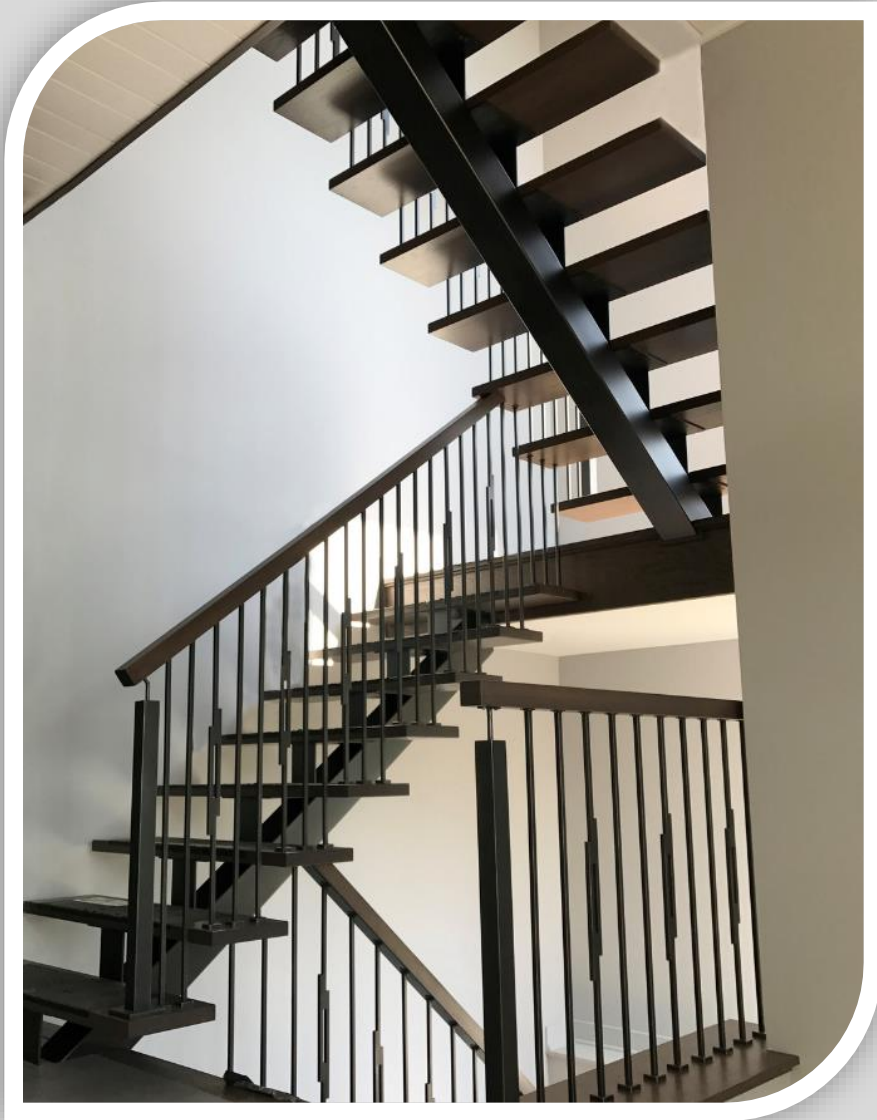

The Tokyo – Stringer Detail

TOP OF THE STAIRS

Option of an upper fixed plate of 1 5/8"

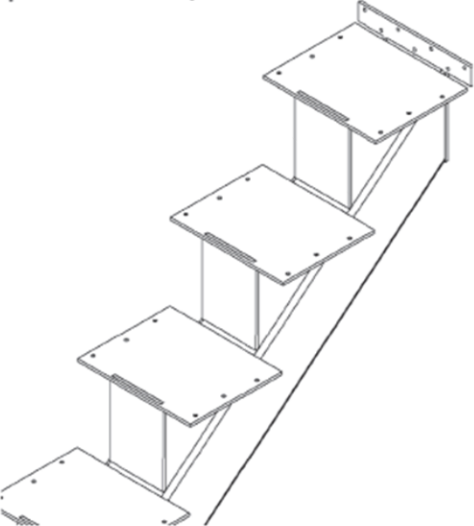

Option of an upper fixed plate of 6"



BOTTOM OF THE STAIRS

Option Plat
Fixed with a flat plate

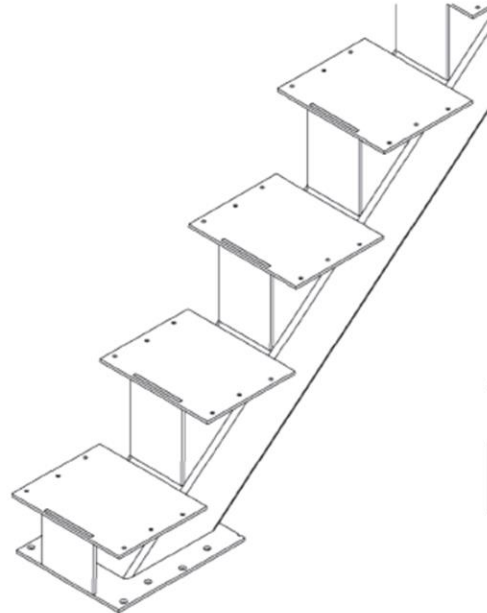

Option Angle
Fixed with an angle mounting plate

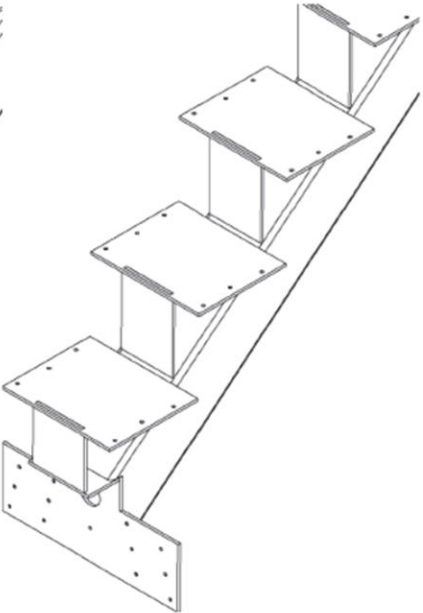

The San Diego

■ Features

- *Dual 12"x1" Steel Stringers with channel for glass balustrade.*
- *Option for "hidden stringer" at wall side.*
- *Option for tread attachment plate recessed in treads*
- *Available in the following colors*
 - ACV, BU, BW, CM, CU, GU, MU, NT, NU
- *Maximum tread width: 54"*
- *Maximum treads allowed: 18 (with run between 9" and 11")*

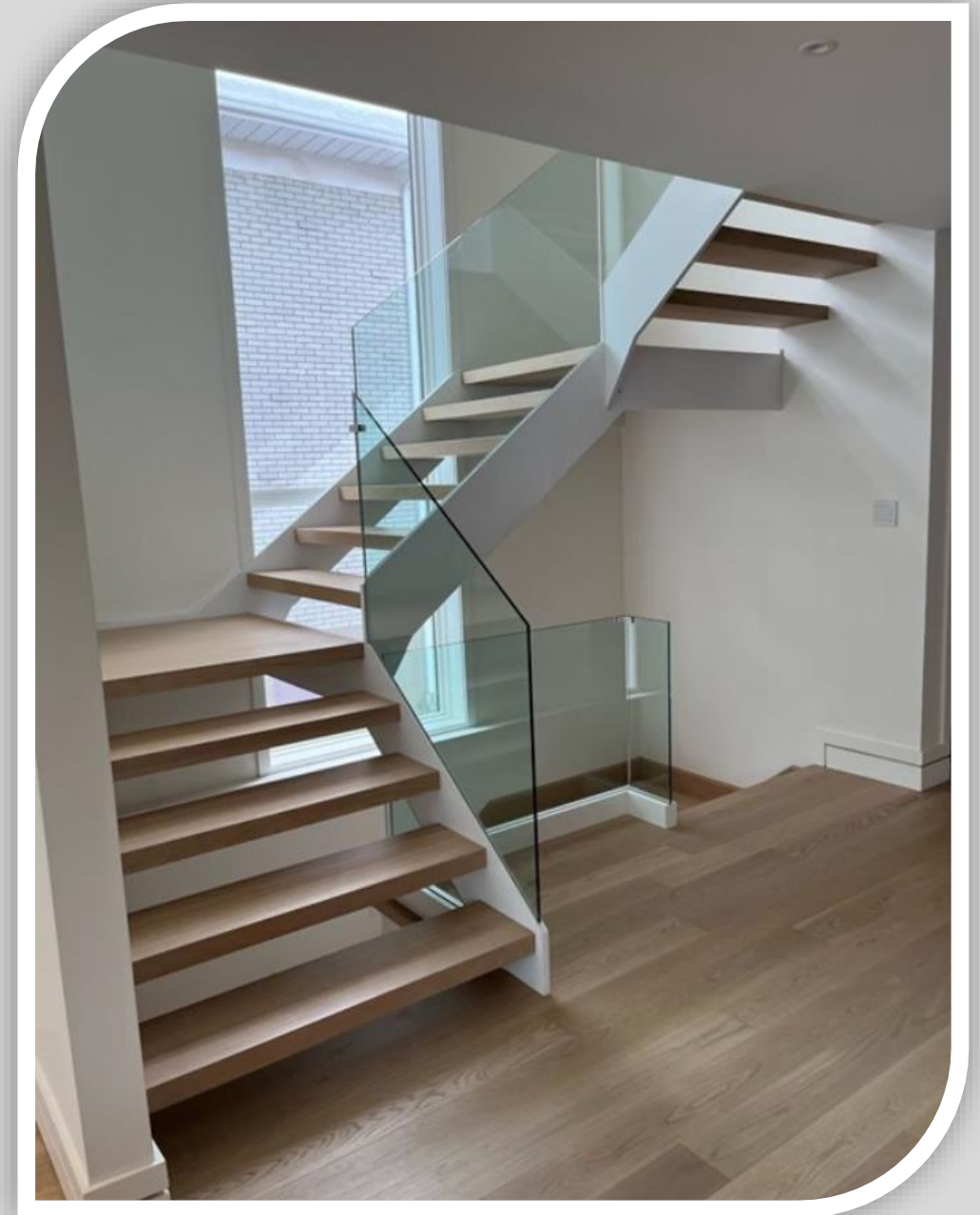

The San Diego

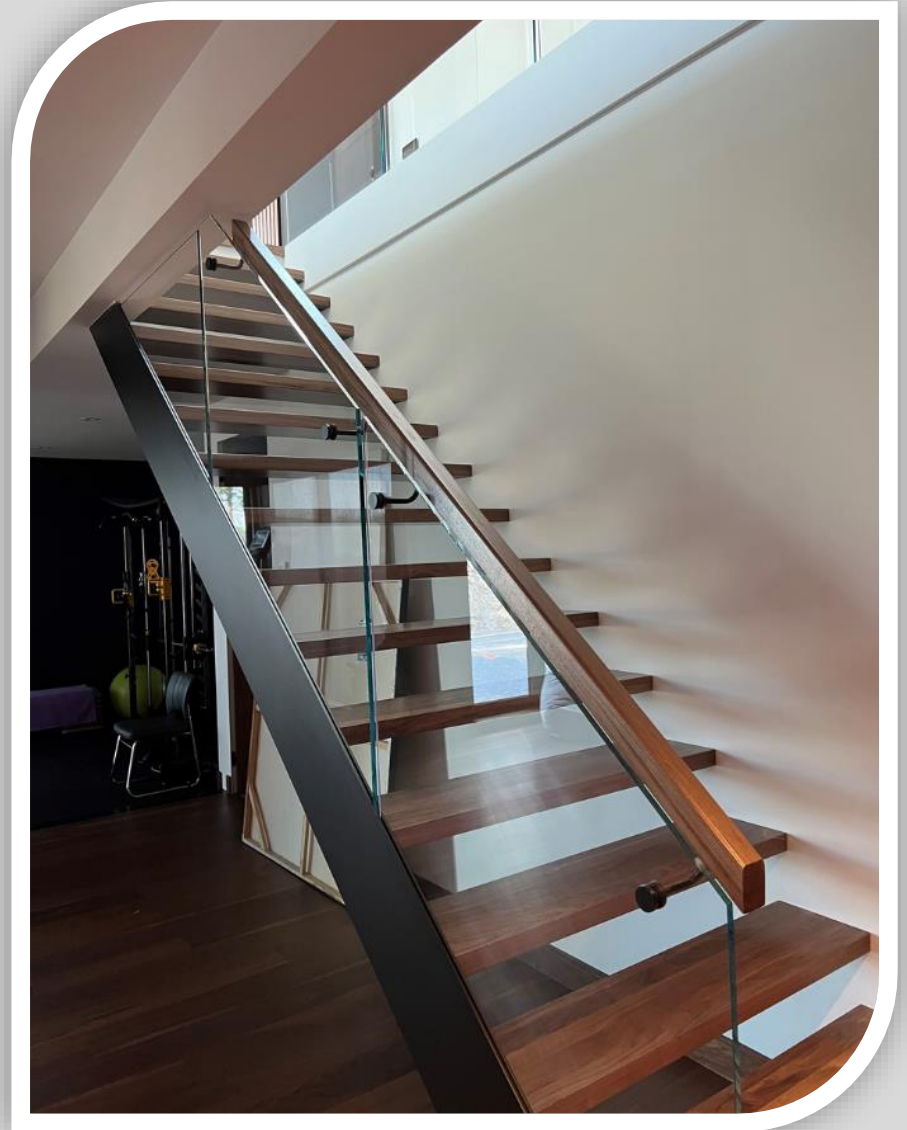
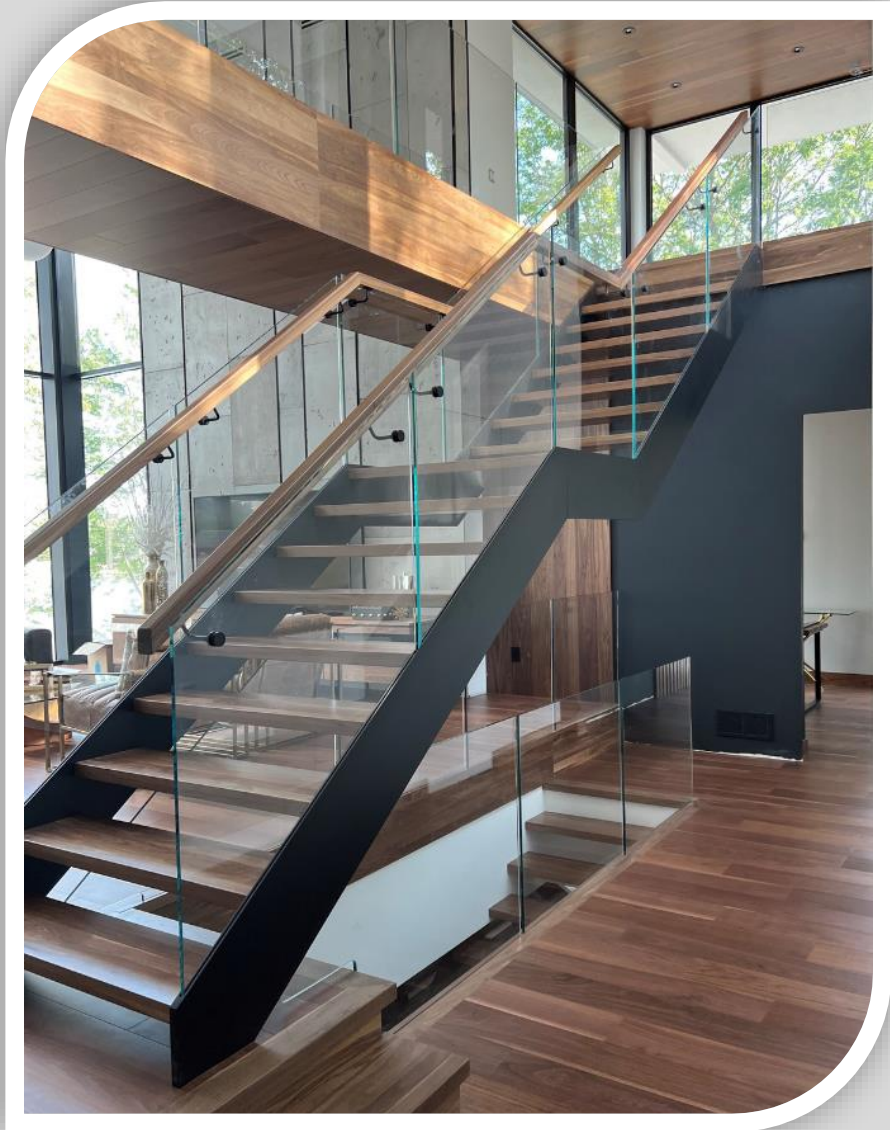

The San Diego

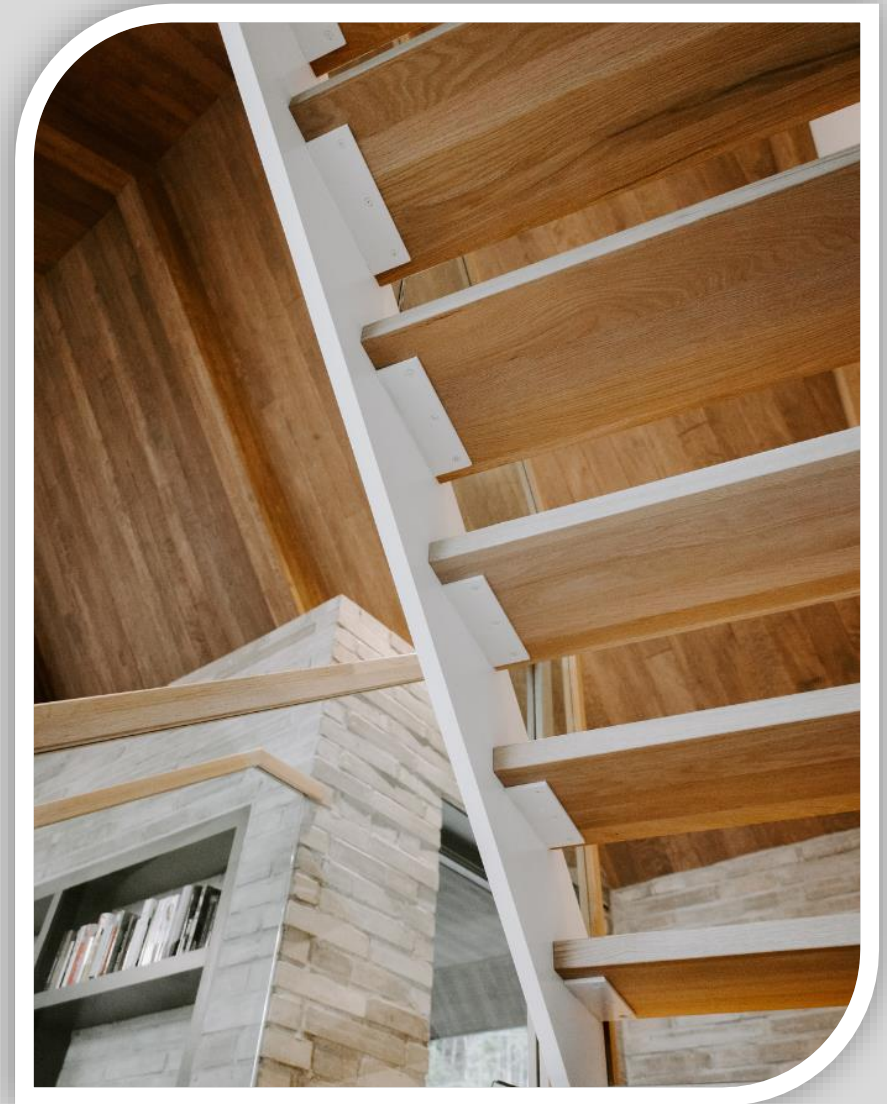
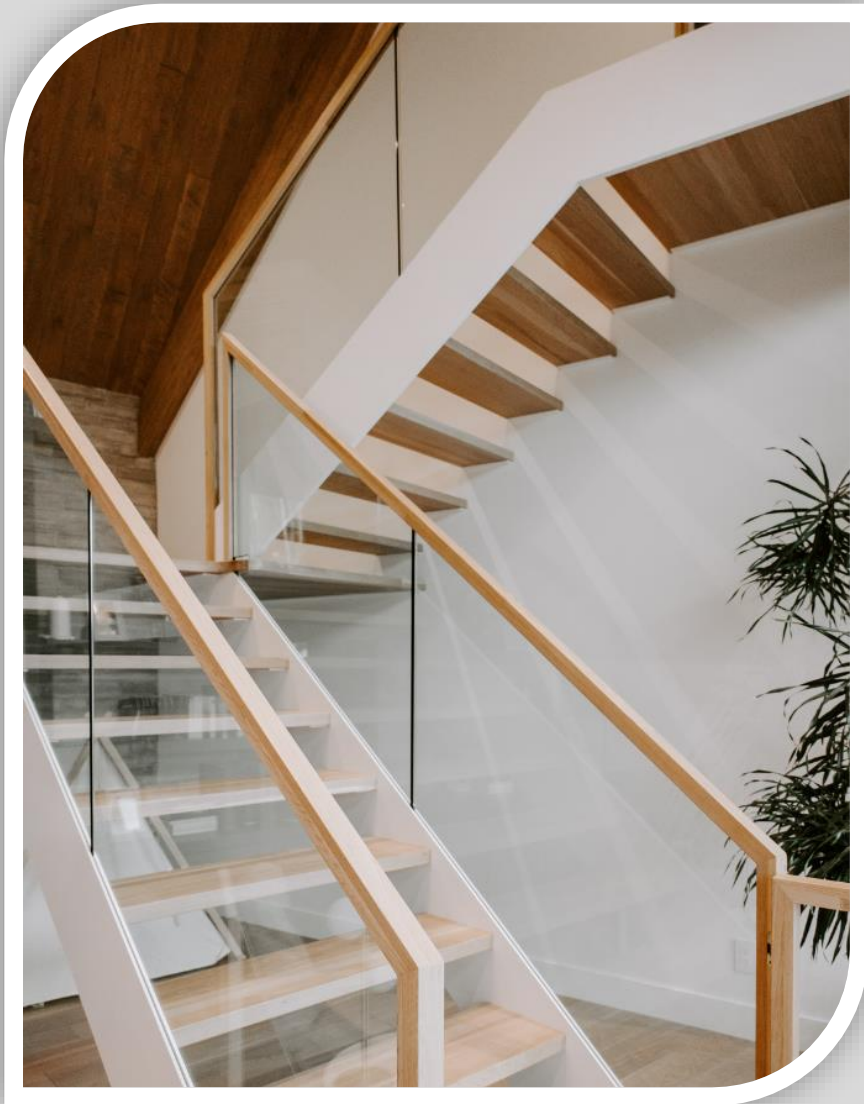

The San Diego – Stringer Detail

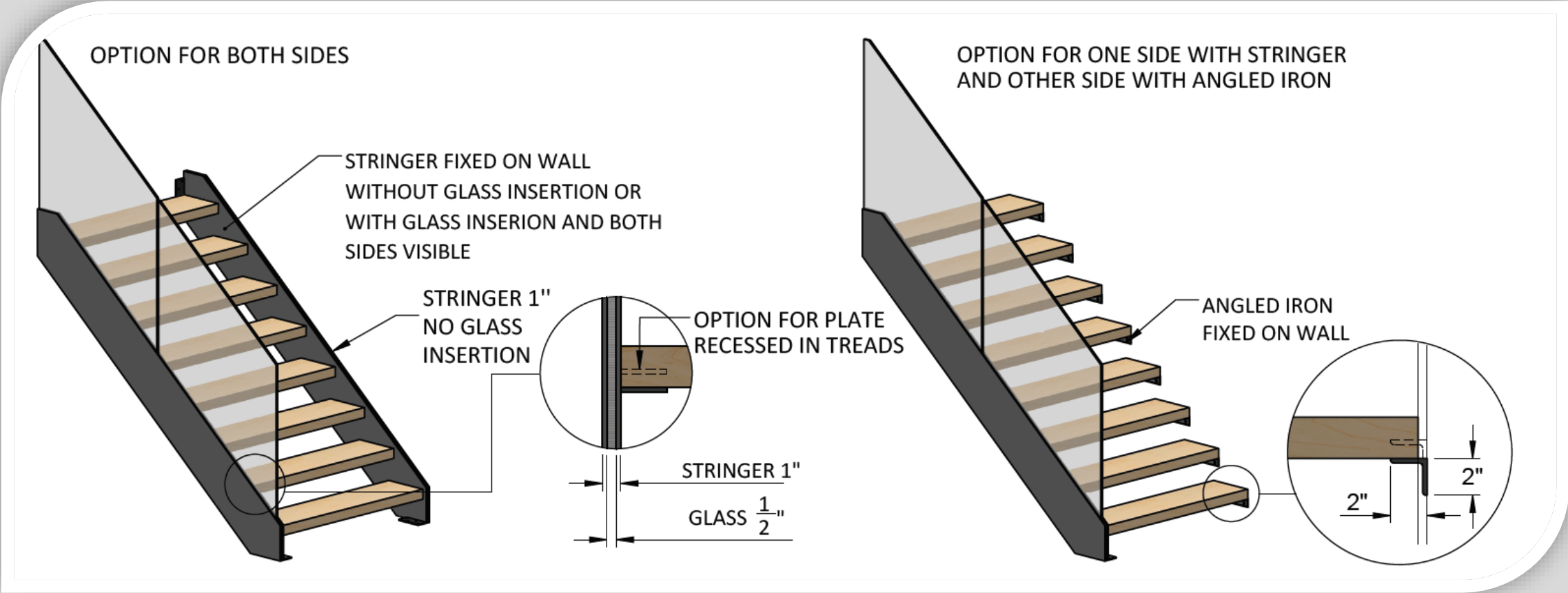

The Chicago

■ Features

- *Hidden Stringer in wall to create a truly floating stair experience*
- *Available in the following colors*
 - Steel Stringer with Primer
- *Maximum tread width: 54"*
- *Maximum treads allowed: 18 (with run between 9" and 11")*

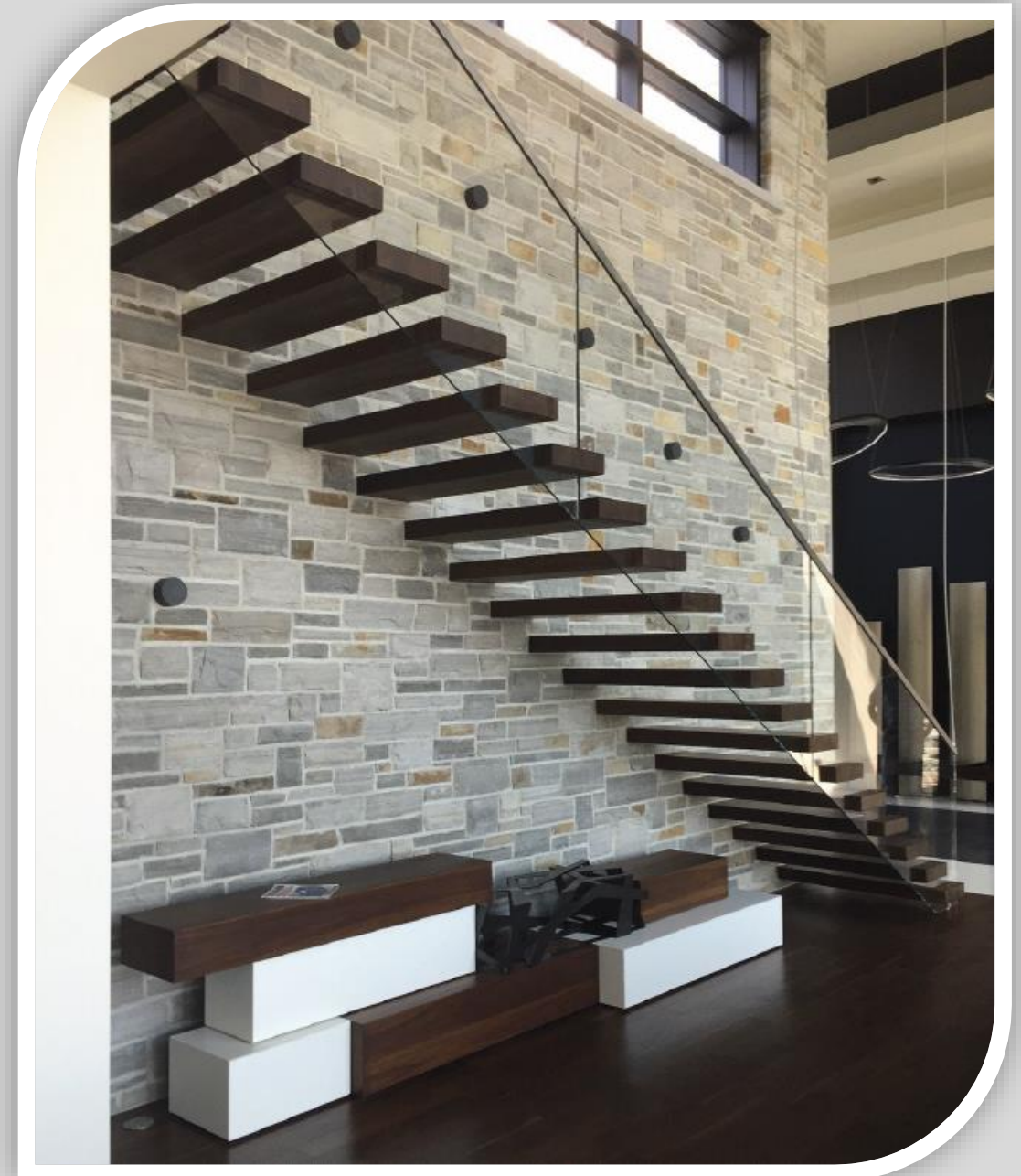

The Chicago

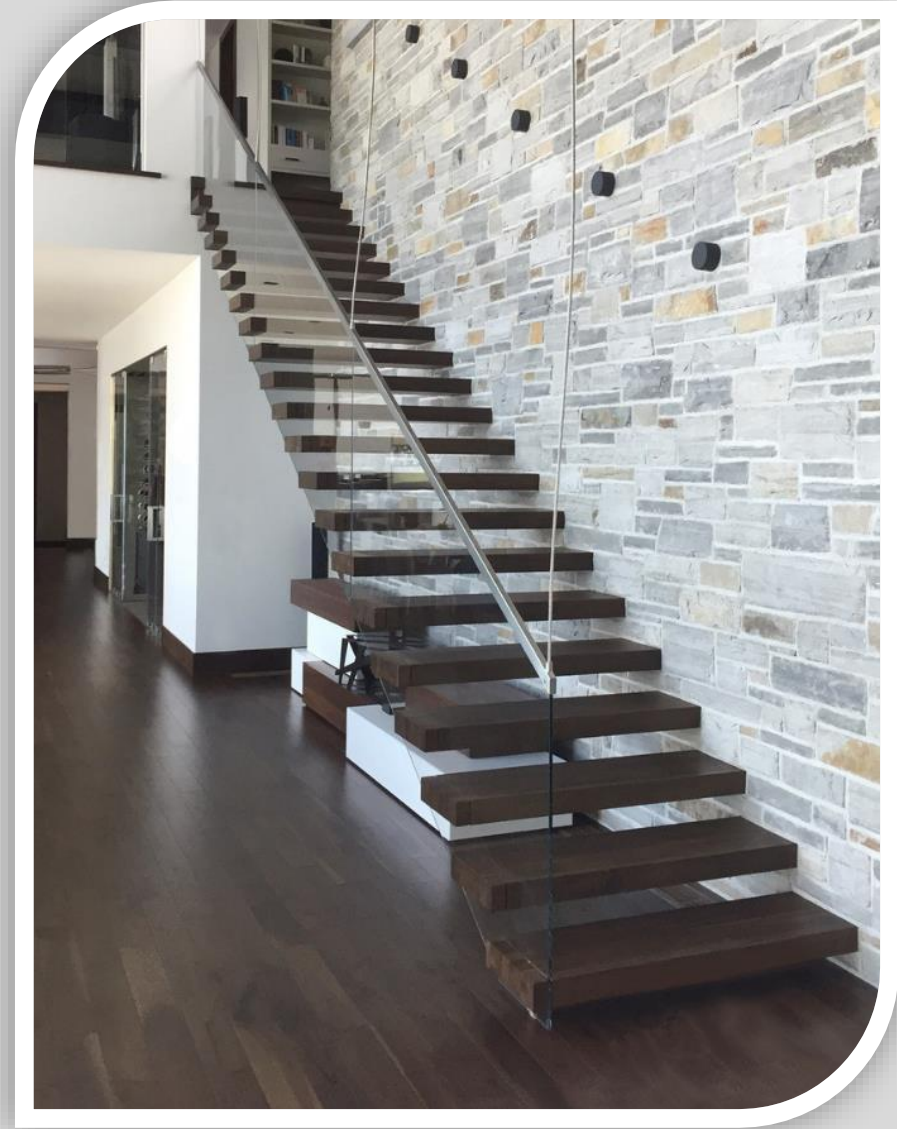
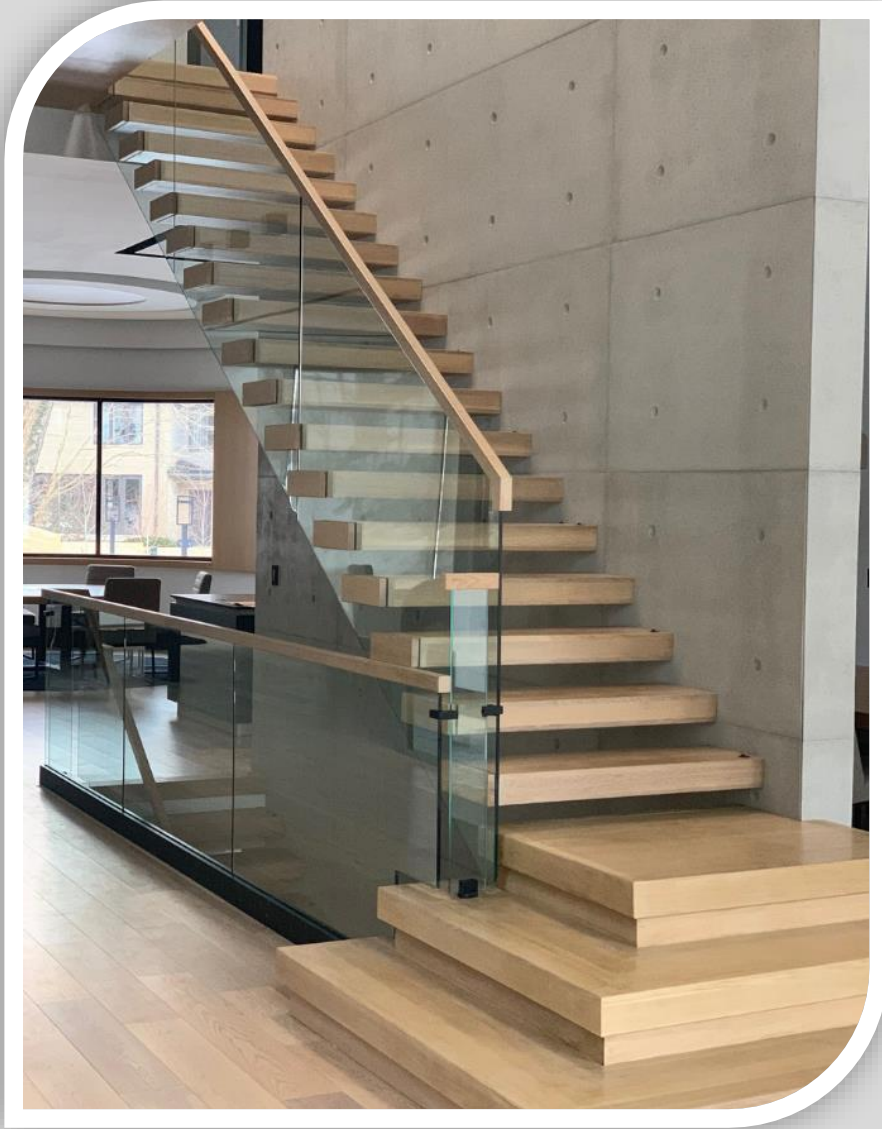

The Chicago – Stringer Detail

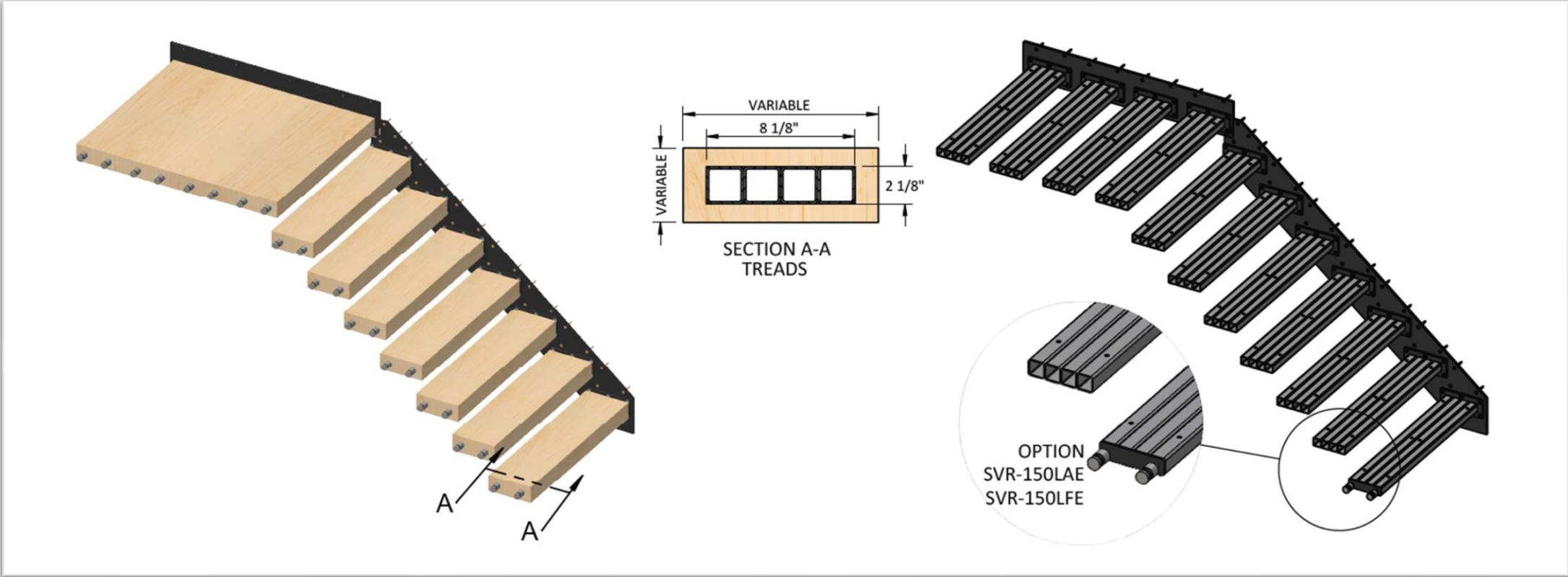

The Seattle

- Features
 - *7-1/4" Wide steel stringer*
 - *Hidden tread attachment with no visible screws at treads.*
 - *Available in the following colors*
 - ACV, BU, BW, CM, CU, GU, MU, NT, NU
 - *Maximum tread width: 54"*
 - *Maximum treads allowed: 15 (with run between 9" and 10")*

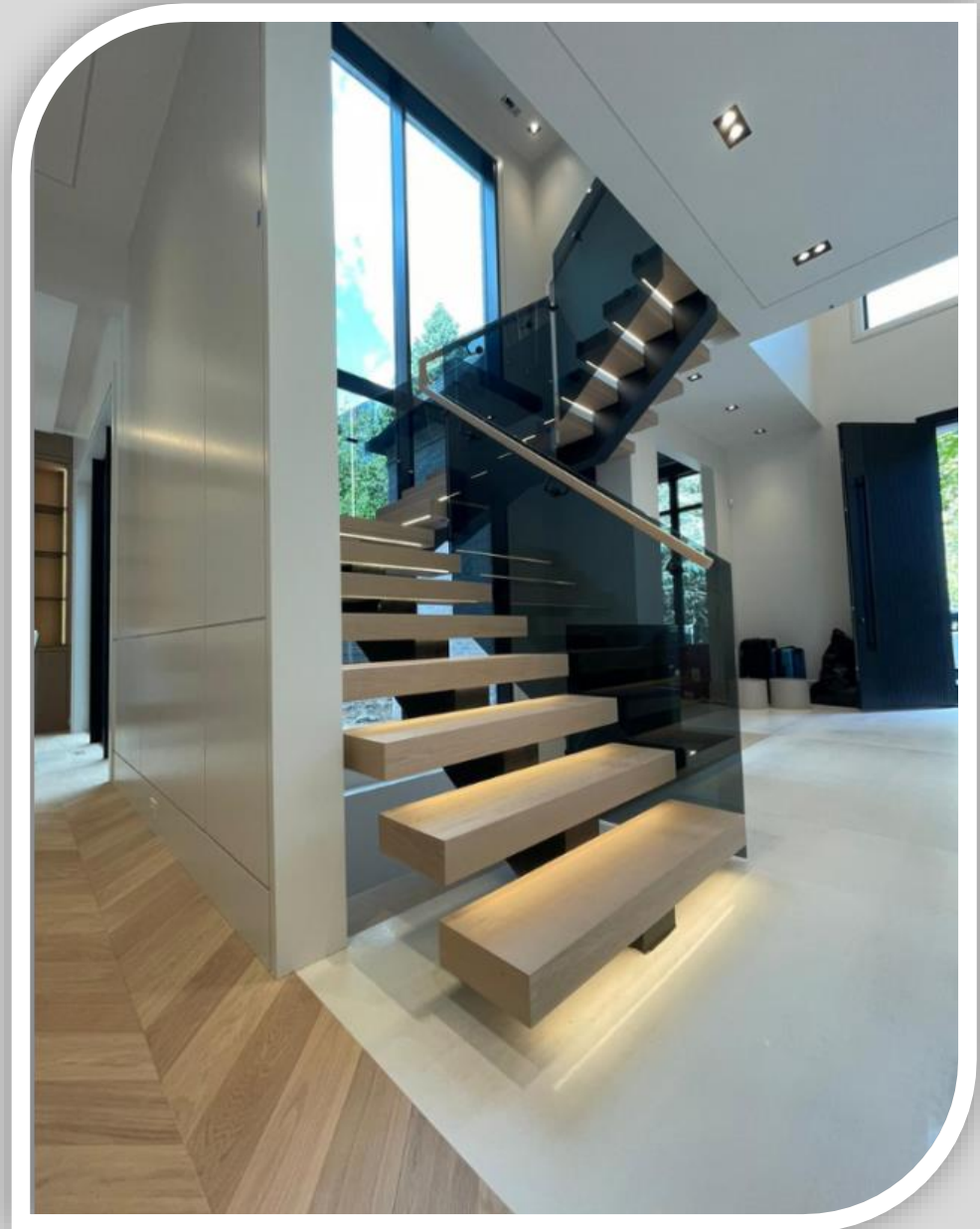

The Seattle

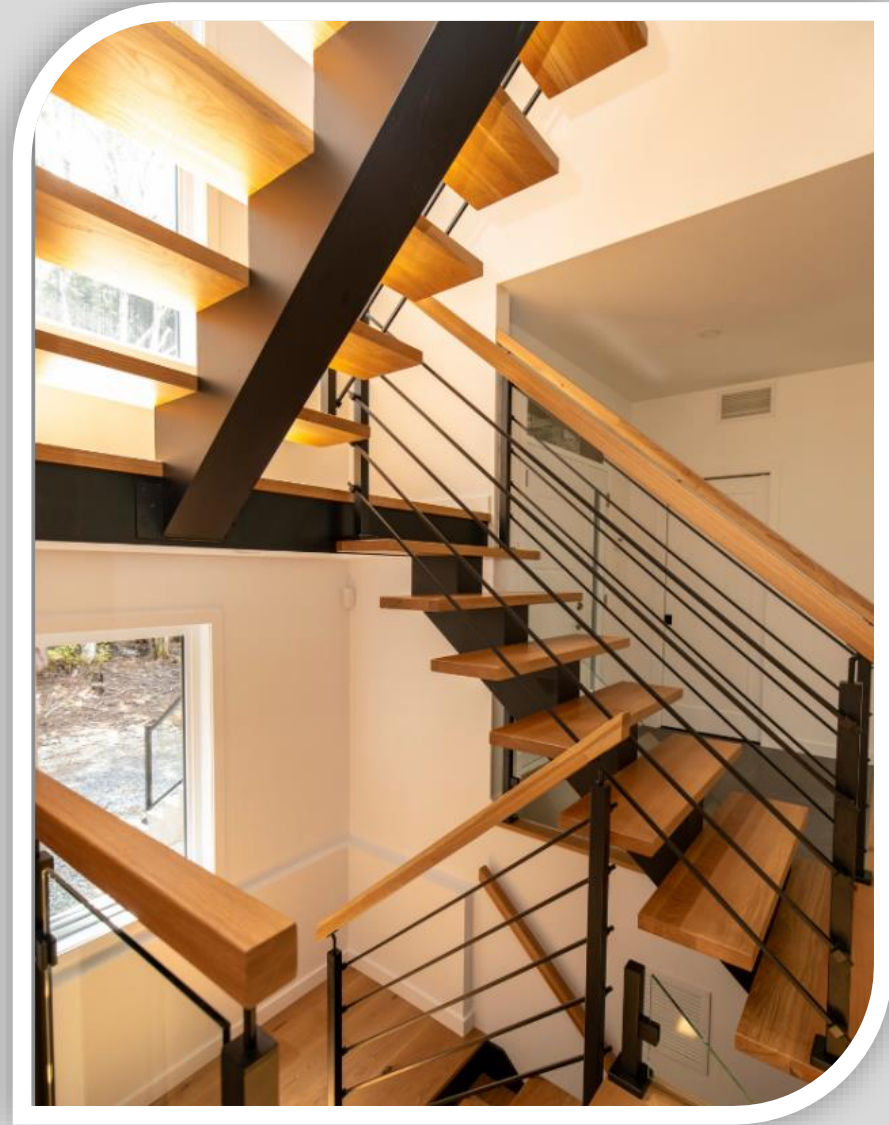
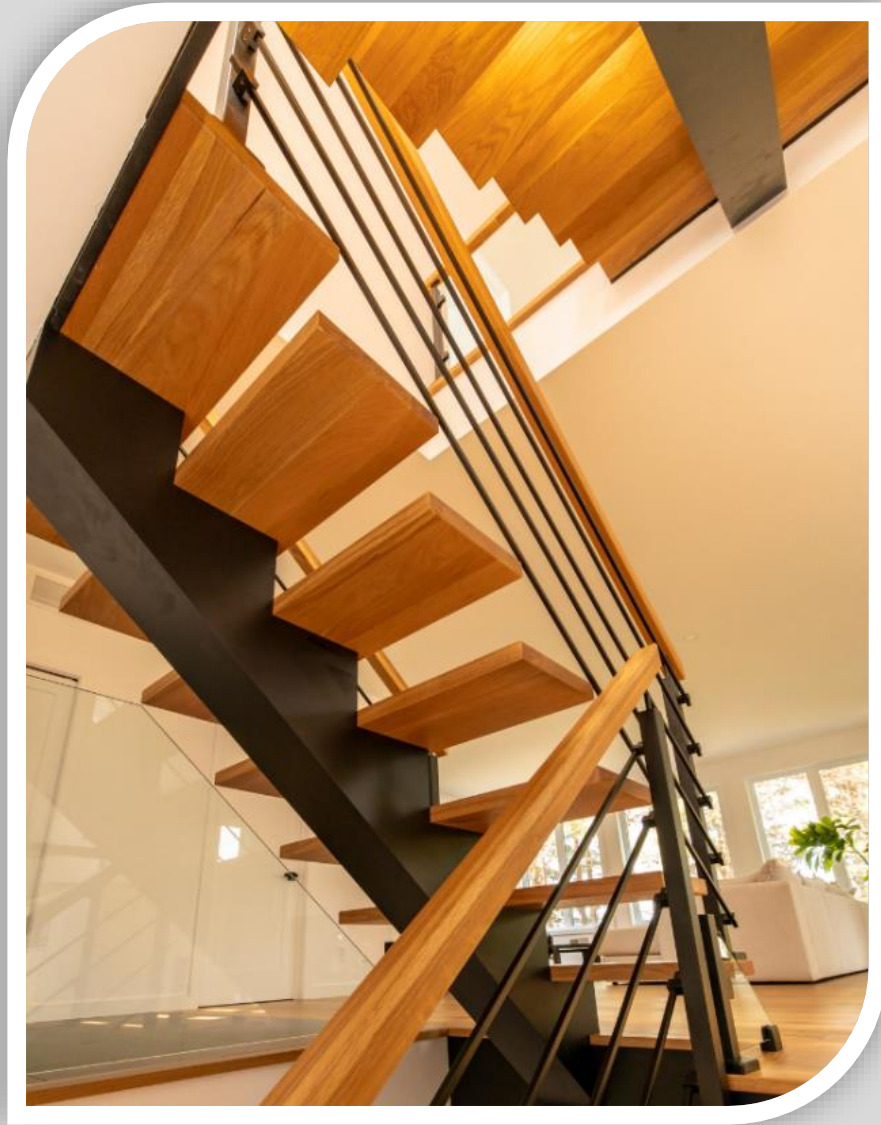

The Seattle

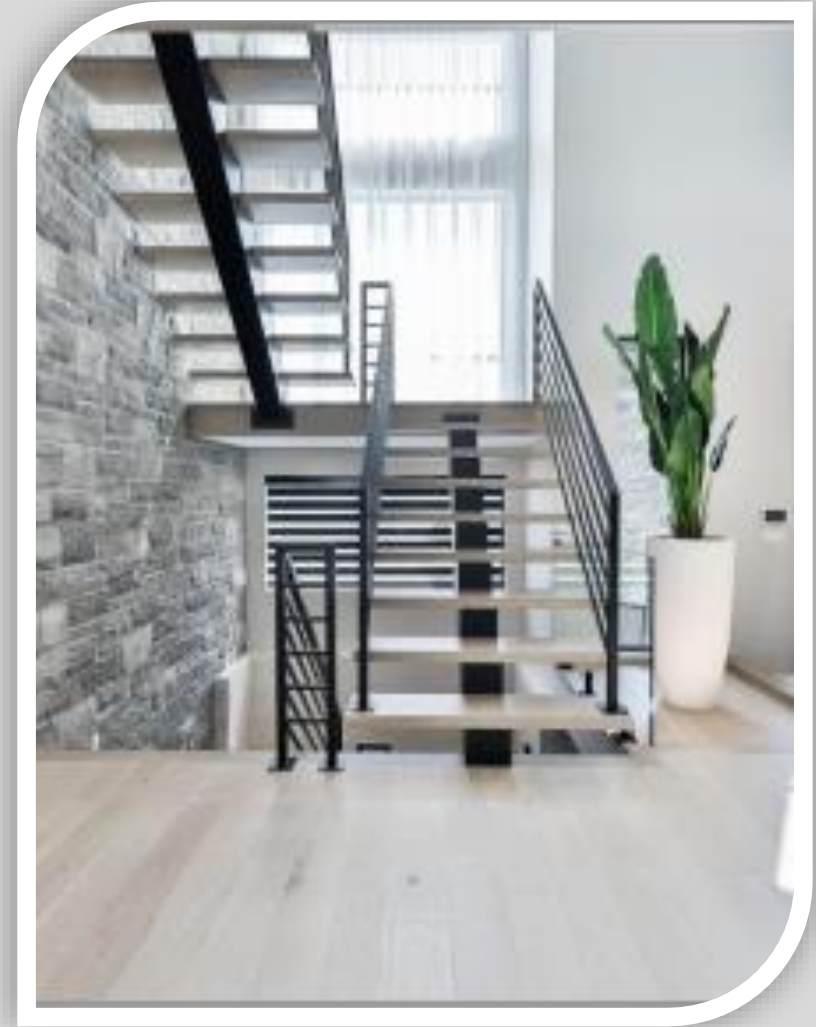
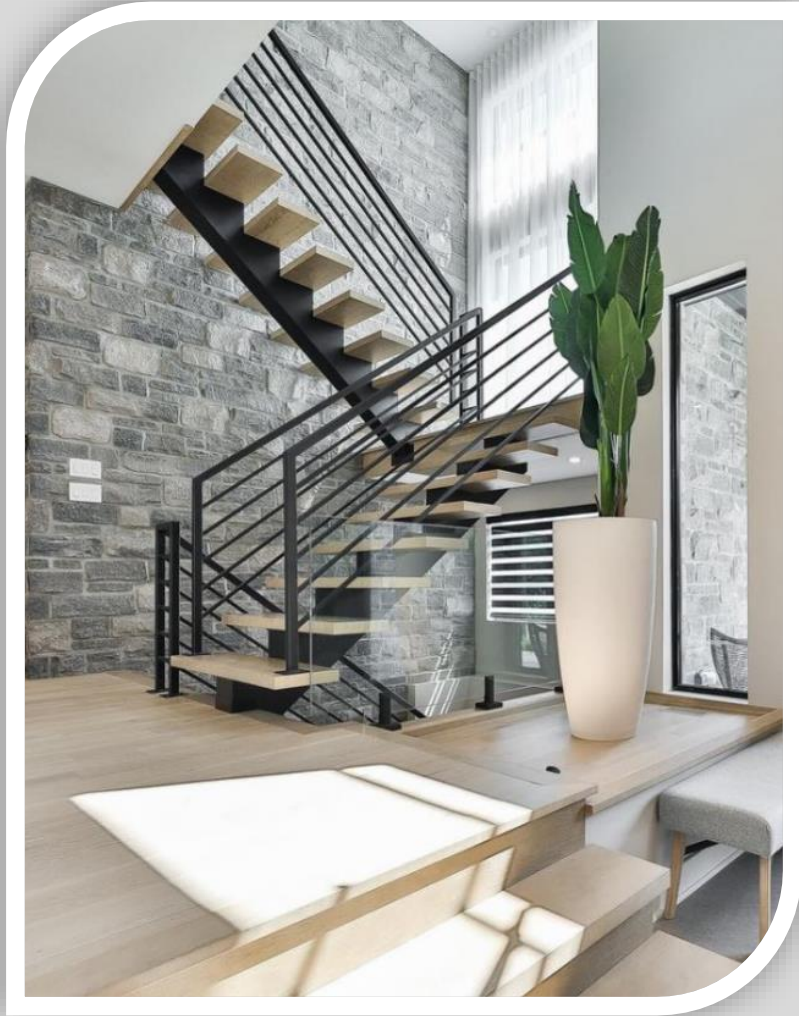

The Seattle – Stringer Detail

TOP OF THE STAIRS

Option of an upper fixed plate of 1 5/8"

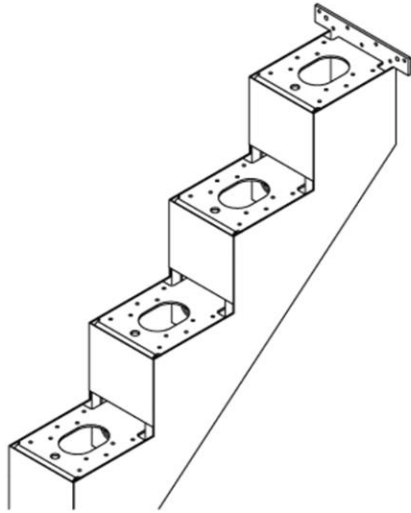

Option of an upper fixed plate of 6"

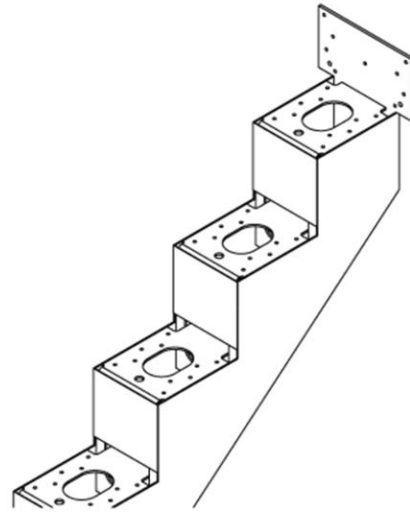

BOTTOM OF THE STAIRS

Option Plat
Interior fixing plate

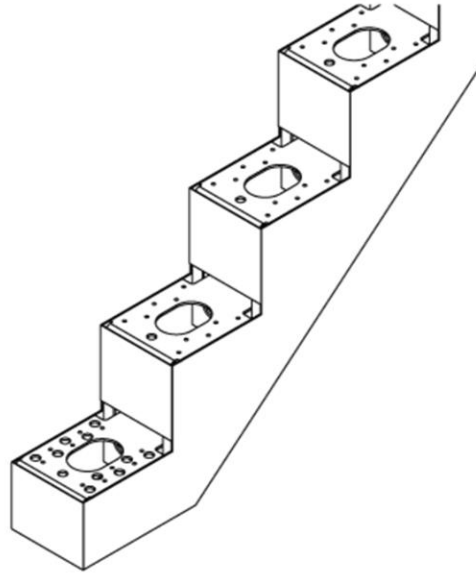

Option Angle
Fixed with an angle mounting plate

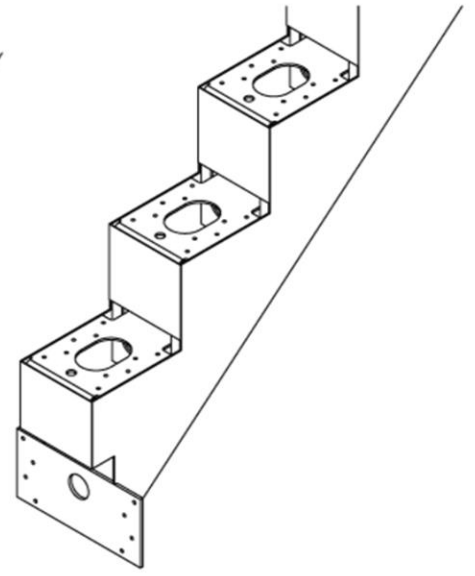

Powder-Coat Color Options

