



Built in Sweden.  
Trusted Worldwide.

ENG

# GANTERUD Pro Range

## User manual

Version 4.0. 2026



**GANTERUD  
L5 Pro**



**GANTERUD  
L12 Pro**



**GANTERUD  
L20-3 Pro**

# EC Declaration of Conformity

---

According to 2006/42/EC, Annex 1, Sections 1 and 4 (AFS 2008:3, Annex 2A).  
ORIGINAL

Manufacturer / representative: Ganterud Lifting Solutions AB.

Address: Frögatan 10, SE 653 36 Karlstad.

---

## Hereby declares that

Machine / installation: Levelling equipment Pro Range.  
Serial number: Ganterud L5 Pro: L5P-5216-101 onwards  
Ganterud L12 Pro: L12P-151-001 onwards  
Ganterud L20-3 Pro: L20P-201-101 onwards

Complies with relevant parts of the following directives:

The Machinery Directive 2006/42/EC, Annex 1, Sections 1 and 4.

The EMC Directive 2014/30/EU.

The Low Voltage Directive 2014/35/EU.

Satisfies where applicable the requirements in standards and specifications listed below:

SS EN ISO 12100-2010	SS EN 13155+A2:2009
SS EN 61000-6-4	SS EN 60204-1
SS EN 61000-6-2	ELSÄK-FS 2008:1-4

Karlstad, 06/02/2026

.....  
Place and date

Frögatan 10, SE 653 36 Karlstad

.....  
Address

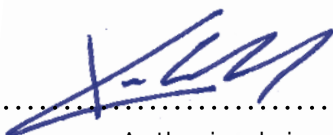
.....  

Authorised signatory

.....  
Kristoffer Ganterud

Name in block capitals

# Contents

<b>1 Introduction</b> .....	<b>4</b>	<b>4 Operation</b> .....	<b>12</b>
1.1 About this manual.....	4	4.1 Daily inspection.....	12
1.2 Disclaimer.....	4	4.1.1 Before use .....	12
1.4 Contact information.....	4	4.1.2 After use .....	12
1.3 Warranty and complaints .....	4	4.2 Operating the levelling equipment .....	13
<b>2 Safety</b> .....	<b>6</b>	4.2.1 Preparations.....	13
2.1 Definition of safety levels .....	6	4.2.2 Normal use .....	13
2.2 Signs on the levelling equipment .....	6	4.3 Release/snatch block function .....	14
2.3 General .....	6	4.4 Calibration of the neutral position .....	14
2.4 Incorrect handling .....	7	4.5 Synchronising new remote control with levelling equipment .....	15
2.4.3 Impact .....	7	<b>5 Technical data</b> .....	<b>16</b>
2.4.6 Unloading the levelling equipment .....	7	5.1 GANTERUD L5 Pro .....	16
2.4.1 Load imbalance .....	7	5.2 Load capacity GANTERUD L5 Pro.....	17
2.4.4 Centring .....	7	5.3 Load table GANTERUD L5 Pro .....	17
2.4.2 Lifting with one hook .....	7	5.4 GANTERUD L12 Pro .....	18
2.4.5 Long load .....	7	5.5 Load capacity GANTERUD L12 Pro .....	19
2.5 Safety during operation .....	8	5.6 Load table GANTERUD L12 Pro .....	19
<b>3 Description</b> .....	<b>9</b>	5.7 GANTERUD L20-3 Pro.....	20
3.1 Overview .....	9	5.8 Load capacity GANTERUD L20-3 Pro .....	21
3.2 Levelling expressed as height difference ...	10	5.9 Load table GANTERUD L20-3 Pro .....	21
3.3 Remote control.....	11	<b>6 Maintenance</b> .....	<b>22</b>
3.4 Intended use.....	11	6.1 Charging the batteries of the levelling equipment.....	22
3.5 Disposal.....	11	6.2 Replacing batteries in the remote control ...	22
		6.4 Storage and transport.....	23
		6.5 Cleaning.....	23
		6.6 Inspection.....	23

We reserve the right to alter specifications or designs without prior notification, and make reservation for any factual errors. Variations in specifications and equipment standards may occur between different geographical markets. Please contact us for more information regarding applicable product specifications and local adaptations.

# 1 Introduction

## 1.1 About this manual

Keep this user manual for future use – the manual must be available when using the levelling equipment.

## 1.2 Disclaimer

Ganterud Lifting Solutions AB is not liable or bound by guarantees if these instructions are not adhered to during operation, transport, storage or maintenance.

Ganterud Lifting Solutions AB reserves the right to modify the product, component parts, specifications and the content of this manual without prior notification.

Ganterud Lifting Solutions AB accepts no liability for any interventions in or modifications to the product that have been made without Ganterud Lifting Solutions AB's written consent. The product's type approval will cease to apply in the event of any modifications.

## 1.3 Warranty and complaints

Ganterud Lifting Solutions AB guarantees that the product will be free from defects for a period of one (1) year from the date of delivery, provided the levelling equipment has been used, serviced and maintained in the prescribed manner.

During the warranty period, Ganterud Lifting Solutions AB will repair or replace products and component parts that are returned to Ganterud Lifting Solutions AB with shipping charges prepaid.

Ganterud Lifting Solutions AB reserves the right, on a case by case basis, to determine whether the warranty is valid or not.

The warranty will be invalid if the product or its component parts have been subjected to incorrect use, misuse, negligence or accidents.

The warranty will be invalid if the product has been modified or repaired by an unauthorised party as per the specification in this manual.

The warranty will become invalid if the product has been altered or modified using components other than those specified by Ganterud Lifting Solutions AB.

The purchaser must inspect the product promptly following receipt, and must notify Ganterud Lifting Solutions AB's head office in writing about any claims, including claims regarding breach of warranty, within thirty days after the purchaser has discovered, or ought to have discovered, the facts on which the warranty claim is based.

Failure by the purchaser to submit written notification of a warranty claim within this time period will be deemed to be a waiver of such claim.

## 1.4 Contact information

Ganterud Lifting Solutions AB, [www.ganterud.se](http://www.ganterud.se)

For support or other information about the product, please contact Ganterud Lifting Solutions AB:

e-mail: [info@ganterud.se](mailto:info@ganterud.se)

Tel. during office hours: +46 70 281 20 08



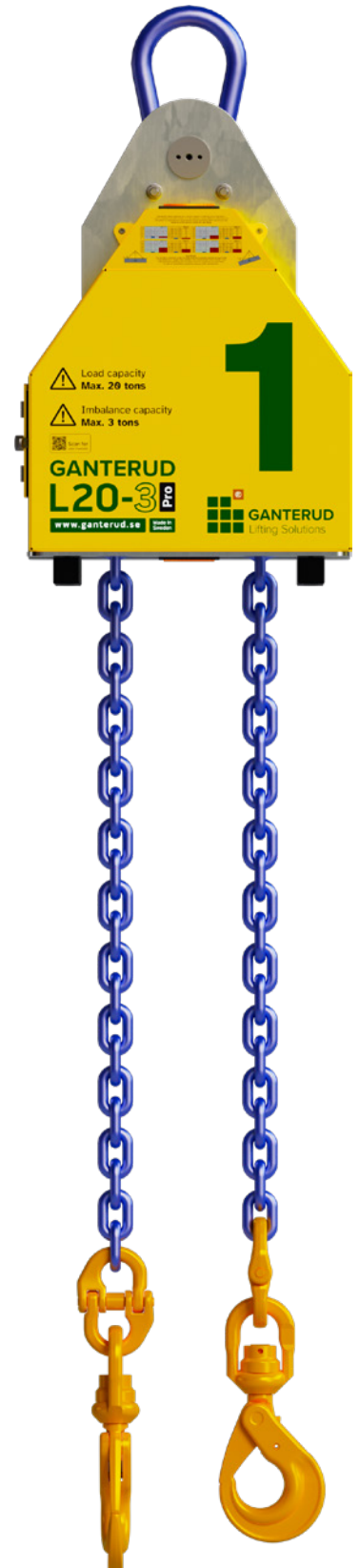

# Built in Sweden. Trusted Worldwide.

Whether you are installing precast concrete walls, steel beams or industrial machinery, Ganterud's technology saves valuable crane time and reduces the risks of manual handling.

# 2 Safety

## 2.1 Definition of safety levels



### WARNING

*Specifies a potentially hazardous situation that, if not avoided, may result in death or serious injury.*



### NOTE

*Specifies a potentially hazardous situation that, if not avoided, may result in minor or moderate injury as well as damage to property.*

## 2.2 Signs on the levelling equipment

- Rating plate, CE marking
- Warning of the risk of crushing between chain and metal housing.
- Max. load
- Max. load imbalance
- Max. chain angle
- Instructions for correct operation
- Load table

## 2.3 General



### WARNING

*Incorrect use may result in death or serious injury to a person and/or damage to property.*

- Please read this manual carefully before using the levelling equipment.
- The levelling equipment may only be used by an operator who has good knowledge and training of the levelling equipment.
- The levelling equipment may only be operated by personnel standing on a firm surface and who have a clear view of the load.
- Never use the release/snatch block function when the load has left the ground.
- The levelling equipment is only intended for lifting with the load in a hook/sling. Any other use is prohibited.
- The levelling equipment must not be used if the fixed protection covering rotating parts is damaged or has been removed.
- All lifting aids used together with the levelling equipment must be provided with built-in scales. Alternatively, the weight must be known and documented. This prevents overloading of the levelling equipment.
- Take care when handling the levelling equipment. There is a risk of crushing between the chain and the metal housing.
- **Before handling the load, the remote control should be used to run the chains so that they are equally tensioned on both sides. When the chains are tensioned, the release function can be used to allow the levelling equipment to find the centre of gravity of the load. It is not permitted to use the crane to tension the chains. The chains should always be tensioned with the remote control before releasing.**

## 2.4 Incorrect handling

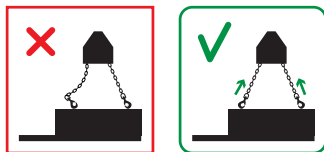

*The chain must be tensioned on both sides before lifting may be carried out. See section 2.3 "Before load handling"*

## 2.4.1 Load imbalance

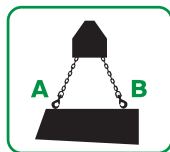

*The levelling equipment must not be imbalanced. See load table for maximum load difference.*

## 2.4.2 Lifting with one hook

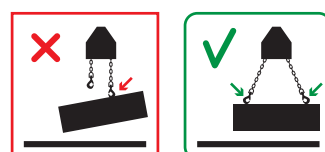

*Both hooks must be used when lifting! The levelling equipment must not be used for lifting and hoisting using only one hook.*

## 2.4.3 Impact

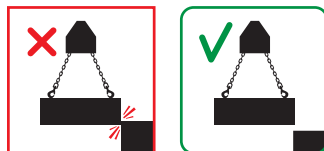

*The levelling equipment may be damaged in case of impact.*

## 2.4.4 Centring

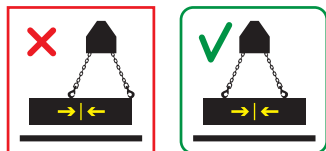

*The levelling equipment must be centred over the centre of gravity of the load within the specified margin of error as shown in the load table.*

## 2.4.5 Long load

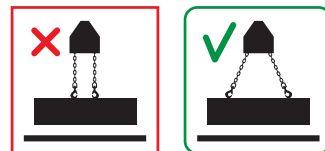

*The chain angle must be as wide as possible when levelling, although not exceeding 60° between chains, to reduce the strain on the levelling equipment in the event the load should start to swing.*

## 2.4.6 Unloading the levelling equipment

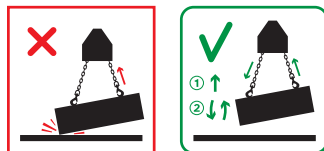

*Disengage the brake before lifting begins. Lift the load and level it once it is freely suspended. The load must be horizontal when placed on a flat surface, or the load on both attachment points must be relieved at the same time.*

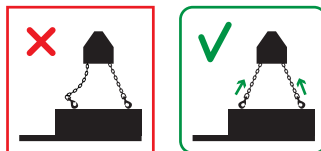

*The chain must be tensioned on both sides before lifting may be carried out. See section 2.3 "Before load handling"*

## 2.5 Safety during operation



### WARNING

*Incorrect handling or a lack of control can expose personnel to danger of death!*

- Perform a daily inspection of the levelling equipment before each use.
- Perform a load inspection before each lift.
- The levelling equipment may only be operated using remote control, where the operator is standing on a firm surface and has a clear view of the load.
- Never use the release/snatch block function when the load has left the ground.
- The levelling equipment is not intended for lifting people. Do not stand on or under a suspended load.
- Connect the hook/shackle directly to the load, or via a chain or sling to the load.
- Check that the safety lock on each hook/the pin on each shackle is properly locked.
- The entire load must be securely lashed to avoid falling items when lifting.
- The chain must be tensioned on both sides before lifting may be carried out.
- Lift the load slowly to minimise acceleration forces.
- Load handling and load movement or lowering may be dangerous. Adapt the speed to minimise the danger to people and equipment.
- Keep a careful lookout for people moving within the risk zone. Make them aware that load handling is in progress.
- Observe the load constantly during operation.
- Make sure that nobody is at risk of being crushed by the load when it is lowered, or pushed in the event the load should start to swing.



### WARNING

Ganterud Lifting Solutions AB can only give general advice as each type of lifting/levelling is unique, and has different and variable loads when levelling depending on Ganterud's levelling equipment and the object being lifted. We therefore recommend that you always use crane scales if uncertain.

Ganterud Lifting Solutions AB accepts no responsibility for the use of our Ganterud levelling equipment as it is always the operator/user/company that has ultimate responsibility for correct lifting according to the specifications.

# 3 Description

The GANTERUD Pro Range is a radio-controlled levelling device used for precision adjustment of heavy objects, such as building elements, beams, roof trusses, etc. when lifted with a crane or other lifting device. The levelling equipment is powered by a built-in electric motor fitted with a rechargeable battery, and can be used with most types of cranes and lifting devices.

## 3.1 Overview

1. Remote control.
2. Lower warning light – free wheel function activated.
3. Upper warning light – free wheel function activated.
4. Main switch – Cuts off the power supply to the motor and other electrical and electronic components. Must be switched off when the batteries are being charged.
5. Battery indicator. Indicates battery status. 25 - 100%.
6. Batteries.
7. Battery charger.
8. Cable for battery charger. Connected to 110V-230V AC 50 Hz for charging batteries. Always switch off the levelling equipment before charging.
9. Contact, according to local market.

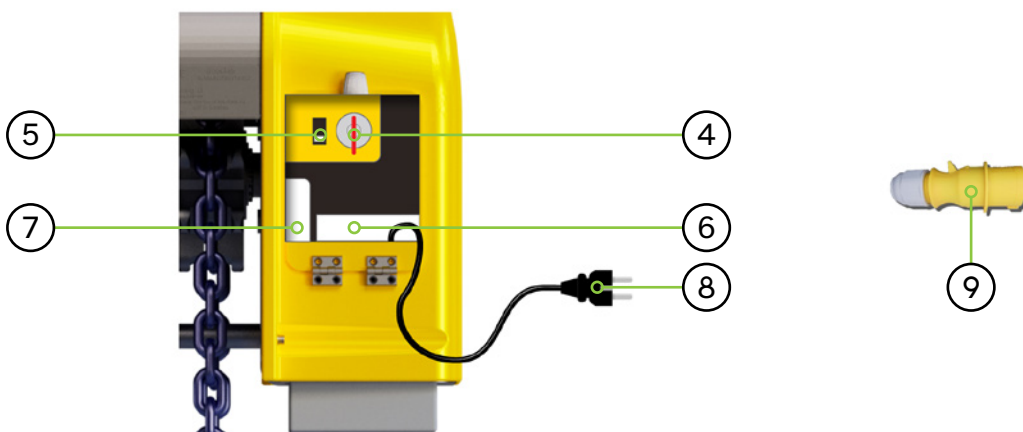

## 3.2 Levelling expressed as height difference

The table below shows the height difference that various levelling angles equate to for lifting objects of different lengths. All lengths are specified in millimetres (mm).

If necessary, the height difference can be calculated by multiplying the length of the object being lifted by the sine:

$$h = L \times \sin(a)$$

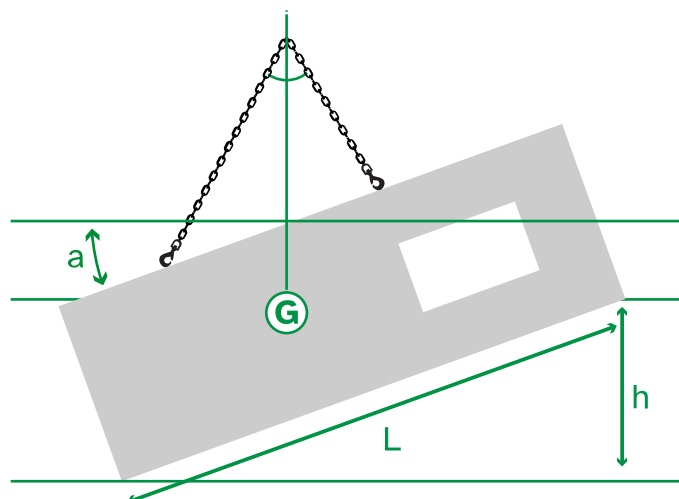

Height difference, h [mm]								
a [°]	L [mm]							
	1000	2000	3000	4000	5000	6000	7000	8000
1	17	35	52	70	87	105	122	140
2	35	70	105	140	174	209	244	279
3	52	105	157	209	262	314	366	419
4	70	140	209	279	349	419	488	558
5	87	174	261	349	436	523	610	697
6	105	209	314	418	523	627	732	836
7	122	244	366	487	609	731	853	975
8	139	278	418	557	696	835	974	1113
9	156	313	469	626	782	939	1095	1251
10	174	347	521	695	868	1042	1216	1389
11	191	382	572	763	954	1145	1336	1526
12	208	416	624	832	1040	1247	1455	1663
13	225	450	675	900	1125	1350	1575	1800
14	242	484	726	968	1210	1452	1693	1935
15	259	518	776	1035	1294	1553	1812	2071
16	276	551	827	1103	1378	1654	1929	2205
17	292	585	877	1169	1462	1754	2047	2339
18	309	618	927	1236	1545	1854	2163	2472
19	326	651	977	1302	1628	1953	2279	2605
20	342	684	1026	1368	1710	2052	2394	2736



### 3.3 Remote control

The levelling equipment is fitted with radio control and is operated with the remote control handset supplied.

The remote control is calibrated for the levelling device, using a specific radio frequency. This means that several levelling devices can be used with their own remote controls on the same work site, without disrupting each other.

If several remote controls are used on the same work site, and for some reason are using the same radio frequency, there is a risk of them disrupting each other. In this case, it is necessary to change the radio frequency of the affected remote controls and receivers.

Changing the radio frequency may only be performed by authorised personnel.

### 3.4 Intended use

The levelling equipment is designed for levelling with a maximum chain angle of 60°.

The levelling equipment can be used both indoors and outdoors, within a temperature range of -20°C to +40°C.

### 3.5 Disposal

Disposal must take place in accordance with local rules and regulations.

# 4 Operation

## 4.1 Daily inspection



### WARNING

*Each and every one of the checkpoints below must be approved before the GANTERUD Pro Range is used.*

### 4.1.1 Before use

#### CHECK:

- that the batteries in the levelling equipment are charged
- whether the batteries in the remote control need to be replaced
- that the main power switch is set to the On position
- that no mechanical damage is present on the product
- that no mechanical obstacles are present on and around the chain
- that no damage is present on the chain, the entire chain must be inspected
- that the chain and lifting hooks are intact and clean
- that the locking mechanisms on the lifting hooks are working
- that the decals are clearly legible

### 4.1.2 After use

#### CHECK:

- whether the batteries in the levelling equipment need to be charged; always switch off the equipment before doing so.
- whether the batteries in the remote control need to be replaced
- that the main power switch is set to the Off position
- that no mechanical damage is present on the product
- that no mechanical obstacles are present on and around the chain
- that no damage is present on the chain, the entire chain must be inspected
- that the chain and lifting hooks are intact and clean
- that the locking mechanisms on the lifting hooks are working
- that the decals are clearly legible



### WARNING

Ganterud Lifting Solutions AB can only give general advice as each type of lifting/levelling is unique, and has different and variable loads when levelling depending on Ganterud's levelling equipment and the object being lifted. We therefore recommend that you always use crane scales if uncertain.

Ganterud Lifting Solutions AB accepts no responsibility for the use of our Ganterud levelling equipment as it is always the operator/user/company that has ultimate responsibility for correct lifting according to the specifications.

## 4.2 Operating the levelling equipment

### 4.2.1 Preparations

- Load control must be performed by the responsible operator.
- Plan the lift/levelling and carry out a risk analysis (see applicable local regulations and work instructions).
- Make sure that daily inspection is performed (see “Daily inspection” under section 4.1).
- Make sure that the levelling equipment is free from damage that could jeopardise safety.
- Check that the battery charger on the levelling equipment is disconnected from the power source.
- Check that the door to the levelling equipment is closed.

### 4.2.2 Normal use



#### WARNING

**Loaded levelling equipment must be operated in slow mode!**



#### NOTE

*When using the levelling equipment in certain situations, noise and vibration may occur in the levelling equipment. It is perfectly normal and occurs when the chain is in motion during levelling.*



## 4.3 Release/snatch block function



### NOTE

*The load on the levelling equipment must be relieved fully when the release/snatch block function is activated.*

*Never use the release/snatch block function when the load has left the ground.*

The brake on the levelling equipment can be disengaged.

For example, this function can be used to check the equilibrium of the load before the actual lift/levelling takes place. In some cases, a load of up to a tonne may be needed on one hook to activate the release, depending on the chain angle and the type of object being lifted. You can then use the remote control so the chain on both sides is tensioned.

The release/snatch block function is controlled as follows:

**A** – Press the release buttons (marked RELEASE) on the remote control simultaneously until the warning lights on the levelling equipment start to flash. The release/snatch block function is now activated.

**B** – The release/snatch block function is deactivated by pressing either button 1 or button 2.



### NOTE

Before handling the load, the remote control should be used to run the chains so that they are equally tensioned on both sides. When the chains are tensioned, the release function can be used to allow the levelling equipment to find the centre of gravity of the load. It is not permitted to use the crane to tension the chains. The chains should always be tensioned with the remote control before releasing.



## 4.4 Calibration of the neutral position

When levelling, the chain's end positions are governed by the neutral position that is calibrated in the factory. This should not normally need to be recalibrated.

Contact Ganterud Lifting Solutions AB if you have any questions.

## 4.5 Synchronising new remote control with levelling equipment

If the old remote control has to be replaced, or if you want to have two remote controls for one levelling device.

### Deleting:

Ensure that the levelling equipment is switched off using the power switch, and that the new remote control is switched off.

1. Turn on the new remote control
2. Turn on the main power switch on the levelling device
3. Press **button "1" and button "A"** on the remote control at the same time for approx. 5 seconds. The old remote control has now been deleted in the levelling equipment.

Press the various buttons to check that no function is active. NB: take care and monitor the levelling device to make sure that no risk of injury can arise.

### Synchronising:

Switch off the levelling equipment with the main power switch, and turn off the new remote control.

1. Turn on the new remote control
2. Turn on the main power switch on the levelling device
3. Press both arrow keys (**button "1" and button "2"**) on the new remote control for approx. 5 seconds. The new remote control is now synchronised with the levelling equipment.



**Test all functions of the levelling equipment. NB: take care and monitor the levelling device to make sure that no risk of injury can arise.**

# 5 Technical data

## 5.1 GANTERUD L5 Pro

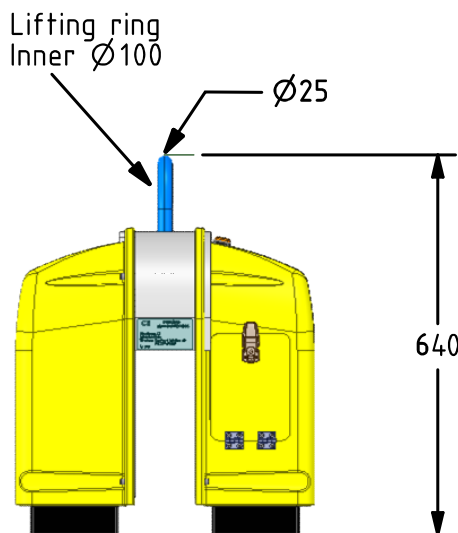
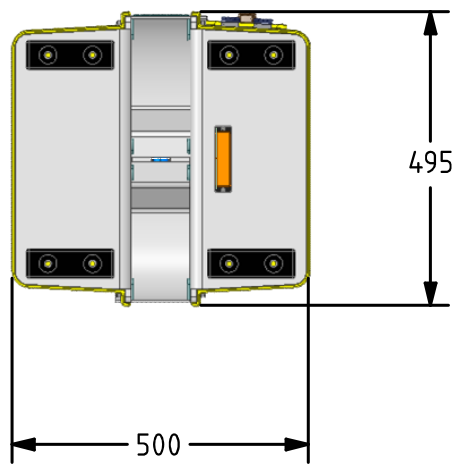

### Technical data

Load capacity: Max. 5 tonnes  
Max. load imbalance: Max. 750 kg.  
Max. levelling length: 3 m in standard version (1.5 m in both directions)  
Two levelling speeds.  
Max. chain angle: 60° at 5 tonne load.  
Total chain length: 3 m in standard version.  
Chain dimensions: 30.5x10 mm.  
Unloaded weight: Approx. 130 kg (incl. chain and hooks).  
Height: 640 mm.  
Width: 500 mm.  
Depth: 495 mm.

### Control system

Radio range: 100 m unobstructed view  
Voltage, electric motor: 24 VDC  
Power consumption, rest: 50 mA  
Power consumption, max. continuous: 24 A  
Power consumption, peak: 30 A

### Certification

CE marked product

### Environmental requirements

Operating temperature: -20°C to +40°C  
Storage temperature: -20°C to +45°C  
Relative humidity (RH): 0–90% during storage

### Control system for remote control

Number of function buttons: 8  
Power output: 12 MW  
Power supply: 3 x 1.5V AAA  
IP rating: IP67

### Optional extra equipment

Protective cover  
Chain kit in other lengths  
Extra batteries

## 5.2 Load capacity GANTERUD L5 Pro

The maximum load capacity of 5 tonnes and the maximum sling angle of 60° apply on condition that the other restrictions specified in the load table are complied with.

The load table applies under normal use. In case of doubt, scales/load cells must be used to measure the load at each end of the chain. The examples in the load table below are for a uniform load 3 m wide and 1.5 m high with the centre of gravity centrally located.

The chain can carry a maximum of 4 tonnes in the direction of the chain, and the difference between the ends must not exceed 0.75 tonnes. Note that the total weight of the object being lifted must never exceed 5 tonnes.



### NOTE

*Exceeding the maximum sling angle or maximum load capacity will damage the equipment.*

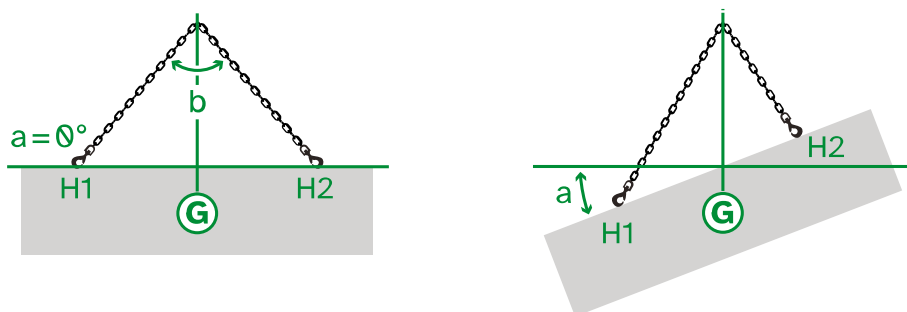

## 5.3 Load table GANTERUD L5 Pro

Load	a°	b°	H1	H2	Difference H1-H2 < 0,75 T	a°	b°	H1	H2	Difference H1-H2 < 0,75 T
2	0	45	1,1	1,1	0,00	0	60	1,2	1,2	0,00
2	5	44	0,9	1,2	0,30	5	59	1,1	1,2	0,20
2	10	43	0,8	1,4	0,60	10	58	1,0	1,3	0,40
2	12	40	0,7	1,4	0,75	18	52	0,7	1,5	0,75
2	16	39	0,5	1,6	1,10	20	50	0,7	1,5	0,90
						23	43	0,5	1,6	1,10

Load	a°	b°	H1	H2	Difference H1-H2 < 0,75 T	a°	b°	H1	H2	Difference H1-H2 < 0,75 T
3,5	0	45	1,9	1,9	0,00	0	60	2,0	2,0	0,00
3,5	5	44	1,6	2,1	0,50	5	59	1,9	2,2	0,30
3,5	7	43	1,5	2,3	0,75	10	58	1,7	2,3	0,60
3,5	10	42	1,4	2,4	1,00	12	57	1,6	2,3	0,75
3,5	20	36	0,5	3,1	2,60	20	50	1,1	2,7	1,50
3,5						26	41	0,5	3,1	2,60

Load	a°	b°	H1	H2	Difference H1-H2 < 0,75 T	a°	b°	H1	H2	Difference H1-H2 < 0,75 T
5	0	45	2,7	2,7	0,00	0	60	2,9	2,9	0,00
5	5	44	2,3	3,0	0,70	5	59	2,7	3,1	0,40
5	6	44	2,3	3,1	0,75	9	58	2,5	3,2	0,75
5	10	43	1,9	3,4	1,50	10	57	2,4	3,3	0,90
5	20	36	0,8	4,4	3,60	20	50	1,6	3,8	2,20
5	22	35	0,5	4,6	4,10	28	40	0,5	4,6	4,10

## 5.4 GANTERUD L12 Pro

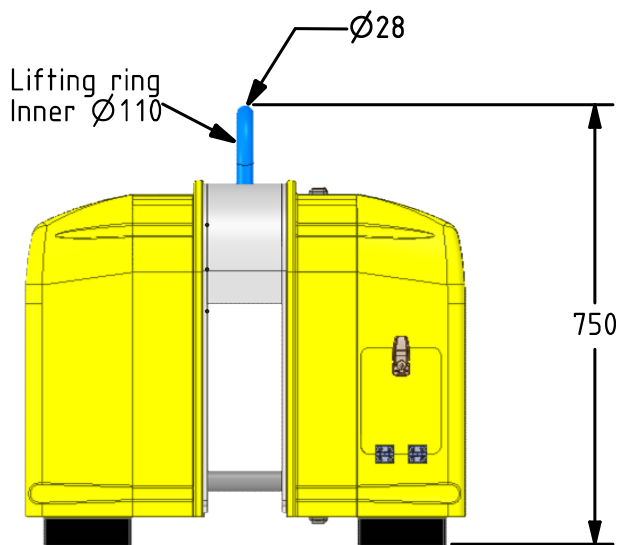
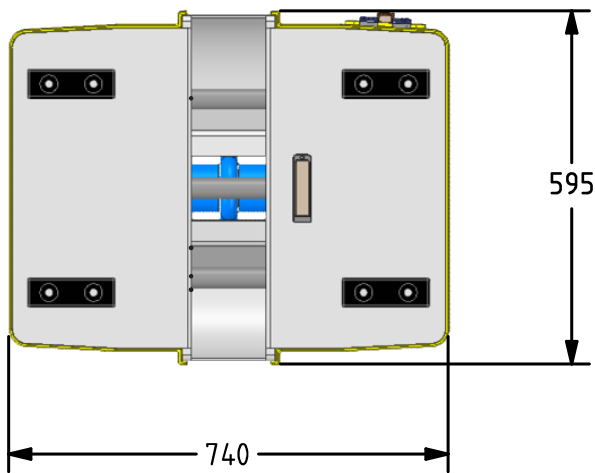

### Technical data

Load capacity: Max. 12 tonnes

Max. load imbalance: Max. 2.5 tonnes

Max. levelling length: 4 m in standard version (2 m in both directions).

Two levelling speeds.

Max. chain angle: 60 degrees between chains at 12 tonne load.

Total chain length: 4 m in standard version.

Chain dimensions: 48x16 mm

Unloaded weight: Approx. 295 kg (incl. chain and hooks).

Height: 750 mm.

Width: 740 mm.

Depth: 595 mm.

### Control system

Radio range: 100 m unobstructed view

Voltage, electric motor: 24 VDC

Power consumption, rest: 50 mA

Power consumption, max. continuous: 24 A

Power consumption, peak: 30 A

### Certification

CE marked product

### Environmental requirements

Operating temperature: -20°C to +40°C

Storage temperature: -20°C to +45°C

Relative humidity (RH): 0–90% during storage

### Control system for remote control

Number of function buttons: 8

Power output: 12 MW

Power supply: 3 x 1.5V AAA

IP rating: IP67

### Optional extra equipment

Protective cover

Chain kit in other lengths

Extra batteries

## 5.5 Load capacity GANTERUD L12 Pro

The maximum load capacity of 12 tonnes and the maximum sling angle of 60° apply on condition that the other restrictions specified in the load table are complied with.

The load table applies under normal use. In case of doubt, scales/load cells must be used to measure the load at each end of the chain. The examples in the load table below are for a uniform load 4 m wide and 3 m high with the centre of gravity centrally located.

The chain can carry a maximum of 8 tonnes in the chain's direction, and the difference between the ends must not exceed 2.5 tonnes. Note that the total weight of the object being lifted must never exceed 12 tonnes.



### NOTE

*Exceeding the maximum sling angle or maximum load capacity will damage the equipment.*

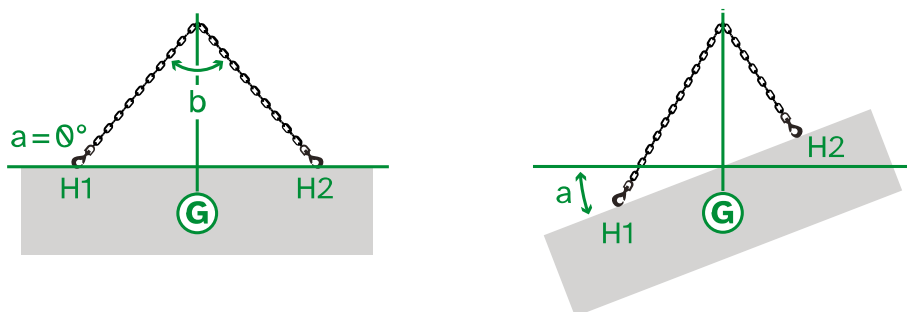

## 5.6 Load table GANTERUD L12 Pro

Load	a°	b°	H1	H2	Difference H1-H2 < 2,5 T	a°	b°	H1	H2	Difference H1-H2 < 2,5 T
4	0	45	2,2	2,2	0,0	0	60	2,3	2,3	0,0
4	5	44	1,9	2,4	0,5	5	59	2,1	2,5	0,4
4	10	43	1,6	2,7	1,0	10	58	1,9	2,7	0,9
4	20	39	1,1	3,1	2,0	20	53	1,4	3,1	1,7
4	25	36	0,8	3,3	2,5	30	45	0,9	3,4	2,5
4	30	32	0,5	3,5	3,0	37	37	0,5	3,6	3,1
4	31	31	0,5	3,6	3,0					

Load	a°	b°	H1	H2	Difference H1-H2 < 2,5 T	a°	b°	H1	H2	Difference H1-H2 < 2,5 T
8	0	45	4,3	4,3	0,0	0	60	4,6	4,6	0,0
8	5	44	3,8	4,8	1,0	5	59	4,2	5,0	0,9
8	10	43	3,3	5,3	2,0	10	58	3,7	5,4	1,7
8	12	42	3,0	5,5	2,5	14	57	3,3	5,8	2,5
8	20	39	2,2	6,2	4,0	20	53	2,7	6,1	3,4
8	30	32	1,1	7,1	6,0	30	45	1,7	6,7	5,0
8	35	27	0,5	7,6	7,0	40	32	0,7	7,4	6,7
						41	30	0,5	7,6	7,1

Load	a°	b°	H1	H2	Difference H1-H2 < 2,5 T	a°	b°	H1	H2	Difference H1-H2 < 2,5 T
12	0	45	6,5	6,5	0,0	0	60	6,9	6,9	0,0
12	5	44	5,7	7,3	1,5	5	59	6,3	7,6	1,3
12	8	44	5,2	7,7	2,5	9	58	5,6	8,1	2,5
12	10	43	4,9	8,0	3,1	10	57	5,6	8,1	2,6
12	20	39	3,3	9,3	6,1	20	53	4,1	9,2	5,1
12	30	32	1,6	10,6	9,0	30	45	2,6	10,1	7,6
12	36	26	0,5	11,6	11,0	40	32	1,0	11,1	10,1
						43	27	0,5	11,6	11,1

## 5.7 GANTERUD L20-3 Pro

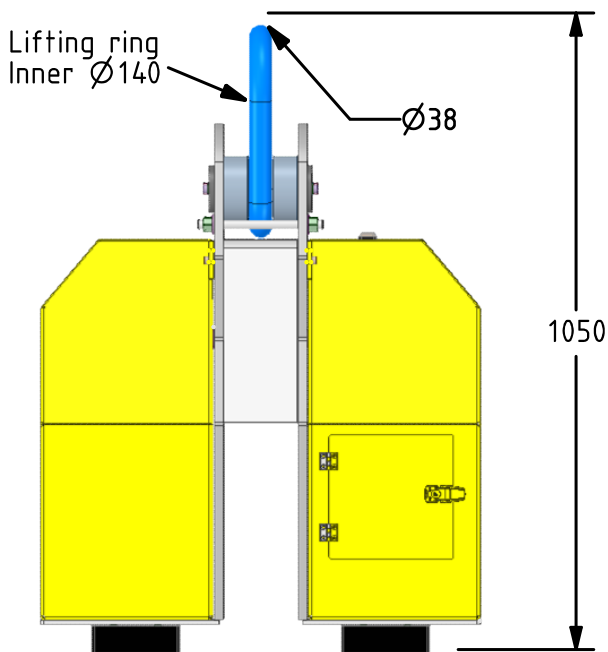
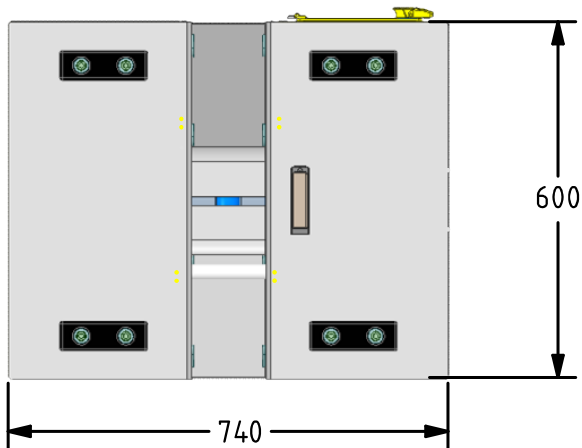

### Technical data

Load capacity: Max. 20 tonnes

Max. load imbalance: Max. 3 tonnes

Max. levelling length: 6 m in standard version (3 m in both directions).

Two levelling speeds.

Max. chain angle: 60 degrees between the chains with a 20 tonne load.

Total chain length: 6 m in standard version.

Chain dimensions: 60x20 mm.

Net weight 395 kg (Incl. chain and hooks)

Height 1050mm

Width 740 mm

Depth 600 mm

### Control system

Radio range: 100 m unobstructed view

Voltage, electric motor: 24 VDC

Power consumption, rest: 50 mA

Power consumption, max. continuous: 60 A

Current consumption Peak 100 A

### Certification

CE marked product

### Environmental requirements

Operating temperature: -20°C to +40°C

Storage temperature: -20°C to +45°C

Relative humidity (RH): 0–90% during storage

### Control system for remote control

Number of function buttons: 8

Power output: 12 MW

Power supply: 3 x 1.5V AAA

IP rating: IP67

### Optional extra equipment

Protective cover

Chain kit in other lengths

Extra batteries

## 5.8 Load capacity GANTERUD L20-3 Pro

The maximum load capacity of 20 tonnes and the maximum sling angle of 60° apply on condition that the other restrictions specified in the load table are complied with.

The load table applies under normal use. In case of doubt, scales/load cells must be used to measure the load at each end of the chain. The examples in the load table below are for a uniform load 6 m wide and 2,5 m high with the centre of gravity centrally located.

The chain can carry a maximum of 12.5 tonnes in the direction of the chain, and the difference between the ends must not exceed 3 tonnes. Note that the total weight of the object being lifted must never exceed 20 tonnes.



### NOTE

*Exceeding the maximum sling angle or maximum load capacity will damage the equipment.*

## 5.9 Load table GANTERUD L20-3 Pro

Load	a°	b°	H1	H2	Difference H1-H2 < 3 T	a°	b°	H1	H2	Difference H1-H2 < 3 T
5	0	45	2,7	2,7	0,0	0	60	2,9	2,9	0,0
5	5	44	2,6	2,8	0,3	5	59	2,8	2,9	0,1
5	10	43	2,4	3,0	0,5	10	58	2,8	3,0	0,2
5	20	40	2,0	3,3	1,2	20	55	2,6	3,1	0,5
5	30	34	1,4	3,7	2,3	30	47	2,2	3,3	1,1
5	34	31	1,1	4,1	3,0	40	37	1,5	3,7	2,3
5	39	27	0,5	4,5	4,0	43	32	1,1	4,1	3,0
						47	28	0,5	4,5	4,0

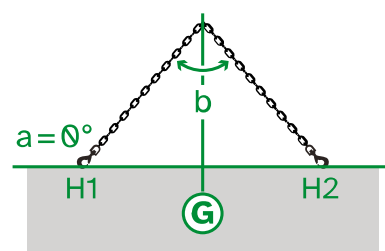

Load	a°	b°	H1	H2	Difference H1-H2 < 3 T	a°	b°	H1	H2	Difference H1-H2 < 3 T
10	0	45	5,4	5,4	0,0	0	60	5,8	5,8	0,0
10	5	44	5,1	5,7	0,5	5	59	5,7	5,9	0,2
10	10	43	4,8	5,9	1,1	10	58	5,5	5,9	0,4
10	20	40	4,1	6,5	2,5	20	54	5,1	6,1	1,0
10	23	39	3,8	6,8	3,0	30	51	4,4	6,5	2,1
10	30	34	2,9	7,5	4,6	35	43	3,8	6,8	3,0
10	40	30	0,7	9,4	8,7	40	37	2,9	7,5	4,5
10	41	25	0,5	9,5	9,0	48	26	0,5	9,5	9,0

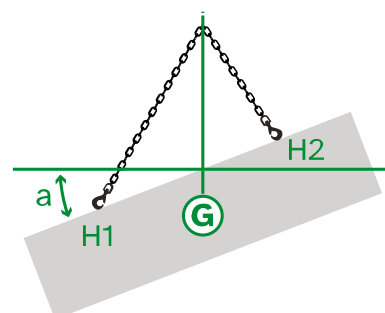

Load	a°	b°	H1	H2	Difference H1-H2 < 3 T	a°	b°	H1	H2	Difference H1-H2 < 3 T
15	0	45	8,1	8,1	0,0	0	60	8,7	8,7	0,0
15	5	44	7,7	8,5	0,8	5	59	8,5	8,8	0,3
15	10	43	7,3	8,9	1,6	10	58	8,3	8,9	0,6
15	17	41	6,5	9,5	3,0	20	54	7,7	9,2	1,5
15	20	40	6,1	9,8	3,7	29	48	6,7	9,7	3,0
15	30	34	4,3	11,2	6,9	30	47	6,6	9,8	3,2
15	40	30	1,1	14,0	13,0	40	37	4,4	11,2	6,8
15	41	24	0,5	14,5	14,0	49	25	0,5	14,5	14,0

Load	a°	b°	H1	H2	Difference H1-H2 < 3 T	a°	b°	H1	H2	Difference H1-H2 < 3 T
20	0	45	10,8	10,8	0,0	0	60	11,5	11,5	0,0
20	5	44	10,3	11,3	1,0	5	59	11,3	11,7	0,4
20	10	43	9,7	11,8	2,2	10	58	11,1	11,9	0,8
20	13	42	9,2	12,2	3,0	20	54	10,3	12,2	2,0
20	20	40	8,2	13,1	4,9	25	51	9,6	12,6	3,0
20	30	34	5,7	15,0	9,2	30	47	8,8	13,0	4,2
20	40	30	1,4	18,7	17,3	40	36	5,9	15,0	9,1
20	41	24	0,5	19,6	19,1	48	24	0,5	19,5	19,0

# 6 Maintenance

- Always remove the levelling equipment from the crane or other lifting device, and place it on the ground before starting maintenance work. The levelling equipment must be placed on a firm surface with access to good lighting.
- Always remove the key from the main switch before starting maintenance work.

## 6.1 Charging the batteries of the levelling equipment

The batteries may only be charged in a well ventilated area. Ensure that the levelling equipment is switched off and the main power switch is disengaged before charging begins.

## 6.2 Replacing batteries in the remote control

The remote control is powered by 3 AAA batteries.

Open the battery pack on the back of the remote control to access the batteries. Replace the old batteries with new batteries and reassemble the remote control. Recycle the old batteries in accordance with local rules and regulations.



## 6.4 Storage and transport

The GANTERUD Pro Range must be stored and transported in the original packaging. The levelling equipment must be stored indoors/protected from the weather and with charged batteries. If the levelling equipment is to be stored for longer than 3 months, the batteries must be connected to trickle charge so that there is no risk of them losing capacity.

In this case, storage may take place at a minimum of -20°C. If this is not possible, the batteries must be removed and stored indoors in an environment that satisfies these requirements.

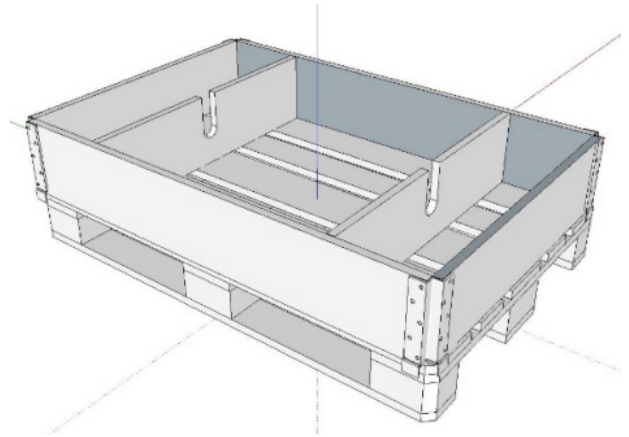

## 6.5 Cleaning

- The levelling equipment must not be cleaned with a pressure washer.
- A hose pipe and a sponge are recommended.
- Never flush up under the plate over the chain wheel.

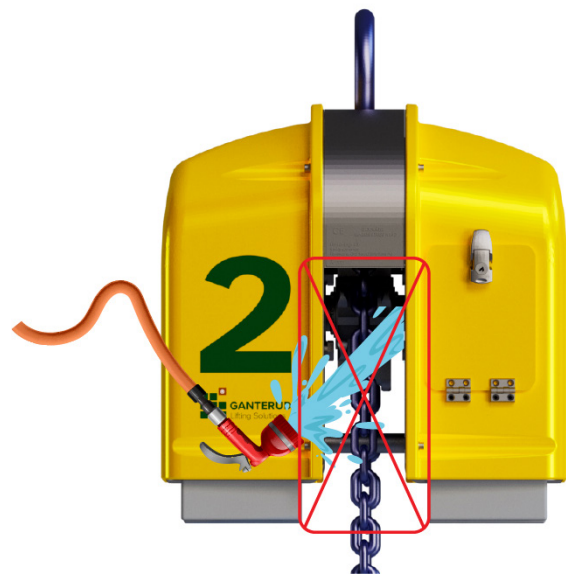

## 6.6 Inspection

- GANTERUD Pro Range – the levelling equipment is not subject to inspection by a 3rd party.
- Visual inspection may be carried out by an inspector designated at the work site.
- Make a note that the check has been carried out.
- The levelling equipment must be inspected and checked every 12 months by one of our approved service partners, and serviced if necessary.
- Contact Ganterud Lifting Solutions AB for more information.



Ganterud Lifting Solutions AB  
Frögatan 10  
SE 653 36 Karlstad  
Sweden  
[www.ganterud.se](http://www.ganterud.se)