



## Industrial strength in capturing:

- WELDING FUMES
- GRINDING DUSTS
- DRY DUSTS
- SOLDERING FUMES
- POWDERS
- PLASMA CUTTING

888-372-0050

[Sales@IAP-AirProducts.com](mailto:Sales@IAP-AirProducts.com)

[www.IAP-AirProducts.com](http://www.IAP-AirProducts.com)

## Industrial Strength Fume Arms



Hanging Arm

Standing Arm

## Industrial Strength Construction

- 1 HOOD JOINT**  
Hood easily positions forward, backward and sideways.  
All external adjustments.  
Flexible hose with gear clamps.
- 2 MIDDLE JOINT**  
All external adjustments.  
195°F Flexible hose with gear clamps.
- 3 SOCKET JOINT**  
Rotating swivel with safety stop, for 180° rotation. All external adjustments. Flexible hose with gear clamps.

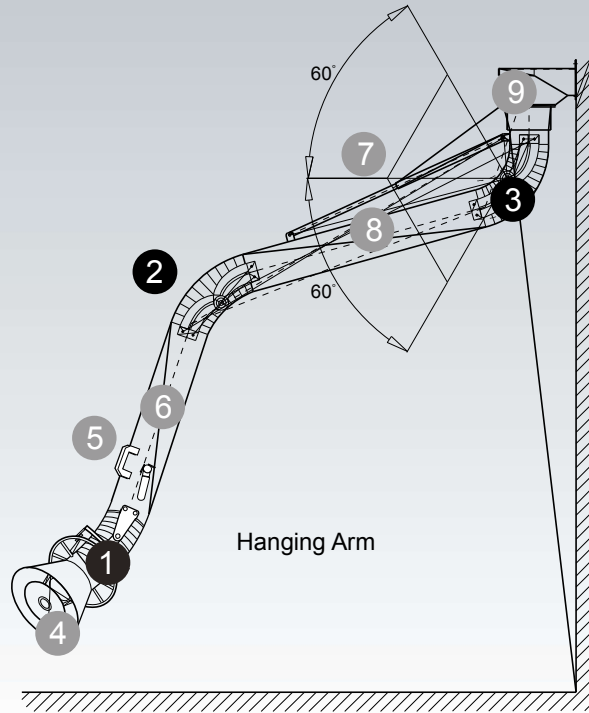
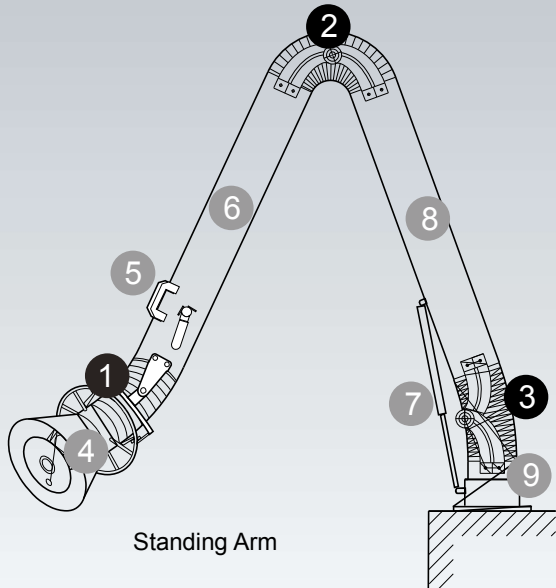

- 4** Aluminium hood (powder coated) with surrounding grab handle.
- 5** Additional tube grab handle.
- 6** Smooth steel tube (powder coated) with standard damper.
- 7** Support spring or gas shock on the outside on both versions.
- 8** Smooth steel tube (powder coated).
- 9** Swivel base with predrilled mounting holes, 350° rotation.

## Comparison

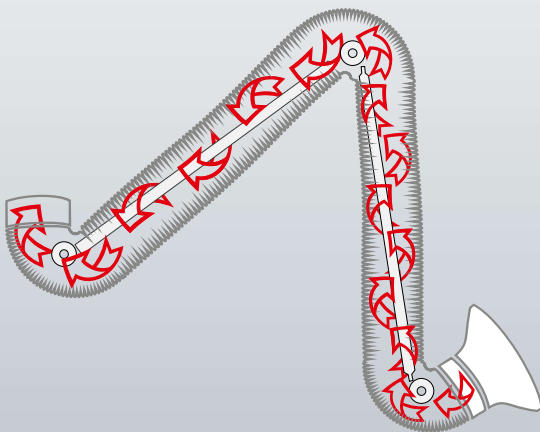

### Other Brands - Internal Components

- restricted airflow
- higher static pressure
- hard to clean
- build up on joint and components

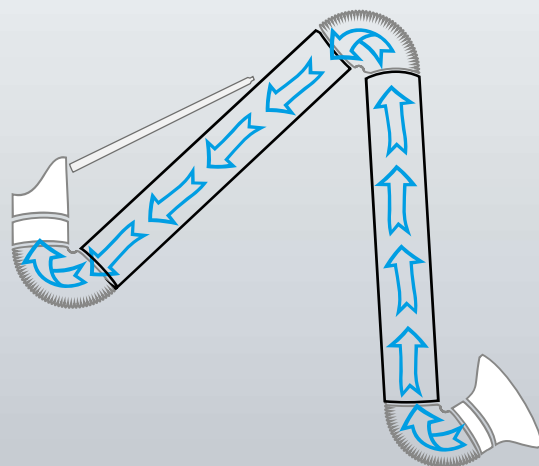

### IAP Fume Arm - External Components

- unrestricted airflow
- lower static pressure
- quick cleaning
- minimal build up

# Industrial Strength Fume Arms



## Applications:

- Welding · Grinding · Polishing · Cutting
- Soldering · Chemical Fumes and many more!

## Features:

- Industrial strength
- Versatile design
- Smooth tube construction
- External joints and supports
- Hood and tube grab handles
- Air diverter in the hood
- Standard damper

## Benefits:

- Long lasting life time
- User-friendly operation
- Higher airflow performance
- Easy to adjust and maintain
- Simple positioning
- Increased capture velocity
- Damper and mounting bracket included

## Standard Hanging Mount Brackets

Bracket type Ø [inches]	n	ØD [inches]	C [inches]	L [inches]	B [inches]	W [inches]	H [inches]	Weight [lb]
3	4	3.0	4.8	8.0	1.0	7.3	5.2	4.2
4	4	4.0	4.9	8.5	1.4	7.9	5.7	4.8
5	6	5.0	5.7	9.9	1.5	9.4	6.5	6.8
6	6	6.0	9.8	14.5	1.3	10.0	6.5	7.9
8	8	8.0	9.8	15.7	1.5	13.9	8.5	13.9

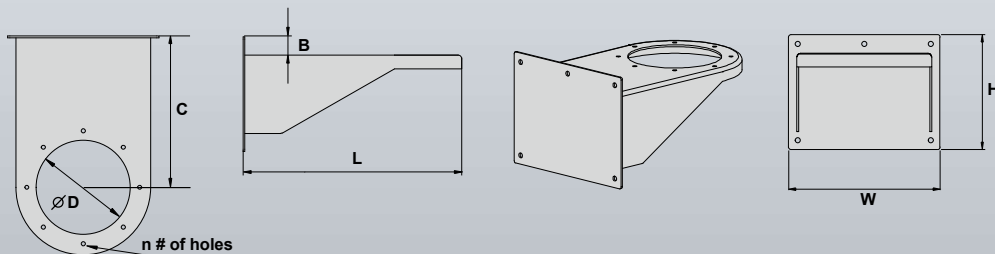

# Industrial Strength Fume Arms

IAP Air Products · 888-372-0050 · Sales@IAP-AirProducts.com

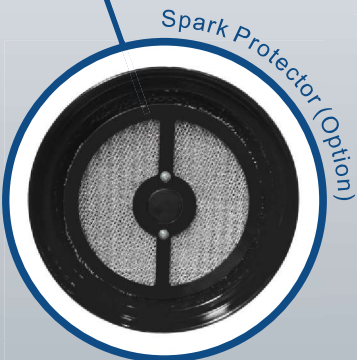
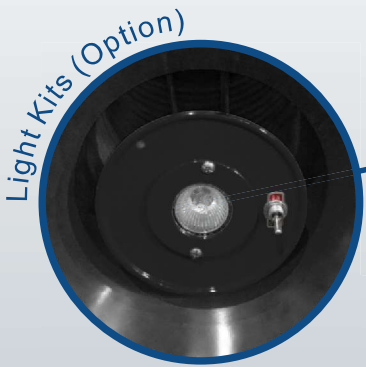

## Technical Data

Arm Part #	Tube Diameter [inches]	Arm Length [Feet]	Hood Diameter [inches]	Ductwork Connection [inches]	Mounting Configuration	CFM range [cfm]	Arm, Bracket and Hood Weight [lbs]
FA-0303	3	3	8	3	Hanging or Standing	150-300cfm	24.4
FA-0305	3	5	8	3	Hanging or Standing	150-300cfm	26.3
FA-0405	4	5	10	4	Hanging or Standing	300-600cfm	26.8
FA-0408	4	8	10	4	Hanging or Standing	300-600cfm	29.5
FA-0507	5	7	10	5	Hanging or Standing	450-750cfm	48.5
FA-0510	5	10	10	5	Hanging or Standing	450-750cfm	52.8
FA-0607	6	7	13	6	Hanging or Standing	600-1200cfm	58.5
FA-0610	6	10	13	6	Hanging or Standing	600-1200cfm	65.8
FA-0614	6	14	13	6	Hanging or Standing	600-1200cfm	73.5
FA-0807	8	7	14	8	Hanging or Standing	950-1800cfm	84.7
FA-0810	8	10	14	8	Hanging or Standing	950-1800cfm	85.4
FA-0814	8	14	14	8	Hanging or Standing	950-1800cfm	99.2

\* All hanging arms include wall bracket and galvanized ductwork connection.

EQUIPMENT OPTIONS			HOOD OPTIONS
Exhaust Fan	Floor Stanchions	Light Kits	20" diameter hoods for 6" arms
Ceiling Stanchions	Extension Booms	Wall Stanchions	20" diameter hoods for 8" arms



### Dealer Information / Contact:



888-372-0050  
 Sales@IAP-AirProducts.com  
 IAP Air Products  
 580 Technology Drive  
 Sparta, TN 38583

**SINGLE SOURCE FOR**  
 Fume / Welding / Dust Arms  
 Ambient Air Cleaners, Mobile Welding Units  
 Dust Collectors, Vehicle Exhaust, etc.  
 at [www.IAP-AirProducts.com](http://www.IAP-AirProducts.com)