

2026 Midwest Biosolids Association

# GHGs and RNG: Greenhouse Gas Emissions of Fond Du Lac WTRRF's Biogas to RNG Project

**Tyler Dougherty**

June 9, 2026



# Agenda

- What is a GHG inventory?
- Fond du Lac background
- Project drivers
- GHG Inventory Tool
  - » System boundaries
  - » Protocols and data gathering
  - » Putting it into practice
- Findings
- Takeaways



01

What is a GHG inventory?

# A step back - introduction to greenhouse gases (GHG)

## CARBON EMISSIONS



## CARBON OFFSETS

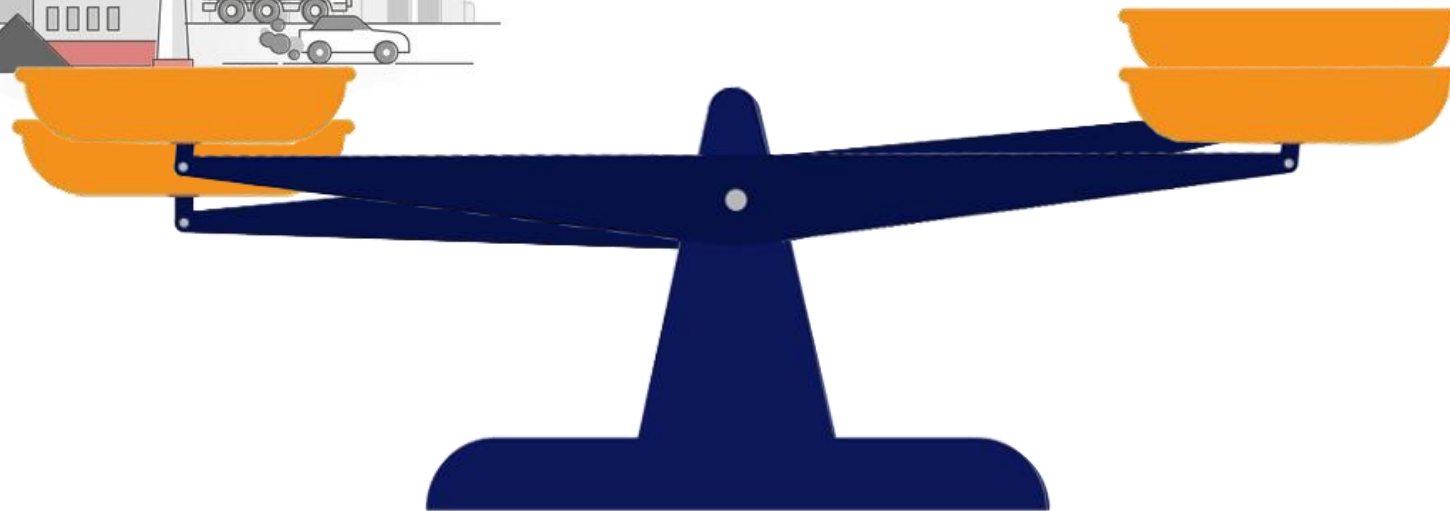

# GHG terminology: Scopes

## Scope 1\*

Direct emissions

- » Onsite stationary combustion



## Scope 2

Indirect emissions

- » Purchased electricity, heat, or steam



## Scope 3

Indirect emissions

- » Purchased materials and uses of end products



\*Regulated emissions include combustion of natural gas and biogas (not including biogenic CO<sub>2</sub>)

# GHG terminology: sources

- Anthropogenic:
  - » Emissions due to **human activity**, such as **burning of fossil fuels** and deforestation leading to higher carbon dioxide concentrations in the air. Land use change (mainly deforestation in the tropics) account for up to one third of total anthropogenic CO<sub>2</sub> emissions
- Biogenic:
  - » Emissions from **natural sources**, such as plants and trees. These are emissions related to the natural carbon cycle, as well as those **resulting from the combustion**, harvest, combustion, digestion, fermentation, decomposition, or processing **of biologically based materials**.



# Not all gases are created equal...

- Not all gases are considered GHGs
  - » Based on ability to absorb and reradiate heat
- Kyoto Protocol establishes 7 priority GHGs (3 applicable to WWTFs)
  - » Global Warming Potentials (GWPs) relate gases on a mass basis

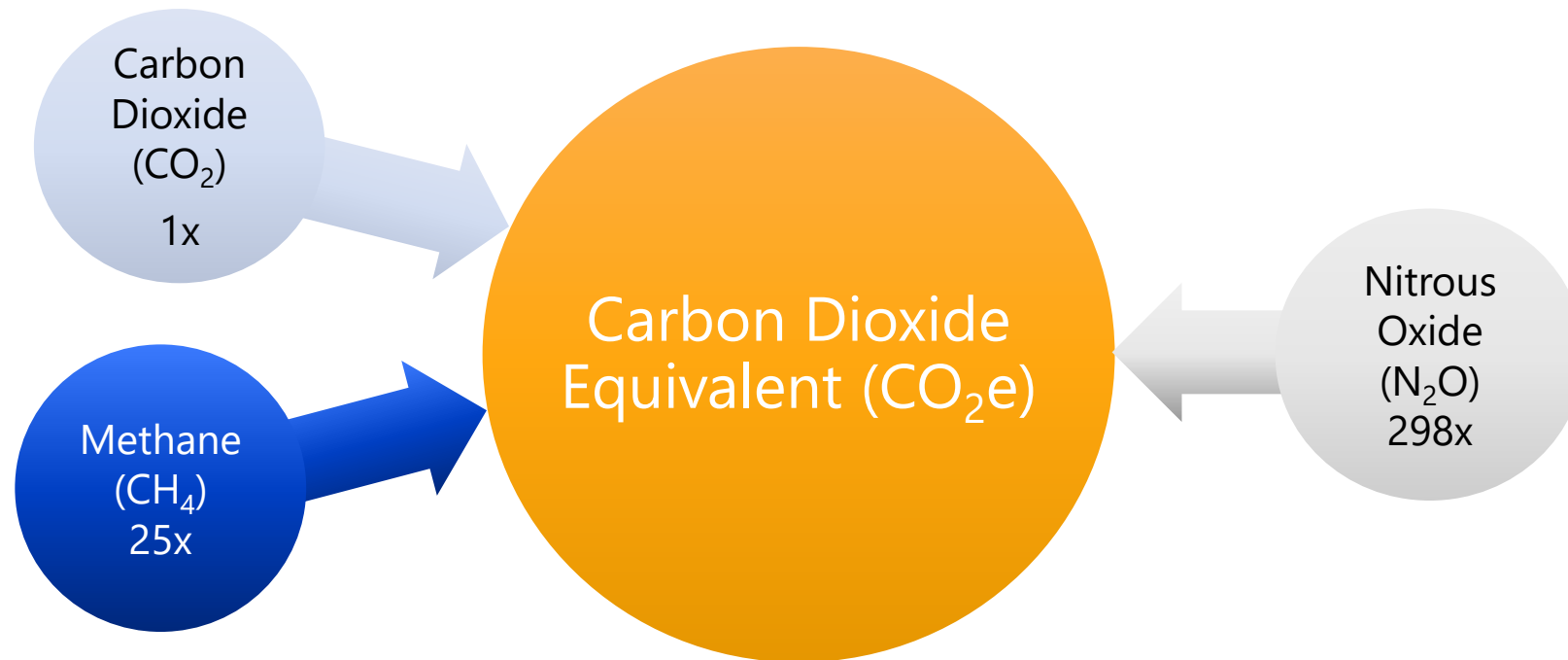

# What is a GHG inventory?

Mass and energy balance model that estimates GHG emissions originating from water or wastewater treatment processes.

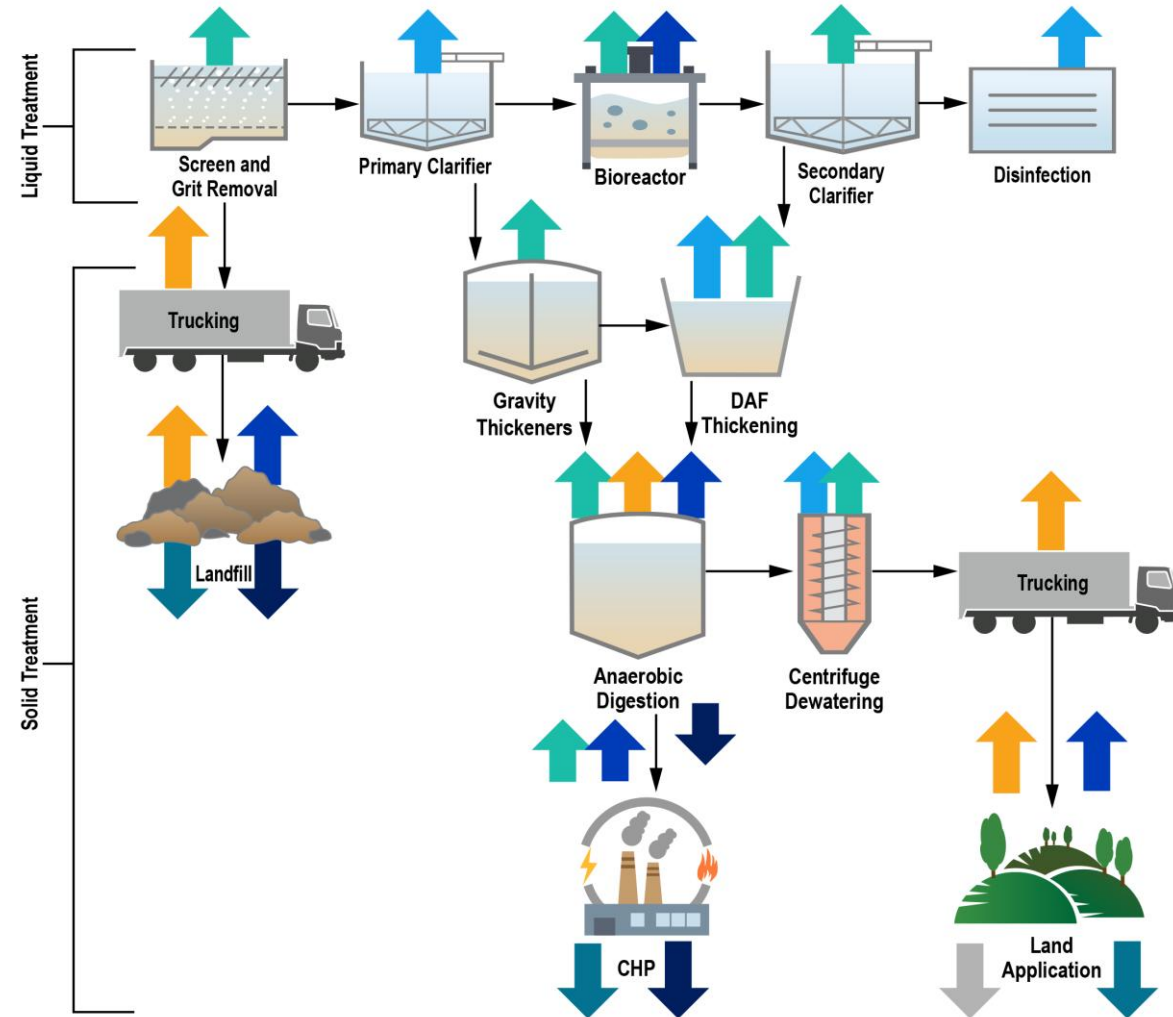
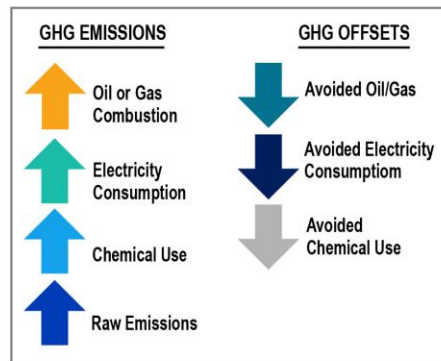

# Why invest in a GHG inventory?

- Quantify emissions for regulatory purposes
- Establish a baseline for future improvements
- Address sustainability goals
- Support innovation initiatives
- Holistic understanding of project impacts



02

Background

# Wastewater Treatment and Resource Recovery Facility (WTRRF)

- Overall
  - » Advanced secondary treatment
  - » Average flow: 9.8 mgd
  - » Peak flow: 50 mgd
  - » High-strength waste receiving
- Biogas
  - » Past:
    - Biogas conditioning
    - Cogeneration
  - » Future:
    - Biogas upgrading
    - Pipeline injection



# Renewable fuel standard program



- Managed by the EPA and used to offset carbon emissions in the transportation sector
- Renewable fuel obligations for fossil fuel producers and refiners

	8-Year Average	Minimum Value	Maximum Value
D3 RIN Price	\$2.08	\$0.46	\$3.50
D5 RIN Price	\$0.87	\$0.28	\$2.04

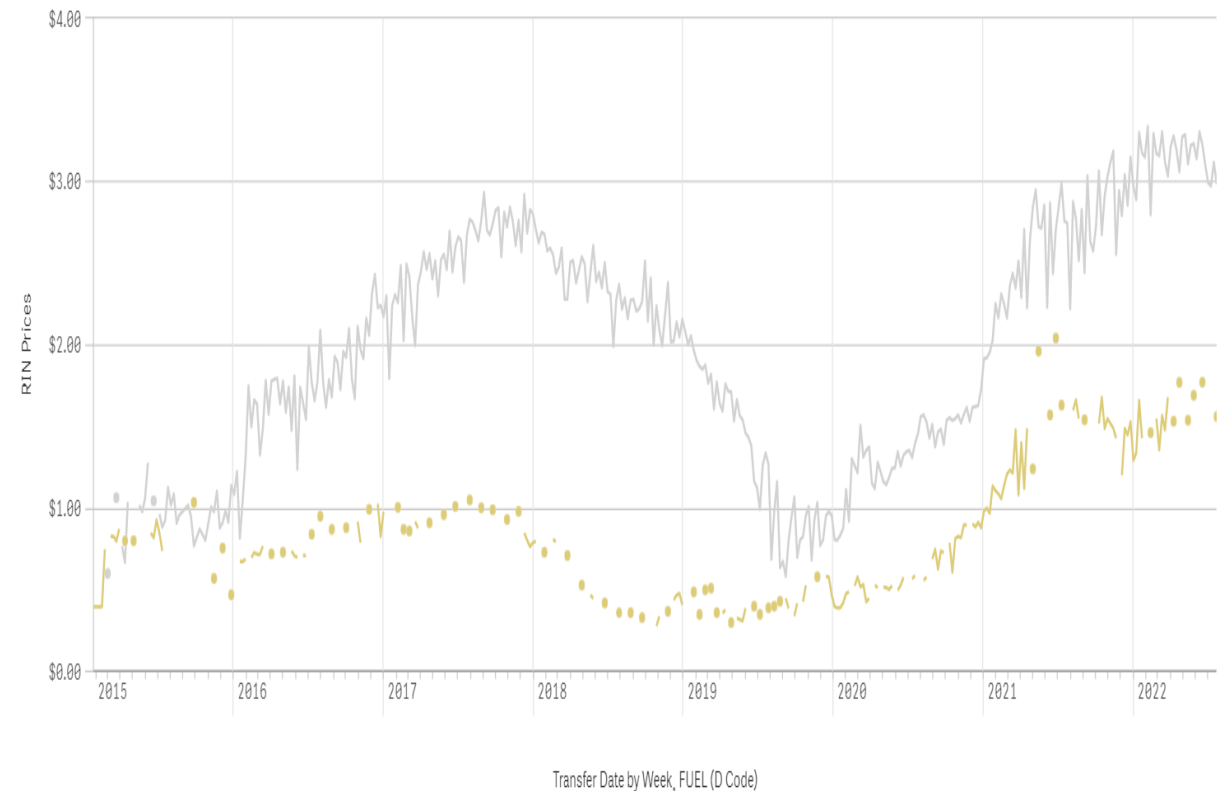

# Summary of revenue sources

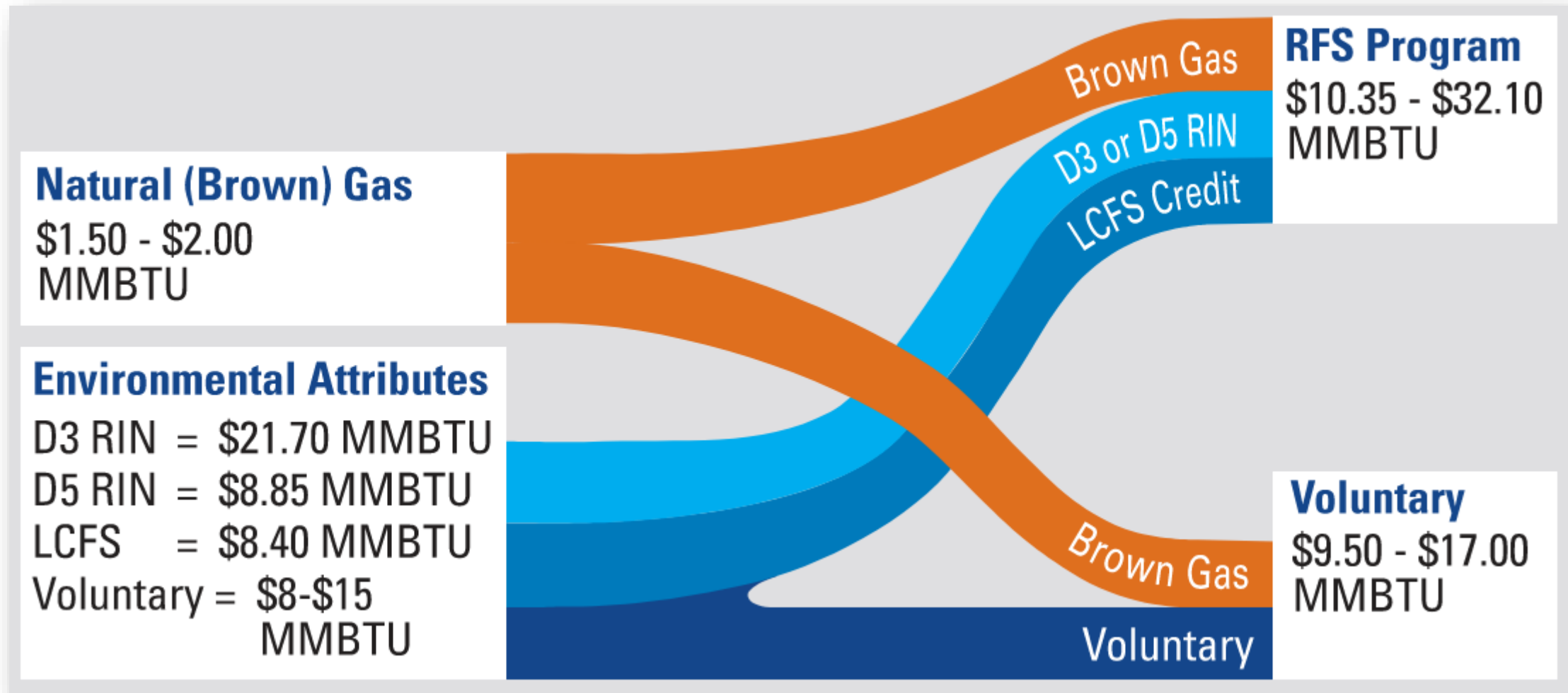

—  
What is RNG?

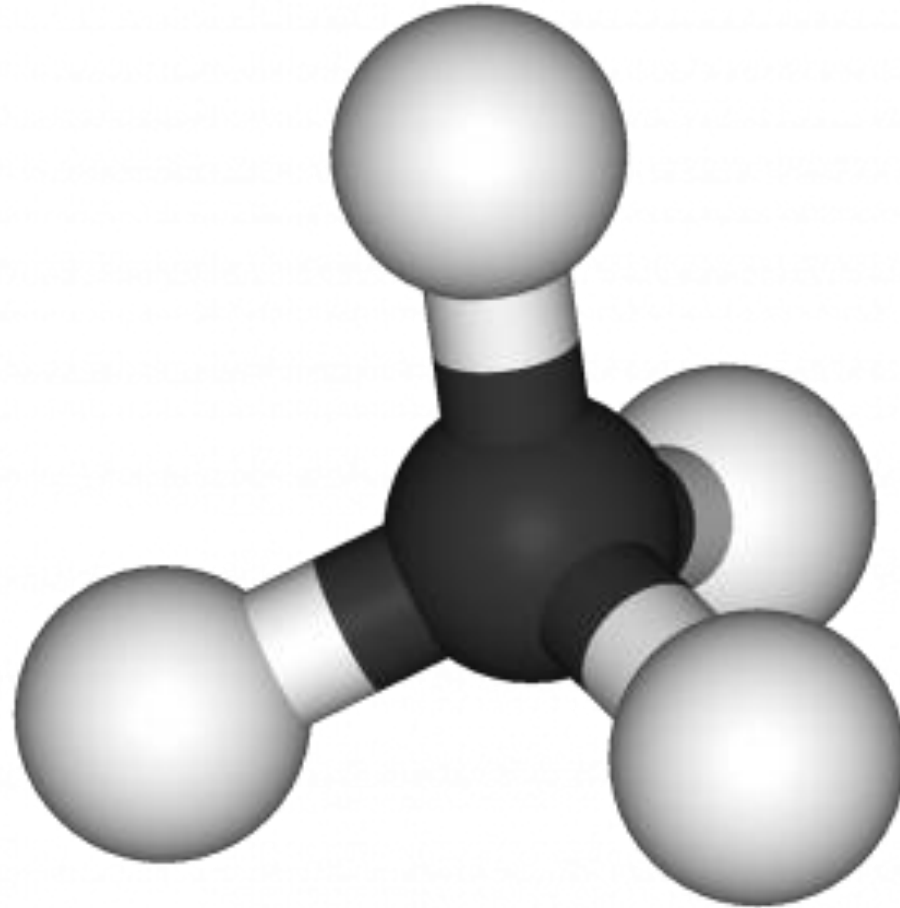

# Biogas upgrading technologies

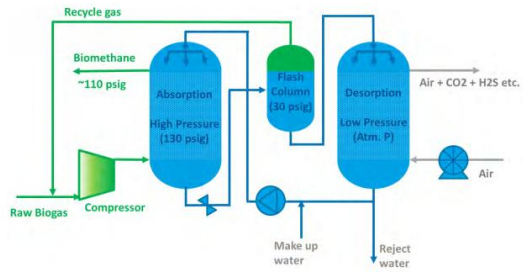

Water Wash

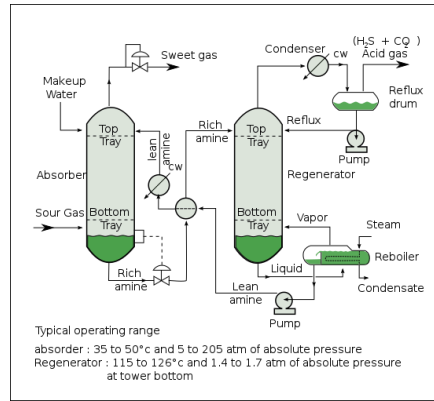

Amine Scrubbing

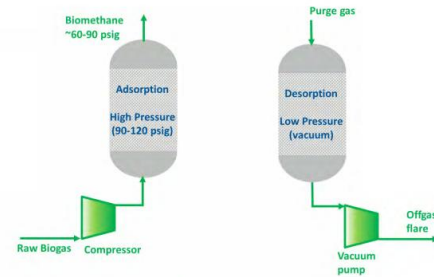

Pressure Swing Adsorption

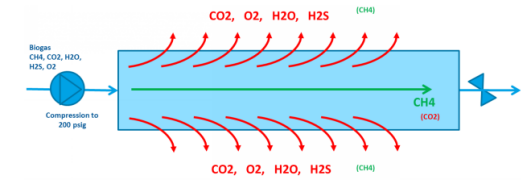

Membrane Separation

# Renewable natural gas

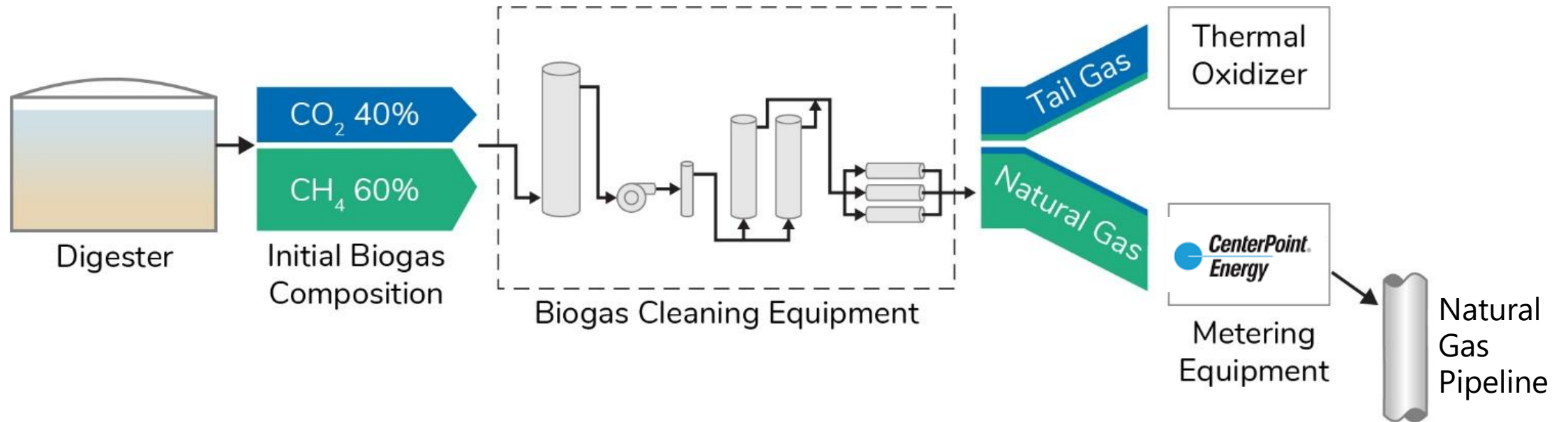

03

## Project Drivers

# Fond du Lac drivers

*Environmental Stewardship*



*Understand Changes*



*Baseline Establishment*



# Wisconsin drivers

- Wisconsin Clean Energy Plan (2022)
  - » “Accelerate clean energy ... deployment”
  - » “Innovate transportation”
  - » 100% carbon free electricity by 2050
- State reporting required at 100,000 short tons CO<sub>2</sub>e per year
- Alliant Energy’s Environmental Stewardship Goals:
  - » 2040: eliminate all coal from our generation fleet.
  - » 2050: aspire to achieve net-zero greenhouse gas emissions from our utility operations.

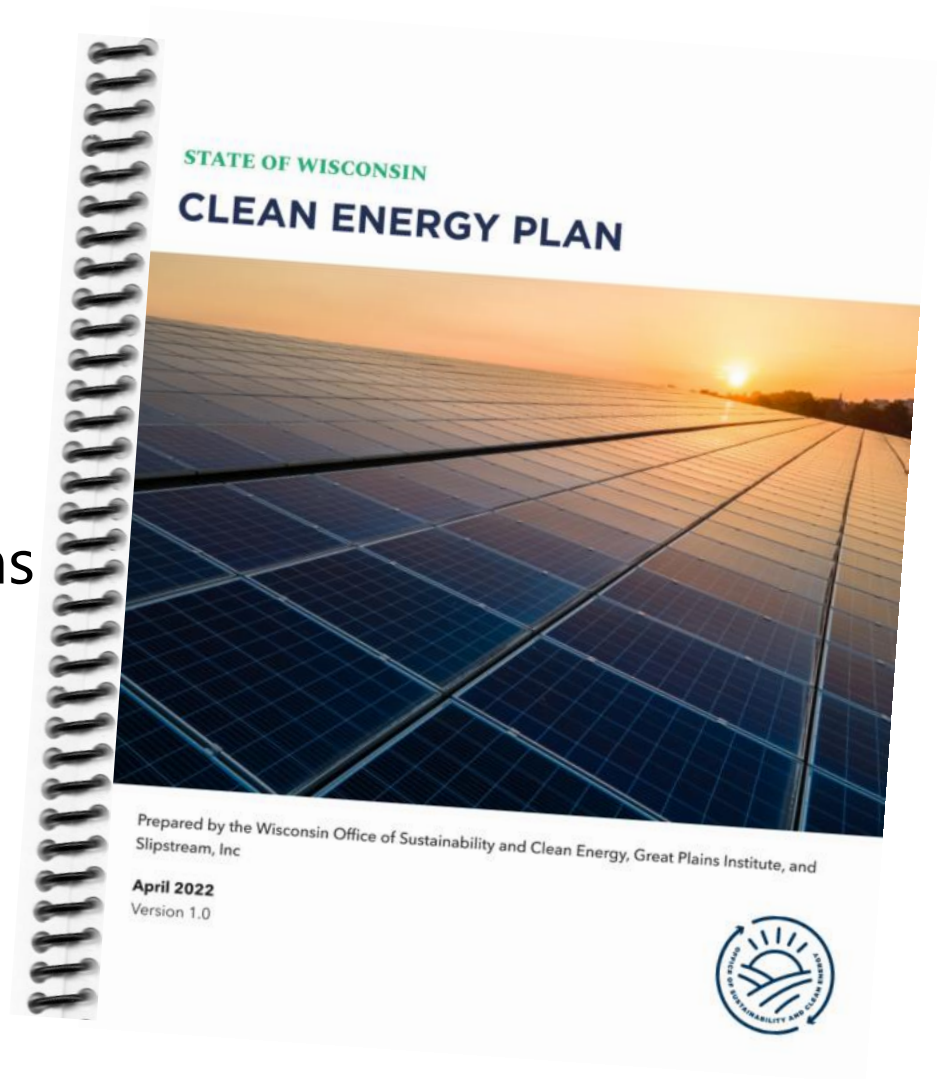

04

# The GHG Inventory Tool

# What's important to get right setting up the tool?

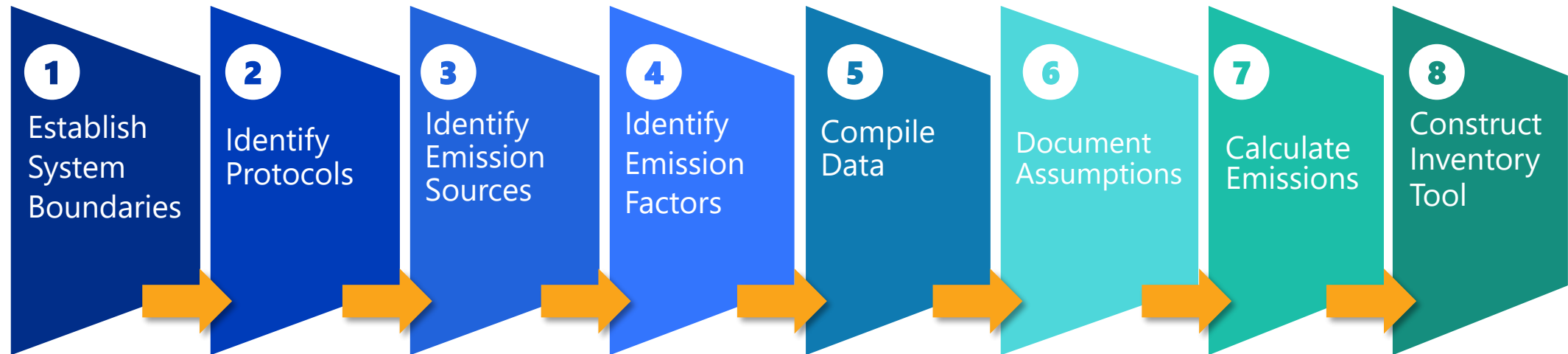

# To fully account for a facility's emissions, the system boundary is critical

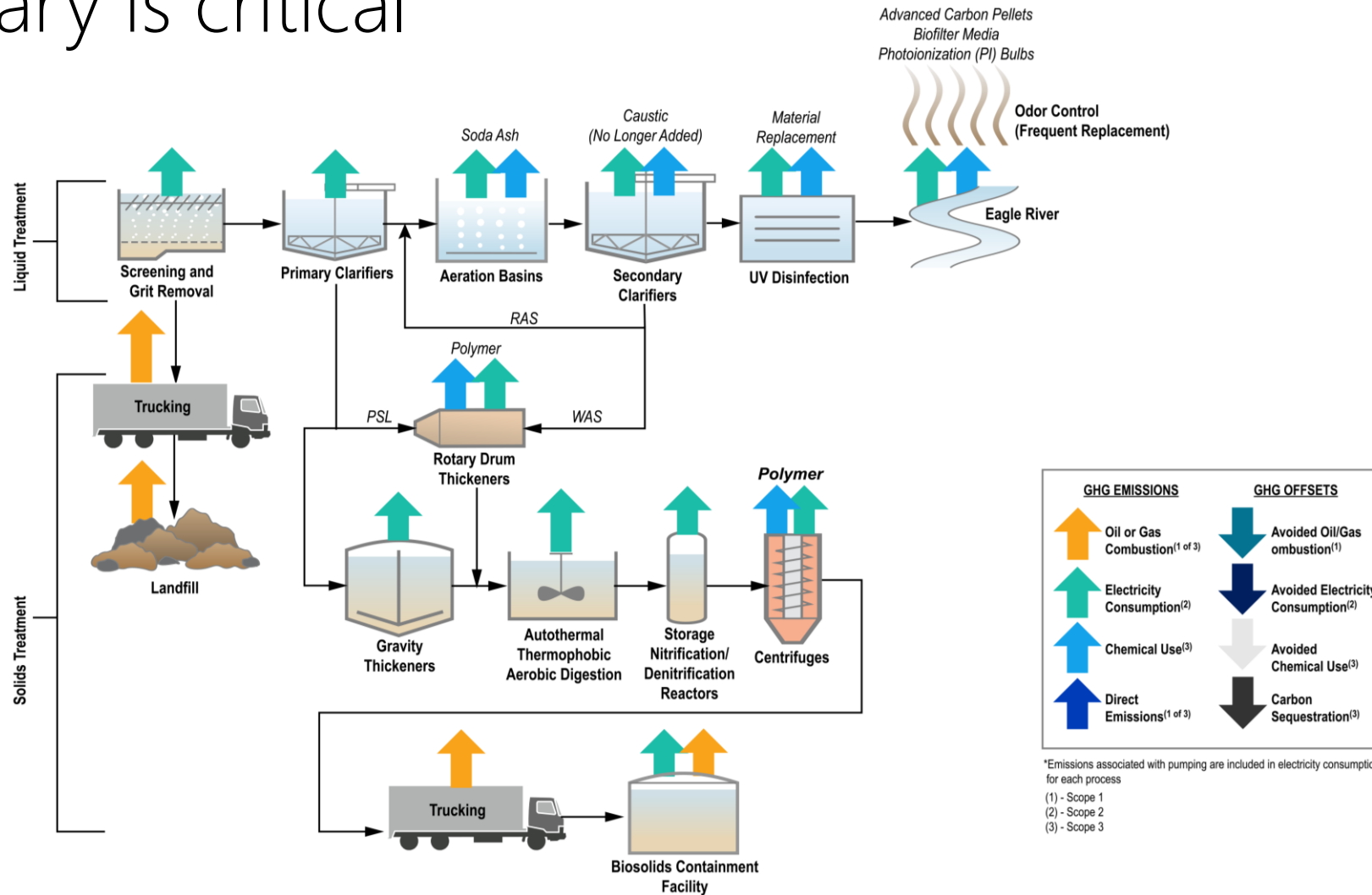

“System Boundary” should reflect typical operating conditions (e.g. a calendar year that represents typical operations)

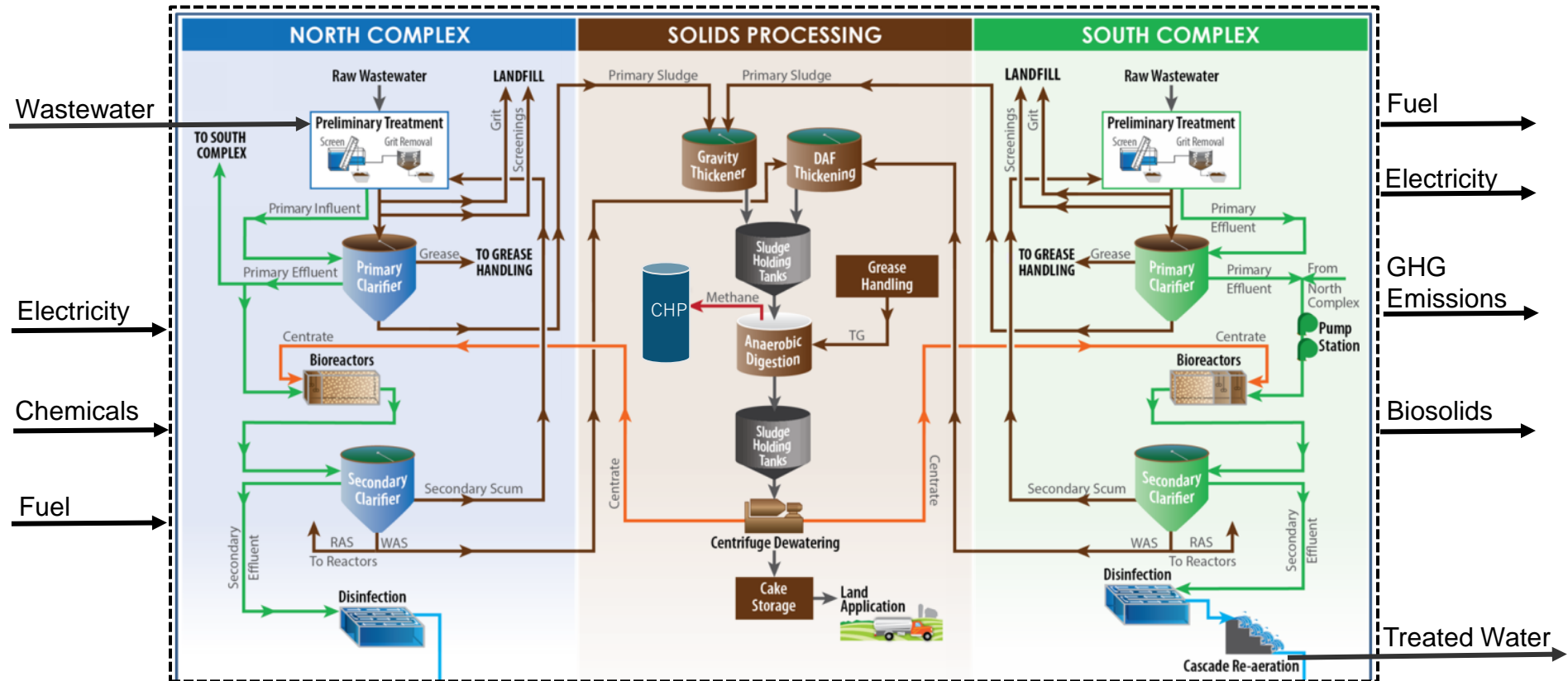

# Fond du Lac WTRRF system boundaries

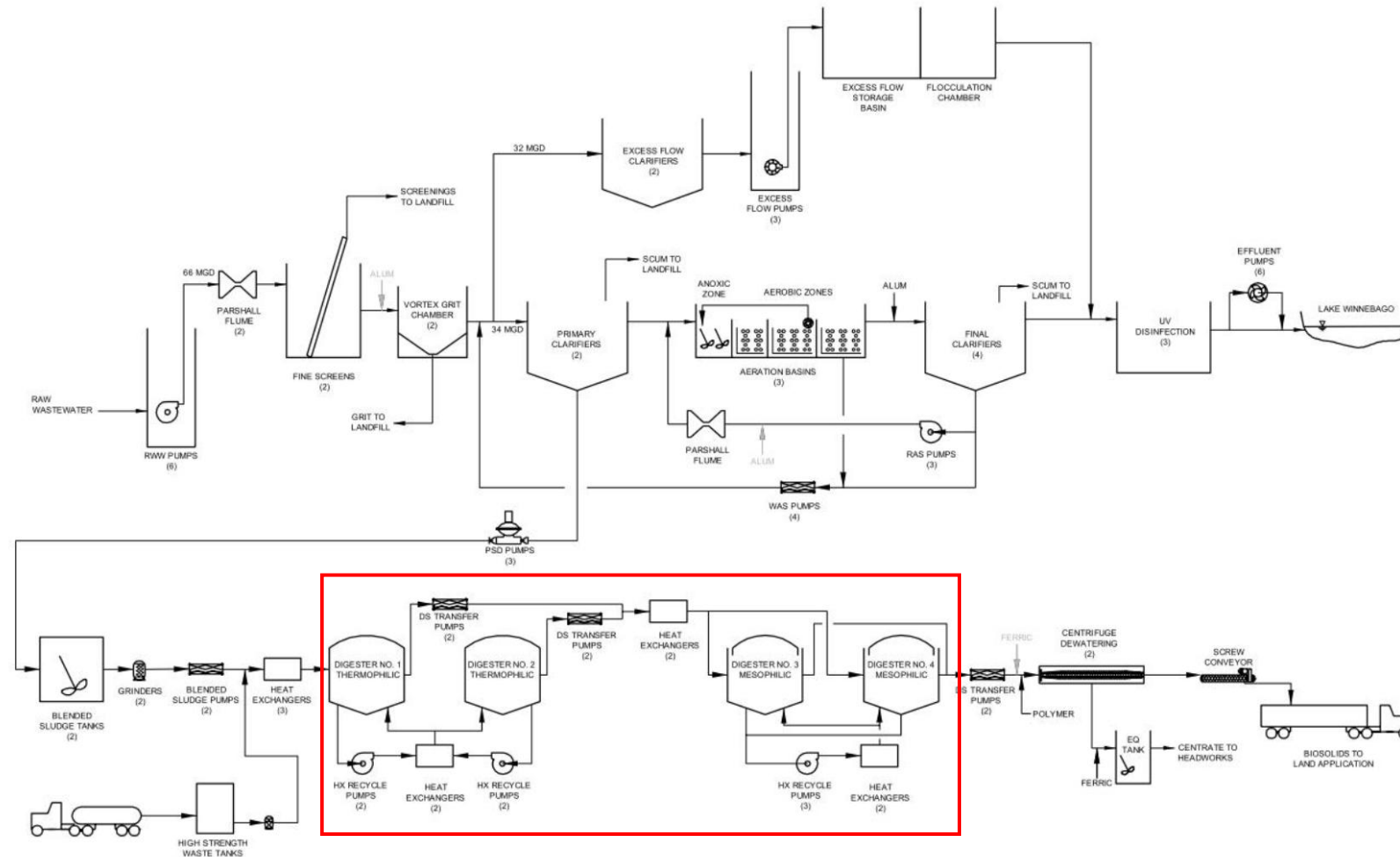

# Cogeneration system boundary/emissions diagram

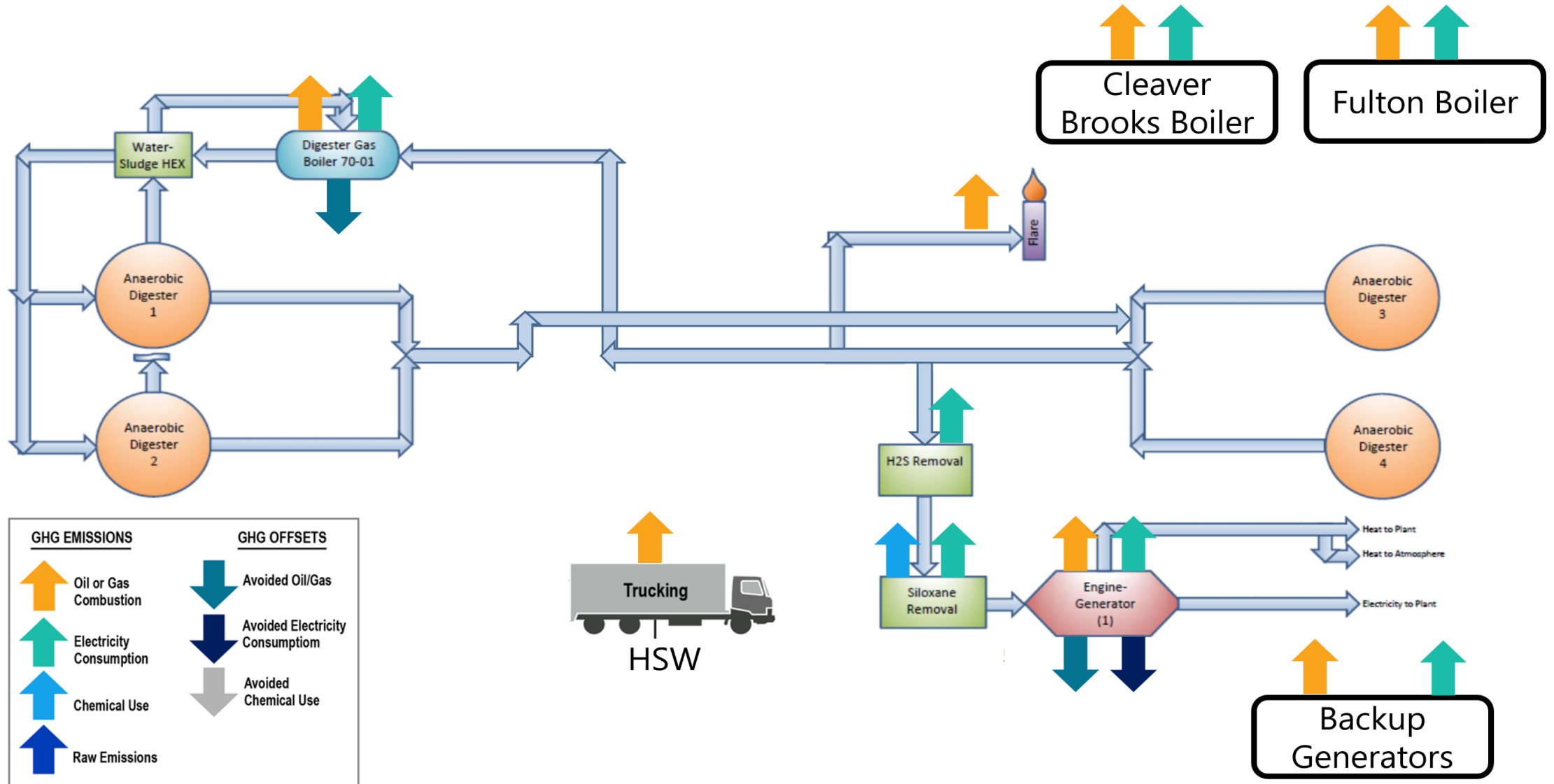

# Biogas upgrading system boundary/emissions diagram

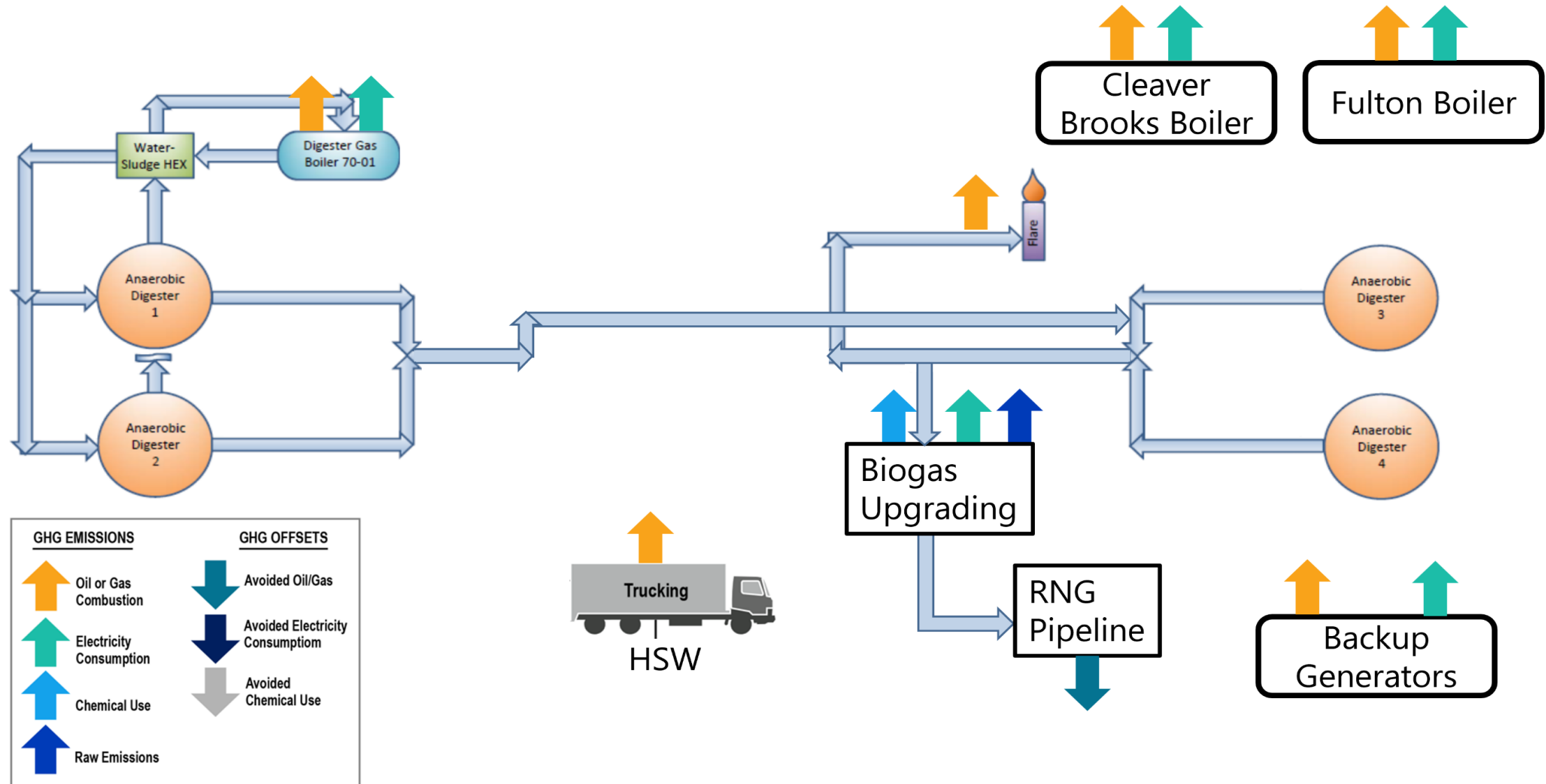

# Impact of offsets on net GHG emissions

- Renewable energy generation
- Beneficial biosolids reuse
- Offset purchasing programs

Fond du Lac's biogas upgrading equipment



# Identify protocols and emission factors



United Nations  
Climate Change

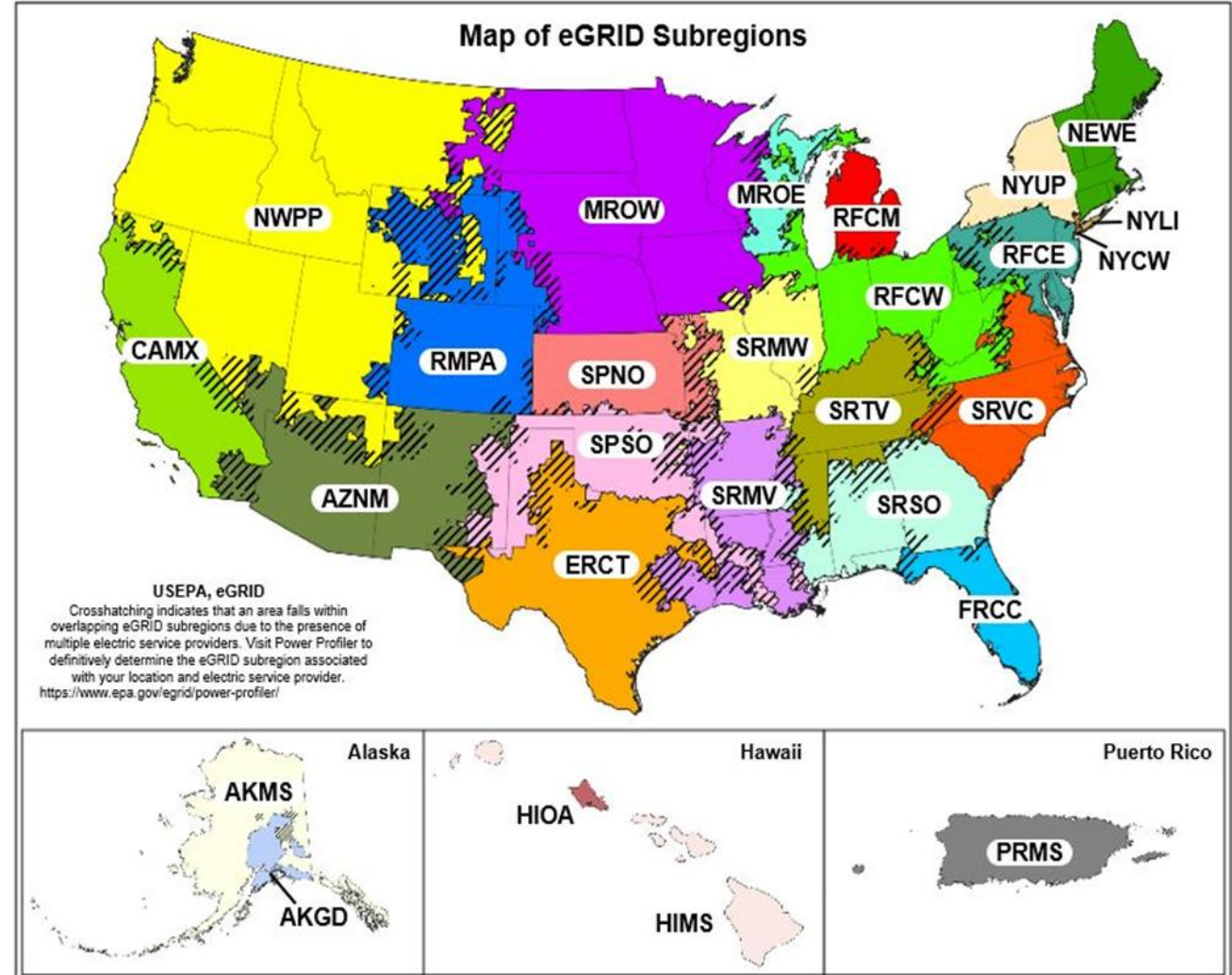
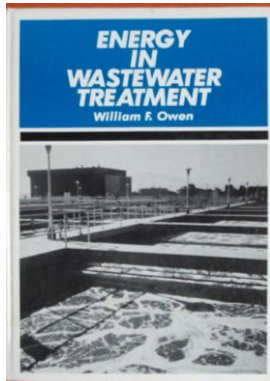

# Inventory tool: calculations

## DIRECT (Scope 1) EMISSIONS

CO <sub>2</sub> -Equivalent Emissions Generated from Natural Gas Combustion for Building Heat, Heat Gen, and Other Uses						
	Natural Gas Consumption (scf)	Carbon Dioxide (kg CO <sub>2</sub> /yr)	Methane (kg CH <sub>4</sub> /yr)	Nitrous Oxide (kg N <sub>2</sub> O/yr)	kg CO <sub>2</sub> e per year	Metric Tons CO <sub>2</sub> e per Year
Baseline: 2019	8,121,857	445,598	8.4	0.84	446,058	446
Future Scenario: Year	8,121,857	445,598	8.4	0.84	446,058	446

CO <sub>2</sub> -Equivalent Emissions Generated from Centralized WWTF with Nitrification/Denitrification				
	Influent TKN (mg/L)	Nitrous Oxide (g N <sub>2</sub> O/yr)	kg CO <sub>2</sub> e per year	Metric Tons CO <sub>2</sub> e per Year
Baseline: 2019	68	816,088	243,194	243
Future Scenario: Year	68	816,088	243,194	243

## INDIRECT (Scopes 2 & 3) EMISSIONS

CO <sub>2</sub> -Equivalent Emissions Resulting from Electricity Consumption for Operation of the Treatment Facility and Other Uses						
	Annual Electricity Consumption (kWh)	Multiply by Emission Factor, kg CO <sub>2</sub> e			CO <sub>2</sub> e Emissions per Year	
		Carbon Dioxide	Methane	Nitrous Oxide	kg CO <sub>2</sub> e	Metric Tons CO <sub>2</sub> e
Baseline: 2019	5,068,056	2,523,892	6,474	11,327	2,541,693	2,542
Future Scenario: Year	5,068,056	2,523,892	6,474	11,327	2,541,693	2,542

05

Findings

# GHG inventory findings

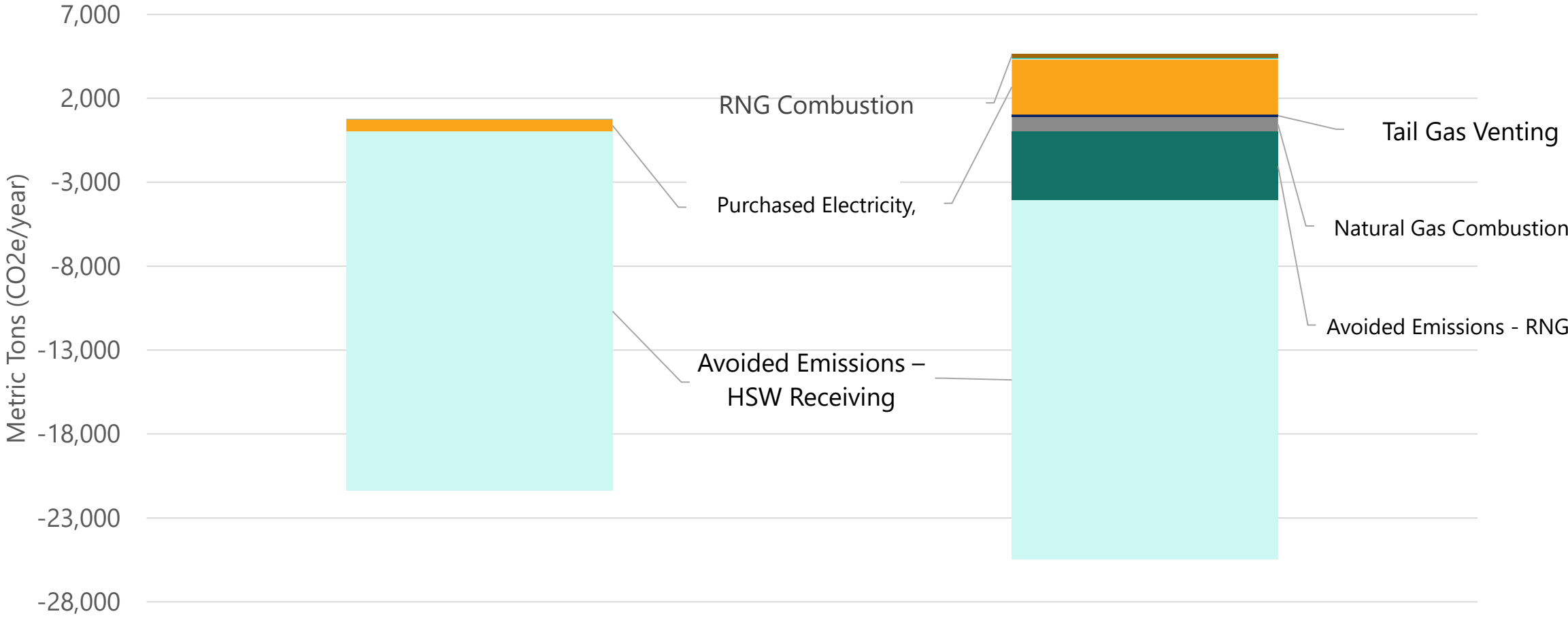

# GHG inventory findings

- Purchased electricity - 70%
  - » Removal of cogeneration
  - » Biogas upgrading
- Natural gas combustion (heating) - 20%
  - » Removal of cogeneration
- Consumables – 2%
- CNG combustion: 5%
- Tail gas – 3%
- Combustion: flare, boilers, cogen
  - » CO<sub>2</sub> considered biogenic
- Note: high strength waste not shown, no change between alternatives.
  - » *Offsets equal 400% of emissions*

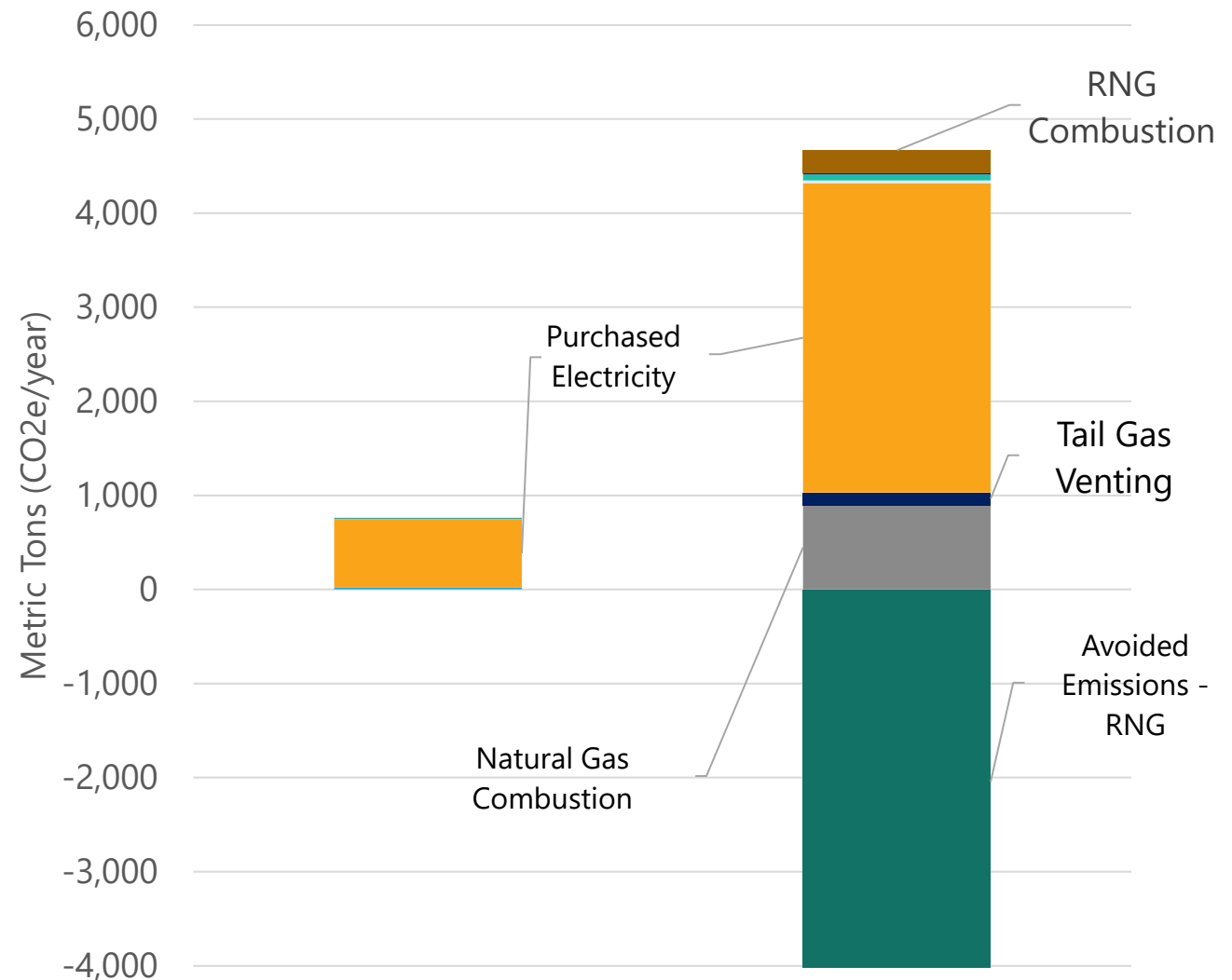

06

Takeaways

# Takeaways

