



1974-78 Datsun 260/280Z

Gen 5 Evaporator Kit
(589026)



18865 Goll St. San Antonio, TX 78266
Phone: 800-862-6658
Sales: sales@vintageair.com
Tech Support: tech@vintageair.com
www.vintageair.com



www.vintageair.com

Table of Contents

Cover.....	1
Table of Contents.....	2
Packing List/Parts Disclaimer.....	3
Information Page.....	4
Wiring Notice.....	5
Engine Compartment Disassembly, Condenser Assembly and Installation, Compressor and Brackets.....	6
OEM A/C System Engine Compartment Disassembly.....	7
Center Console Disassembly and Removal.....	8
Dash Overview & Exterior Disassembly.....	9
Underdash Exploded Overview, Dash Accessories Disassembly.....	10-11
Climate Control Unit Disassembly and Removal.....	12
Evaporator & Heater Core Removal.....	13-15
Firewall Modification and Fresh Air Cap Installation.....	16-17
Wiring Harness Installation.....	18
Junction Block Relocation & Bracket Installation.....	19
Junction Block Relocation & Bracket Installation (Cont.), Heater Ports Cover Plate Installation.....	20
Firewall Preparation and Heater Hose Installation, Defrost Duct & Dash Vent Adapters Installation.....	21-22
Center Louver Housing Adapter Installation, Lubricating O-rings & Fitting Torque Specs.....	23
Properly Seated O-ring Land, Evaporator Preparation & Installation.....	24
Evaporator Preparation & Installation (Cont.).....	25-28
Drain Hose and Grommet Installation.....	29-30
Heater Control Valve Installation.....	31
A/C Hose Installation.....	32-34
Wiring.....	35
Fast Idle Control (A/C Idle-Up).....	36
FICD Vacuum & Wiring Diagram.....	37
Engine Compartment Wiring.....	38-39
Final Steps: Installation Check.....	40
Final Steps: Completing the Install.....	41
Duct Hose Routing.....	42
Glove Box Installation.....	43
Quality Crimp Guideline.....	44
Gen 5 Wiring Diagram.....	45
Gen 5 Wiring Connection Instruction.....	46
Operation of Controls.....	47
Troubleshooting Guide.....	48
Troubleshooting Guide (Cont.), Advanced Diagnostics and Troubleshooting Guide.....	49
Packing List.....	50



www.vintageair.com

Packing List: Evaporator Kit (589026)

No.	Qty.	Part No.	Description
1.	1	765200	Gen 5 Magnum Max Module with 404 ECU
2.	1	789026	Accessory Kit

**** Before beginning installation, open all packages and check contents of shipment. Please report any shortages directly to Vintage Air within 15 days. After 15 days, Vintage Air will not be responsible for missing or damaged items.**

1



Gen 5 Magnum Max
Module with 404 ECU
765200

2

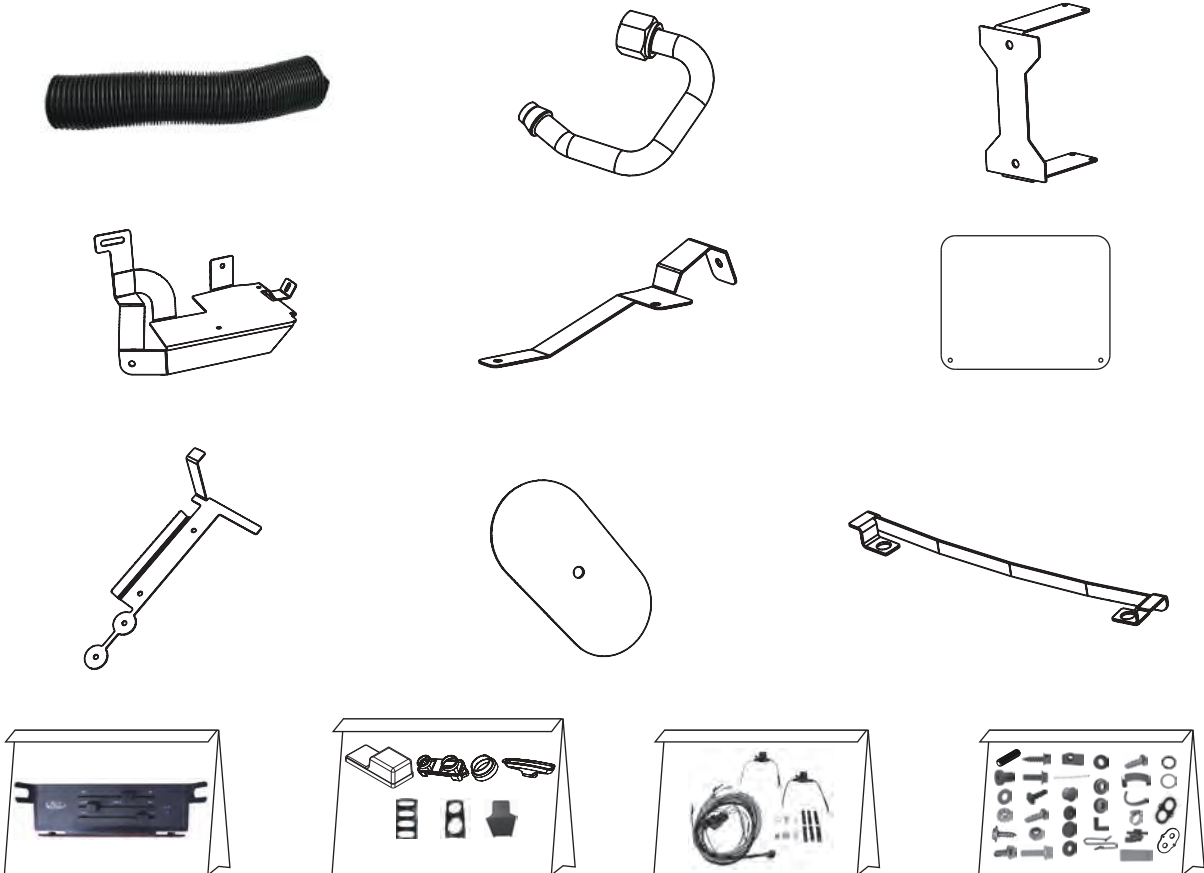

Accessory Kit
789026

NOTE: Images may not depict actual parts and quantities. Refer to packing list for actual parts and quantities.



www.vintageair.com

Important Notice—Please Read

For Maximum System Performance, Vintage Air Recommends the Following:

NOTE: Vintage Air systems are designed to operate with R134a refrigerant only. Use of any other refrigerant could damage your A/C system and/or vehicle, and possibly cause a fire, in addition to potentially voiding the warranties of the A/C system and its components.

Refrigerant Capacities:

Vintage Air System: 1.8 lbs. (28.8 oz.) or 816 grams of **R134a**, charged by weight with a quality charging station or scale. **NOTE: Use of the proper type and amount of refrigerant is critical to system operation and performance.**

Other Systems: Consult manufacturer's guidelines.

Lubricant Capacities:

New Vintage Air-Supplied Sanden Compressor: No additional oil needed (Compressor is shipped with proper oil charge).

All Other Compressors: Consult manufacturer (Some compressors are shipped dry and will need oil added).

Safety Switches

Your Vintage Air system is equipped with a binary pressure safety switch. A binary switch disengages the compressor clutch in cases of extreme low pressure conditions (refrigerant loss) or excessively high head pressure (406 PSI) to prevent compressor damage or hose rupture. A trinary switch combines Hi/Lo pressure protection with an electric fan operation signal at 254 PSI, and should be substituted for use with electric fans. Compressor safety switches are extremely important since an A/C system relies on refrigerant to circulate lubricant.

Service Info:

Protect Your Investment: Prior to assembly, it is critical that the compressor, evaporator, A/C hoses and fittings, hardlines, condenser and receiver/drier remain capped. Removing caps prior to assembly will allow moisture, insects and debris into the components, possibly leading to reduced performance and/or premature failure of your A/C system. This is especially important with the receiver/drier.

Additionally, when caps are removed for assembly, **BE CAREFUL!** Some components are shipped under pressure with dry nitrogen.

Evacuate the System for 35-45 Minutes: Ensure that system components (Drier, compressor, evaporator and condenser) are at a temperature of at least 85°F. On a cool day, the components can be heated with a heat gun **or** by running the engine with the heater on before evacuating. Leak check and charge to specifications.

Bolts Passing Through Cowl and/or Firewall:

To ensure a watertight seal between the passenger compartment and the vehicle exterior, for all bolts passing through the cowl and/or firewall, Vintage Air recommends coating the threads with silicone prior to installation.

Heater Hose (not included with this kit):

Heater hose may be purchased from Vintage Air (Part#31800-VUD) or your local parts retailer. Routing and required length will vary based on installer preference.



www.vintageair.com

Important Wiring Notice—Please Read

Some vehicles may have had some or all of their radio interference capacitors removed. There should be a capacitor found at each of the following locations:

- 1. On the positive terminal of the ignition coil.**
- 2. If there is a generator, on the armature terminal of the generator.**
- 3. If there is a generator, on the battery terminal of the voltage regulator.**

Most alternators have a capacitor installed internally to eliminate what is called “whining” as the engine is revved. If whining is heard in the radio, or just to be extra cautious, a radio interference capacitor can be added to the battery terminal of the alternator.

It is also important that the battery lead is in good shape and that the ground leads are not compromised. There should be a heavy ground from the battery to the engine block, and additional grounds to the body and chassis.

If these precautions are not observed, it is possible for voltage spikes to be present on the battery leads. These spikes come from ignition systems and charging systems, and from switching some of the vehicle’s other systems on and off. Modern computer-operated equipment can be sensitive to voltage spikes on the power leads, which can cause unexpected resets, strange behavior and/or permanent damage.

Vintage Air strives to harden our products against these types of electrical noise, but there is a point where a vehicle’s electrical system can be degraded so much that nothing can help.

Radio interference capacitors should be available at most auto and truck parts suppliers. They typically are cylindrical in shape, a little over an inch long and a little over a half-inch in diameter, and they have a single lead coming from one end of the cylinder with a terminal on the end of the wire, as well as a mounting clip which is screwed into a good ground on the vehicle. The specific value of the capacitance is not too significant in comparison to ignition capacitors that are matched with the coil to reduce pitting of the points.

- Care must be taken, when installing the compressor lead, not to short it to ground. The compressor lead must not be connected to a condenser fan or to any other auxiliary device. Shorting to ground or connecting to a condenser fan or any other auxiliary device may damage wiring or the compressor relay, and/or cause a malfunction.
- When installing ground leads on Gen 5 systems, the blower control ground and ECU ground must be connected directly to the negative battery post.
- For proper system operation, the heater control valve must be connected to the ECU.



www.vintageair.com

Engine Compartment Disassembly

NOTE: Before starting the installation, check the function of the vehicle (horn, lights, etc.) for proper operation, study the instructions, illustrations, photos & diagrams. Removing the vehicle's hood is not absolutely necessary to achieve full kit install, but can ease accessibility to the front core support components.

Perform the following:

1. Disconnect the negative and positive battery post cables from the vehicle's battery.
2. Drain coolant from the radiator.
3. Disconnect upper and lower radiator hoses from the radiators inlet and outlet ports.
4. Remove radiator fan and shroud.
5. Remove the (4) bolts that secure the radiator against the core support. Carefully remove the radiator from the engine compartment.
6. Disconnect the (2) heater hoses from the heater core ports on the firewall and disconnect the ends to the engine's cylinder head and water pump port

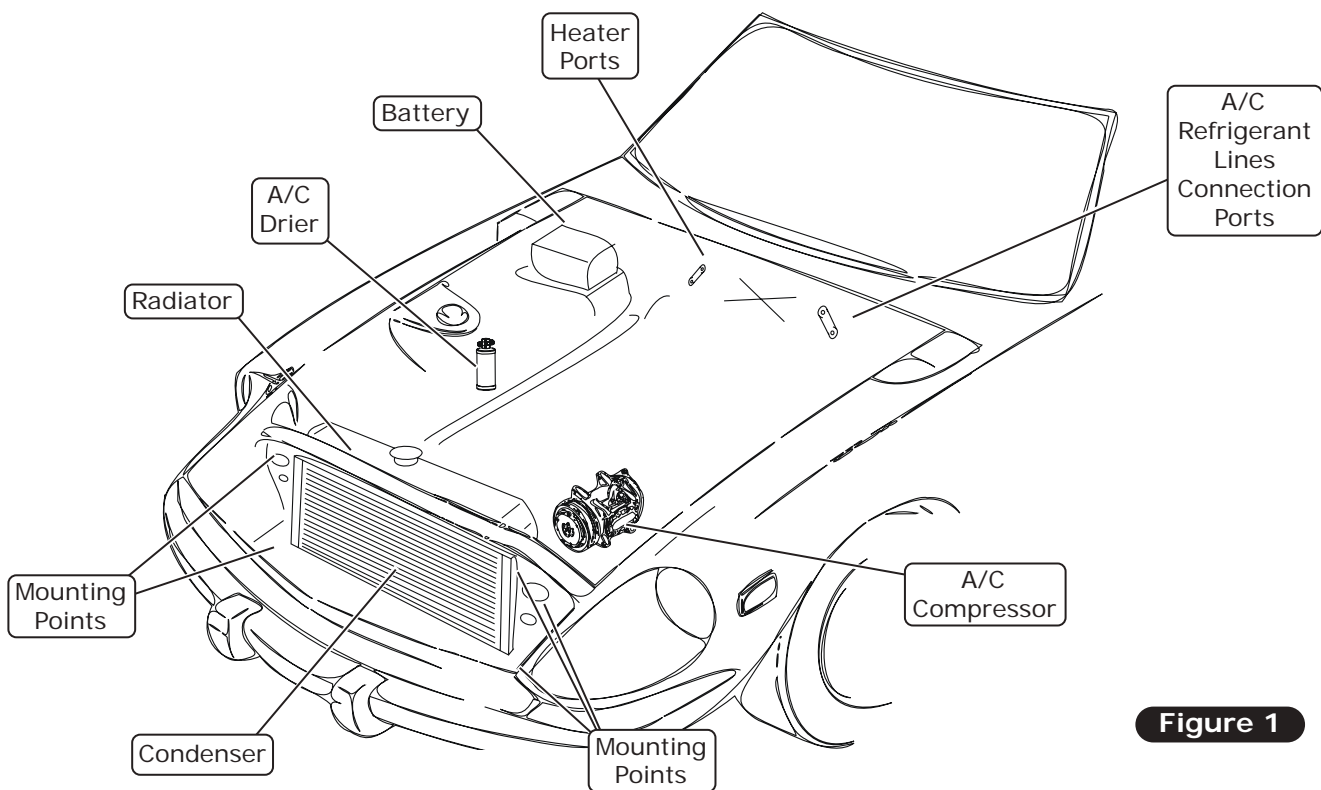

Figure 1

Condenser Assembly and Installation

1. Refer to separate instructions included with the condenser kit to install the condenser.
2. Binary switch installation (Refer to condenser instructions).

Compressor and Brackets

1. Refer to separate instructions included with the bracket kit to install the compressor bracket.



www.vintageair.com

OEM A/C System Engine Compartment Disassembly

NOTE: Before further disassembly, evacuate the A/C system.

Perform the following:

1. Disconnect the single power lead to the compressor and pigtail connector to the driers low/high pressure switch (See Figure 1, below).
2. Remove the following OEM A/C system components; compressor, condenser, drier, low and high pressure hardlines.

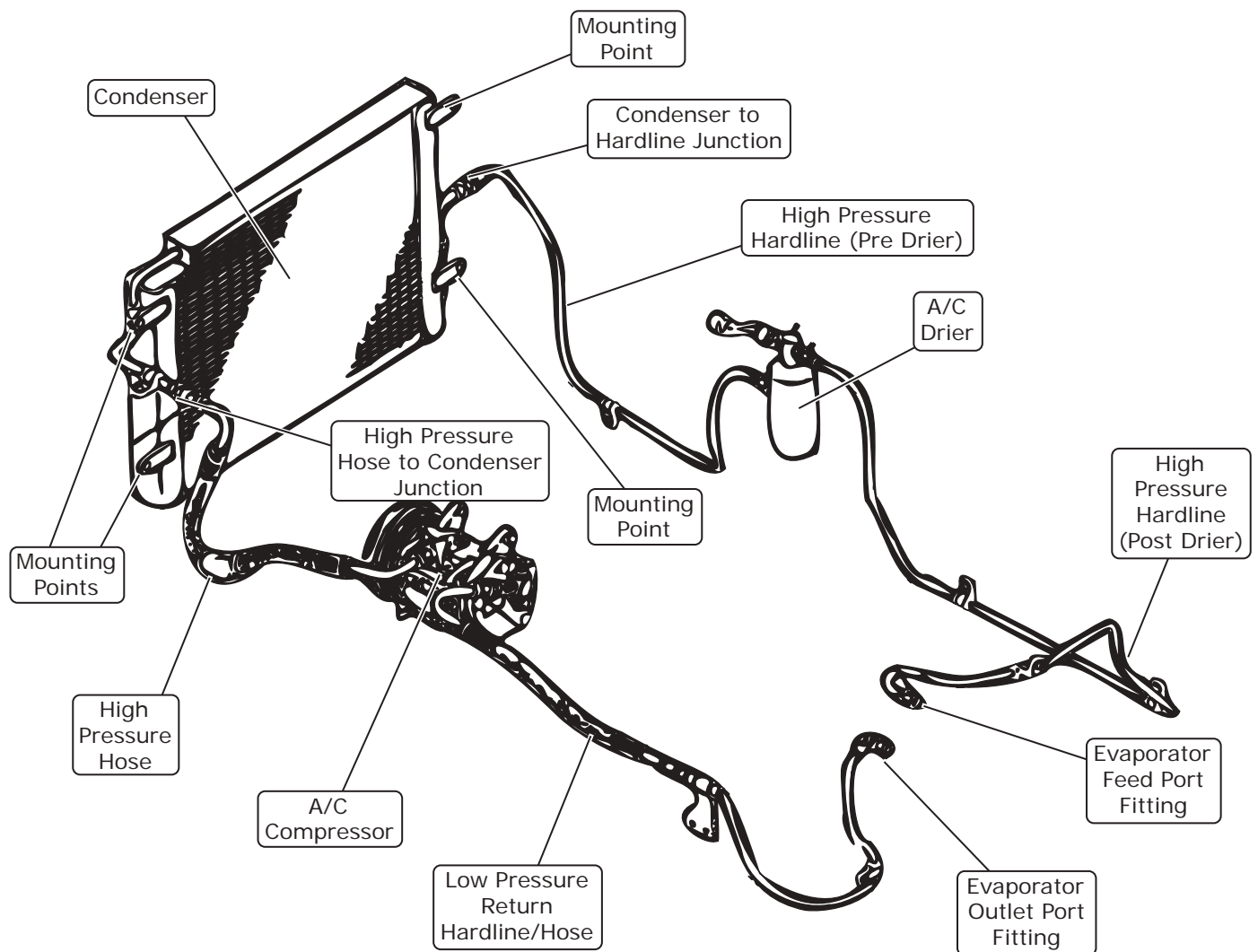

Figure 1



www.vintageair.com

Center Console Disassembly and Removal

1. Remove the radio's (2) adjustment dials and the face panel securing nuts.
2. Remove the (5) securing screws.
3. Remove the shift knob and place the shift lever into either 2nd, 4th, or reverse gear.
4. Carefully lift and disconnect any bulb connectors. Once free, pull back and up to remove the center console. Retain all hardware.

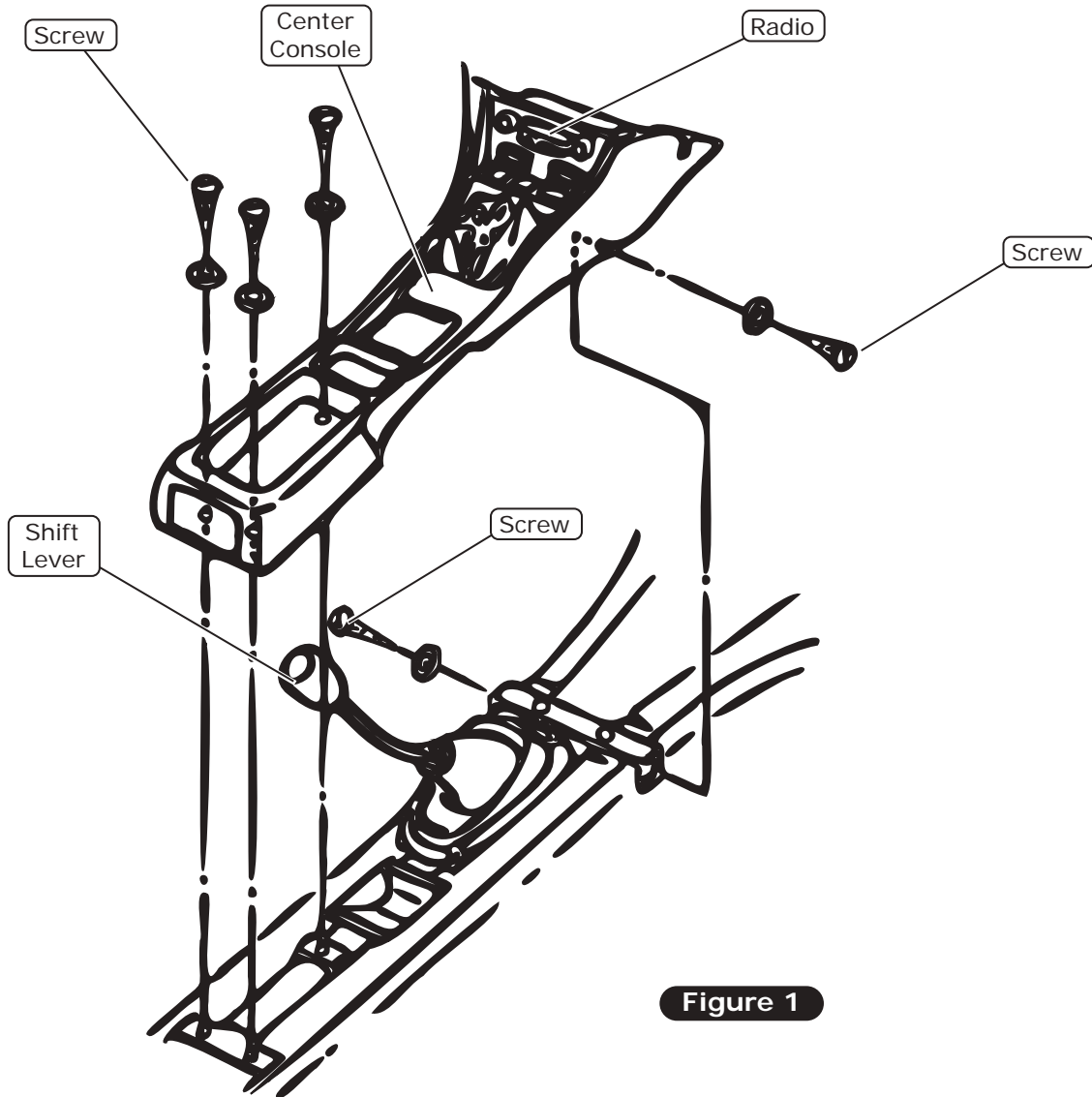

Figure 1



www.vintageair.com

Dash Overview & Exterior Disassembly

NOTE: Retain all components and hardware.

1. Remove the defrost vent cover by removing (4) screws (See Figure 1, below).
2. Remove the under dash passenger panel (if equipped) by removing (2) screws from underside of panel (See Figure 2, below).
3. Remove the lower dash support brackets from the dash and transmission tunnel by removing (4) bolts on each bracket (See Figure 1, below). Temporarily remove brackets and retain hardware.
4. Remove glove box door and glove box.

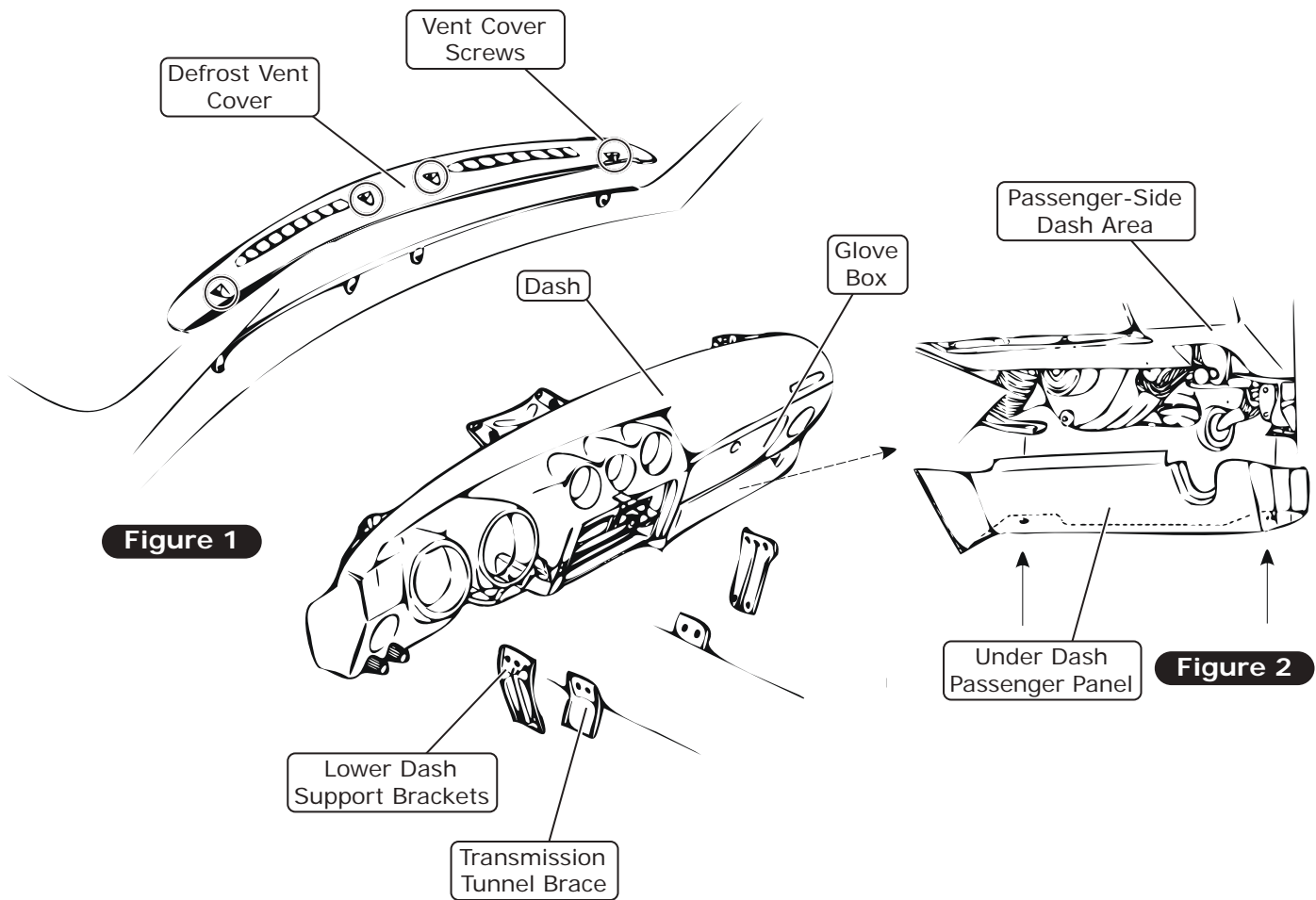



www.vintageair.com

Underdash Exploded Overview

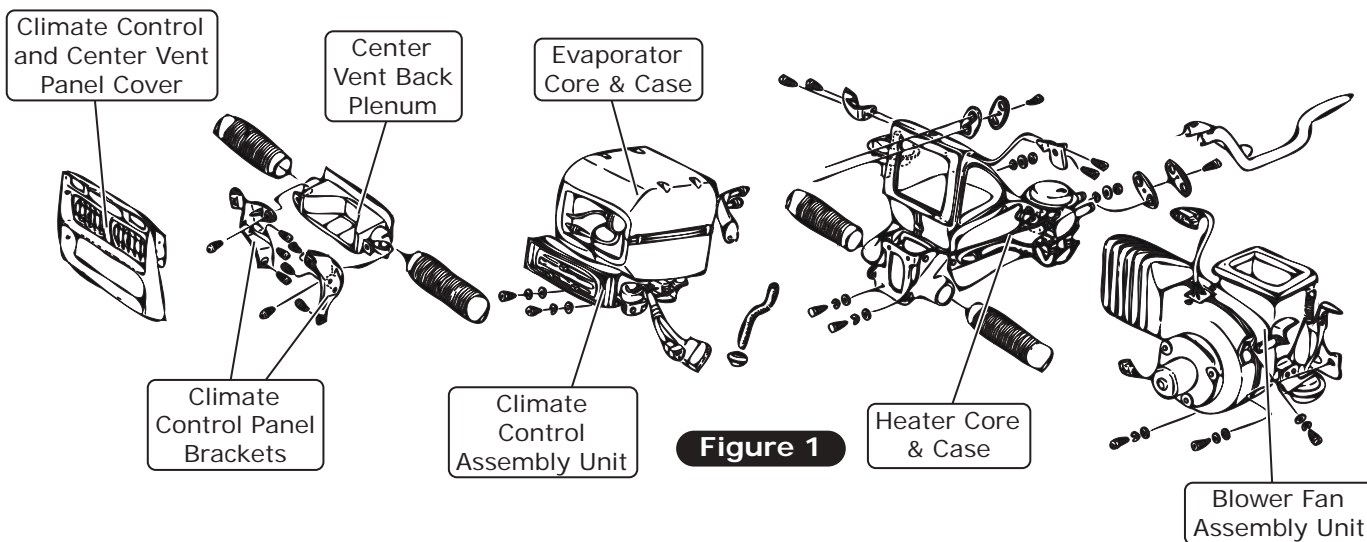

Dash Accessories Disassembly

1. Remove the (4) screws as shown in Figure 1, below. Retain screws.
2. Carefully remove center dash panel, and carefully pull away to expose the (2) rear bulb connectors. Disconnect bulb connectors to free the panel from the dash.

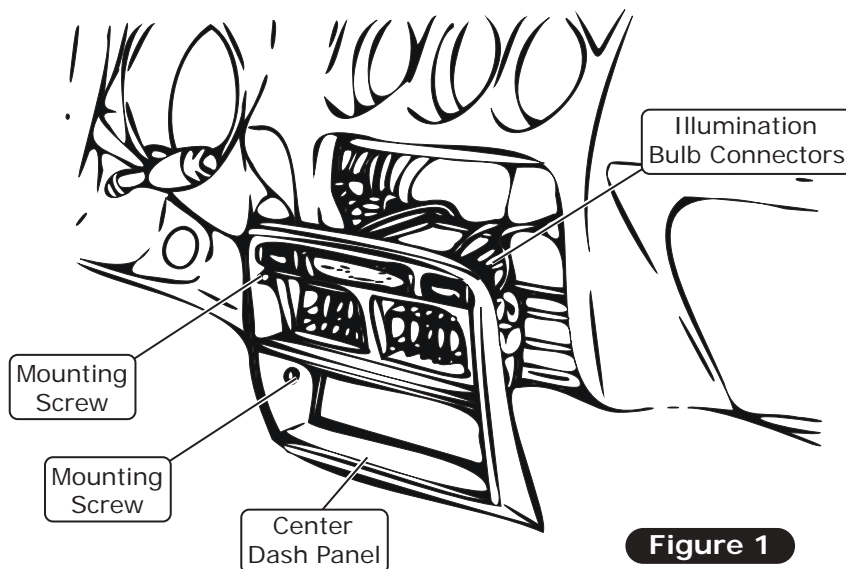



www.vintageair.com

Dash Accessories Disassembly (Cont.)

3. Remove the (2) bolts from the radio's underside (See Figure 2, below). Retain bolts.
4. Disconnect any associated cables and connectors to the radio unit. Once free, remove radio from the center dash support.
5. Remove the single screw supporting the OEM center vent back plenum on each bracket (See Photo 1, below). Discard the OEM center vent back plenum.
6. Temporarily remove the (2) screws for each panel support bracket (See Photo 1, below). Retain screws.
7. Remove brackets for evaporator core accessibility.

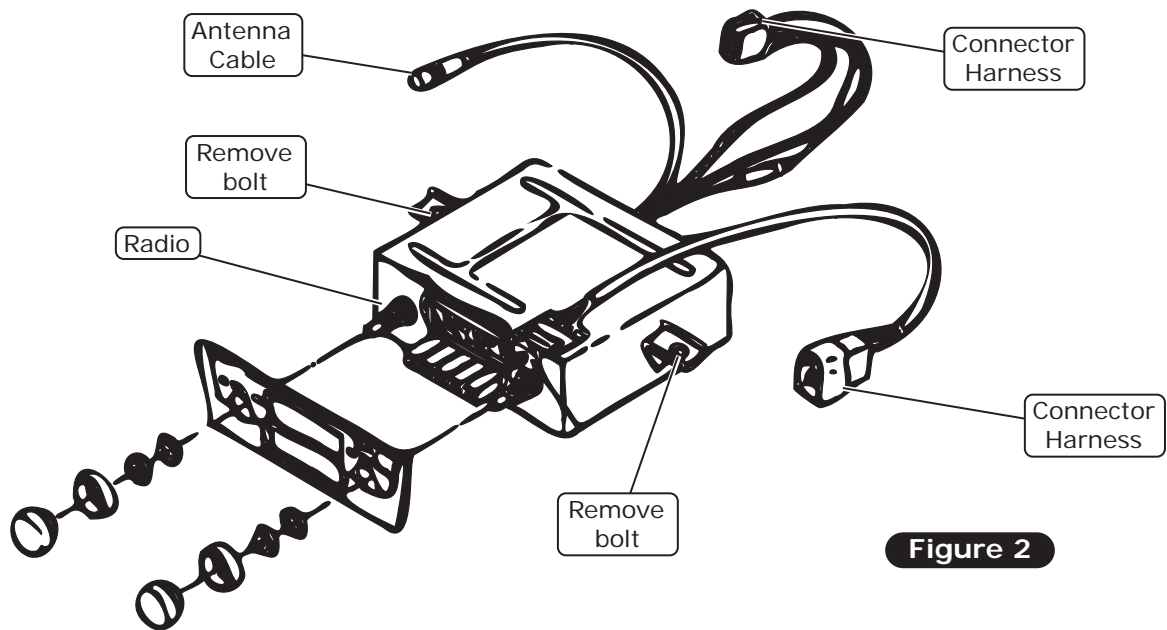

Figure 2

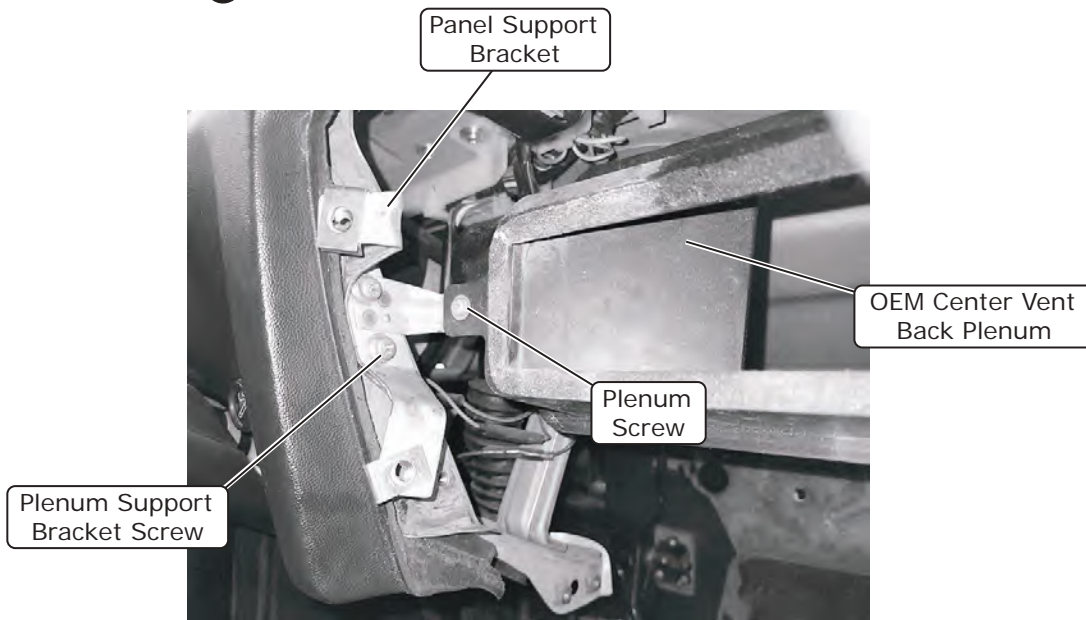

Photo 1



www.vintageair.com

Climate Control Unit Disassembly and Removal

1. Disconnect all climate control panel associated linkages and vacuum hoses at the OEM heater/evaporator core case. **NOTE: Carefully inspect all linkages and vacuum locations to ensure nothing will remain attached to the climate control panel unit. Refer to exploded system diagram on Page 11.**
2. Remove the (2) upper rear most bolts that retain the control panel unit to the evaporator core support (See Photos 1 and 2, below).
3. Disconnect all associated wiring connectors to the climate control unit.
4. **NOTE: Ensure the front lower bolts at the center dash cross member are removed from the prior radio removal (See Photo 3, below).** Remove the (2) rear most lower bolts at the upright stand off bracket (See Photo 3, below).
5. While lifting and supporting the evaporator case, carefully guide the climate control panel unit out from the center dash opening. Discard unit.
6. Temporarily remove the center dash cross member support by removing the (4) bolts securing it to the dash (See Photo 4, below). Retain bolts.



(2) Upper Rear
Most Bolts

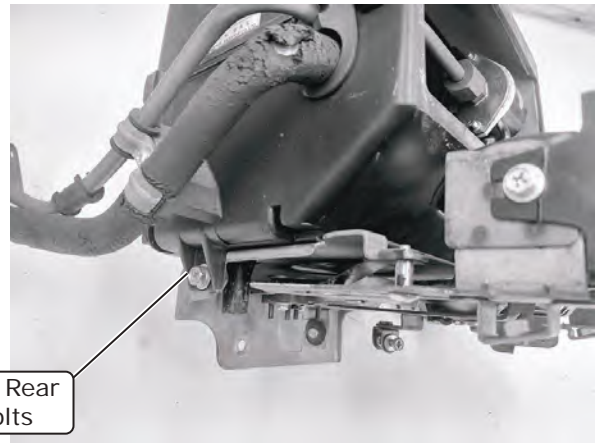
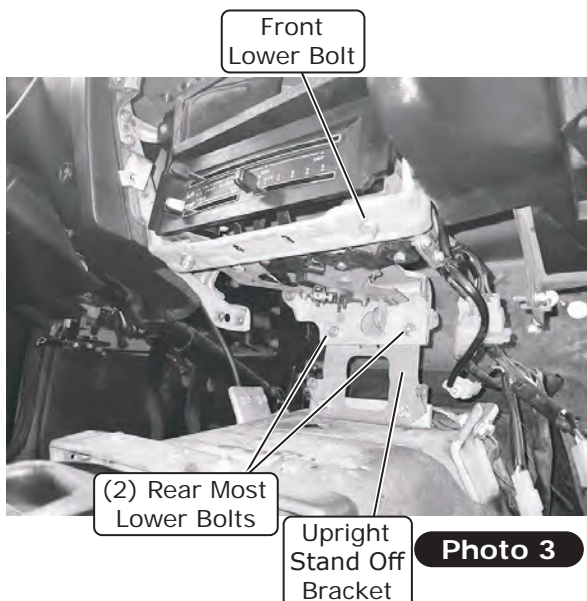

Photo 1

Photo 2



Front
Lower Bolt

(2) Rear Most
Lower Bolts

Upright
Stand Off
Bracket

Photo 3

(4) Bolts
(2 Unseen)

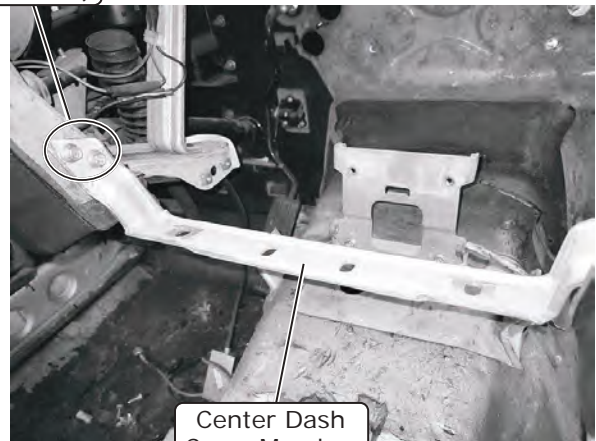

Center Dash
Cross Member
Support

Photo 4



www.vintageair.com

Evaporator & Heater Core Removal

1. Disconnect the securing bracket by removing (2) bolts from the heater core case to the refrigerant hardlines (See Photo 1, below).
2. Carefully guide the evaporator core out from the center dash opening and discard unit.
3. From the under dash passenger compartment side, remove the (1) bolt retaining the fan blower assembly to the cowl hanger and the (2) bolts from the vehicle's firewall (See Figures 1 and 2, below). Disconnect any associated electrical harness connectors, remove blower motor assembly and discard unit. Reinstall cowl hanger bolt (See Figure 3, below). **NOTE: It is critical for Step 3 to be done now. Do not miss or skip this instruction.**

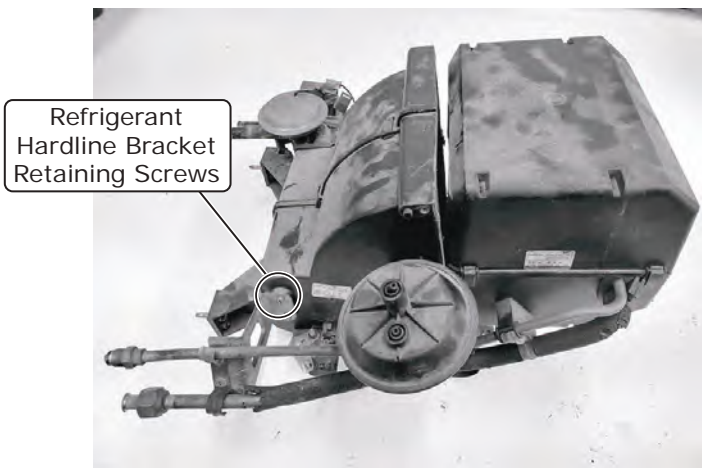

Photo 1

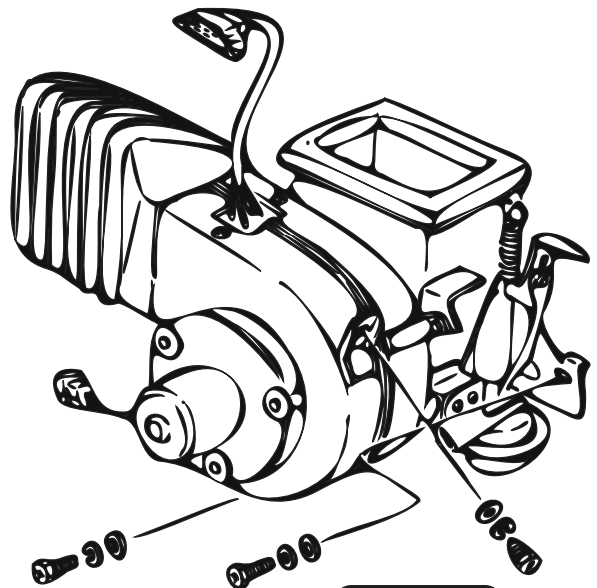

Figure 1

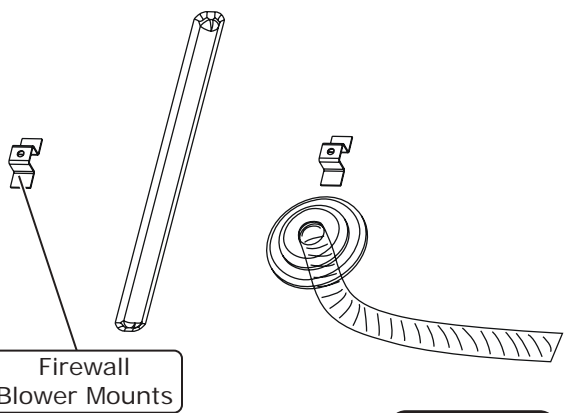
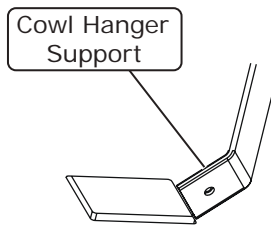

Figure 2

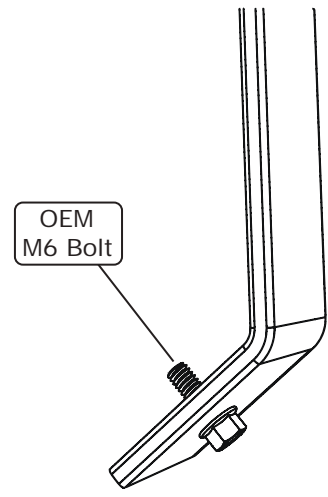

Figure 3



www.vintageair.com

Evaporator & Heater Core Removal (Cont.)

4. Remove all (6) bolts from the upright stand off bracket (See Photo 2, below). Remove bracket and discard.
5. Remove the (2) upper most bolts securing the heater core case to the vehicles cowl (See Photo 3, below).
6. Detach the (2) mounting ears from the heater core case by removing the single screw keeping it retained. Discard brackets (See Photo 4, below). **NOTE: This step is necessary to allow clearance to remove from the dash.**
7. From the engine compartment side of the firewall, locate the (2) nuts keeping the heater core case against the firewall and remove (See Figure 4, below). Discard hardware.



Photo 2

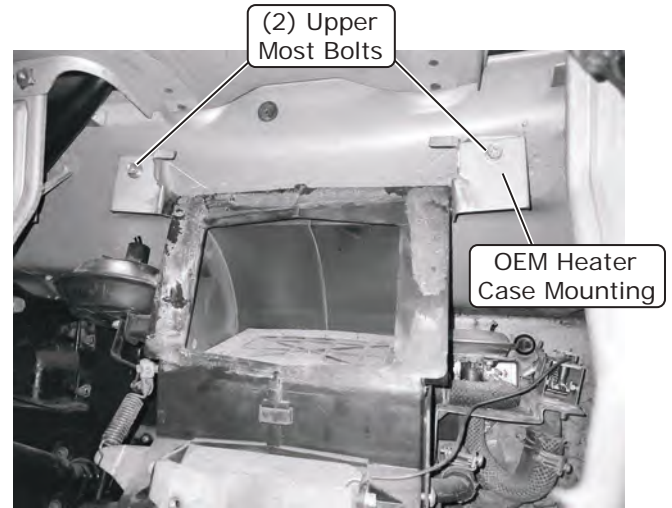

Photo 3

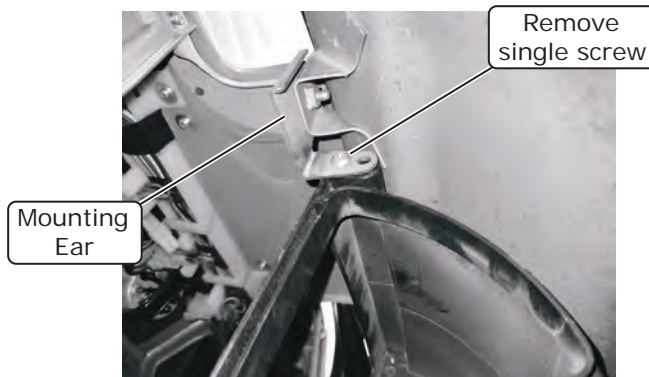

Photo 4

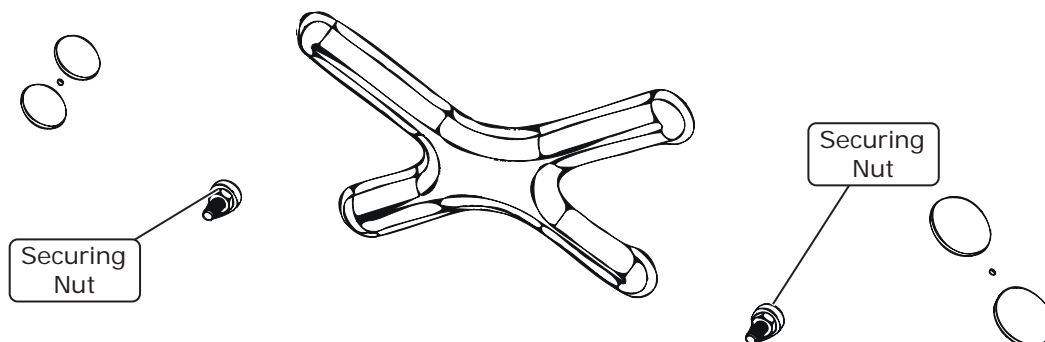

Figure 4



www.vintageair.com

Evaporator & Heater Core Removal (Final)

NOTE: Identify and remove all supports, brackets, and any other items that would keep the heater core case from being removed at this time.

8. Disconnect all associated duct hoses connecting to the heater core case.
9. Pull the heater case away from the firewall and rotate the unit 90° counter-clockwise (See Photo 5, below).
10. Carefully remove the heater case through the center dash opening (See Photo 6, below). **NOTE:** Keep the transmission shift lever in the furthest back position to allow unit removal (See Photo 7, below). Discard unit.



Pull heater case away from firewall and rotate unit 90° counter-clockwise

Photo 5



Carefully guide heater case unit out from center dash opening

Photo 6



Keep transmission shift lever in furthest back position to allow unit removal

Photo 7



www.vintageair.com

Firewall Modification and Fresh Air Cap Installation

1. With the supplied template, place it against the passenger-side interior firewall where the template's V-groove feature falls and centers vertically into the firewall stamping. Slide the template's upper edge to the cowl's surface and ensure flushed contact (See Figure 1, below).
2. Transfer all (4) 1/4" holes, remove the template and drill 1/4" diameter holes through the firewall.
3. With the supplied fresh air cap, apply silicone, around the fresh air caps edges (See Photo 1, below).
NOTE: Clean for a flat even surface before installing the fresh air cap. The template has an arm assist feature to keep the fresh air cap plate supported to allow the silicone to cure.
4. Install the fresh air cap over the opening then pin the template on as shown in Figure 2, below. Using the supplied 1/4-20 x 3/4" serrated flange bolts, let the fresh air cap cure (See Photo 1, below). **NOTE: If desired you may bolt the fresh air cap to the cowl for increased leak prevention.**

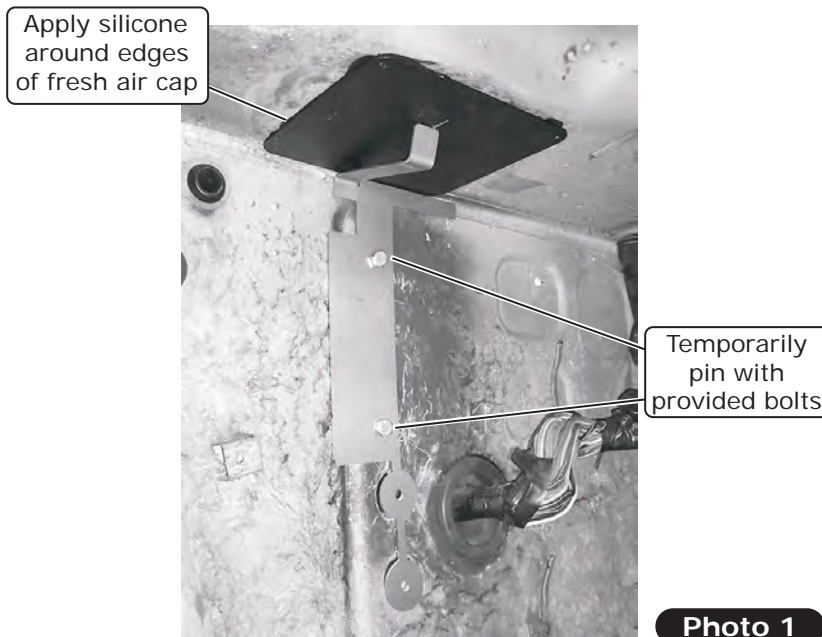
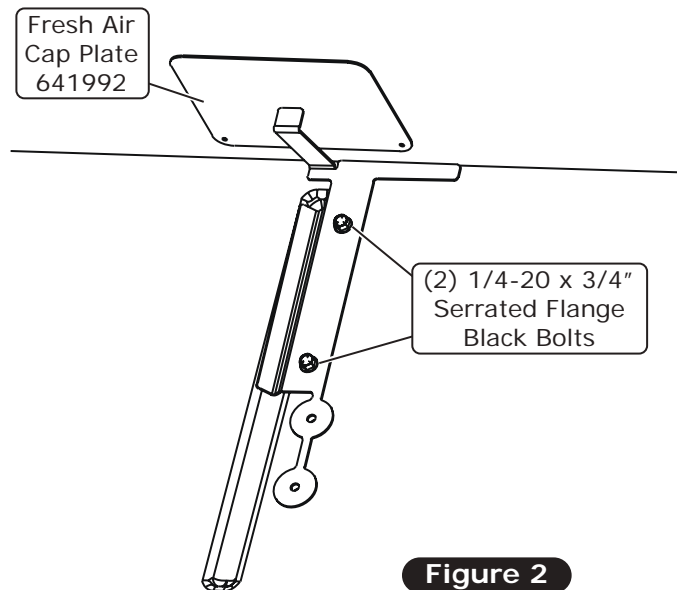
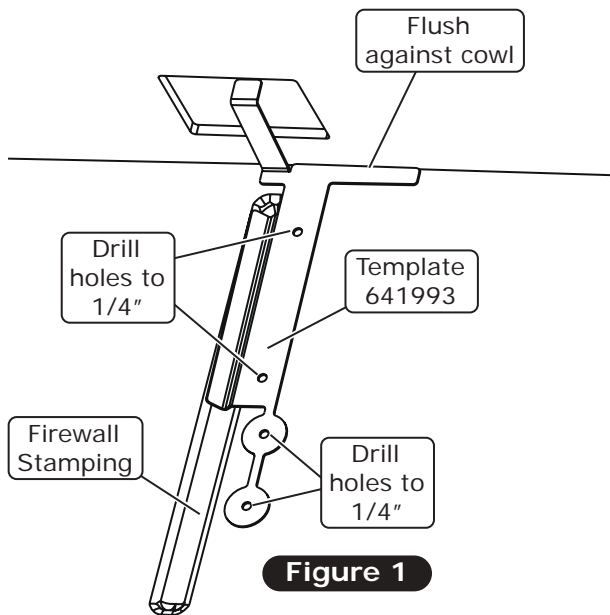



www.vintageair.com

Firewall Modification and Fresh Air Cap Installation (Cont.)

5. Remove the hardware and template from the firewall. Discard the template. Increase the diameters of the (2) lower 1/4" alignment holes to 1 1/4" (See Figure 3, below). **NOTE: Do not exceed hole size.**

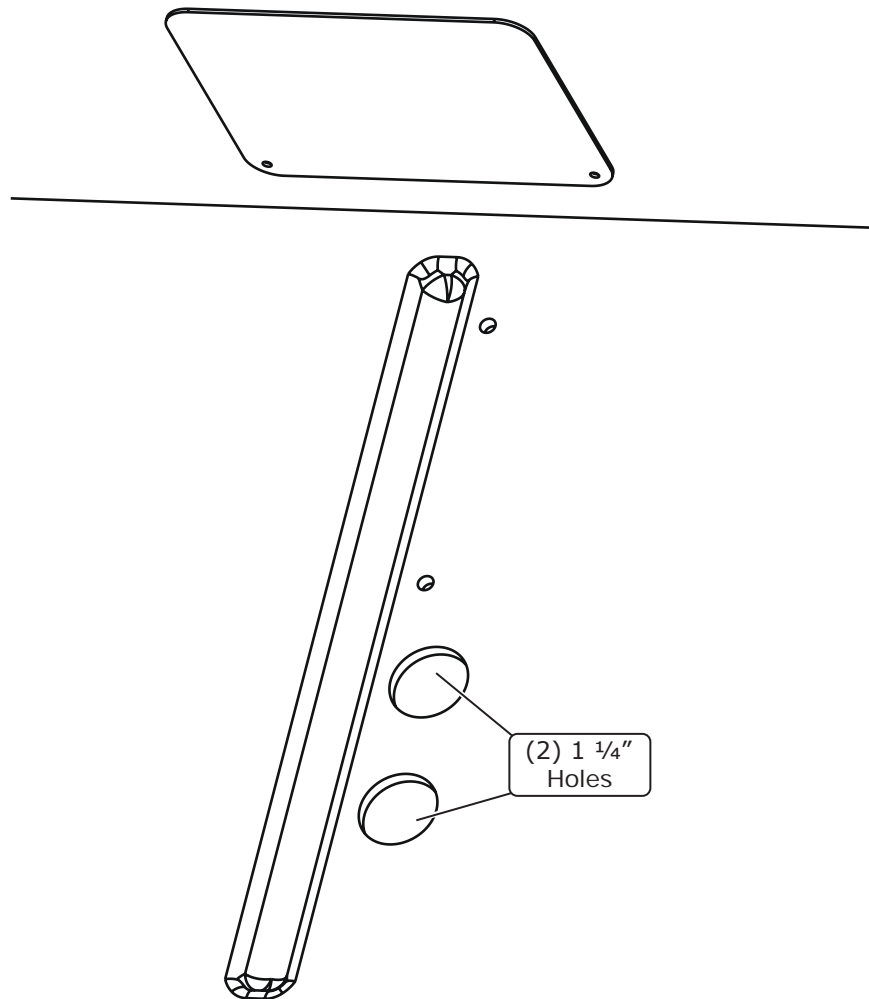

Figure 3



www.vintageair.com

Wiring Harness Installation

NOTE: Vehicle shown in photos may differ, for reference only.

1. From the passenger-side interior firewall compartment, choose from (2) recommended "X" hole locations (See Figure 1, below). Drill a 5/8" hole.
2. Insert the supplied 7/8" O.D. x 3/8" I.D. grommet into the 5/8" hole.
3. With the supplied wiring kit, begin installing the main harness in the passenger foot well, start by routing the heater control valve plug through the previously installed grommet (See Photo 1, below).
4. Route the red/white twisted wires through the grommet followed by the single blue wire (See Photo 2, below).
5. Attach the white ground wire with ring terminal to a suitable ground on the firewall or kick panel area (See Photo 3, below).
6. Mount the main harness relay where it will not interfere with the evaporator installation (See Photo 4, below).
7. Once the single blue wire is routed through the grommet, into the engine compartment, route the wire along the passenger frame rail until it meets to the A/C drier, located at the front side of the radiator core support. There you will crimp a supplied blue female spade connector to the wire and connect directly to one terminal post of the binary pressure safety switch. **NOTE: Condenser kit must be installed to complete this step.**
8. Carefully pull the excess wiring into the engine compartment. Leave some slack inside vehicle. Refer to Gen 5 Wiring Diagram and Wiring Instructions on Pages 36 and 37, for an in depth wiring schematic of the main harness.

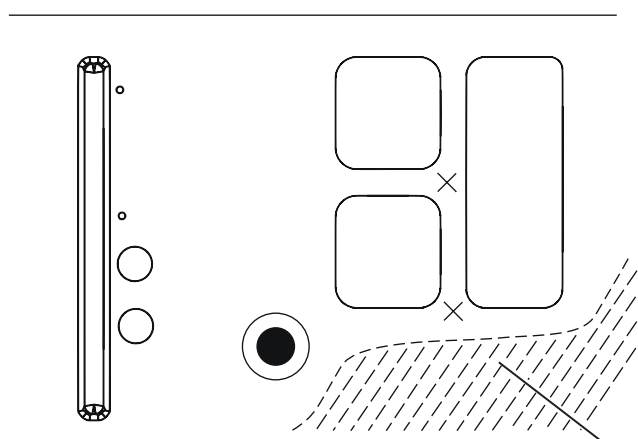

View from Firewall Interior

Figure 1

Unserviceable wheel well area

Route heater control valve plug through grommet

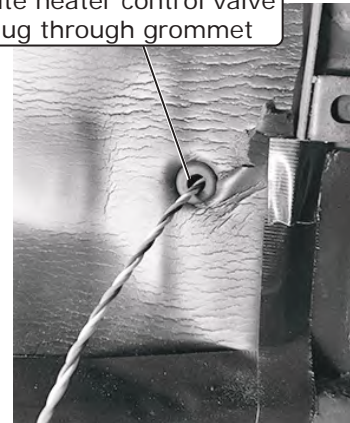

Photo 1

Route red/white twisted wires, and single blue wire through grommet



Photo 2

Attach white ground wire with ring terminal to suitable ground

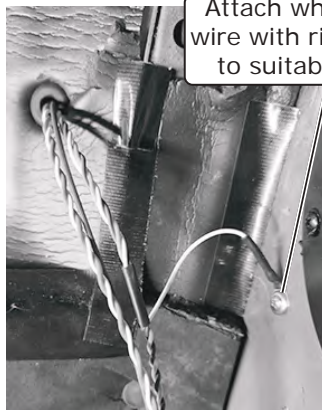

Photo 3

Mount main harness relay where it will not interfere with evaporator installation



Photo 4



www.vintageair.com

Junction Block Relocation & Bracket Installation

1. Temporarily disconnect all electrical connectors to the junction block (See Photo 1, below).
2. Locate the vehicle's ignition relay and disconnect the connector from the relay (See Photo 2, below).
3. Remove the M6 bolt that retains the junction block to the vehicle's cowl support (See Photo 1, below). Do not discard bolt.
4. With the supplied relocation bracket, temporarily install it onto the cowl support and reuse the M6 bolt to secure the bracket (See Photo 3, below).
5. Mark the 2nd anchoring support on the firewall from the weldnut (See Photo 3, below). Temporarily remove the relocation bracket again.
6. With a 1/4" drill bit, drill through the marked location.
7. Install the supplied 1/4-20 full-threaded stud onto the bracket as shown in Figure 1, below. **NOTE: Leave about 3/8" - 1/2" sticking out.**
8. Mount the relocation bracket to the firewall through the previously drilled 1/4" hole. Secure the stud from the engine bay with the supplied 1/4" USS flat washer and 1/4-20 nut with star washer (See Figure 1 and Photo 4, below).
9. Secure the relocation bracket to the cowl with OEM M6 bolt (See Photo 4, below).
10. With the supplied 1/4-20 x 3/4" black serrated flange bolt, secure the OEM junction block to the relocation bracket (See Figure 1 and Photo 4, below).

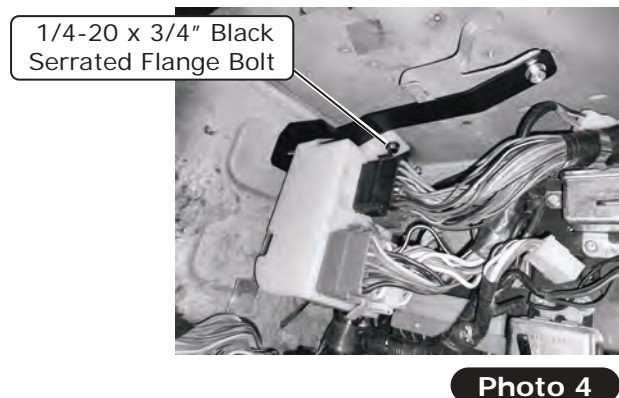
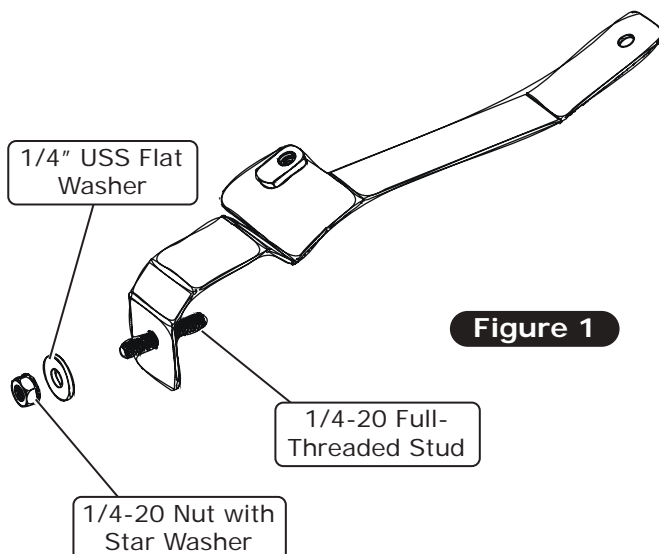
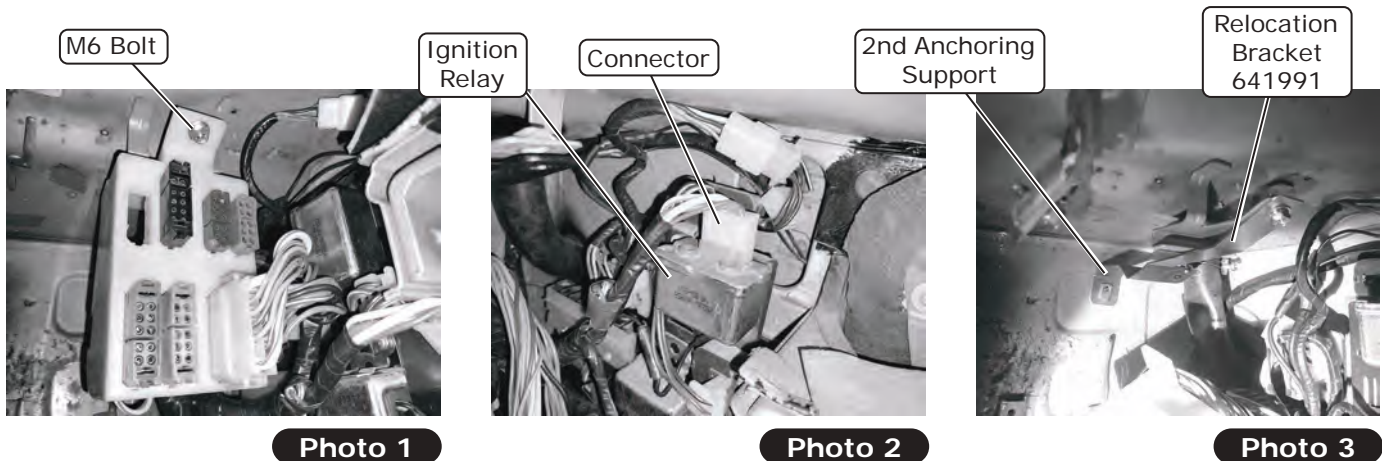



www.vintageair.com

Junction Block Relocation & Bracket Installation (Cont.)

- Remove the (2) screws for the ignition relay, reposition the relay 90° counter-clockwise. Reconnect the ignition relay harness connector (See Photos 5 and 6, below).

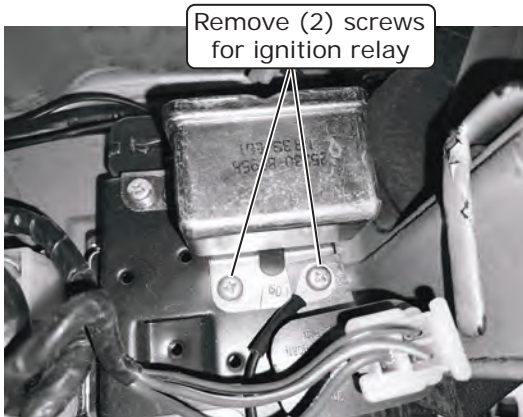
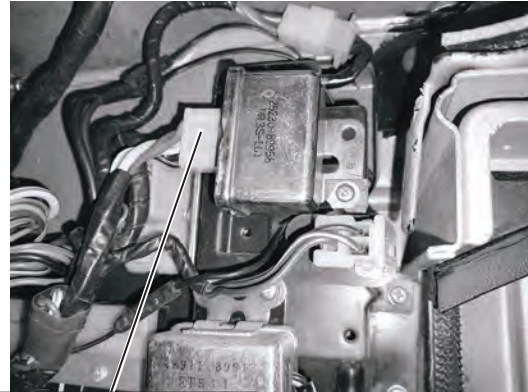

Photo 5



Reconnect ignition relay harness connector

Photo 6

Heater Ports Cover Plate Installation

- From the passenger-side interior firewall, place the cover plate against the heater hose holes and keep centered (See Figure 1, below).
- Mark and drill (2) 1/8" mounting holes (See Figure 2, below).
- Increase the (2) heater hose holes up to 1.25" diameter (See Figure 2, below).
- From the engine compartment side of the firewall, install the cover plate using (2) #8 x 1/2" wide head screws, and the cover plate rubber boot (See Figure 3 and 4, below). Install onto the firewall.

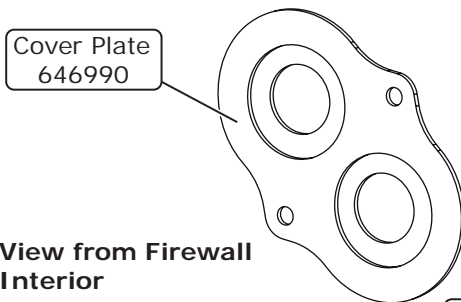

View from Firewall Interior

Figure 1

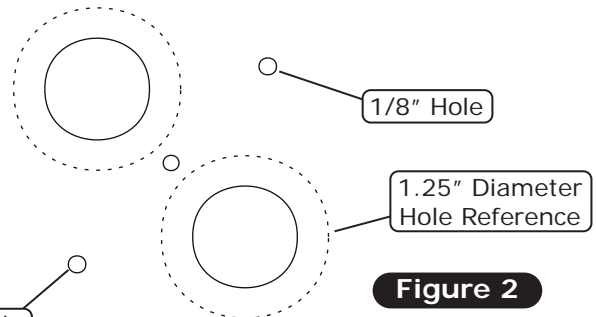
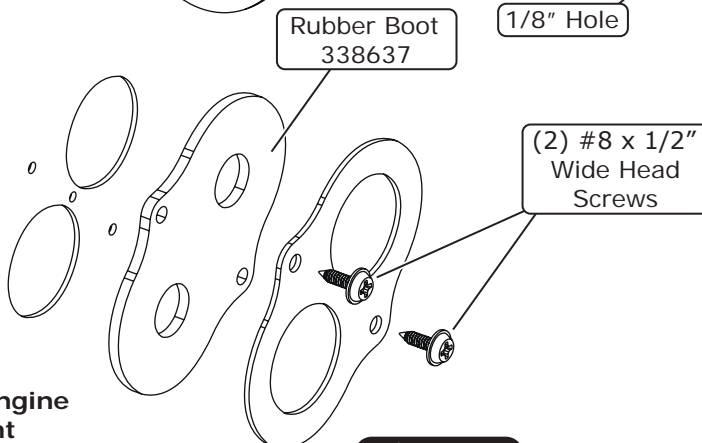

Figure 2



View from Engine Compartment

Figure 3



Installation Complete

Figure 4



www.vintageair.com

Firewall Preparation and Heater Hose Installation

1. Locate the prior (2) OEM heater core case anchoring holes. Enlarge the (2) holes to 1/2" diameter.
2. With the (2) supplied 1/2" plastic plugs, insert the plugs into the holes.
3. With the supplied A/C port cover plate and a supplied #14 x 3/4" washer head screw, locate the OEM A/C refrigerant ports and install the cover plate (See Figure 1, below). **NOTE: Apply silicone to the perimeter of the cover plate for proper weather seal.**
4. Remove the main vacuum feed hose for the OEM climate control assembly from the firewall. With the supplied 7/8" plastic plug, plug the vacuum feed hose hole on the firewall.
5. Cut (2) 40" lengths of 5/8" I.D. heater hose.
6. Insert hoses into the upper and lower heater ports through the firewall. **NOTE: Soapy water is recommended to ease hose insertion.**
7. From the inside passenger compartment, pull both heater hoses through until about 1 foot is left on the engine bay side.

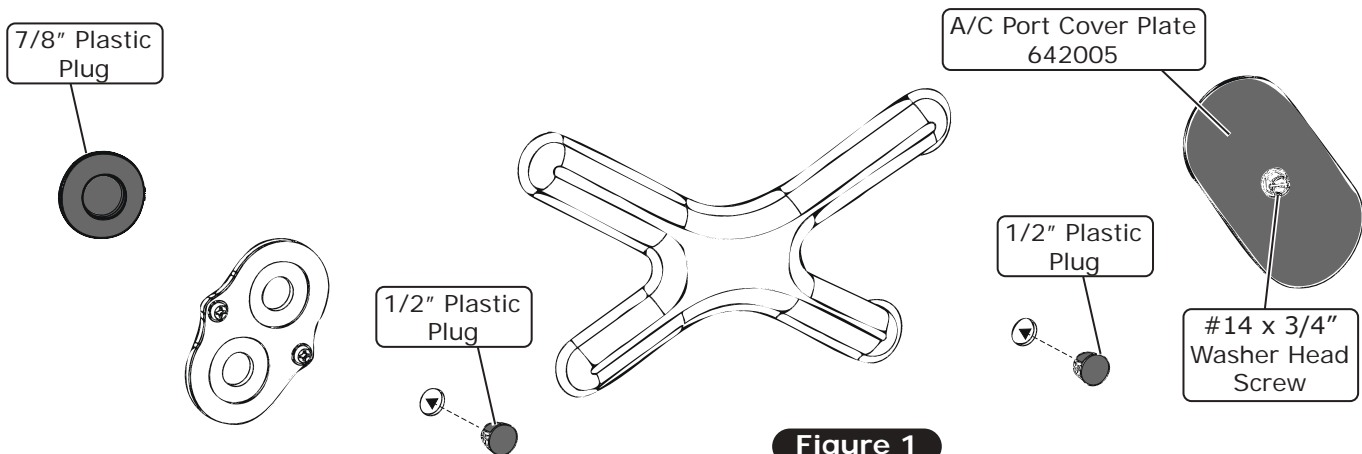

Figure 1

Defrost Duct & Dash Vent Adapters Installation

1. From the top of the dash, remove the (2) screws from the OEM defrost ducts (See Figure 1, below).

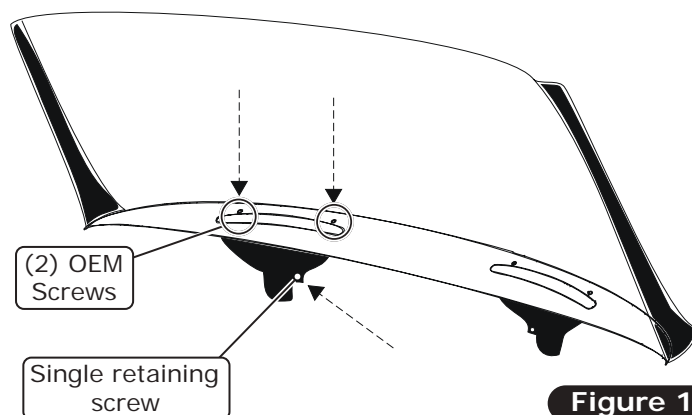

Figure 1



www.vintageair.com

Defrost Duct & Dash Vent Adapters Installation (Cont.)

2. With the (2) supplied defrost ducts, (2) defrost duct support brackets, (6) S-clips, and (4) 1/4" U-nuts, assemble items as shown in Figure 2, below.
3. Install defrost duct assemblies through the opening on top side of the dash (See Figure 3 and Photo 1, below).
4. With the (4) supplied 1/4-20 x 3/4" serrated flange bolts, secure defrost ducts to the cowl from under dash.
5. Remove the OEM duct hoses from both driver and passenger side dash louvers. Discard OEM hoses.
6. For driver-side louver adapter install, temporarily disconnect the speedometer cable for clearance.
7. Driver-side louver clearance is limited. Route the duct hose over the steering column support and down toward the louver (See Photo 2, below).
8. Insert the hose adapter into the duct hose then connect to the driver-side louver housing (See Photo 3, below). Reconnect the speedometer cable (See Photo 4, below).

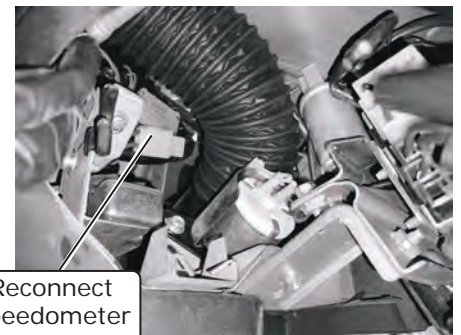
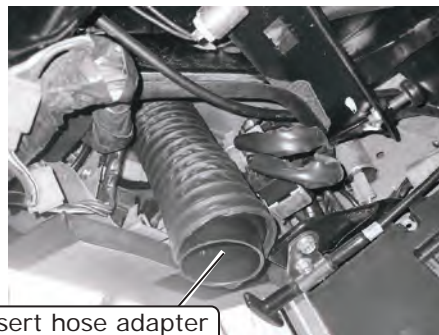
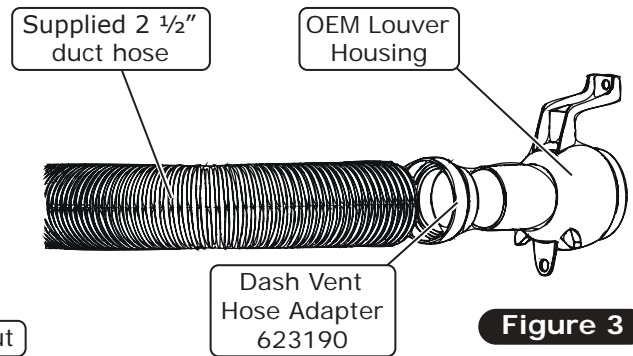
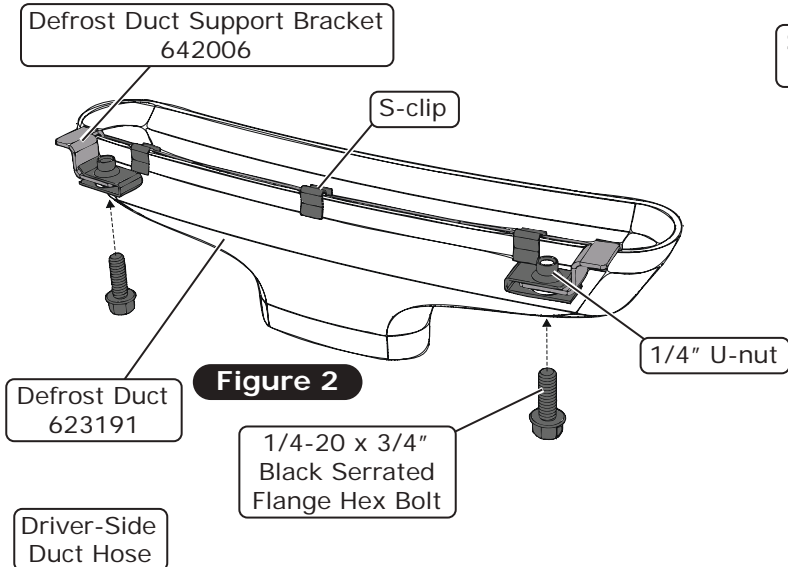



www.vintageair.com

Center Louver Housing Adapter Installation

1. Cut and remove the support braces on the both left and right hand plenum support brackets (See Photos 1 and 2, below).
2. Install the plenum support brackets back onto the vehicle's dash frame.
3. Place the center vent adapter over the center vent. Secure the adapter to the center vent using (4) 1/4-20 x 3/8" black serrated flange bolts.
4. Refer to the control panel installation instructions to proceed to the next steps.
5. With the supplied 2 1/2" duct hose, cut (2) hoses to their required lengths for each center louver port, then connect the duct hoses to the louver adapters. **NOTE: Refer to duct hose routing, Page 42, for detailed cut length and routing.**

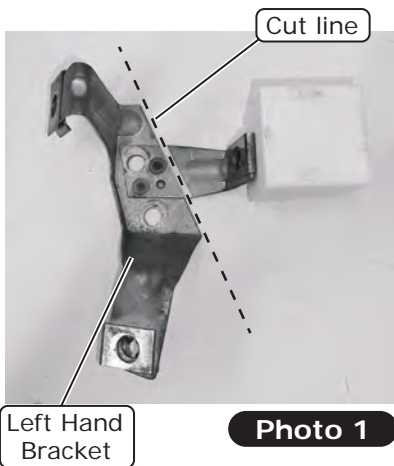

Photo 1

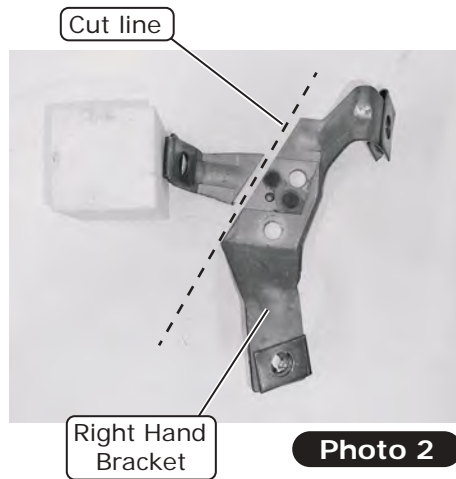
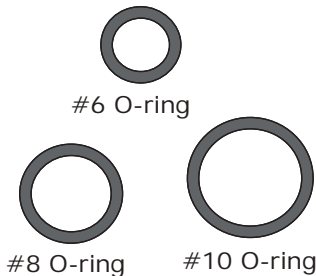

Photo 2



Photo 3

Lubricating O-rings & Fitting Torque Specs



NOTE: Standard torque specifications:

- #6: 11 to 13 ft-lb.
- #8: 15 to 20 ft-lb.
- #10: 21 to 27 ft-lb.

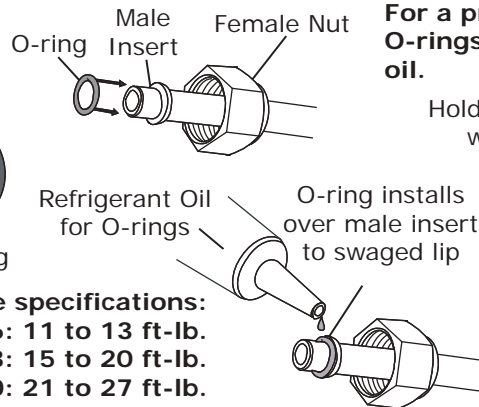

For a proper seal of fittings: Install supplied O-rings as shown and lubricate with refrigerant oil.

Hold with this wrench

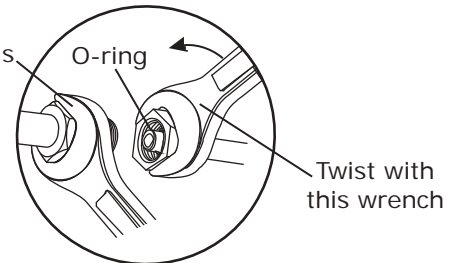

The use of a backup wrench is recommended to reduce the chance of damaging the fittings/hardline.



www.vintageair.com

Properly Seated O-ring Land

When installing a hardline or A/C hose fitting onto the evaporator module, ensure the O-ring land is seated properly (See Photo 1, below). An improperly seated O-ring land (See Photo 2, below) can cause a leak. To properly install the fitting, slide the hardline or A/C hose nut back to expose the O-ring land and seat it onto the evaporator module fitting. Then, slide the hardline or A/C hose nut forward and thread it onto the evaporator module fitting, ensuring the O-ring land does not move or lift.

Properly Seated O-ring Land



Photo 1

Improperly Seated O-ring Land

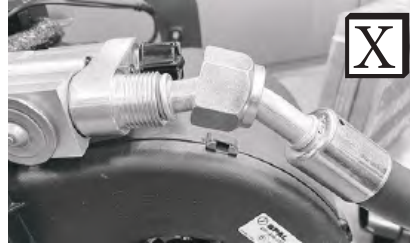

Photo 2

NOTE: Photos shown are for reference only. Fittings may vary depending on kit received.

Evaporator Preparation & Installation

NOTE: Vintage Air recommends using heat-blocking insulation in the area around the evaporator module (firewall, kick panel, inner cowl, firewall covers). Due to tight clearance for the evaporator module between the firewall and dash, Vintage Air recommends an insulation thickness of no more than 1/4". To ensure a watertight seal between the passenger compartment and the vehicle exterior, for all bolts passing through the firewall, Vintage Air recommends coating the threads with silicone prior to installation.

1. Install the (4) supplied 1/2" plastic plugs and (1) well nut, onto the module (See Figures 1 and 2, below).

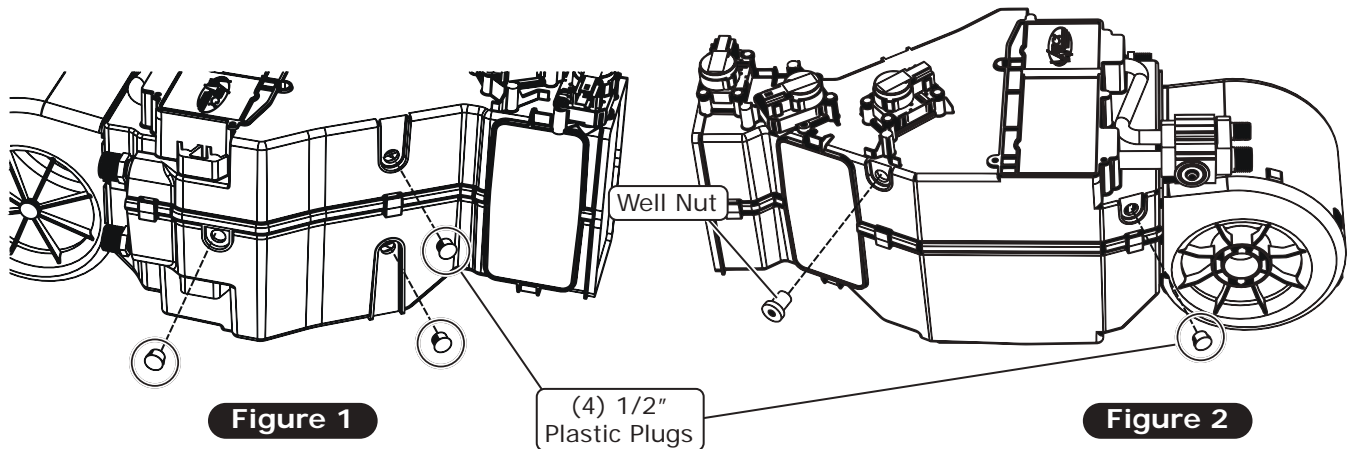

Figure 1

(4) 1/2"
Plastic Plugs

Figure 2



www.vintageair.com

Evaporator Preparation & Installation (Cont.)

2. Temporarily remove the (3) ECU mounting screws (See Figure 3, below). Remove the ECU from the module.
3. Install the supplied cowl bracket onto the module (See Figure 4, below). Secure the bracket with a supplied 1/4-20 x 1" serrated flange bolt into the well nut, then reinstall the ECU. **NOTE: Do not tighten ECU mounting screws yet.**
4. Install the (2) supplied heater hardlines onto the evaporator module (See Figure 5, below). **NOTE: Keep both hardlines parallel to one another and perpendicular to module's case.**
5. With the supplied firewall bracket and (4) #10 x 5/8" screws install the bracket onto the evaporator case and secure with screws (See Figure 6, below).

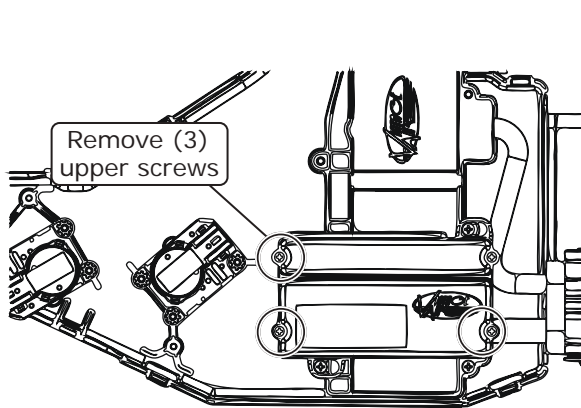

Figure 3

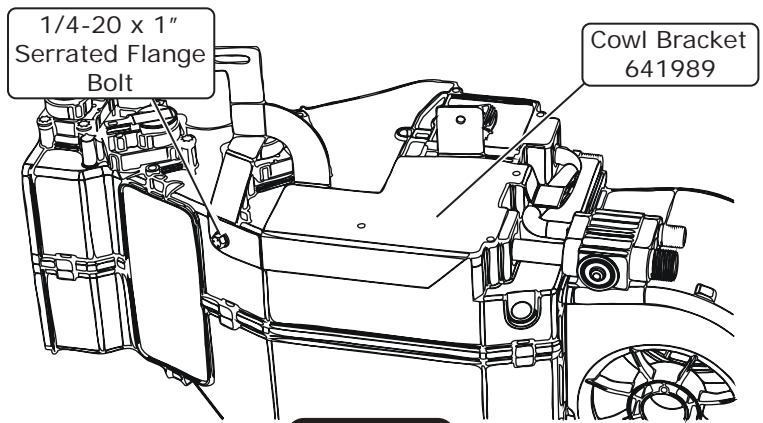

Figure 4

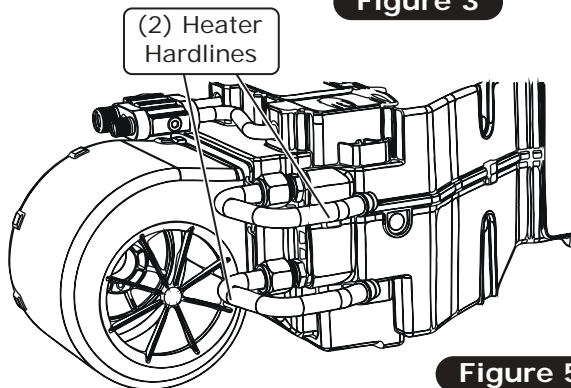

Figure 5

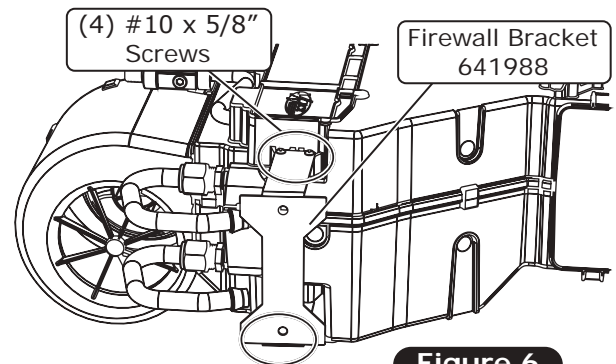

Figure 6

Bracket has a design intent of an angled feature to firewall placement

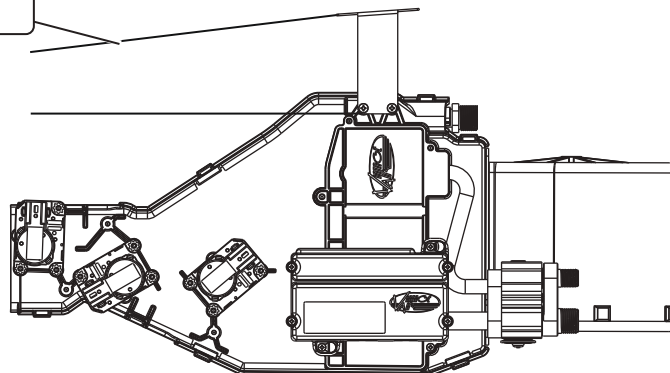

Figure 7



www.vintageair.com

Evaporator Preparation & Installation (Cont.)

6. Install the dash, defrost and floor plenums onto the module case and secure with spring clips (See Figures 8 - 10, below).

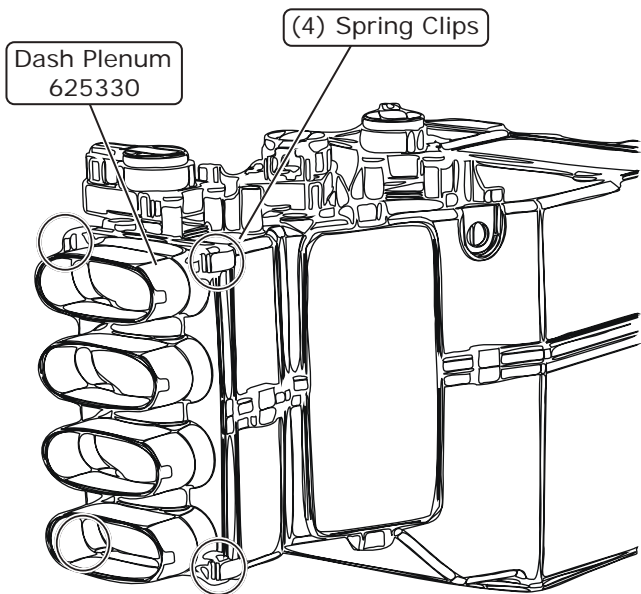

Figure 8

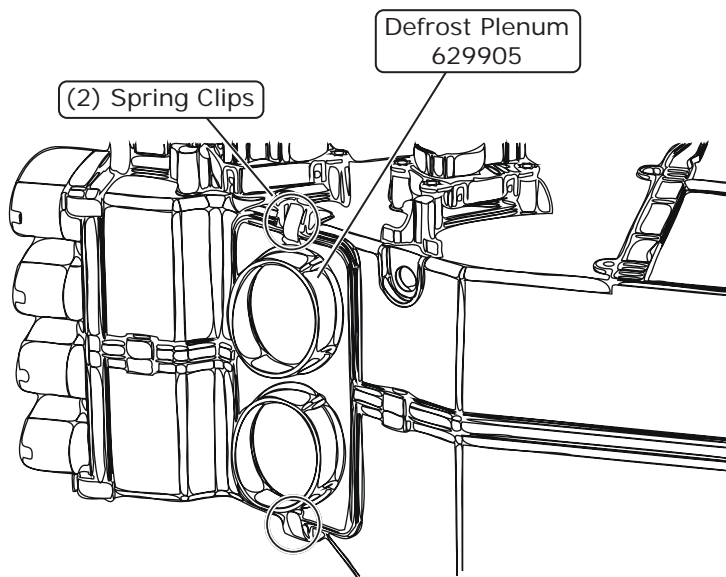

Figure 9

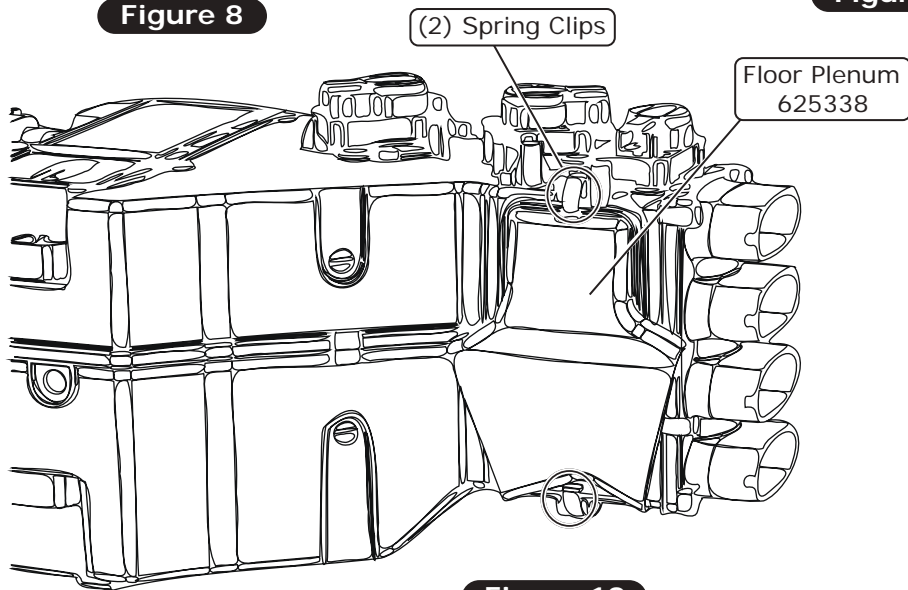

Figure 10



www.vintageair.com

Evaporator Preparation & Installation (Cont.)

7. With the (2) 1/4-20 full-threaded studs, install each stud to the firewall bracket weld nuts (See Figure 11, below). **NOTE: Studs have an Allen key pocket end for 1/8" key'd wrench. Allen key pocket is to be facing out and away from the bracket to be accessible for later removal (See Figure 11, below).**
8. Place the evaporator module onto the passenger-side floor board with the heater hardlines facing up, locate the (2) heavy gauge orange and white wires coming off. Insert the (2) wires through the previously installed wiring grommet on the firewall (See Photo 1, below).
9. Install the (2) 5/8" heater hoses coming through the firewall, connect the lower hose onto the lower heater hardline and the upper hose onto the upper heater hardline, secure with the (2) supplied hose clamps.
10. Reposition the evaporator case to resemble Photo 2, below. Carefully lift the evaporator case up behind the dash while feeding the excess heater hose through the firewall.

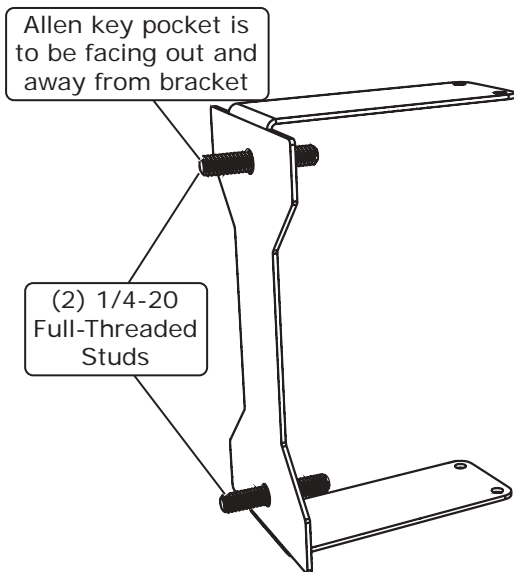

Figure 11

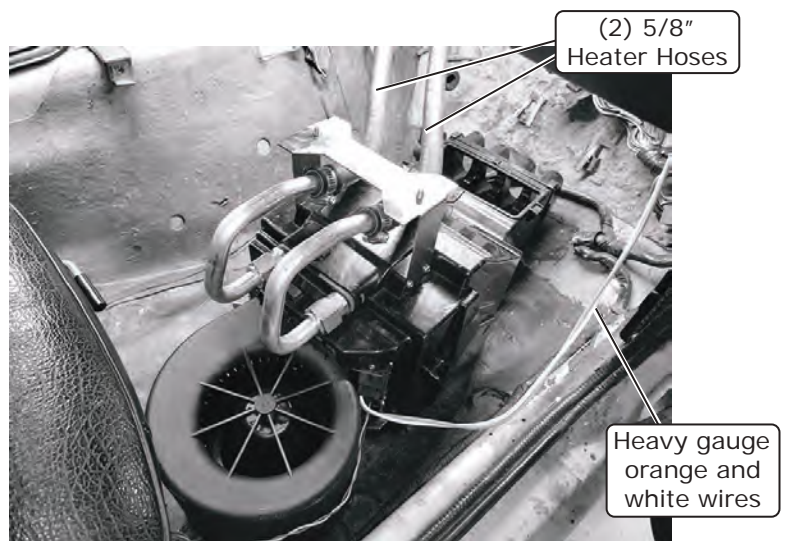

Photo 1

Alternate from pushing to pulling heater hoses into engine compartment

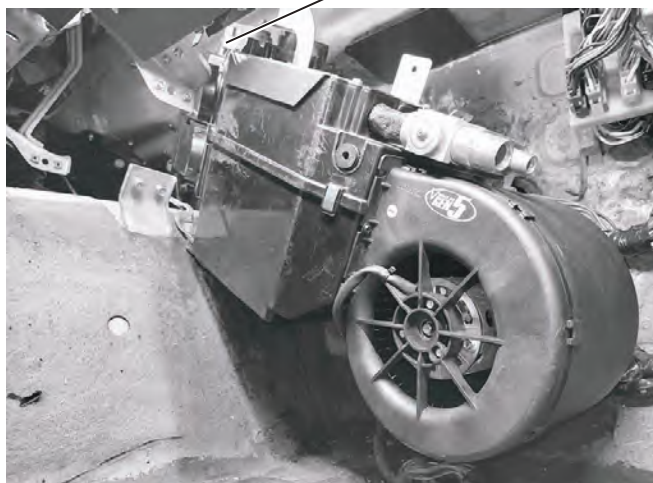

Photo 2



www.vintageair.com

Evaporator Preparation & Installation (Final)

11. Once the firewall bracket is aligned to the (2) previously drilled 1/4" holes and the full-threaded studs are protruding through the firewall into the engine compartment. Verify the lower right cowl bracket is resting on the OEM blower hanger with the reused bolt in the slotted features (See Figure 12, below). With the supplied M6-1.0 locknut, secure the bracket to the hanger.
12. Align upper left cowl bracket to the vehicle's OEM heater case cowl mount (See Figure 12, below). With the supplied T30 M6 x 1" truss head bolt, secure the bracket to the mount.
13. From the engine compartment, remove the full-threaded studs one at a time, and install the (2) supplied 1/4-20 x 3/4" black serrated flange bolts in their place (See Figure 13, below).
14. Tighten ECU mounting screws.

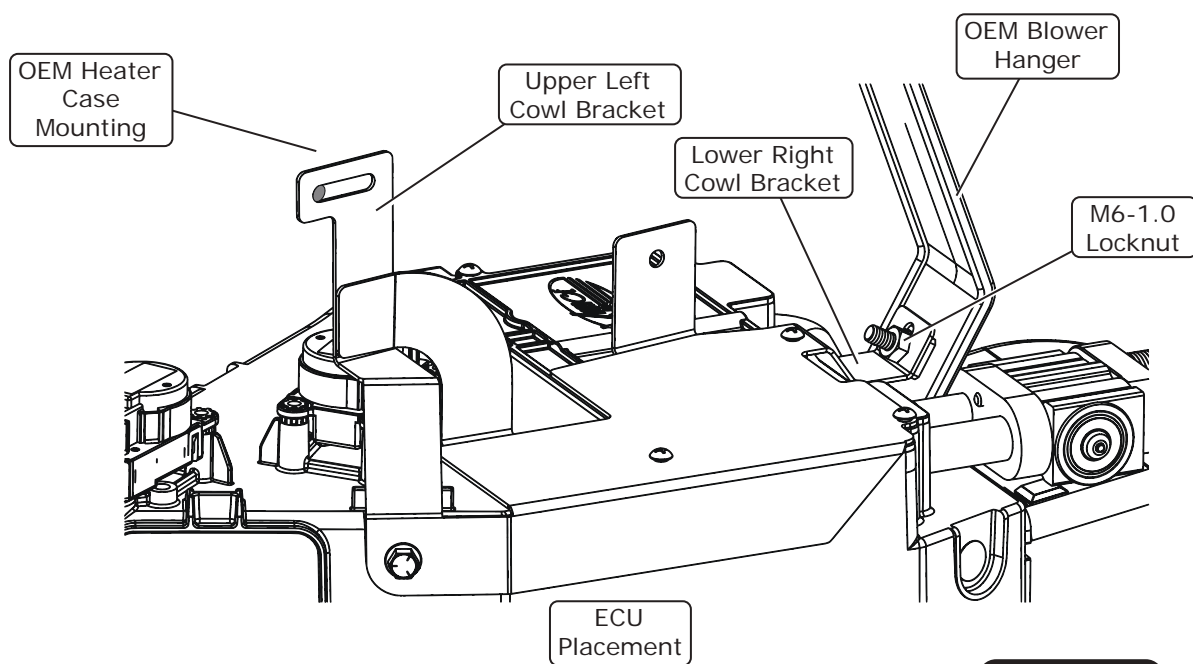

Figure 12

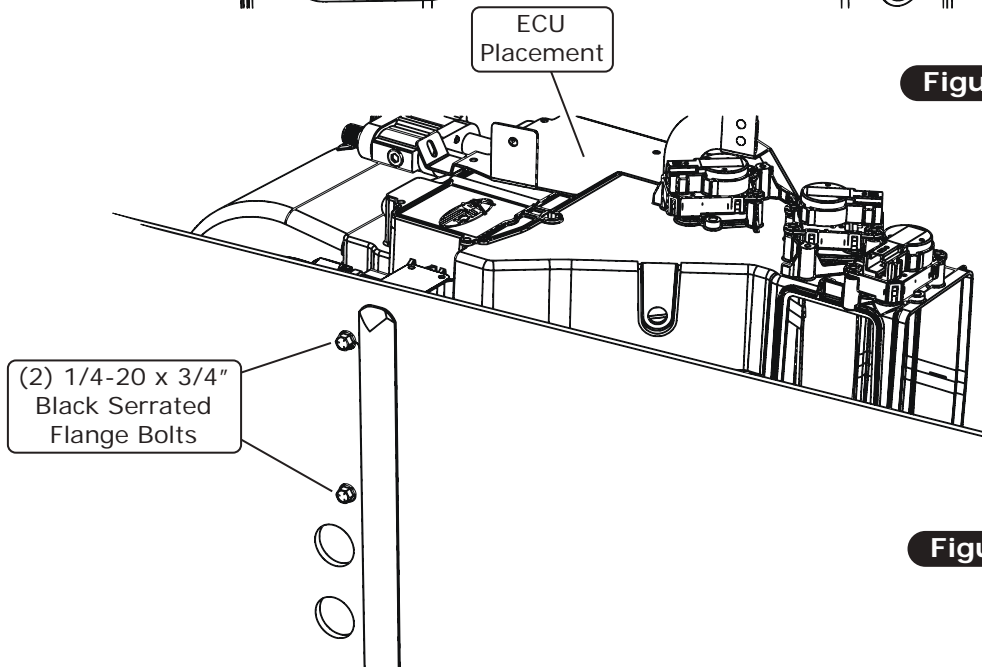

Figure 13



www.vintageair.com

Drain Hose and Grommet Installation

1. Locate the evaporator drain on the bottom of the evaporator case.
2. Mark the transmission tunnel about 3.5" lower than the drain about 1" back from the firewall.
3. Before drilling, check the engine bay side for any potential interference. Then drill a 1" hole on the previously marked spot.
4. With the supplied 1 1/4" O.D. x 11/16" I.D. grommet, insert the grommet into the 1" hole.
5. With the supplied 1/2" drain hose, cut the hose to 9".
6. With the supplied 1/2" drain elbow, insert the elbow into the 9" drain hose cut section. **NOTE: Drain elbow should be facing down in engine bay.**
7. Insert the drain elbow end into the grommet.
8. Connect hose end to evaporator case drain port.

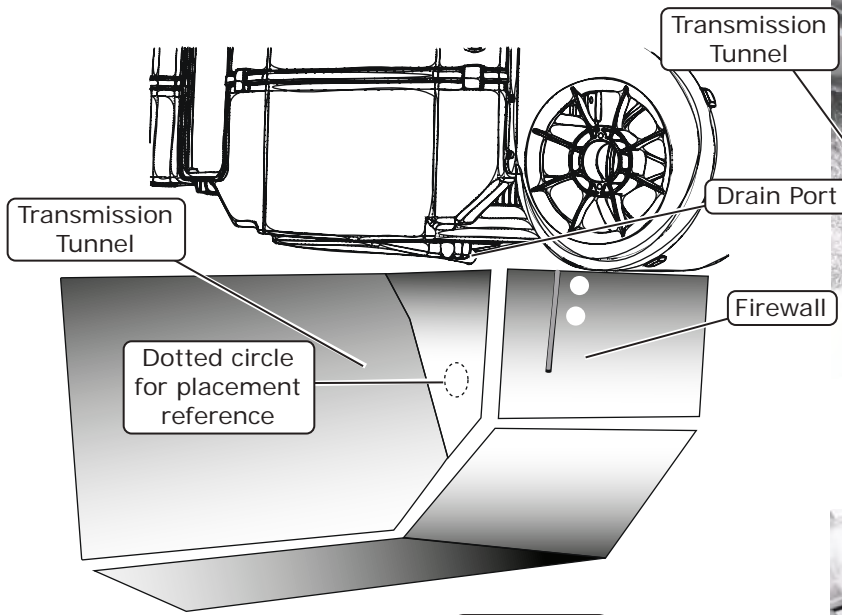

Figure 1

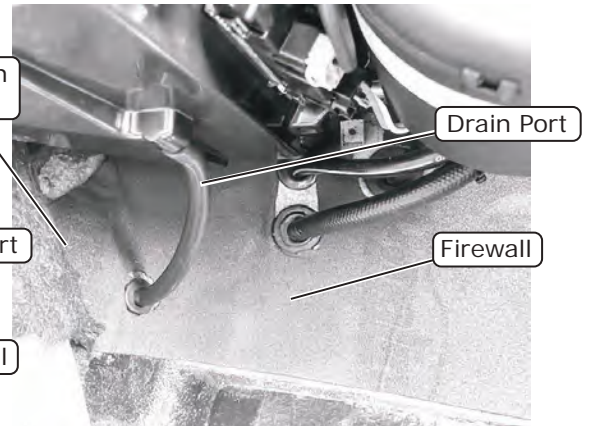
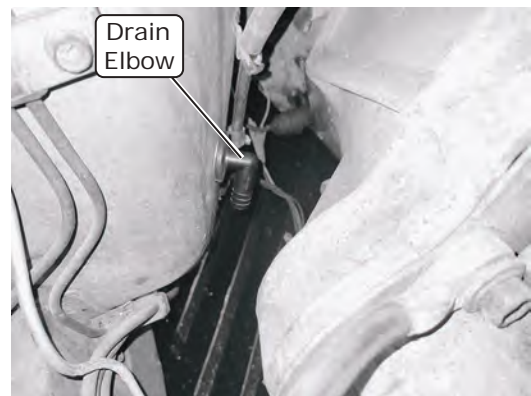

Photo 1



View from Engine Compartment

Photo 2

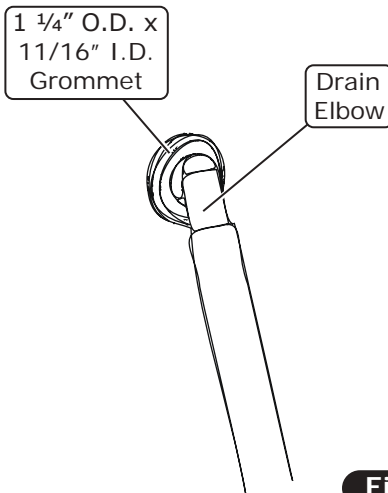

Figure 2

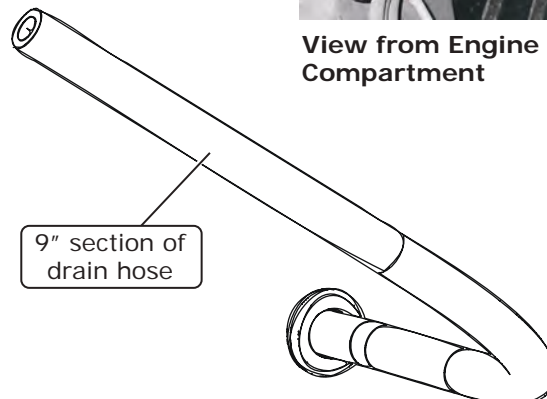

Figure 3



www.vintageair.com

Drain Hose and Grommet Installation (Cont.)

8. Plug the OEM evaporator drain hole on the transmission tunnel with supplied 1 1/4" x 1" grommet.

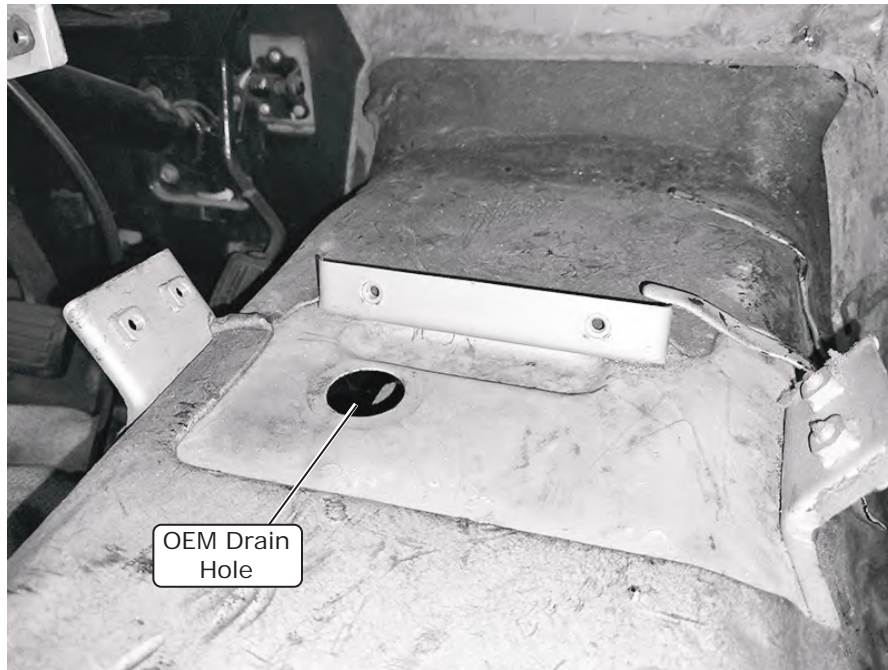

Photo 1

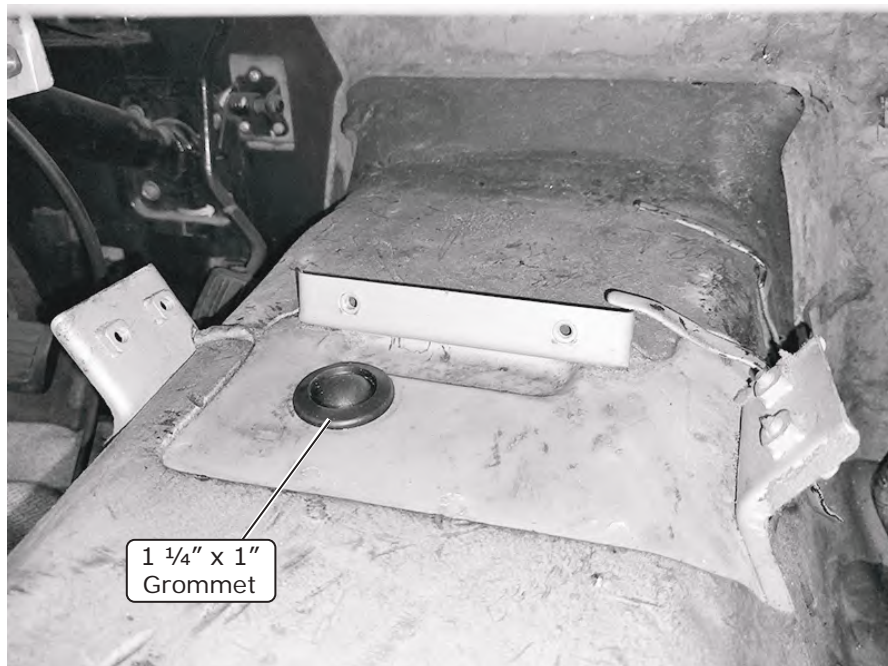

Photo 2



www.vintageair.com

Heater Control Valve Installation

NOTE: Vintage Air systems use 5/8" heater connections. On engines equipped with 3/4" hose nipples, these will need to be removed and replaced with 5/8" nipples (not supplied). For water pumps with a cast-in 3/4" heater outlet, a 3/4" x 5/8" reducer fitting (not supplied) or molded hose will need to be installed in the heater hose.

1. Pull all excess hose into engine bay, ensure hoses are not kinked or twisted under the dash.
2. Trim the upper hose to length and connect it to the water port on the rear of the block.
3. Connect the lower hose to the water pump fitting toward the front of the engine and install the heater control valve in line (See Photos 1 and 2, below). **NOTE: The heater control valve is directional refer to Figure 1, below, for correct installation.**

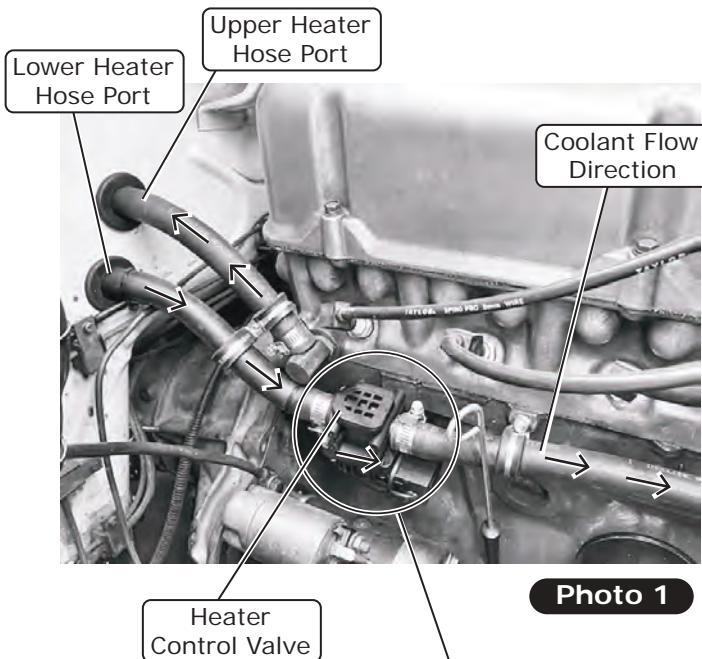

Photo 1

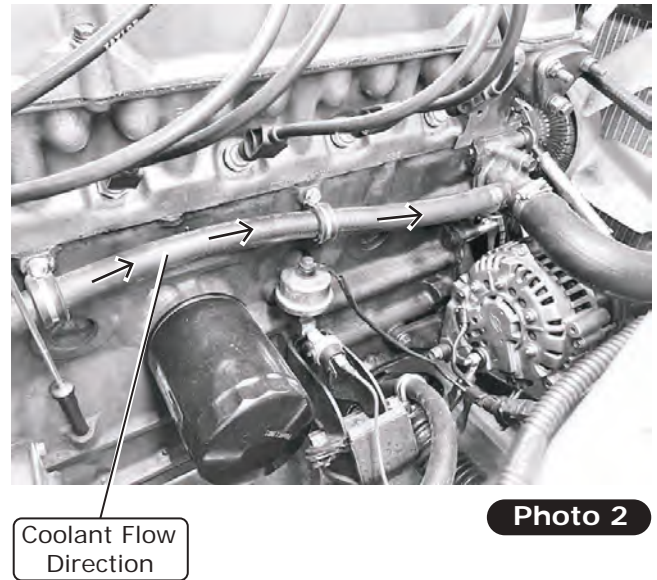

Photo 2

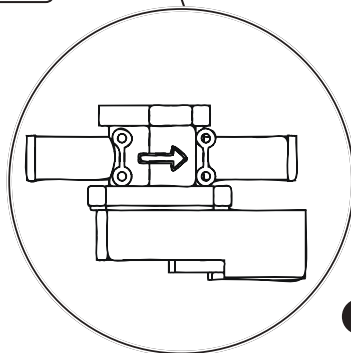

Figure 1

NOTE: Flow Direction Follows Molded Arrow on Valve



www.vintageair.com

A/C Hose Installation

1. Locate the #8 A/C hose.
2. With properly lubricated #8 O-rings (See Lubricating O-rings & Fitting Torque Specs, Page 16), loosely install the hose end with the 90° fitting onto the corresponding port on the rear of the A/C compressor, then connect the hose end with the straight fitting to the previously installed #8 condenser hardline as shown in Photo 1, below. Tighten fittings.
3. Identify the #10 A/C hose.
4. Route the hose end with the 135° fitting from the driver side of the engine bay to the passenger side bypassing the hose under the engine directly behind the compressor.
5. With a properly lubricated #10 O-ring (See Lubricating O-rings & Fitting Torque Specs, Page 16), connect the hose end with the 90° fitting to the corresponding port on the rear of the A/C compressor (See Photo 2, below). Leave loose.
6. Route the #10 A/C hose in front of the passenger-side motor mount to frame the rail toward the firewall.
NOTE: Secure the hose to the motor mount and ensure it is free and clear of any moving parts on the steering rack or suspension (See Photo 3, below). Depending on your vehicle's configuration, the #6 A/C hose can also be secured using an Adel clamp (not included) on the motor mount (See Photo 4, below).
7. Locate the #6 A/C hose.
8. With a properly lubricated #6 O-ring (See Lubricating O-rings & Fitting Torque Specs, Page 16), connect the hose end with service port to the open end of the drier and route the hose through the core support. Adjust the fitting so there is no contact with the core support to prevent chafing and tighten (See Photos 5 and 6, below).

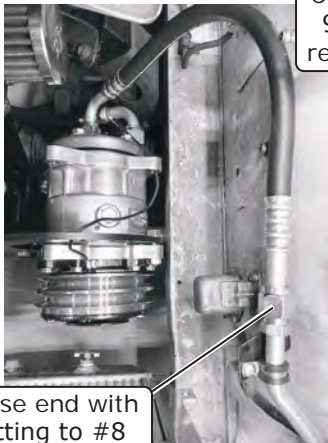

Connect hose end with straight fitting to #8 condenser hardline

Photo 1

Connect hose end with 90° fitting to port on rear of A/C compressor



Photo 2

Ensure hose is free and clear of any moving parts on steering rack or suspension



Photo 3

#6 A/C hose can also be secured using an Adel clamp (not supplied)



Photo 4

Adjust fitting so there is no contact with core support



Photo 5



Photo 6

A/C Hose Installation (Cont.)

9. Route the #6 and #10 A/C hoses together along the frame rail toward the firewall, secure with the provided tie wraps (See Photos 7 and 8, below).
10. Install the provided 1 1/4" with 3/8" hole grommet and large grommet onto the #6 and #10 A/C hoses as shown in Photo 9, below.
11. The #10 A/C hose will need to be situated as shown in Photo 10, below, to fit through the hole on the firewall.
12. Route the hoses through the previously drilled holes on the firewall then secure the grommets (See Photos 11 and 12, below).

Route #6 and #10 A/C hoses together along frame rail

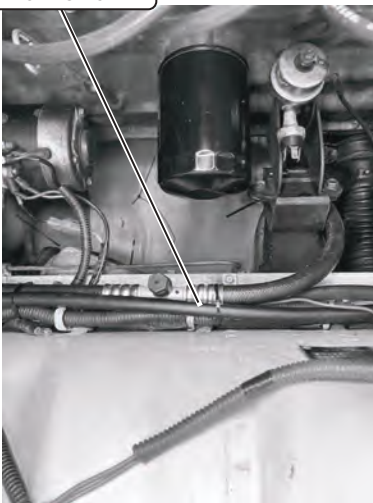

Photo 7

Secure with tie wraps



Secure with tie wraps

Photo 8

Large Grommet

1 1/4" with 3/8" Hole Grommet

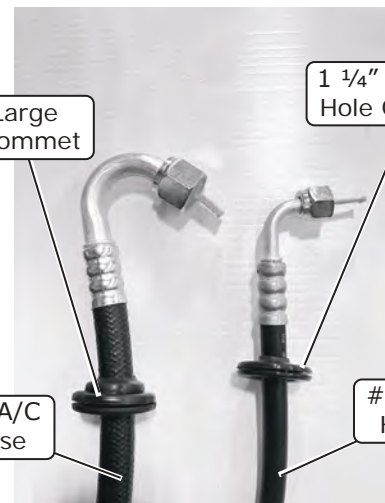

#8 A/C Hose

#6 A/C Hose

Photo 9

#10 A/C hose will need to be situated as shown



Photo 10



Route hoses through previously drilled holes on firewall

Photo 11

Secure grommets



Photo 12



www.vintageair.com

A/C Hose Installation (Final)

13. Once the hoses are installed through the firewall immediately recap the #10 A/C hose to keep it free of debris and moisture (See Photo 13, below).
14. Route the #6 A/C hose up behind the evaporator module and with a properly lubricated #6 O-ring (See Lubricating O-rings & Fitting Torque Specs, Page 16), connect it to the corresponding port on top of the evaporator module (See Photo 14, below).
15. Route the #10 A/C hose up behind the evaporator module and with a properly lubricated #10 O-ring (See Lubricating O-rings & Fitting Torque Specs, Page 16), connect it to the corresponding port on top of the evaporator module (See Photo 15, below). Be sure the #10 fitting is not pressed against the #6 fitting at the evaporator module when tightened.
16. Apply provided press tape to #10 line and fitting (See Photo 16, below).
17. With the (2) supplied 11" tie wraps, restrain both #10 and #6 hoses together nearest to the rear blower motor area (See Photo 17, below). **NOTE: Evenly space tie wraps about 5" apart. Pull enough hose slack into the passenger compartment to sweep low and immediately up to avoid contact with rear heater hardlines.**



Once hoses are installed, recap #10 A/C hose immediately to keep free of debris and moisture

Photo 13

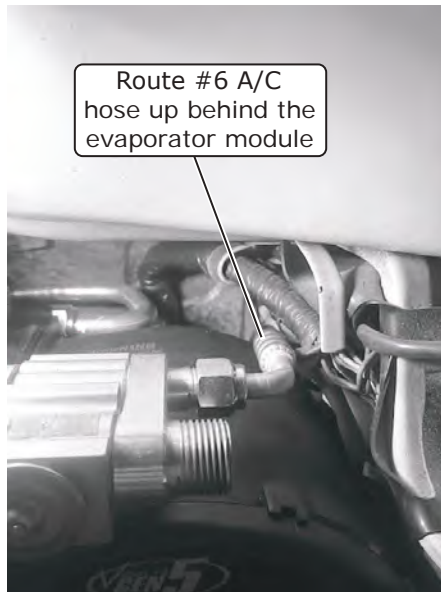

Route #6 A/C hose up behind the evaporator module

Photo 14



Route #10 A/C hose up behind the evaporator module

Photo 15

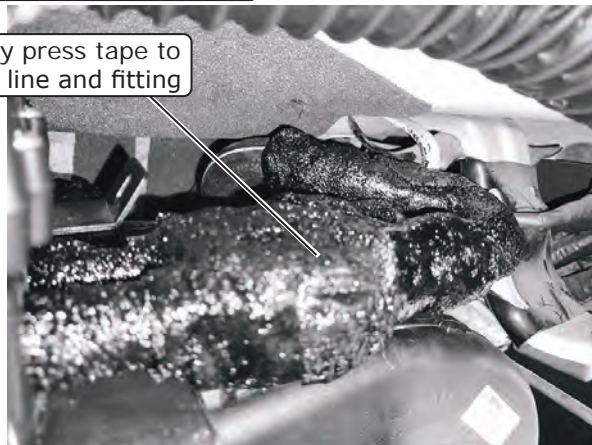

Apply press tape to #10 line and fitting

Photo 16



Restrain both #10 and #6 hoses together with supplied 11" tie wraps

Photo 17



www.vintageair.com

Wiring

1. Select a suitable ground location for the white ground wire eyelet from the heater control valve harness (See Figure 1, below) and secure it using a #12 x 1/2" self-tapping screw.
2. Route the violet power wire to a switched 12v power source.
3. Connect the tan wire to the factory dash lights to enable control panel backlighting (if applicable).
4. Connect the main harness to the ECU (See Figure 2, below).
5. Select a suitable mounting location for the main relay.
6. Connect the violet/yellow/white twisted branch with 3-position connector into the heater control valve connector (See Figure 1, below). Ensure that the mating latch is fully seated.
7. From the underside of the evaporator module, locate the twisted bundle of green and orange strand wires joined together with a connector (See Photo 1, below). Locate the color matching twisted bundle wires from the main harness nearest to the ECU connector and connect both connectors together (See Photo 2, below).

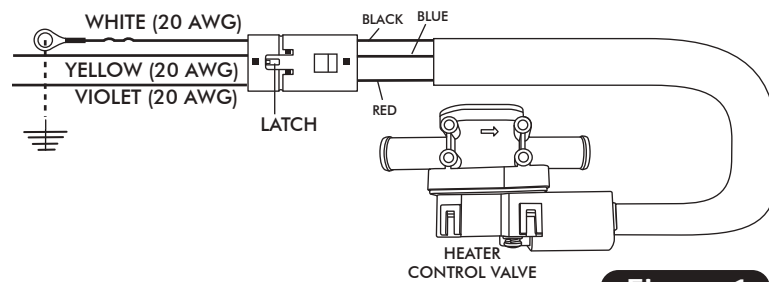

Figure 1

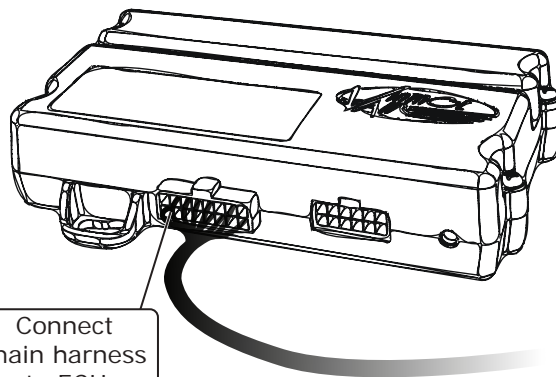

Figure 2

Locate twisted bundle of green and orange strand wires joined together with a connector

Locate color matching twisted bundle wires from main harness nearest to ECU connector and connect both connectors together

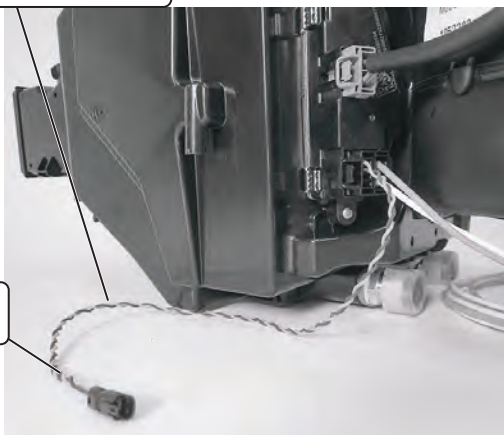

Photo 1



Photo 2



www.vintageair.com

Fast Idle Control Device (A/C Idle-Up)

NOTE: The following steps are optional to retain the use of the OEM Fast Idle Control Device (FICD). This allows the vacuum solenoid to open and engage the FICD and raise engine RPMs when the compressor clutch is engaged. Only one solenoid will be used. See Page 37, for FICD Vacuum & Wiring Diagram.

1. Locate the OEM vacuum solenoids on the passenger-side shock tower (See Photo 1, below).
2. Route vacuum lines as such: Engine Manifold > Check Valve > Vacuum Reservoir > Solenoid > FICD (See Photo 2, below). **NOTE: Bracket was removed for illustration purposes.**
3. Cut wires from the solenoid approximately 4" long (See Photo 2, below).
4. Terminate the black wire to a good ground source.
5. Splice a length of 16 GA wire to the blue solenoid wire and route toward the safety switch. Terminate the wire on the compressor side of the safety switch (See Photo 4, below).

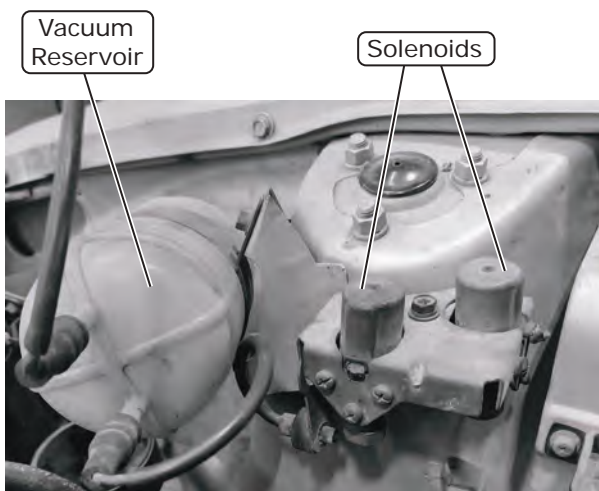

Photo 1

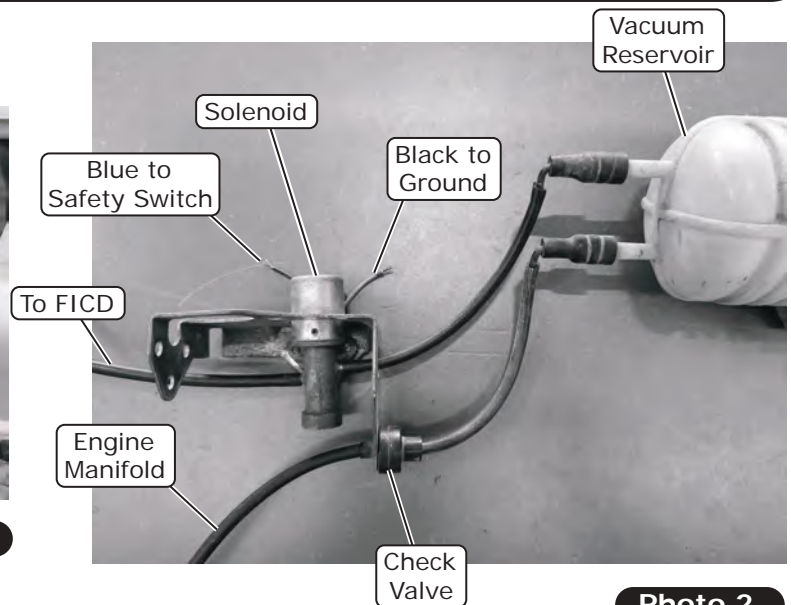

Photo 2

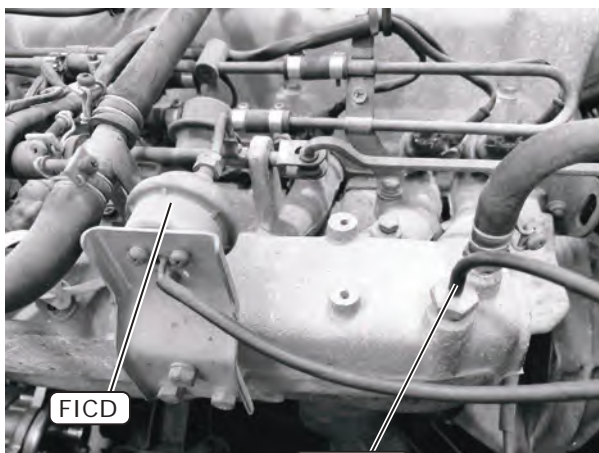

Photo 3

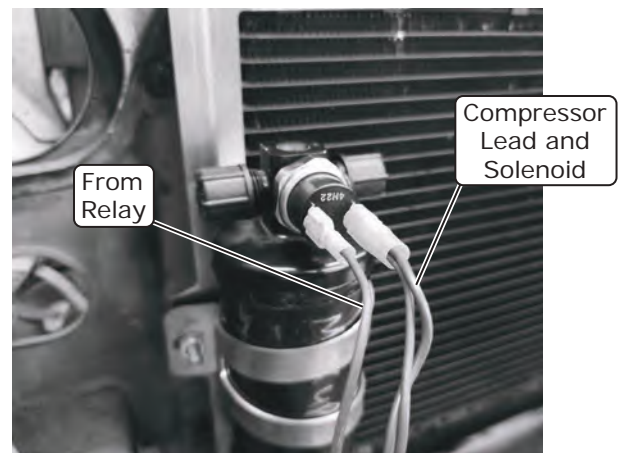
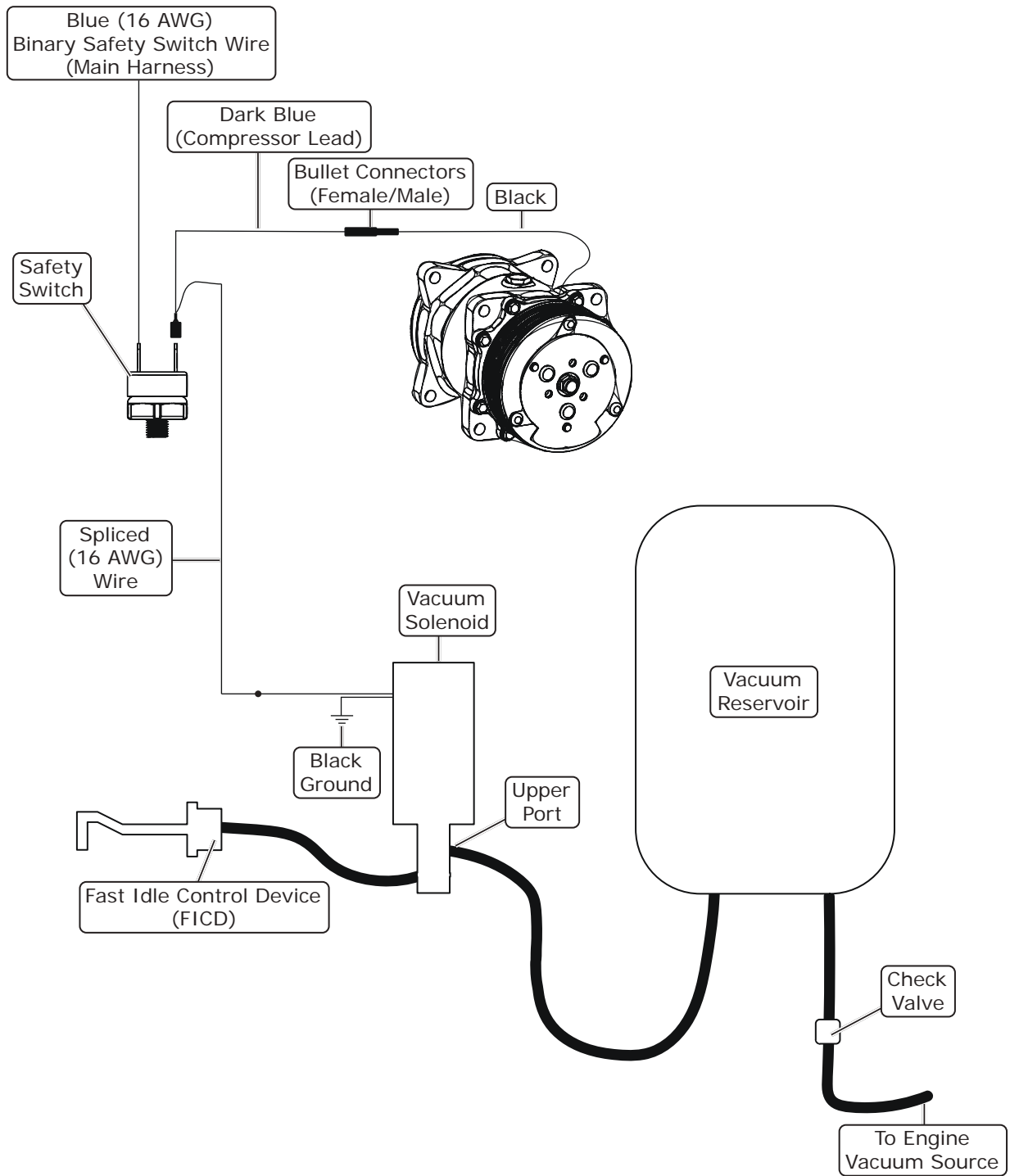

Photo 4



www.vintageair.com

FICD Vacuum & Wiring Diagram





www.vintageair.com

Engine Compartment Wiring

NOTE: The following connections are critical to the performance of the system. Before making connections, refer to the Quality Crimp Guidelines, Page 43.

1. Route power and ground wires toward the battery (See Photo 1, below).
2. Install the supplied heat shrink over the 12 AWG orange standard fuse holder assembly wire and crimp it to the 12 AWG orange wire from the main wiring harness (See Photo 2, below). Slide the heat shrink over the crimp, then apply heat.
3. Install the supplied heat shrink over the 16 AWG black mini fuse holder assembly wire and crimp it to the 16 AWG red wire from the main wiring harness (See Photo 3, below). Slide the heat shrink over the crimp, then apply heat.
4. Install the fuses into the holders (See Photos 4 and 5, below).
5. Install the supplied heat shrink over the white ground wires, then crimp on the supplied ring terminals (See Photo 6, below). Slide the heat shrink over the crimps, then apply heat. **NOTE: Both white wires can be crimped to the larger ring terminal. Install the heat shrink, then strip the wires, twist them together and trim to length. Crimp on the ring terminal, then slide the heat shrink over and apply heat (See Photos 7 and 8, below).**

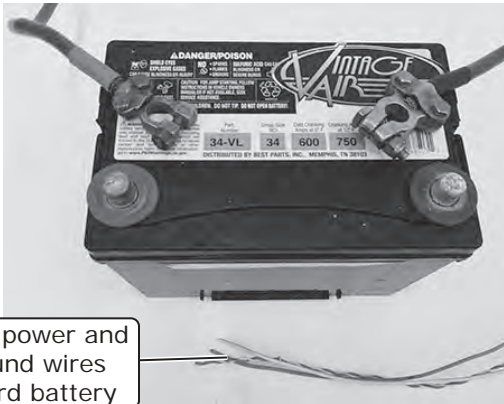

Route power and ground wires toward battery

Photo 1

Crimp 12 AWG orange fuse holder wire to 12 AWG orange wire from main wiring harness



Photo 2

Install heat shrink over 12 AWG orange standard fuse holder assembly wire

Crimp 16 AWG black fuse holder wire to 16 AWG red wire from main wiring harness



Photo 3

Install heat shrink over 16 AWG black standard fuse holder assembly wire

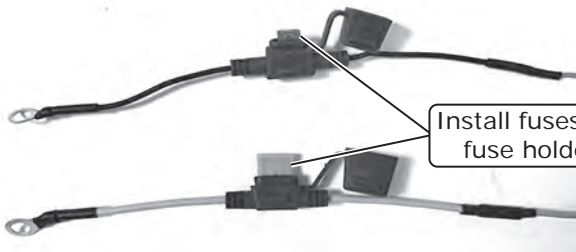

Install fuses into fuse holders

Photo 4



Both white ground wires can be crimped together. Install heat shrink, then strip wires, twist together and trim to length.

Photo 5

Install heat shrink over white ground wires, then crimp on ring terminals

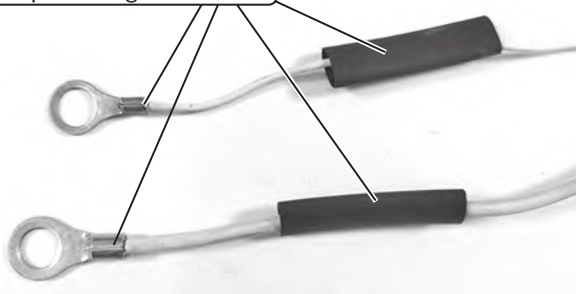

Photo 6

Crimp on ring terminal, then slide heat shrink over and apply heat



Photo 7

Photo 8



www.vintageair.com

Engine Compartment Wiring (Cont.)

6. Connect the ground wire ring terminals to the negative battery terminal connector (See Photos 9 and 10, below).
7. Connect the positive wire ring terminals to the positive battery terminal connector (See Photos 11 and 12, below). **NOTE: Do not connect power until the installation is completed.**
8. Wiring completed (See Photo 13, below).

Connect ground wire ring terminals to negative battery terminal
NOTE: Either connection application can be used.

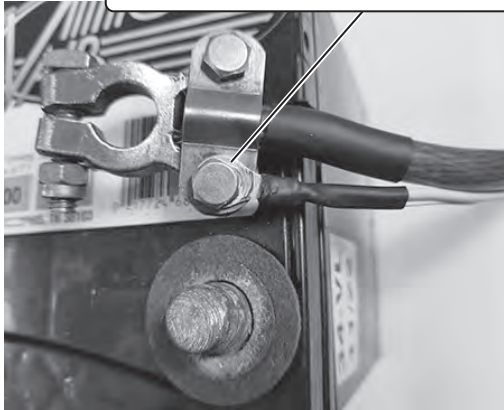

Photo 9



Photo 10

Connect power wire ring terminals to positive battery terminal
NOTE: Either connection application can be used.

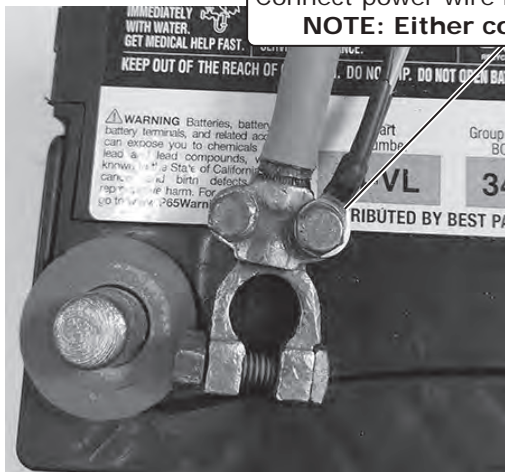
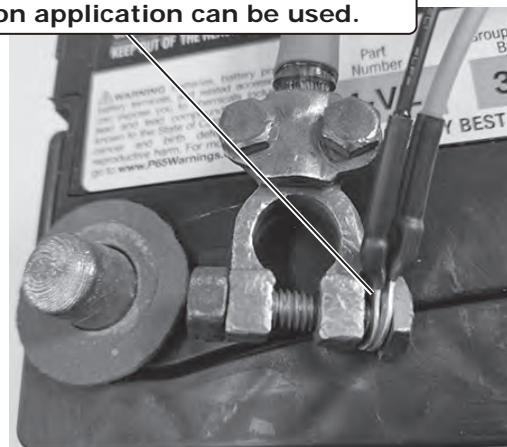

Photo 11



NOTE: Do not connect power until installation is completed.

Photo 12



Completed Installation Shown

Photo 13



www.vintageair.com

Final Steps: Installation Check

Installation Check	
ITEM TO CHECK	Procedure
<input type="checkbox"/>	<p>ECU</p> <p>If no blinking is observed after 1 minute of turning the ignition on, go to the next check.</p> <p>If repetitive blinking is observed, go to the Advanced Diagnostics Section to diagnose.</p>
<input type="checkbox"/>	<p>Blower speed control</p> <p>Set the blower speed control to OFF, <u>confirm that the blower is off</u>.</p> <p>Position the blower speed control to LOW then MEDIUM and then HIGH. <u>At each setting confirm that the blower speed increases</u>, do this by feeling for the amount of air coming from the unit and hearing the blower speed increase.</p>
<input type="checkbox"/>	<p>Mode control</p> <p>Set the MODE control to the DASH position. <u>Confirm that air is being blown at the dash vents.</u></p> <p>Set the MODE control to the FLOOR position. <u>Confirm that air is being blown at the floor vents.</u></p> <p>Set the MODE control to the DEFROST position. <u>Confirm that all air is being blown from the defrost vents</u></p> <p>If heater lines are installed:</p> <p>Set the MODE control to the DASH position. Set the TEMP control to the MAX HEAT position. <u>Confirm that HOT air is coming from the dash vents.</u></p>
<input type="checkbox"/>	<p>Temperature control</p> <p>If system is charged:</p> <p>Set the TEMP control to the MAX COOL position. <u>Confirm that COLD air is coming from the dash vents.</u></p> <p>Also <u>confirm that the compressor "clicks" on</u> when adjusting the TEMP control from the MAX HEAT position to the MAX COOL position.</p>
<input type="checkbox"/>	<p>AC Indicator (If applicable)</p> <p>While the MODE control is set to the DASH position, and the TEMP control is set to the MAX COOL/MIN HEAT position, <u>confirm that the blue AC Indicator light is on</u>.</p>
<input type="checkbox"/>	<p>Backlight (If applicable)</p> <p>If your control panel has backlight capabilities and has been wired, turn the dash lamp on and <u>confirm that the AC panel's legend is lit</u>.</p>
<input type="checkbox"/>	<p>Fittings</p> <p>Verify AC and Heater fittings are all tight.</p>



www.vintageair.com

Final Steps: Completing the Install

1. Install duct hoses as shown in Duct Hose Routing, Page 42.
2. Route A/C wires (12 volt/grounds/binary switch/heater valve) through 3/8" grommet.
3. Install control panel assembly. Refer to control panel instructions.
4. Plug the wiring harnesses into the ECU module on the sub case. Wire according to wiring diagrams on Pages 45 and 46.
5. Install glove box as shown in Glove Box Installation, Page 43.
6. Reinstall all previously removed items.
7. Fill radiator with at least a 50/50 mixture of approved antifreeze and distilled water. It is the owner's responsibility to keep the freeze protection at the proper level for the climate in which the vehicle is operated. Failure to follow antifreeze recommendations will cause heater core to corrode prematurely and possibly burst in A/C mode and/or freezing weather, voiding your warranty.
8. Double check all fittings, brackets and belts for tightness.
9. Vintage Air recommends that all A/C systems be serviced by a licensed automotive A/C technician.
10. Evacuate the system for a minimum of 45 minutes prior to charging, and perform a leak check prior to servicing.
11. Charge the system to the capacities stated on Page 4 of this instruction manual.
12. See Operation of Controls procedures on Page 47.



www.vintageair.com

Duct Hose Routing

NOTE: For the system to function optimally, the duct hoses must be routed as directly as possible, taking care to avoid kinks, sharp bends and unnecessary length. Vintage Air supplies duct hoses in continuous lengths that will need to be cut to size depending on application. Before cutting, familiarize yourself with the installation instructions and verify the routing will work with your application. For custom hose routing, additional hose may be needed and can be purchased from Vintage Air.

1. Stretch the duct hose until there is no slack, measure, mark and cut hose to size (See Photo 1, below).

Stretch, measure, mark and cut hose to size



Photo 1

Disclaimer: Before cutting duct hose to length, verify the routing will work for your application.

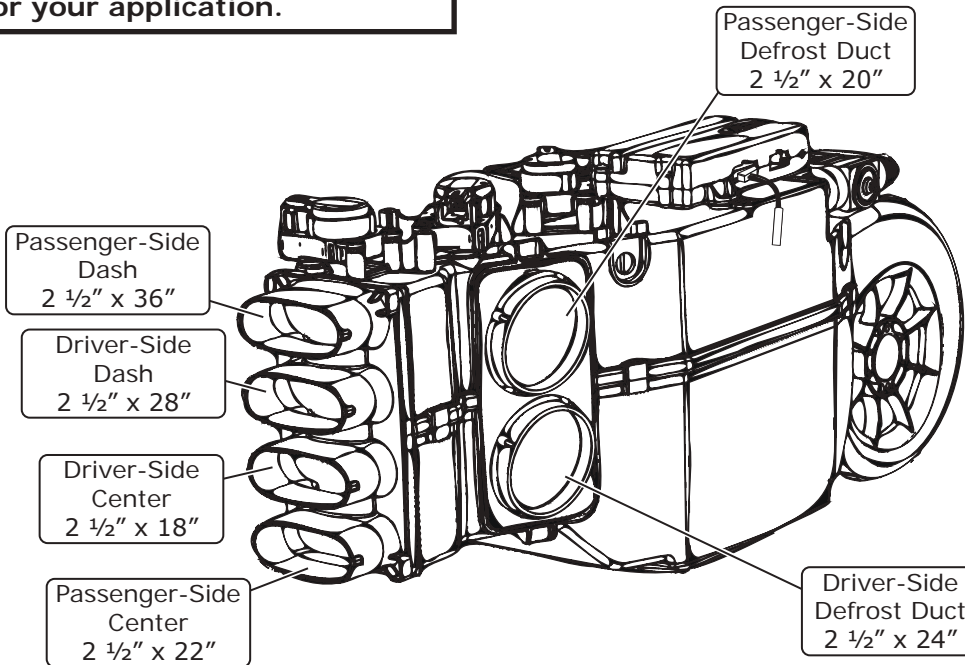

NOTE: ECU must be placed away from water and humidity, and also be accessible for servicing. If relocating, connectors must be positioned towards the bottom.

Position connectors towards bottom



www.vintageair.com

Glove Box Installation

1. Measure and mark the glove box 2 1/2" above the molding line all the way around the glove box (See Photo 1, below).
2. Cut the glove box along the marked line (See Photos 1 and 2, below).
3. Install (6) S-clips around the cut edge of the glove box with the clip bodies on the outside as shown in Photo 3, below.
4. Install the cap onto the glove box, firmly pressing onto all S-clips (See Photo 4, below).
5. Reinstall the glove box, latch catch, and door arm using OEM hardware (See Photo 5, below).

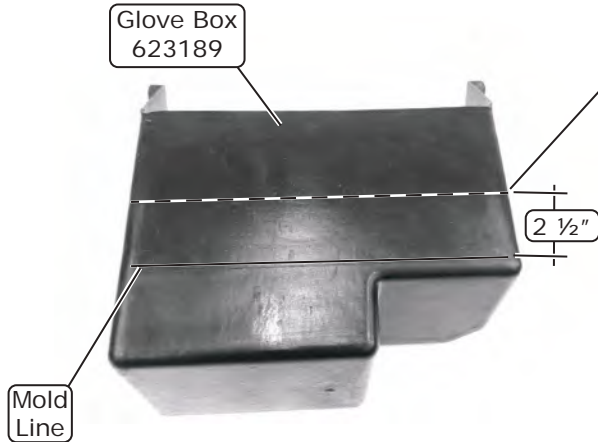

Photo 1

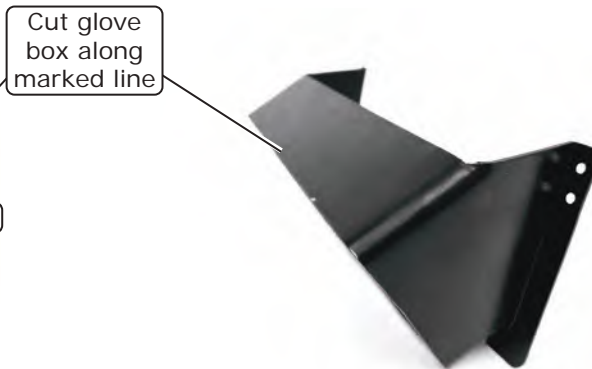
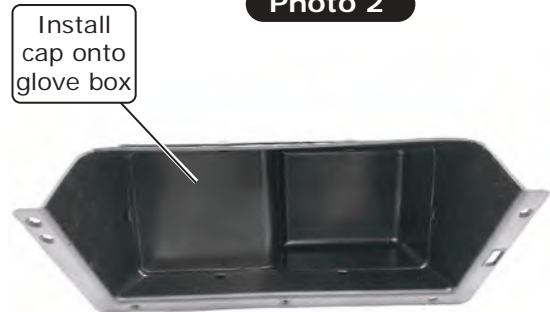

Photo 2



Install (6) S-clips around cut edge of glove box

Photo 3



Install cap onto glove box

Photo 4



Installation Complete

Photo 5

Quality Crimp Guideline

Acceptable strip length
(Some copper visible)

Crimped area is centered
on each side of splice

Bad strip length
(Too much copper visible)
Visible copper should be
just enough to ensure
clearance between splice
area and wire insulation

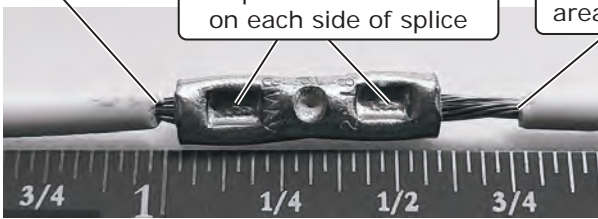

Photo 1

A good crimp requires
seam of butt splice to be
opposite of crimp die tooth

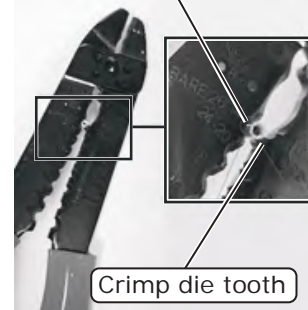

Photo 2

Good Ring Terminal Crimp

Bad Ring Terminal Crimp



Crimped
area is
opposite
of seam

Photo 3

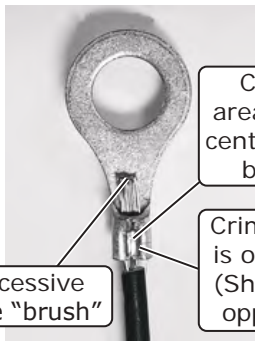

Crimp
area is not
centered on
barrel

Excessive
wire "brush"

Crimp
area is
on seam
(Should be
opposite)

Photo 4

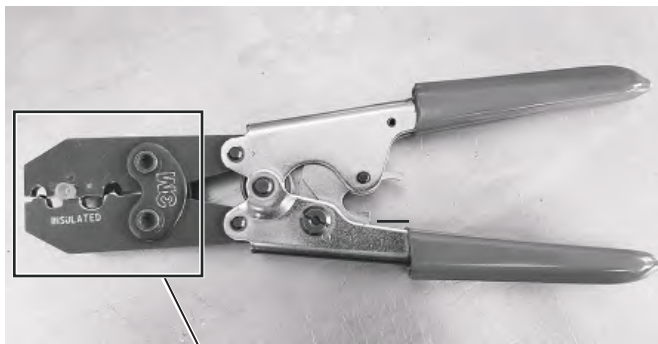

Photo 5

Crimp
area is
centered
on barrel

Use a ratcheting crimp tool
for insulated barrel terminals
when crimping the provided
female insulated terminal.
Ensure terminal is inserted in
appropriate position before
crimping.

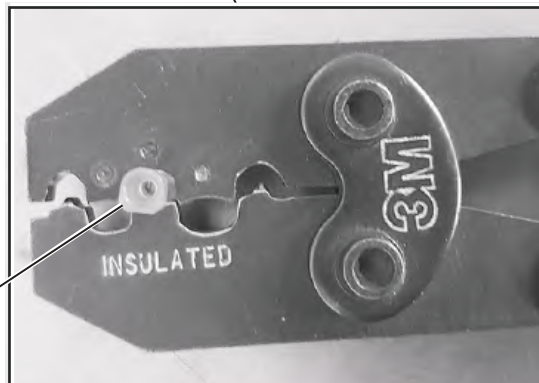
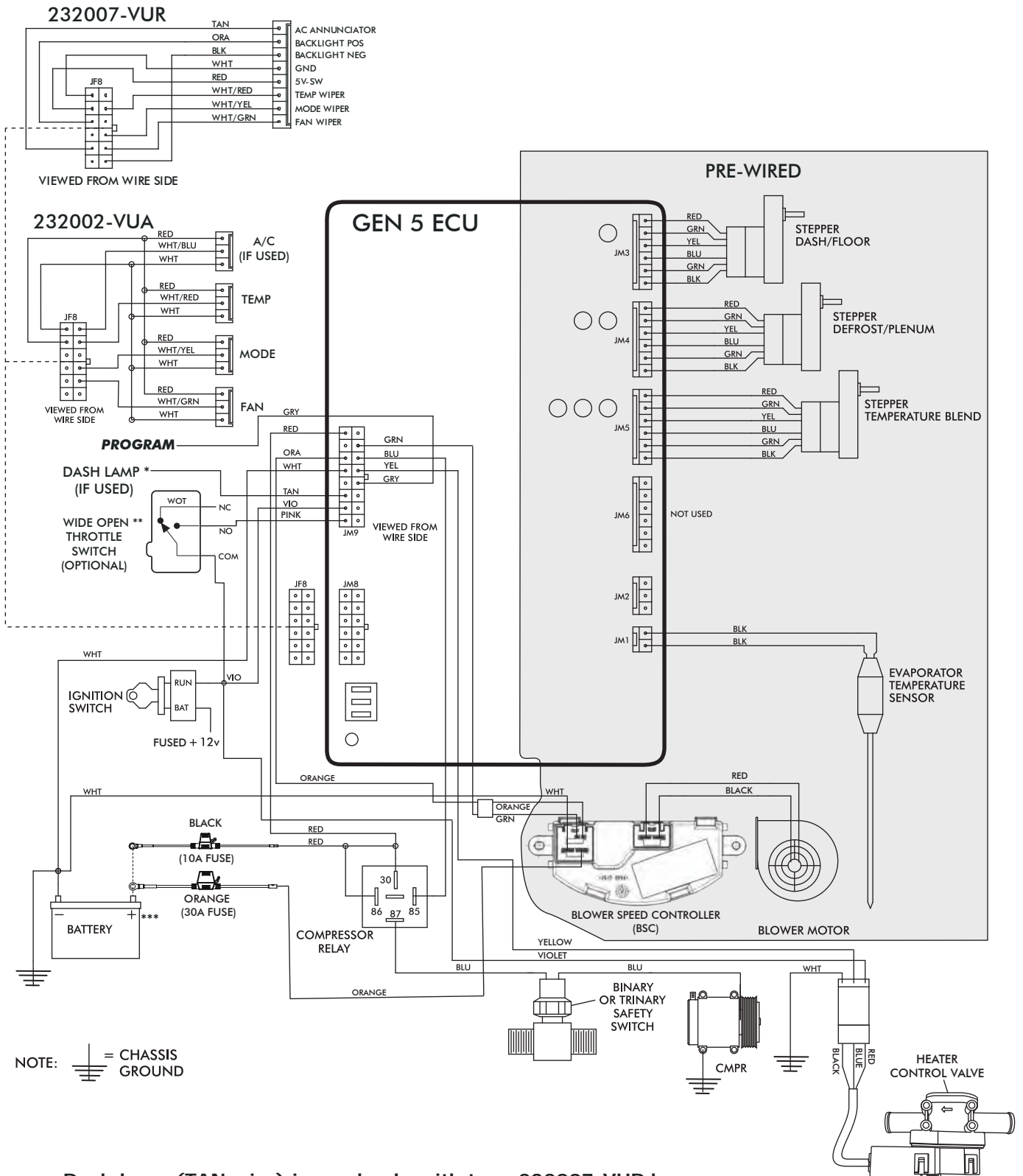

Photo 5a



www.vintageair.com

Gen 5 Wiring Diagram



NOTE: = CHASSIS GROUND

- * Dash lamp (TAN wire) is used only with type 232007-VUR harness.
- ** Wide open throttle switch contacts close only at full throttle, which disables A/C compressor.
- *** Install fuse assemblies at or as near to the battery as possible.



www.vintageair.com

Gen 5 Wiring Instructions

WIRING HARNESS (231505) ↓

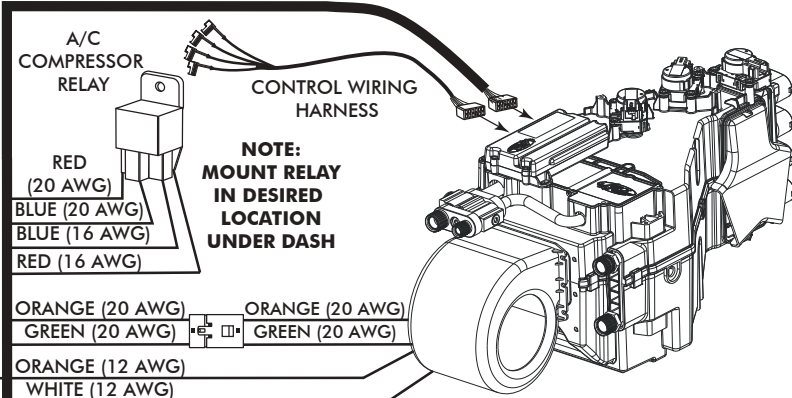

NOTE:
MOUNT RELAY
IN DESIRED
LOCATION
UNDER DASH

Ignition Switch:
Using provided butt splice (PN 226004), connect the 20 AWG violet wire to a 5A fused and switched 12V source such as Key On.

Wide Open Throttle Switch (Optional):
If a wide open throttle switch is required, connect the 20 AWG pink wire to a normally open switch that, when closed, connects a fused and switched 12V source to the pink wire. See Gen 5 wiring diagram for an example.



Dash Light (Optional):
If using a Vintage Air control panel with back light, connect the 20 AWG tan wire to the vehicle's dash back light 0-12V using provided butt splice (PN 226004).

WIRING HARNESS (232020) →

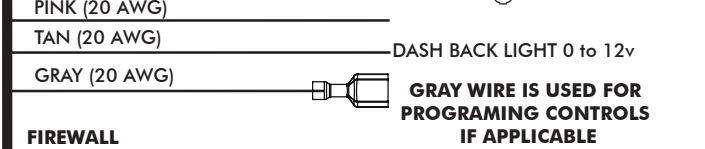

Heater Control Valve:
Connect the Violet/Yellow/White twisted branch with 3 position connector into the heater control valve connector. Ensure that the mating latch is fully seated.

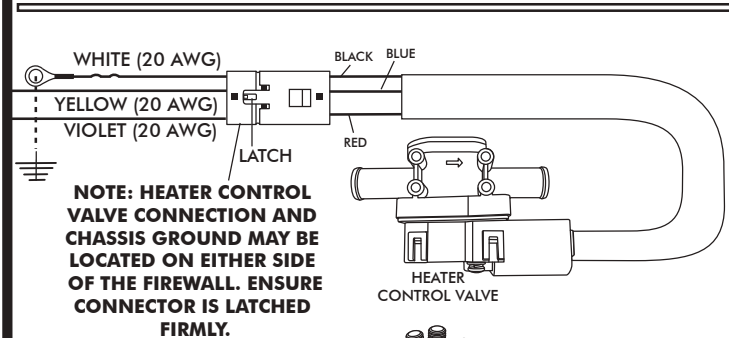

Binary/Trinary & Compressor:
Binary Switch: Terminate provided insulated female terminal (PN 23172-VUW) to the blue 16 AWG wire. Connect as shown.
Trinary Switch: Connect according to trinary switch wiring diagram.

WIRING HARNESS (232020) →

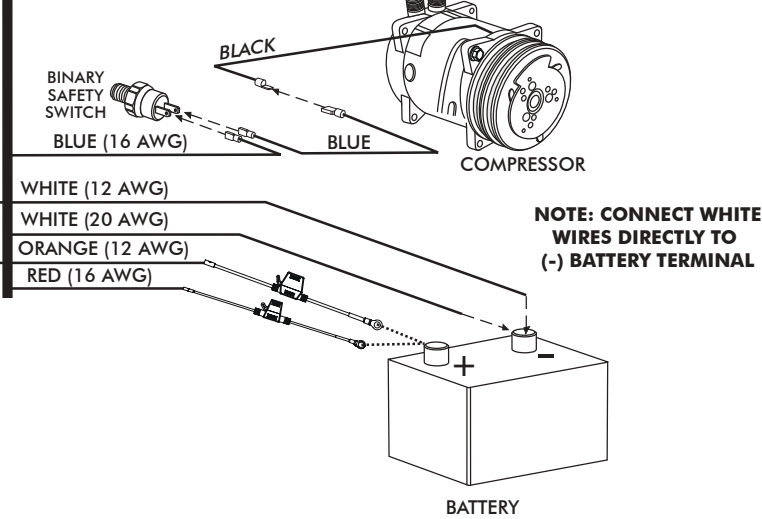

Battery Connections:
ECU Ground: Terminate provided ring terminal (PN 226110) to 20 AWG white wire from the 231505 wire assembly and install at battery.
ECU PWR: Terminate provided fuse assembly with black leads (PN 233012) to the 16 AWG red wire from the 231505 wire assembly. Install provided 10A Red Mini Fuse (PN 226118). Install at battery.
Blower Speed Controller (BSC) Ground: Terminate provided ring terminal (PN 226111) to 12 AWG white wire from the 232020 wire assembly and install at battery.
Blower Speed Controller (BSC) PWR: Terminate provided fuse assembly with orange leads (PN 233008) to the 12 AWG orange wire from the 232020 wire assembly. Install provided 30A Green ATO/ATC Fuse (PN 226125). Install at battery.



www.vintageair.com

Operation of Controls

On Gen IV or Gen 5 systems with three lever/knob controls, the temperature control toggles between heat and A/C operations. To activate A/C, move the temperature lever/knob all the way to cold and then back it off to the desired vent temperature. For heat operation, move the temperature lever/knob all the way to hot and then adjust to the desired vent temperature. The blower will momentarily change speed, each time you toggle in and out of heat and A/C operations, to indicate the change.

Blower Speed

This lever/knob controls blower speed, from OFF to HI.

Mode Control

This lever/knob controls the mode positions, from DASH to FLOOR to DEFROST, with a blend in between.

Temperature Control

This lever/knob controls the temperature, from HOT to COLD.

Blower Speed



Mode Control

Temperature Control

A/C Light
(When Lit, Compressor is Engaged)

A/C Operation

Blower Speed

Adjust to desired speed.

Mode Control

Adjust to desired mode position (DASH position recommended).

Temperature Control

For A/C operation, adjust to coldest position to engage compressor (Adjust between HOT and COLD to reach desired temperature).



Heat Operation

Blower Speed

Adjust to desired speed.

Mode Control

Adjust to desired mode position (FLOOR position recommended).

Temperature Control

For maximum heating, adjust to hottest position (Adjust between HOT and COLD to reach desired temperature).

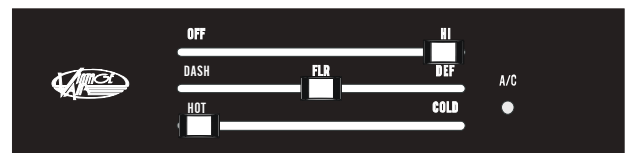

Defrost/De-fog Operation

Blower Speed

Adjust to desired speed.

Temperature Control

Adjust to desired temperature.

Mode Control

Adjust to DEFROST position for maximum defrost, or between FLOOR and DEFROST positions for a bi-level blend (Compressor is automatically engaged).





www.vintageair.com

Troubleshooting Guide

This printed troubleshooting guide is our basic guide that covers common installation problems. To see our advanced diagnostics and troubleshooting guide, please refer to the following page for instructions on how to download the complete guide.

WARNING: While troubleshooting the system, never probe connector terminals from the front mating side, only back probe.

WARNING: While troubleshooting the system, never use automotive check lights.

Symptom	Condition	Checks	Actions	Notes
1. Blower stays on high speed with ignition on.	No other functions work.	Check for damaged pins or wires in the control panel wire assembly and mating header at ECU.	If found damaged, replace wire assembly or ECU.	If fuse continues to blow, there is a serious problem in the wiring. Check all wiring and ensure the wire is not damaged and shorting out along its route.
	All other functions work.	Check for a bad ECU GND. Check for damaged pins or wires in the control panel wire assembly and mating header at ECU. Check if Blower power fuse is blown. Check for a bad ECU GND.	If found damaged, replace wire assembly or ECU. Replace fuse. Repair connection.	
2. Compressor will not turn on (All other functions work).	System is not charged.	System must be charged for compressor to engage.	Charge system.	Danger: Never bypass safety switch with engine running. Serious injury can result. To check for proper pot function, check voltage at white/red wire. Voltage should be between 0V and 5V, and will vary with pot lever position. Disconnected or faulty thermistor will cause compressor to be disabled.
		Check for faulty A/C potentiometer or associated wiring (not applicable to 3-pot controls).	Check continuity to ground on white control head wire. Check for 5V on red control head wire.	
	System is charged.	Check for disconnected or faulty thermistor.	Check 2-pin connector at ECU housing.	
3. Compressor will not turn off (All other functions work).	Compressor will not turn off (All other functions work).	Check for faulty A/C potentiometer or associated wiring.	Repair or replace pot/control wiring.	Red wire at A/C pot should have approximately 5V with ignition on. White wire will have continuity to chassis ground. White/Red wire should vary between 0V and 5V when lever is moved up or down.
		Check for faulty A/C relay.	Replace relay.	



www.vintageair.com

Troubleshooting Guide (Cont.)

Symptom	Condition	Checks	Actions	Notes
4. System will not turn on, or runs intermittently.	Works when engine is not running; shuts off when engine is started	Noise interference from either ignition or alternator.	Install capacitors on ignition coil and alternator. Ensure good ground at all points. Relocate coil and associated wiring away from ECU and ECU wiring. Check for burned or loose plug wires.	Ignition noise (radiated or conducted) will cause the system to shut down due to high voltage spikes. If this is suspected, check with a quality oscilloscope. Spikes greater than 16V will shut down the ECU. Install a radio capacitor at the positive post of the ignition coil (see radio capacitor installation bulletin). A faulty alternator or worn out battery can also result in this condition.
	Will not turn on under any conditions.	Verify connections on power lead, ignition lead, and both white ground wires. Verify battery voltage is greater than 10 volts and less than 16 while engine is running.	Check for power at ECU, and confirm ignition is being applied to ECU properly. Verify proper meter function by checking the condition of a known good battery.	
5. Loss of mode door function.	No mode change at all.	Check for damaged mode switch or potentiometer and associated wiring.		
	Blower turns on and off rapidly.	Battery voltage is at least 12V. Battery voltage is less than 12V.	Ensure all system grounds and power connections are clean and tight. Charge battery.	System shuts off blower at 10V. Poor connections or weak battery can cause shutdown at up to 11V.
7. Erratic functions of blower, mode, temp, etc.		Check for damaged switch or pot and associated wiring.	Repair or replace.	

Advanced Diagnostics and Troubleshooting Guide

If after referencing the Troubleshooting Guide, the issue is not resolved, move to The Advanced Diagnostics and Troubleshooting Guide that covers the following:

- **ECU Diagnostics Codes**
- 1. **ECU Blink Sequence**
- 2. **Firmware Version Number**
- 3. **ECU Model Number**
- 4. **ECU Start-Up Blink Sequence**
- 5. **Diagnostic Codes**
- **Complete Advanced Troubleshooting Guidelines**

Access the latest version of the Advanced Diagnostics and Troubleshooting Guide by scanning the following QR code on your mobile device:



You can also access the guide by typing the following address into your web browser:

https://www.vintageair.com/instructions_pdf/905000.pdf



www.vintageair.com

Packing List: Evaporator Kit (589026)

No.	Qty.	Part No.	Description
1.	1	765200	Gen 5 Magnum Max Module with 404 ECU
2.	1	789026	Accessory Kit

Checked By: _____
Packed By: _____
Date: _____

1



Gen 5 Magnum Max
Module with 404 ECU
765200

2

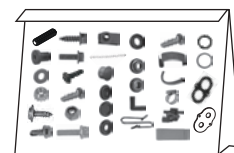
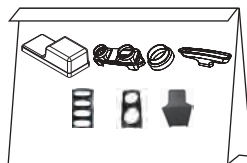
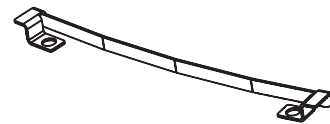
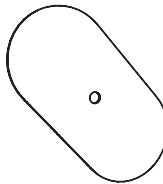
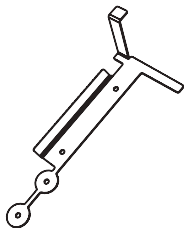
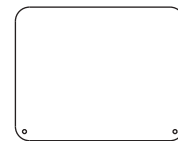
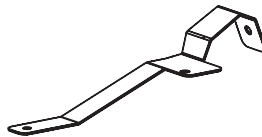
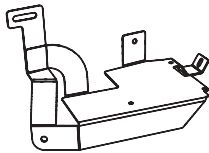
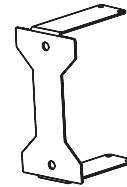
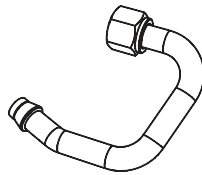

Accessory Kit
789026

**NOTE: Images may not depict actual parts and quantities.
Refer to packing list for actual parts and quantities.**