



1970-73 Datsun 240Z

**Gen 5 Evaporator Kit
(589025)**



18865 Goll St. San Antonio, TX 78266
Phone: 800-862-6658
Sales: sales@vintageair.com
Tech Support: tech@vintageair.com
www.vintageair.com



www.vintageair.com

Table of Contents

Cover.....	1
Table of Contents.....	2
Packing List/Parts Disclaimer.....	3
Information Page.....	4
Wiring Notice.....	5
Engine Compartment Disassembly, Condenser Assembly and Installation, Compressor and Brackets.....	6
Dash Overview & Exterior Disassembly.....	7
Blower & Center Console Finisher Disassembly.....	8
Heater Core Disassembly & Removal.....	9
Firewall Modification and Fresh Air Cap Installation.....	10-11
Wiring Harness Installation.....	12
Heater Ports Grommet Install & Hose Preparation, Defrost Duct & Dash Vent Adapters Installation.....	13
Defrost Duct & Dash Vent Adapters Installation (Cont.).....	14
Defrost Duct & Dash Vent Adapters Installation (Final).....	15
Center Louver Housing Adapter Installation, Lubricating O-rings & Fitting Torque Specs.....	16
Properly Seated O-ring Land, Evaporator Preparation & Installation.....	17
Evaporator Preparation & Installation (Cont.).....	18-21
Drain Hose and Grommet Installation.....	22
Heater Control Valve Installation.....	23
A/C Hose Installation.....	24-26
A/C and Heater Hose Routing.....	27
Wiring.....	28
Engine Compartment Wiring.....	29-30
Final Steps: Installation Check.....	31
Final Steps: Completing the Install.....	32
Duct Hose Routing.....	33
Glove Box Installation.....	34
Quality Crimp Guideline.....	35
Gen 5 Wiring Diagram.....	36
Gen 5 Wiring Connection Instruction.....	37
Operation of Controls.....	38
Troubleshooting Guide.....	39
Troubleshooting Guide (Cont.), Advanced Diagnostics and Troubleshooting Guide.....	40
Packing List.....	41



www.vintageair.com

Packing List: Evaporator Kit (589025)

No.	Qty.	Part No.	Description
1.	1	765200	Gen 5 Magnum Max Module with 404 ECU
2.	1	789025	Accessory Kit

**** Before beginning installation, open all packages and check contents of shipment. Please report any shortages directly to Vintage Air within 15 days. After 15 days, Vintage Air will not be responsible for missing or damaged items.**

1



**Gen 5 Magnum Max
Module with 404 ECU
765200**

2

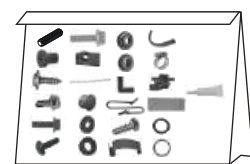
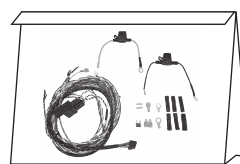
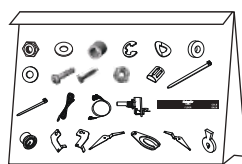
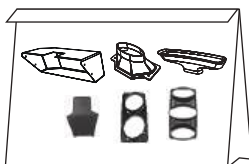
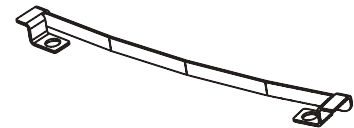
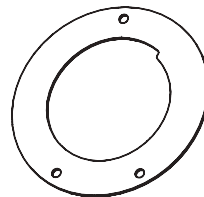
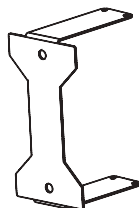
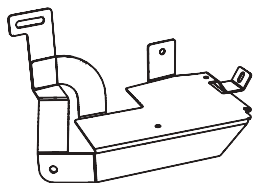
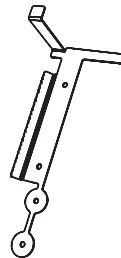
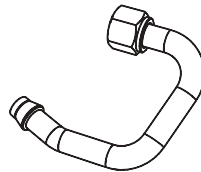

**Accessory Kit
789025**

NOTE: Images may not depict actual parts and quantities. Refer to packing list for actual parts and quantities.



www.vintageair.com

Important Notice—Please Read

For Maximum System Performance, Vintage Air Recommends the Following:

NOTE: Vintage Air systems are designed to operate with R134a refrigerant only. Use of any other refrigerant could damage your A/C system and/or vehicle, and possibly cause a fire, in addition to potentially voiding the warranties of the A/C system and its components.

Refrigerant Capacities:

Vintage Air System: 1.8 lbs. (28.8 oz.) or 816 grams of **R134a**, charged by weight with a quality charging station or scale. **NOTE: Use of the proper type and amount of refrigerant is critical to system operation and performance.**

Other Systems: Consult manufacturer's guidelines.

Lubricant Capacities:

New Vintage Air-Supplied Sanden Compressor: No additional oil needed (Compressor is shipped with proper oil charge).

All Other Compressors: Consult manufacturer (Some compressors are shipped dry and will need oil added).

Safety Switches

Your Vintage Air system is equipped with a binary pressure safety switch. A binary switch disengages the compressor clutch in cases of extreme low pressure conditions (refrigerant loss) or excessively high head pressure (406 PSI) to prevent compressor damage or hose rupture. A trinary switch combines Hi/Lo pressure protection with an electric fan operation signal at 254 PSI, and should be substituted for use with electric fans. Compressor safety switches are extremely important since an A/C system relies on refrigerant to circulate lubricant.

Service Info:

Protect Your Investment: Prior to assembly, it is critical that the compressor, evaporator, A/C hoses and fittings, hardlines, condenser and receiver/drier remain capped. Removing caps prior to assembly will allow moisture, insects and debris into the components, possibly leading to reduced performance and/or premature failure of your A/C system. This is especially important with the receiver/drier.

Additionally, when caps are removed for assembly, **BE CAREFUL!** Some components are shipped under pressure with dry nitrogen.

Evacuate the System for 35-45 Minutes: Ensure that system components (Drier, compressor, evaporator and condenser) are at a temperature of at least 85°F. On a cool day, the components can be heated with a heat gun **or** by running the engine with the heater on before evacuating. Leak check and charge to specifications.

Bolts Passing Through Cowl and/or Firewall:

To ensure a watertight seal between the passenger compartment and the vehicle exterior, for all bolts passing through the cowl and/or firewall, Vintage Air recommends coating the threads with silicone prior to installation.

Heater Hose (not included with this kit):

Heater hose may be purchased from Vintage Air (Part#31800-VUD) or your local parts retailer. Routing and required length will vary based on installer preference.



www.vintageair.com

Important Wiring Notice—Please Read

Some vehicles may have had some or all of their radio interference capacitors removed. There should be a capacitor found at each of the following locations:

- 1. On the positive terminal of the ignition coil.**
- 2. If there is a generator, on the armature terminal of the generator.**
- 3. If there is a generator, on the battery terminal of the voltage regulator.**

Most alternators have a capacitor installed internally to eliminate what is called “whining” as the engine is revved. If whining is heard in the radio, or just to be extra cautious, a radio interference capacitor can be added to the battery terminal of the alternator.

It is also important that the battery lead is in good shape and that the ground leads are not compromised. There should be a heavy ground from the battery to the engine block, and additional grounds to the body and chassis.

If these precautions are not observed, it is possible for voltage spikes to be present on the battery leads. These spikes come from ignition systems and charging systems, and from switching some of the vehicle’s other systems on and off. Modern computer-operated equipment can be sensitive to voltage spikes on the power leads, which can cause unexpected resets, strange behavior and/or permanent damage.

Vintage Air strives to harden our products against these types of electrical noise, but there is a point where a vehicle’s electrical system can be degraded so much that nothing can help.

Radio interference capacitors should be available at most auto and truck parts suppliers. They typically are cylindrical in shape, a little over an inch long and a little over a half-inch in diameter, and they have a single lead coming from one end of the cylinder with a terminal on the end of the wire, as well as a mounting clip which is screwed into a good ground on the vehicle. The specific value of the capacitance is not too significant in comparison to ignition capacitors that are matched with the coil to reduce pitting of the points.

- Care must be taken, when installing the compressor lead, not to short it to ground. The compressor lead must not be connected to a condenser fan or to any other auxiliary device. Shorting to ground or connecting to a condenser fan or any other auxiliary device may damage wiring or the compressor relay, and/or cause a malfunction.
- When installing ground leads on Gen 5 systems, the blower control ground and ECU ground must be connected directly to the negative battery post.
- For proper system operation, the heater control valve must be connected to the ECU.



www.vintageair.com

Engine Compartment Disassembly

NOTE: Before starting the installation, check the function of the vehicle (horn, lights, etc.) for proper operation, study the instructions, illustrations, photos & diagrams. Removing the vehicle's hood is not absolutely necessary to achieve full kit install, but can ease accessibility and visibility to the front core support components.

Perform the following:

1. Disconnect the negative and positive battery post cables from the vehicle's battery.
2. Drain coolant from the radiator.
3. Disconnect upper and lower radiator hoses from the radiators inlet and outlet ports.
4. Remove radiator fan and shroud.
5. Remove the (4) bolts that secure the radiator against the core support. Carefully remove the radiator from the engine compartment.
6. Disconnect the (2) heater hoses from the heater core ports on the firewall and disconnect the ends to the engine's cylinder head and water pump port

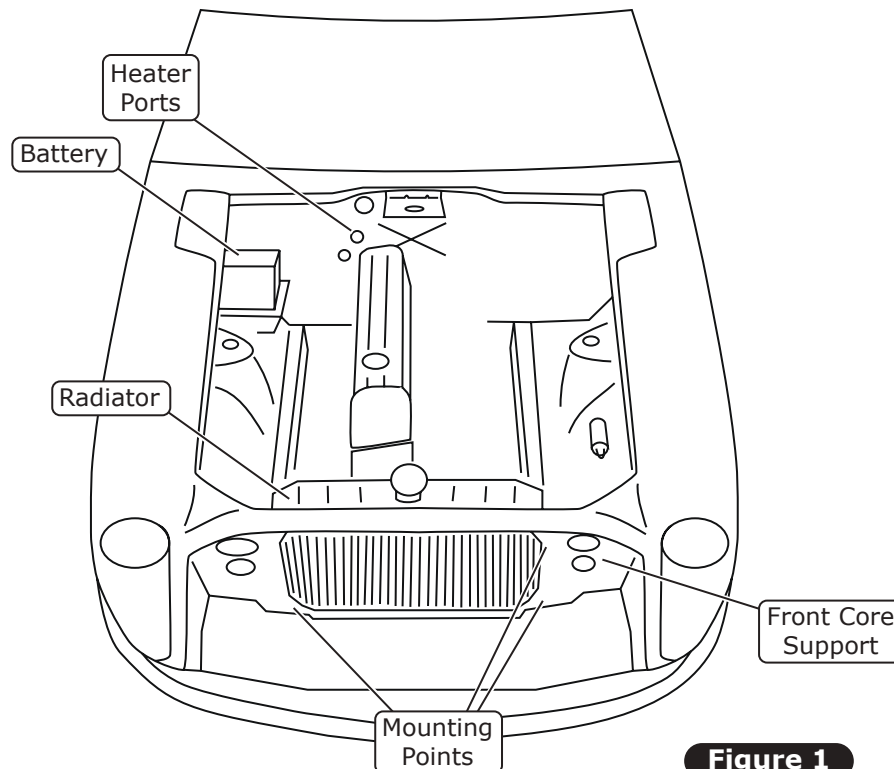

Figure 1

Condenser Assembly and Installation

1. Refer to instructions included with the condenser kit to install the condenser.
2. Binary switch installation (Refer to condenser instructions).

Compressor and Brackets

1. Refer to instructions included with the bracket kit to install the compressor bracket.



www.vintageair.com

Dash Overview & Exterior Disassembly

1. Remove the defrost vent cover by removing the (5) screws along the top of the cover (See Figure 1, below).
2. Remove the glove box door by removing the (3) screws located on the glove box door hinge.
3. Remove the (2) radio dials, the lock nuts behind the dials from the radio face panel, and the lower left hand and right hand panel screws. Remove the radio face panel. **NOTE: Retain all dash components and hardware.**

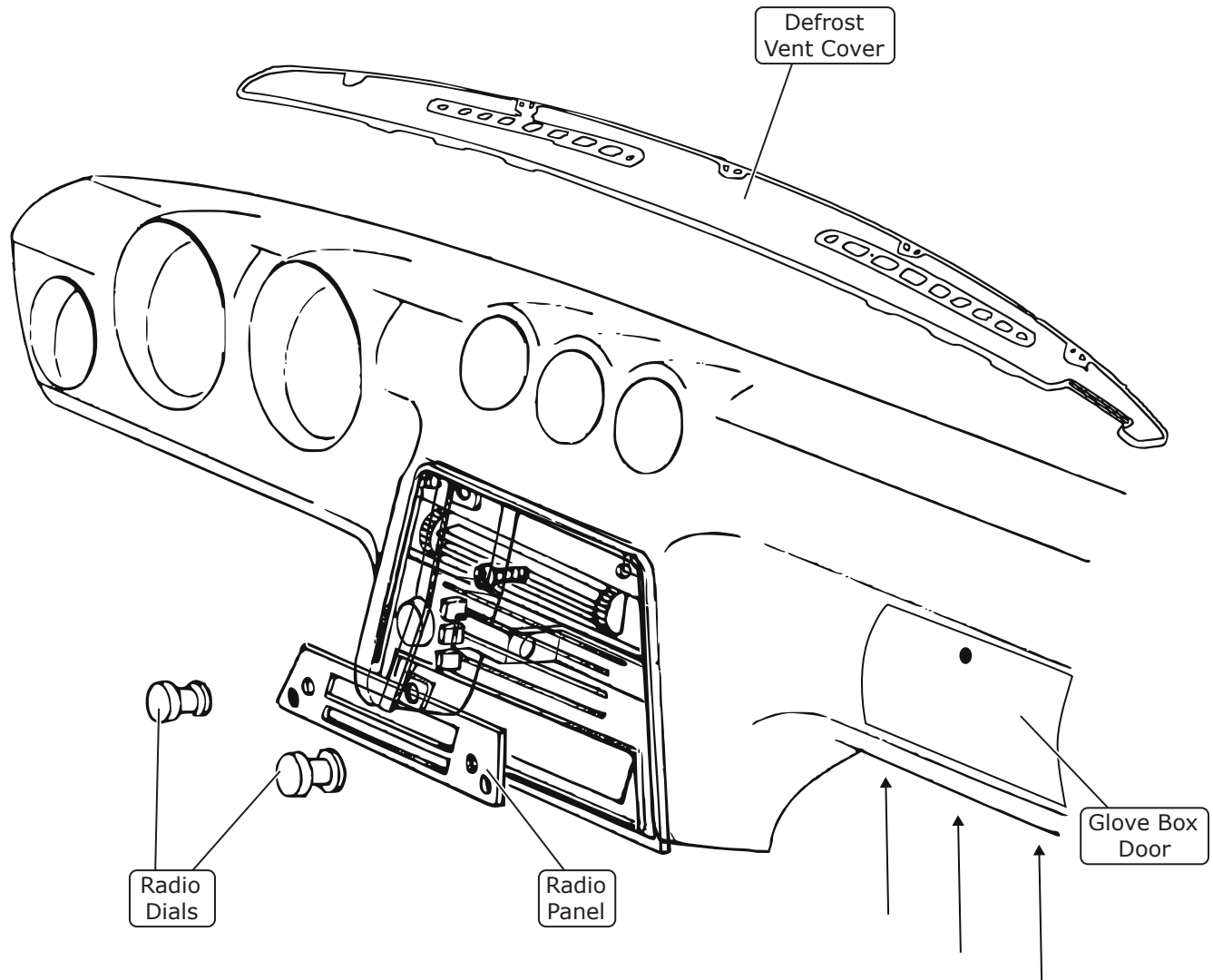

Figure 1



www.vintageair.com

Blower & Center Console Finisher Disassembly

1. Remove (3) screws securing the blower assembly to inside firewall (See Figure 1, below.)
2. Remove (1) screw from the mounting tab on top of the blower motor housing. Lower the blower assembly onto the floor board (See Photo 1 and Figure 1, below).
3. With proper clearance available now, disconnect the main power connector from the vehicle's harness (See Photo 1, below).
4. Disconnect the air vent door control cable from the blower assembly.
5. Disconnect all cables from the heater case unit.
6. Remove the (2) remaining screws on the top corners of the center dash bezel. Then carefully remove the entire bezel along with the OEM climate control panel assembly.
7. Remove the right hand L-bracket recessed behind and below the center area dash support (See Figure 2, below).

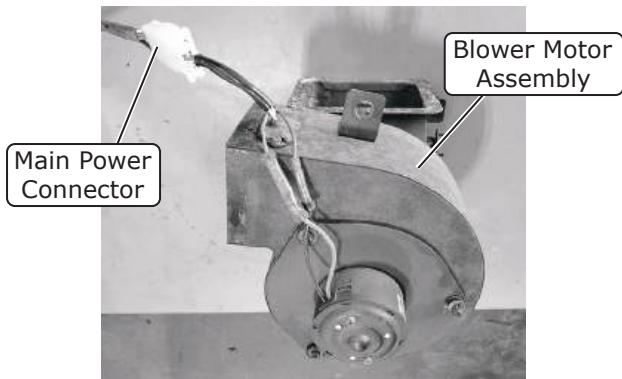

Photo 1

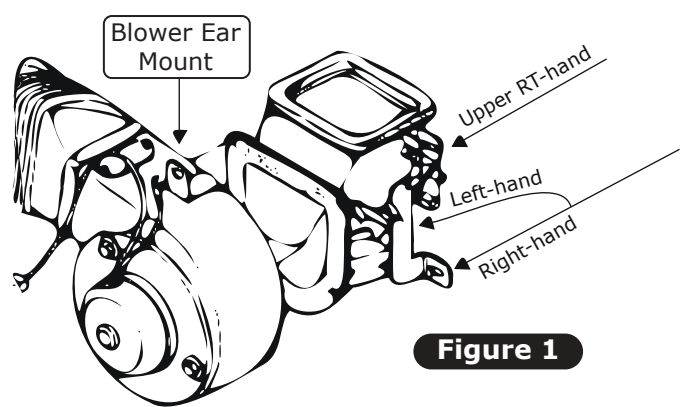

Figure 1

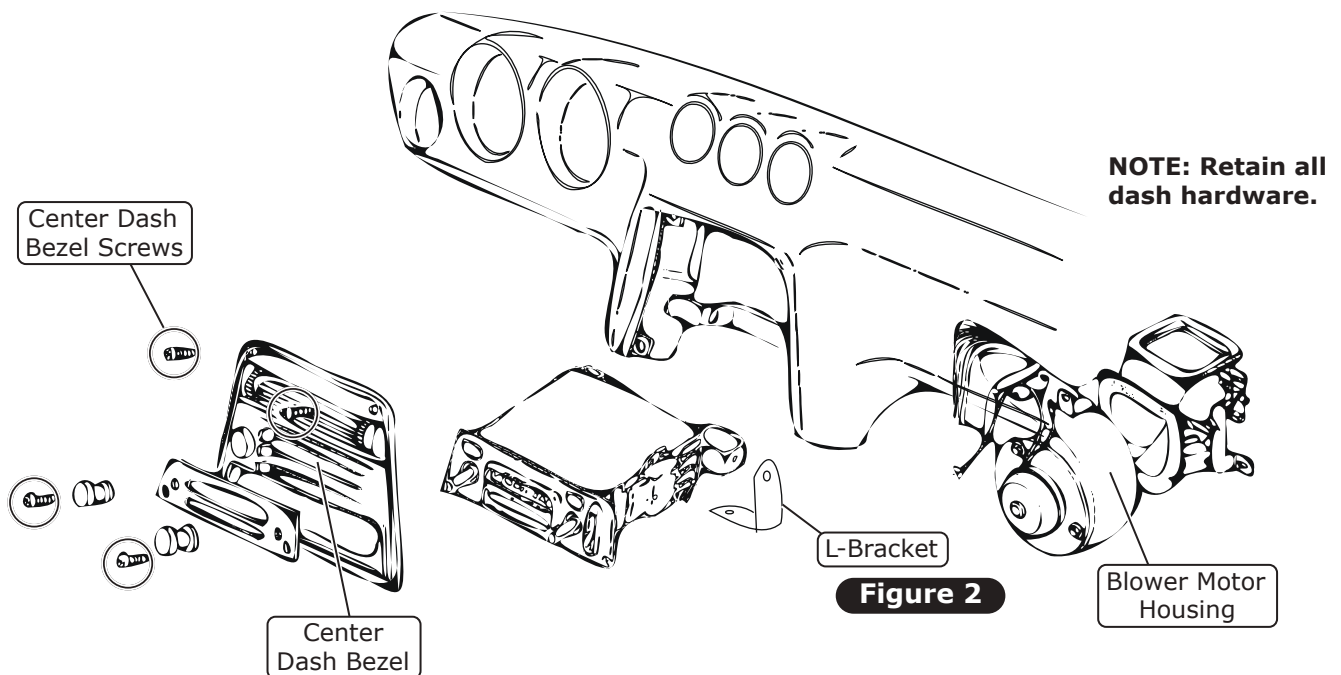

Figure 2



www.vintageair.com

Heater Core Disassembly & Removal

1. Remove all OEM duct hoses from behind the dash, along with the center distribution plenum, by removing the (6) screws securing it to the heater core.
2. The heater core case is anchored to the vehicle's body from (3) attachment points. Two upper mounting tabs and one "Z" bracket. Remove the hardware from items to release the heater core case from the vehicle's body (See Figure 1, below).
3. Carefully remove the heater core case from the passenger-side under dash area and lower onto the passenger floor board.

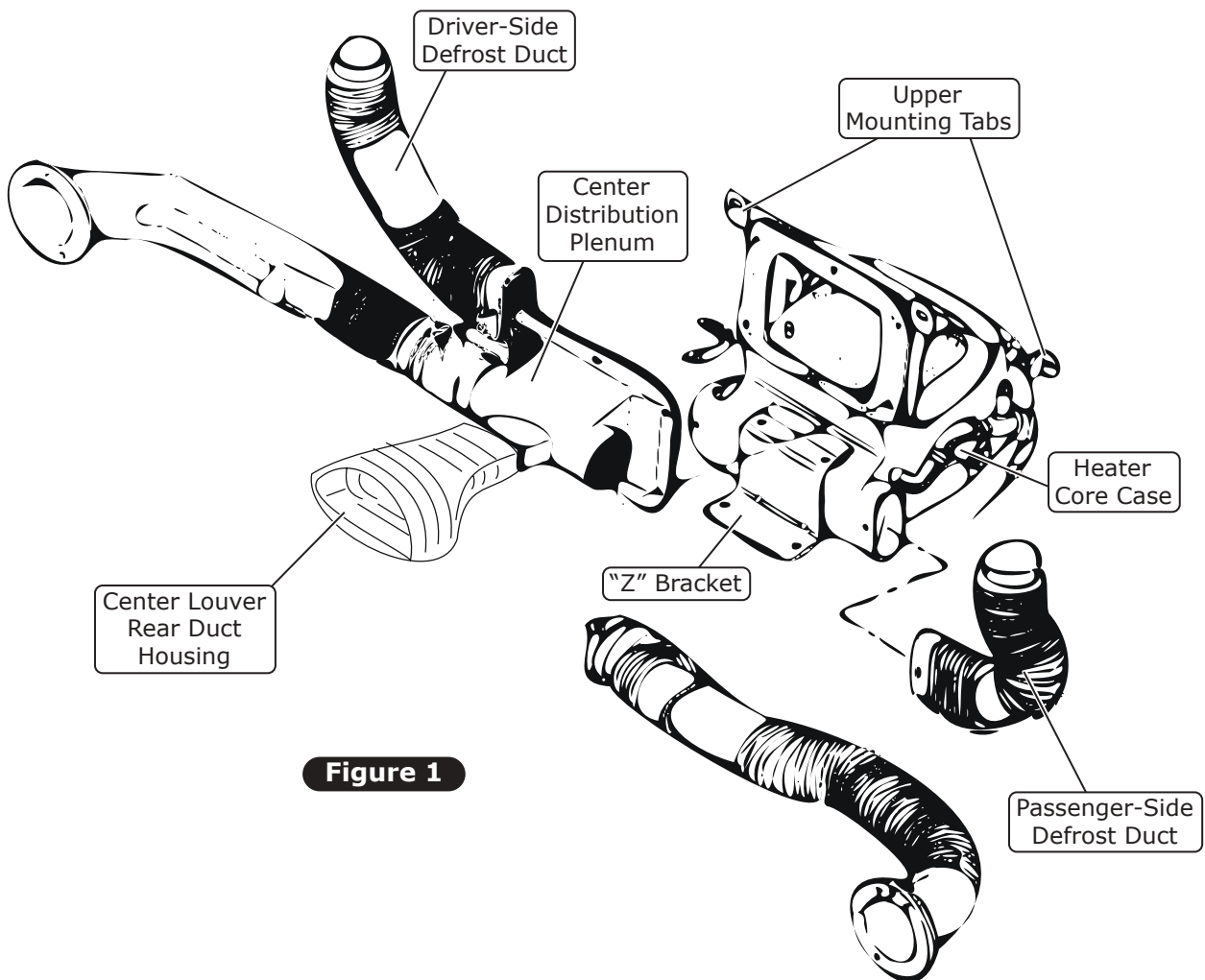

Figure 1



www.vintageair.com

Firewall Modification and Fresh Air Cap Installation

1. With the supplied template, place it against the passenger-side interior firewall where the template's V-groove feature falls and centers vertically into the firewall stamping. Slide the template's upper edge to the cowl's surface and insure flushed contact (See Figure 1, below).
2. Transfer all (4) 1/4" holes, remove the template and drill 1/4" diameter holes through the firewall.
3. With the supplied fresh air cap, apply silicone, around the fresh air caps edges (See Photo 1, below).
NOTE: Clean for a flat even surface before installing the fresh air cap. The template has an arm assist feature to keep the fresh air cap plate supported to allow the silicone to cure.
4. Install the fresh air cap over the opening then pin the template on as shown in Figure 2, below. Using the supplied 1/4-20 x 3/4" serrated flange bolts, let the fresh air cap cure (See Photo 1, below). **NOTE: If desired you may bolt the fresh air cap to the cowl for increased leak prevention.**

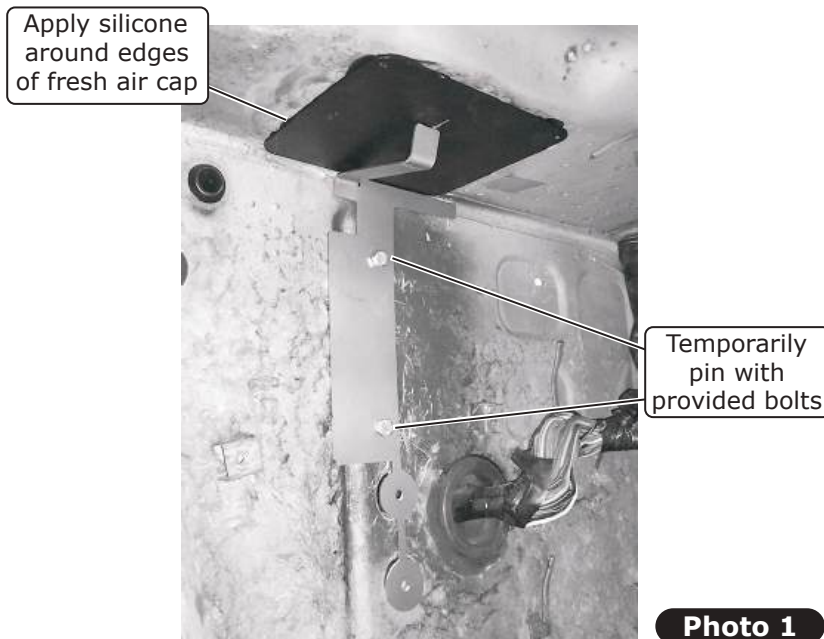
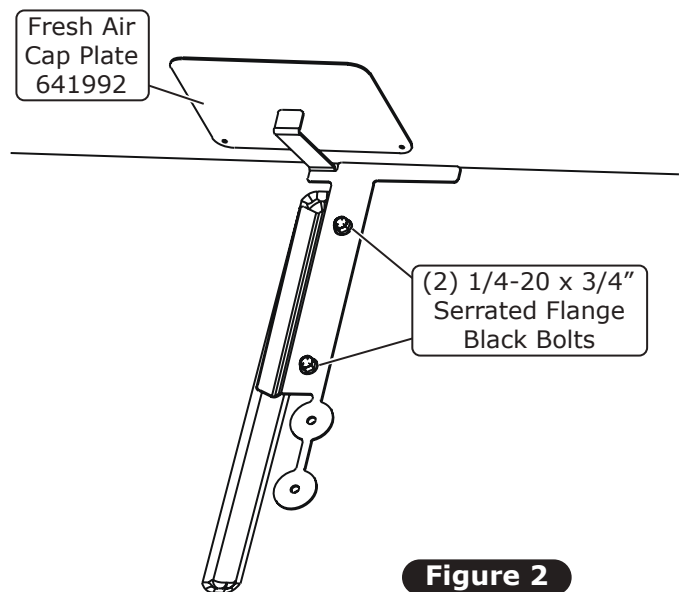
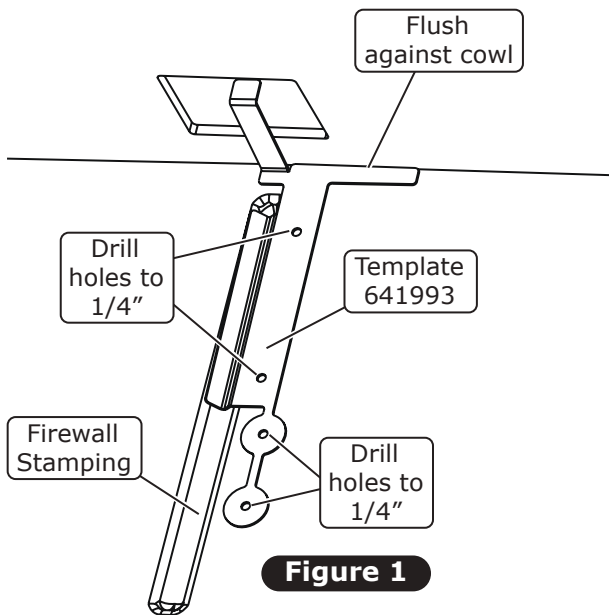



www.vintageair.com

Firewall Modification and Fresh Air Cap Installation (Cont.)

5. Remove the hardware and template from the firewall. Discard the template. Increase the diameters of the (2) lower 1/4" alignment holes to 1 1/4" (See Figure 3, below). **NOTE: Do not exceed hole size.**

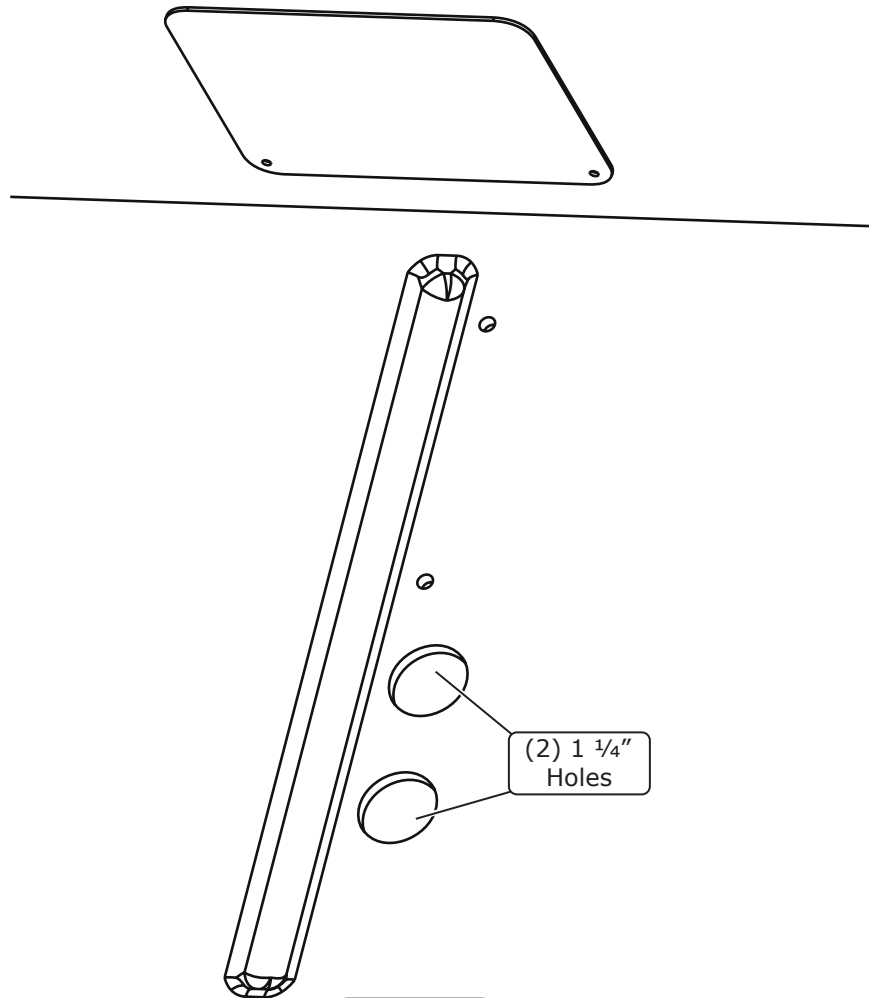



www.vintageair.com

Wiring Harness Installation

NOTE: Vehicle shown in photos may differ, for reference only.

1. From the passenger-side interior firewall compartment, choose from (2) recommended "X" hole locations (See Figure 1, below). Drill a 5/8" hole.
2. Insert the supplied 7/8" O.D. x 3/8" I.D. grommet into the 5/8" hole.
3. With the supplied wiring kit, begin installing the main harness in the passenger foot well, start by routing the heater control valve plug through the previously installed grommet (See Photo 1, below).
4. Route the red/white twisted wires through the grommet followed by the single blue wire (See Photo 2, below).
5. Attach the white ground wire with ring terminal to a suitable ground on the firewall or kick panel area (See Photo 3, below).
6. Mount the main harness relay where it will not interfere with the evaporator installation (See Photo 4, below).
7. Once the single blue wire is routed through the grommet, into the engine compartment, route the wire along the passenger frame rail until it meets to the A/C drier, located at the front side of the radiator core support. There you will crimp a supplied blue female spade connector to the wire and connect directly to one terminal post of the binary pressure safety switch. **NOTE: Condenser kit must be installed to complete this step.**
8. Carefully pull the excess wiring into the engine compartment. Leave some slack inside vehicle. Refer to Gen 5 Wiring Diagram and Wiring Instructions on Pages 36 and 37, for an in depth wiring schematic of the main harness.

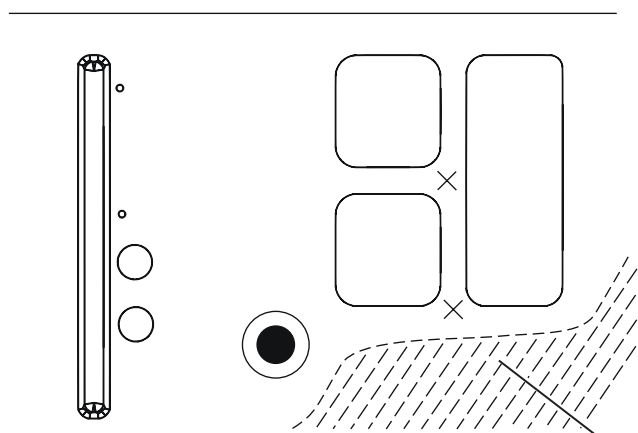

View from Firewall Interior

Figure 1

Unserviceable wheel well area

Route heater control valve plug through grommet

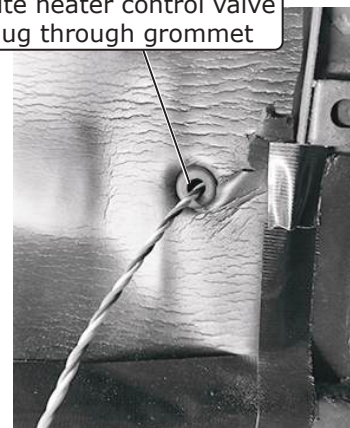

Photo 1

Route red/white twisted wires, and single blue wire through grommet



Photo 2

Attach white ground wire with ring terminal to suitable ground

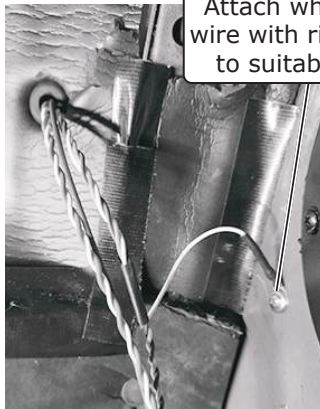

Photo 3

Mount main harness relay where it will not interfere with evaporator installation



Photo 4



www.vintageair.com

Heater Ports Grommet Install & Hose Preparation

1. With the supplied (2) large grommets, insert the grommets through the OEM heater ports (See Figure 1, below).
2. With (2) 5/8" inner diameter heater hoses (not supplied), pre-cut each hose to a length of 40".
3. From the engine bay, insert hoses into upper and lower heater grommets through the firewall (See Photo 1, below). **NOTE: A light spray of soapy water is recommended to ease hose insertion.**
4. From the inside passenger compartment, pull both heater hoses through until about 1 foot is left on the engine bay side.

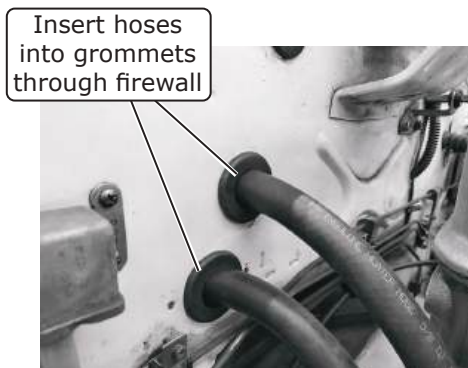
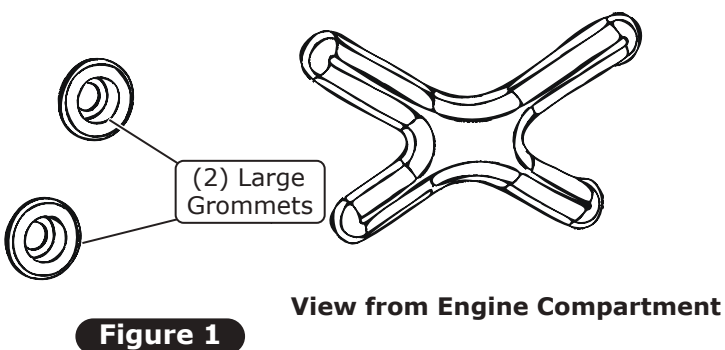

Defrost Duct & Dash Vent Adapters Installation

1. From the top of the dash, remove the (2) screws from the OEM defrost ducts (See Figure 1, below).

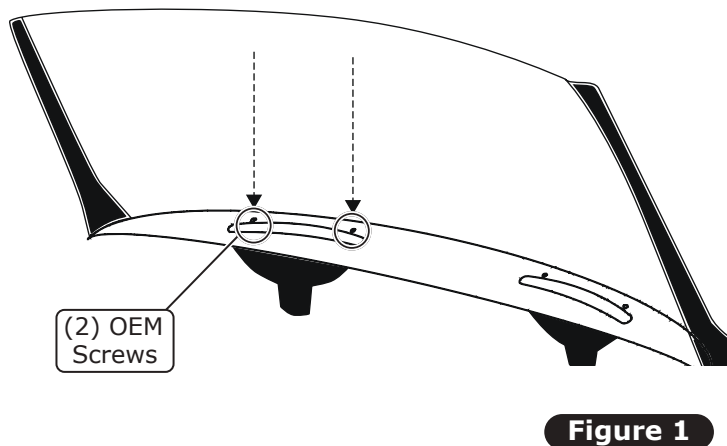



www.vintageair.com

Defrost Duct & Dash Vent Adapters Installation (Cont.)

2. With the (2) supplied defrost ducts, (2) defrost duct support brackets, (6) S-clips, and (4) 1/4" U-nuts, assemble items as shown in Figure 2, below.
3. Install defrost duct assemblies through the opening on top side of the dash (See Figure 3 and Photo 1, below).
4. With the (4) supplied 1/4-20 x 3/4" serrated flange bolts, secure defrost ducts to the cowl from under dash.

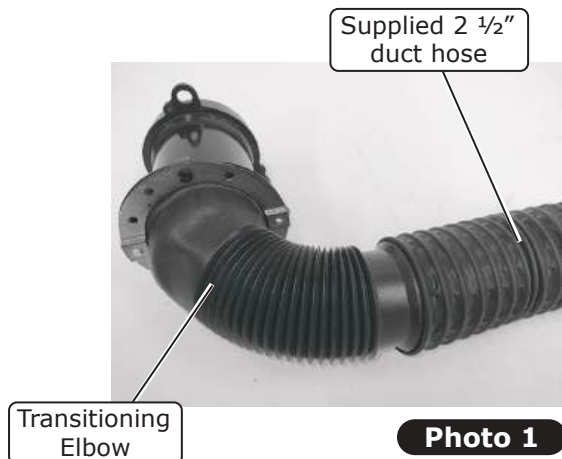
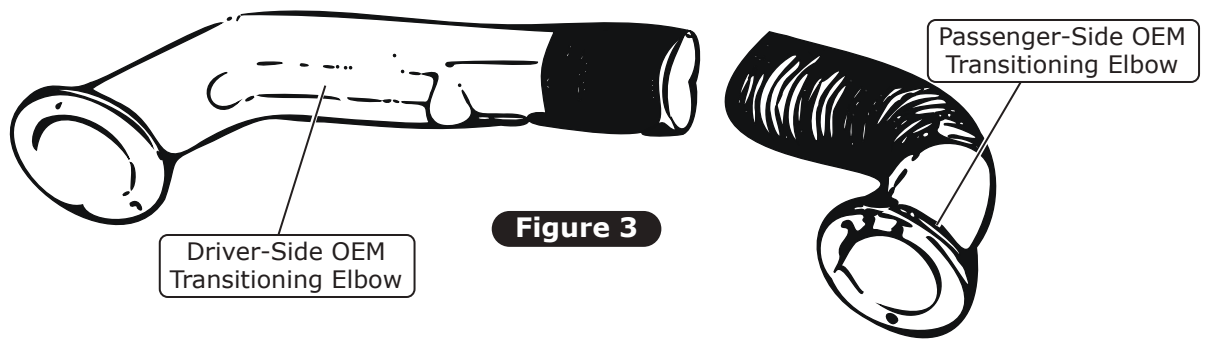
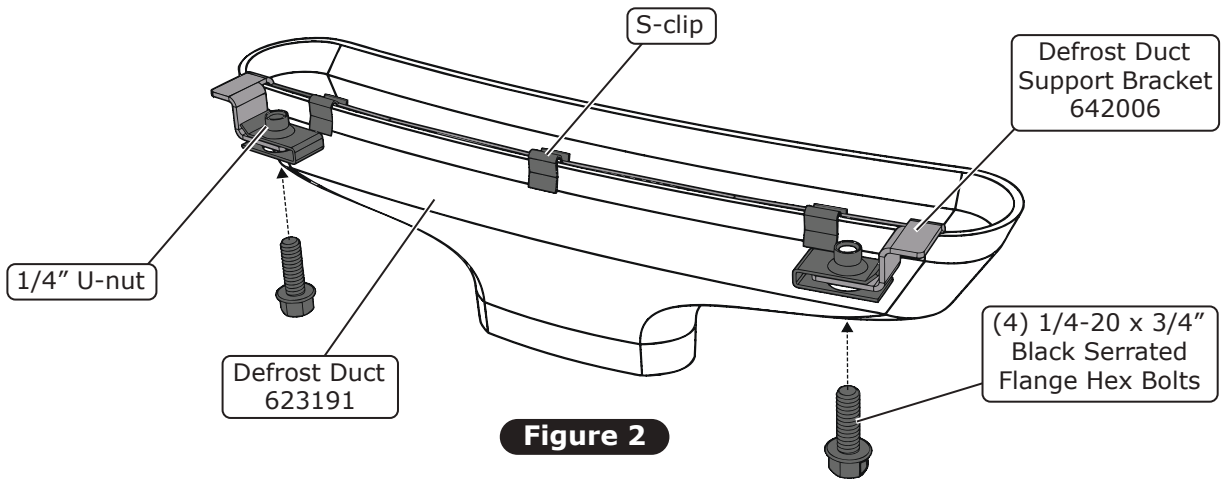



www.vintageair.com

Defrost Duct & Dash Vent Adapters Installation (Final)

5. Remove all driver and passenger-side louver OEM duct hoses. Disconnect hoses from transitioning elbows.
6. Remove the (3) screws securing each elbow to the housing flange (See Figure 4, below).
7. With the (2) supplied retaining ring plates, and (6) #8 x 1/2" wide head screws, assemble the items together for each OEM louver housing (See Figure 5 and 6, below). **NOTE: Do not install duct hoses yet. When instructed to, you will insert the 2 1/2" duct hose into the retaining ring plates by threading it in.**

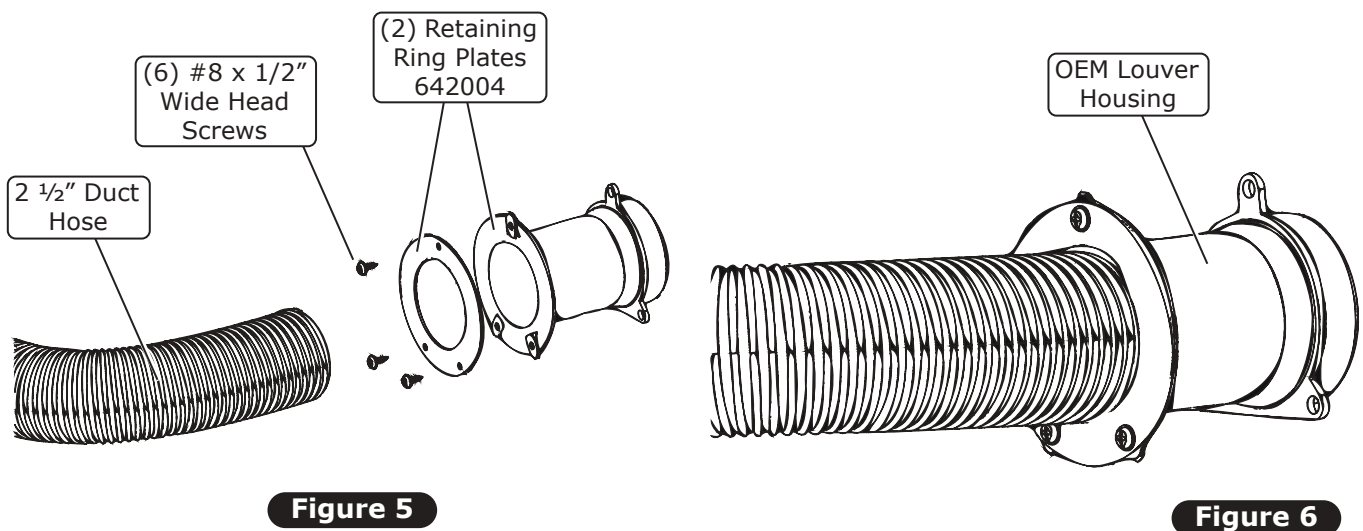
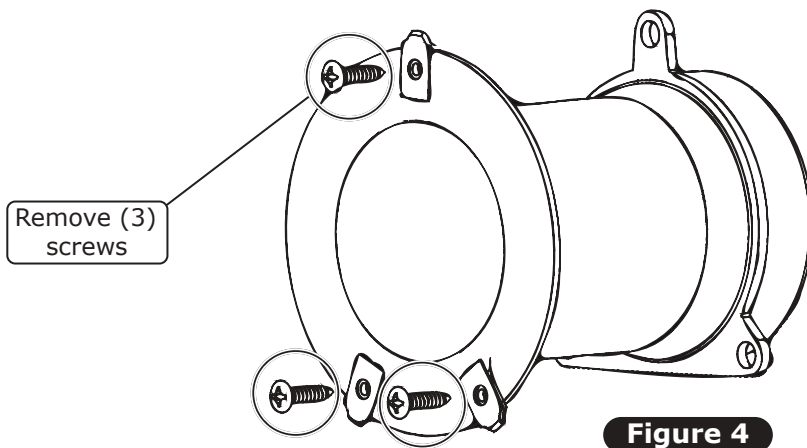



www.vintageair.com

Center Louver Housing Adapter Installation

1. With the supplied center louver adapter, place the adapter over the OEM rear center louver opening. Using the pre-drilled holes from the adapter, mark the holes onto the OEM rear center louver opening (See Figure 1 and 2, below).
2. Using a 1/8" drill bit, drill the previously marked holes.
3. With the (2) supplied #8 x 3/4" wide head screws, secure the adapter to the OEM center dash bezel.
4. Install the center dash bezel back onto the vehicle's dash. **NOTE: Control panel conversion kit must be completed before reinstalling the dash bezel. Refer to control panel conversion kit instructions to complete installation.**

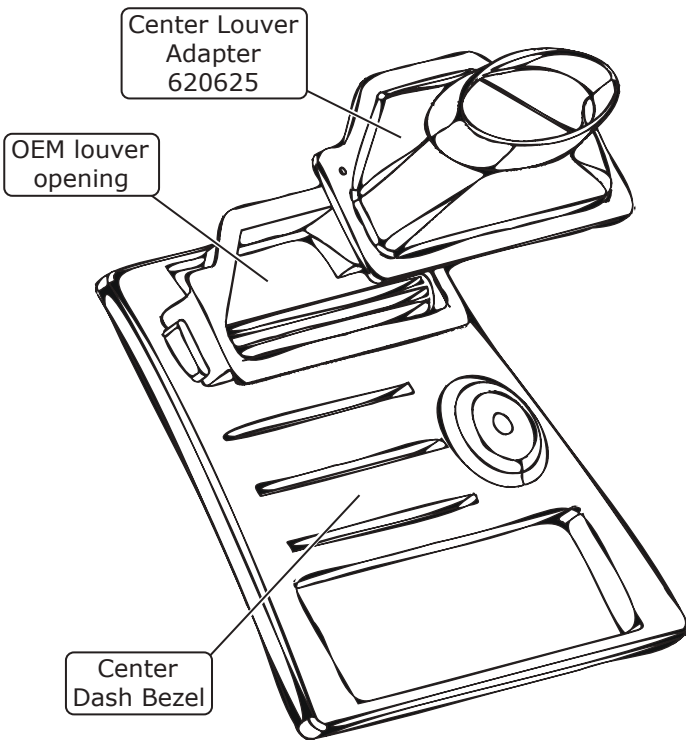

Figure 1

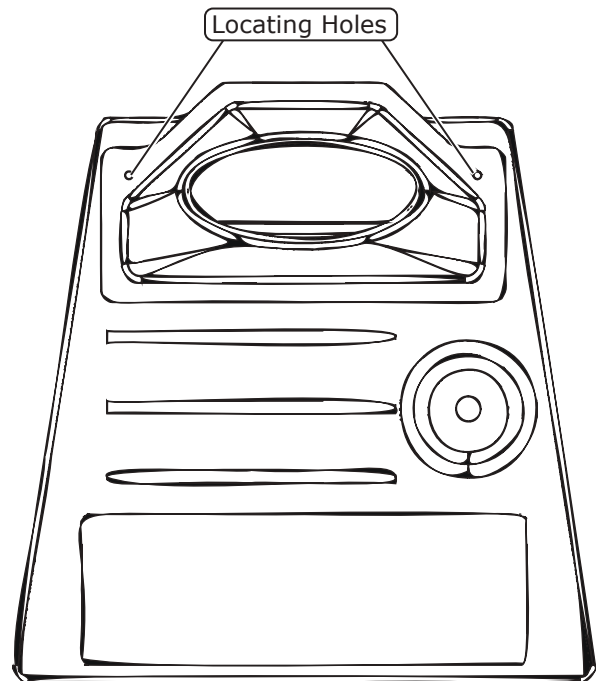
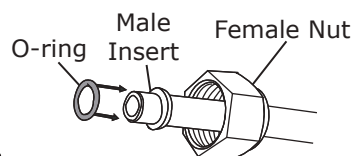
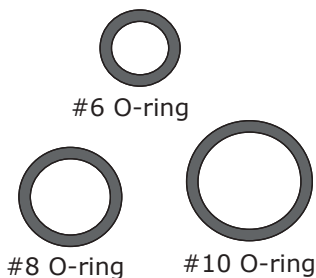

Figure 2

Lubricating O-rings & Fitting Torque Specs



For a proper seal of fittings: Install supplied O-rings as shown and lubricate with refrigerant oil.

Refrigerant Oil for O-rings
O-ring installs over male insert to swaged lip

Hold with this wrench

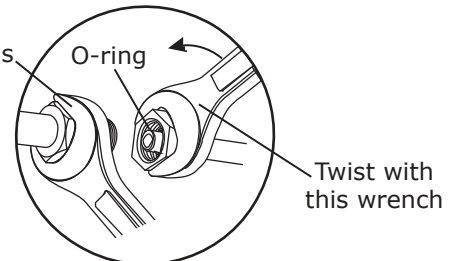

Twist with this wrench

NOTE: Standard torque specifications:
#6: 11 to 13 ft-lb.
#8: 15 to 20 ft-lb.
#10: 21 to 27 ft-lb.

The use of a backup wrench is recommended to reduce the chance of damaging the fittings/hardline.



www.vintageair.com

Properly Seated O-ring Land

When installing a hardline or A/C hose fitting onto the evaporator module, ensure the O-ring land is seated properly (See Photo 1, below). An improperly seated O-ring land (See Photo 2, below) can cause a leak. To properly install the fitting, slide the hardline or A/C hose nut back to expose the O-ring land and seat it onto the evaporator module fitting. Then, slide the hardline or A/C hose nut forward and thread it onto the evaporator module fitting, ensuring the O-ring land does not move or lift.

Properly Seated O-ring Land



Photo 1

Improperly Seated O-ring Land



Photo 2

NOTE: Photos shown are for reference only. Fittings may vary depending on kit received.

Evaporator Preparation & Installation

NOTE: Vintage Air recommends using heat-blocking insulation in the area around the evaporator module (firewall, kick panel, inner cowl, firewall covers). Due to tight clearance for the evaporator module between the firewall and dash, Vintage Air recommends an insulation thickness of no more than 1/4". To ensure a watertight seal between the passenger compartment and the vehicle exterior, for all bolts passing through the firewall, Vintage Air recommends coating the threads with silicone prior to installation.

1. Install the (4) supplied 1/2" plastic plugs and (1) well nut, onto the module (See Figures 1 and 2, below).

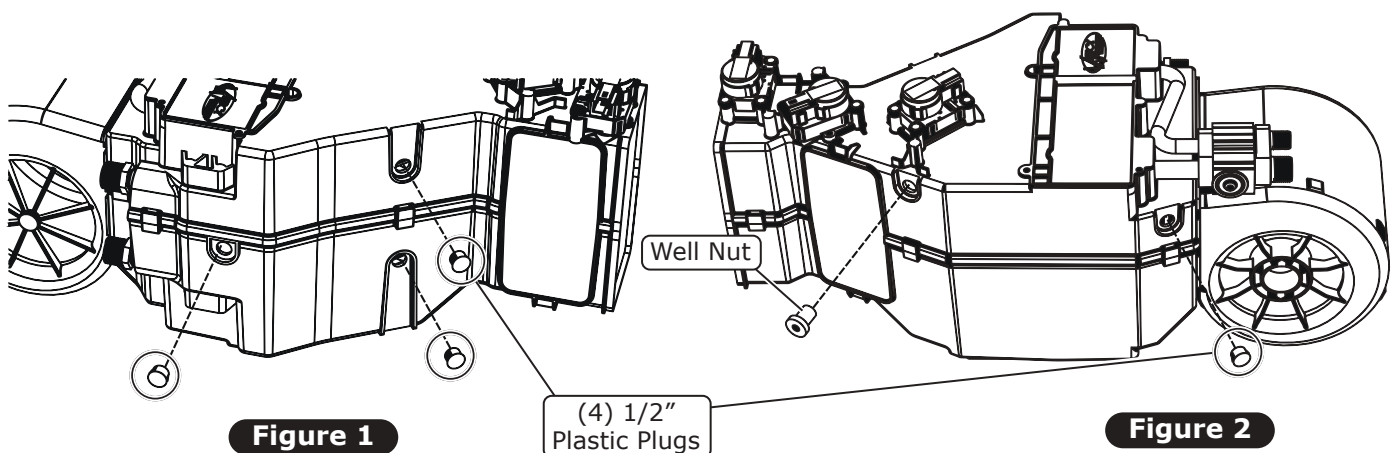

Figure 1

Figure 2



www.vintageair.com

Evaporator Preparation & Installation (Cont.)

2. Temporarily remove the (3) ECU mounting screws (See Figure 3, below). Remove the ECU from the module.
3. Install the supplied cowl bracket onto the module (See Figure 4, below). Secure the bracket with a supplied 1/4-20 x 1" serrated flange bolt into the well nut, then reinstall the ECU. **NOTE: Do not tighten ECU mounting screws yet.**
4. Install the (2) supplied heater hardlines onto the evaporator module (See Figure 5, below). **NOTE: Keep both hardlines parallel to one another and perpendicular to module's case.**
5. With the supplied firewall bracket and (4) #10 x 5/8" screws install the bracket onto the evaporator case and secure with screws (See Figure 6, below).

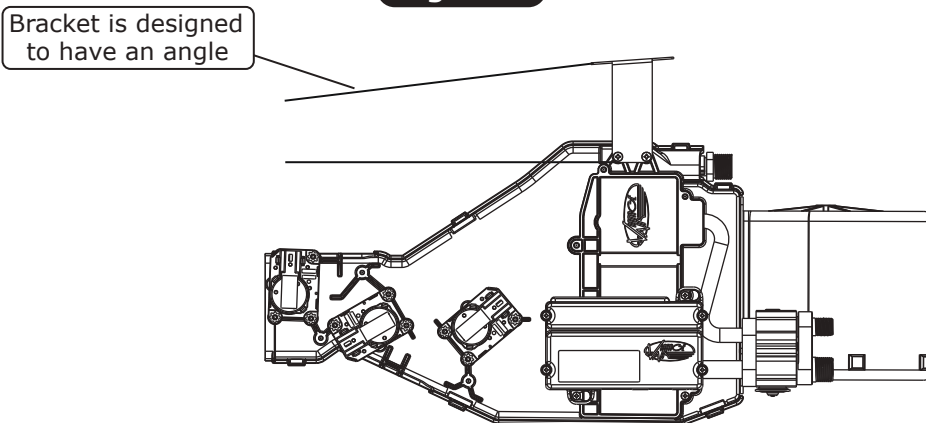
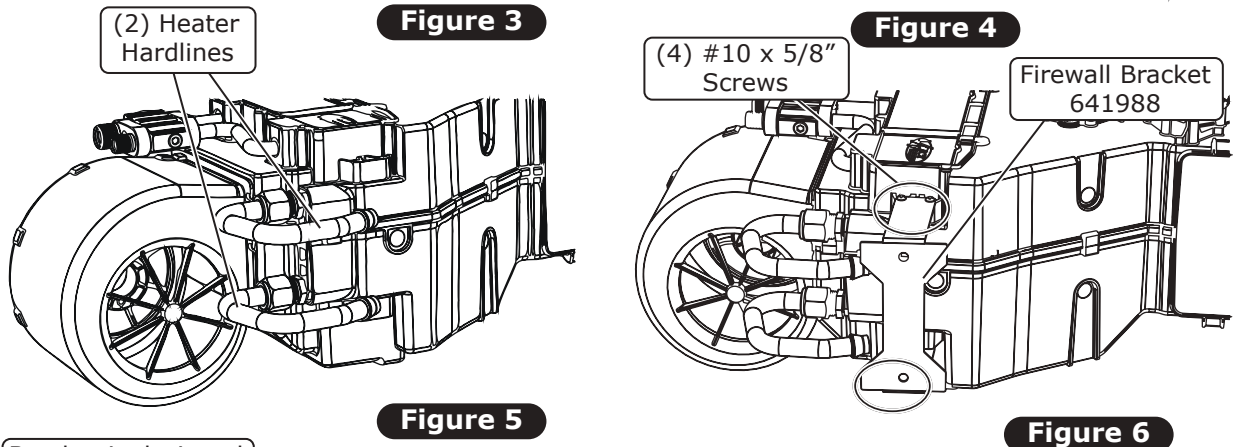
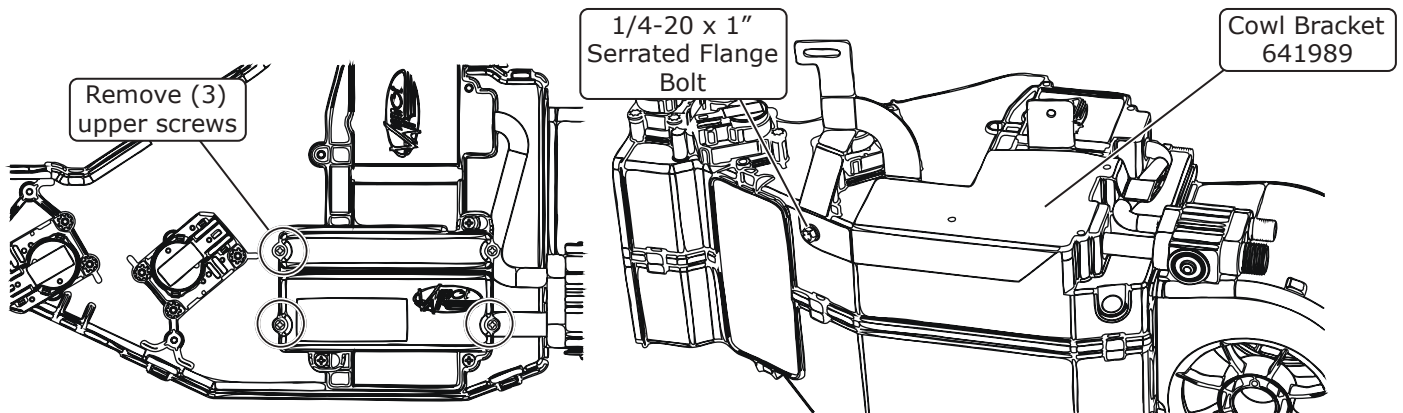



www.vintageair.com

Evaporator Preparation & Installation (Cont.)

6. Install the dash, defrost and floor plenums onto the module case and secure with spring clips (See Figures 8 - 10, below).

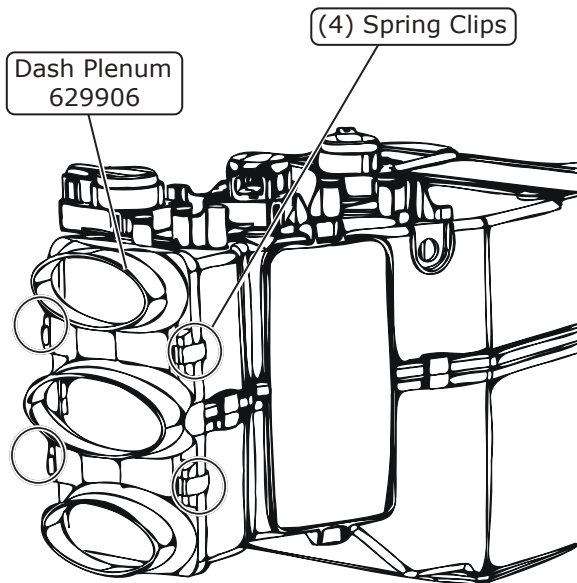

Figure 8

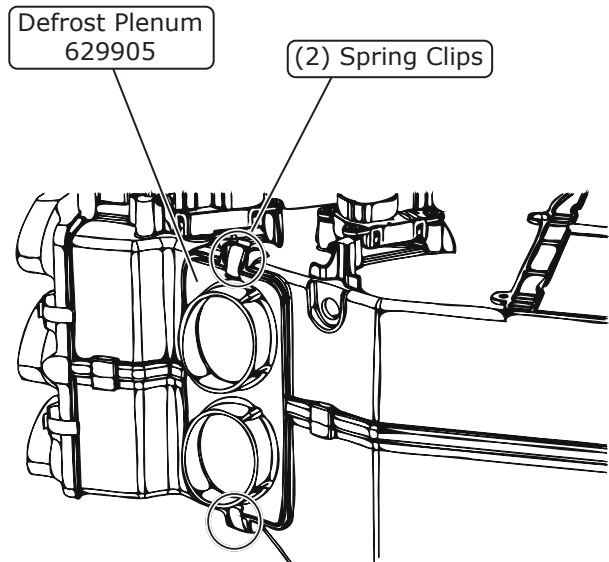

Figure 9

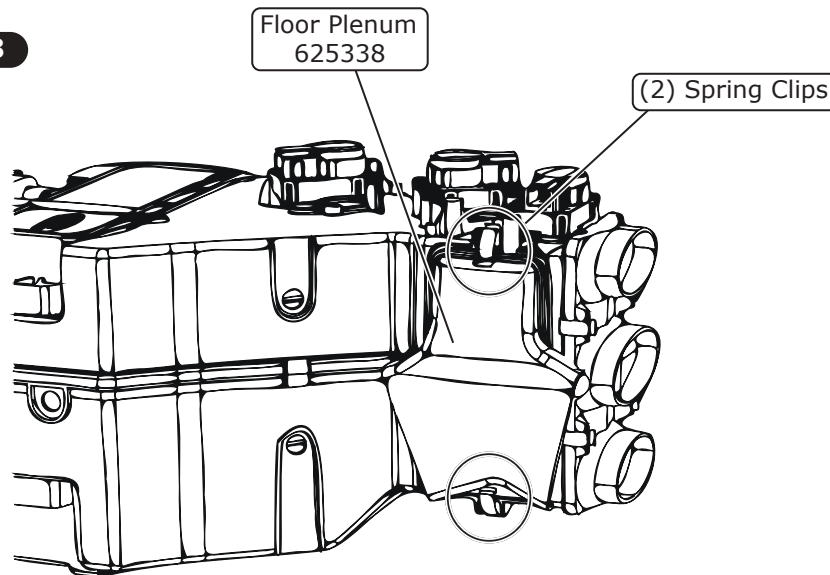

Figure 10



www.vintageair.com

Evaporator Preparation & Installation (Cont.)

7. With the (2) 1/4-20 full-threaded studs, install each stud to the firewall bracket weld nuts (See Figure 11, below). **NOTE: Studs have an Allen key pocket end for 1/8" key'd wrench. Allen key pocket is to be facing out and away from the bracket to be accessible for later removal (See Figure 11, below).**
8. Place the evaporator module onto the passenger-side floor board with the heater hardlines facing up, locate the (2) heavy gauge orange and white wires coming off. Insert the (2) wires through the previously installed wiring grommet on the firewall (See Photo 1, below).
9. Install the (2) 5/8" heater hoses coming through the firewall, connect the lower hose onto the lower heater hardline and the upper hose onto the upper heater hardline, secure with the (2) supplied hose clamps.
10. Reposition the evaporator case to resemble Photo 2, below. Carefully lift the evaporator case up behind the dash while feeding the excess heater hose through the firewall.

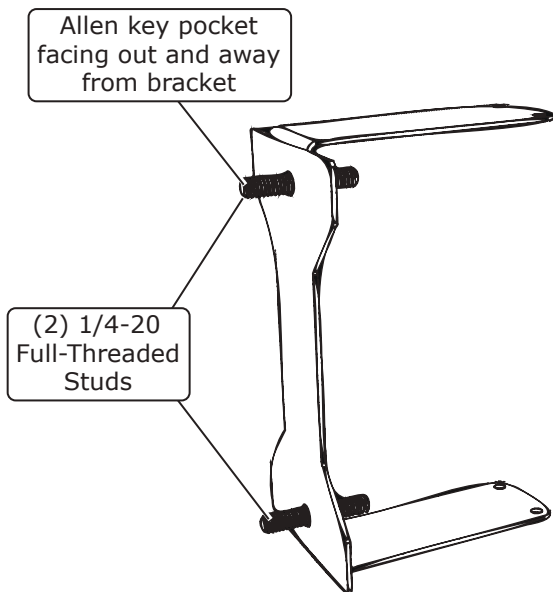

Figure 11

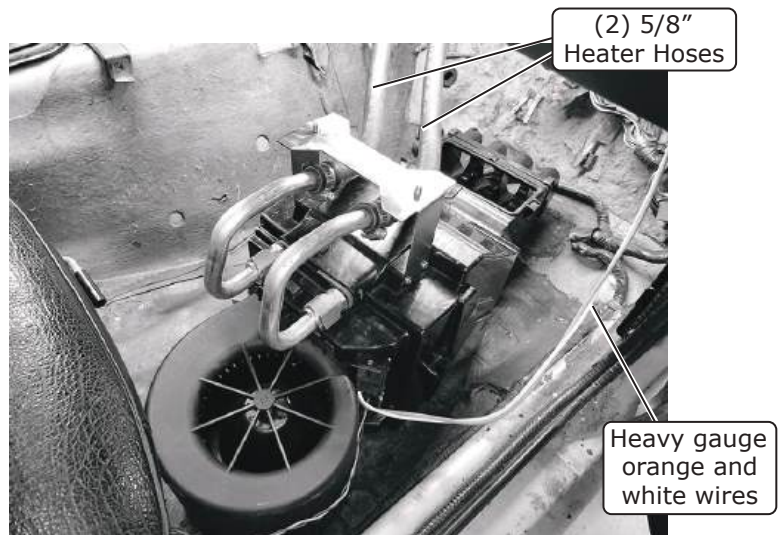

Photo 1

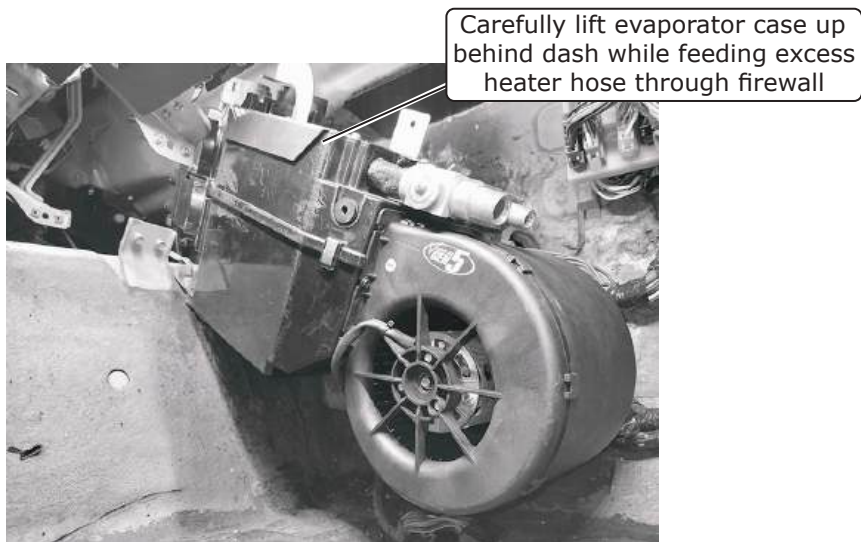

Photo 2



www.vintageair.com

Evaporator Preparation & Installation (Final)

11. Once the firewall bracket is aligned to the previously drilled (2) 1/4" holes and the full-threaded studs are protruding through the firewall into the engine compartment. Verify the lower right cowl bracket support is aligned to the OEM blower mount (See Figure 12, below). With the supplied T30 M6 x 1" truss head bolt, secure bracket to the OEM blower mount.
12. Align upper left cowl bracket support to the vehicle's OEM heater case mount (See Figure 12, below). With the supplied T30 M6 x 1" truss head bolt, secure the bracket to the mount.
13. From the engine compartment firewall side, remove the full-threaded studs one at a time, and install the (2) supplied 1/4-20 x 3/4" black serrated flange bolts in their place (See Figure 13, below).
14. Tighten the ECU mounting screws.

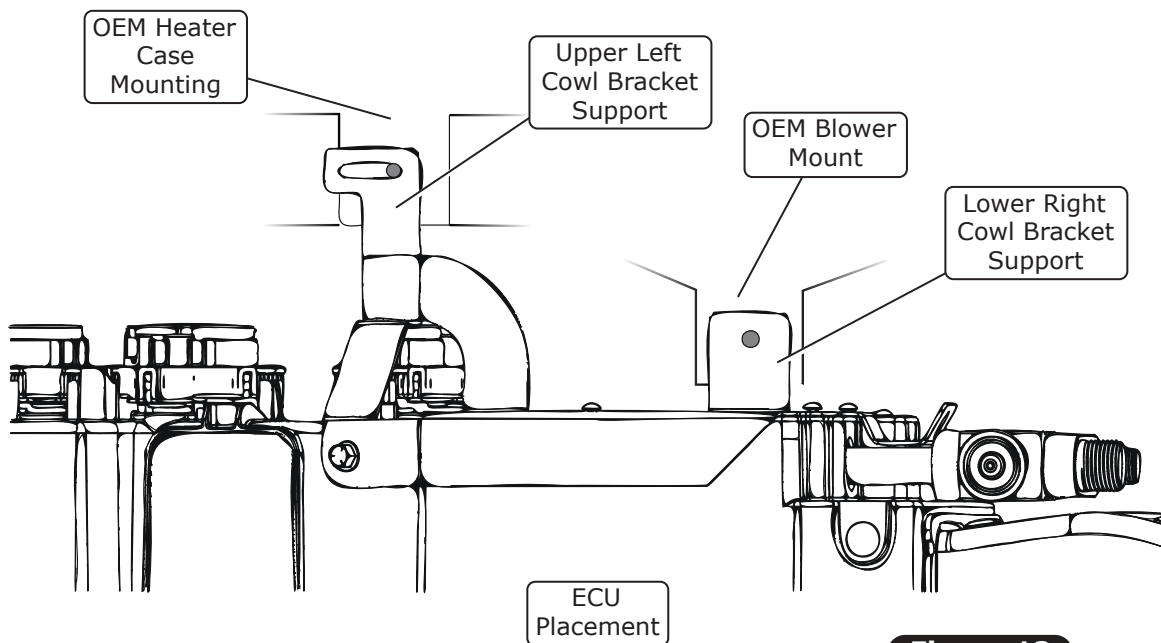

Figure 12

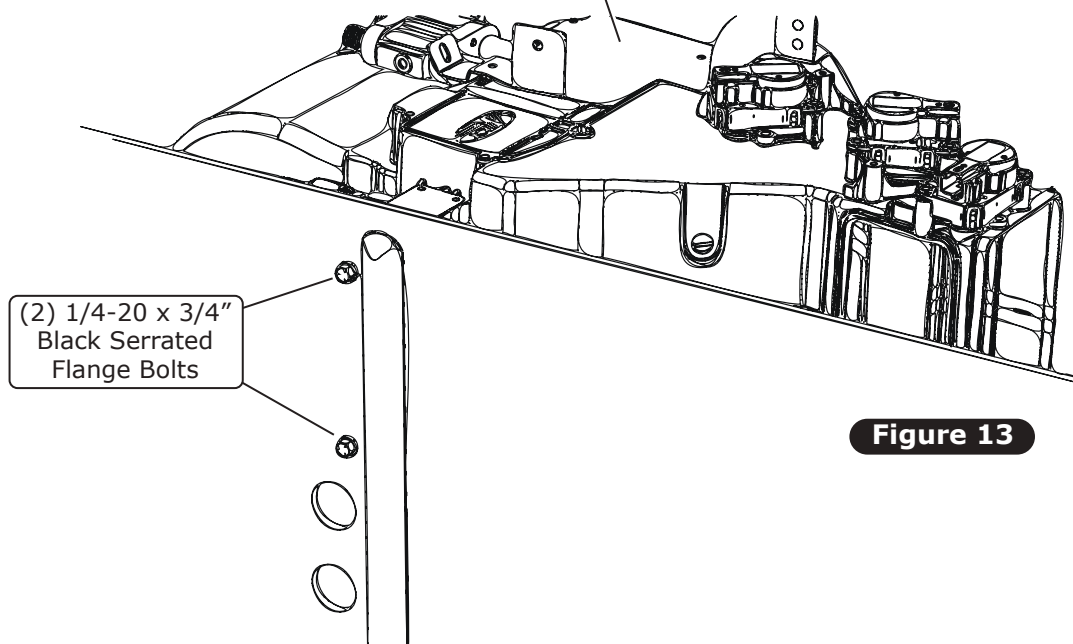

Figure 13



www.vintageair.com

Drain Hose and Grommet Installation

1. Locate the evaporator drain on the bottom of the evaporator case.
2. Mark the transmission tunnel about 3.5" lower than the drain about 1" back from the firewall.
3. Before drilling, check the engine bay side for any potential interference. Then drill a 1" hole on the previously marked spot.
4. With the supplied 1 1/4" O.D. x 11/16" I.D. grommet, insert the grommet into the 1" hole.
5. With the supplied 1/2" drain hose, cut the hose to 9".
6. With the supplied 1/2" drain elbow, insert the elbow into the 9" drain hose cut section. **NOTE: Drain elbow should be facing down in engine bay.**
7. Insert the drain elbow end into the grommet.
8. Connect hose end to evaporator case drain port.

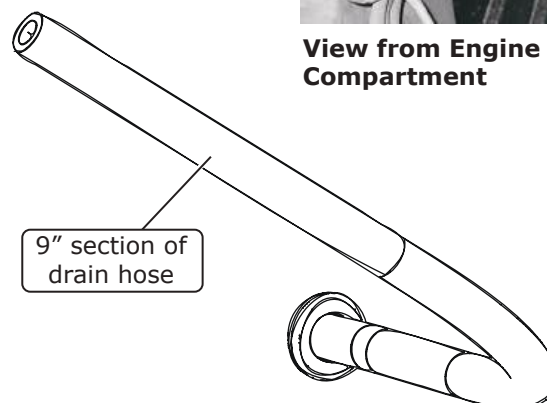
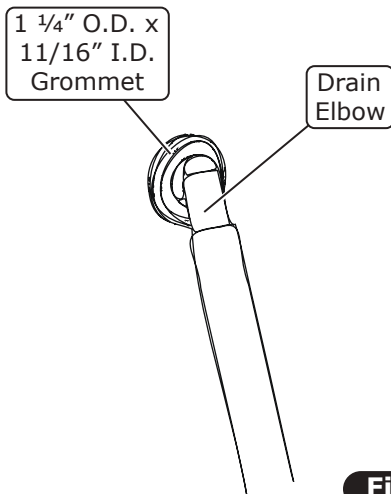
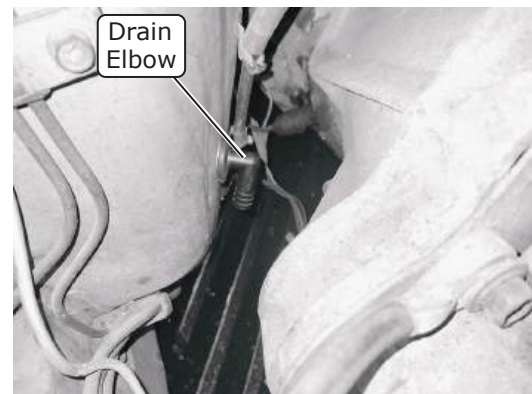
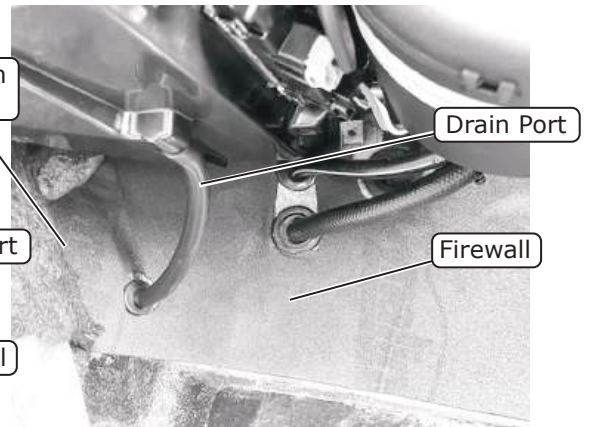
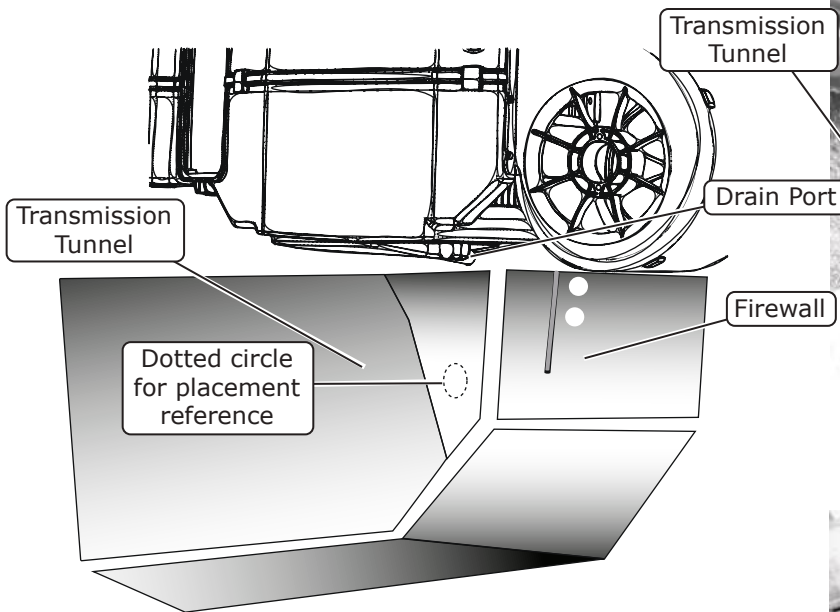



www.vintageair.com

Heater Control Valve Installation

NOTE: Vintage Air systems use 5/8" heater connections. On engines equipped with 3/4" hose nipples, these will need to be removed and replaced with 5/8" nipples (not supplied). For water pumps with a cast-in 3/4" heater outlet, a 3/4" x 5/8" reducer fitting (not supplied) or molded hose will need to be installed in the heater hose.

1. Pull all excess hose into engine bay, ensure hoses are not kinked or twisted under the dash.
2. Trim the upper hose to length and connect it to the water port on the rear of the block.
3. Connect the lower hose to the water pump fitting toward the front of the engine and install the heater control valve in line (See Photos 1 and 2, below). **NOTE: The heater control valve is directional refer to Figure 1, below, for correct installation.**

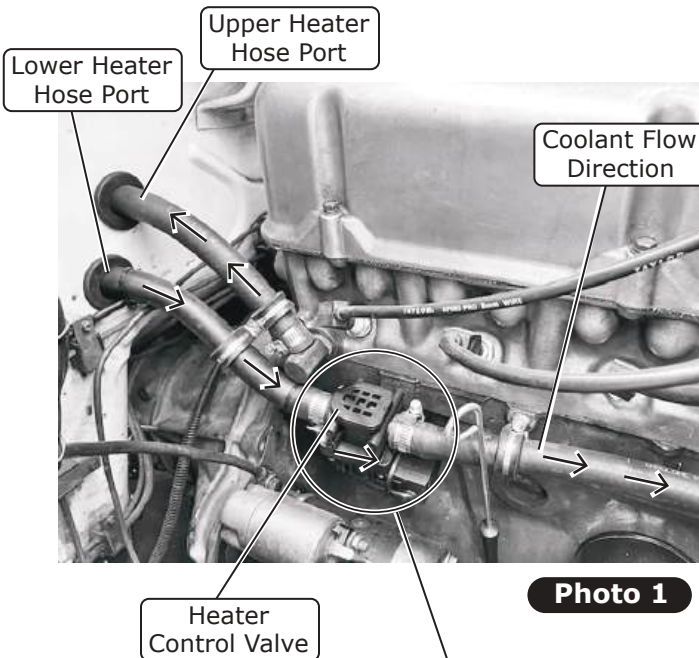

Photo 1

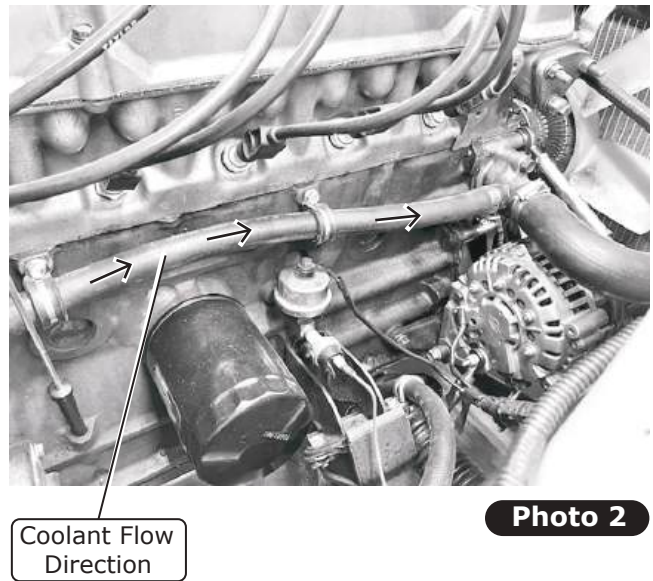

Photo 2

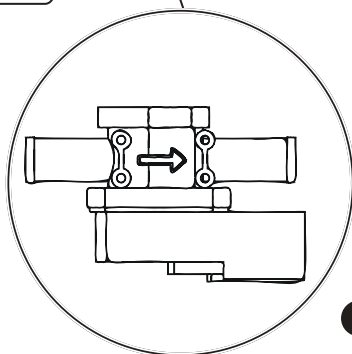

Figure 1

NOTE: Flow Direction Follows Molded Arrow on Valve



www.vintageair.com

A/C Hose Installation

1. Locate the #8 A/C hose, and with properly lubricated #8 O-rings (See Lubricating O-rings & Fitting Torque Specs & Fitting Torque Specs, Page 16), loosely install the hose end with the 90° fitting onto the corresponding port on the rear of the A/C compressor, then connect the hose end with the straight fitting to the previously installed #8 condenser hardline as shown in Photo 1, below. Tighten fittings.
2. Locate the #10 A/C hose and route the hose end with the 135° fitting from the driver side of the engine bay to the passenger side bypassing the hose under the engine directly behind the compressor.
3. With a properly lubricated #10 O-ring (See Lubricating O-rings & Fitting Torque Specs, Page 16), connect the hose end with the 90° fitting to the corresponding port on the rear of the A/C compressor (See Photo 2, below). Leave loose.
4. Route the #10 A/C hose in front of the passenger-side motor mount to frame the rail toward the firewall. **NOTE: Secure the hose to the motor mount and ensure it is free and clear of any moving parts on the steering rack or suspension (See Photo 3, below). Depending on your vehicle's configuration, the #6 A/C hose can also be secured using an Adel clamp (not included) on the motor mount (See Photo 4, below).**
5. Locate the #6 A/C hose, and with a properly lubricated #6 O-ring (See Lubricating O-rings & Fitting Torque Specs, Page 16), connect the hose end with service port to the open end of the drier and route the hose through the core support. Adjust the fitting so there is no contact with the core support to prevent chafing and tighten (See Photos 5 and 6, below).

Connect hose end with 90° fitting to port on rear of A/C compressor



Connect hose end with straight fitting to #8 condenser hardline

Photo 1



Photo 2

Ensure hose is free and clear of any moving parts on steering rack or suspension



Photo 3

#6 A/C hose can also be secured using an Adel clamp (not supplied)



Photo 4

Adjust fitting so there is no contact with core support



Photo 5



Photo 6

A/C Hose Installation (Cont.)

6. Route the #6 and #10 A/C hoses together along the frame rail toward the firewall, secure with the provided tie wraps (See Photos 7 and 8, below).
7. Install the provided 1 1/4" with 3/8" hole grommet and large grommet onto the #6 and #10 A/C hoses as shown in Photo 9, below.
8. The #10 A/C hose will need to be situated as shown in Photo 10, below, to fit through the hole on the firewall.
9. Route the hoses through the previously drilled holes on the firewall then secure the grommets (See Photos 11 and 12, below).

Route #6 and #10 A/C hoses together along frame rail



Photo 7

Secure with tie wraps



Secure with tie wraps

Photo 8

Large Grommet

1 1/4" with 3/8" Hole Grommet

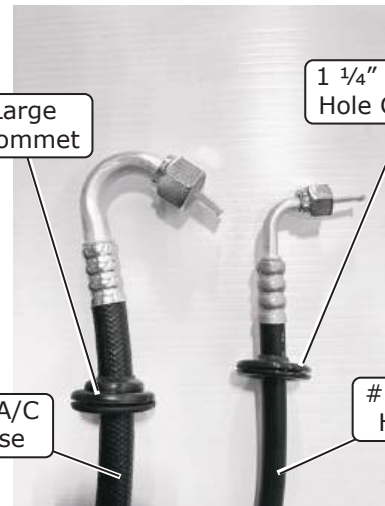

#8 A/C Hose

#6 A/C Hose

Photo 9

#10 A/C hose will need to be situated as shown



Photo 10



Route hoses through previously drilled holes on firewall

Photo 11

Secure grommets



Photo 12



www.vintageair.com

A/C Hose Installation (Final)

10. Once the hoses are installed through the firewall immediately recap the #10 A/C hose to keep it free of debris and moisture (See Photo 13, below).
11. Route the #6 A/C hose up behind the evaporator module and with a properly lubricated #6 O-ring (See Lubricating O-rings & Fitting Torque Specs, Page 16), connect it to the corresponding port on top of the evaporator module (See Photo 14, below).
12. Route the #10 A/C hose up behind the evaporator module and with a properly lubricated #10 O-ring (See Lubricating O-rings & Fitting Torque Specs, Page 16), connect it to the corresponding port on top of the evaporator module (See Photo 15, below). Be sure the #10 fitting is not pressed against the #6 fitting at the evaporator module when tightened.
13. Apply provided press tape to #10 line and fitting (See Photo 16, below).
14. With the (2) supplied 11" tie wraps, restrain both #10 and #6 hoses together nearest to the rear blower motor area (See Photo 17, below). **NOTE: Evenly space tie wraps about 5" apart. Pull enough hose slack into the passenger compartment to sweep low and immediately up to avoid contact with rear heater hardlines.**



Once hoses are installed, recap #10 A/C hose immediately to keep free of debris and moisture

Photo 13

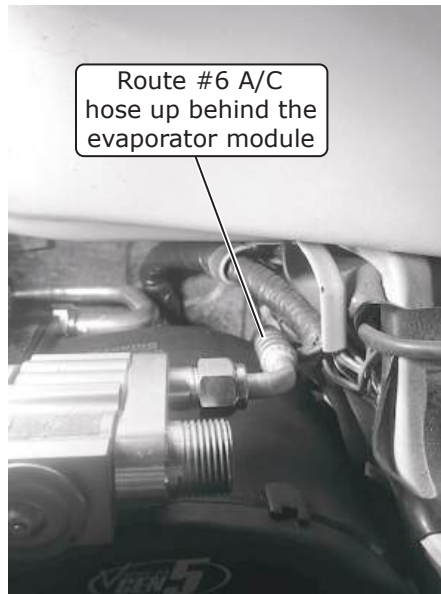

Route #6 A/C hose up behind the evaporator module

Photo 14



Route #10 A/C hose up behind the evaporator module

Photo 15

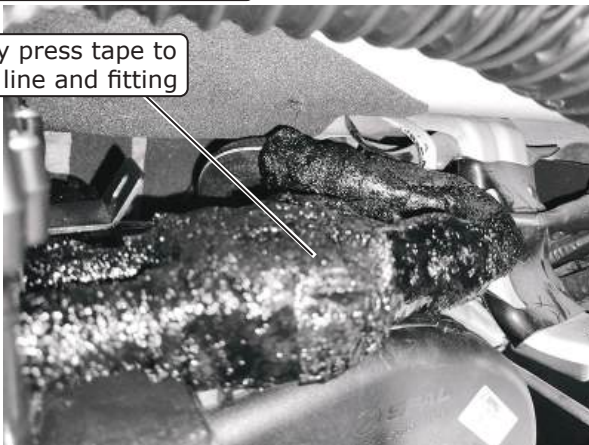

Apply press tape to #10 line and fitting

Photo 16



Restrain both #10 and #6 hoses together with supplied 11" tie wraps

Photo 17



www.vintageair.com

A/C and Heater Hose Routing

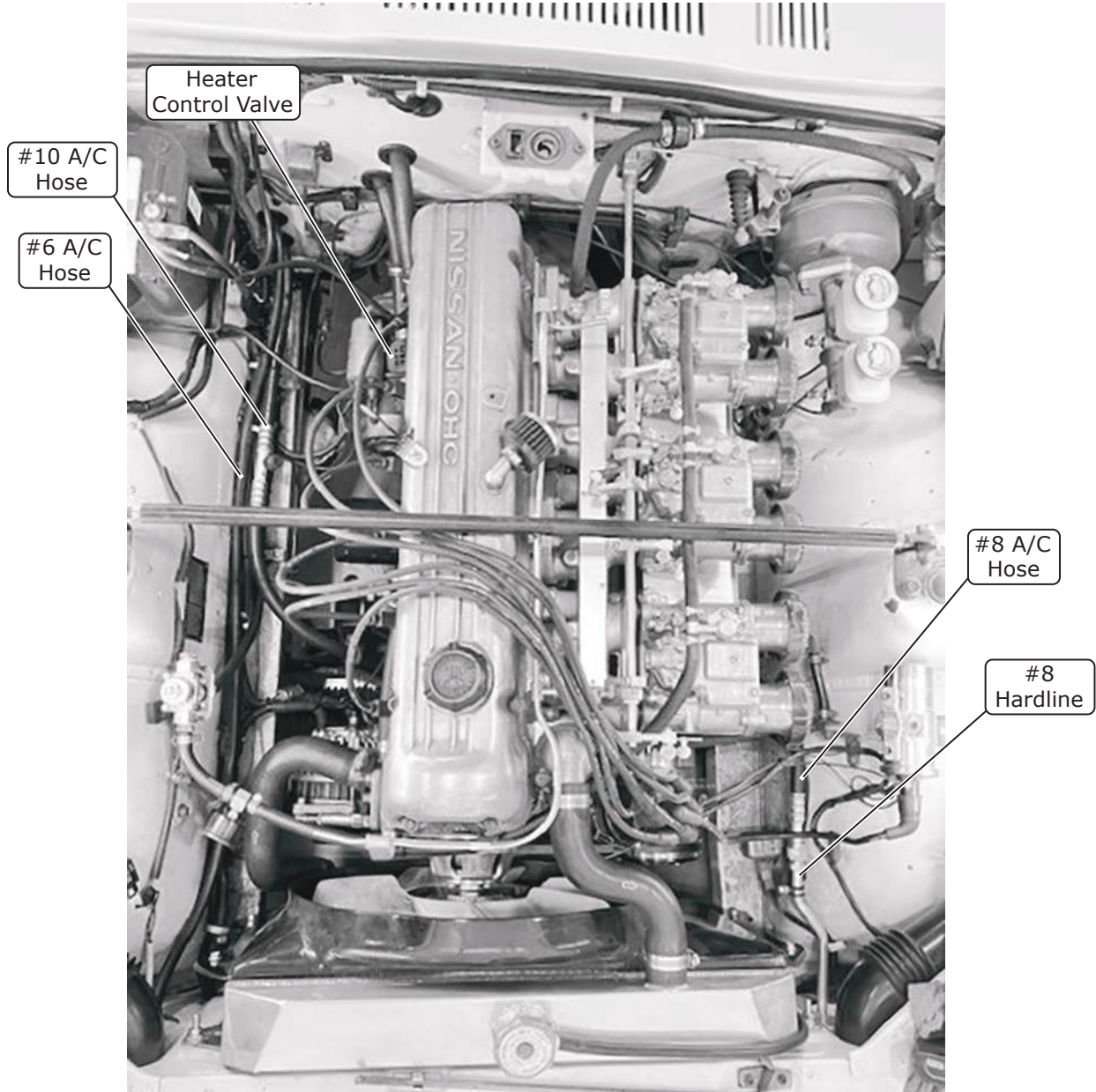

Disclaimer: The illustration above is for reference only. Hose routing and fittings may differ depending on install and/or engine configuration.



www.vintageair.com

Wiring

1. Select a suitable ground location for the white ground wire eyelet from the heater control valve harness (See Figure 1, below) and secure it using a #12 x 1/2" self-tapping screw.
2. Route the violet power wire to a switched 12v power source.
3. Connect the tan wire to the factory dash lights to enable control panel backlighting (if applicable).
4. Connect the main harness to the ECU (See Figure 2, below).
5. Select a suitable mounting location for the main relay.
6. Connect the violet/yellow/white twisted branch with 3-position connector into the heater control valve connector (See Figure 1, below). Ensure that the mating latch is fully seated.
7. From the underside of the evaporator module, locate the twisted bundle of green and orange strand wires joined together with a connector (See Photo 1, below). Locate the color matching twisted bundle wires from the main harness nearest to the ECU connector and connect both connectors together (See Photo 2, below).

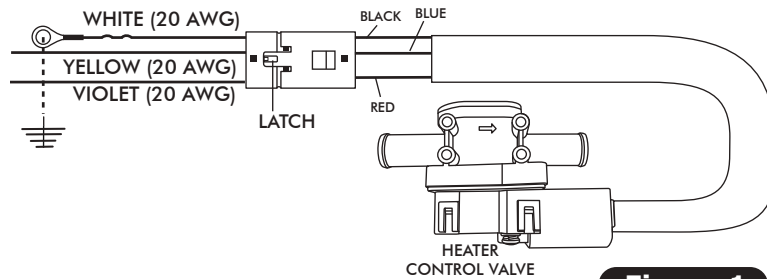

Figure 1

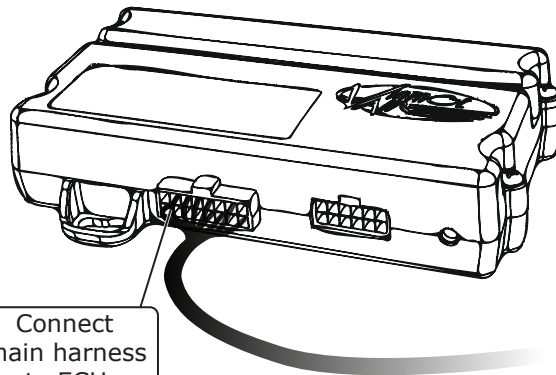

Figure 2

Locate twisted bundle of green and orange strand wires joined together with a connector

Locate color matching twisted bundle wires from main harness nearest to ECU connector and connect both connectors together

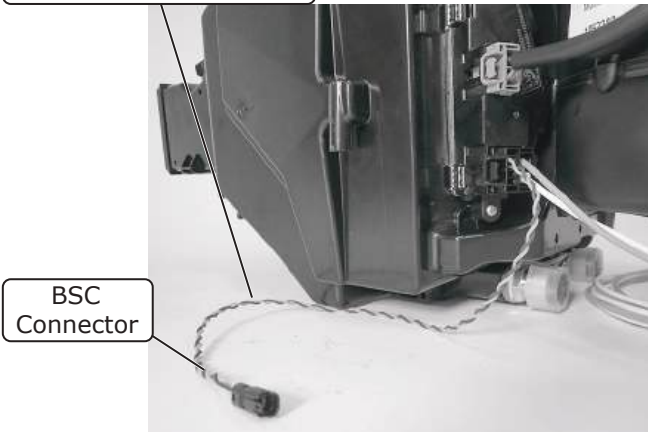

Photo 1

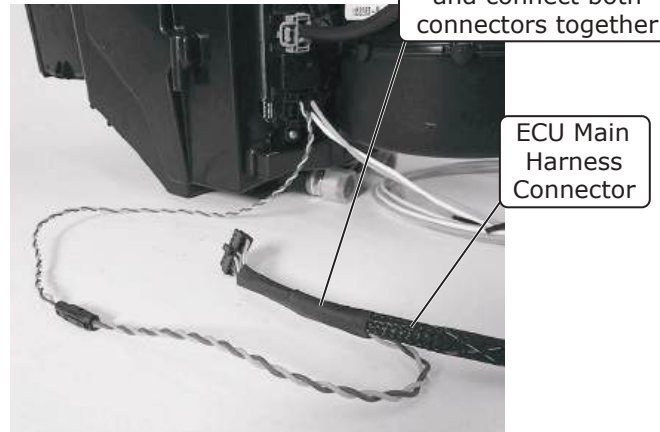

Photo 2



www.vintageair.com

Engine Compartment Wiring

NOTE: The following connections are critical to the performance of the system. Before making connections, refer to the Quality Crimp Guidelines, Page 35.

1. Route power and ground wires toward the battery (See Photo 1, below).
2. Install the supplied heat shrink over the 12 AWG orange standard fuse holder assembly wire and crimp it to the 12 AWG orange wire from the main wiring harness (See Photo 2, below). Slide the heat shrink over the crimp, then apply heat.
3. Install the supplied heat shrink over the 16 AWG black mini fuse holder assembly wire and crimp it to the 16 AWG red wire from the main wiring harness (See Photo 3, below). Slide the heat shrink over the crimp, then apply heat.
4. Install the fuses into the holders (See Photos 4 and 5, below).
5. Install the supplied heat shrink over the white ground wires, then crimp on the supplied ring terminals (See Photo 6, below). Slide the heat shrink over the crimps, then apply heat. **NOTE: Both white wires can be crimped to the larger ring terminal. Install the heat shrink, then strip the wires, twist them together and trim to length. Crimp on the ring terminal, then slide the heat shrink over and apply heat (See Photos 7 and 8, below).**



Route power and ground wires toward battery

Photo 1

Crimp 12 AWG orange fuse holder wire to 12 AWG orange wire from main wiring harness



Photo 2

Install heat shrink over 12 AWG orange standard fuse holder assembly wire

Crimp 16 AWG black fuse holder wire to 16 AWG red wire from main wiring harness



Photo 3

Install heat shrink over 16 AWG black standard fuse holder assembly wire

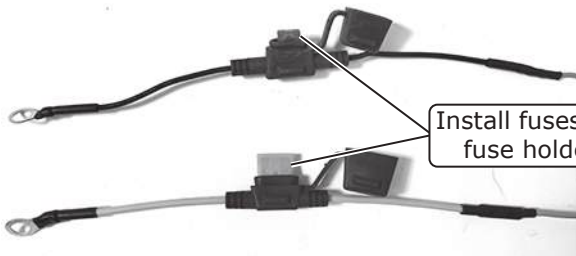

Install fuses into fuse holders

Photo 4



Both white ground wires can be crimped together. Install heat shrink, then strip wires, twist together and trim to length.

Photo 5

Install heat shrink over white ground wires, then crimp on ring terminals

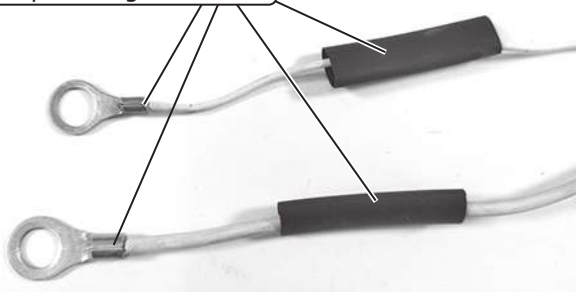

Photo 6

Crimp on ring terminal, then slide heat shrink over and apply heat



Photo 7

Photo 8



www.vintageair.com

Engine Compartment Wiring (Cont.)

6. Connect the ground wire ring terminals to the negative battery terminal connector (See Photos 9 and 10, below).
7. Connect the positive wire ring terminals to the positive battery terminal connector (See Photos 11 and 12, below). **NOTE: Do not connect power until the installation is completed.**
8. Wiring completed (See Photo 13, below).

Connect ground wire ring terminals to negative battery terminal
NOTE: Either connection application can be used.

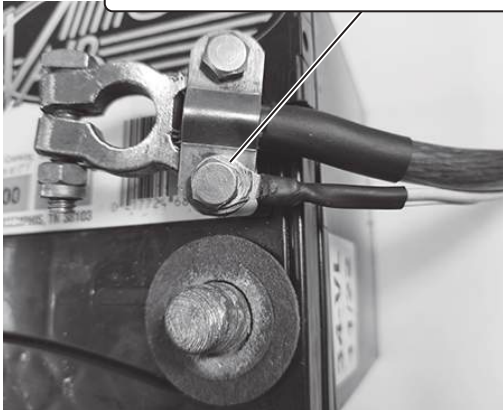

Photo 9

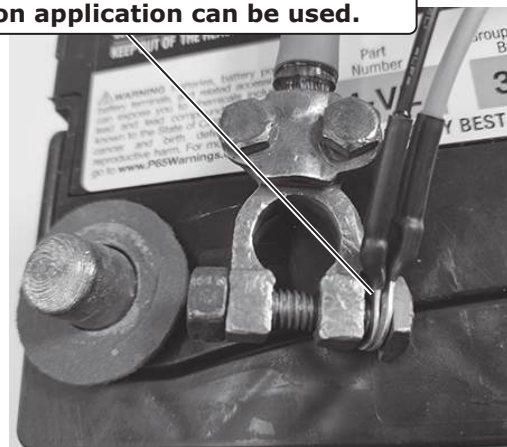

Photo 10

Connect power wire ring terminals to positive battery terminal
NOTE: Either connection application can be used.



Photo 11



NOTE: Do not connect power until installation is completed.

Photo 12



Completed Installation Shown

Photo 13



www.vintageair.com

Final Steps: Installation Check

Installation Check	
ITEM TO CHECK	Procedure
<input type="checkbox"/>	<p>ECU</p> <p>If no blinking is observed after 1 minute of turning the ignition on, go to the next check.</p> <p>If repetitive blinking is observed, go to the Advanced Diagnostics Section to diagnose.</p>
<input type="checkbox"/>	<p>Blower speed control</p> <p>Set the blower speed control to OFF, <u>confirm that the blower is off</u>.</p> <p>Position the blower speed control to LOW then MEDIUM and then HIGH. <u>At each setting confirm that the blower speed increases</u>, do this by feeling for the amount of air coming from the unit and hearing the blower speed increase.</p>
<input type="checkbox"/>	<p>Mode control</p> <p>Set the MODE control to the DASH position. <u>Confirm that air is being blown at the dash vents</u>.</p> <p>Set the MODE control to the FLOOR position. <u>Confirm that air is being blown at the floor vents</u>.</p> <p>Set the MODE control to the DEFROST position. <u>Confirm that all air is being blown from the defrost vents</u></p> <p>If heater lines are installed:</p> <p>Set the MODE control to the DASH position. Set the TEMP control to the MAX HEAT position. <u>Confirm that HOT air is coming from the dash vents</u>.</p>
<input type="checkbox"/>	<p>Temperature control</p> <p>If system is charged:</p> <p>Set the TEMP control to the MAX COOL position. <u>Confirm that COLD air is coming from the dash vents</u>.</p> <p>Also <u>confirm that the compressor "clicks" on</u> when adjusting the TEMP control from the MAX HEAT position to the MAX COOL position.</p>
<input type="checkbox"/>	<p>AC Indicator (If applicable)</p> <p>While the MODE control is set to the DASH position, and the TEMP control is set to the MAX COOL/MIN HEAT position, <u>confirm that the blue AC Indicator light is on</u>.</p>
<input type="checkbox"/>	<p>Backlight (If applicable)</p> <p>If your control panel has backlight capabilities and has been wired, turn the dash lamp on and <u>confirm that the AC panel's legend is lit</u>.</p>
<input type="checkbox"/>	<p>Fittings</p> <p>Verify AC and Heater fittings are all tight.</p>



www.vintageair.com

Final Steps: Completing the Install

- 1.** Install duct hoses as shown in Duct Hose Routing, Page 33.
- 2.** Route A/C wires (12 volt/grounds/binary switch/heater valve) through 3/8" grommet.
- 3.** Install control panel assembly. Refer to control panel instructions.
- 4.** Plug the wiring harnesses into the ECU module on the sub case. Wire according to wiring diagrams on Pages 36 and 37.
- 5.** Install glove box as shown in Glove Box Installation, Page 34.
- 6.** Install glove box door (hardware specified in R & D tech notes).
- 7.** Reinstall all previously removed items.
- 8.** Fill radiator with at least a 50/50 mixture of approved antifreeze and distilled water. It is the owner's responsibility to keep the freeze protection at the proper level for the climate in which the vehicle is operated. Failure to follow antifreeze recommendations will cause heater core to corrode prematurely and possibly burst in A/C mode and/or freezing weather, voiding your warranty.
- 9.** Double check all fittings, brackets and belts for tightness.
- 10.** Vintage Air recommends that all A/C systems be serviced by a licensed automotive A/C technician.
- 11.** Evacuate the system for a minimum of 45 minutes prior to charging, and perform a leak check prior to servicing.
- 12.** Charge the system to the capacities stated on Page 4 of this instruction manual.
- 13.** See Operation of Controls procedures on Page 38.



www.vintageair.com

Duct Hose Routing

NOTE: For the system to function optimally, the duct hoses must be routed as directly as possible, taking care to avoid kinks, sharp bends and unnecessary length. Vintage Air supplies duct hoses in continuous lengths that will need to be cut to size depending on application. Before cutting, familiarize yourself with the installation instructions and verify the routing will work with your application. For custom hose routing, additional hose may be needed and can be purchased from Vintage Air.

1. Stretch the duct hose until there is no slack, measure, mark and cut hose to size (See Photo 1, below).

Stretch, measure, mark and cut hose to size



Photo 1

Disclaimer: Before cutting duct hose to length, verify the routing will work for your application.

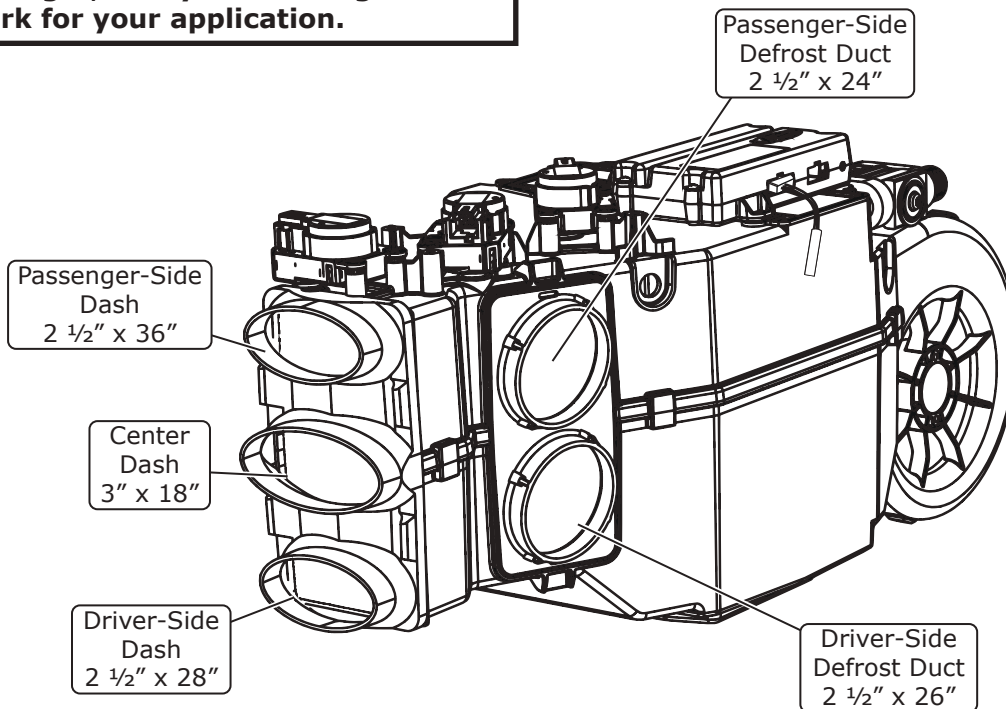

NOTE: ECU must be placed away from water and humidity, and also be accessible for servicing. If relocating, connectors must be positioned towards the bottom.

Position connectors towards bottom



www.vintageair.com

Glove Box Installation

1. Begin by installing the provided U-nuts on the dash as shown in Photo 1, below. When installing the included glove box, the metal OEM glove box bracket will not be reused (See Photo 2, below).
2. Insert the provided glove box as shown in Photos 3 and 4, below. **NOTE: The glove box will be a snug fit, top corners may need to be worked into place to sit flush in the opening.**
3. Insert the glove box door hinge between the glove box and the dash (See Photos 5 and 6, below).
4. Install the bottom center screw, then the top screws on the left and right sides, leave loose. Be sure all holes line up then install the other (4) screws and tighten (See Photos 7 and 8, below).
5. The glove box striker may need to be adjusted. To adjust, loosen the (2) screws on the door and slide the striker in or out as needed (See Photo 9, below).

Install provided U-nuts on dash

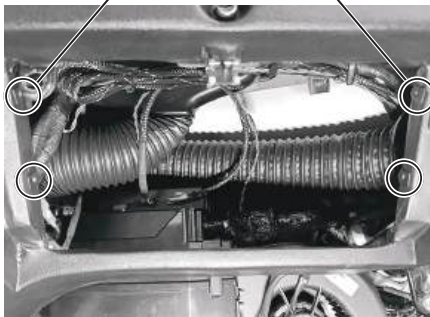

Photo 1

Metal OEM glove box bracket will not be reused



Photo 2

Insert provided glove box

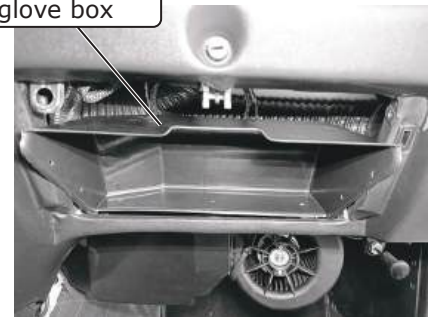

Photo 3

Insert provided glove box

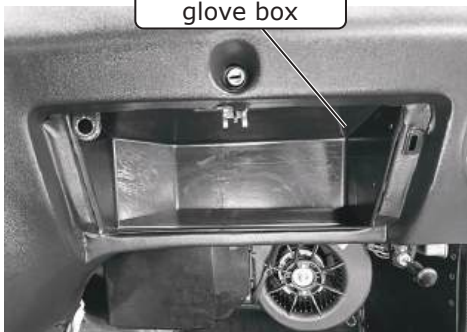

Photo 4

Insert glove box door hinge arm first

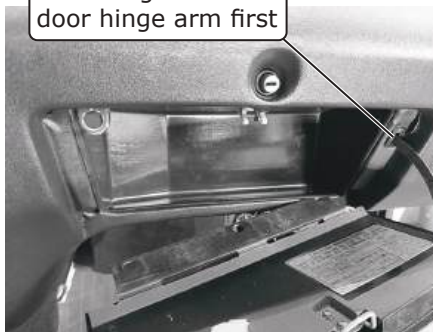

Photo 5

Door hinge slips under glove box



Photo 6

Install top screws

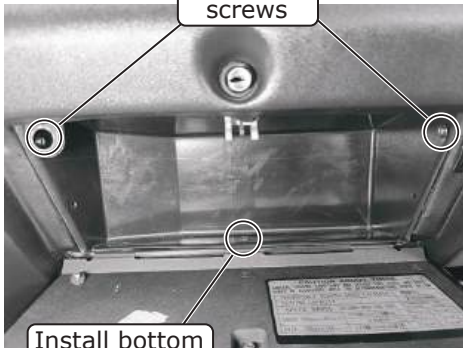

Photo 7

Install bottom center screw

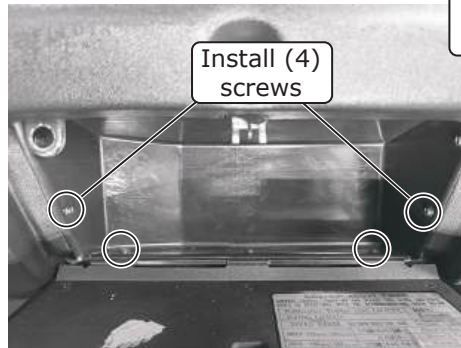

Photo 8

Install (4) screws

To adjust striker, loosen (2) screws on door

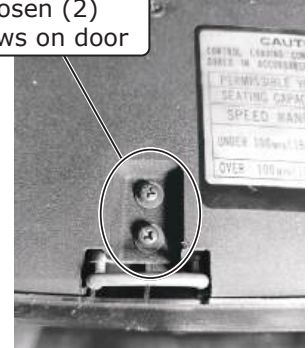

Photo 9

Quality Crimp Guideline

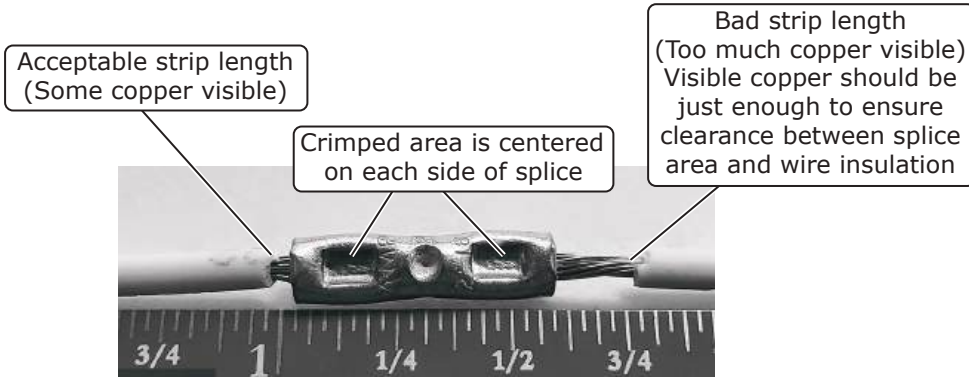

Photo 1

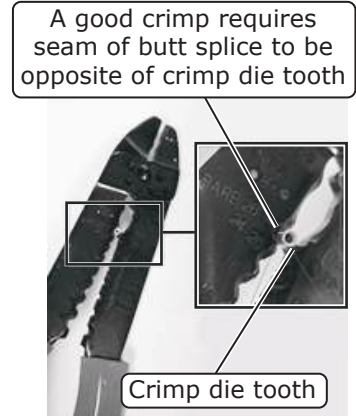

Photo 2

Good Ring Terminal Crimp Bad Ring Terminal Crimp

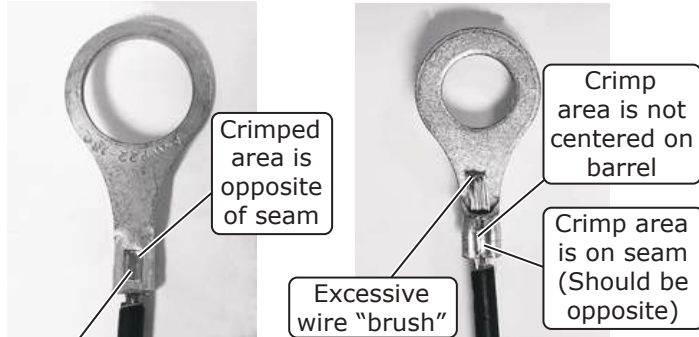

Photo 3

Photo 4



Photo 5

Crimp area is centered on barrel

Use a ratcheting crimp tool for insulated barrel terminals when crimping the provided female insulated terminal. Ensure terminal is inserted in appropriate position before crimping.

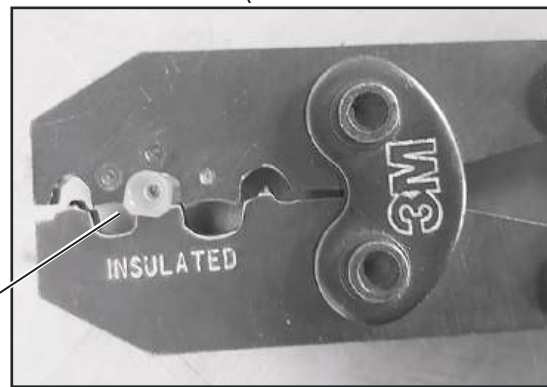
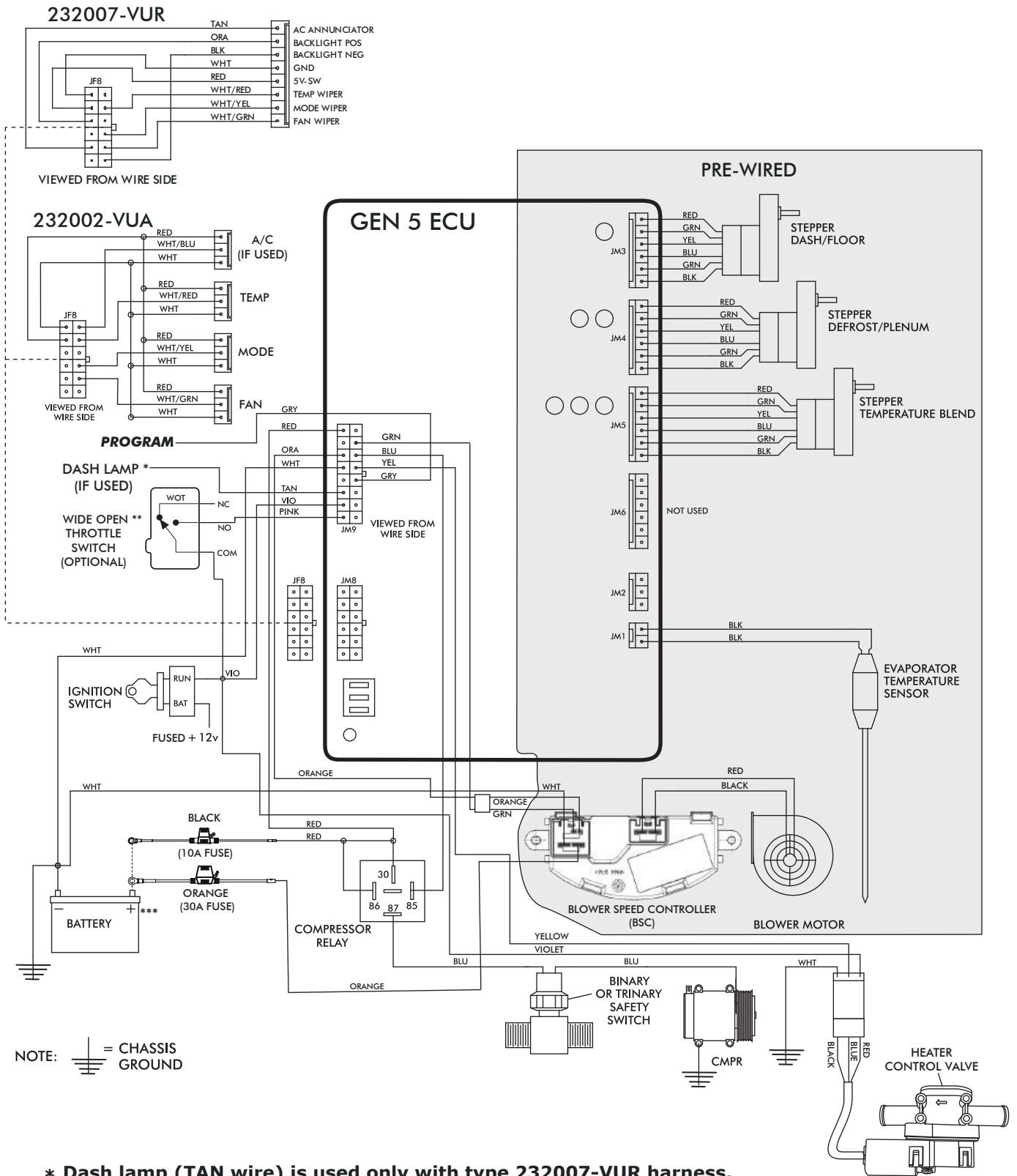

Photo 5a



www.vintageair.com

Gen 5 Wiring Diagram



NOTE: = CHASSIS GROUND

- * Dash lamp (TAN wire) is used only with type 232007-VUR harness.
- ** Wide open throttle switch contacts close only at full throttle, which disables A/C compressor.
- *** Install fuse assemblies at or as near to the battery as possible.



www.vintageair.com

Gen 5 Wiring Instructions

WIRING HARNESS (231505) ↓

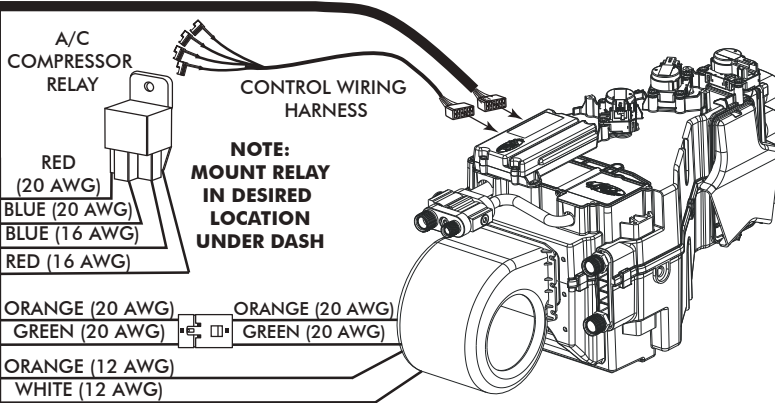

NOTE:
MOUNT RELAY
IN DESIRED
LOCATION
UNDER DASH

Ignition Switch:
Using provided butt splice (PN 226004), connect the 20 AWG violet wire to a 5A fused and switched 12V source such as Key On.

Wide Open Throttle Switch (Optional):
If a wide open throttle switch is required, connect the 20 AWG pink wire to a normally open switch that, when closed, connects a fused and switched 12V source to the pink wire. See Gen 5 wiring diagram for an example.

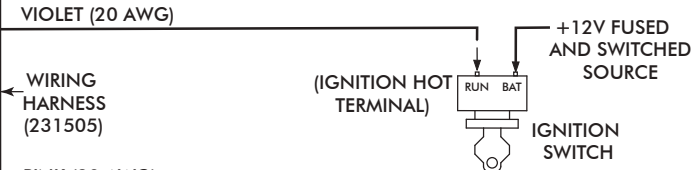

Dash Light (Optional):
If using a Vintage Air control panel with back light, connect the 20 AWG tan wire to the vehicle's dash back light 0-12V using provided butt splice (PN 226004).

WIRING HARNESS (232020) →

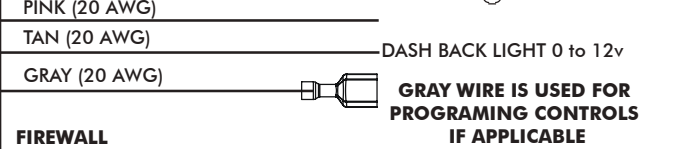

Heater Control Valve:
Connect the Violet/Yellow/White twisted branch with 3 position connector into the heater control valve connector. Ensure that the mating latch is fully seated.

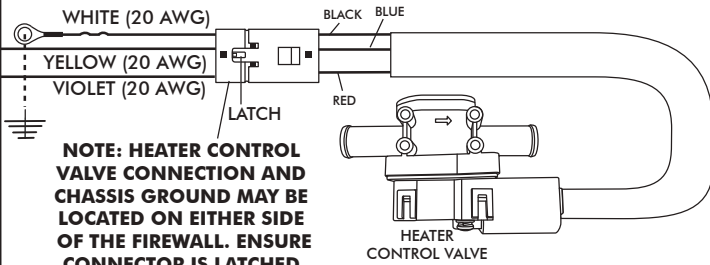

Binary/Trinary & Compressor:
Binary Switch: Terminate provided insulated female terminal (PN 23172-VUW) to the blue 16 AWG wire. Connect as shown.
Trinary Switch: Connect according to trinary switch wiring diagram.

WIRING HARNESS (232020) →

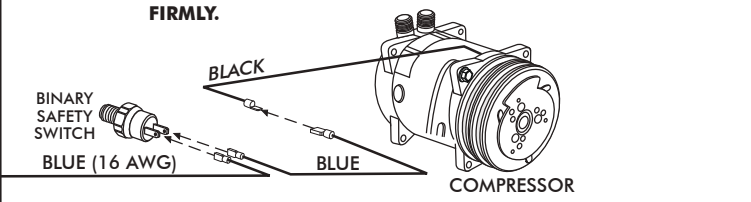

Battery Connections:
ECU Ground: Terminate provided ring terminal (PN 226110) to 20 AWG white wire from the 231505 wire assembly and install at battery.
ECU PWR: Terminate provided fuse assembly with black leads (PN 233012) to the 16 AWG red wire from the 231505 wire assembly. Install provided 10A Red Mini Fuse (PN 226118). Install at battery.
Blower Speed Controller (BSC) Ground: Terminate provided ring terminal (PN 226111) to 12 AWG white wire from the 232020 wire assembly and install at battery.
Blower Speed Controller (BSC) PWR: Terminate provided fuse assembly with orange leads (PN 233008) to the 12 AWG orange wire from the 232020 wire assembly. Install provided 30A Green ATO/ATC Fuse (PN 226125). Install at battery.

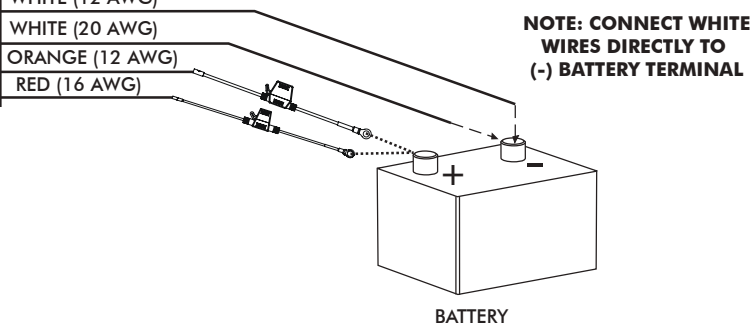



www.vintageair.com

Operation of Controls

On Gen IV or Gen 5 systems with three lever/knob controls, the temperature control toggles between heat and A/C operations. To activate A/C, move the temperature lever/knob all the way to cold and then back it off to the desired vent temperature. For heat operation, move the temperature lever/knob all the way to hot and then adjust to the desired vent temperature. The blower will momentarily change speed, each time you toggle in and out of heat and A/C operations, to indicate the change.

Blower Speed

This lever/knob controls blower speed, from OFF to HI.

Mode Control

This lever/knob controls the mode positions, from DASH to FLOOR to DEFROST, with a blend in between.

Temperature Control

This lever/knob controls the temperature, from HOT to COLD.

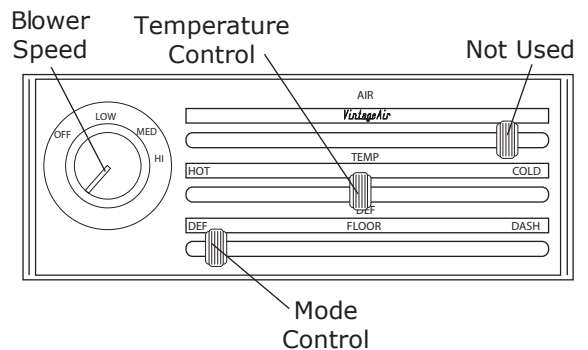

A/C Operation

Blower Speed

Adjust to desired speed.

Mode Control

Adjust to desired mode position (DASH position recommended).

Temperature Control

For A/C operation, adjust to coldest position to engage compressor (adjust between HOT and COLD to reach desired temperature).

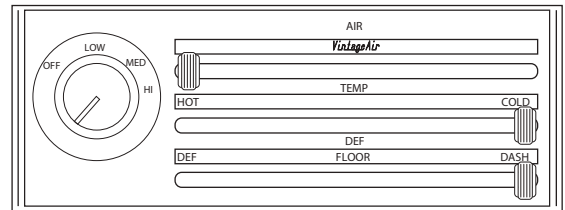

Heat Operation

Blower Speed

Adjust to desired speed.

Mode Control

Adjust to desired mode position (FLOOR position recommended).

Temperature Control

For maximum heating, adjust to hottest position (adjust between HOT and COLD to reach desired temperature).

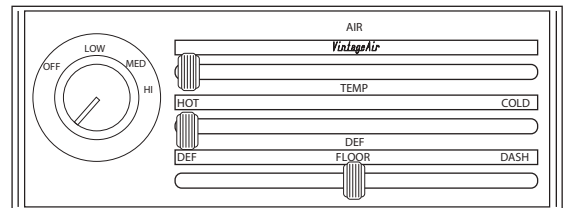

Defrost/De-fog Operation

Blower Speed

Adjust to desired speed.

Temperature Control

Adjust to desired temperature.

Mode Control

Adjust to DEFROST position for maximum defrost, or between FLOOR and DEFROST positions for a bi-level blend (Compressor is automatically engaged).

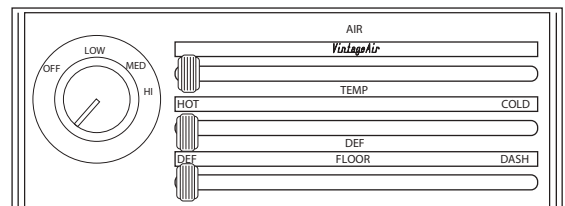



www.vintageair.com

Troubleshooting Guide

This printed troubleshooting guide is our basic guide that covers common installation problems. To see our advanced diagnostics and troubleshooting guide, please refer to the following page for instructions on how to download the complete guide.

WARNING: While troubleshooting the system, never probe connector terminals from the front mating side, only back probe.
WARNING: While troubleshooting the system, never use automotive check lights.

Symptom	Condition	Checks	Actions	Notes
1. Blower stays on high speed with ignition on.	No other functions work.	Check for damaged pins or wires in the control panel wire assembly and mating header at ECU.	If found damaged, replace wire assembly or ECU.	If fuse continues to blow, there is a serious problem in the wiring. Check all wiring and ensure the wire is not damaged and shorting out along its route.
	All other functions work.	Check for a bad ECU GND. Check for damaged pins or wires in the control panel wire assembly and mating header at ECU. Check if Blower power fuse is blown. Check for a bad ECU GND.	If found damaged, replace wire assembly or ECU. Replace fuse. Repair connection.	
2. Compressor will not turn on (All other functions work).	System is not charged.	System must be charged for compressor to engage.	Charge system.	Danger: Never bypass safety switch with engine running. Serious injury can result.
	System is charged.	Check for faulty A/C potentiometer or associated wiring (not applicable to 3-pot controls).	Check continuity to ground on white control head wire. Check for 5V on red control head wire.	To check for proper pot function, check voltage at white/red wire. Voltage should be between 0V and 5V, and will vary with pot lever position.
		Check for disconnected or faulty thermistor.	Check 2-pin connector at ECU housing.	Disconnected or faulty thermistor will cause compressor to be disabled.
3. Compressor will not turn off (All other functions work).	System is charged.	Check for faulty A/C potentiometer or associated wiring.	Repair or replace pot/control wiring.	Red wire at A/C pot should have approximately 5V with ignition on. White wire will have continuity to chassis ground. White/Red wire should vary between 0V and 5V when lever is moved up or down.
		Check for faulty A/C relay.	Replace relay.	



www.vintageair.com

Troubleshooting Guide (Cont.)

Symptom	Condition	Checks	Actions	Notes
4. System will not turn on, or runs intermittently.	Works when engine is not running; shuts off when engine is started	Noise interference from either ignition or alternator.	Install capacitors on ignition coil and alternator. Ensure good ground at all points. Relocate coil and associated wiring away from ECU and ECU wiring. Check for burned or loose plug wires.	Ignition noise (radiated or conducted) will cause the system to shut down due to high voltage spikes. If this is suspected, check with a quality oscilloscope. Spikes greater than 16V will shut down the ECU. Install a radio capacitor at the positive post of the ignition coil (see radio capacitor installation bulletin). A faulty alternator or worn out battery can also result in this condition.
	Will not turn on under any conditions.	Verify connections on power lead, ignition lead, and both white ground wires.	Check for power at ECU, and confirm ignition is being applied to ECU properly.	
		Verify battery voltage is greater than 10 volts and less than 16 while engine is running.	Verify proper meter function by checking the condition of a known good battery.	
5. Loss of mode door function.	No mode change at all.	Check for damaged mode switch or potentiometer and associated wiring.		
	Blower turns on and off rapidly.	Battery voltage is at least 12V. Battery voltage is less than 12V.	Ensure all system grounds and power connections are clean and tight. Charge battery.	System shuts off blower at 10V. Poor connections or weak battery can cause shutdown at up to 11V.
7. Erratic functions of blower, mode, temp, etc.		Check for damaged switch or pot and associated wiring.	Repair or replace.	

Advanced Diagnostics and Troubleshooting Guide

If after referencing the Troubleshooting Guide, the issue is not resolved, move to The Advanced Diagnostics and Troubleshooting Guide that covers the following:

- **ECU Diagnostics Codes**
 1. **ECU Blink Sequence**
 2. **Firmware Version Number**
 3. **ECU Model Number**
 4. **ECU Start-Up Blink Sequence**
 5. **Diagnostic Codes**
- **Complete Advanced Troubleshooting Guidelines**

Access the latest version of the Advanced Diagnostics and Troubleshooting Guide by scanning the following QR code on your mobile device:



You can also access the guide by typing the following address into your web browser:

https://www.vintageair.com/instructions_pdf/905000.pdf



www.vintageair.com

Packing List: Evaporator Kit (589025)

No.	Qty.	Part No.	Description
1.	1	765200	Gen 5 Magnum Max Module with 404 ECU
2.	1	789025	Accessory Kit

Checked By: _____
Packed By: _____
Date: _____

1



**Gen 5 Magnum Max
Module with 404 ECU
765200**

2

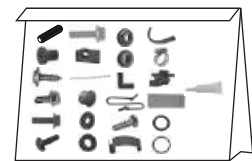
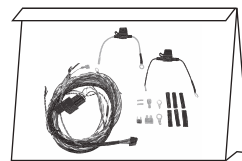
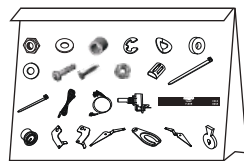
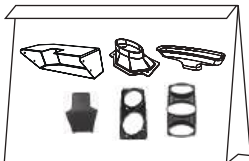
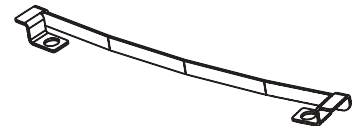
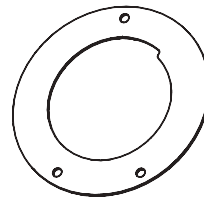
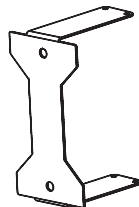
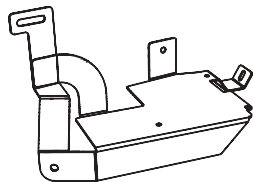
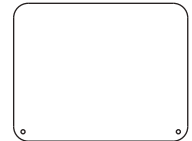
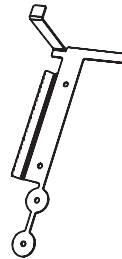
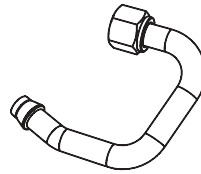

**Accessory Kit
789025**

**NOTE: Images may not depict actual parts and quantities.
Refer to packing list for actual parts and quantities.**