



1962-65 Chevrolet Nova

with and without Factory Air
Gen 5 Evaporator Kit
(561296)



18865 Goll St. San Antonio, TX 78266
Phone: 800-862-6658
Sales: sales@vintageair.com
Tech Support: tech@vintageair.com
www.vintageair.com



www.vintageair.com

Table of Contents

Cover.....	1
Table of Contents.....	2
Packing List/Parts Disclaimer.....	3
Information Page.....	4
Wiring Notice.....	5
Engine Compartment Disassembly, Condenser Assembly and Installation, Compressor and Brackets.....	6
Passenger Compartment.....	7
Defrost Duct/Fresh Air Cap Installation.....	8
OEM Wiper Arm Replacement, DSE Detroit Speed Wiper Arm Modification.....	9
Firewall Cover Installation.....	10
Lubricating O-rings & Fitting Torque Specs, Properly Seated O-ring Land, Evaporator Preparation..	11
Evaporator Preparation (Cont.).....	12
Passenger Compartment Wiring.....	13
Evaporator Installation.....	14
A/C Hose Installation	15
Heater Hose & Heater Control Valve Installation, A/C and Heater Hose Routing.....	16
Drain Hose Installation, Control Panel Installation.....	17
Engine Compartment Wiring.....	18-19
Under Dash Louver Installation.....	20
Final Steps: Installation Check.....	21
Final Steps: Completing the Install.....	22
Duct Hose Routing.....	23
Quality Crimp Guideline.....	24
Gen 5 Wiring Diagram.....	25
Gen 5 Wiring Connection Instruction.....	26
Operation of Controls.....	27
Troubleshooting Guide.....	28
Troubleshooting Guide (Cont.), Advanced Diagnostics and Troubleshooting Guide.....	29
Packing List.....	30



www.vintageair.com

Packing List: Evaporator Kit (561296)

No.	Qty.	Part No.	Description
1.	1	765100	Gen 5 Magnum Max Module with 404 ECU
2.	1	781296	Accessory Kit

**** Before beginning installation, open all packages and check contents of shipment. Please report any shortages directly to Vintage Air within 15 days. After 15 days, Vintage Air will not be responsible for missing or damaged items.**

1



Gen 5 Magnum Max
Module with 404 ECU
765100

2

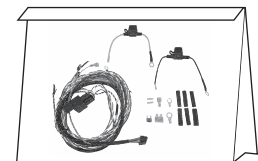
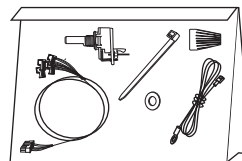
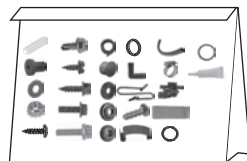
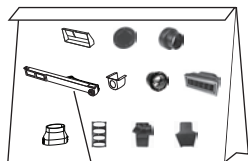
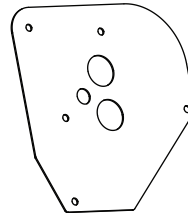
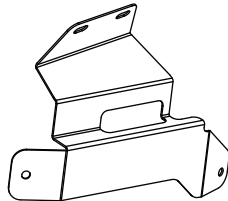
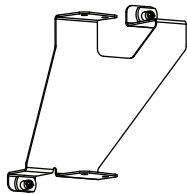

592663

Accessory Kit
781296

NOTE: Images may not depict actual parts and quantities. Refer to packing list for actual parts and quantities.



www.vintageair.com

Important Notice—Please Read

For Maximum System Performance, Vintage Air Recommends the Following:

NOTE: Vintage Air systems are designed to operate with R134a refrigerant only. Use of any other refrigerant could damage your A/C system and/or vehicle, and possibly cause a fire, in addition to potentially voiding the warranties of the A/C system and its components.

Refrigerant Capacities:

Vintage Air System: 1.8 lbs. (28.8 oz.) or 816 grams of **R134a**, charged by weight with a quality charging station or scale. **NOTE: Use of the proper type and amount of refrigerant is critical to system operation and performance.**

Other Systems: Consult manufacturer's guidelines.

Lubricant Capacities:

New Vintage Air-Supplied Sanden Compressor: No additional oil needed (Compressor is shipped with proper oil charge).

All Other Compressors: Consult manufacturer (Some compressors are shipped dry and will need oil added).

Safety Switches

Your Vintage Air system is equipped with a binary pressure safety switch. A binary switch disengages the compressor clutch in cases of extreme low pressure conditions (refrigerant loss) or excessively high head pressure (406 PSI) to prevent compressor damage or hose rupture. A trinary switch combines Hi/Lo pressure protection with an electric fan operation signal at 254 PSI, and should be substituted for use with electric fans. Compressor safety switches are extremely important since an A/C system relies on refrigerant to circulate lubricant.

Service Info:

Protect Your Investment: Prior to assembly, it is critical that the compressor, evaporator, A/C hoses and fittings, hardlines, condenser and receiver/drier remain capped. Removing caps prior to assembly will allow moisture, insects and debris into the components, possibly leading to reduced performance and/or premature failure of your A/C system. This is especially important with the receiver/drier.

Additionally, when caps are removed for assembly, **BE CAREFUL!** Some components are shipped under pressure with dry nitrogen.

Evacuate the System for 35-45 Minutes: Ensure that system components (Drier, compressor, evaporator and condenser) are at a temperature of at least 85°F. On a cool day, the components can be heated with a heat gun **or** by running the engine with the heater on before evacuating. Leak check and charge to specifications.

Bolts Passing Through Cowl and/or Firewall:

To ensure a watertight seal between the passenger compartment and the vehicle exterior, for all bolts passing through the cowl and/or firewall, Vintage Air recommends coating the threads with silicone prior to installation.

Heater Hose (not included with this kit):

Heater hose may be purchased from Vintage Air (Part#31800-VUD) or your local parts retailer. Routing and required length will vary based on installer preference.



www.vintageair.com

Important Wiring Notice—Please Read

Some vehicles may have had some or all of their radio interference capacitors removed. There should be a capacitor found at each of the following locations:

- 1. On the positive terminal of the ignition coil.**
- 2. If there is a generator, on the armature terminal of the generator.**
- 3. If there is a generator, on the battery terminal of the voltage regulator.**

Most alternators have a capacitor installed internally to eliminate what is called “whining” as the engine is revved. If whining is heard in the radio, or just to be extra cautious, a radio interference capacitor can be added to the battery terminal of the alternator.

It is also important that the battery lead is in good shape and that the ground leads are not compromised. There should be a heavy ground from the battery to the engine block, and additional grounds to the body and chassis.

If these precautions are not observed, it is possible for voltage spikes to be present on the battery leads. These spikes come from ignition systems and charging systems, and from switching some of the vehicle’s other systems on and off. Modern computer-operated equipment can be sensitive to voltage spikes on the power leads, which can cause unexpected resets, strange behavior and/or permanent damage.

Vintage Air strives to harden our products against these types of electrical noise, but there is a point where a vehicle’s electrical system can be degraded so much that nothing can help.

Radio interference capacitors should be available at most auto and truck parts suppliers. They typically are cylindrical in shape, a little over an inch long and a little over a half-inch in diameter, and they have a single lead coming from one end of the cylinder with a terminal on the end of the wire, as well as a mounting clip which is screwed into a good ground on the vehicle. The specific value of the capacitance is not too significant in comparison to ignition capacitors that are matched with the coil to reduce pitting of the points.

- Care must be taken, when installing the compressor lead, not to short it to ground. The compressor lead must not be connected to a condenser fan or to any other auxiliary device. Shorting to ground or connecting to a condenser fan or any other auxiliary device may damage wiring or the compressor relay, and/or cause a malfunction.
- When installing ground leads on Gen 5 systems, the blower control ground and ECU ground must be connected directly to the negative battery post.
- For proper system operation, the heater control valve must be connected to the ECU.



www.vintageair.com

Engine Compartment Disassembly

NOTE: Before starting the installation, check the function of the vehicle (horn, lights, etc.) for proper operation, study the instructions, illustrations, photos & diagrams.

Perform the following:

1. Remove the battery and battery tray (retain).
2. Drain the radiator, remove the radiator (retain).
3. Evacuate the A/C system if necessary.
4. Remove the OEM condenser and drier (discard) (See Figure 1, below).
5. Remove the OEM compressor and bracket (discard) (See Figure 1, below).
6. Remove the OEM heater hoses (discard) (See Figure 1, below).
7. Remove the OEM A/C hoses and firewall grommet (discard) (See Figure 1, below).
8. Install a 2 5/8" plastic plug in the firewall (A/C cars only) (See Figure 1a, below).

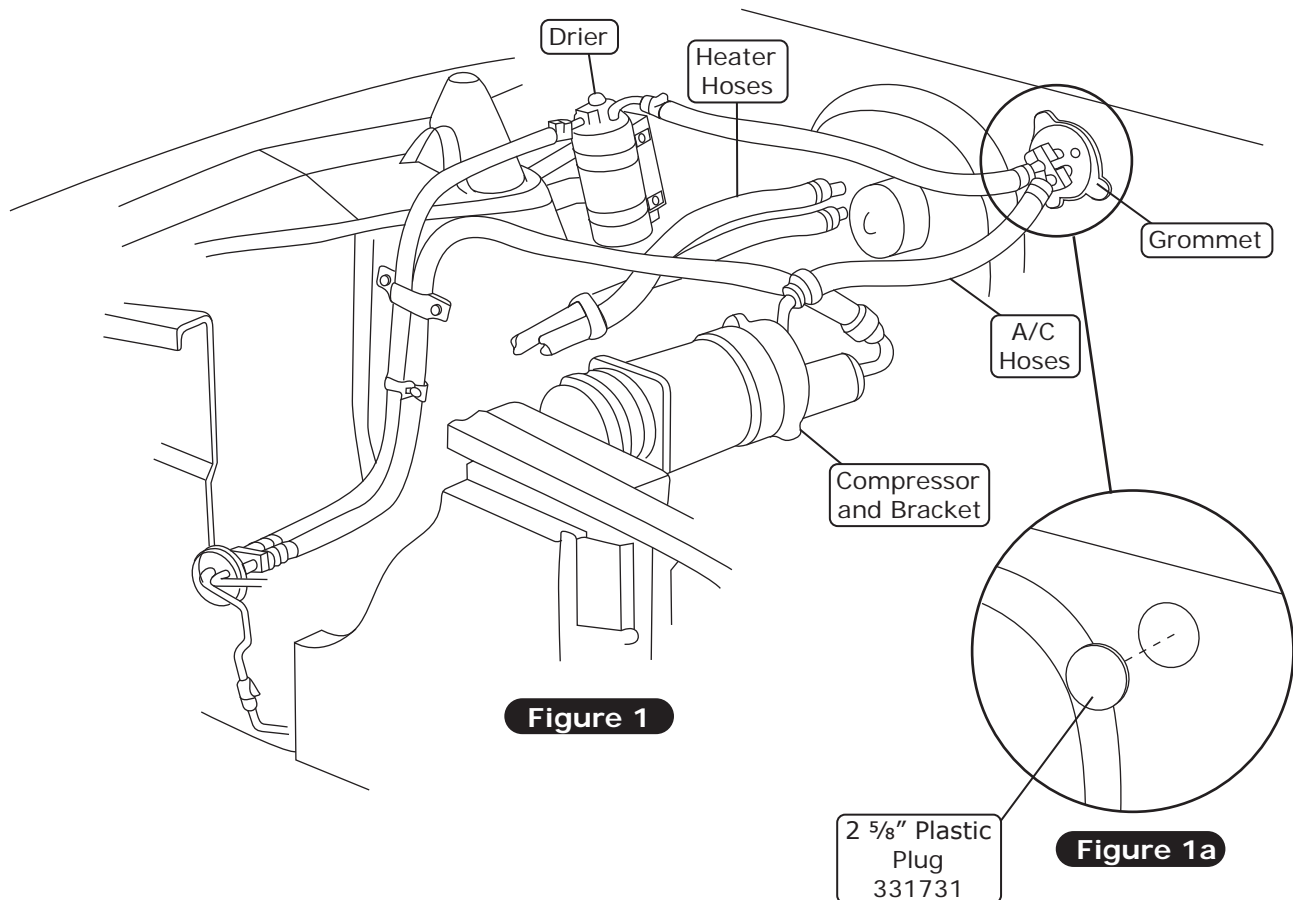

Condenser Assembly and Installation

1. Refer to separate instructions included with the condenser kit to install the condenser.
2. Binary switch installation (Refer to condenser instructions).

Compressor and Brackets

1. Refer to separate instructions included with the bracket kit to install the compressor bracket.



www.vintageair.com

Passenger Compartment Disassembly

Perform the following:

1. Remove the glove box door (retain) (See Figure 1, below).
2. Remove the glove box (discard).
3. Remove the fresh air assembly.
4. Remove the under dash A/C evaporator (if equipped).
5. Disconnect all wires and cables from OEM control panel (retain) (discard).
6. Remove OEM heater assembly (discard), retain screws.
7. Remove (3) control knobs (discard), bezels (retain).
8. Refer to control panel conversion kit instructions for installation of controls.
9. Remove the OEM defrost duct hoses (discard).

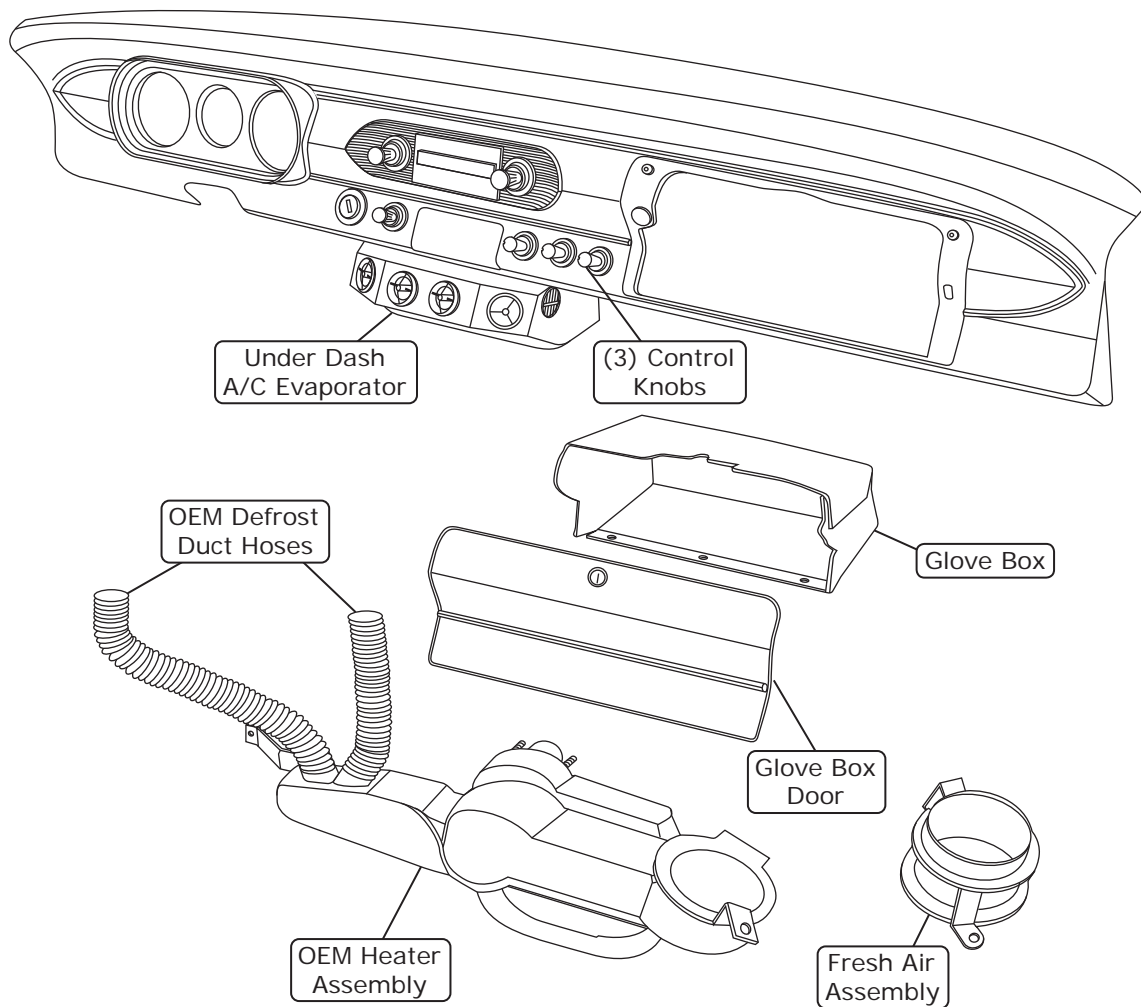

Figure 1



www.vintageair.com

Defrost Duct Hose Adapter/ Fresh Air Cap Installation

1. Install (4) S-clips on the defrost duct hose adapters as shown in Figure 1, below.
2. Install the hose adapters on the defrost ducts as shown in Figure 1, below.
3. Hold the fresh air cap under the cowl, then mark the (3) mounting holes.
4. Drill (3) 1/8" mounting holes under the cowl.
5. Apply a 1/4" bead of silicone around the back side of the fresh air cap as shown in Figure 1, below.
6. Secure the fresh air cap to the fresh air hole using (3) #10 x 1/2" sheet metal screws as shown in Figure 1, below.

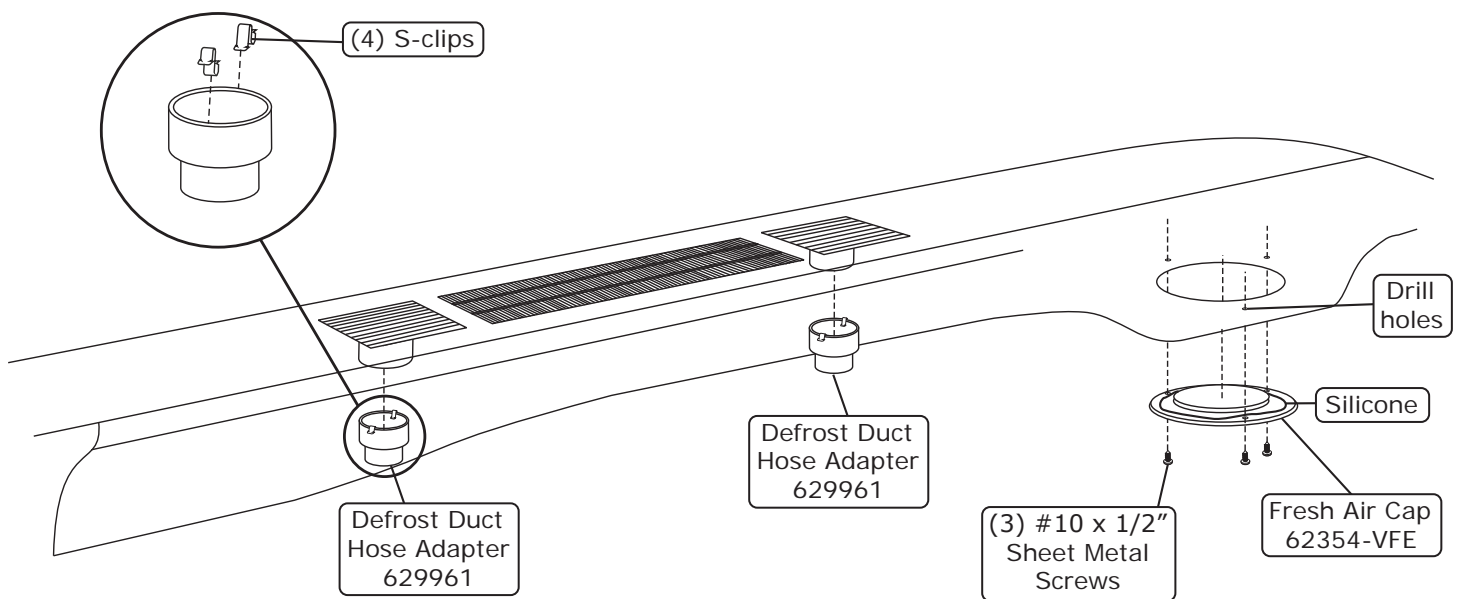

Figure 1



www.vintageair.com

OEM Wiper Arm Replacement

1. Remove the (2) snap rings from the OEM wiper pitman arm and the OEM wiper pivot (See Photo 1, below). Retain clips.
2. Remove the OEM actuator arm.
3. Install the replacement arm onto the pitman arm and pivot (See Photos 2 and 3, below).
4. Replace (2) snap rings onto shafts.

Remove (2) snap rings from OEM wiper pitman arm and OEM wiper pivot



Photo 1

Install replacement arm 642084 onto pitman arm and pivot

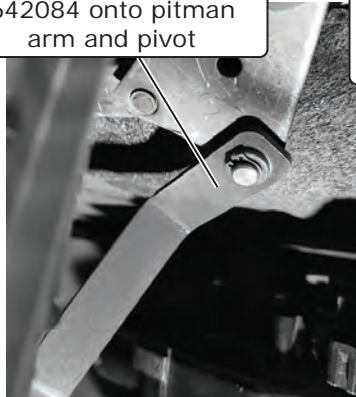

Photo 2

Replace (2) snap rings onto shafts

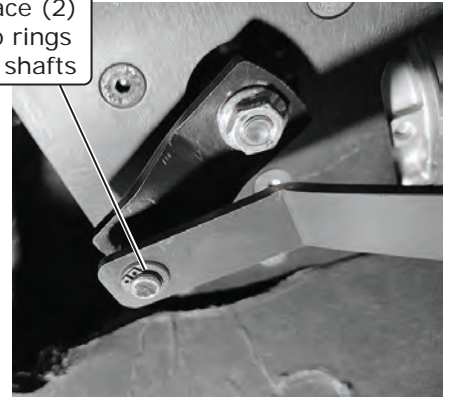

Photo 3

DSE Detroit Speed Wiper Arm Modification

1. Follow Steps 1 and 2 above.
2. Using a bench vice or equivalent, bend tabs an additional 10° as shown in Photo 1, below.
3. Follow Steps 3 and 4 from OEM Wiper Arm Replacement, above.

NOTE: Only bend tabs for DSE wiper arm

Bend tab an additional 10°

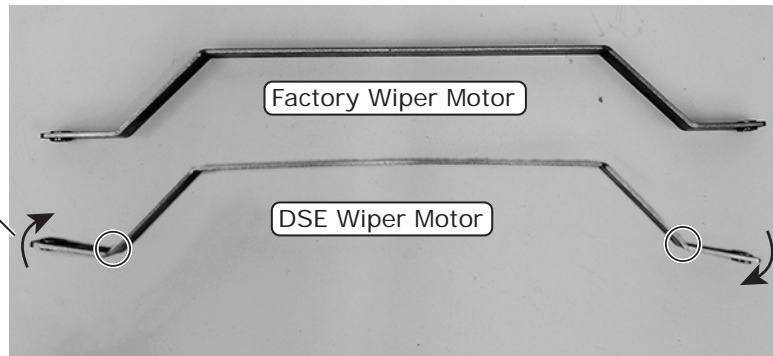

Bend tab an additional 10°

Photo 1

NOTE: Refer to Detroit Speed instruction #DSE F501-147, Page 5, for wiper modification only. Gen 5 systems no longer require plenum modification.



www.vintageair.com

Firewall Cover Installation

1. Enlarge OEM heater holes to 1 1/4" as shown in Figure 1 and 1a, below.
2. Apply a 1/4" bead of silicone around the back side of the firewall cover as shown in Figure 1b.
3. Secure firewall cover to firewall using (2) 1/4-20 x 1" hex bolts with flat washers and nuts (See Figure 1 and 1a, below). **NOTE: Firewall cover installs on inside passenger-side compartment.**
4. Install (2) large grommets into the firewall cover plate (See Figure 1 and 1a, below).

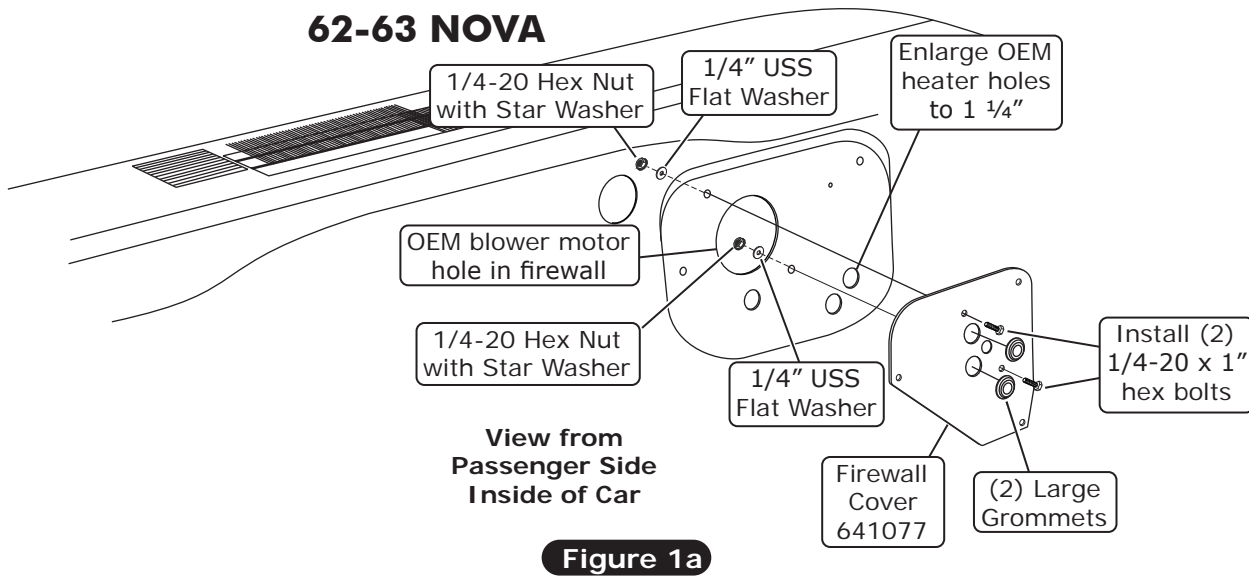
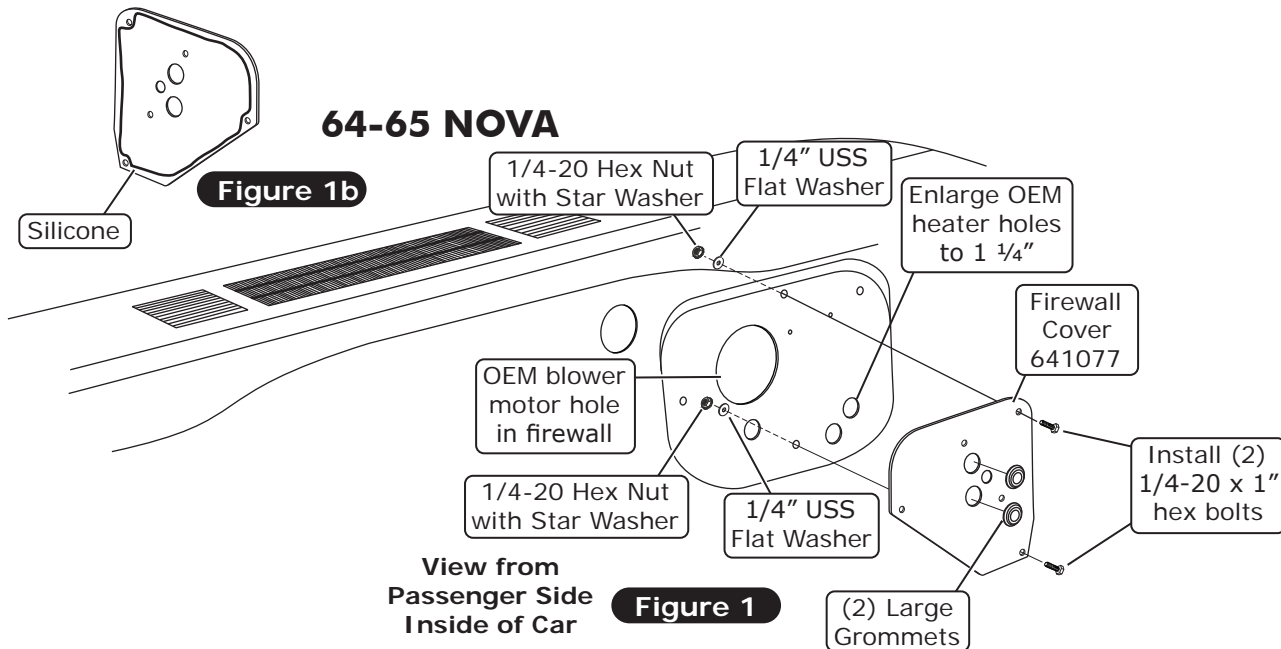



www.vintageair.com

Lubricating O-rings & Fitting Torque Specs

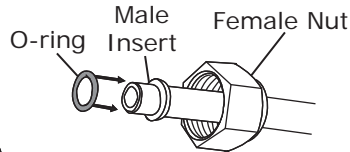
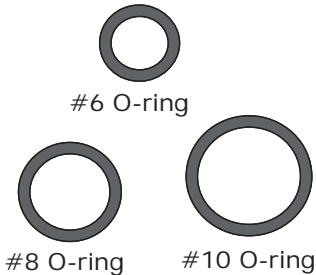

For a proper seal of fittings: Install supplied O-rings as shown and lubricate with refrigerant oil.

Hold with this wrench

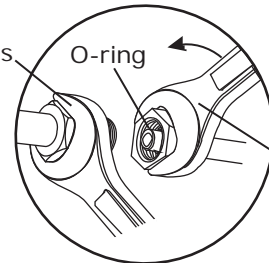

Twist with this wrench

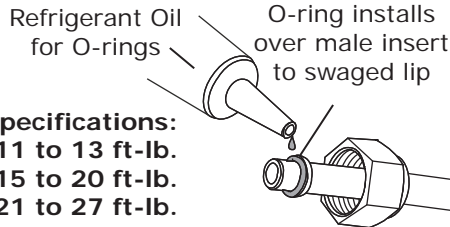

NOTE: Standard torque specifications:
 #6: 11 to 13 ft-lb.
 #8: 15 to 20 ft-lb.
 #10: 21 to 27 ft-lb.

The use of a backup wrench is recommended to reduce the chance of damaging the fittings/hardline.

Properly Seated O-ring Land

When installing a hardline or A/C hose fitting onto the evaporator module, ensure the O-ring land is seated properly (See Photo 1, below). An improperly seated O-ring land (See Photo 2, below) can cause a leak. To properly install the fitting, slide the hardline or A/C hose nut back to expose the O-ring land and seat it onto the evaporator module fitting. Then, slide the hardline or A/C hose nut forward and thread it onto the evaporator module fitting, ensuring the O-ring land does not move or lift.

Properly Seated O-ring Land



Photo 1

Improperly Seated O-ring Land

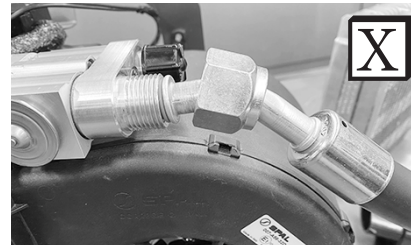

Photo 2

NOTE: Photos shown are for reference only. Fittings may vary depending on kit received.

Evaporator Preparation

1. Install (3) 1/2" plastic plugs into the back of the evaporator module (See Photos 1, 2, 3, below and 4 on Page 12).



Install 1/2" plastic plug into back of evaporator module

Photo 1

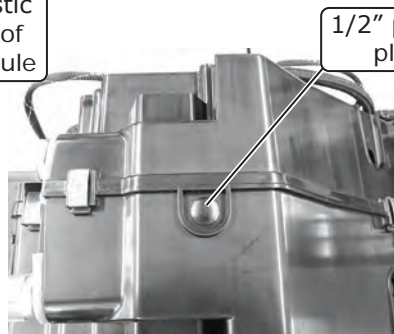

1/2" plastic plug

Photo 2

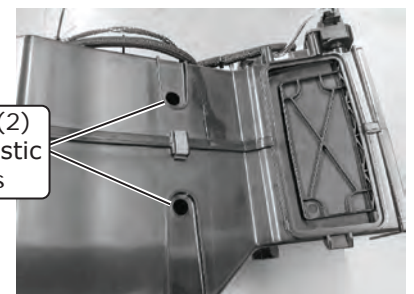

Install (2) 1/2" plastic plugs

Photo 3



www.vintageair.com

Evaporator Preparation (Cont.)

2. Install the dash plenum, defrost plenum, and floor plenum onto the evaporator module using the supplied spring clips as shown in Photos 5 and 6, below.
3. Install the evaporator firewall bracket (640720) onto the evaporator module using (4) #10 x 5/8" screws then install (2) 1/4-20 full-threaded studs onto the bracket as shown in Photos 7, 8, and 9, below.
4. Using properly lubricated #10 O-rings (See Lubricating O-rings & Fitting Torque Specs, Page 11), install the upper heater hardline onto the top heater core port, and the lower heater hardline onto the bottom heater core port as shown in Photos 10 and 11, below. **NOTE: Heater lines should be installed flat against the evaporator mounting bracket as shown in Photos 10 and 11, below, to ensure proper angle of heater hose nipples.**
5. Place evaporator module in passenger floorboard area of vehicle.

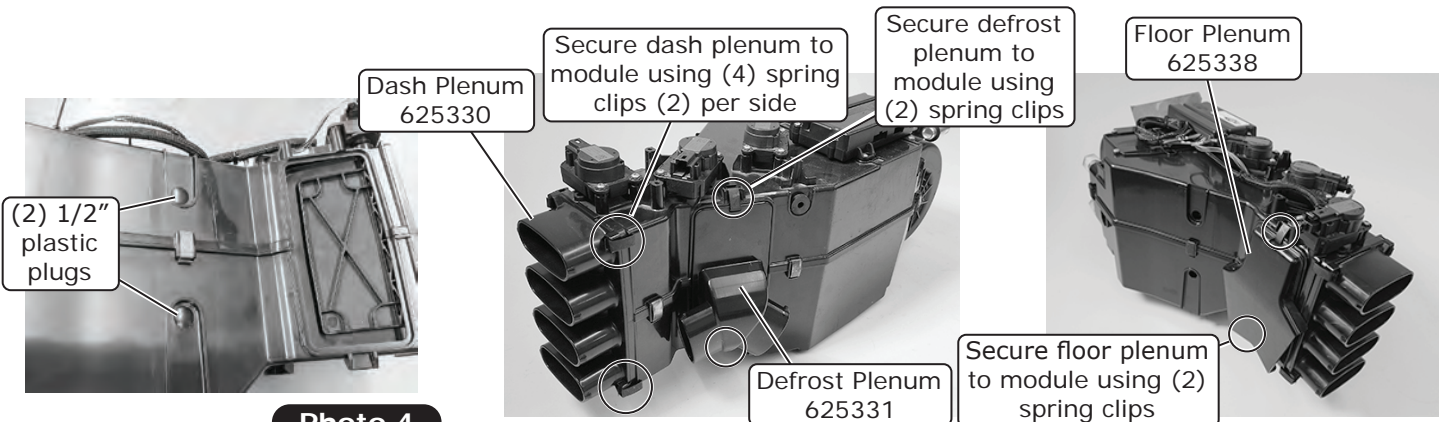

Photo 4

Photo 5

Photo 6

Install evaporator firewall bracket (640720) onto evaporator module

Install (2) 1/4-20 full-threaded studs onto bracket

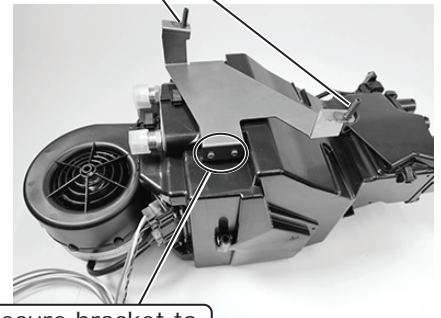
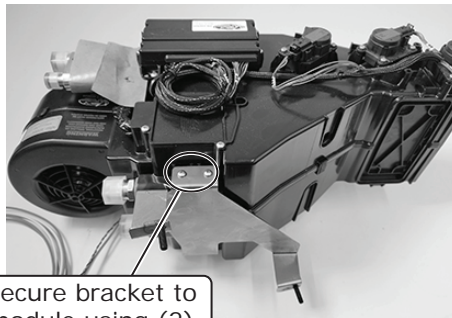
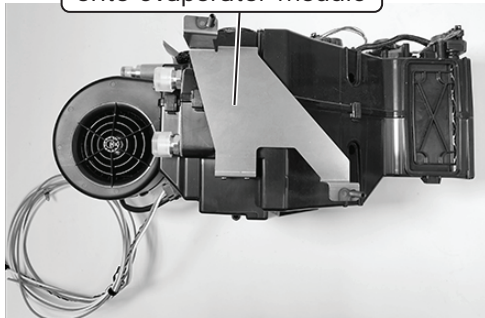

Photo 7

Photo 8

Photo 9

Secure bracket to module using (2) #10 x 5/8" screws

Secure bracket to module using (2) #10 x 5/8" screws

Install upper heater hardline onto top heater core port

Install lower heater hardline onto bottom heater core port

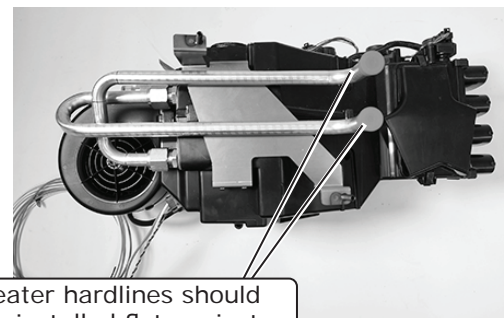
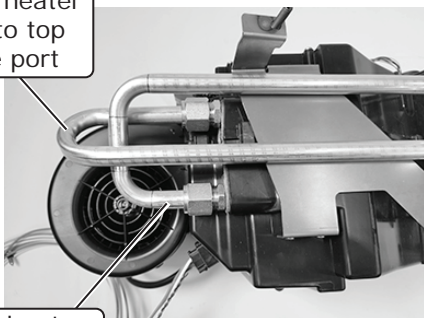

Photo 10

Photo 11

Heater hardlines should be installed flat against evaporator mounting bracket to ensure proper angle of heater hose nipples



www.vintageair.com

Passenger Compartment Wiring

1. Select a suitable location for the relay and ground wire with ring terminal above the kick panel cover and trim.
2. Secure the relay and ring terminal to the steel behind the kick panel using (2) #12 x 1/2" self-tapping screws as shown in Figure 1, below.
3. Route the red and white smaller gauge wires, orange and white larger gauge wires, blue wire, and heater control valve connector through the 5/8" grommet and out through the firewall using the smaller hole in the firewall cover plate (See Photo 1, below).
4. Route the violet power wire to a switched 12v power source on the fuse panel (See Photo 2, below).
NOTE: This requires a male fuse extension (not supplied).
5. Connect the tan wire to the factory dash lights to enable control panel backlighting (if applicable).
6. Connect the BSC wiring to the main harness (See Photo 2, below).
7. Connect the main harness to the ECU (See Photo 3, below).

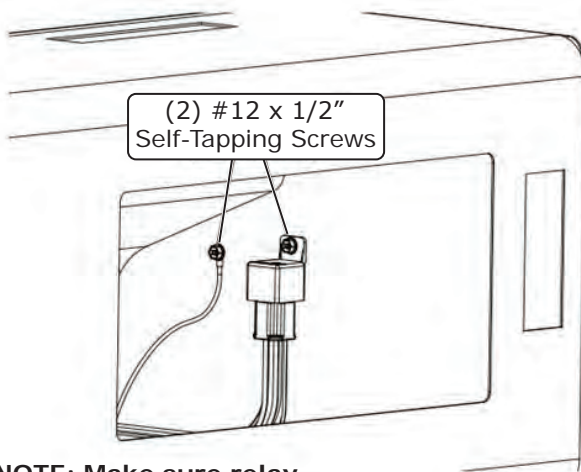

(2) #12 x 1/2"
Self-Tapping Screws

NOTE: Make sure relay mounting does not interfere with glove box door arm.

Figure 1

Route red, and white smaller gauge wires, orange and white larger gauge wires, blue wire, and heater control valve connector through 5/8" grommet

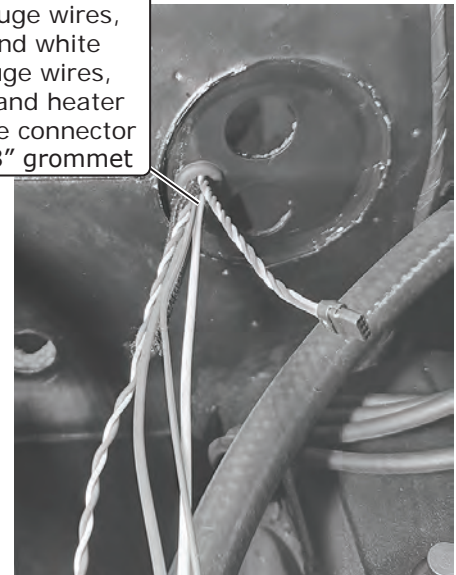
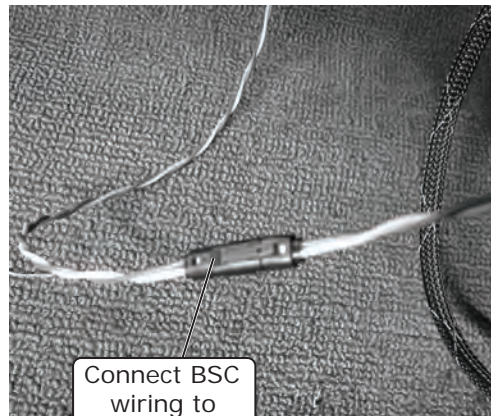

Photo 1

Attach Violet Wire to Switched Power Source

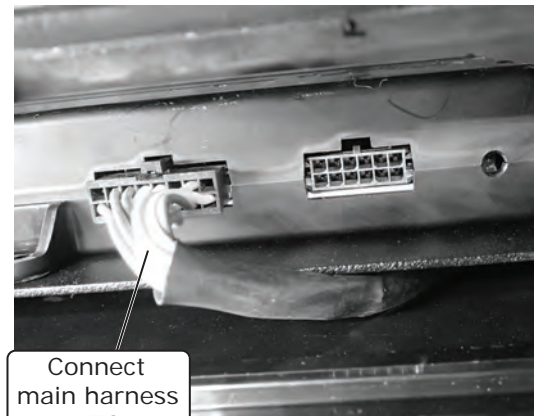

Photo 2



Connect BSC wiring to main harness

Photo 3



Connect main harness to ECU

Photo 4



www.vintageair.com

Evaporator Installation

1. Place the evaporator module onto the passenger floor board (See Photo 1, below).
2. Lift the evaporator module up under the dashboard, insert both heater hardlines into the corresponding holes on the firewall cover and studs on the evaporator bracket into their designated mounting holes on the firewall (See Photos 2 and 3, below).
3. Secure the bracket to the firewall temporarily with nuts, studs will be replaced with bolts (See Photo 4, below).
4. Install the cowl bracket onto the evaporator using (2) 1/4-20 well nuts, and (2) 1/4-20 x 1" serrated flange bolts (See Photo 5, below).
5. Secure the evaporator cowl bracket to the cowl using (2) #14 x 3/4" washer head screws (See Photo 6, below). **NOTE: The evaporator will be pushed at an upward angle to secure the cowl bracket to the cowl.**
6. One by one, remove the studs and replace with (2) 1/4-20 x 3/4" serrated flange hex bolts (See Photos 7 and 8, below).

Place evaporator module onto passenger floor board

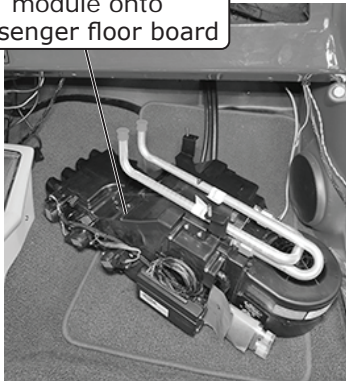

Photo 1

Lift evaporator module up under dashboard

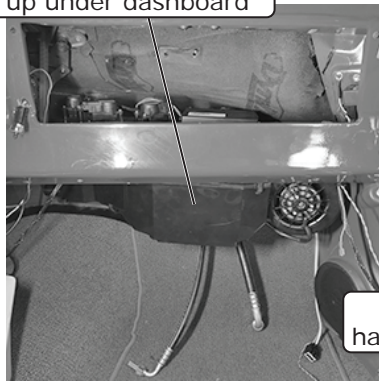
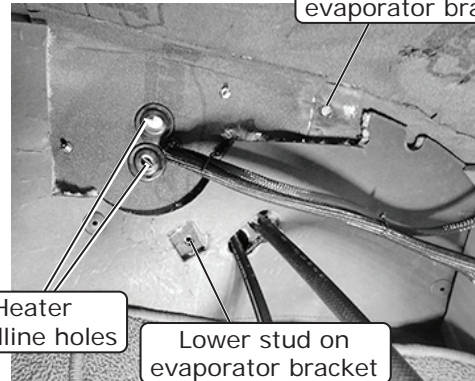

Photo 2

Upper stud on evaporator bracket



Heater hardline holes

Lower stud on evaporator bracket

Photo 3

Secure bracket to firewall temporarily with nuts

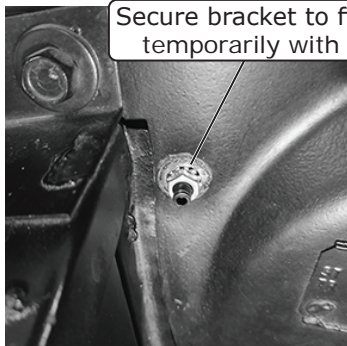

Photo 4

(2) 1/4-20 well nuts and (2) 1/4-20 x 1" serrated flange bolts

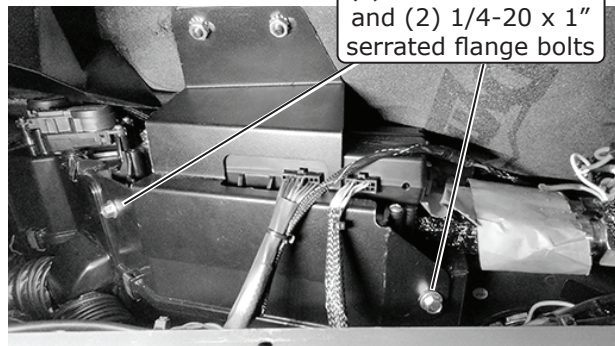

Photo 5

(2) #14 x 3/4" Washer Head Screws



Photo 6

(2) 1/4-20 x 3/4" Serrated Flange Hex Bolts

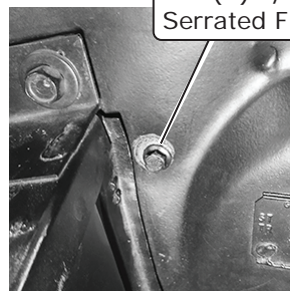

Photo 7

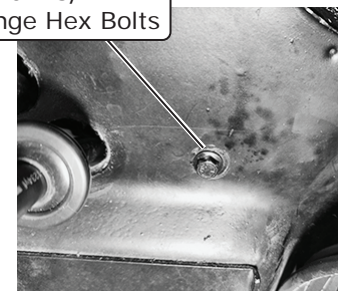

Photo 8



www.vintageair.com

A/C Hose Installation

1. Install a 1 1/4" with 3/8" hole grommet onto the #6 A/C hose over the 90° fitting (See Photo 1, below).
2. Install a large grommet onto the #10 A/C hose over the 90° fitting (See Photo 1, below).
3. Install the hoses with 90° fittings through the firewall as shown in Photo 2, below, then install the grommets into the firewall.
4. From inside the vehicle, route the hoses up towards the fitting on the evaporator module as shown in Figure 1, below.
5. With a properly lubricated O-ring (See Lubricating O-rings & Fitting Torque Specs, Page 11), install the #6 hose onto the module.
6. With a properly lubricated O-ring (See Lubricating O-rings & Fitting Torque Specs, Page 11), install the #10 hose onto the module.
7. Refer to A/C & Heater Hose Routing, Page 16, for routing.

Install a 1 1/4" with 3/8" hole grommet onto #6 A/C hose over 90° fitting

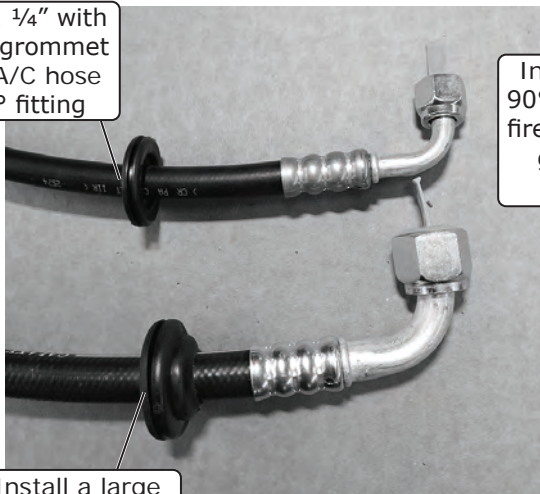

Install a large grommet onto #10 A/C hose over 90° fitting

Photo 1

Install hoses with 90° fittings through firewall, then install grommets into firewall



Photo 2

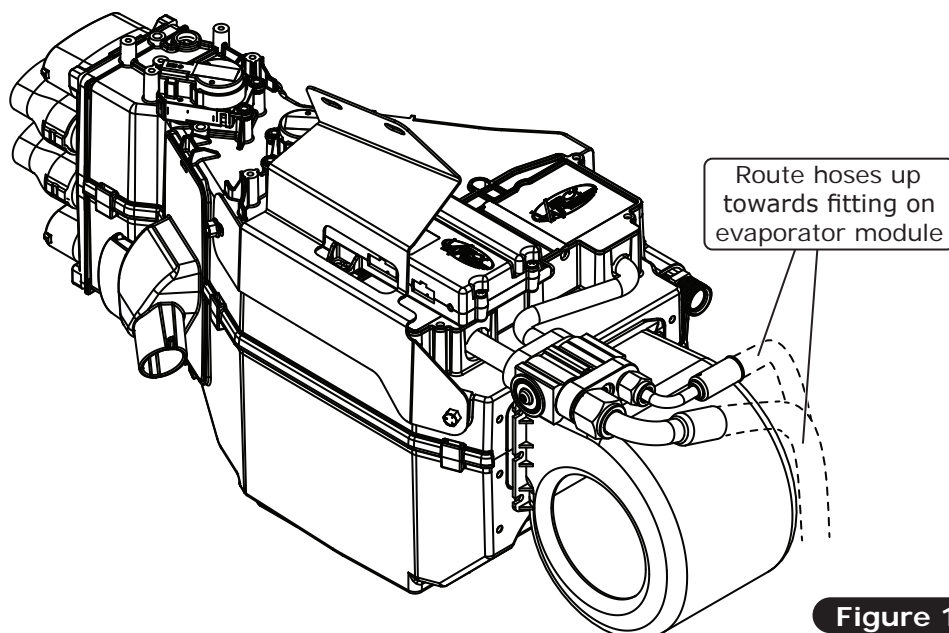

Figure 1



www.vintageair.com

Heater Hose & Heater Control Valve Installation

1. Route a piece of heater hose from the water pump to the heater line coming through the firewall as shown in Figure 1, below. Secure using hose clamps.
2. Route a piece of heater hose from the intake to the heater line coming through the firewall as shown in Figure 1, below. **NOTE: Install the heater control valve in line with the intake manifold (pressure side) heater hose, secure using hose clamps as shown. Note proper flow direction.**
3. Hose should protrude through the firewall cover slightly to close the gap between the aluminum line and the firewall cover. **NOTE: Grommets pre-installed with firewall cover.**

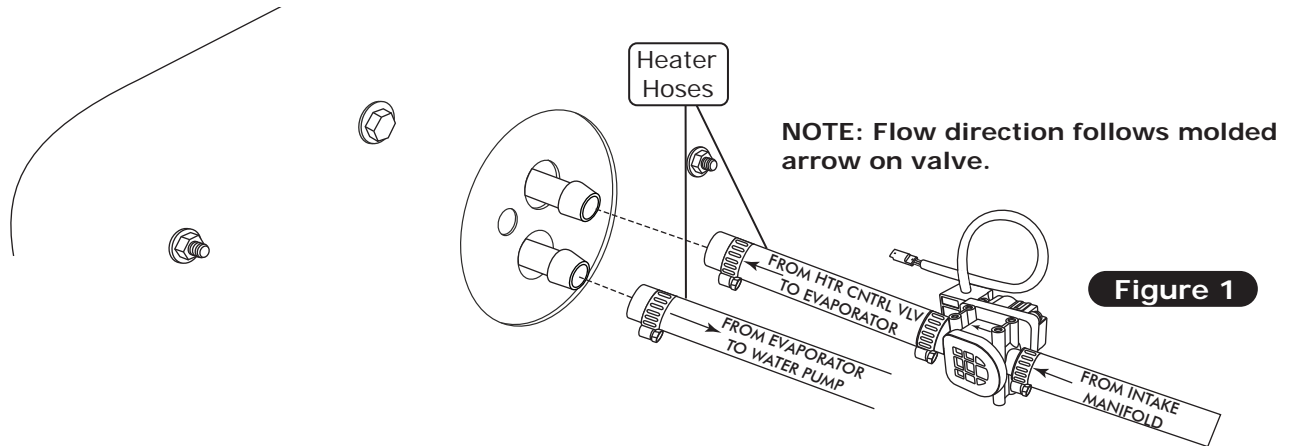

A/C and Heater Hose Routing

NOTE: Vintage Air Systems use 5/8" heater connections. On engines equipped with 3/4" hose nipples, these will need to be removed and replaced with 5/8" nipples (not supplied). For water pumps with a cast-in 3/4" heater outlet, a 3/4" x 5/8" reducer fitting in the heater hose (not supplied) or molded hose (Vintage Air Part # 099010) will need to be installed.

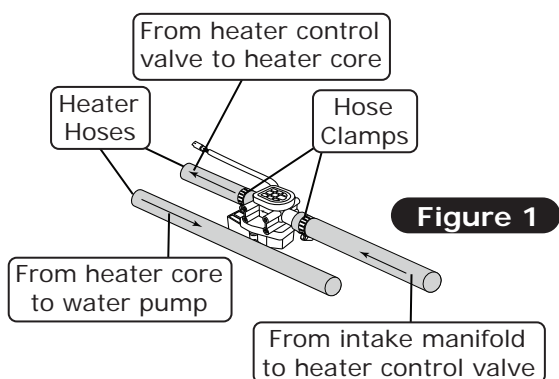

NOTE: Flow direction follows molded arrow on valve.

#6 A/C Hose Evaporator/Drier

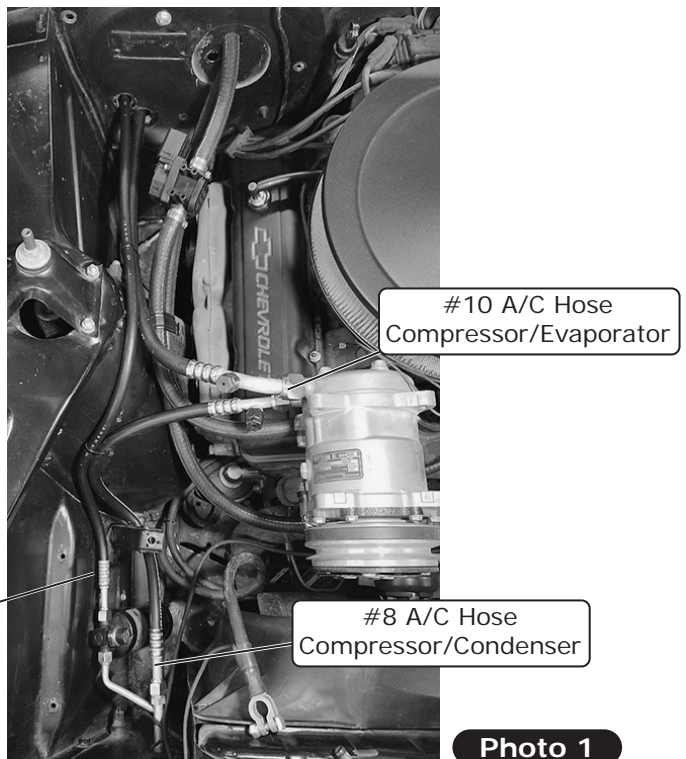



www.vintageair.com

Drain Hose Installation

1. Locate the evaporator drain on the bottom of the evaporator case.
2. In line with the drain, lightly make a mark on the firewall. Measure 1" down and drill a 5/8" hole through the firewall (See Figure 1, below).
3. Install the drain hose onto the bottom of the evaporator module, and route it through the firewall. Install the 1/2" 90° drain elbow on the drain hose as shown in Figure 1, below).

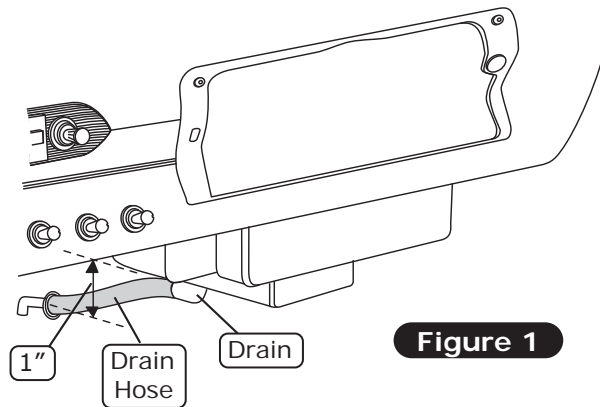

Control Panel Installation

1. Refer to control panel instructions included with this kit.



www.vintageair.com

Engine Compartment Wiring

NOTE: The following connections are critical to the performance of the system. Before making connections, refer to the **Quality Crimp Guidelines, Page 24**.

1. Route power and ground wires toward the battery (See Photo 1, below).
2. Install the supplied heat shrink over the 12 AWG orange standard fuse holder assembly wire and crimp it to the 12 AWG orange wire from the main wiring harness (See Photo 2, below). Slide the heat shrink over the crimp, then apply heat.
3. Install the supplied heat shrink over the 16 AWG black mini fuse holder assembly wire and crimp it to the 16 AWG red wire from the main wiring harness (See Photo 3, below). Slide the heat shrink over the crimp, then apply heat.
4. Install the fuses into the holders (See Photos 4 and 5, below).
5. Install the supplied heat shrink over the white ground wires, then crimp on the supplied ring terminals (See Photo 6, below). Slide the heat shrink over the crimps, then apply heat. **NOTE: Both white wires can be crimped to the larger ring terminal. Install the heat shrink, then strip the wires, twist them together and trim to length. Crimp on the ring terminal, then slide the heat shrink over and apply heat** (See Photos 7 and 8, below).

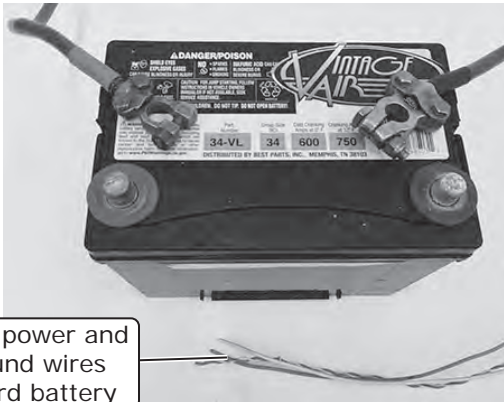

Route power and ground wires toward battery

Photo 1

Crimp 12 AWG orange fuse holder wire to 12 AWG orange wire from main wiring harness



Photo 2

Install heat shrink over 12 AWG orange standard fuse holder assembly wire

Crimp 16 AWG black fuse holder wire to 16 AWG red wire from main wiring harness



Photo 3

Install heat shrink over 16 AWG black standard fuse holder assembly wire

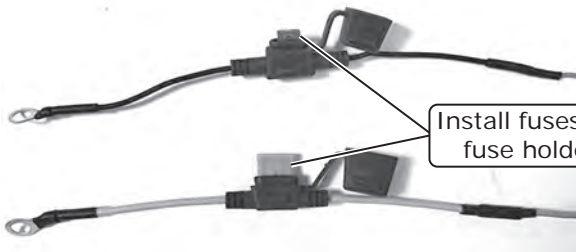

Install fuses into fuse holders

Photo 4



Photo 5

Both white ground wires can be crimped together. Install heat shrink, then strip wires, twist together and trim to length.

Install heat shrink over white ground wires, then crimp on ring terminals

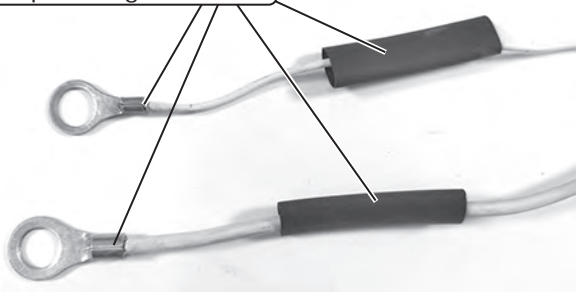

Photo 6



Photo 7

Crimp on ring terminal, then slide heat shrink over and apply heat

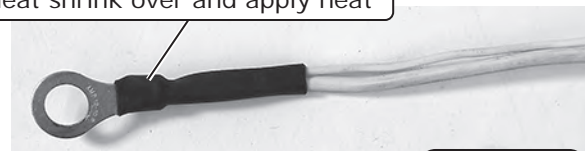

Photo 8



www.vintageair.com

Engine Compartment Wiring (Cont.)

6. Connect the ground wire ring terminals to the negative battery terminal connector (See Photos 9 and 10, below).
7. Connect the positive wire ring terminals to the positive battery terminal connector (See Photos 11 and 12, below). **NOTE: Do not connect power until the installation is completed.**
8. Wiring completed (See Photo 13, below).

Connect ground wire ring terminals to negative battery terminal
NOTE: Either connection application can be used.

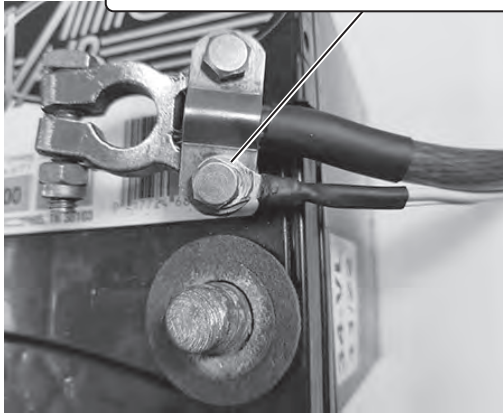

Photo 9

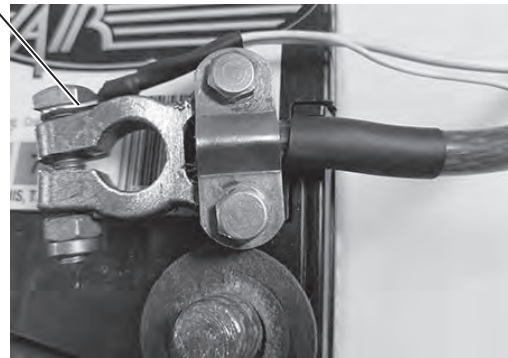

Photo 10

Connect power wire ring terminals to positive battery terminal
NOTE: Either connection application can be used.

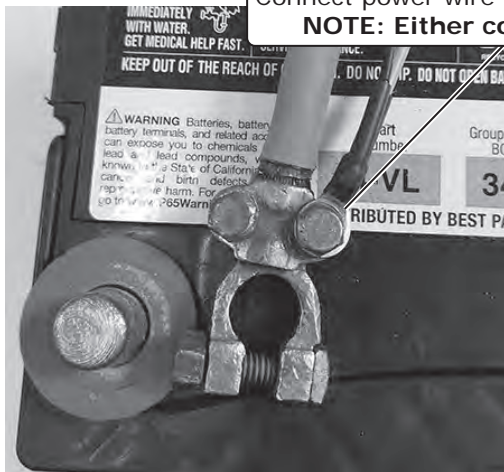
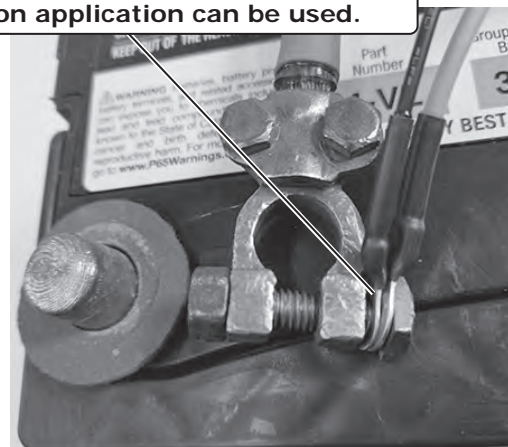

Photo 11



NOTE: Do not connect power until installation is completed.

Photo 12



Completed Installation Shown

Photo 13



www.vintageair.com

Under Dash Louver Installation

1. Place the driver-side louver housing under the dash, align 1" from the front edge of the dash and mark mounting holes (See Figure 1, below). Drill 7/64" mounting holes in bottom of the dash (See Figure 1, below).
2. Place the center/passenger-side louver bezel under the dash, and align 1" from the front edge of the dash and mark mounting holes. Drill 7/64" mounting holes in bottom of the dash as shown in Figure 1, below.
3. Using (2) #8 x 1/2" pan head screws, install the driver-side louver housing under the dash as shown in Figure 1, below.
4. Install 1/2" plastic plug into center hole. Using (3) #8 x 1/2" pan head screws, install the center/passenger-side louver bezel under the dash as shown in Figure 1, below.
5. Install the louvers in the driver-side housing and center/passenger-side louver bezel as shown in Figure 1a, below.
6. Once the louver assembly is in place, route the duct hoses and attach them to the correct location on the evaporator as shown in Duct Hose Routing, Page 23.

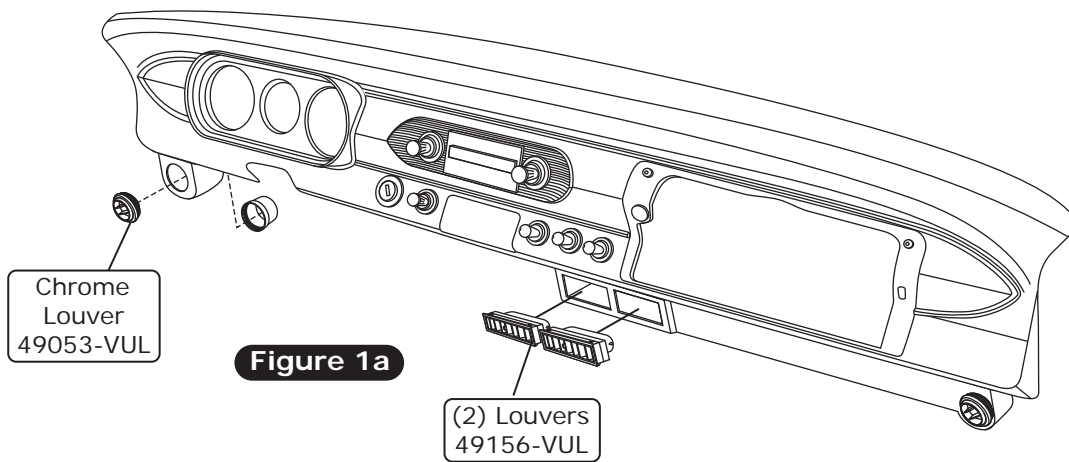
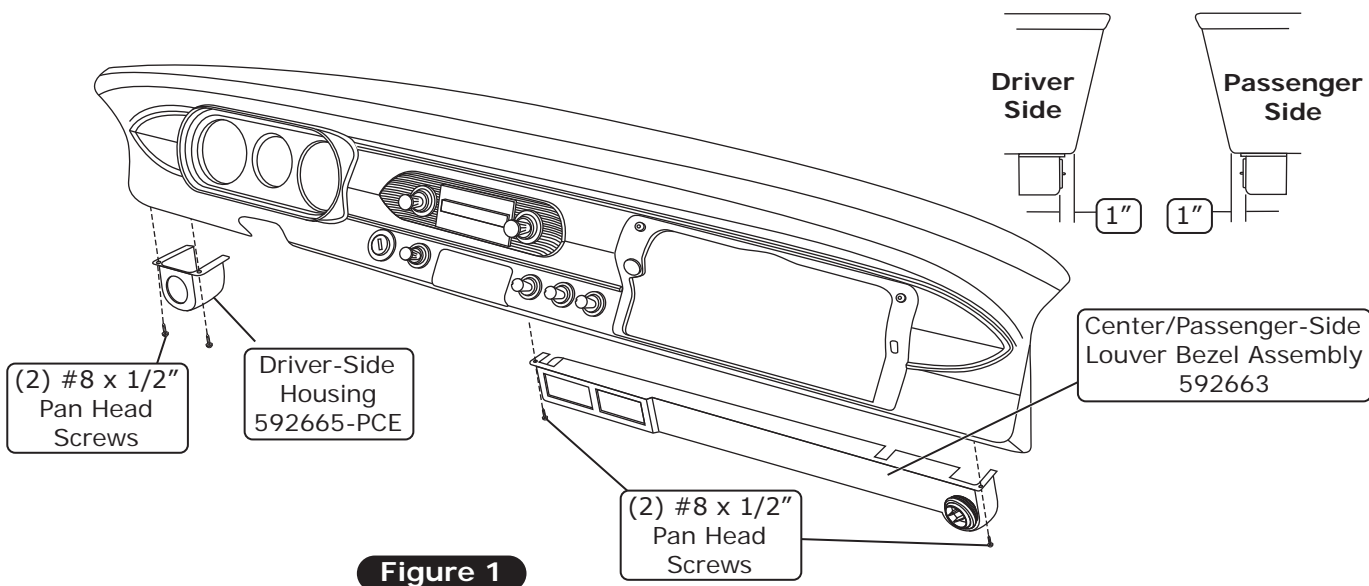



www.vintageair.com

Final Steps: Installation Check

Installation Check	
ITEM TO CHECK	Procedure
<input type="checkbox"/>	<p>ECU</p> <p>If no blinking is observed after 1 minute of turning the ignition on, go to the next check.</p> <p>If repetitive blinking is observed, go to the Advanced Diagnostics Section to diagnose.</p>
<input type="checkbox"/>	<p>Blower speed control</p> <p>Set the blower speed control to OFF, <u>confirm that the blower is off</u>.</p> <p>Position the blower speed control to LOW then MEDIUM and then HIGH. <u>At each setting confirm that the blower speed increases</u>, do this by feeling for the amount of air coming from the unit and hearing the blower speed increase.</p>
<input type="checkbox"/>	<p>Mode control</p> <p>Set the MODE control to the DASH position. <u>Confirm that air is being blown at the dash vents</u>.</p> <p>Set the MODE control to the FLOOR position. <u>Confirm that air is being blown at the floor vents</u>.</p> <p>Set the MODE control to the DEFROST position. <u>Confirm that all air is being blown from the defrost vents</u></p> <p>If heater lines are installed:</p> <p>Set the MODE control to the DASH position. Set the TEMP control to the MAX HEAT position. <u>Confirm that HOT air is coming from the dash vents</u>.</p>
<input type="checkbox"/>	<p>Temperature control</p> <p>If system is charged:</p> <p>Set the TEMP control to the MAX COOL position. <u>Confirm that COLD air is coming from the dash vents</u>.</p> <p>Also <u>confirm that the compressor "clicks" on</u> when adjusting the TEMP control from the MAX HEAT position to the MAX COOL position.</p>
<input type="checkbox"/>	<p>AC Indicator (If applicable)</p> <p>While the MODE control is set to the DASH position, and the TEMP control is set to the MAX COOL/MIN HEAT position, <u>confirm that the blue AC Indicator light is on</u>.</p>
<input type="checkbox"/>	<p>Backlight (If applicable)</p> <p>If your control panel has backlight capabilities and has been wired, turn the dash lamp on and <u>confirm that the AC panel's legend is lit</u>.</p>
<input type="checkbox"/>	<p>Fittings</p> <p>Verify AC and Heater fittings are all tight.</p>



www.vintageair.com

Final Steps: Completing the Install

1. Reinstall all previously removed items.
2. Install the new glove box and glove box door using OEM screws (See Figure 1, below).
3. Fill radiator with at least a 50/50 mixture of approved antifreeze and distilled water. It is the owner's responsibility to keep the freeze protection at the proper level for the climate in which the vehicle is operated. Failure to follow antifreeze recommendations will cause heater core to corrode prematurely and possibly burst in A/C mode and/or freezing weather, voiding your warranty.
4. Double check all fittings, brackets and belts for tightness.
5. Vintage Air recommends that all A/C systems be serviced by a licensed automotive A/C technician.
6. Evacuate the system for a minimum of 45 minutes prior to charging, and perform a leak check prior to servicing.
7. Charge the system to the capacities stated on Page 4 of this instruction manual.
8. See Operation of Controls procedures on Page 27.

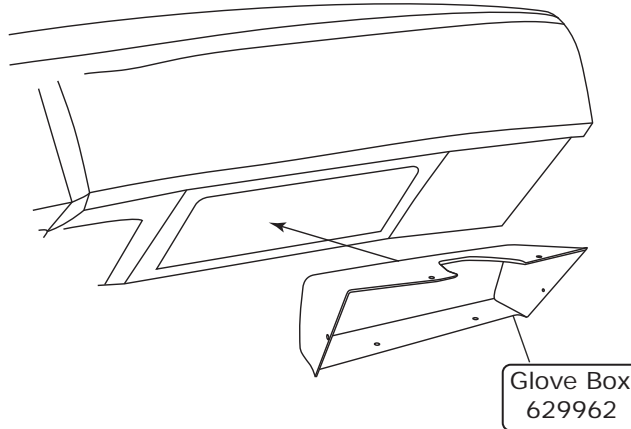



www.vintageair.com

Duct Hose Routing

NOTE: For the system to function optimally, the duct hoses must be routed as directly as possible, taking care to avoid kinks, sharp bends and unnecessary length. Vintage Air supplies duct hoses in continuous lengths that will need to be cut to size depending on application. Before cutting, familiarize yourself with the installation instructions and verify the routing will work with your application. For custom hose routing, additional hose may be needed and can be purchased from Vintage Air.

1. Stretch the duct hose until there is no slack, measure, mark and cut hose to size (See Photo 1, below).

Stretch, measure, mark and cut hose to size



Photo 1

Disclaimer: Before cutting duct hose to length, verify the routing will work for your application.

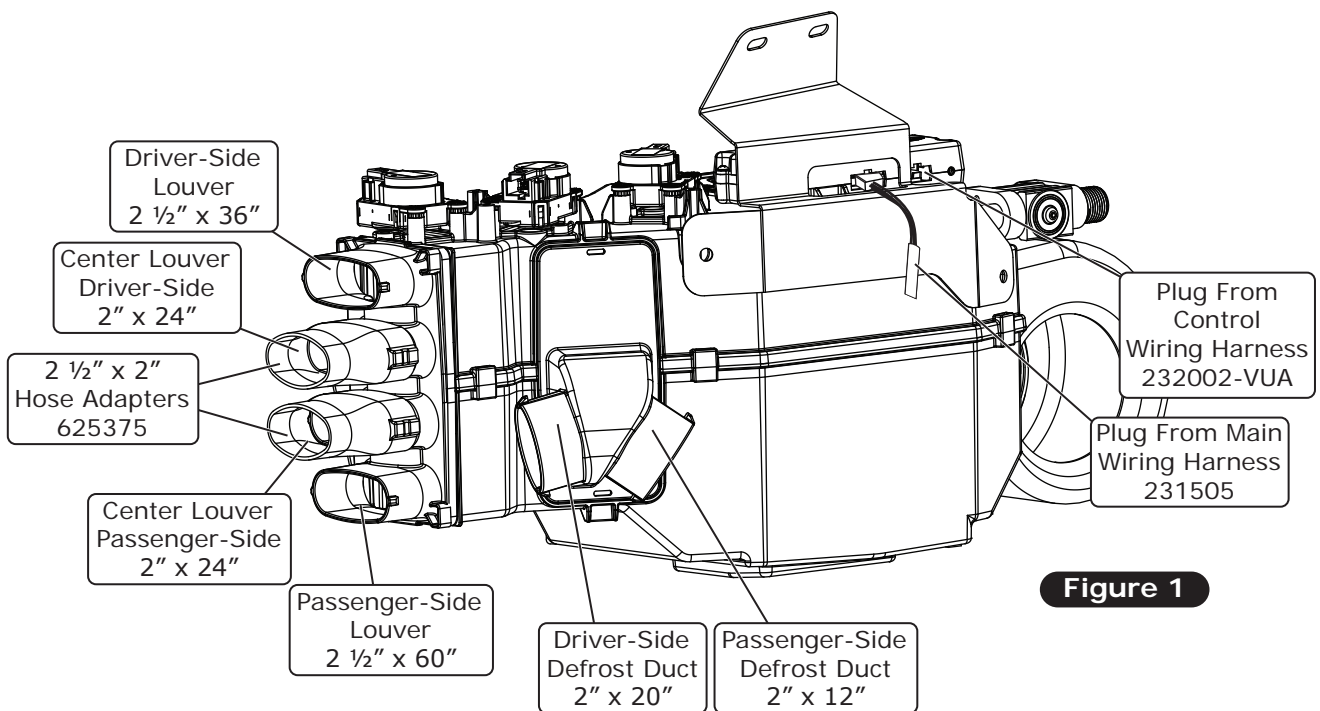

Figure 1



NOTE: ECU must be placed away from water and humidity, and also be accessible for servicing. If relocating, connectors must be positioned towards the bottom.

Position connectors towards bottom



www.vintageair.com

Quality Crimp Guideline

Acceptable strip length
(Some copper visible)

Crimped area is centered
on each side of splice

Bad strip length
(Too much copper visible)
Visible copper should be
just enough to ensure
clearance between splice
area and wire insulation

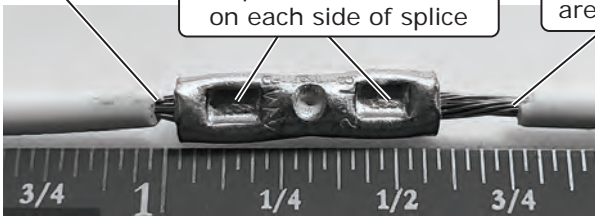

Photo 1

A good crimp requires
seam of butt splice to be
opposite of crimp die tooth

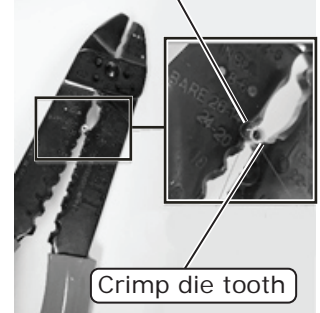

Photo 2

Good Ring Terminal Crimp Bad Ring Terminal Crimp

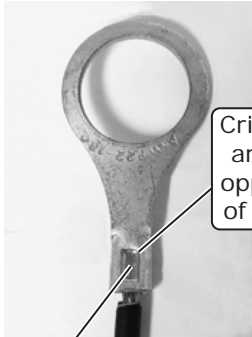

Photo 3

Crimp
area is
centered
on barrel

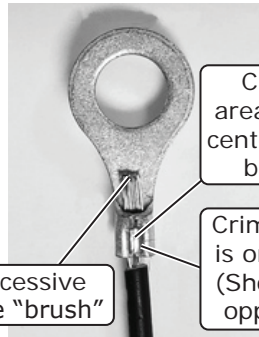

Photo 4

Excessive
wire "brush"

Crimp
area is not
centered on
barrel

Crimp area
is on seam
(Should be
opposite)



Photo 5

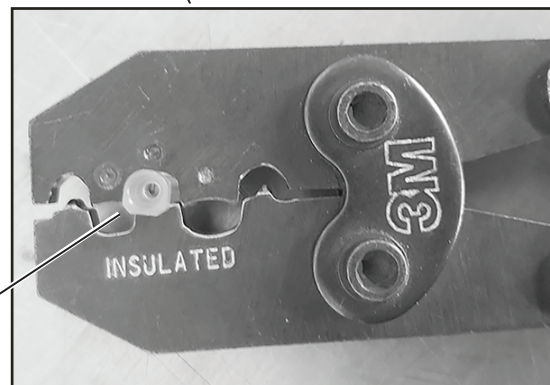

Photo 5a

Use a ratcheting crimp tool
for insulated barrel terminals
when crimping the provided
female insulated terminal.
Ensure terminal is inserted in
appropriate position before
crimping.



www.vintageair.com

Gen 5 Wiring Diagram

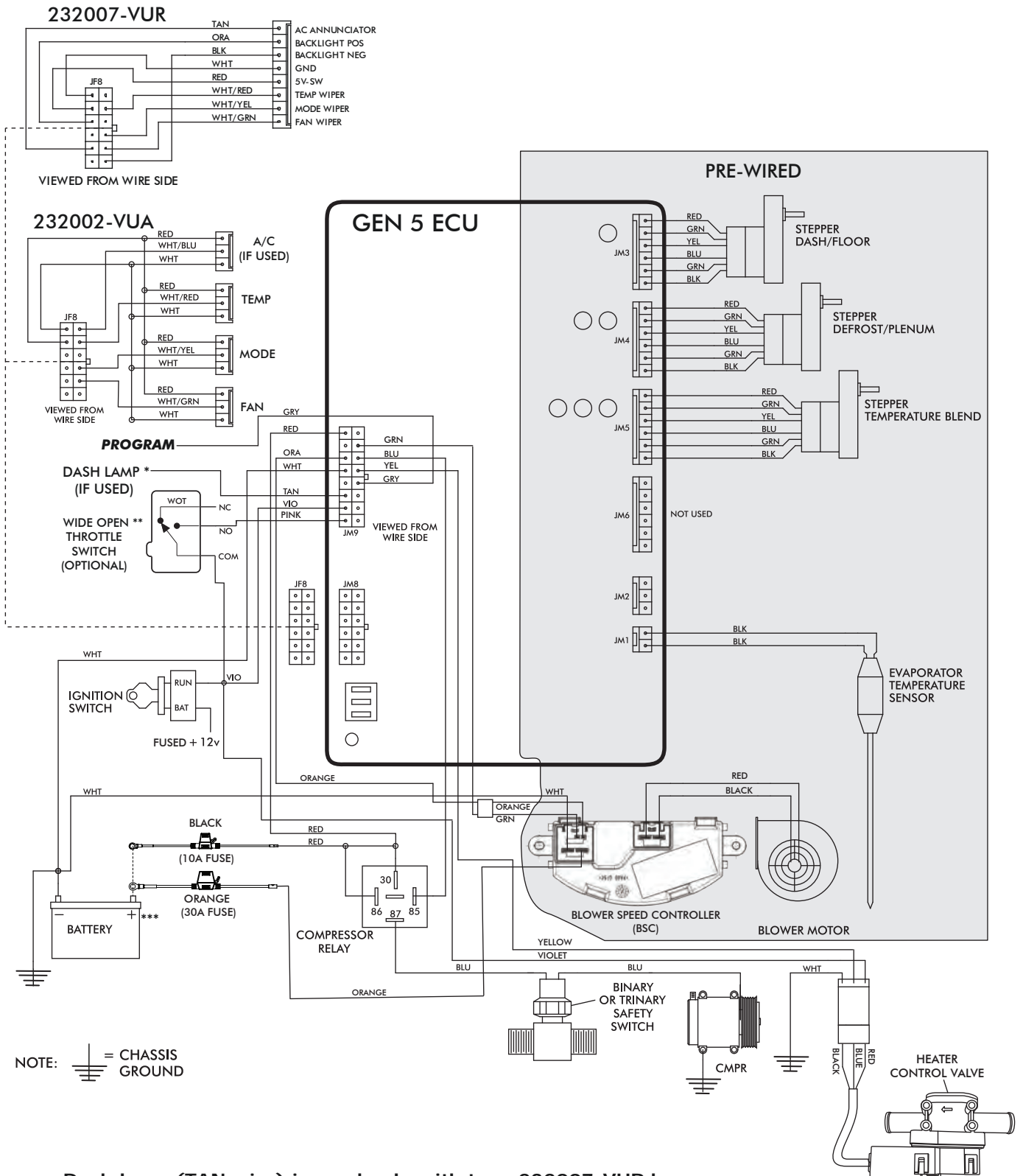

- * Dash lamp (TAN wire) is used only with type 232007-VUR harness.
- ** Wide open throttle switch contacts close only at full throttle, which disables A/C compressor.
- *** Install fuse assemblies at or as near to the battery as possible.



www.vintageair.com

Gen 5 Wiring Instructions

WIRING HARNESS (231505) ↓

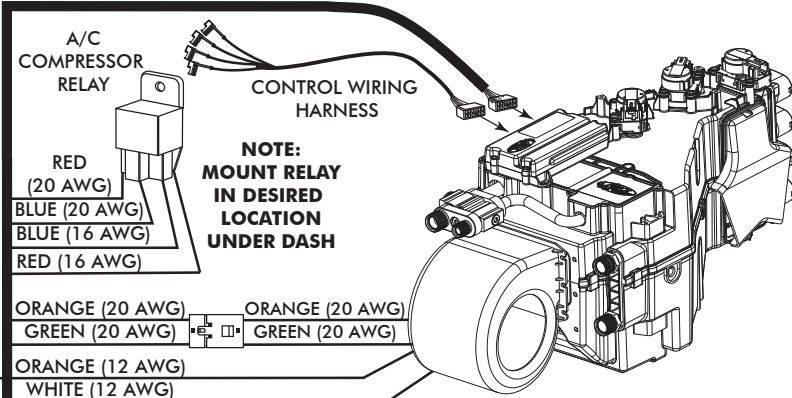

Ignition Switch:
Using provided butt splice (PN 226004), connect the 20 AWG violet wire to a 5A fused and switched 12V source such as Key On.

Wide Open Throttle Switch (Optional):
If a wide open throttle switch is required, connect the 20 AWG pink wire to a normally open switch that, when closed, connects a fused and switched 12V source to the pink wire. See Gen 5 wiring diagram for an example.

Dash Light (Optional):
If using a Vintage Air control panel with back light, connect the 20 AWG tan wire to the vehicle's dash back light 0-12V using provided butt splice (PN 226004).

WIRING HARNESS (232020) →

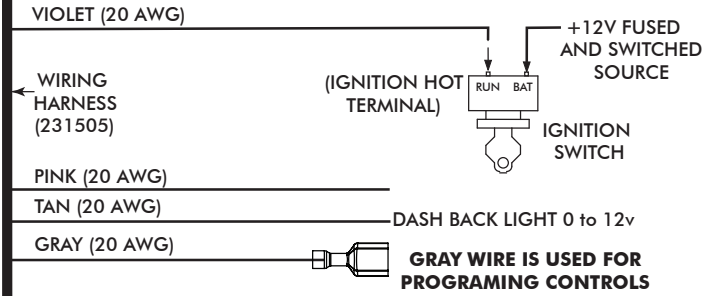

FIREWALL

WIRING HARNESS (232020) →

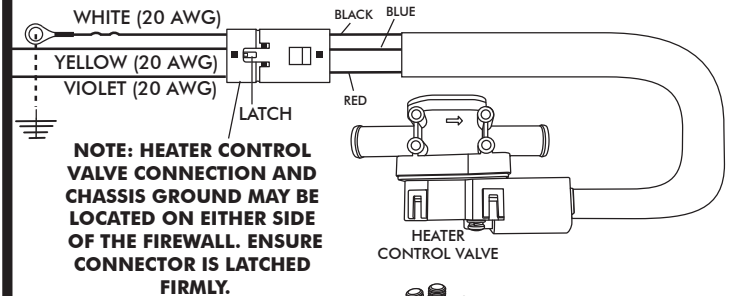

Heater Control Valve:
Connect the Violet/Yellow/White twisted branch with 3 position connector into the heater control valve connector. Ensure that the mating latch is fully seated.

Binary/Trinary & Compressor:
Binary Switch: Terminate provided insulated female terminal (PN 23172-VUW) to the blue 16 AWG wire. Connect as shown.
Trinary Switch: Connect according to trinary switch wiring diagram.

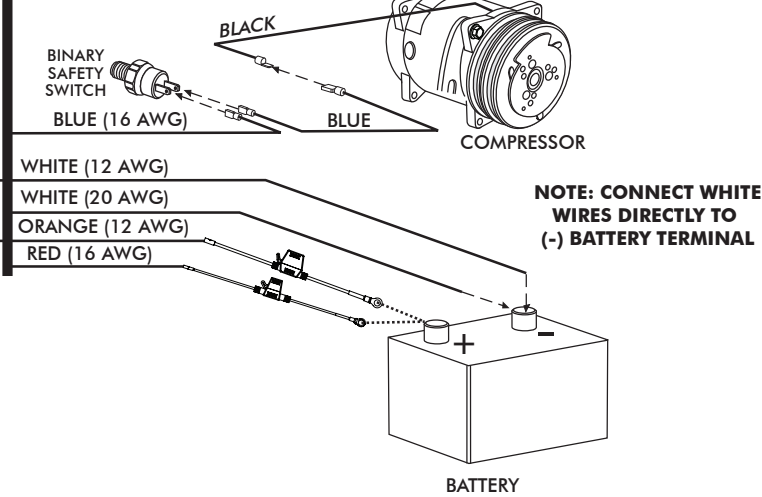

Battery Connections:
ECU Ground: Terminate provided ring terminal (PN 226110) to 20 AWG white wire from the 231505 wire assembly and install at battery.
ECU PWR: Terminate provided fuse assembly with black leads (PN 233012) to the 16 AWG red wire from the 231505 wire assembly. Install provided 10A Red Mini Fuse (PN 226118). Install at battery.
Blower Speed Controller (BSC) Ground: Terminate provided ring terminal (PN 226111) to 12 AWG white wire from the 232020 wire assembly and install at battery.
Blower Speed Controller (BSC) PWR: Terminate provided fuse assembly with orange leads (PN 233008) to the 12 AWG orange wire from the 232020 wire assembly. Install provided 30A Green ATO/ATC Fuse (PN 226125). Install at battery.



www.vintageair.com

Operation of Controls

On Gen IV or Gen 5 systems with three lever/knob controls, the temperature control toggles between heat and A/C operations. To activate A/C, move the temperature lever/knob all the way to cold and then back it off to the desired vent temperature. For heat operation, move the temperature lever/knob all the way to hot and then adjust to the desired vent temperature. The blower will momentarily change speed, each time you toggle in and out of heat and A/C operations, to indicate the change. **NOTE: For proper control panel function, refer to control panel instructions for calibration procedure.**

Blower Speed

This lever/knob controls blower speed, from OFF to HI.

Mode Control

This lever/knob controls the mode positions, from DASH to FLOOR to DEFROST, with a blend in between.

Temperature Control

This lever/knob controls the temperature, from HOT to COLD.

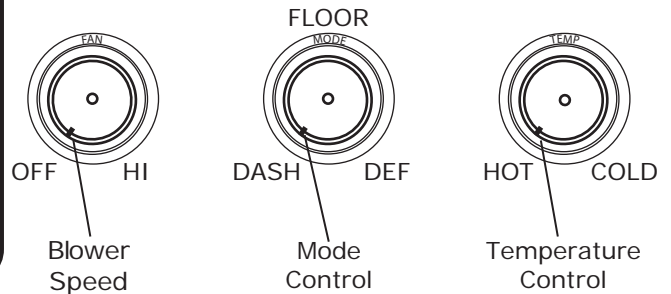

A/C Operation

Blower Speed

Adjust to desired speed.

Mode Control

Adjust to desired mode position (DASH position recommended).

Temperature Control

For A/C operation, adjust to coldest position to engage compressor (Adjust between HOT and COLD to reach desired temperature).

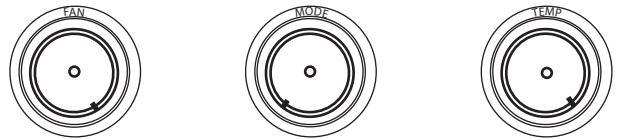

Heat Operation

Blower Speed

Adjust to desired speed.

Mode Control

Adjust to desired mode position (FLOOR position recommended).

Temperature Control

For maximum heating, adjust to hottest position (Adjust between HOT and COLD to reach desired temperature).

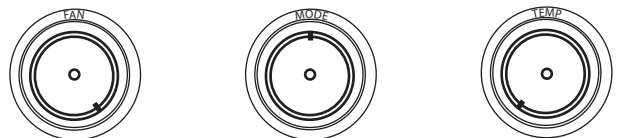

Defrost/De-fog Operation

Blower Speed

Adjust to desired speed.

Temperature Control

Adjust to desired temperature.

Mode Control

Adjust to DEFROST position for maximum defrost, or between FLOOR and DEFROST positions for a bi-level blend (Compressor is automatically engaged).

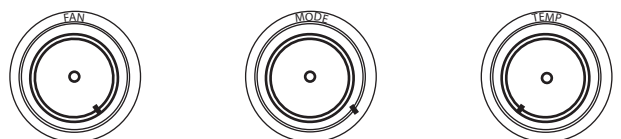



www.vintageair.com

Troubleshooting Guide

This printed troubleshooting guide is our basic guide that covers common installation problems. To see our advanced diagnostics and troubleshooting guide, please refer to the following page for instructions on how to download the complete guide.

WARNING: While troubleshooting the system, never probe connector terminals from the front mating side, only back probe.

WARNING: While troubleshooting the system, never use automotive check lights.

Symptom	Condition	Checks	Actions	Notes
1. Blower stays on high speed with ignition on.	No other functions work.	Check for damaged pins or wires in the control panel wire assembly and mating header at ECU.	If found damaged, replace wire assembly or ECU.	If fuse continues to blow, there is a serious problem in the wiring. Check all wiring and ensure the wire is not damaged and shorting out along its route.
	All other functions work.	Check for a bad ECU GND. Check for damaged pins or wires in the control panel wire assembly and mating header at ECU. Check if Blower power fuse is blown. Check for a bad ECU GND.	If found damaged, replace wire assembly or ECU. Replace fuse. Repair connection.	
2. Compressor will not turn on (All other functions work).	System is not charged.	System must be charged for compressor to engage.	Charge system.	Danger: Never bypass safety switch with engine running. Serious injury can result.
	System is charged.	Check for faulty A/C potentiometer or associated wiring (not applicable to 3-pot controls).	Check continuity to ground on white control head wire. Check for 5V on red control head wire.	To check for proper pot function, check voltage at white/red wire. Voltage should be between 0V and 5V, and will vary with pot lever position.
		Check for disconnected or faulty thermistor.	Check 2-pin connector at ECU housing.	Disconnected or faulty thermistor will cause compressor to be disabled.
3. Compressor will not turn off (All other functions work).	Compressor will not turn off (All other functions work).	Check for faulty A/C potentiometer or associated wiring.	Repair or replace pot/control wiring.	Red wire at A/C pot should have approximately 5V with ignition on. White wire will have continuity to chassis ground. White/Red wire should vary between 0V and 5V when lever is moved up or down.
		Check for faulty A/C relay.	Replace relay.	



www.vintageair.com

Troubleshooting Guide (Cont.)

Symptom	Condition	Checks	Actions	Notes
4. System will not turn on, or runs intermittently.	Works when engine is not running; shuts off when engine is started	Noise interference from either ignition or alternator.	Install capacitors on ignition coil and alternator. Ensure good ground at all points. Relocate coil and associated wiring away from ECU and ECU wiring. Check for burned or loose plug wires.	Ignition noise (radiated or conducted) will cause the system to shut down due to high voltage spikes. If this is suspected, check with a quality oscilloscope. Spikes greater than 16V will shut down the ECU. Install a radio capacitor at the positive post of the ignition coil (see radio capacitor installation bulletin). A faulty alternator or worn out battery can also result in this condition.
	Will not turn on under any conditions.	Verify connections on power lead, ignition lead, and both white ground wires. Verify battery voltage is greater than 10 volts and less than 16 while engine is running.	Check for power at ECU, and confirm ignition is being applied to ECU properly. Verify proper meter function by checking the condition of a known good battery.	
5. Loss of mode door function.	No mode change at all.	Check for damaged mode switch or potentiometer and associated wiring.		
	Blower turns on and off rapidly.	Battery voltage is at least 12V. Battery voltage is less than 12V.	Ensure all system grounds and power connections are clean and tight. Charge battery.	System shuts off blower at 10V. Poor connections or weak battery can cause shutdown at up to 11V.
7. Erratic functions of blower, mode, temp, etc.		Check for damaged switch or pot and associated wiring.	Repair or replace.	

Advanced Diagnostics and Troubleshooting Guide

If after referencing the Troubleshooting Guide, the issue is not resolved, move to The Advanced Diagnostics and Troubleshooting Guide that covers the following:

- ECU Diagnostics Codes
- 1. ECU Blink Sequence
- 2. Firmware Version Number
- 3. ECU Model Number
- 4. ECU Start-Up Blink Sequence
- 5. Diagnostic Codes
- Complete Advanced Troubleshooting Guidelines

Access the latest version of the Advanced Diagnostics and Troubleshooting Guide by scanning the following QR code on your mobile device:



You can also access the guide by typing the following address into your web browser:

https://www.vintageair.com/instructions_pdf/905000.pdf



www.vintageair.com

Packing List: Evaporator Kit (561296)

No.	Qty.	Part No.	Description
1.	1	765100	Gen 5 Magnum Max Module with 404 ECU
2.	1	781296	Accessory Kit

Checked By: _____
Packed By: _____
Date: _____

1



Gen 5 Magnum Max
Module with 404 ECU
765100

2

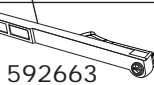
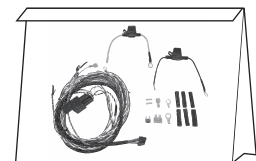
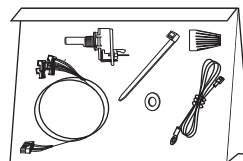
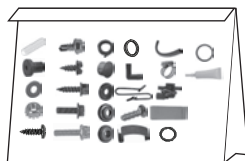
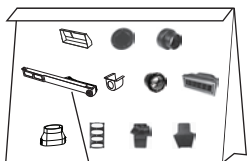
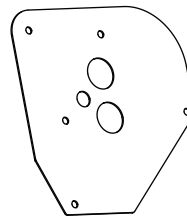
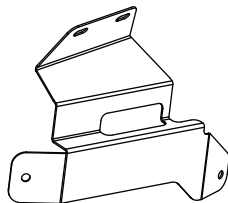
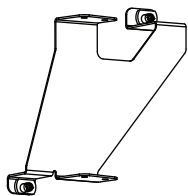

592663

Accessory Kit
781296

**NOTE: Images may not depict actual parts and quantities.
Refer to packing list for actual parts and quantities.**