

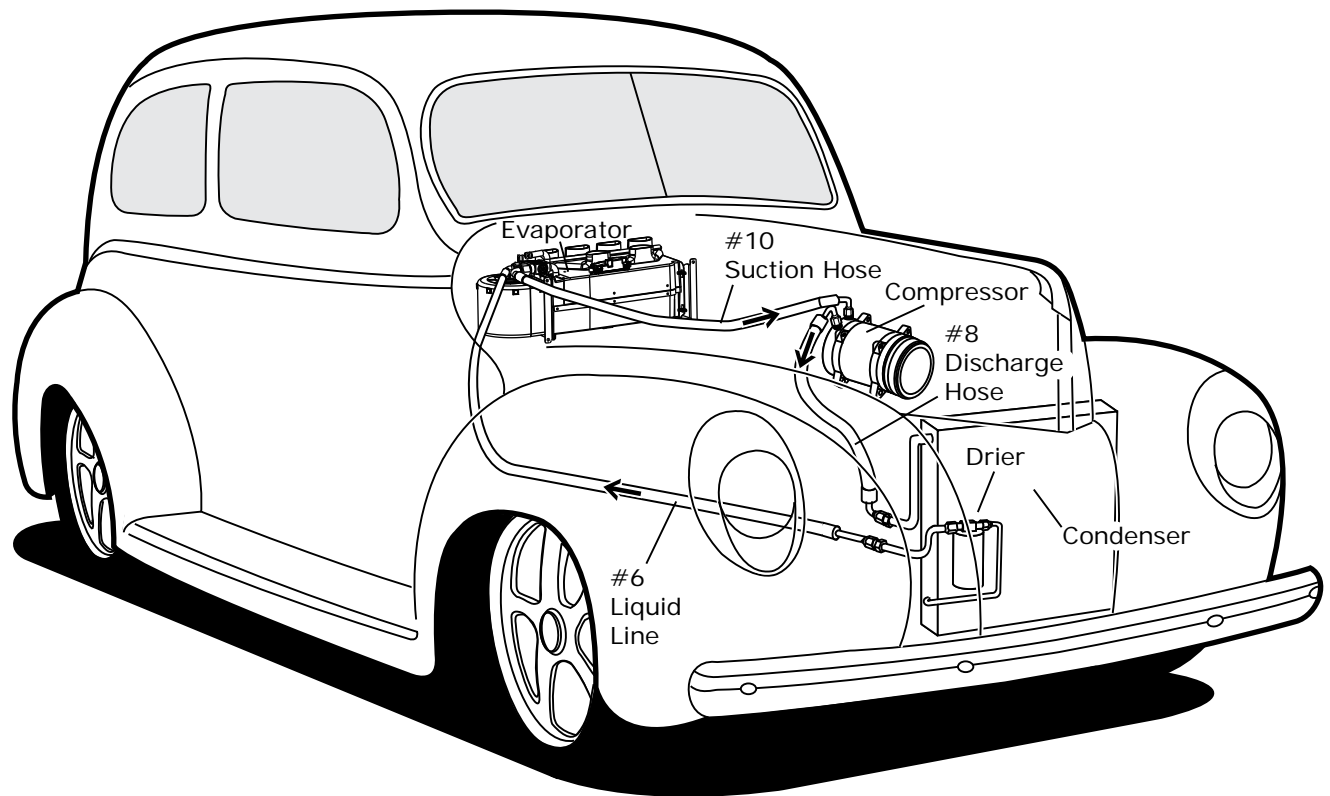

# Super Gen 5 Evaporator Kit (681000)



18865 Goll St. San Antonio, TX 78266  
Phone: 800-862-6658  
Sales: [sales@vintageair.com](mailto:sales@vintageair.com)  
Tech Support: [tech@vintageair.com](mailto:tech@vintageair.com)  
[www.vintageair.com](http://www.vintageair.com)



www.vintageair.com

# Table of Contents

Cover..... 1

Table of Contents..... 2

Packing List/Parts Disclaimer..... 3

Information Page.....4

Wiring Notice..... 5

Additional Parts and Components for Universal Installations..... 6

Evaporator Dimensions..... 7

Planning Overview..... 8

Planning Overview (Cont.), Condenser Assembly & Installation, Compressor and Brackets..... 9

Installation Steps..... 10

Installation Steps (Cont.)..... 11

Installation Steps (Final)..... 12

Drain Hose Installation..... 13

Hose Routing Diagram..... 14

Duct Hose Routing and ECU Relocation, Lubricating O-rings, Properly Seated O-ring Land..... 15

Heater Hose Installation/Final Steps..... 16

Engine Compartment Wiring..... 17

Engine Compartment Wiring (Cont.)..... 18

Final Steps: Installation Check..... 19

Quality Crimp Guideline..... 20

Gen 5 Super Wiring Diagram..... 21

Gen 5 Super Wiring Connection Instruction..... 22

Operation of Controls..... 23

Troubleshooting Guide..... 24

Troubleshooting Guide (Cont.), Advanced Diagnostics and Troubleshooting Guide..... 25

Packing List..... 26

## Additional Parts - Please Read

- The **Optional** Defrost Grille Kit, Vintage Air PN# 633816, is an additional part designed to be used in conjunction with the Universal 2 1/2" Defrost Duct Kit, Vintage Air PN# 633814.



www.vintageair.com

## Packing List: Evaporator Kit (681000)

No.	Qty.	Part No.	Description
1.	1	681111	Super Gen 5 with Defrost Sub Case
2.	18'	06250-VUE	Duct Hose, 2 1/2"
3.	1	235000	Wiring Kit, Gen 5 Universal
4.	1	633814	Defrost Duct Kit, Universal 2 1/2"
5.	1	637100	Installation Kit

**\*\* Before beginning installation, open all packages and check contents of shipment. Please report any shortages directly to Vintage Air within 15 days. After 15 days, Vintage Air will not be responsible for missing or damaged items.**

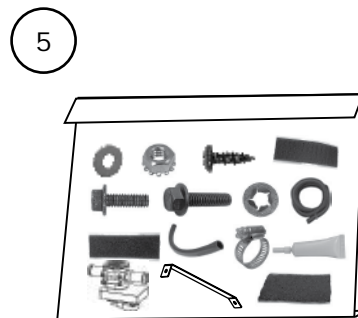
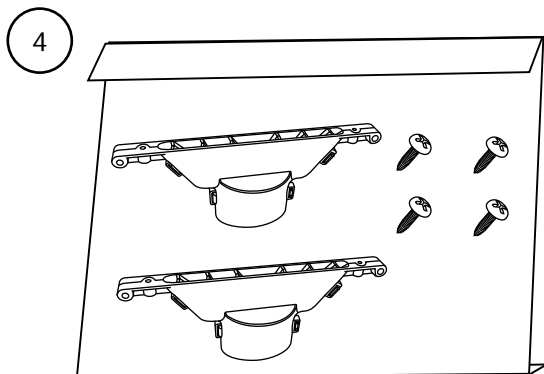
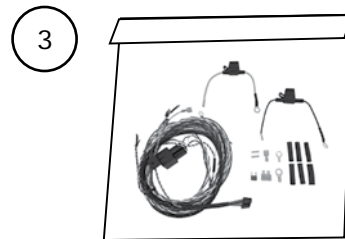
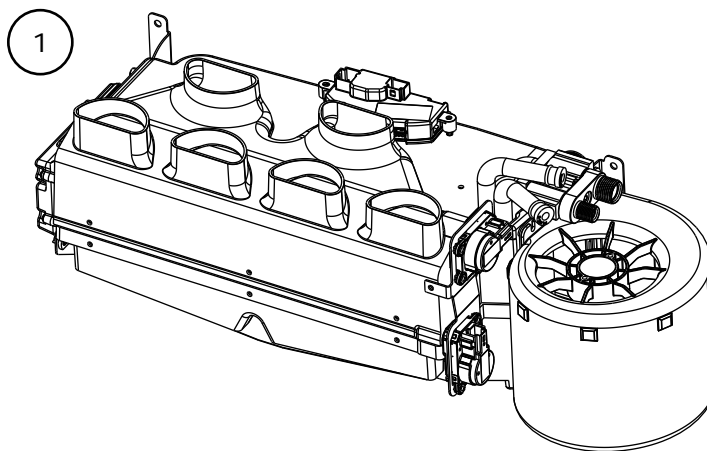

**NOTE: Images may not depict actual parts and quantities. Refer to packing list for actual parts and quantities.**



www.vintageair.com

## Important Notice—Please Read

*For Maximum System Performance, Vintage Air Recommends the Following:*

**NOTE:** Vintage Air systems are designed to operate with R134a refrigerant only. Use of any other refrigerant could damage your A/C system and/or vehicle, and possibly cause a fire, in addition to potentially voiding the warranties of the A/C system and its components.

### Refrigerant Capacities:

**Vintage Air System:** 1.8 lbs. (28.8 oz.) or 816 grams of **R134a**, charged by weight with a quality charging station or scale. **NOTE: Use of the proper type and amount of refrigerant is critical to system operation and performance.**

**Other Systems:** Consult manufacturer's guidelines.

### Lubricant Capacities:

**New Vintage Air-Supplied Sanden Compressor:** No additional oil needed (Compressor is shipped with proper oil charge).

**All Other Compressors:** Consult manufacturer (Some compressors are shipped dry and will need oil added).

### Safety Switches

Your Vintage Air system is equipped with a binary pressure safety switch. A binary switch disengages the compressor clutch in cases of extreme low pressure conditions (refrigerant loss) or excessively high head pressure (406 PSI) to prevent compressor damage or hose rupture. A trinary switch combines Hi/Lo pressure protection with an electric fan operation signal at 254 PSI, and should be substituted for use with electric fans. Compressor safety switches are extremely important since an A/C system relies on refrigerant to circulate lubricant.

### Service Info:

**Protect Your Investment:** Prior to assembly, it is critical that the compressor, evaporator, A/C hoses and fittings, hardlines, condenser and receiver/drier remain capped. Removing caps prior to assembly will allow moisture, insects and debris into the components, possibly leading to reduced performance and/or premature failure of your A/C system. This is especially important with the receiver/drier.

Additionally, when caps are removed for assembly, **BE CAREFUL!** Some components are shipped under pressure with dry nitrogen.

**Evacuate the System for 35-45 Minutes:** Ensure that system components (Drier, compressor, evaporator and condenser) are at a temperature of at least 85°F. On a cool day, the components can be heated with a heat gun **or** by running the engine with the heater on before evacuating. Leak check and charge to specifications.

### Bolts Passing Through Cowl and/or Firewall:

To ensure a watertight seal between the passenger compartment and the vehicle exterior, for all bolts passing through the cowl and/or firewall, Vintage Air recommends coating the threads with silicone prior to installation.

### Heater Hose (not included with this kit):

Heater hose may be purchased from Vintage Air (Part#31800-VUD) or your local parts retailer. Routing and required length will vary based on installer preference.



www.vintageair.com

## Important Wiring Notice—Please Read

*Some vehicles may have had some or all of their radio interference capacitors removed. There should be a capacitor found at each of the following locations:*

- 1. On the positive terminal of the ignition coil.**
- 2. If there is a generator, on the armature terminal of the generator.**
- 3. If there is a generator, on the battery terminal of the voltage regulator.**

Most alternators have a capacitor installed internally to eliminate what is called “whining” as the engine is revved. If whining is heard in the radio, or just to be extra cautious, a radio interference capacitor can be added to the battery terminal of the alternator.

It is also important that the battery lead is in good shape and that the ground leads are not compromised. There should be a heavy ground from the battery to the engine block, and additional grounds to the body and chassis.

If these precautions are not observed, it is possible for voltage spikes to be present on the battery leads. These spikes come from ignition systems and charging systems, and from switching some of the vehicle’s other systems on and off. Modern computer-operated equipment can be sensitive to voltage spikes on the power leads, which can cause unexpected resets, strange behavior and/or permanent damage.

Vintage Air strives to harden our products against these types of electrical noise, but there is a point where a vehicle’s electrical system can be degraded so much that nothing can help.

Radio interference capacitors should be available at most auto and truck parts suppliers. They typically are cylindrical in shape, a little over an inch long and a little over a half-inch in diameter, and they have a single lead coming from one end of the cylinder with a terminal on the end of the wire, as well as a mounting clip which is screwed into a good ground on the vehicle. The specific value of the capacitance is not too significant in comparison to ignition capacitors that are matched with the coil to reduce pitting of the points.

- Care must be taken, when installing the compressor lead, not to short it to ground. The compressor lead must not be connected to a condenser fan or to any other auxiliary device. Shorting to ground or connecting to a condenser fan or any other auxiliary device may damage wiring or the compressor relay, and/or cause a malfunction.
- When installing ground leads on Gen 5 systems, the blower control ground and ECU ground must be connected directly to the negative battery post.
- For proper system operation, the heater control valve must be connected to the ECU.



www.vintageair.com

## Additional Parts and Components for Universal Installations

- Additional parts and components that were designed for specific kits may fit other applications and are shown on the website and in our catalog. Some of the parts and components include: insulation materials, under dash louvers, louver hose adapters, defrost ducts, electronic control panels, Magnum plenums, grommets, firewall and kick panel rubber boots, etc.

### Under Dash Louvers

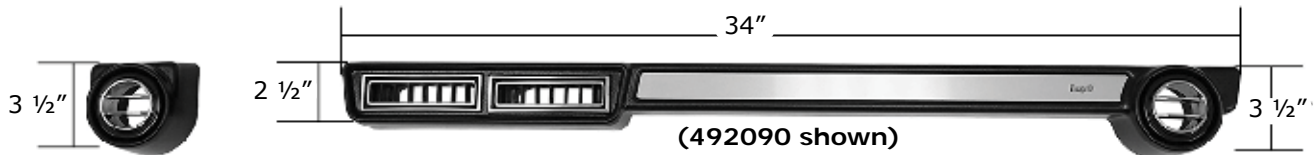

### Rubber Boots

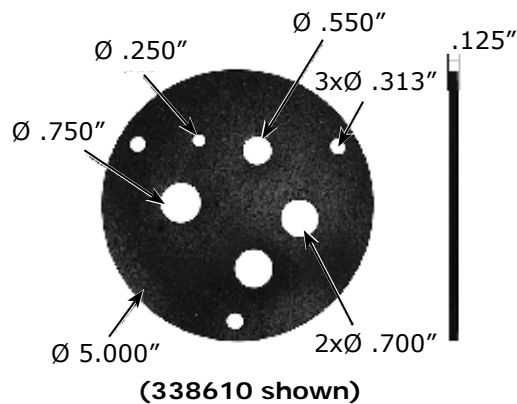

### Control Panels

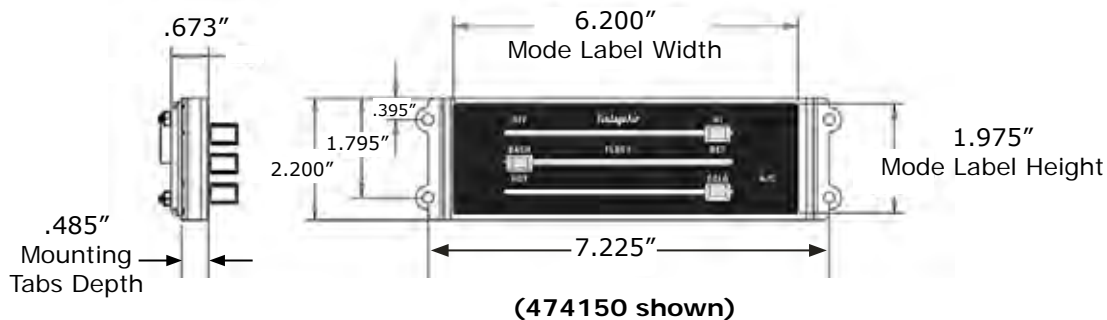

### Defrost Ducts and Hose Adapters

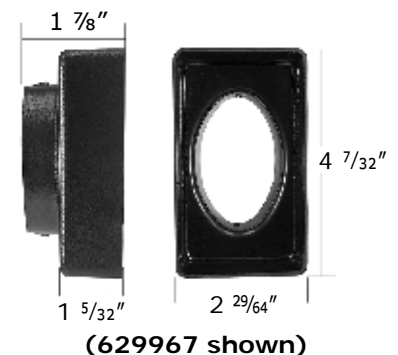
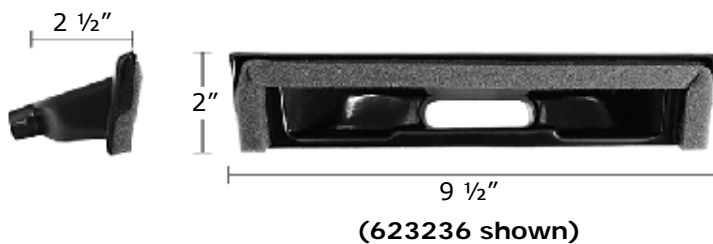



www.vintageair.com

## Evaporator Dimensions

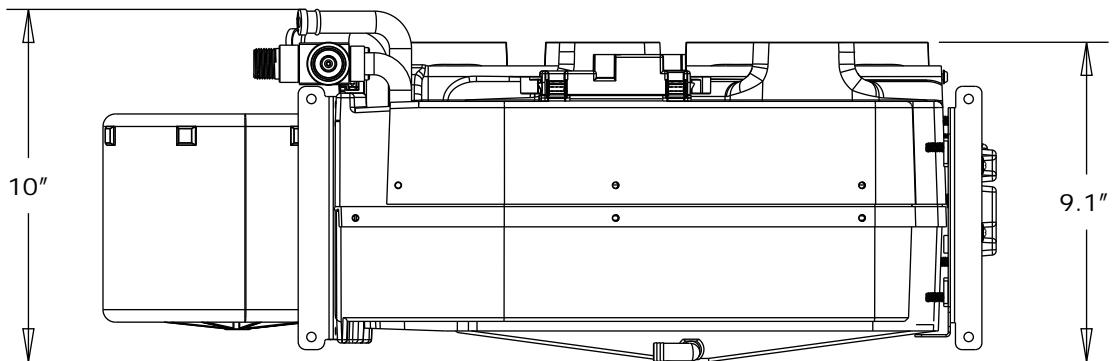
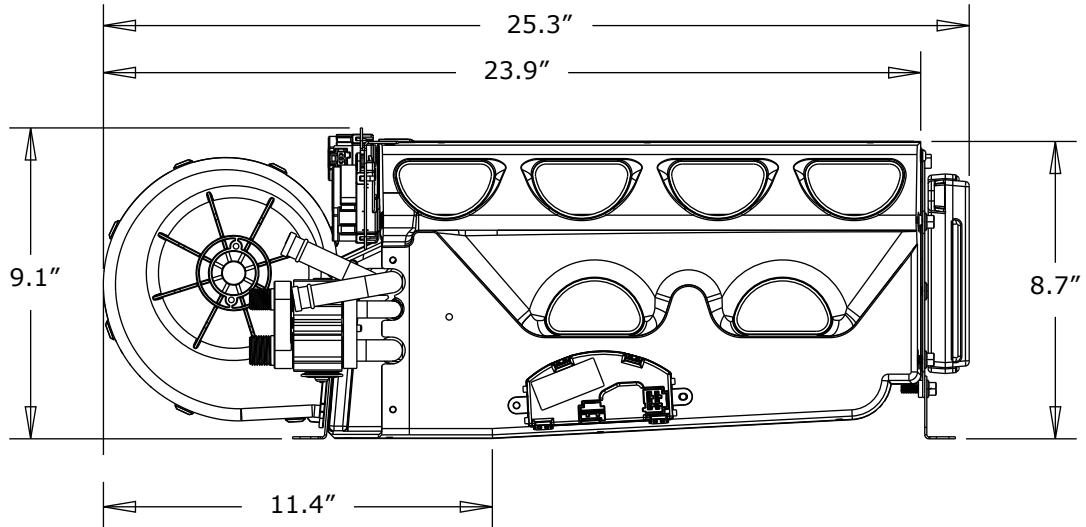



www.vintageair.com

## Planning Overview

- Every vehicle is different depending on the:
  1. Type of vehicle/engine and location of engine.
  2. Type of air conditioning equipment used.
  3. Owner's preferences.
- There are many factors that go into making each air conditioning installation different. Usually, all of the above decisions are made before any consideration is given to the air conditioning installation. The A/C system is then tailored to fit your particular application.
- The mounting location of the evaporator module is determined in part by the space available for the hose routing. The components used in the hose routing process (i.e. bulkhead plates, fittings, grommets, etc.) will also influence the location of the evaporator module. When planning your hose routing, you must install the major component parts first. Mount the compressor, condenser and drier. The evaporator must be temporarily held in position under the dash. Final mounting of the evaporator to the firewall should not be done until you have verified that all hoses attaching to the evaporator will exit the firewall and/or kick panel as planned. The hoses must be run exactly the way they will be when finished, before cutting them to length.
- Duct hose routing and A/C vent locations should also be given careful consideration before final mounting position of the evaporator is selected.
- The Vintage Air Gen 5 Super Evaporator Module was designed for classic cars, custom cars, and trucks. The evaporator module is designed to mount behind the dash.
- Read the installation instructions completely, and familiarize yourself with all the parts, photos and illustrations.
- The installation of this module varies according to the body manufacturer or modifications to the original body. Take your time, and double check before drilling or cutting.
- For proper system operation, Vintage Air recommends using heat-blocking insulation in the area around the evaporator module (firewall, kick panel, inner cowl, firewall covers) (See Photos 1 and 2, below). To ensure a watertight seal between the passenger compartment and the vehicle exterior, for all bolts passing through the firewall, Vintage Air recommends coating the threads with silicone prior to installation.



Before Insulation

Photo 1

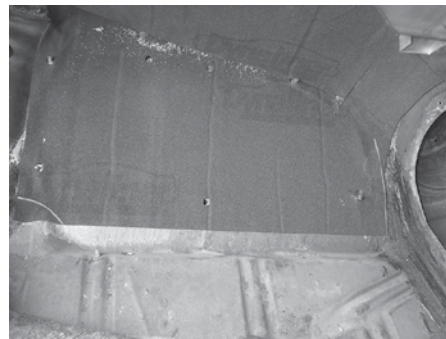

After Insulation

Photo 2



www.vintageair.com

## Planning Overview (Cont.)

- The installation of this module varies, according to the body manufacturer or modifications to the original body. The cowl vent may remain operational. Take your time, and double check before drilling or cutting.
- Before beginning, remove cowl vent handle and glove box to ease installation. If the dash is easily removable, remove it now. Check for, and fill in any holes in the firewall and floor. Insulate and seal firewall, floor, door panels, and headliner to reduce the amount of heat entering the car. Figures 1 and 2, show the general location of the defrost ducts. Locations will vary. If your module is equipped with the defrost option, install the ducts now.

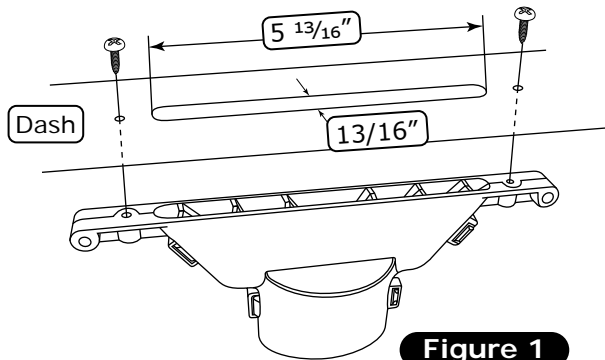

Figure 1

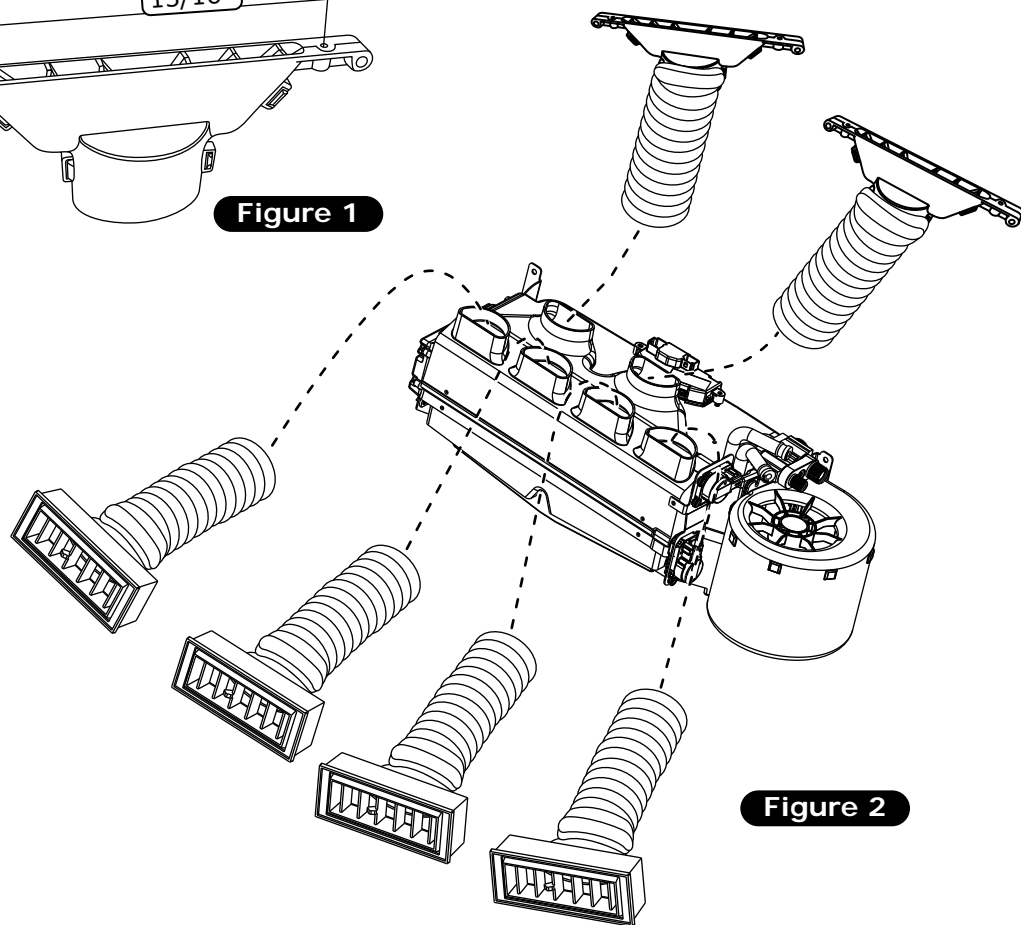

Figure 2

## Condenser Assembly & Installation

1. Refer to separate instructions included with the condenser kit.

## Compressor and Brackets

1. Refer to separate instructions included with the bracket kit.



www.vintageair.com

## Installation Steps

1. Mount the compressor on the engine. Follow the instructions included with the compressor bracket kit.
2. Mount the condenser in the proper location.
3. Brackets are furnished to mount the evaporator case. Attach to the firewall as shown in Figure 1, below.
4. The cowl vent handle will work if moved to the side. You can also convert to electric or cable operation. If you close off the cowl vent, the module will fit higher in the car. **NOTE: To mount the module higher, simply determine the new location, mark and re-drill the bracket to fit as described in Step 6 (See Figure 1, below). Be sure to allow sufficient clearance for routing the duct hoses.**
5. When fitting the evaporator test fit the refrigeration fittings with hoses for proper clearance inside the car. Refer to Hose Routing Diagram, Page 14.
6. Have a helper hold the module up as high as possible, with the blower housing against the passenger-side kick panel. Locate the bracket on the right side of the blower housing with a hole above and below the blower. Scribe through the upper 1/4" hole in the bracket to mark the firewall. Check to see if the location you marked looks correct and will clear obstructions on both sides of the firewall. If so, drill a 9/32" hole in the firewall. Align the evaporator to the firewall by the upper hole of the blower motor bracket with a 1/4-20 x 3/4" bolt, pushnut, washer and nut as shown in Figure 2, Page 11. Level the evaporator module, and use the 1/4" hole in the evaporator driver-side bracket as a guide, mark and drill a 9/32" hole in the firewall. Attach this bracket to the firewall with a 1/4-20 x 3/4" bolt. This will locate the evaporator horizontally. Drill (2) more holes in the firewall using the lower hole in both brackets to mark the centers.

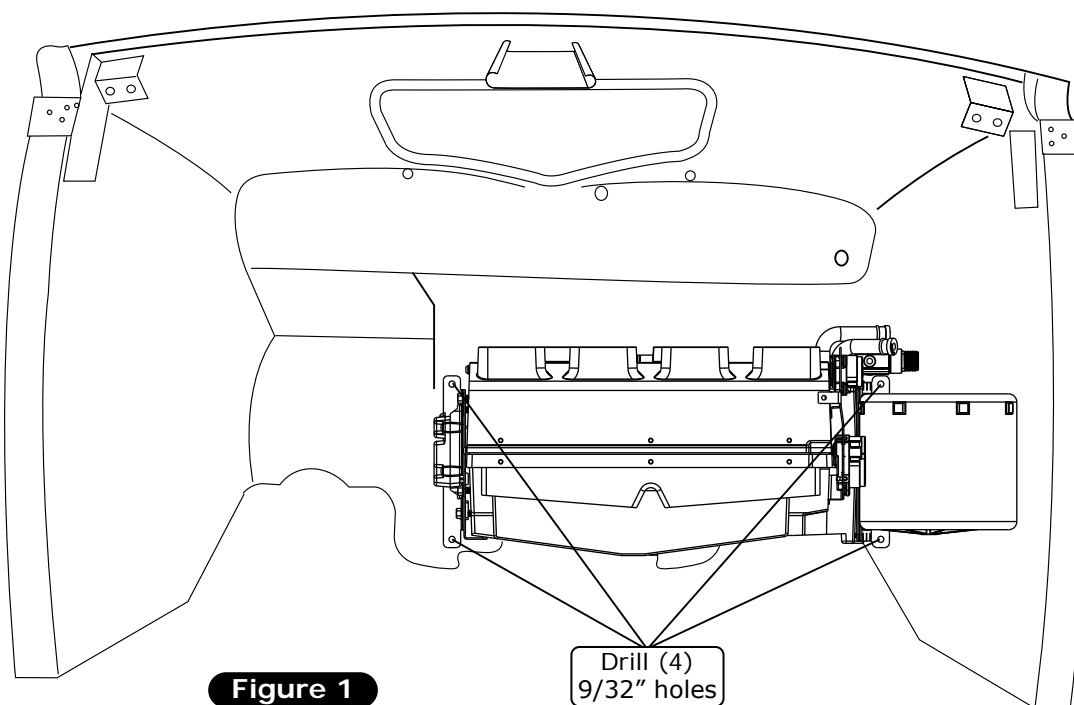



www.vintageair.com

## Installation Steps (Cont.)

7. The 1/4-20 x 3/4" serrated flange black bolt, 1/4" pushnut bolt retainer, 1/4" USS flat washer and 1/4-20 hex nut with star washer shown in Figure 2, below, on the lower left mounting ear of the evaporator will be repeated four times to secure the case through the .281" holes drilled through firewall.
8. The (2) bolts factory installed through the slotted slide bracket to the driver-side case mounting bracket can be adjusted by the customer to the perfect fit of the case against the firewall. This slot gives the driver side of the case about 9/16" of fore/aft adjustment while the passenger-side mounting points remain fixed. This means that the case can pivot slightly about the (2) passenger-side bolts before all (4) bolts are tightened.
9. In conjunction with the (4) firewall mounting points, we've provided a single mounting point for securing the evaporator to the dash. Secure the evaporator front bracket to the weld nut on the driver-side case bracket down low near the floor duct as shown in Figure 2, below. **NOTE: Use this evaporator front bracket as-is, modify it, or fabricate a custom dash bracket to fit properly.** The dash mounting bracket is secured to the case and dash using 1/4-20 x 3/4" serrated flange black bolt, same as at the firewall.
10. Do not route hoses directly above ECU. This will prevent any possible condensation formation from dripping from the duct hoses onto the ECU.

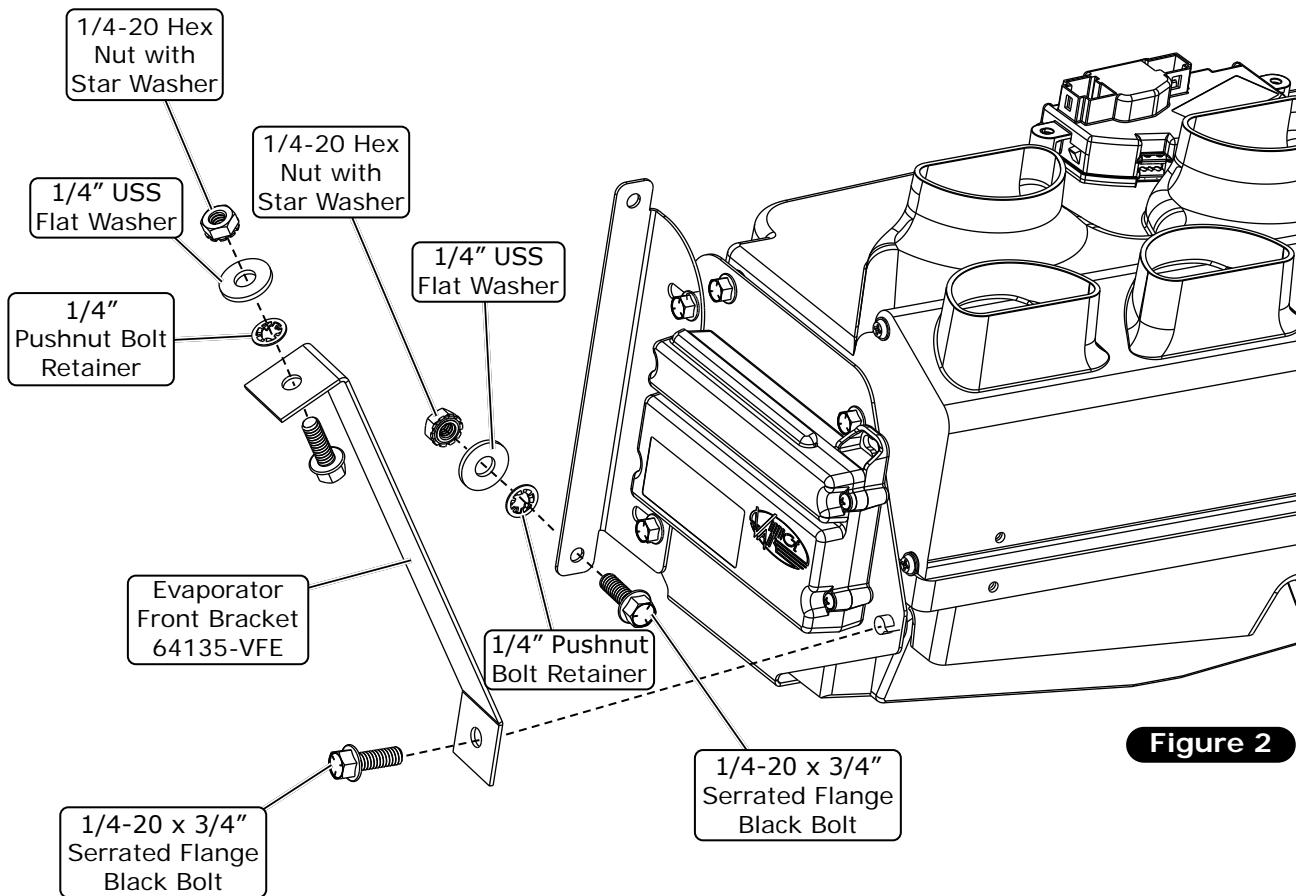

Figure 2



www.vintageair.com

## Installation Steps (Final)

11. Push the 5/16" I.D. hose onto the straight #6 fitting (See Hose Routing Diagram, Page 14). Install the fitting onto the block valve (finger tight). Push the 1/2" I.D. hose onto the straight #10 fitting, and install the fitting onto the #10 line on the evaporator (See Hose Routing Diagram, Page 14).
12. At this time, try to determine where you want your lines to go through the firewall. Move the hoses to that point. Hold the fittings up to their respective hoses, and determine if the hoses will conform to the location for the bulkhead fittings or optional bulkhead plate (Vintage Air PN #34215-VUQ or 34218-VUQ). The 1/2" hose is hard to bend at a sharp angle, and the fittings take up a certain amount of space. **NOTE: Before you drill holes in your firewall, make sure that you can make the hoses fit where you have planned.** The engine compartment appearance is a consideration when choosing this location.
13. When you have decided where you want to place your bulkhead fittings, mark these points with a grease pencil, and make a template from the inside locating where the holes will be cut. With this template, locate the same points on the outside of the firewall and mark these points with a grease pencil.
14. Determine the best location for the drier that will allow adequate room for the hose and fittings that connect the drier to the bulkhead fitting.
15. Mount the drier. Keep the drier capped as much as possible, if you must screw the fitting to the drier, tape it closed. **NOTE: The drier is usually mounted where you have room for it. Just remember to mount it in the coolest spot possible and vertically so the sight glass is directly on top, not next to the exhaust manifold. It can be mounted inside the vehicle as well.**
16. At this point, cut holes for bulkhead fittings and install them.
17. Using the hose routing diagram on Page 14 as a guide, route the remaining A/C lines and cut to length.
18. Install the A/C vents that will be used at this time.
19. Center Outlet: You may use the center panel furnished, or you can mount the vents in the dash. If you use the control panel, the top mounting lip should be back 1/4" to 1/2" from the lower leading edge of the dash. Locate the 2 1/2" I.D. hose, and route from the dash vents to the evaporator.
20. At this time, you should have the refrigeration hoses cut to their proper length. **NOTE: Pay close attention to the orientation of any hose with two angled fittings.** Any hose with two angled fittings must be marked from the hose to the fittings to assure they will remain in this position after crimping. The rubber hose is only capable of a minimal amount of twist to aid alignment.
21. Remove hoses and crimp ends. If you do not have access to the proper equipment, you must take them to a qualified A/C service center for crimping (See crimping instructions supplied with the hose kit).
22. With the evaporator trial fit complete, you may remove the module and lower in vehicle.
23. After crimping hoses, locate the #6 A/C hose with the straight fitting. Lubricate a #6 A/C O-ring and the threads on the fitting (See Lubricating O-rings, Page 15), and install on the block valve. Tighten carefully.
24. Locate the #10 A/C hose with the straight fitting. Lubricate a #10 O-ring and the threads on the fitting (See Lubricating O-rings, Page 15), and install on the #10 line of the evaporator. Tighten carefully.
25. Wrap the #10 fitting with press tape, and cover all exposed metal surfaces. **NOTE: Do not wrap the #6 hose, fitting, or the heater core tubes.**
26. With refrigeration hoses and duct hoses on the module, lift it in place. Make sure that the firewall fittings are accessible with the module in place. If not, tighten all refrigeration fittings inside the car now, while you can reach them. Lift the module into place, and tighten the bracket bolts to secure to the evaporator.
27. Route heater hoses (Refer to Heater Hose Routing Diagram, Page 14).
28. With your module in place, stretch the duct hose tightly to the dash vent, and recheck the length. Trim to ensure that the hose is taut, with a minimum of kinks or sharp bends in the hose. This will ensure maximum airflow.
29. Make electrical connections, according to the diagram furnished on Page 21.



www.vintageair.com

## Drain Hose Installation

1. Drill a 5/8" hole through your preferred point of exit from the vehicle. Typical locations include the firewall, kick panel or floorboard. **NOTE: When determining drain location, consider the following: Drain hose must be installed with a minimum 1" drop from the drain nipple on the bottom of the evaporator case to the point where the drain hose exits the vehicle. Also, be sure to route the drain hose such that water drips directly onto the ground, rather than on any part of the vehicle frame.**
2. Install the drain hose onto the drain nipple on the sub case, and route the hose through the hole drilled in Step 1, above.

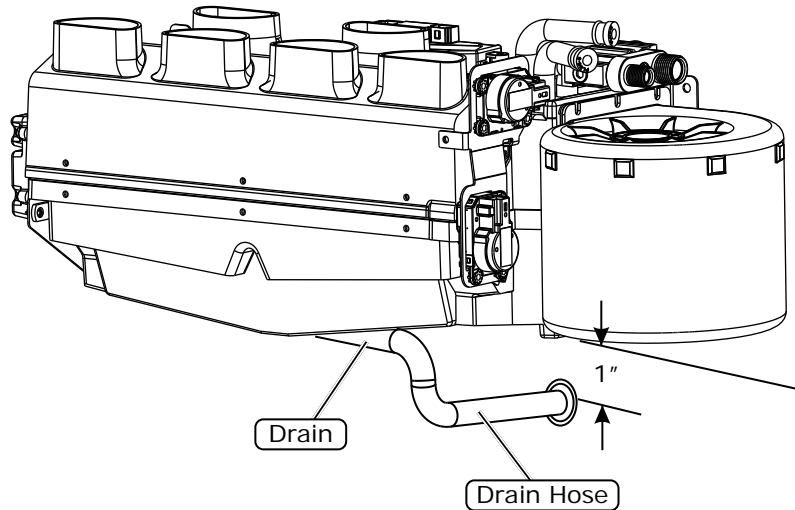



www.vintageair.com

# Hose Routing Diagram

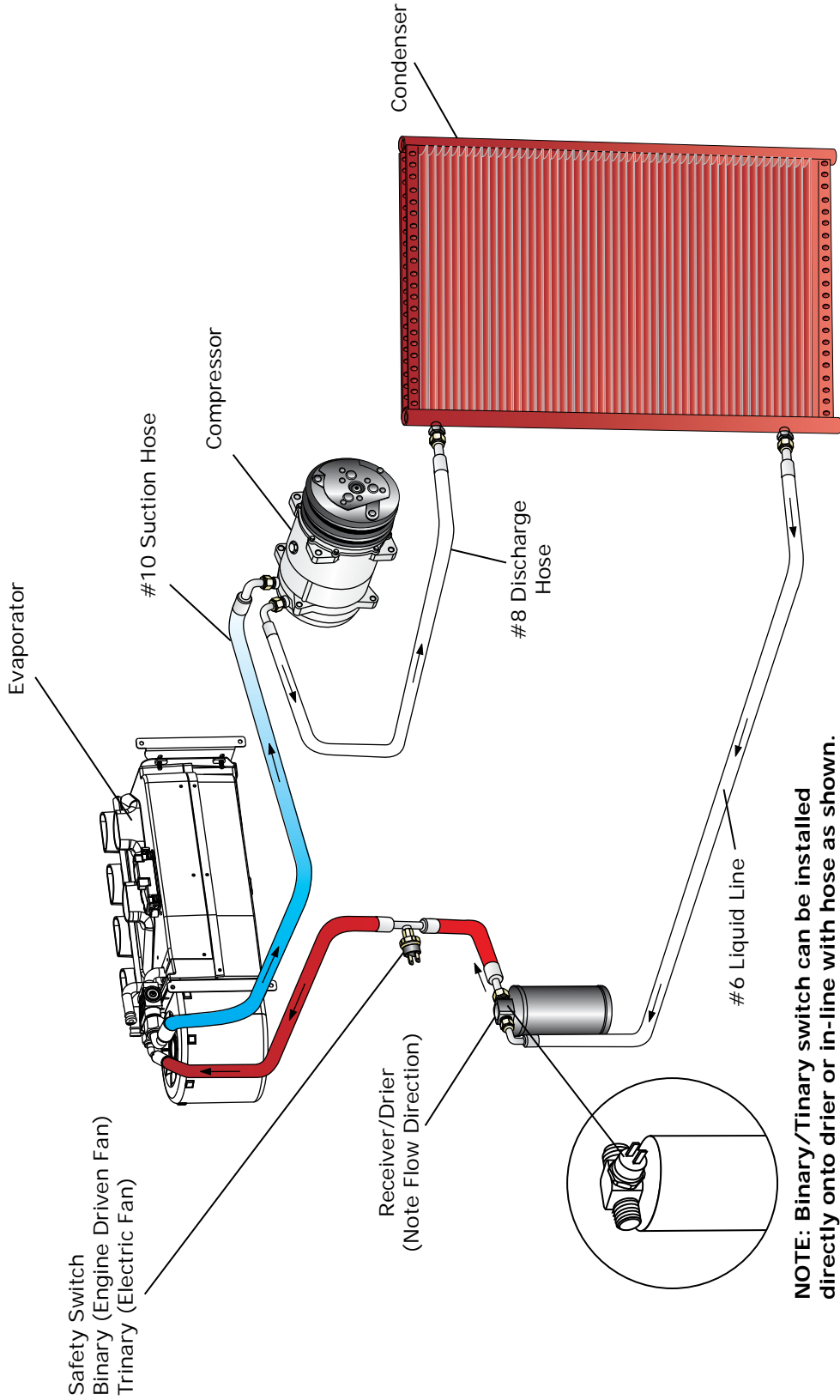

**NOTE: Binary/Tinary switch can be installed directly onto drier or in-line with hose as shown.**

**NOTE: Direction of refrigerant flow indicated by arrows.**



www.vintageair.com

## Duct Hose Routing and ECU Relocation

**NOTE:** For the system to function optimally, the duct hoses must be routed as directly as possible, taking care to avoid kinks, sharp bends and unnecessary length. Vintage Air supplies duct hoses in continuous lengths that will need to be cut to size depending on application. Before cutting, familiarize yourself with the installation instructions and verify the routing will work with your application. For custom hose routing, additional hose may be needed and can be purchased from Vintage Air. For best airflow, do not cap the outlets.

1. Stretch the duct hose until there is no slack, measure, mark and cut hose to size (See Photo 1, below).

Stretch, measure, mark and cut hose to size

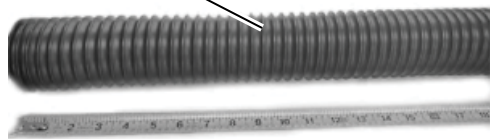
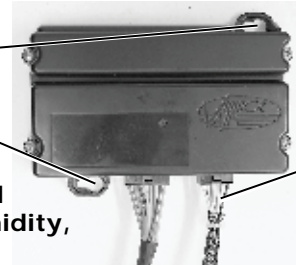

Photo 1

(2) #8 x 1/2" pan head screws or Velcro to relocate ECU if needed



Position connectors towards bottom

**NOTE:** ECU must be placed away from water and humidity, and also be accessible for servicing. If relocating, connectors must be positioned towards the bottom.

Photo 2

## Lubricating O-rings

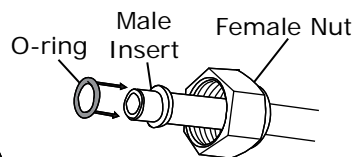
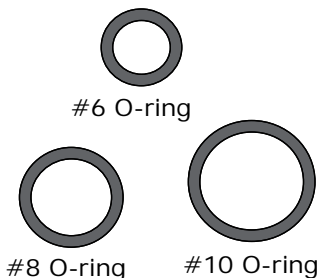

For a proper seal of fittings: Install supplied O-rings as shown and lubricate with refrigerant oil.

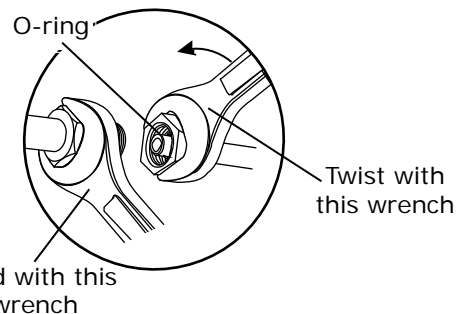
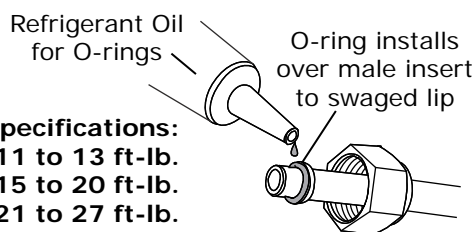

**NOTE: Standard torque specifications:**  
 #6: 11 to 13 ft-lb.  
 #8: 15 to 20 ft-lb.  
 #10: 21 to 27 ft-lb.

## Properly Seated O-ring Land

When installing a hardline or A/C hose fitting onto the evaporator module, ensure the O-ring land is seated properly (See Photo 1, below). An improperly seated O-ring land (See Photo 2, below) can cause a leak. To properly install the fitting, slide the hardline or A/C hose nut back to expose the O-ring land and seat it onto the evaporator module fitting. Then, slide the hardline or A/C hose nut forward and thread it onto the evaporator module fitting, ensuring the O-ring land does not move or lift.

Properly Seated O-ring Land



Photo 1

Improperly Seated O-ring Land



Photo 2

**NOTE:** Photos shown are for reference only. Fittings may vary depending on kit received.



www.vintageair.com

## Heater Hose Installation/Final Steps

1. After the evaporator is in place, run 5/8" heater hose from the heater tube nearest the blower on the evaporator through the firewall or behind the kick panel through the floor to the intake manifold heater connection. Install the heater control valve in this line (pressure) (See Figure 1, below). **NOTE: Be sure to follow flow arrow on heater control valve.**
  2. Install 5/8" heater hose on the remaining heater tube. Route hose through the firewall or behind the kick panel through the floorboard and out to the water pump connection (suction).
  3. Fill the radiator with at least a 50/50 mixture of approved antifreeze and distilled water. It is the owner's responsibility to keep the freeze protection at the proper level for the climate in which the vehicle is operated. Failure to follow the antifreeze recommendations will cause the heater core to corrode prematurely and possibly burst in A/C mode and/or freezing weather, voiding your warranty. Check complete A/C assembly for proper operation. Vintage Air recommends that all A/C systems be serviced by a certified automotive air conditioning technician. See inside cover for service information. **NOTE: Prior to charging the A/C system, run the engine and cycle the heater control valve to circulate the antifreeze through the heater core.**
  4. Start the engine and run until normal operating temperature is reached. Place switch in heat position (See Operation of Controls, Page 24), and select fan speed desired. The system will heat the vehicle. **NOTE: Be sure the engine thermostat has opened, and the approved antifreeze mixture has been circulated through the heater core before testing the A/C modes.**
  5. When valve is closed, inlet side of valve should be hot and outlet side should be cool. When the valve is open, both inlet and outlet sides should be hot.
  6. If previously removed, reinstall the dash and ensure that the duct hose is securely on the dash vent hose adapters.
- NOTE: Don't forget to wrap any exposed #10 fittings inside the car to prevent condensation.**
7. Install the duct hoses as shown in Figure 1, Page 15. Stretch the duct hose tightly to the dash vents. Trim to ensure that the duct hose is tight, with as few kinks or sharp bends in the hose as possible. This will ensure maximum airflow.
  8. Install the control panel. Refer to the control panel kit instructions.
  9. Route the control panel harness assembly and connect it to the PC board assembly on the back side of the control panel.
  10. Plug the wiring harness into the ECU module on the sub case.. Wire according to the wiring diagram on Page 21.
  11. Reinstall all previously removed items.
  12. Double check all fittings, brackets and belts for tightness.
  13. Evacuate the system for a minimum of 45 minutes prior to charging, and leak check prior to servicing. Charge the system to the capacities stated on the information page, Page 4, of this instruction manual.

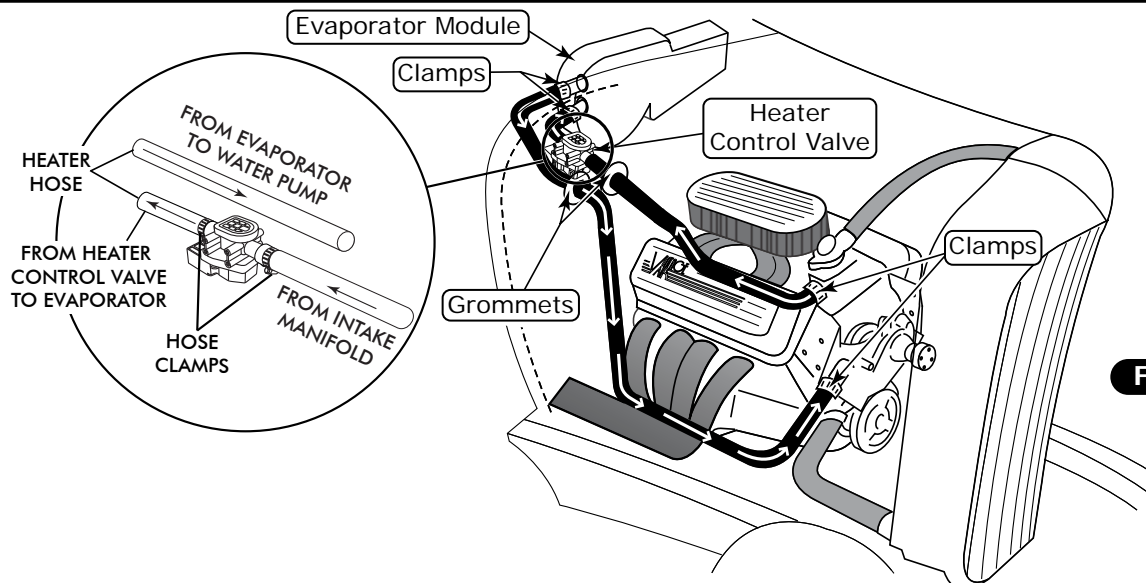

Figure 1



www.vintageair.com

# Engine Compartment Wiring

**NOTE: The following connections are critical to the performance of the system. Before making connections, refer to the Quality Crimp Guidelines, Page 20.**

1. Route power and ground wires toward the battery (See Photo 1, below).
2. Install the supplied heat shrink over the 12 AWG orange standard fuse holder assembly wire and crimp it to the 12 AWG orange wire from the main wiring harness (See Photo 2, below). Slide the heat shrink over the crimp, then apply heat.
3. Install the supplied heat shrink over the 16 AWG black mini fuse holder assembly wire and crimp it to the 16 AWG red wire from the main wiring harness (See Photo 3, below). Slide the heat shrink over the crimp, then apply heat.
4. Install the fuses into the holders (See Photos 4 and 5, below).
5. Install the supplied heat shrink over the white ground wires, then crimp on the supplied ring terminals (See Photo 6, below). Slide the heat shrink over the crimps, then apply heat. **NOTE: Both white wires can be crimped to the larger ring terminal. Install the heat shrink, then strip the wires, twist them together and trim to length. Crimp on the ring terminal, then slide the heat shrink over and apply heat (See Photos 7 and 8, below).**

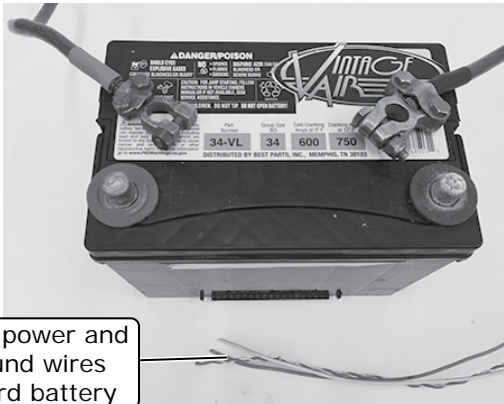

Route power and ground wires toward battery

Photo 1

Crimp 12 AWG orange fuse holder wire to 12 AWG orange wire from main wiring harness



Photo 2

Install heat shrink over 12 AWG orange standard fuse holder assembly wire

Crimp 16 AWG black fuse holder wire to 16 AWG red wire from main wiring harness



Photo 3

Install heat shrink over 16 AWG black standard fuse holder assembly wire

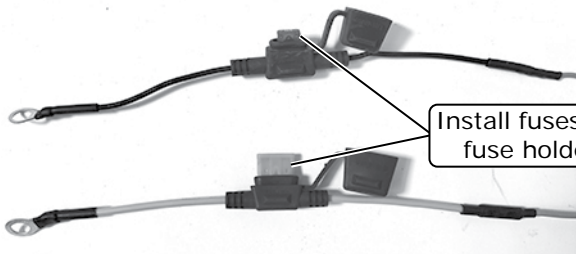

Install fuses into fuse holders

Photo 4



Both white ground wires can be crimped together. Install heat shrink, then strip wires, twist together and trim to length.

Photo 5

Install heat shrink over white ground wires, then crimp on ring terminals

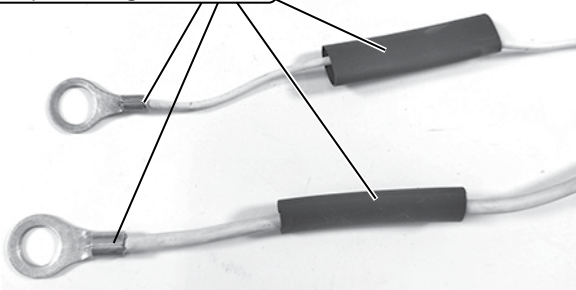

Photo 6

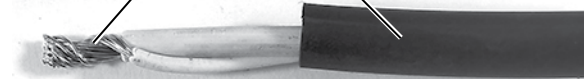

Photo 7

Crimp on ring terminal, then slide heat shrink over and apply heat



Photo 8



www.vintageair.com

## Engine Compartment Wiring (Cont.)

6. Connect the ground wire ring terminals to the negative battery terminal connector (See Photos 9 and 10, below).
7. Connect the positive wire ring terminals to the positive battery terminal connector (See Photos 11 and 12, below). **NOTE: Do not connect power until the installation is completed.**
8. Wiring completed (See Photo 13, below).

Connect ground wire ring terminals to negative battery terminal  
**NOTE: Either connection application can be used.**

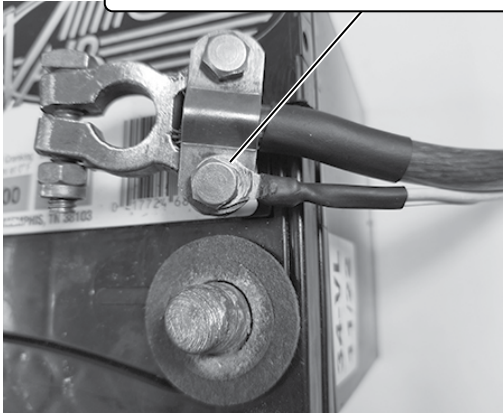

Photo 9

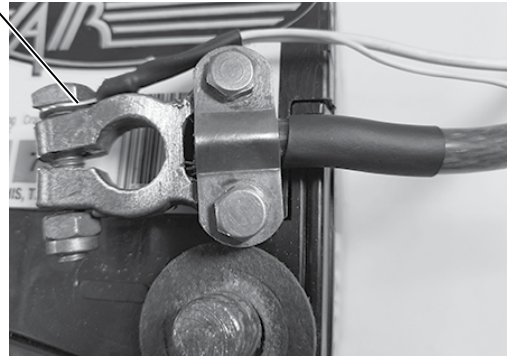

Photo 10

Connect power wire ring terminals to positive battery terminal  
**NOTE: Either connection application can be used.**

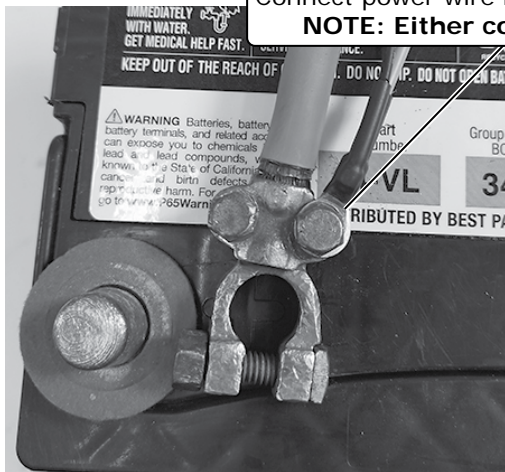

Photo 11

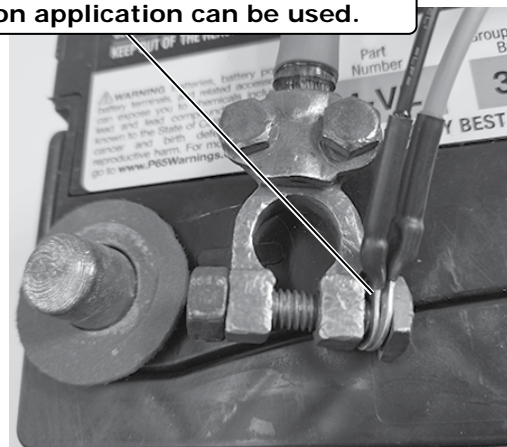
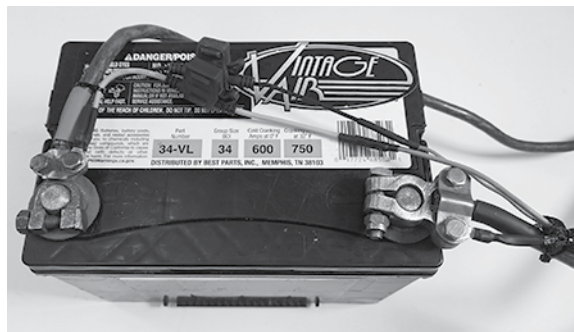

Photo 12

**NOTE: Do not connect power until installation is completed.**



Completed Installation Shown

Photo 13



www.vintageair.com

# Final Steps: Installation Check

Installation Check	
ITEM TO CHECK	Procedure
<input type="checkbox"/>	<p>ECU</p> <p>If no blinking is observed after 1 minute of turning the ignition on, go to the next check.</p> <p>If repetitive blinking is observed, go to the <b>Advanced Diagnostics</b> Section to diagnose.</p>
<input type="checkbox"/>	<p>Blower speed control</p> <p>Set the blower speed control to <b>OFF</b>, <u>confirm that the blower is off</u>.</p> <p>Position the blower speed control to <b>LOW</b> then <b>MEDIUM</b> and then <b>HIGH</b>. <u>At each setting confirm that the blower speed increases</u>, do this by feeling for the amount of air coming from the unit and hearing the blower speed increase.</p>
<input type="checkbox"/>	<p>Mode control</p> <p>Set the <b>MODE</b> control to the <b>DASH</b> position. <u>Confirm that air is being blown at the dash vents</u>.</p> <p>Set the <b>MODE</b> control to the <b>FLOOR</b> position. <u>Confirm that air is being blown at the floor vents</u>.</p> <p>Set the <b>MODE</b> control to the <b>DEFROST</b> position. <u>Confirm that all air is being blown from the defrost vents</u></p> <p><b>If heater lines are installed:</b></p> <p>Set the <b>MODE</b> control to the <b>DASH</b> position. Set the <b>TEMP</b> control to the <b>MAX HEAT</b> position. <u>Confirm that HOT air is coming from the dash vents</u>.</p>
<input type="checkbox"/>	<p>Temperature control</p> <p><b>If system is charged:</b></p> <p>Set the <b>TEMP</b> control to the <b>MAX COOL</b> position. <u>Confirm that COLD air is coming from the dash vents</u>.</p> <p>Also <u>confirm that the compressor "clicks" on</u> when adjusting the <b>TEMP</b> control from the <b>MAX HEAT</b> position to the <b>MAX COOL</b> position.</p>
<input type="checkbox"/>	<p>AC Indicator (If applicable)</p> <p>While the <b>MODE</b> control is set to the <b>DASH</b> position, and the <b>TEMP</b> control is set to the <b>MAX COOL/MIN HEAT</b> position, <u>confirm that the blue AC Indicator light is on</u>.</p>
<input type="checkbox"/>	<p>Backlight (If applicable)</p> <p>If your control panel has backlight capabilities and has been wired, turn the dash lamp on and <u>confirm that the AC panel's legend is lit</u>.</p>
<input type="checkbox"/>	<p>Fittings</p> <p>Verify AC and Heater fittings are all tight.</p>



www.vintageair.com

# Quality Crimp Guideline

Acceptable strip length  
(Some copper visible)

Crimped area is centered  
on each side of splice

Bad strip length  
(Too much copper visible)  
Visible copper should be  
just enough to ensure  
clearance between splice  
area and wire insulation

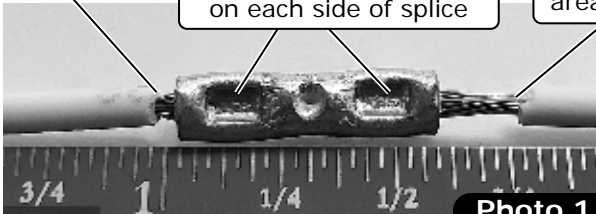

**Photo 1**

A good crimp requires  
seam of butt splice to be  
opposite of crimp die tooth



**Photo 2**

## Good Ring Terminal Crimp    Bad Ring Terminal Crimp



Crimped  
area is  
opposite  
of seam

**Photo 3**

Crimp  
area is  
centered  
on barrel

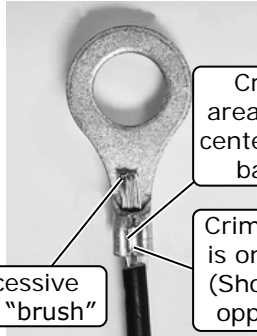

Crimp  
area is not  
centered on  
barrel

Excessive  
wire "brush"

**Photo 4**

Crimp area  
is on seam  
(Should be  
opposite)

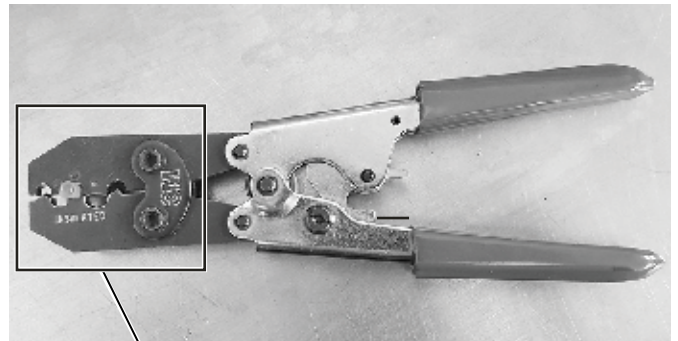

**Photo 5**

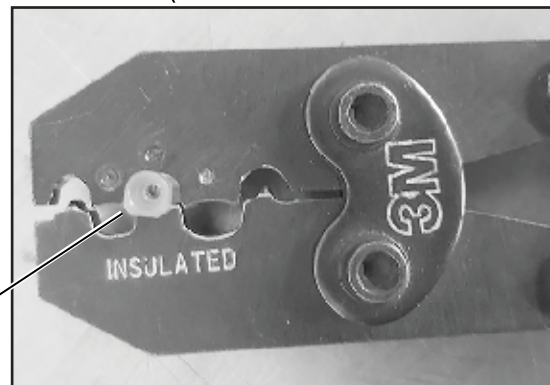

**Photo 5a**

Use a ratcheting crimp tool  
for insulated barrel terminals  
when crimping the provided  
female insulated terminal.  
Ensure terminal is inserted in  
appropriate position before  
crimping.



www.vintageair.com

# Gen 5 Super Wiring Diagram

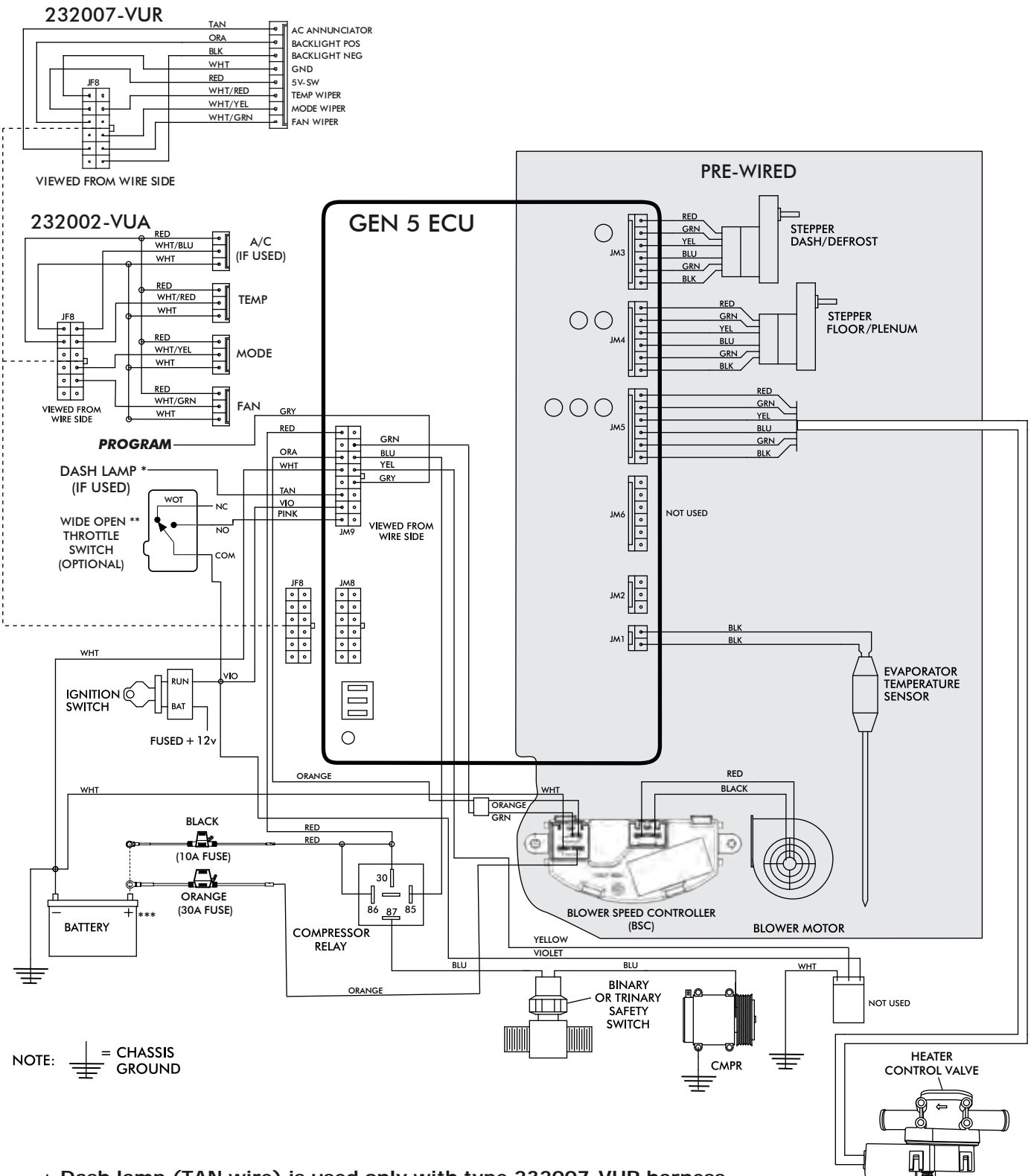

NOTE: = CHASSIS GROUND

- \* Dash lamp (TAN wire) is used only with type 232007-VUR harness.
- \*\* Wide open throttle switch contacts close only at full throttle, which disables A/C compressor.
- \*\*\* Install fuse assemblies at or as near to the battery as possible.



www.vintageair.com

# Gen 5 Super Wiring Instructions

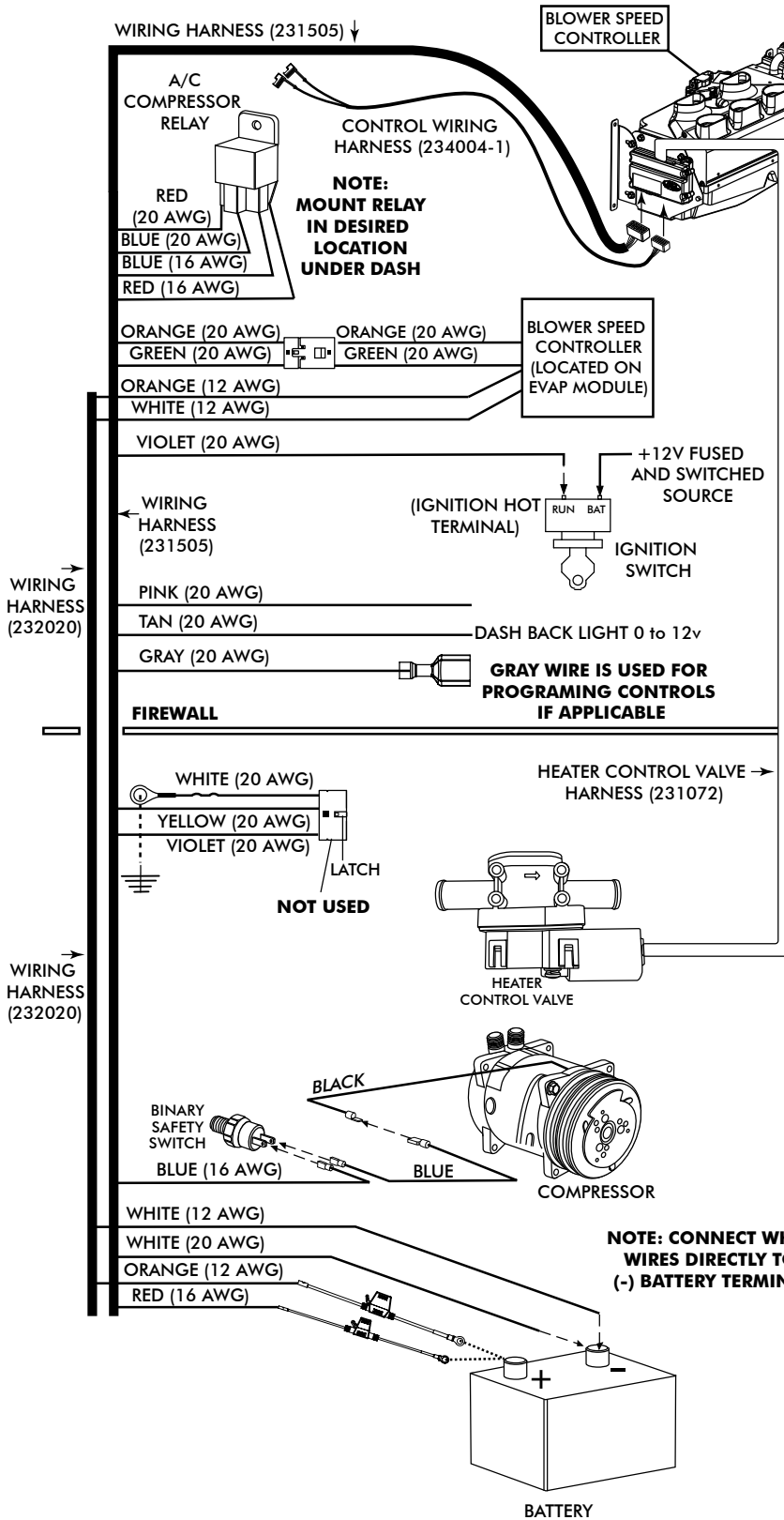

**Ignition Switch:**  
Using provided butt splice (PN 226004), connect the 20 AWG violet wire to a 5A fused and switched 12V source such as Key On.

**Wide Open Throttle Switch (Optional):**  
If a wide open throttle switch is required, connect the 20 AWG pink wire to a normally open switch that, when closed, connects a fused and switched 12V source to the pink wire. See Gen 5 wiring diagram for an example.

**Dash Light (Optional):**  
If using a Vintage Air control panel with back light, connect the 20 AWG tan wire to the vehicle's dash back light 0-12V using provided butt splice (PN 226004).

**Binary/Trinary & Compressor:**  
*Binary Switch:* Terminate provided insulated female terminal (PN 23172-VUW) to the blue 16 AWG wire. Connect as shown.  
*Trinary Switch:* Connect according to trinary switch wiring diagram.

**Battery Connections:**  
*ECU Ground:* Terminate provided ring terminal (PN 226110) to 20 AWG white wire from the 231505 wire assembly and install at battery.  
*ECU PWR:* Terminate provided fuse assembly with black leads (PN 233012) to the 16 AWG red wire from the 231505 wire assembly. Install provided 10A Red Mini Fuse (PN 226118). Install at battery.  
*Blower Speed Controller (BSC) Ground:* Terminate provided ring terminal (PN 226111) to 12 AWG white wire from the 232020 wire assembly and install at battery.  
*Blower Speed Controller (BSC) PWR:* Terminate provided fuse assembly with orange leads (PN 233008) to the 12 AWG orange wire from the 232020 wire assembly. Install provided 30A Green ATO/ATC Fuse (PN 226125). Install at battery.



www.vintageair.com

## Operation of Controls

On systems with three lever/knob controls, the temperature control toggles between heat and A/C operations. To activate A/C, move the temperature lever/knob all the way to cold and then back it off to the desired vent temperature. For heat operation, move the temperature lever/knob all the way to hot and then adjust to the desired vent temperature. The blower will momentarily change speed, each time you toggle between operations, to indicate the change. **NOTE: For proper control panel function, refer to the control panel instructions for calibration procedure.**

### Blower Speed

This lever/knob controls blower speed, from OFF to HI.

### Mode Control

This lever/knob controls the mode positions, from DASH to FLOOR to DEFROST, with a blend in between.

### Temperature Control

This lever/knob controls the temperature, from HOT to COLD.

Blower Speed

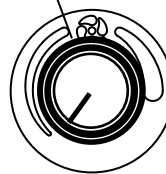

Mode Control

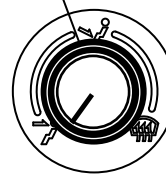

Temperature Control

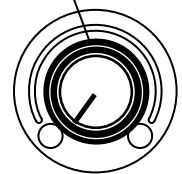

## A/C Operation

### Blower Speed

Adjust to desired speed.

### Mode Control

Adjust to desired mode position (DASH position recommended).

### Temperature Control

For A/C operation, adjust to coldest position to engage compressor (Adjust between HOT and COLD to reach desired temperature).

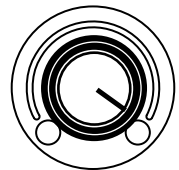
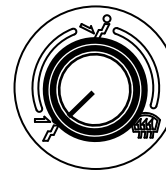
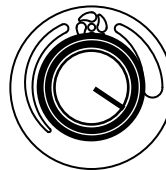

## Heat Operation

### Blower Speed

Adjust to desired speed.

### Mode Control

Adjust to desired mode position (FLOOR position recommended).

### Temperature Control

For maximum heating, adjust to hottest position (Adjust between HOT and COLD to reach desired temperature).

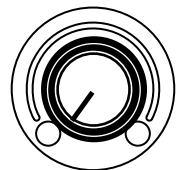
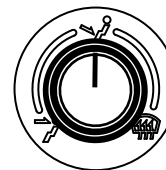
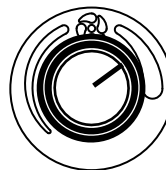

## Defrost/De-fog Operation

### Blower Speed

Adjust to desired speed.

### Temperature Control

Adjust to desired temperature.

### Mode Control

Adjust to DEFROST position for maximum defrost, or between FLOOR and DEFROST positions for a bi-level blend (Compressor is automatically engaged).

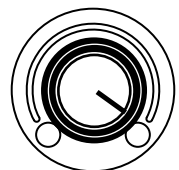



www.vintageair.com

# Troubleshooting Guide

This printed troubleshooting guide is our basic guide that covers common installation problems. To see our advanced diagnostics and troubleshooting guide, please refer to the following page for instructions on how to download the complete guide.

**WARNING: While troubleshooting the system, never probe connector terminals from the front mating side, only back probe.**

**WARNING: While troubleshooting the system, never use automotive check lights.**

Symptom	Condition	Checks	Actions	Notes
1. Blower stays on high speed with ignition on.	No other functions work.	Check for damaged pins or wires in the control panel wire assembly and mating header at ECU.	If found damaged, replace wire assembly or ECU.	If fuse continues to blow, there is a serious problem in the wiring. Check all wiring and ensure the wire is not damaged and shorting out along its route.
	All other functions work.	Check for a bad ECU GND. Check for damaged pins or wires in the control panel wire assembly and mating header at ECU. Check if Blower power fuse is blown. Check for a bad ECU GND.	If found damaged, replace wire assembly or ECU. Replace fuse. Repair connection.	
2. Compressor will not turn on (All other functions work).	System is not charged.	System must be charged for compressor to engage.	Charge system.	<b>Danger: Never bypass safety switch with engine running. Serious injury can result.</b>
	System is charged.	Check for faulty A/C potentiometer or associated wiring (not applicable to 3-pot controls). Check for disconnected or faulty thermistor.	Check continuity to ground on white control head wire. Check for 5V on red control head wire. Check 2-pin connector at ECU housing.	To check for proper pot function, check voltage at white/red wire. Voltage should be between 0V and 5V, and will vary with pot lever position. Disconnected or faulty thermistor will cause compressor to be disabled.
	Compressor will not turn off (All other functions work).	Check for faulty A/C potentiometer or associated wiring.	Repair or replace pot/control wiring.	Red wire at A/C pot should have approximately 5V with ignition on. White wire will have continuity to chassis ground. White/Red wire should vary between 0V and 5V when lever is moved up or down.
3. Compressor will not turn off (All other functions work).	System is charged.	Check for faulty A/C relay.	Replace relay.	



www.vintageair.com

# Troubleshooting Guide (Cont.)

Symptom	Condition	Checks	Actions	Notes
4. System will not turn on, or runs intermittently.	Works when engine is not running; shuts off when engine is started	Noise interference from either ignition or alternator.	Install capacitors on ignition coil and alternator. Ensure good ground at all points. Relocate coil and associated wiring away from ECU and ECU wiring. Check for burned or loose plug wires.	Ignition noise (radiated or conducted) will cause the system to shut down due to high voltage spikes. If this is suspected, check with a quality oscilloscope. Spikes greater than 16V will shut down the ECU. Install a radio capacitor at the positive post of the ignition coil (see radio capacitor installation bulletin). A faulty alternator or worn out battery can also result in this condition.
	Will not turn on under any conditions.	Verify connections on power lead, ignition lead, and both white ground wires.	Check for power at ECU, and confirm ignition is being applied to ECU properly.	
		Verify battery voltage is greater than 10 volts and less than 16 while engine is running.	Verify proper meter function by checking the condition of a known good battery.	
		Check for damaged mode switch or potentiometer and associated wiring.		
5. Loss of mode door function.	No mode change at all.	Check for at least 12V at circuit breaker.	Ensure all system grounds and power connections are clean and tight.	System shuts off blower at 10V. Poor connections or weak battery can cause shutdown at up to 11V.
	Battery voltage is at least 12V.	Check for faulty battery or alternator.	Charge battery.	
6. Blower turns on and off rapidly.	Battery voltage is less than 12V.	Check for damaged switch or pot and associated wiring.	Repair or replace.	
	Erratic functions of blower, mode, temp, etc.			

## Advanced Diagnostics and Troubleshooting Guide

If after referencing the Troubleshooting Guide, the issue is not resolved, move to The Advanced Diagnostics and Troubleshooting Guide that covers the following:

- ECU Diagnostics Codes
  1. ECU Blink Sequence
  2. Firmware Version Number
  3. ECU Model Number
  4. ECU Start-Up Blink Sequence
  5. Diagnostic Codes
- Complete Advanced Troubleshooting Guidelines

Access the latest version of the Advanced Diagnostics and Troubleshooting Guide by scanning the following QR code on your mobile device:



You can also access the guide by typing the following address into your web browser:

[https://www.vintageair.com/instructions\\_pdf/905000.pdf](https://www.vintageair.com/instructions_pdf/905000.pdf)



www.vintageair.com

## Packing List: Evaporator Kit (681000)

No.	Qty.	Part No.	Description
1.	1	681111	Super Gen 5 with Defrost Sub Case
2.	18'	06250-VUE	Duct Hose, 2 1/2"
3.	1	235000	Wiring Kit, Gen 5 Universal
4.	1	633814	Defrost Duct Kit, Universal 2 1/2"
5.	1	637100	Installation Kit

Checked By: \_\_\_\_\_

Packed By: \_\_\_\_\_

Date: \_\_\_\_\_

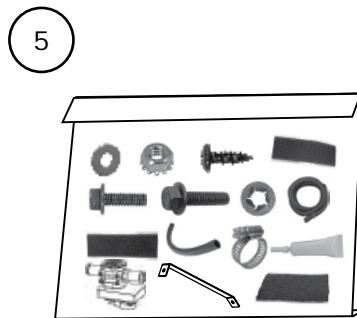
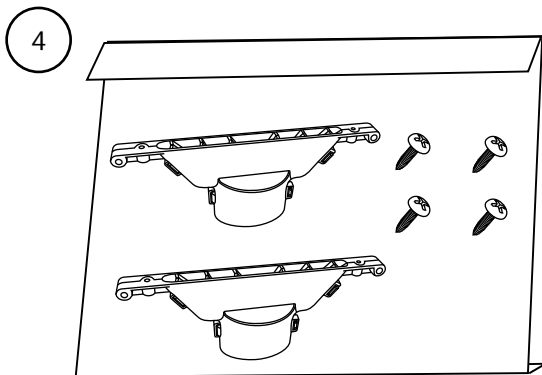
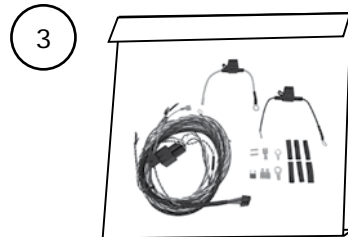
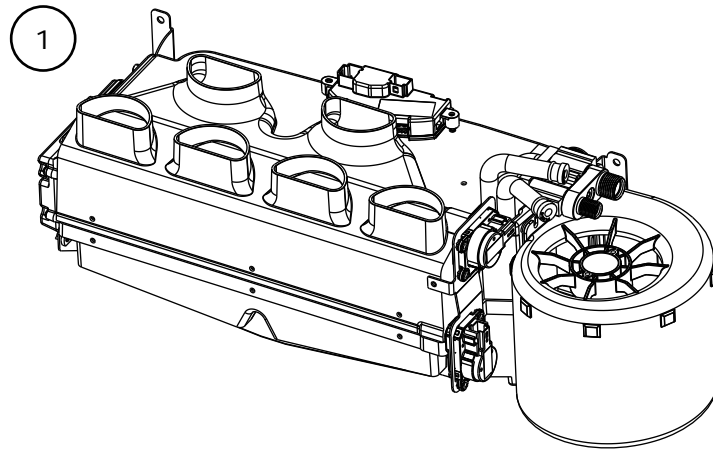

**NOTE: Images may not depict actual parts and quantities.  
Refer to packing list for actual parts and quantities.**