

**POWSTON**

**PE-18  
MINI EXCAVATOR**

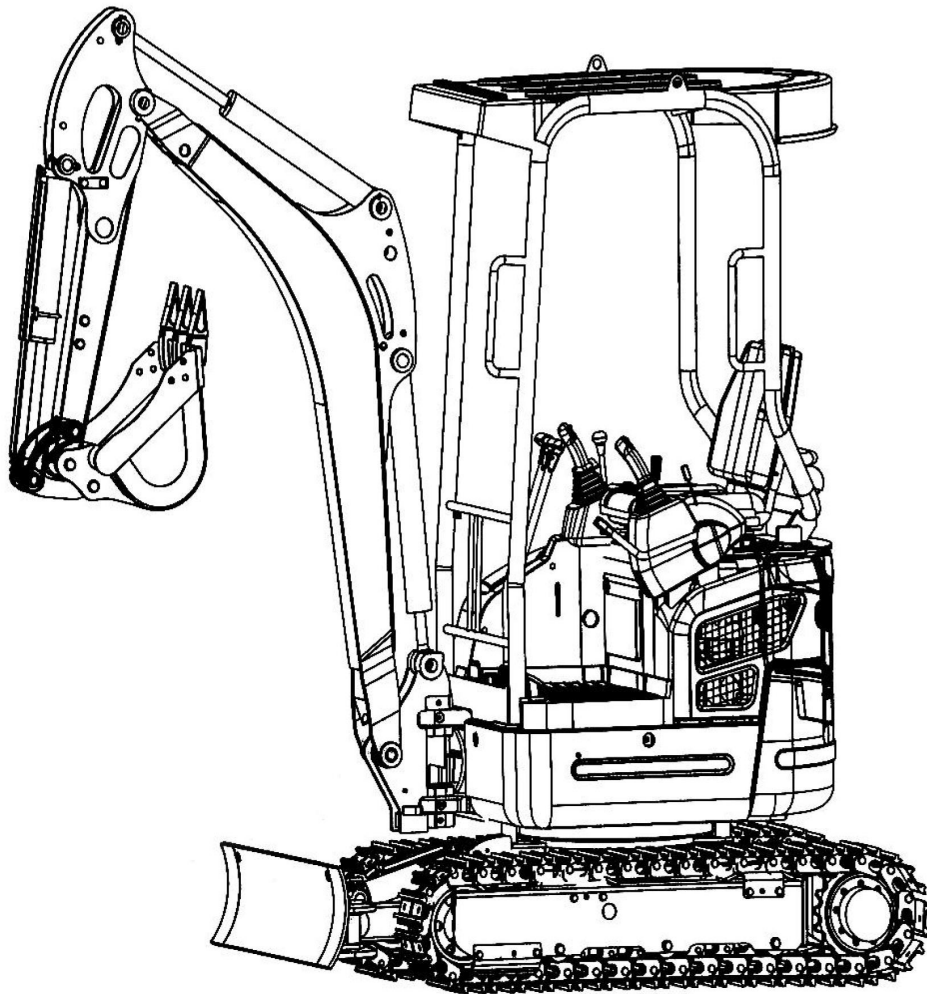

**SHANDONG POWSTON MACHINERY CO.,LTD**

Address: Nanzhang Street, Rencheng District, Jining City, Shandong Province

# Symbols for Operating Devices

For the convenience of operation and maintenance, operation devices are expressed as different symbols. Please understand the following symbols adequately to avoid maloperation

---

 Bucket dumping

---

 Boom falling

---

 Go forward

---

 Swing towards the left

---

 Arm drawing back

---

 Dozer blade falling

---

 Engine low-speed revolving

---

 Wheel track enlarging

---

 Locked

---

 Fuel (light oil )

---

 Battery warning charging

---

 Horn

---

 Working light

---

 Bucket drawing

---

 Boom lifting

---

 Back off

---

 Swing towards the right

---

 Arm push out

---

 Dozer blade lifting

---

 Engine high-speed revolving

---

 Wheel track shrinking

---

 Unlocked

---

 Working oil

---

 Engine oil pressure

---

 Engine warming up

---

 Engine idle running

---

**⚠ To insure working safely**

Comply with local laws .....	1
Fundamental matters about safety .....	1
Cautions before work .....	3
Cautions during work .....	5
Cautions after work .....	9
Cautions in maintenance .....	9
Cautions in transit .....	13
Rejectamenta disposal .....	14
Regular check .....	14
Labels and their locations .....	15
Labels maintenance .....	20

---

**About repairs and guarantee**

---

**Descriptions for each device**

---

**About the use of each device**

The use of safety devices .....	3
Stop pin .....	3
Operating handle lock rod .....	3
The use of switch and dashboard .....	4
Starting switch .....	5
Hour meter .....	5
Storage battery outage switch .....	5
Oil gauge .....	6
Simple detection device .....	6
Horn switch .....	7
Working light switch .....	7
Open/close and assembling of each part .....	7
Safety belt .....	7
The adjustment of seat .....	8
Open and close of back bonnet .....	8
Open and close of left bonnet .....	9
Fuel container cover .....	9
Instructions depositary .....	9
Fire extinguisher depositary .....	9
The use of operating handle .....	10
Throttle handle .....	11
Drive handle(left/right) .....	11
Working device handle(left/right) .....	12
Swing pedal .....	13
Wheel track adjustment or dozing .....	13
Wheel track adjustment and dozing .....	13
Accelerator pedal .....	16
Ancillary pressure supply pedal (selective purchasing part) .....	16

---

**Check before operation**

Routine check .....	17
Routine check list .....	17
Grease injection in crawler frame .....	18
Check and add coolant .....	18
Check and add fuel .....	19
Check and add engine oil .....	20
Check and add hydraulic oil .....	20
Check and clean water separator .....	21
Check and sweep radiator and oil cooler ..	21
Check and sweep storage battery, wires and engine around .....	22
Check installation site of the roof .....	22
Cautions in excavator washing .....	22

---

**Engine start and shut down**

Engine start .....	23
Start in cold season .....	23
Check after engine start .....	24
Warm running .....	24
Check each part .....	24
Cautions in overheating .....	24
Engine shut off .....	25
Fuse for emergency shut off .....	25

---

**Backhoe excavator operation**

Running-in .....	26
Start, running .....	26
Swerve .....	28
Swerve during running .....	28
Swerve during stopping .....	29
Swerve circle round .....	29
Go up and down the slope .....	30
Parking at sloping floor .....	31
Parking .....	31
Wheel track adjustment .....	32
Prohibitions .....	33
Cautions during working .....	34

---

**Truck transportation**

Loading and transportation .....	36
Unloading from the truck .....	37
Lifting .....	38
Traction .....	38

---

**Maintenance**

Rejectamenta disposal .....	39
Cautions in excavator washing .....	39

# Contents

---

Periodic check list .....	40	About fuse .....	57
Daily maintenance .....	42	Change the fuse .....	57
Grease injection for bucket pin .....	42	The location of fuse box .....	57
Grease injection for swing fulcrum pin .....	42	The capacity of fuse and circuit .....	58
Grease injection for boom root pin .....	42	Change slow-blow fuse .....	58
Grease injection for boom oil cylinder boss .....	42	Exhausting of fuel system .....	59
Grease injection for working device .....	42	Crawler adjustment .....	59
Maintenance after working per 50h .....	43	Tensioning rubber crawler .....	59
Water draining from fuel container .....	43	Loosening rubber crawler .....	60
Check storage battery diluent level .....	44	Tensioning steel crawler .....	60
Grease injection for bearing gear root .....	45	How to use rubber crawler .....	61
Maintenance after working per 100h .....	46	Change the bucket .....	61
Gear oil change for terminal drive .....	46	Disassemble the bucket .....	61
gearbox (1st after 100h, then per 500h) .....	46	Assemble the bucket .....	62
Maintenance after working per 200h .....	46	Change the bucket teeth and side teeth .....	62
Check and tensioning the fan belt .....	46	Change the bucket teeth .....	62
Check and sweep the air filter .....	47	Change the side teeth .....	63
Grease injection for bearing balls .....	47	Maintenance after long-term preservation .....	63
Check the radiator hosepipe .....	47	Preservation if long time no used .....	63
Maintenance after working per 250h .....	48	Rework after long-term .....	63
Change engine oil(1st after .....	48	preservation .....	63
50h, then per 250h) .....	48	Use in cold season .....	64
Change engine oil filter core(1st .....	49	Safeguard procedures at low temperature .....	64
after 50h, then per 250h) .....	49	Cautions after work .....	64
Change hydraulic oil return filter(1st after .....	49	Regular replacement of important parts .....	65
250h, then per 500h) .....	49		
Maintenance after working per 500h .....	50	Questions and solutions of backhoe .....	
Change fuel filter core .....	50	excavator .....	
Gear oil change for terminal drive .....	50		
gearbox (1st after 100h, then per 500h) .....	50	Cautions in using the hydraulic hammer .....	
Change hydraulic oil return filter(1st after .....	50	Assembling of hydraulic hammer .....	67
250h, then per 500h) .....	50	Cautions of hydraulic hammer in use .....	68
Maintenance after working per 1000h .....	50		
Change hydraulic oil ( change the filter .....	50	The recommend lubricating grease .....	
at the same time .....	50		
Change hydraulic pilot return filter .....	51		
Maintenance after working per 1000h or 1 year .....	52		
Change the air filter .....	52	Appendix .....	
Maintenance after working per 2000h .....	52	Dimensional drawing .....	72
Change grease of track roller and front idler .....	52	Major parameters .....	73
Check the alternator and starting motor .....	52	Consumable items .....	74
Maintenance after working per year .....	52		
Check the wires and the use of fuse .....	52		
Maintenance after working every 2 year .....	53		
Change coolant (long-acting coolant) .....	53		
Change radiator hosepipe and clamp .....	54		
Check and the use of storage battery .....	54		
Battery maintenance .....	54		
Cautions in charging .....	55		
Check the battery diluent level .....	55		
Cautions in charging when the battery .....	55		
is on machine (only in emergency) .....	55		
Start the engine use emergency wire .....	56		
Cautions in engine starting and .....	57		
battery charging .....	57		

# Preface

Thank you for purchasing OULIDE product.

In order to correctly use, simply check and repair the product, necessary descriptions are showed in this book. Please read and understand the descriptions carefully, because no supervisions about using, working, check or maintenance of the product are supplied by the manufacturer. In addition, matters not described in this book may occur due to work content and apply to relevant laws, rules, regulations and insurance conditions. After reading the descriptions, make sure properly keeping the instructions for necessary consulting at any time. If the instructions are damaged, please replace with a new one. Moreover, the product may be improved and the descriptions may inconsistent with the product, sorry for the inconvenience.



## Safety first

The cautions in this book and the symbols  are important items which may led to human injury. Make sure carefully read and strictly observe.

If the symbols  are damaged or fell off, please re-post them at specific locations.

Caution symbols

The instructions mark important matters as the following symbols.



**Danger**

Death or serious injury would be caused by offending this caution.



**Warning**

Death serious injury may be caused by offending this caution.



**Attention**

Injury may be caused by offending this caution.



**Important**

Machine would be damaged or broken down by offending this caution.

**Supplement**

This symbol means supplementary instruction.



In order to ensure working safely, please read and understand the instructions carefully before use the machine. The cautions must be observed are listed below. Symbols   
Danger  Warning  Attention Important Supplement also presented.

### Comply with local laws

Insurance floor level, work permit, guardrails, working time, etc., which enacted by the government should be obeyed under certain conditions. Reference standards and limits may also exist in some working conditions. Please obey the local requirements about the safety of underground installation and cable.

In order to work safely, the following matters should be obeyed:

### Fundamental matters about safety

1. For the sake of safe working, make sure carefully reading and understanding the instructions before use the machine.
2. If the machine is lent to other person, please detail the operation methods to him/her and let him/her carefully read and understand the instructions.

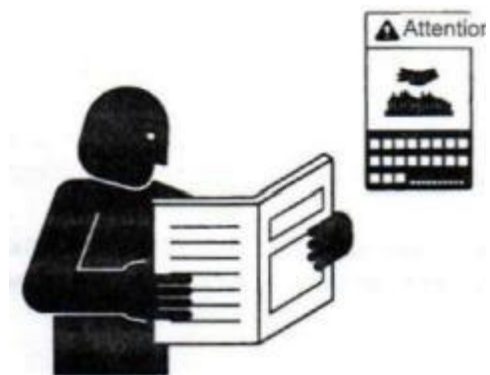

3. Fasten the seat belt all the time when working with the 4-column simple roof type machine. Otherwise, seat belt is not available.



4. Do not change 4-column simple roof. If the simple roof is damaged or bent, please replace the roof.
5. Do not disassemble 4-column simple roof and operate the machine.

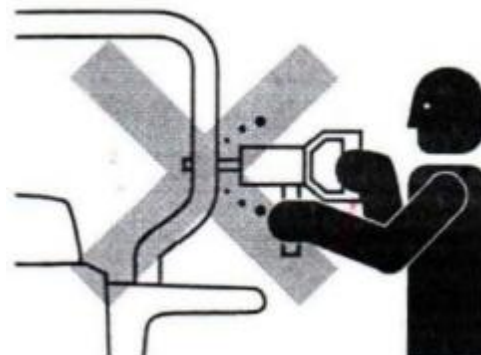



6. Please wear safety helmet, safety shoes and safety clothes when driving or maintaining the machine.

Please wear safety goggles, dust mask, isolation equipment, protective gloves and other safety materials. Ensure the safety materials are functional well.

Keep the driver seat and around clean.

If oil, grease, ice, snow and mud are attached to footboard and handrail, slipping and tripping may occur. In addition, keep the shoes from mud.



7. Prepare safety materials.

Please prepare safety materials in case of injury or fire.

First-aid kit and fire equipment should be prepared.

Contact information of emergency hospital, ambulance and fire brigade should be prepared.

Drinker, lack of sleep, pregnant woman, over fatigue and the sick are prohibited to use the machine.



---

8. Daily check

Eliminate abnormalities (oil leakage, water leakage, bolt and nut loosening, wire broken, terminal loosening, etc.)

Please use the fuel and grease of specified brand.

9. The safety shield must be assembled before use the machine.





- 
10. Shut down the engine when refueling, grease injecting, checking and adjusting.  
Fire is prohibited when refueling.  
Do not leak fuel.



- 
11. No person is permitted to pass through when the bucket is drawing up.  
12. Do not touch electric wire and obstacle when the bucket is drawing up. Electric shock may lead to fatal accidents. Please be careful.  
13. To avoid accidents, operators are prohibited to use the machine after drinking and taking medicine.

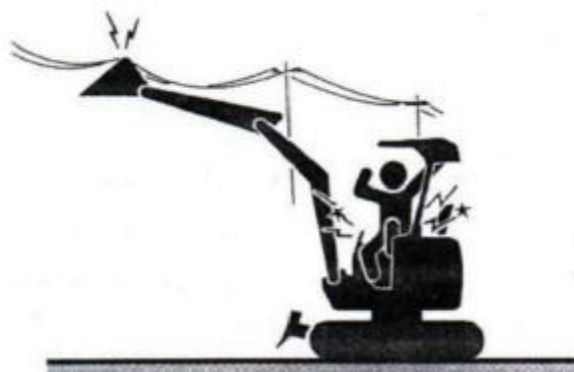

---

### Cautions before work

1. Make sure no people are around.





2. Make sure verify the following items before start the machine:

- Start the engine only when the operator is in the cab seat.
  - Make sure all the operate handles are in the default positions.
- e The exhaust pipe is backward, so make sure no people is behind the machine. Walls may be smudged and plants may be burned to death by the offgas. Therefore, safeguard procedures must be done before working.

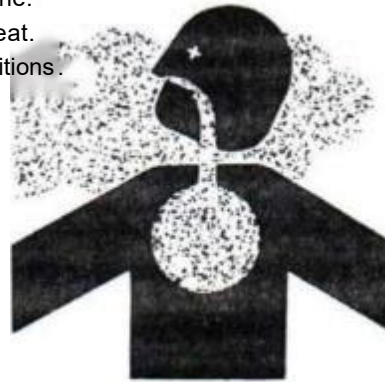

- Make sure no inflammable is around.
- Verify the bucket has touched ground or not .
- People may be poisoned when working indoor. Make sure ventilate sufficiently when work indoor.

3. In case of sliding, hold the handrail when get on or off the cab.  
Do not jump on or off the cab  
Do not get caught by the hand.rail when get on or off the cab.

4. Adjust the cab seat to a proper position if available.

5. Please verify the direction of the machine before start the engine. The dozer blade side is the front side. The machine may go the opposite direction when the drive handle is operated involuntary. Misoperation is dangerous .

6. Check the working condition of bucket, arm, boom, dozer blade, drive and rotate mechanism under situation of no people and obstacle are around in expansively place .

If abnormity appears, repair it immediately.



---

### Cautions during work

---

1. Beginner should operate slowly when using the machine .
2. Please operate correctly in the seat(do nont gaze around , jump up and down). Others except the driver are not allowed to take the machine . People are not permitted on the bucket.
3. To avoid accidents and mechanical failure, other purposes are prohibited.



- 
4. Make sure no people and obstacle are around before operating. No people is allowed to enter the operating envelope .
  5. When working condition is poor , instructor should be arranged.

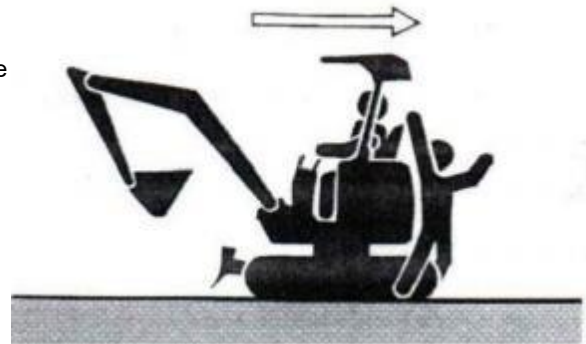

- 
6. Please verify the direction of the machine before operate the running handle. When front idler and dozer blade are behind , pulling forward the drive handle , the machine goes backward , otherwise goes forward. Operate the machine after verifying safety around.(The machine may go the opposite direction when the drive handle is operated involuntary. It is dangerous)





7. Do not steering, turn round or get through on the slope in case of turnover or sliding. Steering at flat ground.



8. Please do not turn on swing or rotate switch on the slope in case of turnover. Please levelling the ground before work if your have to work on slope. Do not work on rocky ground and soft soil. Avoid run through bulge or uneven ground in case of turnover.



9. Please put the work devices forward and the bucket 20~40 cm above the ground when running or climbing slope. In this condition, bucket can be put down to the ground immediately in case of danger and keep stable. Do not go up or down slope during swing.

Do not run on slope more than 15° in case of turnover.

10. If slip appears when go up and down soft slope, put the bucket down to the ground immediately to brake.

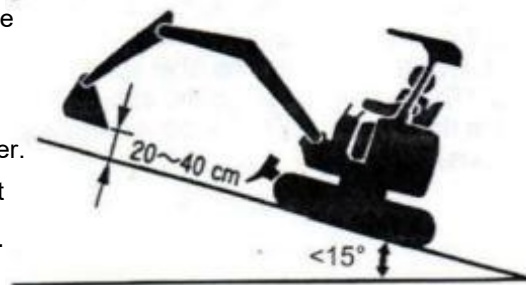



11. Keep a distance away from cliff or roadbed in case of fall down, or reinforce the pavement. Keep clear of rockfall area. It is dangerous when running after rain and make sure do not get close to cliff or roadbed.
12. Be cautious of excavating soil under the machine in case of turnover caused by ground collapse.



13. Do not excavate below cliff in case of collapse and rockfall.
14. Machine stability will decline when the work or road conditions are hostile; turnover would caused by misoperation in this condition. Get clear of the rated load of bridge and buildings when work on them; reinforce them if necessary.
15. Generally, it is liable to turnover when the machine is put transversal. Therefore, make sure not revolve the machine when heavy loaded.
16. Please be cautious when work with water or rain in case of slipping

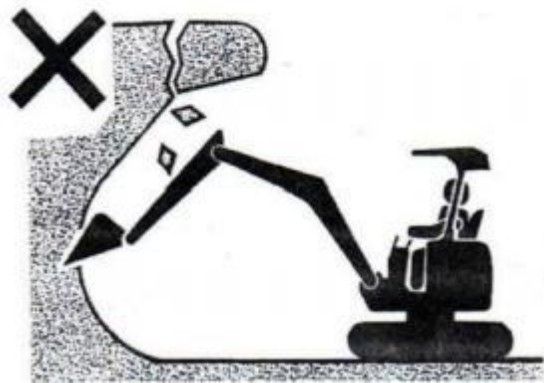

17. If wire, gas pipeline or water pipe is underground, specialist should be present and excavation should be cautious.
18. If bucket tooth get stuck in stone or other object, turnover may caused by bucket tooth pulled out. Do not drive the machine when the bucket is planted in the ground. Do not excavate when the main body of the machine is dangling.

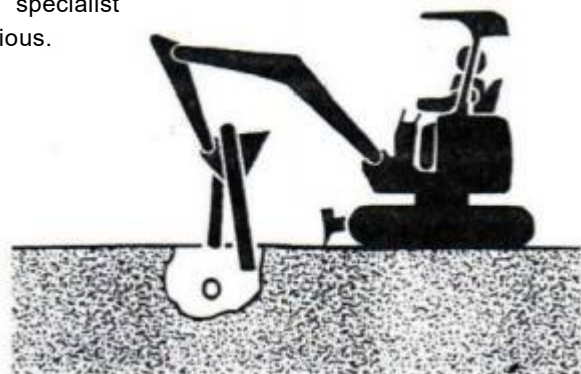



19. Keep an eye on the strength of the top, exit, passageway and floor during indoor working.
20. Cautions in wheel track adjustment  
Wheel track can be adjusted hydraulically from 990~ 1240 mm

- Shrink wheel track when passing through flat and narrow place.
- Enlarge wheel track to maximum in other conditions in case of turnover.



- Be cautious of road width and make sure the machine can get through if dozer blade is assembled extended board.

21. The legs may get stuck by boom and oil cylinder during swing operation. It is absolute prohibited put the legs out of machine.

---

## 22. Goods lifting

- The maximal lift weight is 588N (60kgf). Make sure goods weight is less than the maximal lift weight.
- The machine can not replace the crane in lifting work.





### Cautions after work

---

1. Park the machine in flat place. If you have to park it on the slope, put bucket teeth into the ground and apply the necessary braking measures.
2. When you leave the cab seat, please
  - put the bucket down to the ground
  - o lock the operating handle
  - shut down the engine and pull out the key
3. Put on shield after the high-temperature silencer cools down in case of fire.

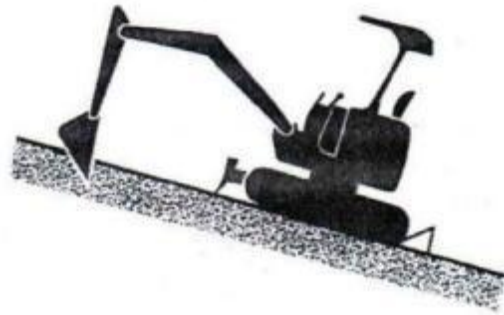

### Cautions in maintenance

---

1. Check and sweep the working devices and other parts after shut down the engine. It is dangerous to maintain the machine when the engine is working.  
Please maintain the machine in a safe, flat and firm place.
2. Hold the warning sign "Maintaining" on obvious place and around. Keep clear of irrelevant people.





3. The fuel and battery have the risk to fire, so fire precaution measures should be prepared in maintenance and refueling.

- Wash components with fire retardant oil.
- Put off dangerous fire around
- Fire extinguisher is available.
- Use blast-proof light when checking fuel, engine oil and battery diluent.
- Keep off inflammable during grinding and welding.



4. Fire and explosion may caused by battery gas.

- Make sure the battery is keep off fire.
- Do not shorten out the two poles with metal when check the battery. It is dangerous.

Do not charge frozen battery in case of explosion. If the battery is frozen, make the temperature up to over 15°C .

Blindness and burn may caused be by battery diluent (dilute sulphuric acid). Clean with water if skin or clothes are attached the diluent. Wash with water then go to hospital if eyes are attached the diluent.

---



5. Do not use and charge the battery when battery diluent at LOWER level(minimum level).  
Battery life would be shortened or explosion may be cause when using the battery with battery diluent under the LOWER level.  
Add water to the range between UPPER level and LOWER level(if the battery can add water).
6. Ventilate sufficiently when maintaining indoor or enclosed space , especially emissions are exhausting and deal with fuel, oil and coating.
7. Please use standard tools in maintenance. Low efficiency and injury may be caused by un-standard tools.
8. Engine (and around)maintenance and check after the cover is supported well.
9. Disassemble the hydraulic system in off-working state and put the bucket and dozer blade down to the ground then shut down the engine. Hydraulic oil and lubricating oil remain high-temperature when the work just finishes . Operator may get burned in this condition .  
High pressure hydraulic oil and ejected parts may cause injury. Disassemble hydraulic system slowly and keep away from front body after temperature and residual pressure falls.  
Be cautious and keep away form the leak position if high pressure fuel and oil leak. High pressure fuel and oil is dangerous.





10. Wear protective glasses and use assistant tools like strawboard to look for leaked pinhole. Serious anaphylaxis may appear if oil intrude into skin. See a doctor in this condition.

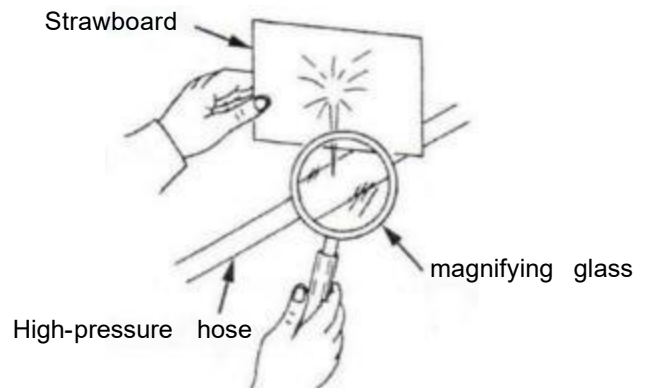

11. Check, add or change coolant after the engine cool completely in case of burn by steam or hot water.



12. Turn the start switch to "Off" when welding directly on the machine. Welding causes spark; please do not put anything between the weld and ground causing electrify oil cylinder or sealed bearing and defective condition.

13. In order to maintenance and check, no person is permitted to get to the bottom of the machine by uplifting the machine depending on work device. If necessary, cushion block and backbone must be put under the machine to ensure safety and avoid falling down. Operating handles should be locked at the same time.
14. Short-circuit or malfunction would be caused by soaking. Please keep the battery, sensors and electrical components away from water.

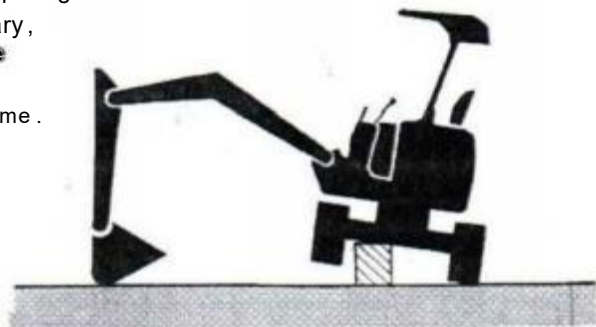



## Cautions in transit

- Caution: use truck to transport the machine.
1. Obey laws related to transportation.
  2. Park the truck in flat ground and brake all wheels when loading and unloading. The loading and unloading platform should have enough strength and width.

Use a strong plate (the plate length should be more than 4 times than the height of the truck carriage) to load or unload if necessary. Keep the plate off of soil and make it non-skid. Load and unload slowly.

Orientate the work device to the driving direction. Make the arm perpendicular to the plate or drawing back slightly. Keep a distance of 20 ~ 40 cm from the bucket to the plate.

Take a support or block to avoid excessive bend. Do not load and unload the excavator with a plate in rain in case of slipping and dangerous conditions.

In case of falling down or turnover, do not lift the excavator by operating the boom and the arm when loading or unloading. In addition, do not change direction on the plate.

3. Make the bucket and dozer blade touch the bottom of truck carriage and fix them after the excavator is moved to the truck carriage. Then brake the crawler and fix the main body of the excavator to the truck by wire rope. Sometimes, bucket should be put in carriage baffle and fix it according to the truck type.
4. Do not start, stop and swerve suddenly during transporting in case of excavator moving and unbalance.  
(Details refer to chapter "Truck transportation")

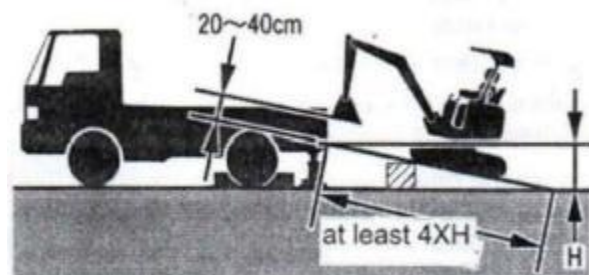



## Rejectamenta disposal

---

Environment would be polluted by the castoff. Environmental pollution behaviors would be punished according to laws . So

do not throw away and incinerate castoff at random .

Dispose the castoff properly:

- \* Gather effluent exhausted from the machine to a container .
- \* Do not exhaust the effluent to the ground or pour into rivers , lakes or seas .
- \* Refer to the dealer or related organization to throw away or incinerate castoff(waste oil , fuel , coolant , antifreeze fluid , solvent , filter , battery , rubber or other waste material)



## Regular check

---

Make sure regular check to ensure safety. The time mentioned in the instructions is hour meter time, which is taken as the standard in regular check.

★Main cautions are listed above. The following symbols are also used in the text:

Danger AWarningA Attention ImportantSupplement

Please carefully read and obey the the instructions.



Labels and their locations

Labels related to safety are posted on the machine. Please operate the machine on the basis of adequate understanding. Please read carefully.

(1)Part NO.W15-75-00160(Two sides)



Be cautious of strike

Keep off

(2)Part NO.W15-75-00420(Two sides)

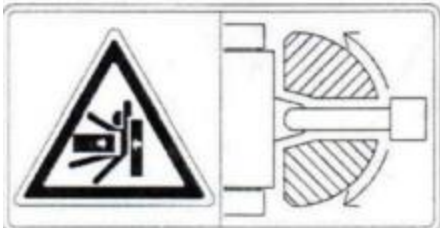

Be cautious of clamping

Keep off of rotation range

(3)Part NO.W15-75-00270 (Two sides)

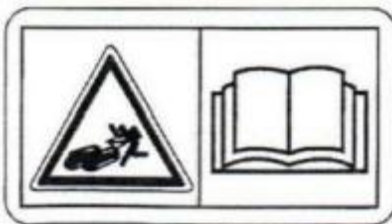

Be cautious of the flying bolt

Make sure thoroughly read the instructions

(4)Part NO.W15-75-00250



Operate cable after thoroughly read the instructions. Be cautious of electric shock

(5)Part NO.W15-75-00150(Two sides)

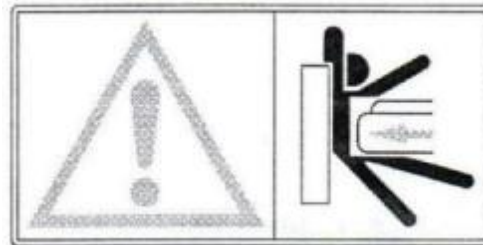

Warning

Be cautious of clamping

(6)Part NO.W15-75-00480

<b>Warning</b>	Fasten the seat belt when working with machine installed safeframe in case of death cased by turnove.	
<b>Attention</b>	Replace the safeframe directly when it is damaged rather than repair it.	

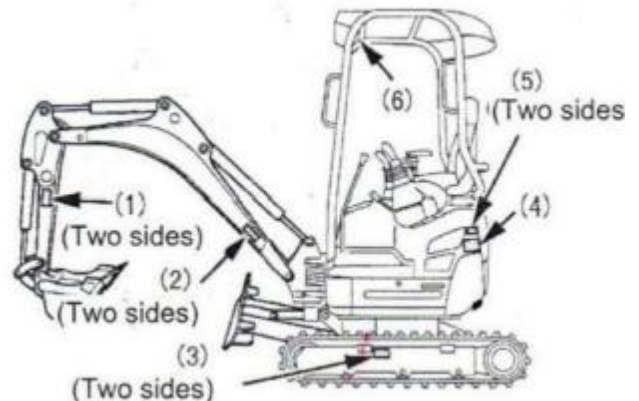

(1) Part NO.W15-75-00210

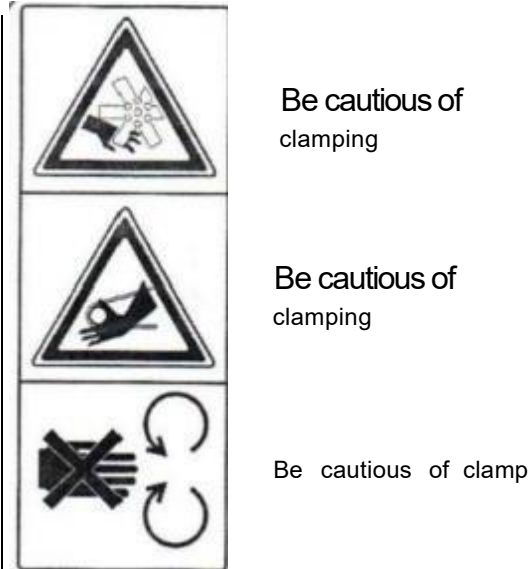

(2)Part NO.W15-75-00220

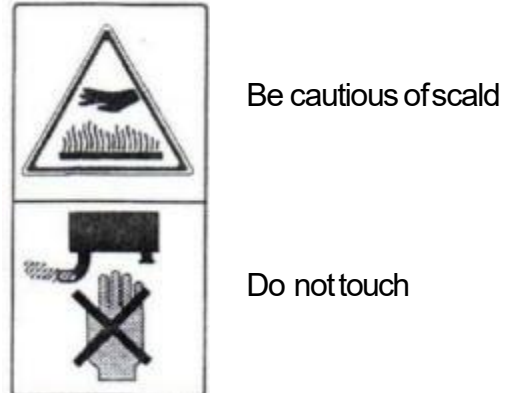

(3)Part NO.W15-75-00510

 <b>Attention</b>
<ol style="list-style-type: none"> <li>1. Make sure no bolts are loosening or deformation. If abnormality appears, tighten the bolts with torque stated in instructions.</li> <li>2. Do not disassemble the roof. If necessary, assemble with suited bolts and tighten them with stated torque according to torque stated in instructions.</li> <li>3. The tightening torque of M14 bolt and nut 123.6~ 147.1N·m (12.6 ~ 15.0kgf·m)</li> </ol>

(4)Part NO.W15-75-00230



Be cautious of scald      Do not open

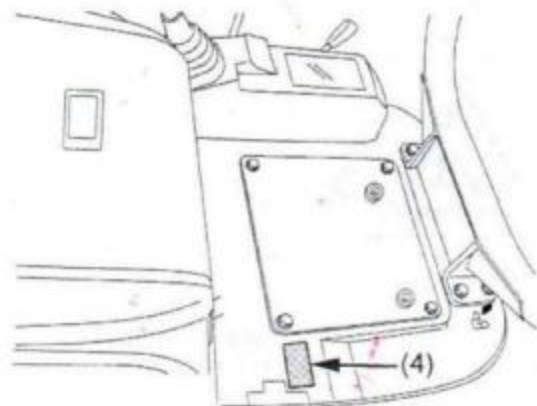
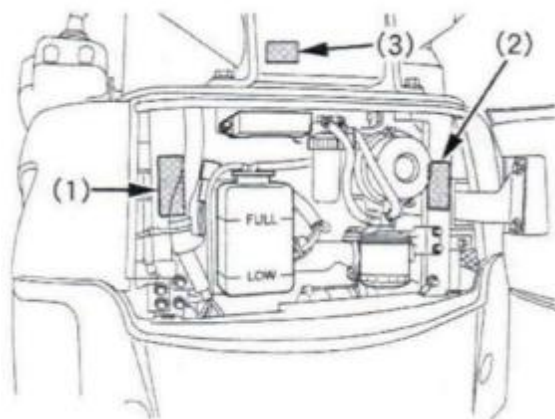





(1)Part NO.W15-75-00260

	<b>Attention</b>
<p>Lock the machine in transportation . Otherwise human injury may be caused by machine rotation.</p>	

(2) Part NO.W15-75-00130

	<b>Attention</b>
<p>Disassemble the hydraulic device follow accord to the following steps: 1) Reduce engine rotate speed, and put the bucket down to the ground. 2) Stop the engine, and move the operating handle omnibearingly . 3) Wait for at least 10 min to release the residual stress in hydraulic tube. Be cautious of bun by ejected oil when loosening the tube.</p>	

(3)Part NO.W15-75-00140

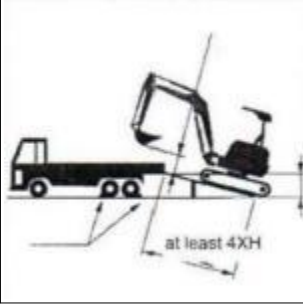
	<b>Warn</b>
	<p>Use a platform when loading a unloading. Obey the following items when using a plate</p> <ol style="list-style-type: none"> <li>1. Load and unload follow the left figure(the plate length should be more than 4 times than the height of the truck carriage in case of turnover)</li> <li>2. Stop the truck when carry out the above operations.</li> <li>3. Do not change the direction on The plate</li> <li>4. Close the switch is automatic Idling function if available. Keep off from the machine in case Of turnover in loading and Unloading.</li> </ol>

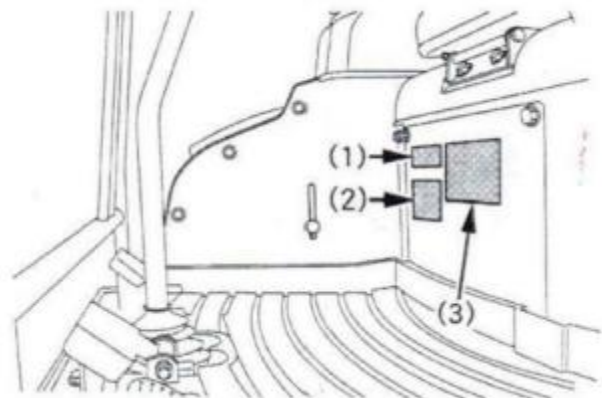



(1) Part NO. W15-75-00110

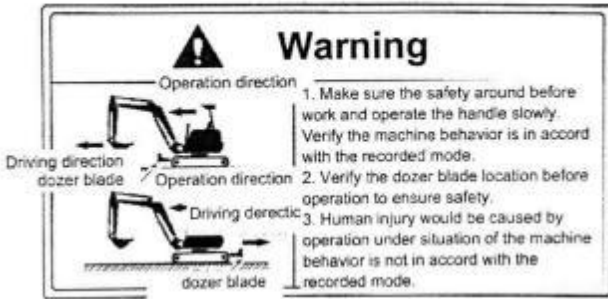

(2)Part NO.W15-75-00280

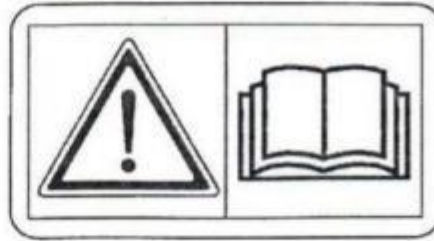

**Warning** Make sure thoroughly read the instructions

(4) Part NO.W15-75-00105



Explosion No fire

(5)Part NO.W15-75-00100



Diesel, fuel

(3)Part NO.W15-75-00180



**Be cautious of suddenly start** When leaving, make sure put the bucket down to the ground and lock it, and shut off the engine.

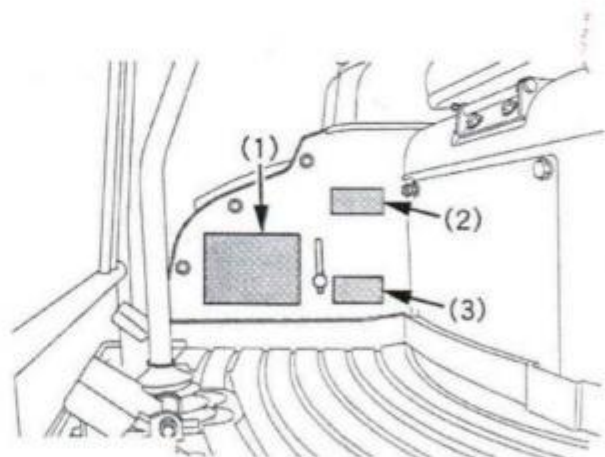
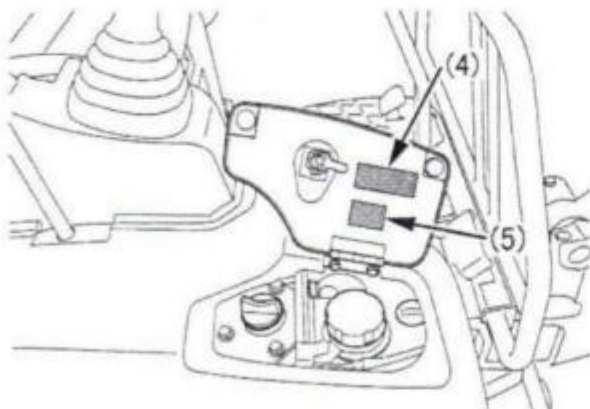

(1)Part NO.W15-75-00190

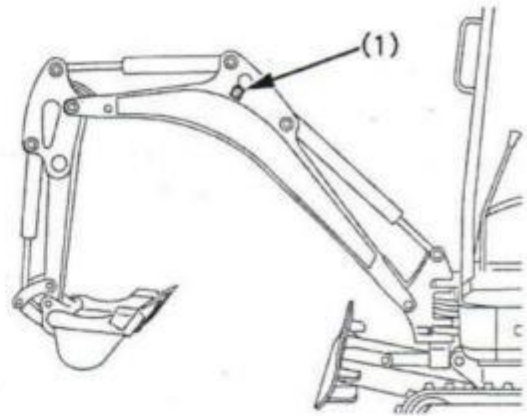

(2)Part NO.W15-75-00240



Be cautious of electric shock Keep safe distance

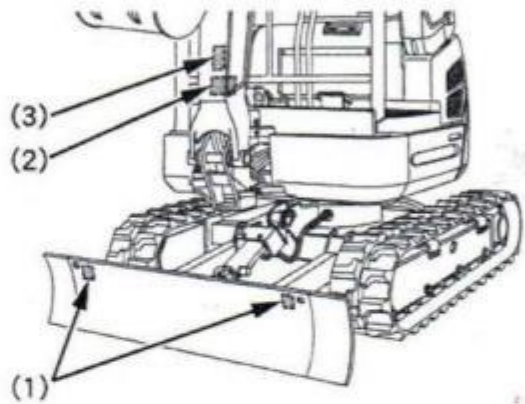

(3)Part NO.W15-75-00170



Be cautious of clamping foot

Make sure thoroughly read the instructions



(4)Part NO.W15-75-00520





### **Labels maintenance**

---

1. Keep clean of the labels. Make sure not be damaged.  
If the any label is soiled, wash it with suds and clean it with soft fabric.
2. Do not wash the labels directly with high-pressure washer in case of labels falling off.
3. Refer to the dealer and re-post the labels at the native location when labels are damaged or lost.
4. Sweep the label location thoroughly before post the new label. Make sure the location is dry.
5. If the part is a new replaced one, re-post the label at the same time and at the same location.

## About repairs and guarantee

---

Refer to the dealer or manufacturer if malfunction and unknown appears or it need repair.

Inform the following information when look for help:

- (1) Type name and NO., underpan NO., production NO.
- (2) Engine name and NO.

In addition, refer to the local dealer when order components or parts if required.



### Warning

\* It is dangerous to refit the machine. Please do not refit the machine. Problems may be caused by refit which is not in accord with the instructions or correct purpose. The machine is not guaranteed by the manufacturer if refit took place.

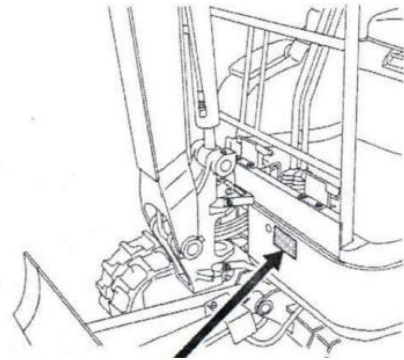

Underpan NO.

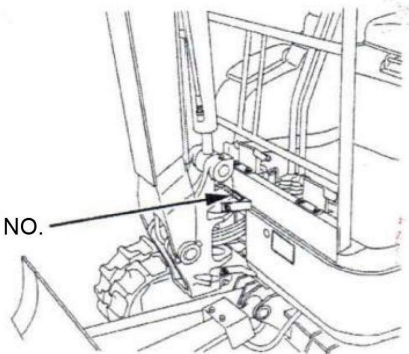

Engine NO.

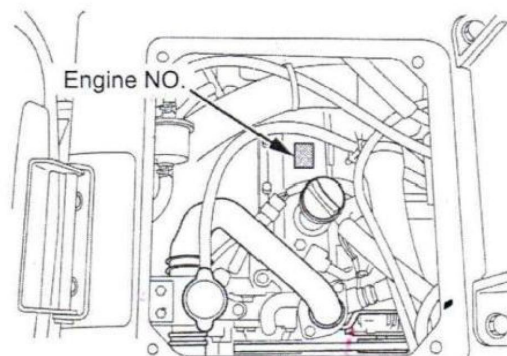

## Descriptions for each device

---

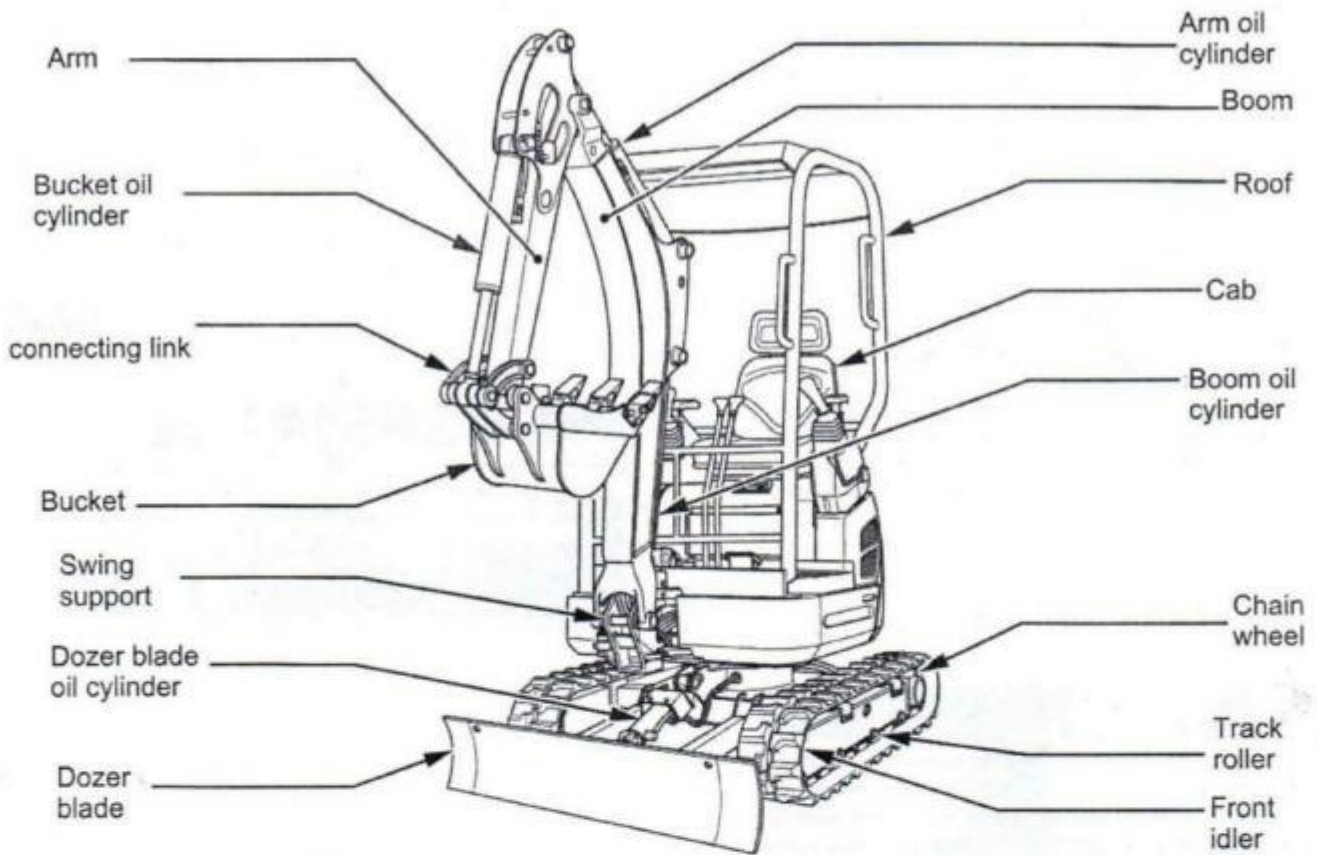

# About the use of each device

## The use of safety devices

### Stop pin

This part is used to lock the rotating frame. Unlock the frame by pulling up the stop in at "unlocked " position.

### Important

- \* Lock the rotating frame by pull the rotating frame parallel with the crawler frame.

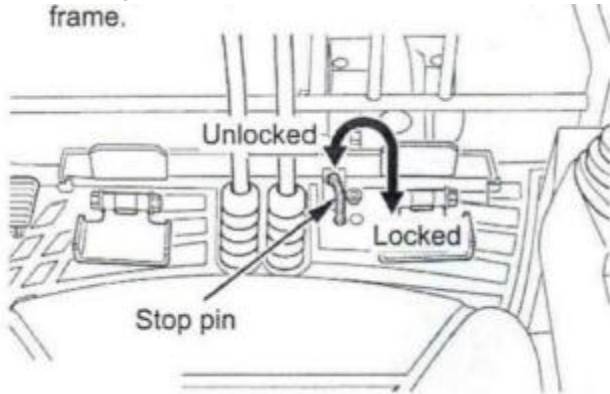

### Operating handle lock rod



### Attention

- \* **When leaving or stoping, make sure put the bucket** down to the ground and lock it. Bucket falling is dangerous. Get off the cab after the lock rod is at locked position and pluck out the key.

The lock rod is used to lock and unlock the work device operating handle and drive handle.

### Supplement

- \* Work device remains stationary when operating handle is locked. Operate swing pedal and dozer blade operating handle at this time, the desired behaviors would achieved.

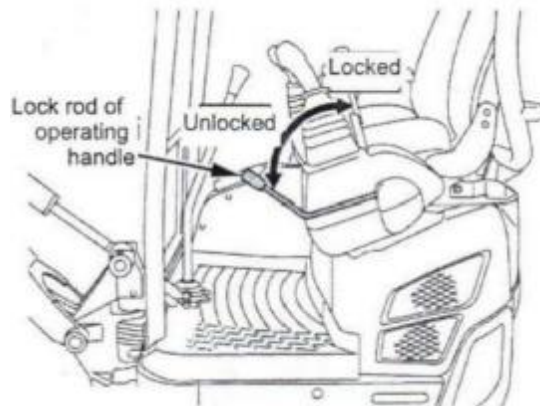

### Supplement

- \* Work device can not move by pulling up the operating handle lock rod . Pull up operating handle lock rod completely when get on or off the cab. When leave, make sure put the bucket down to the ground and shut off the engine.

# About the use of each device

## The use of switch and dashboard

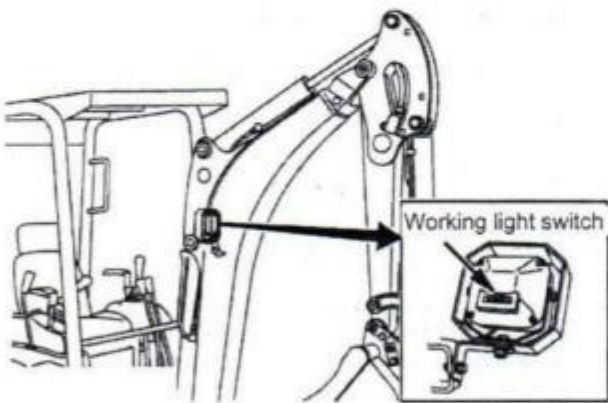
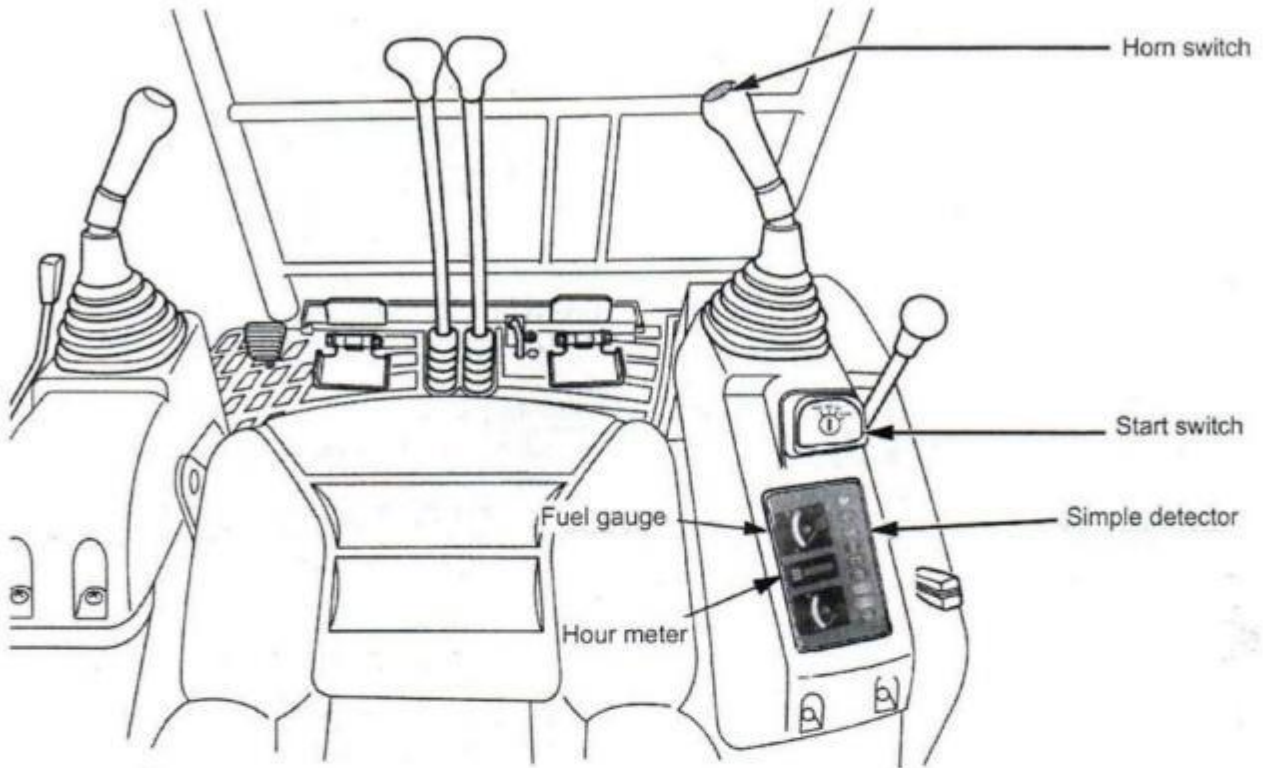

	Reference Page
(1) Honswitch .....	7
(2) Startswitch .....	5
(3) Simple detector .....	6
(4) Fuelgauge .....	6
(5) Hourmeter .....	5
(6) Working lightswitch .....	7

## About the use of each device

Starting switch

- “Off”

Insert the key at "Off"

- “ON”  
Turn the key to the right to "ON" and all circuits is powered on. The machine preheats and meter display works at this time. (Preheat time need at least 3 s.)

In order to check indicator light filament, indicator light turn on for about 1s.

- “START”(起动)

Continue turning the key to right to "START" and the engine starts. Release the key and it return to "ON" automatically. Release the key after the engine starts.

### Important

- \* Make sure put the operating handle lock rod to "Locked" position when start the engine . Otherwise the engine would not start.

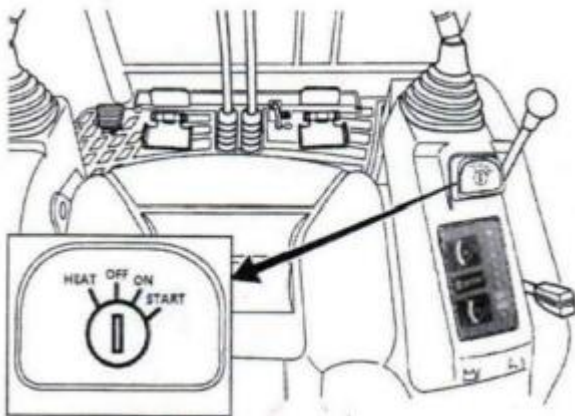

### Important

- \* If the the key put in metal key chain, which obstruct signal transmission between the key and the switch, causing the engine unable to start normally.

Hour meter

It shows the accumulated running time.

- \* Count method of the hour meter

The number increase about 1 after running 1 hour. It is a electronic hour meter. Even if the engine shut off, the hour meter continue counts so long as the key at position "ON".

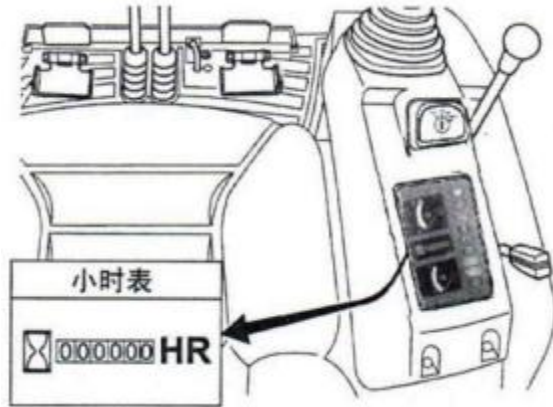

### Supplement

- \* Vapour may exist inside the hour meter, which do not mean malfunction. The hour meter would be clear after vapour evaporates.

Storage battery outage switch

Open the cover, battery outage switch can be seen.

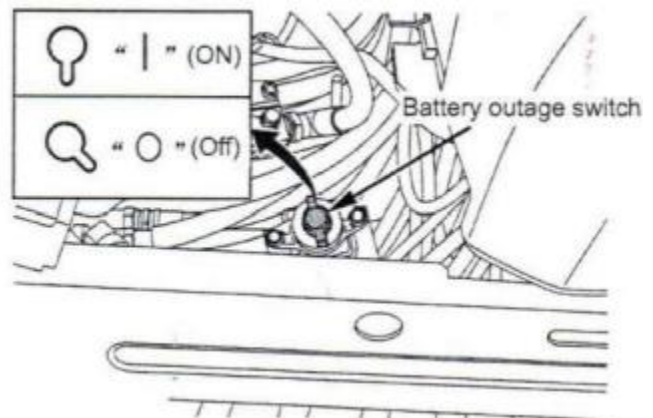

### Supplement

- \* Turn on the battery outage switch and turn the start key to "ON" at the same time, then xirAtits in maarad An
- \* The battery can not be charged if turn off the batterv outage switch.
- \* Most functions can not be achieved if turn off the battery outage switch and turn the start kev to "OFF".
- \* Do not turn off the battery outage switch when start key is turned to "ON" or the engine start is starting. If not, the effect of battery outage switch mav decline or malfunction occurs.

# About the use of each device

Oil gauge

 <b>Attention</b>
<p>* Make sure shut off the engine when refuel.            * Never close to fire. Fire disaster would be caused by negligence.</p>

Turn the start key to "ON" and fuel gauge shows the remaining oil in the fuel container.

**Important**

\*Please refuel as soon as possible when the pointer approach "E".. If not, the engine may shut off by oil supply outage when the machine inclines.

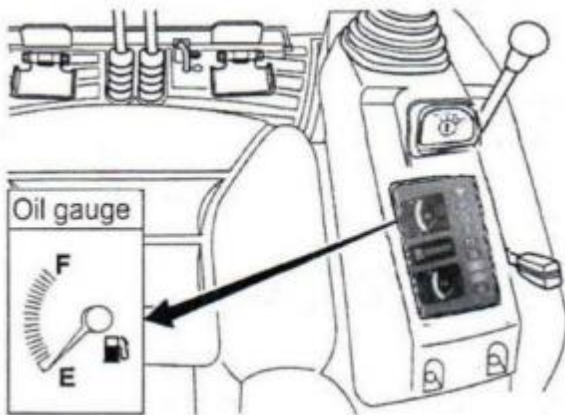

Simple detection device

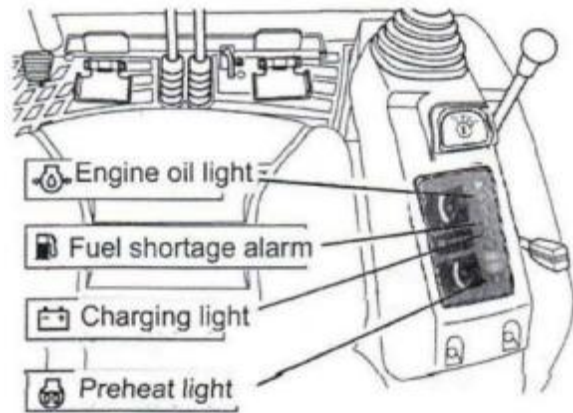

白 Charging light

When the engine is running, charging light turns on under situation of abnormality appears in charging system. When the engine is shut off, charging light turns on under situation of the start key turning to "ON", and turn off after the engine starts.

Fuel shortage alarm

Fuel shortage alarm turns on in the following condition

Remainder fuel	about 2L
----------------	----------

四 Preheat light

Preheat light turns on when the start key at "ON", and turns off after preheating overs.(about 5s)

心 Engine oil light

When the engine is running, engine oil light turns on under situation of abnormality appears in lubrication system. Engine oil light turns on under situation of the start key at "ON", and turn off after the engine shut off. Check engine oil remainder and stop the engine if the light turns on during engine running.

**Important**

\* Do not conduct daily check depend on simple detector.  
 (Refer to Chapter "Daily check list")

# About the use of each device

## Horn switch

The horn blows when press down the horn switch and the start key at "ON".

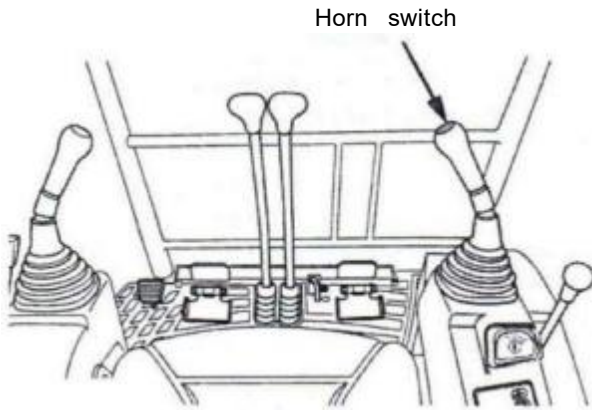

Open/close and assembling of each part

## Safety belt



## Warning

- \* Fasten the seat belt all the time when working with the 4-column simple roof type machine. Otherwise, seat belt is not available.
- \* Adjust the seat to suitable position, and fasten the seat belt.

## Working light switch

Working light turns on when the switch turns to "ON" and the start key at "ON".

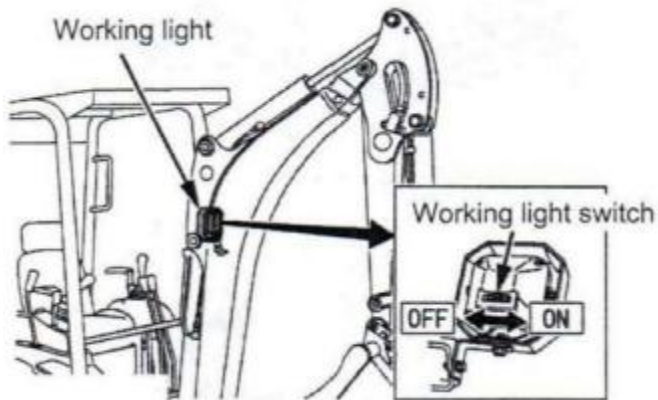

## Supplement

- \* Operate the working light according to actual structure. Working light switch may also locate at the right armrest box.

# About the use of each device

## The adjustment of seat

### Warning

- \* When put down the seat forward, make sure shut off the engine and put the operating handle lock rod first. If not, the drive handle may be moved when put down the seat.
- \* Verify the seat is fixed firmly after adjustment.

The seat can be adjust teroposteriorly.

1. Pull the adjustment handle to right and the seat can be adjusted front and back. Please adjust the seat to suitable position and verify the seat has been fixed firmly .
2. When pull down the seat forwardly , put the operating handle lock rod to "Lock" and shut off the engine . Pull the lock rod forward, and the seat is uplifted.

### Supplement

- \* Please fix firmly the seat lock rod after it restores the normal position.

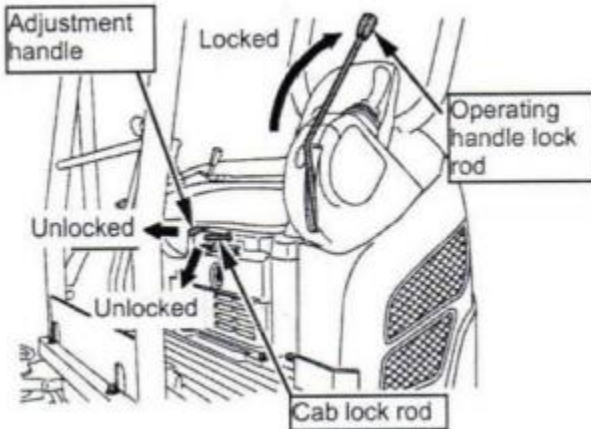

## Open and close of back bonnet

### Attention

Watch your hand when closing the back bonnet **and make sure firmly locked.**

1. Insert the start key and turn right. Back bonnet is unlocked when the start key is vertical. Pull down the button and open the back bonnet transversely

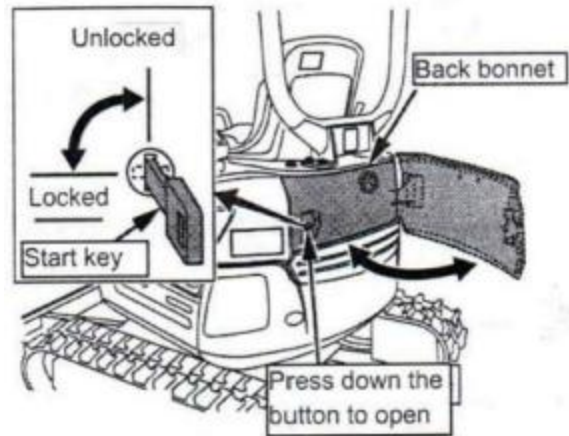

2. Fasten back bonnet with lock rod.

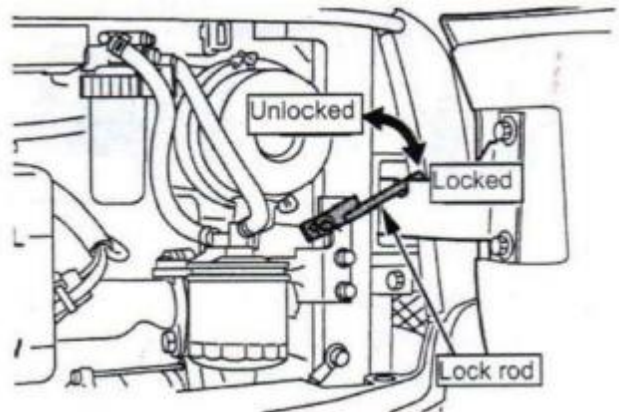

3. Make sure the left bonnet is locked when close the back bonnet, and then push the back bonnet until it sounds "click". Turn left the start key to horizontal to lock the back bonnet.

## About the use of each device

### **Important**

- \* Do not drive with the back bonnet open. If not, the back bonnet would be damaged.

Open and close of left bonnet

1. Disassemble the rubber pad around the switch of the left bonnet. Open the foot pedal.

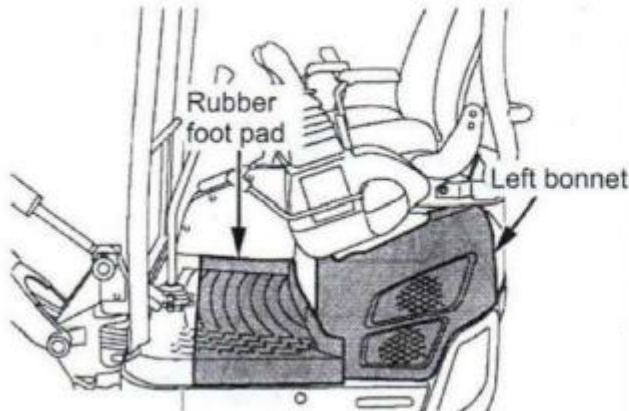

2. When open the left bonnet, open the back bonnet first, and then unscrew the left butterfly nut to unlock the left bonnet.

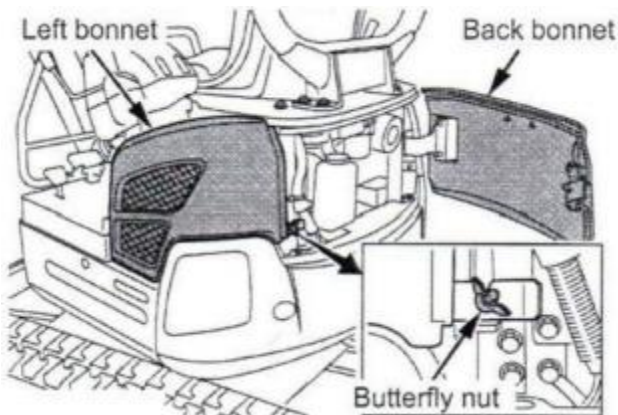

3. When close the left bonnet, close the left bonnet first, and then put the metal lock part to the specified location and screw down the butterfly nut.
4. Put the rubber pad to the original place.

Fuel container cover

1. Insert the start key and turn left. Left bonnet is unlocked when the start key is horizontal.
2. Make sure close fuel container cover. Turn right the start key, and it is locked when the key is vertical.

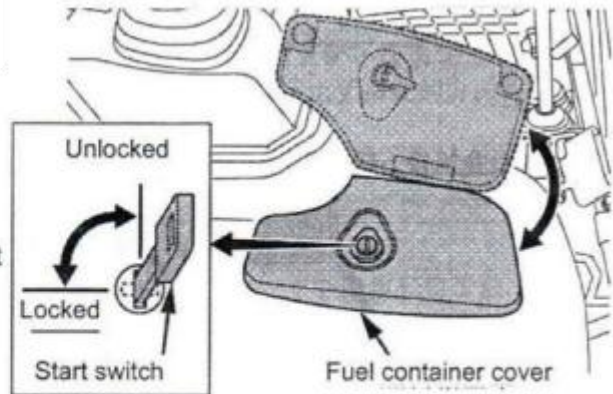

Instructions depositary

Instructions depositary locates in the front of the seat. Please put back the instructions after read it.

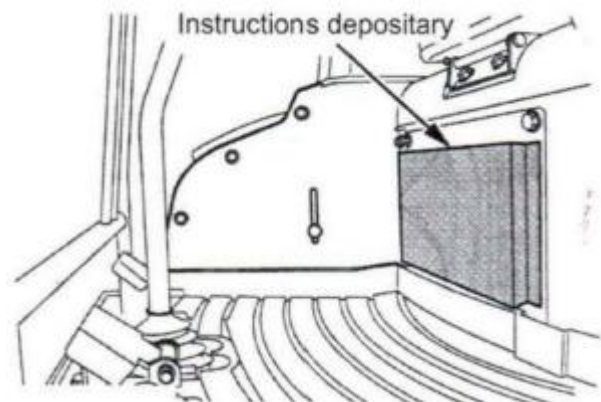

Fire extinguisher depositary

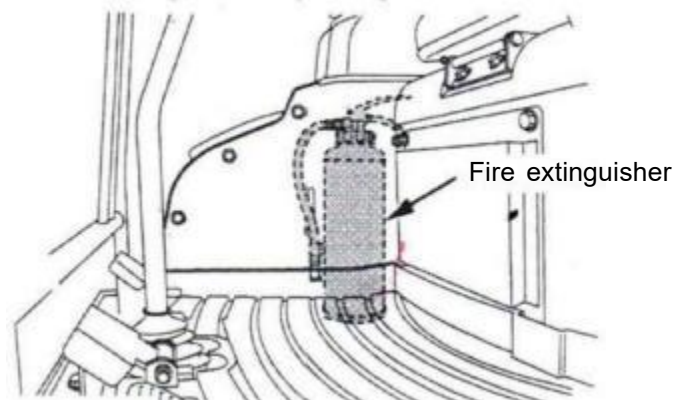

# About the use of each device

## The use of operating handle

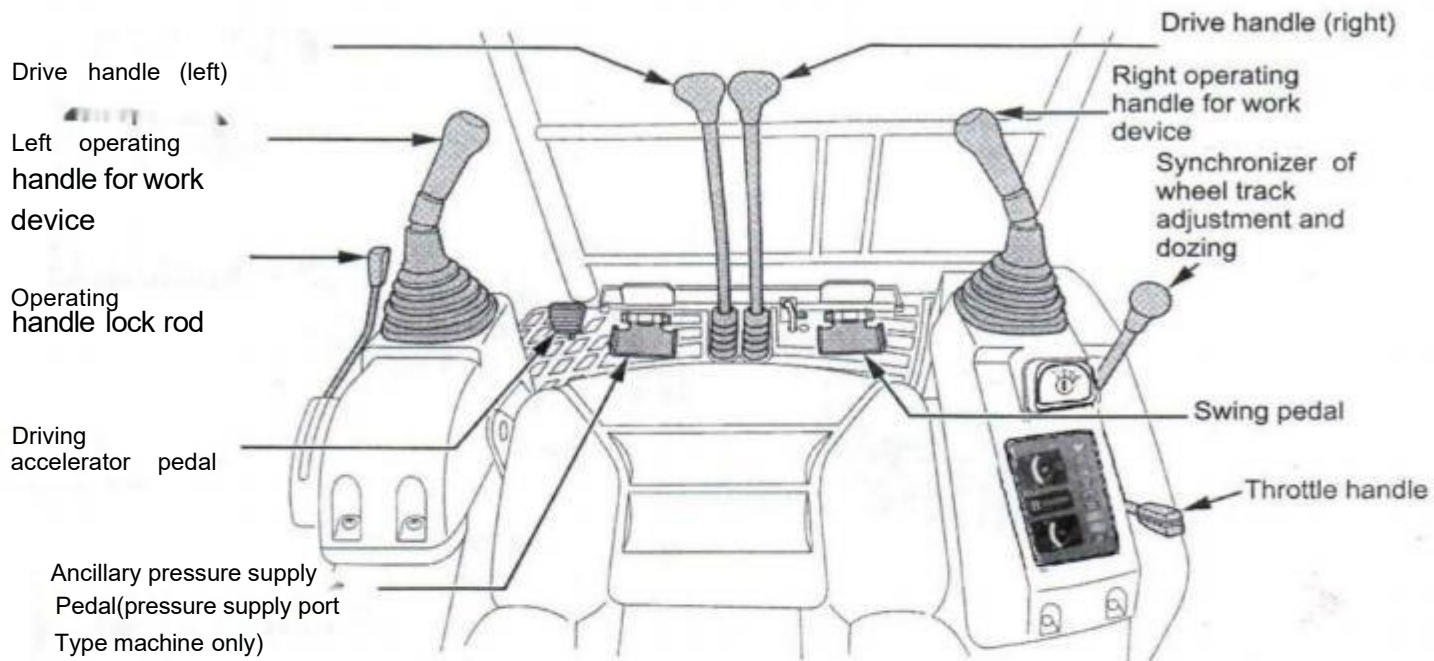

Switcher of wheel track adjustment and dozing

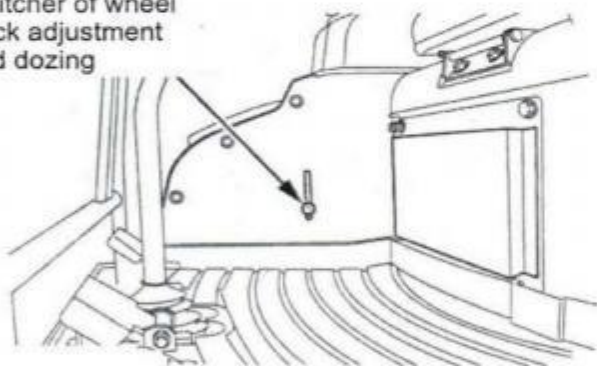

# About the use of each device

## Throttle handle

Sit on the seat

1. The engine revolving speed increases when the throttle handle is pulled to high speed side.
2. When you close the engine, push the throttle handle to low speed side and turn the start key at "Off".

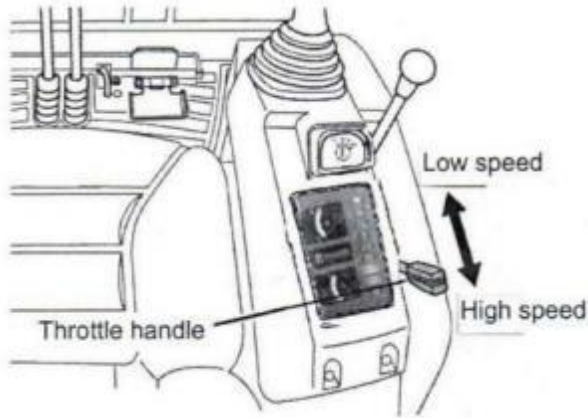

## Drive handle(left/right)



### Warning

- \* Please verify the the dozer blade and front idler are on your front side. If not, the machine may go the opposite direction when operate the handle. Misoperation is dangerous and may cause injury.

Sit on the seat. When the the dozer blade and front idler are on your front side , pushing ahead the drive handle the machine go forward , otherwise, pulling back the driving handle the machine go backward.

## Drive handle(left)

## Drive handle (right)

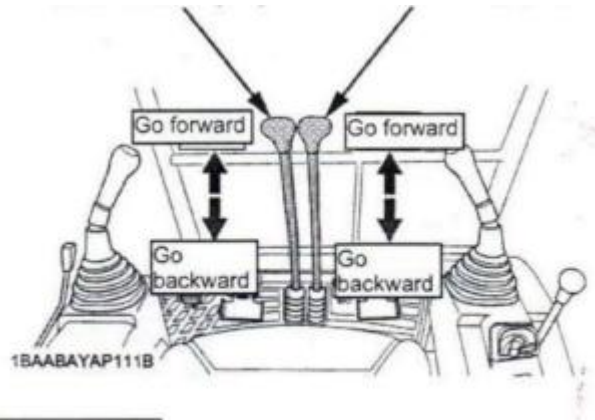

### Supplement

- \* The driving operation can not be achieved if the operating handle lock rod at "Locked". Please put the operating handle lock rod to "Unlocked" when driving.

## About the use of each device

### Working device handle(left/right)

Used to operate the boom, arm, bucket and rotation. The locations and operations of the handle are showed below.

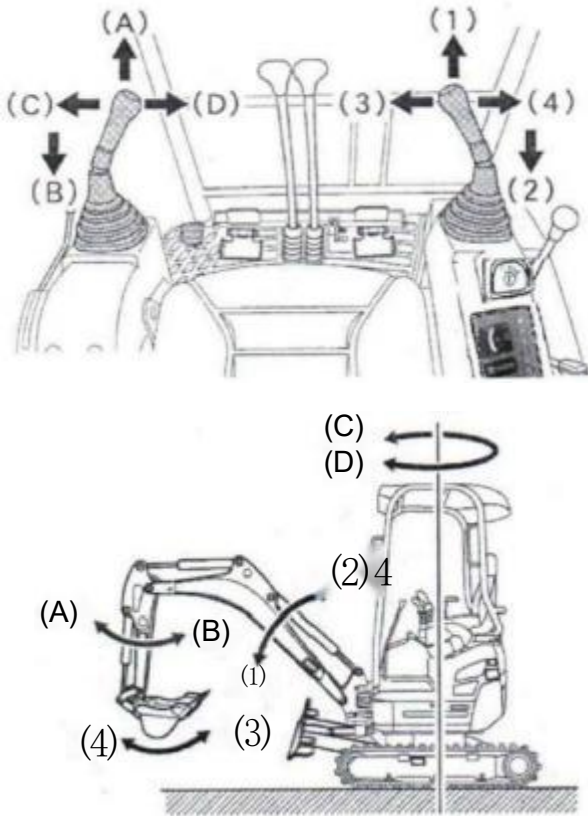

Direction	Working device handle(left)
A	Arm puts out
B	Arm draws back
C	Rotate to left
D	Rotate to right

Direction	Working device handle(right)
1	Boom falls
2	Boom uplifts
3	Bucket draws back
4	Bucket dumps

## Warning

- \* Please do not turn on swing or rotate switch on the slope in case of turnover. Please levelling the ground before work if your have to work on slope.

### Supplement

- \* The working device only can be operated when the engine is starting. Put the bucket down to the ground after the engine is adjust to low-speed running state. When get on or off the cab, please pull up operating handle lock rod to "Locked" position.
- \* Warm up the engine if the hydraulic oil is too cold. The response of the working device would be slowly in low temperature.
- \* The operation of the handle may feel heavy when the hydraulic oil is cold, which do not effect the operation.
- \* When disassemble the hydraulic device and ensure safety please follow the steps below strictly:
  - (1) Slow down the engine speed, and put the bucket down to the ground .
  - (2) Shut off the engine , move the operation handle om nibe aring ly .
  - (3) Wait for more than 10 min to reduce the residual stress of hydraulic circuit.
- \* **Boom operation**  
Buffer structure is used at the end of boom uplift to reduce soil dropping out. When the hydraulic oil is cold(the engine just starts), the buffer time may be a little longer (It is not abnormal).
- \* When the boom falls down, be cautious to avoid bucket teeth catch the dozer blade.

### Important

- \* If the arm towards right down, the arm may pause in puling up process.(It is not abnormal).
- \* The life of the machine would be shortened by fast revolving and fast reversing. Make sure not carry out these operations.

## About the use of each device

### ■ Swing pedal

#### Warning

\* Push the swing pedal forward and lock it when you have no need for swing. Swing may cause injury by misoperation and carelessness.

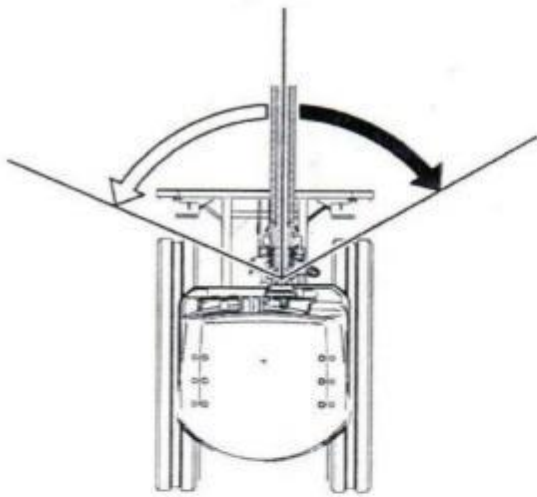
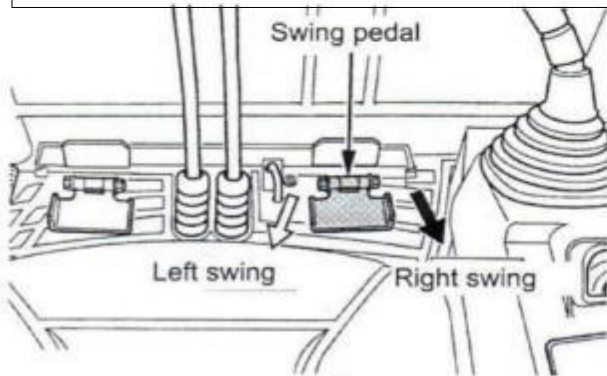

### supplement

\* Push the swing pedal forward when you have no need for swing.

### ■ Wheel track adjustment or dozing

Used as a switch between wheel track adjustment and dozing.

wheel track adjustment ..... Pull up the handle  
dozing ..... Put down the handle

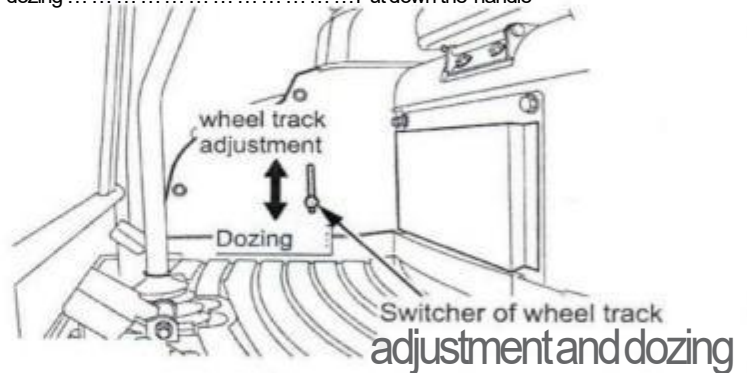

### ■ Wheel track adjustment and dozing

#### ◆ dozing

#### Attention

\* Please put the switcher handle to place when choose operation between wheel track adjustment and dozing. Injury may be caused by unexpected misoperation.

I. Sit on the seat, and put the handle to "Dozing" position.

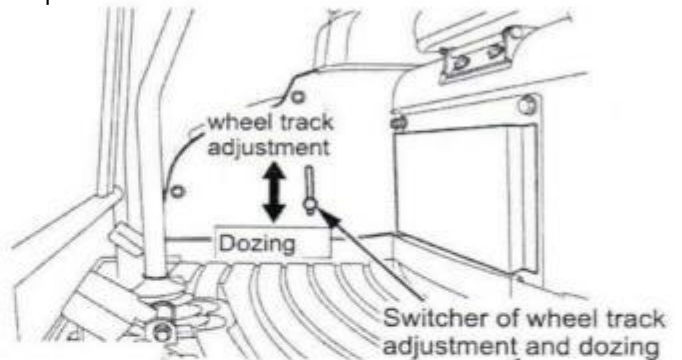

# About the use of each device

2. Please use the synchronizer of wheel track adjustment and dozing to operate the dozer blade.

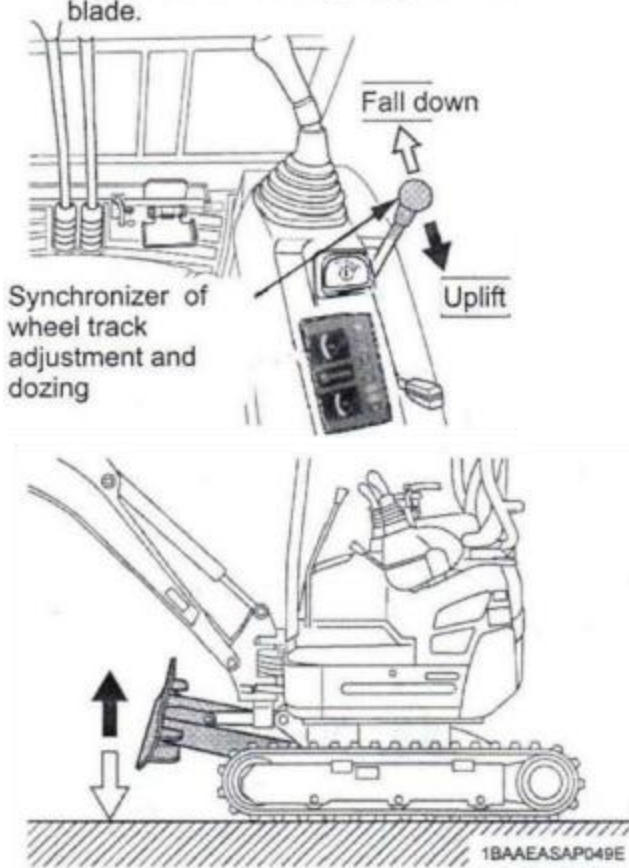

Please operate 2 driving handle using the left hand and operate dozer blade up and down using the right hand.

## Wheel track adjustment



### Attention

\*Please put the switcher of wheel track adjustment; and dozing to place when choose operation between wheel track adjustment and dozing.  
\*Injury may be caused by unexpected misoperation.  
\*Please adjust the wheel track to the minimum 990 mm or the maximum 1240mm. If the wheel track is adjusted to other value, the rotating frame may shakes due to unfixed of the collapsible component.  
\* Shrink wheel track only when passing through flat and narrow place.  
\*Enlarge wheel track to maximum in all other cases. If not, machine turnover may be caused by a narrow wheel track.  
To ensure safety, any people should keep off from the dozer blade when during wheel track adjustment.

Enlarge wheel track to maximum in other conditions in case of turnover.

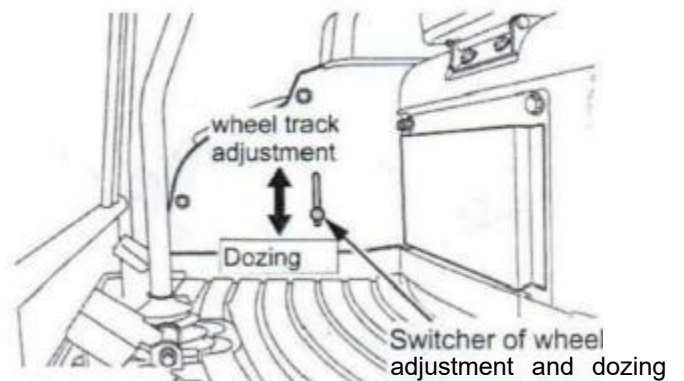

## About the use of each device

2. Please use the synchronizer of wheel track adjustment and dozing to adjust wheel track.

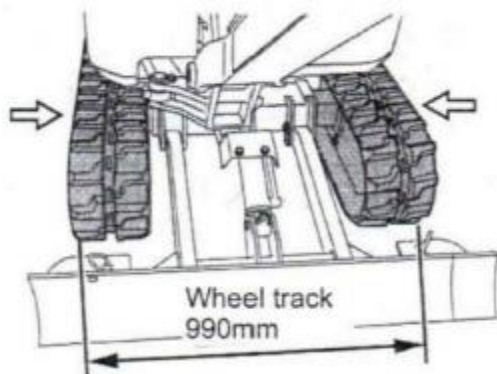
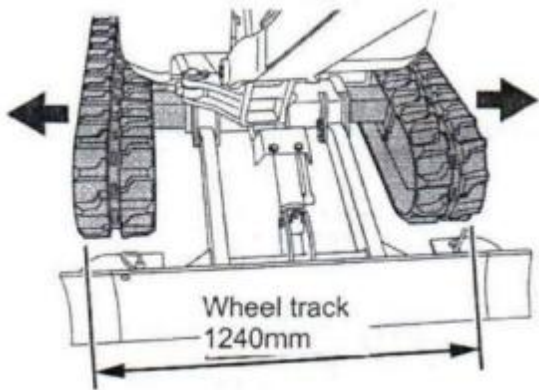
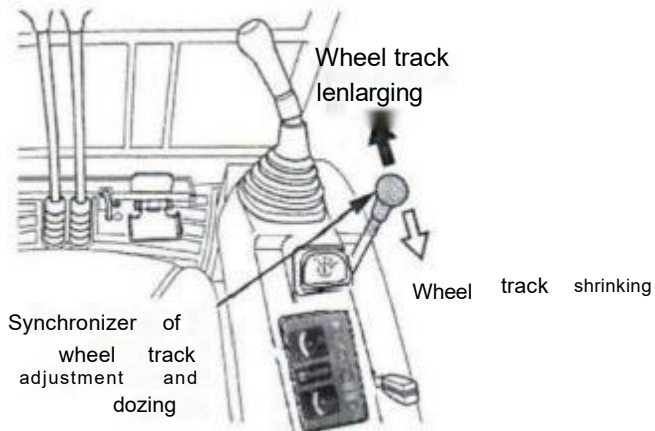

The extended board is used to enlarge the dozer

blade.

When reduce the width of the dozer blade:

1. Pull out the dozer blade pin.
2. Reverse the extended board, and insert

the dozer blade pin when the pin hole align with the minimum width hole.

The method of enlarging the dozer blade is

the same as the above.

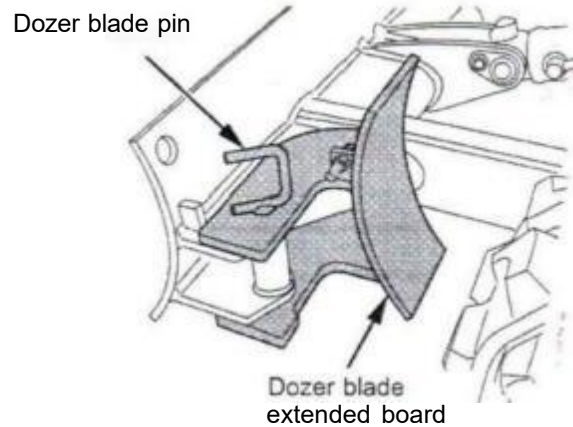
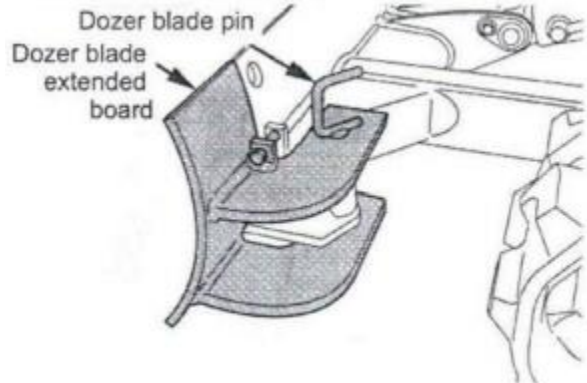

## Important

\* If obstacles exist around to obstruct adjusting the wheel track, please remove the obstacles or drive the machine to a flat place first.

In addition, if adjustment parts are stucked by soil, remove the soil first.

# About the use of each device

## Accelerator pedal

The machine runs faster when the driving accelerator pedal is trampled down and the indicator light turns on at this time .

Loosen the accelerator pedal and it returns to normal driving speed , and the indicator light turns off at this time .

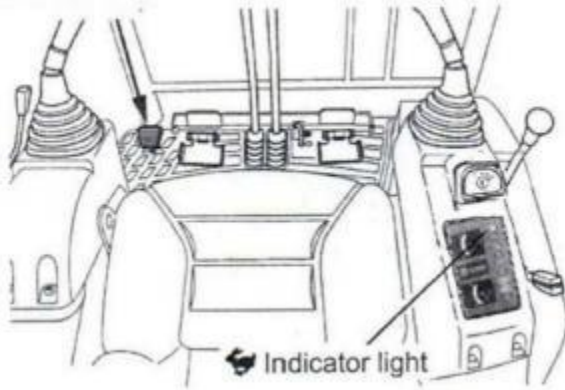

## Supplement

\* If resistance is too large, speeding up may not achieve even though the pedal is depressed.

## Ancillary pressure supply pedal (selective purchasing part)

It is used to operate the breaking hammer .

The type of machine equipped with ancillary pressure supply orifice , when the pedal is trampled down towards the left ,

hydraulic oil flows to the right .(2)

(from the view of the driver)

and when the pedal is trampled down towards the right ,

hydraulic oil flows to the left .(1)

(from the view of the driver)

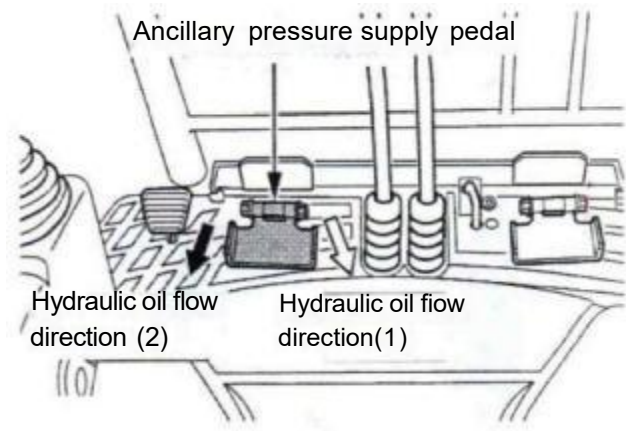
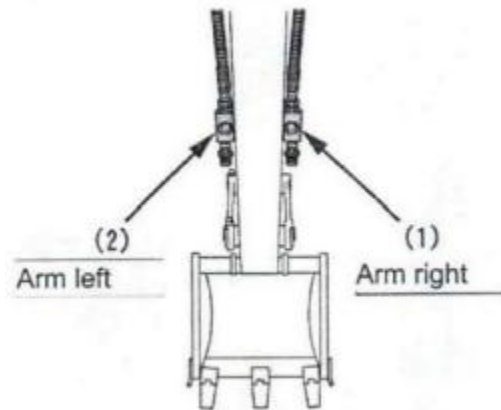

# Check before operation

## Routine check

### Routine check list

Items		NO.	Parts required to add or replace	Reference pag
Parts existed problems last time.				
Check and add coolant		1		18
Oil remainder	(1)Check and add fuel	1	Select diesel oil according to local temperature	19
	(2) Check and engine oil	1	Engine oil (Level CF)	20
	(3)Check and add hydraulic oil	1	Hydraulic oil	20
Grease required to inject	(1)Bucket pin	4	Ultimate pressure required Level EP2 grease	42
	(2)Swing fulcrum pin	2		42
	(3) The root of the boom	1		42
	(4) Boom oil cylinder boss	2		42
	(5)The root of the arm	1		42
	(6)Arm oil cylinder boss	2		
	(7)Dozer blade oil cylinder boss	1		
	(8)Swing cylinder boss	2		
	(9)Dozer blade oil cylinder boss	2		
	(10)Dozer blade root pin	2		
Check and clean water separator				21
Check and sweep radiator and oil cooler				21
Check and sweep battery, wires and engine around				22
Check installation site of the roof				22
Cautions in excavator washing				22

Routine  
Check  
Item

# Check before operation

Grease injection in crawler frame collapsible part  
 Push forward the synchronizer of wheel track adjustment and dozing and adjust the wheel track to maximum.

2. Move the soil around the adjustment parts, and daub grease around the square tube homogeneously (front,
3. back, left and right 4 places)

Adjust the wheel track from the maximum and minimum several times to distribute the grease homogeneously.

	Maximum	Minimum
W-18-3	1240mm	990mm

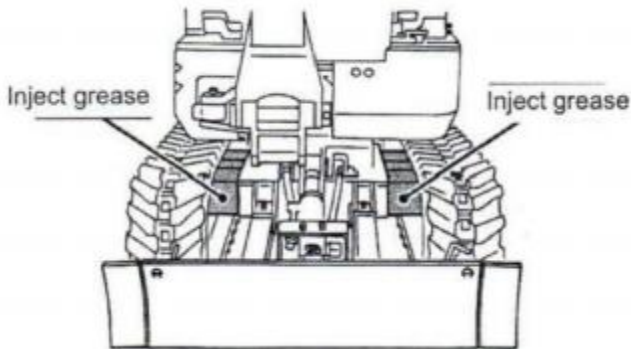

## Supplement

\*Make use of the working device and dozer blade to carry out operations from 1 to 3 above after the crawler is hanged in air.

Check and add coolant



### Attention

\* Make sure open the radiator cover after the radiator cools completely in case of burn by steam or hot water.

Check the coolant in auxiliary water tank is enough or not. The water level should be from "FULL" to "LOW". Add coolant when the coolant is insufficient.

Coolant \_\_\_\_\_ about 2.7L (0.6 L in auxiliary water tank)

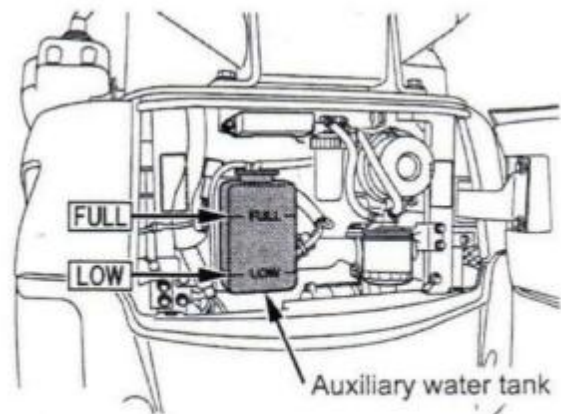
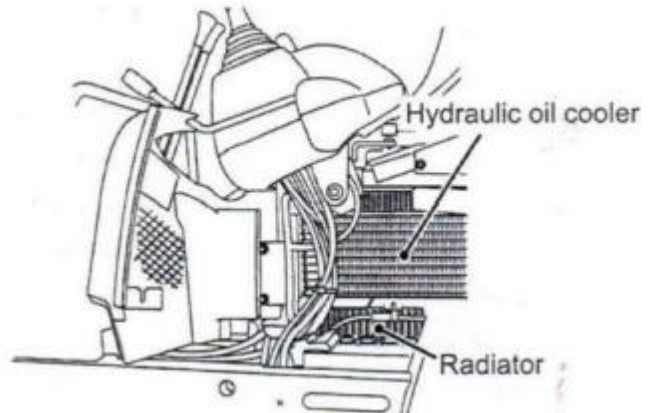

### Important

- \* Do not add the coolant exceeding the maximal level "FULL"
- \* Make sure no't add muddy water or sea water. Do not open the radiator cover in general
- \* condition.

## Check before operation

### Supplement

- \* Check the coolant of auxiliary water tank after the engine cools down.
- \* Long-acting coolant had been add when the machine leaved factory.(mixing ratio: antifreeze fluid 50% ,water 50%)

Check and add fuel



### Attention

- \*Make sure shut off the engine when add fuel.
- \*Make sure not close to fire in case of fire disaster.

1. Check the oil make use of the fuel gauge.  
Fuel gauge works when the start key at "ON".

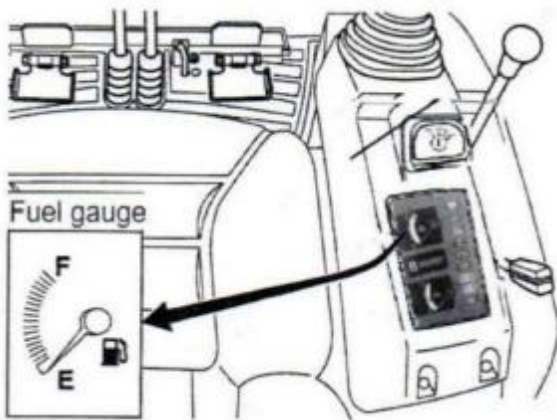

2. Open the fuel container coverplate to add fuel when the fuel is insufficient.

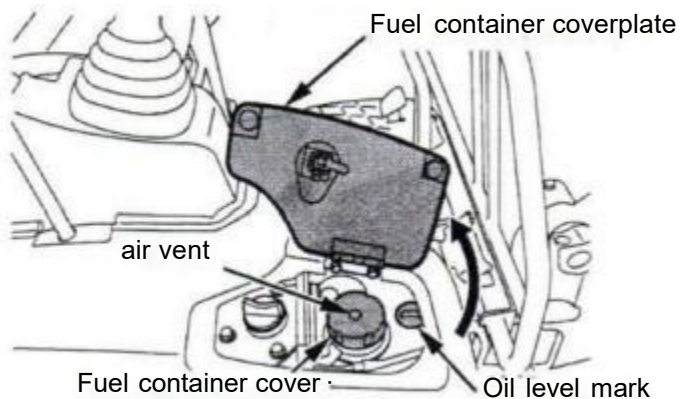

### Supplement

- \* Fill the fuel container after work and tighten the cover.
- \* Oil level mark nearby would wobble when the fuel container is filling.
- \* Make sure add the fuel with the strainer.
- \* Keep off the impurities and water when add the fuel.
- \* Generally, there is no air in the fuel system as long as oil exists in fuel container. If air inflows into the fuel system, please exhaust it first.(Details refer to Chapter "Exhausting of fuel system"of "Maintenance")
- \* Air vent exists in fuel container cover. Negative pressure forms in fuel container if the air vent is clogged by soil. Sweep it when add fuel.
- \* After fill the fuel container, please close the coverplate and lock it with the key.

Fuel container volume	17L
-----------------------	-----

## Check before operation

### Check and add engine oil

1. Check specified volume engine oil has been added.
2. It is normal when oil level mark locates at the range as shown in the following figure.
3. If engine oil is insufficient, open the coverplate (on the left lower of the cab) and add engine oil from the oil tank port. (Refer to Chapter "Recommended grease")

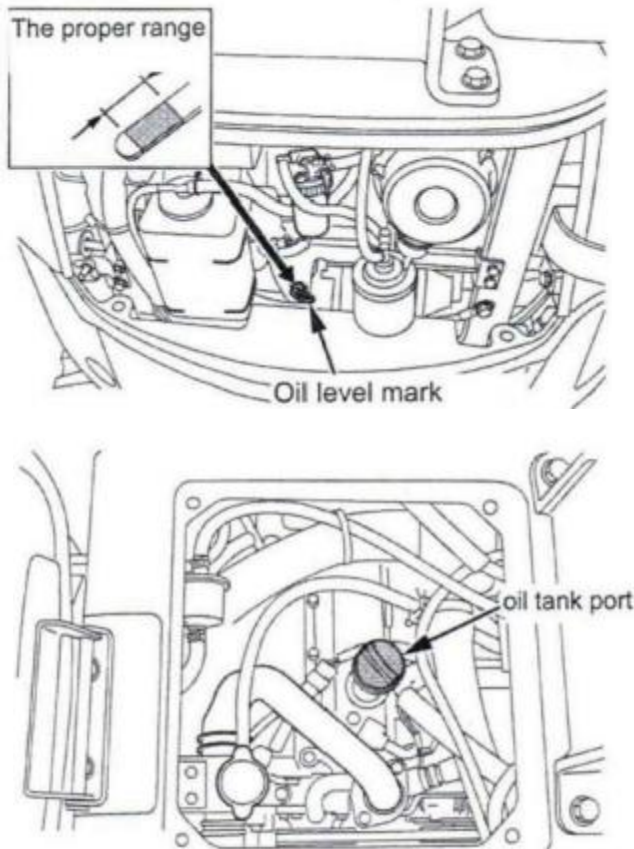

### **Important**

- \* Use the engine oil of proper viscosity according to local air temperature. (Refer to Chapter "Recommended grease")
- \* Check the oil volume after the engine is shut off and the machine locates horizontal for at least 5 min.
- \* Make sure insert the oil level mark after check.

### Check and add hydraulic oil



### **Attention**

- \* Disassemble the hydraulic oil tank port after the oil is completely cold in case of scald.

1. Enlarging the wheel track to the maximal (1240mm).
2. Park the machine on horizontal place and put the arm and bucket to the limited state, and put the bucket down to the ground.

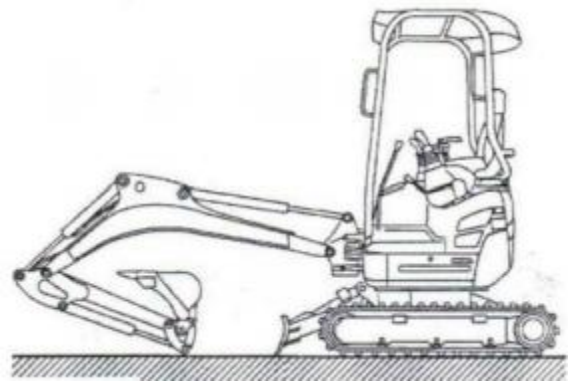

3. Check the hydraulic oil volume is in the middle of oil level meter in normal temperature (10~30°C)
4. It is normal when oil volume is in the middle.
5. Add oil when the oil is insufficient.
6. Replace the hydraulic oil completely if water or impurities are mixed in the oil. Please refer to the Chapter "Maintenance after working per 1000h" and "Change hydraulic oil" of "Maintenance"

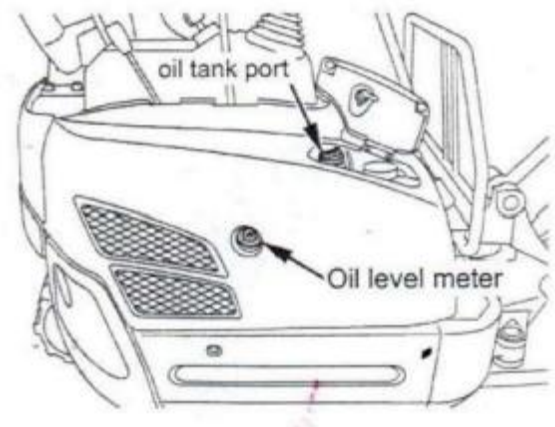

## Check before operation

### Important

- \* When add the hydraulic oil, sweep the sand and ordure around. Make sure add the hydraulic oil of same brand. The hydraulic oil brand refer Chapter" Recommended grease". (Do not mix hydraulic oil of different brands)

Check and clean water separator

Water and sediment in fuel would precipitate into the water separator. When water and sediment are overmuch, put the water separator handle to "CLOSE", and loosen the fixed ring, and disassemble the oil cup, then remove water and sediment and wash the interior of the oil cup. Exhaust air from the fuel system at this time.

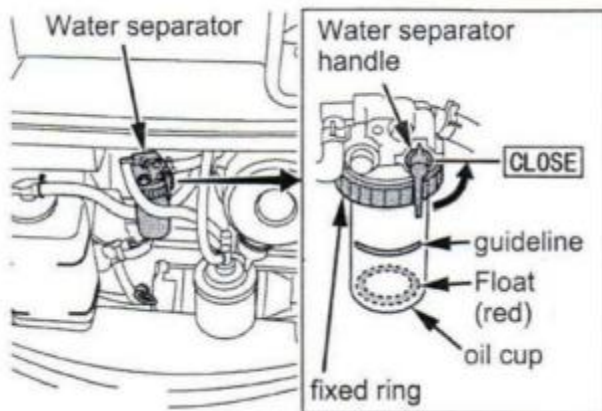

### Important

- \* The red float floats up when water exists in the oil cup.
- \*Exhaust water immediately when the float rise to the guideline.
- \*Keep off chippings and dust when assemble the water separator.
- \*Make sure operate the machine after air is exhausted from fuel system.(Refer to Chapter "Exhausting of fuel system"of "Maintenance")
- \* If the water separator is Fleetguard brand from Shanghai, please check and wash the separator according the directions

Check and sweep radiator and oil cooler

- 1.The radiator and hydraulic oil cooler can be seen when left bonnet is opened.
2. If the cooling fin is clogged, please wear safety goggles to sweep the cooling fin with compressed air.
- 3.Check the radiator hosepipe.  
If the radiator hosepipe exists cracks or is damaged, please replace it.  
In addition, verify the pipe clamp is tightened.

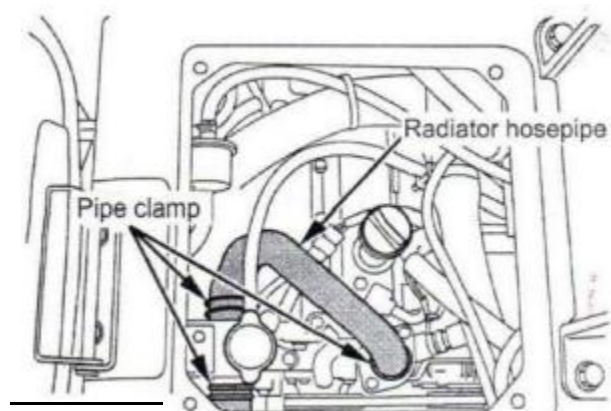
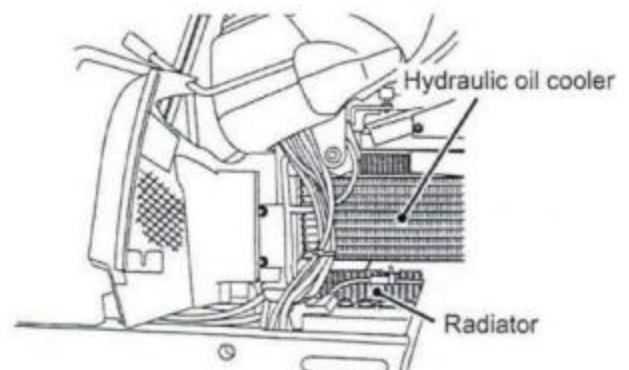

### Important

- \* The fins of radiator and hydraulic oil cooler are liable to deform. Be cautious when sweep them in case of deformation. The deformation may cause overheating of some parts and hydraulic oil, thus resulting in mechanical breakdown.

## Check before operation

---

- Check and sweep storage battery, wires and engine around



### Attention

\* The damaged harness and wire of battery positive pole would cause short-circuit. Make sure check them.  
· Fire may be caused by attached ordure or fuel on battery, wires, muffler and engine. Check them daily before work.

### Cautions in excavator washing

1. The behaviors would get disorders if water inflow into the electrical system. Therefore, do not purling water to sensors, connector and other electronic components

2. Please shut off the engine before excavator washing. Do not purling water to air filter.

The wrapper of harness and wire of battery positive pole would be natural ageing. Please check the items below:

1. No harness is damaged. No clip is loose.
2. The connections of terminals, sockets can not be loose.
3. All the switches works well.

— Check installation site of the roof

### **Important**

\* The roof is used to keep out of rain and block the sunshine. Head protection can not provide by the the roof.

1. Make sure no bolts is loosening or deformation. If abnormity appears, tighten or replace the bolts.
2. Do not disassemble the roof.  
If necessary, assemble with suited bolts (M14 × 1.5 × 35) and tighten them with stated torque according to the following torque.

Tightening torque	124~ 141N·m 12.6~15.0kgf·m
-------------------	-------------------------------

# Engine start and shut down

## Engine start



### Warning

- \* Please be seated in the seat and verify all handles and pedals locate in default positions before start the engine. Otherwise, the machine may move when start the engine due to carelessness. It is dangerous.
- \* Tail gas exhausted from engine is poisonous and people may be poisoned when working indoor. Make sure ventilate sufficiently when work indoor.

Start the engine follows the steps below.

1. Verify all handles and pedals locate in default positions.

Put the operating handle lock rod to "Locked" position.

The engine can not be started when the operating handle lock rod locates in "Unlocked" position.

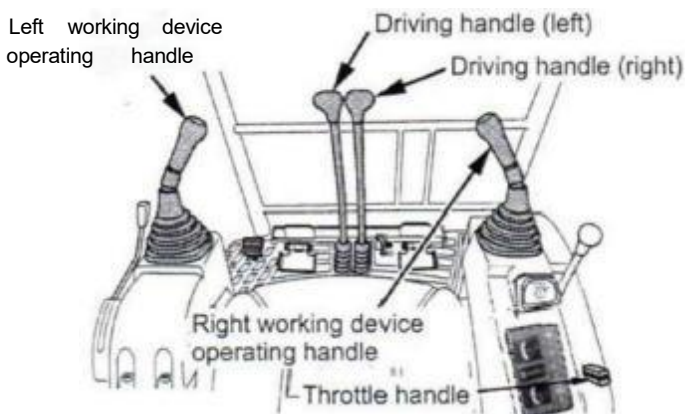

2. Insert the start key in the starting switch.
3. Pull the throttle handle backward to the limit.
4. Turn the start key to "ON" and hold for at least 3 s (preheat time)

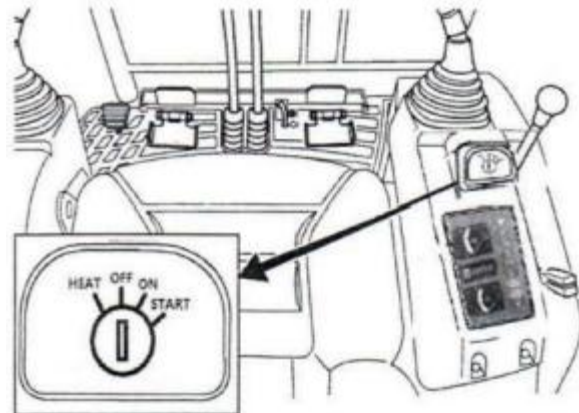

5. Continue turning the key to "START"
6. Release the key after the engine starts and it return to "ON" automatically.

### Important

\*Keep the start key in "START" position during engine working. If not, breakdown may be caused.

\* Do not continuously start the engine for more than 10 s, because starting motor takes lots of energy.

\* If the engine can not be started in 10 s, please turn the key to "OFF" and wait for at least 20 s, and then reoperate follows step 4, 5, 6 above.

\* If battery energy exhausts, make sure charge the battery with 12V battery. Do not use 24 V battery to charge.

### Important

\* If the the key put in metal key chain, which obstruct signal transmission between the key and the switch, causing the engine unable to start normally.

#### Start in cold season

1. Pull the throttle handle backward to the limit.
2. Turn the start key to "HEAT" and hold for at least 5 s.)
3. Turn the start key to "START" position.
4. Release the key after the engine starts and the key return to "ON" automatically.
5. If the engine is not started, please turn the key to "OFF", and then reoperate step 2,3,4 above.

# Engine start and shut down

---

## Check after engine start

---

### Warm running

After starts, the engine needs warm running to steady idling state.(It takes about 5 min)

### Supplement

- \* Warm up the engine if the hydraulic oil is too cold. The response of the working device would be slowly in low temperature.
- \* The operation of the handle may feel heavy when the hydraulic oil is cold, which do not effect the operation.

### Check each part

After the engine warms up, please verify the items below.

- The engine light turns off ?
- Battery light turns off ?
- The tail gas color is normal?
- Abnormal sound or vibration appear?
- The oil, fuel, or water leak ?

**Shut off the engine immediately in the following conditions.**

1. The engine rotating speed decreases or increases dramatically.
2. Abnormal noise appears suddenly .
3. The tail gas color goes worse .
4. Engine oil light turns on during working.

### Important

- \* Please refer to "Questions and solutions of backhoe excavator" after the engine is shut off. Other questions please refer to the dealer or manufacturer.

## Cautions in overheating



### Attention

\*Make sure open the radiator cover after the radiator cools completely in case of burn by steam or hot water.

The alarm blows when the temperature of the coolant approaches or exceeds the boiling point (overheat). Please take the following steps at this time.

1. Stop work at a safe place.  
(Take off the engine load)
2. Do not shut off the engine suddenly. Shut off the engine after idling runs for about 5 min.
3. Please wait for 10 min, or keep off the machine when the steam runs out from the machine .
4. Verify there is no dangerous of burning, and refer to "Questions and solutions of backhoe excavator " to find out the overheat reason. Then restart the engine .

## Engine start and shut off

### Engine shut down



#### Warning

- \* Do not hang the working device and dozer blade in air when the engine stop runs. If not, the devices would fall down by gravity and cause accidents.

Push the throttle handle to the limit of low speed and keep the engine idling runs for about 5 min to cold the engine slowly.

1. Put the working device down to the ground slowly.
2. Turn the start key to "Off" to shut off the engine, and pull out the key.
3. Pull up the operating handle lock rod to "Locked" position.

#### Important

- \* Put the bucket down to the ground before shut off the engine. Do not make it touch the ground depending on gravity.
- \* The engine may not be shut off when the throttle handle is at high speed state. Please put the throttle handle to low speed state and turn the key to "Off".

### Fuse for emergency shut off



#### Attention

Do not open the bonnet before then engine stops. Open the bonnet only when the engine can not be shut off by the key. Pull out the fuse to shut off the engine at this time.

Disassemble the fuse box and pull out the fuse, and the engine stops. The engine restart after the fuse is installed.

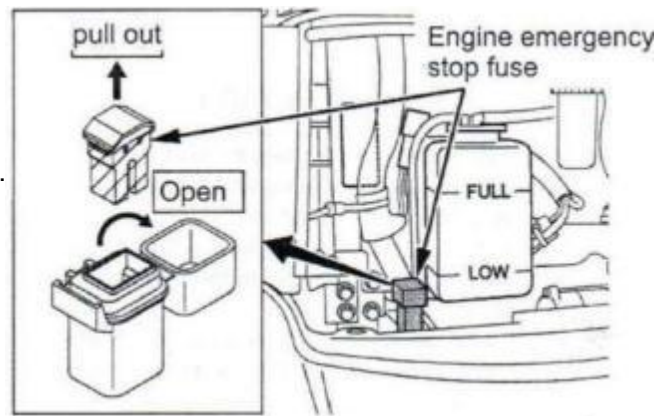

#### Supplement

- \* If the engine can not be shut off by the key, please contact the dealer.

# Backhoe excavator operation

## Running-in

### **Important**

\* The service condition of the first 100 hours determines the service life of the machine. Please work with the machine cautiously. Do not apply too heavy load especially for the new machine.

Keep the imposed load under 50% in the first 50 hours. Keep the imposed load under 70% in the first 100 hours.

Start, running



### **Warning**

Make sure the safety around before work. Verify the dozer blade and front idler locations before operation to ensure safety.

If the dozer blade and front idler locate behind the cab, the machine runs contrary to the operation direction of the driving handle.

Injury would be caused by operation under situation of the machine behavior is not in accord with the recorded mode.

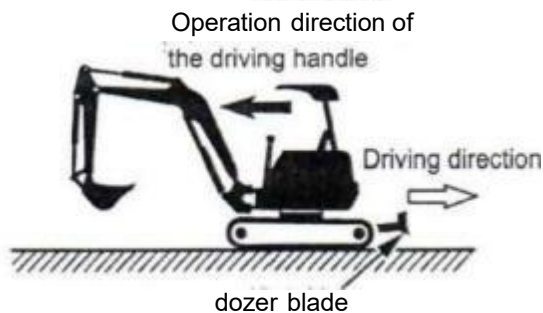
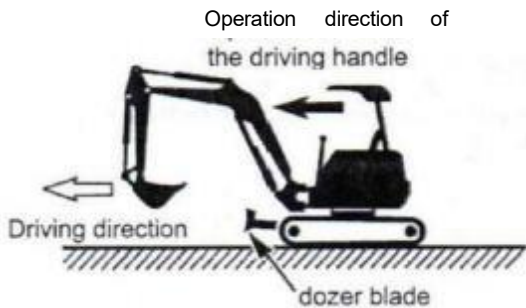

\* Do not run on slope more than 15° in case of turnover and injury.

1. Put the Stop pin in "Locked" position to lock the rotating frame and crawler frame.
2. Press the operating handle lock rod to "Unlocked" to draw back the working device and put the bucket 20 ~ 40 cm above the ground.

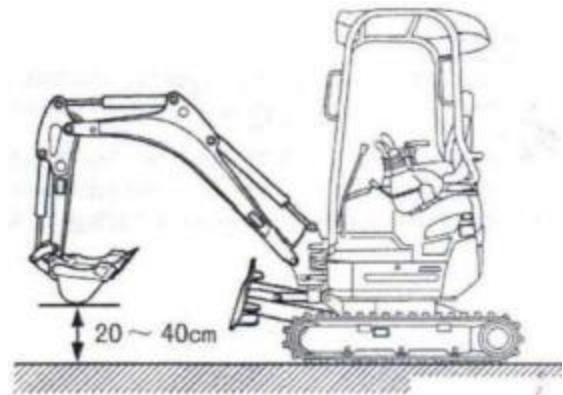
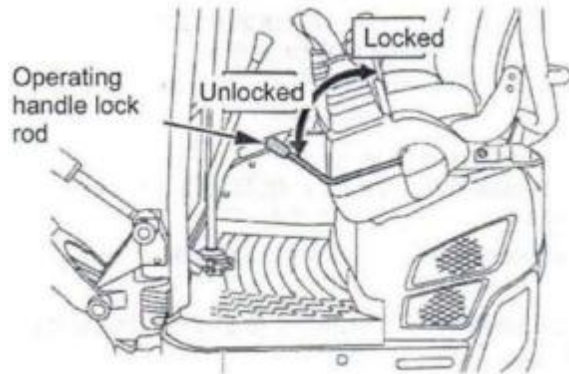

3. Pull backward the synchronizer of wheel track adjustment and dozing to uplift dozer blade.

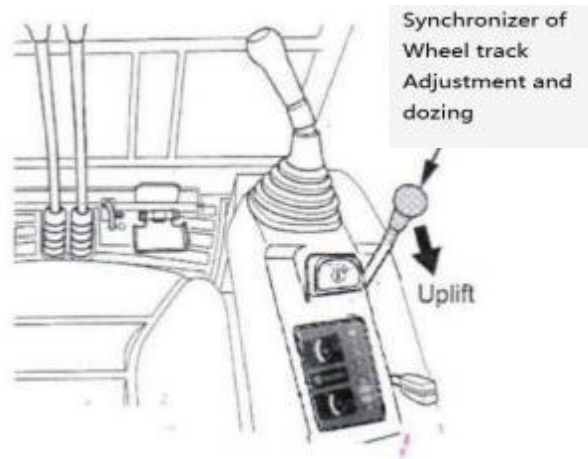

# Backhoe excavator operation

4. When push the driving handle forward or backward slowly, the machine runs.

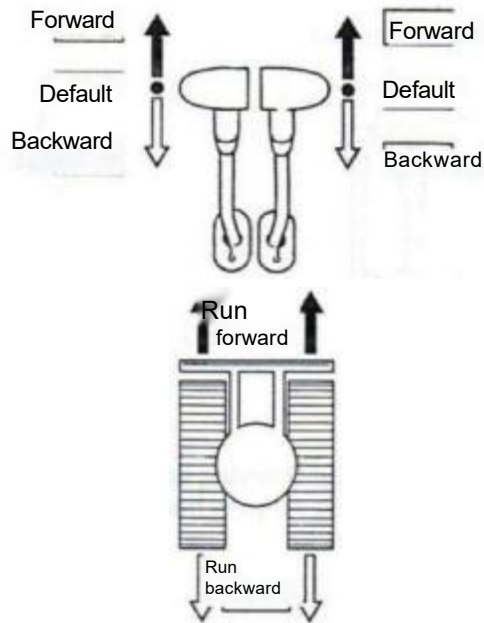

5. High speed driving  
The machine runs faster when the driving accelerator pedal is trampled down and the indicator light turns on at this time.  
Loosen the accelerator pedal and it returns to normal driving speed, and the indicator light turns off at this time.

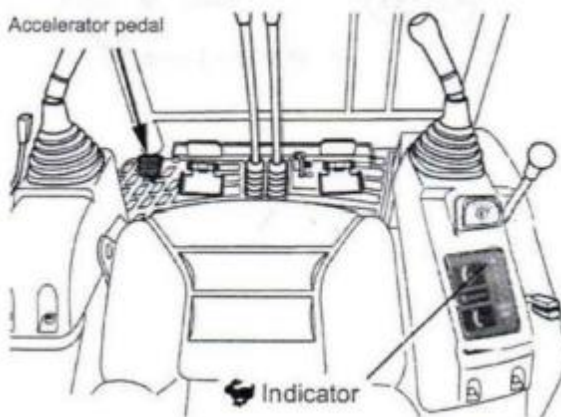

## Attention

When the driving resistance is too large during going up the slope or running on rough ground, do not use the accelerator pedal.

When drive on soft ground, the crawler may be stuck by soil and stone, causing the machine unable to move. In order to remove the soil and stone, please hang the crawler in air and revolve it by operating boom, arm and bucket.

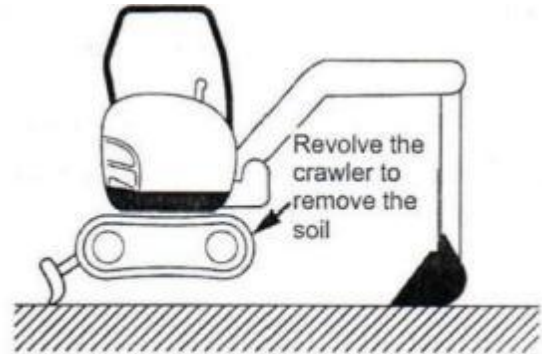

# Backhoe excavator operation

## Swerving



- \* Do not swerve or turn round on the slope in case of turnover. Swerve at flat ground.
  - \* Swerve after verify that no people is around.
  - \* Try to avoid swerving forcibly inplace or circle round. Instead, swerving by running ahead repeatedly.
- Injury may be caused by carelessness.

The operation description when the dozer blade locates forward is shown below.

### Swerve during running

1. Put the left(right) driving handle in default position during running forward, the machine turns to left(right).

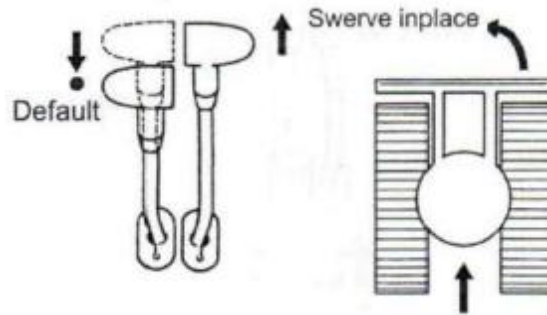

2. Put the left(right) driving handle in default position during running backward, the machine turns to left(right).

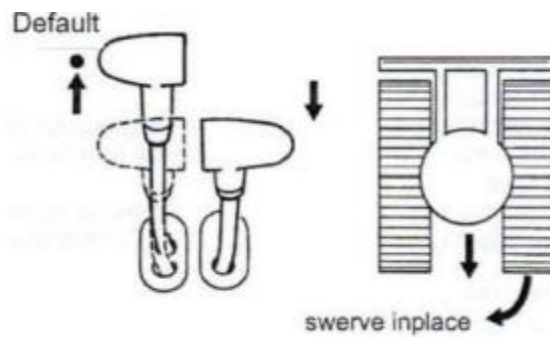

# Backhoe excavator operation

## Swerve during stopping

1. Push the left(right) driving handle forward, the machine turns to right(left).

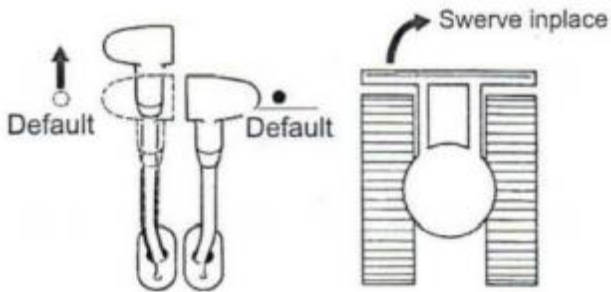

## Swerve circle round

1. Push the left(right) driving handle forward and push the right(left) driving handle backward, the machine turns circle round to right(left).

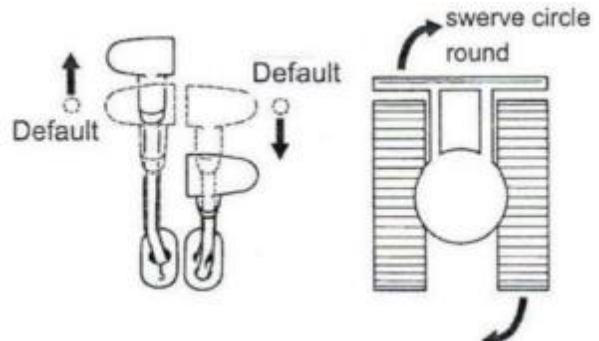

2. Push the left(right) driving handle backward, the machine turns to right(left).

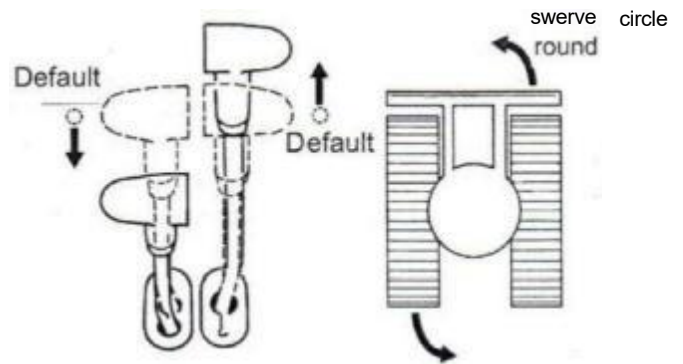
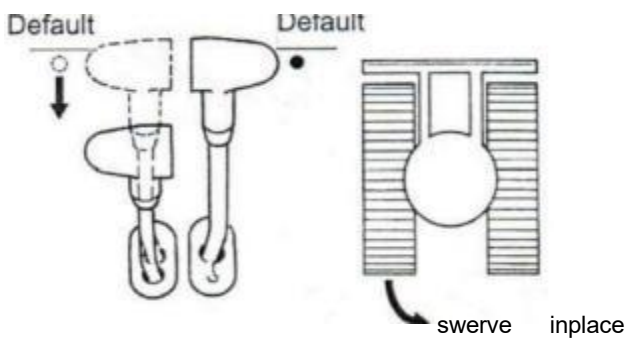

# Backhoe excavator operation

Go up and down the slope



## Warning

\* When drive on slope, make the rotating frame parallel to crawler frame and fix the rotating frame with the Stop pin. Injury may be caused by turnover due to main body moving to the opposite direction.

Enlarge wheel track to Max. When drive on slope. if not, machine turnover may be caused when passing through uneven place.

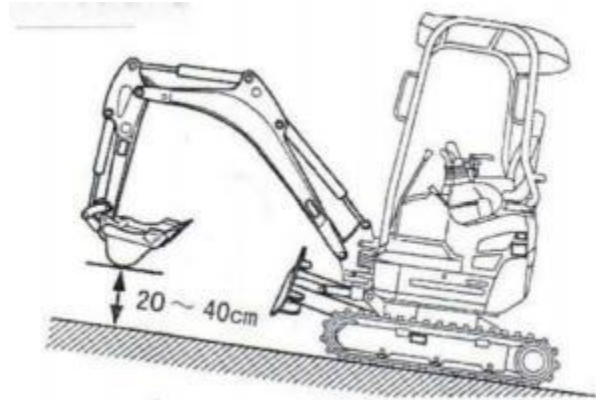

Go down the slope

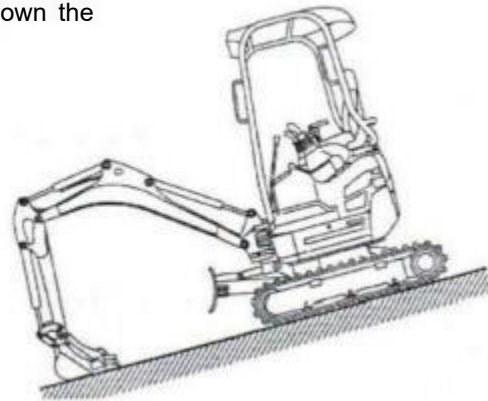

1. Please put the bucket 20~40 cm above the ground when go on the slope.
2. When go down an abrupt slope, put the bucket down to the ground and go down the slope with the pushing of the bucket. When go down a gentle slope, put the bucket down to lower height to the ground.
3. Adjust throttle handle and drive slowly when go up or down slope.

## Supplement

\* Put the operating handle lock rod to "Unlocked" position and pull up the Stop pin when operate the working device.

## Backhoe excavator operation

### Parking at sloping floor



### Warning

\* It is dangerous when park on slope. Do not park on slope.  
If you have to park it on the slope, put bucket teeth into the ground and apply braking measures after all handles put in default position.  
Be cautious of injury caused by sliding down of the machine.

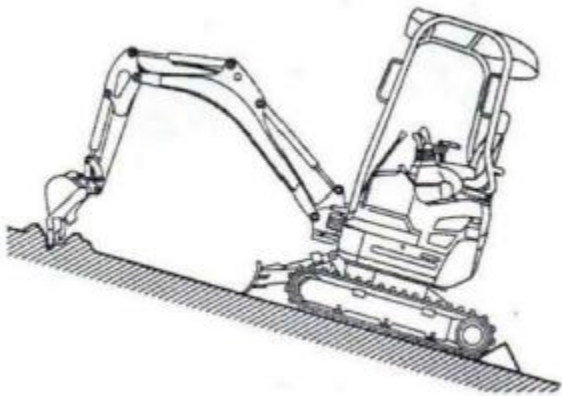

### Parking

1. Park the machine in flat and solid place. Put the arm vertically and put the bucket and dozer blade down to the ground.
2. Push the throttle handle to the limit of low speed and keep the engine idling runs for about 5 min to cold the engine slowly.
3. Turn the start key to "Off" to shut off the engine, and pull out the key.
4. Pull up the operating handle lock rod to "Locked" position.
5. When you leave the cab seat, please close all the covers and close the door.

# Backhoe excavator operation

## Wheel track adjustment



### Attention

- \* Please adjust the wheel track to the minimum 990 mm or the maximum 1240mm. If the wheel track is adjusted to other value, the rotating frame may shakes due to unfixed of the collapsible component .
- \* Shrink wheel track only when passing through flat and narrow place.
- \* Enlarge wheel track to maximum in all other case ,if not ,machine turnover maybe caused by a narrow wheel track

1. Please pull up the switcher of wheel track adjustment and dozing to the limit.
2. Please use the synchronizer of wheel track adjustment and dozing to adjust wheel track.  
Push forward the synchronizer handle.  
... .. enlarging the wheel track (990 mm to 1240 mm)  
Pull backward the synchronizer handle .  
... .. shrinking the wheel track (1240mm to 990mm)

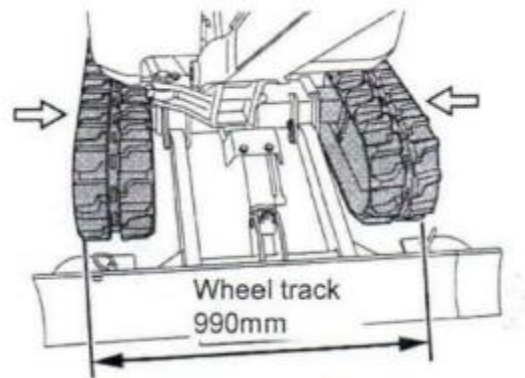
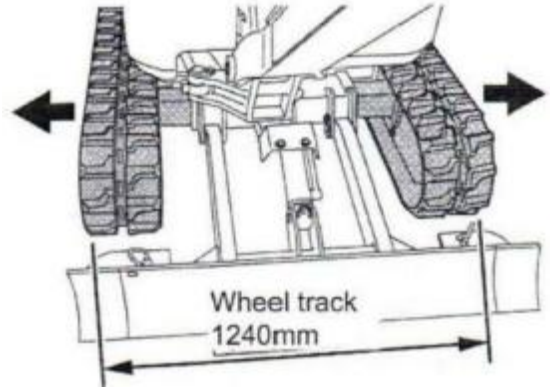
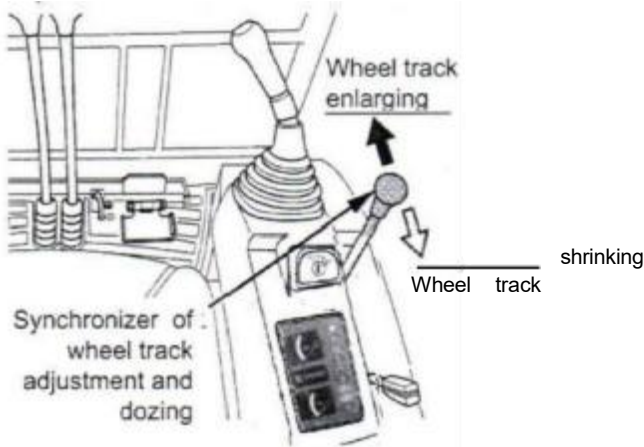

### Important

- \* If obstacles exist around to obstruct adjusting the wheel track , please remove the obstacles or drive the machine to a flat place first. Otherwise , hang the crawler in air using the working device and dozer blade to adjust the wheel track. In addition , if collapsible components are stucked by soil , remove the soil first.

## Backhoe excavator operation

The extended board is used to enlarge the dozer blade.

The maximal width of dozer blade is 1240 mm.

The minimal width of dozer blade is 990mm.

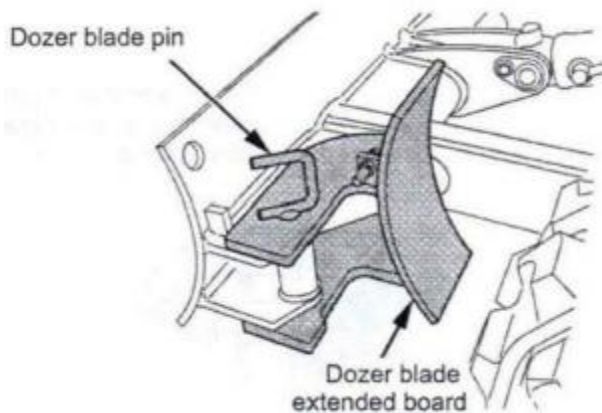
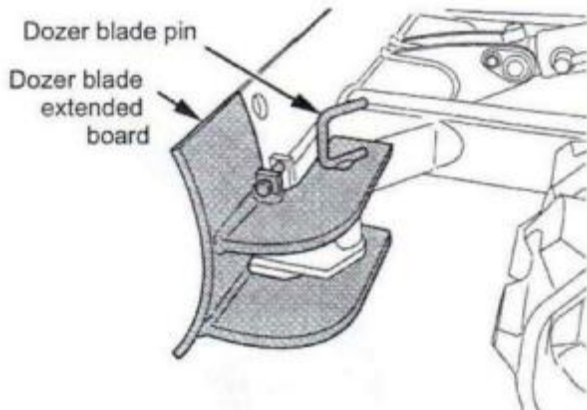

When the width is adjusted from the maximum to the minimum:

3. Pull out the dozer blade pin.
4. Reverse the extended board, and insert the dozer blade pin when the pin hole align with the minimal width hole.  
The method of enlarging the dozer blade is the same as the above.

### Prohibitions

1. Do not work with rotating force. (Do not implement horizontal pushing work with the bucket.)

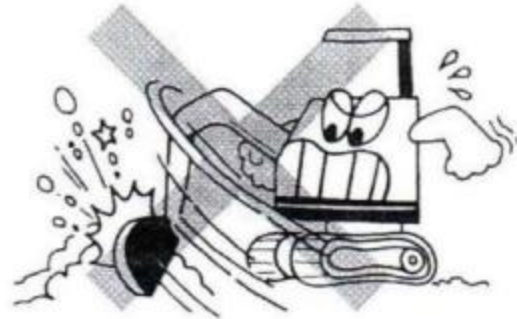

2. Do not work with bucket gravity. (Do not implement palification work with the bucket.)

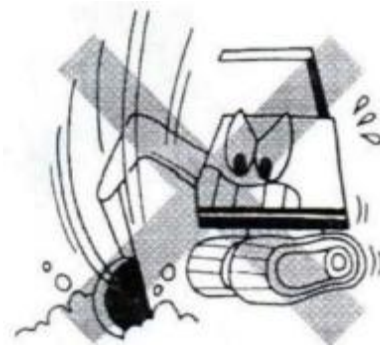

3. Do not work with machine gravity. (Do not implement excavation work with the machine falling force.)

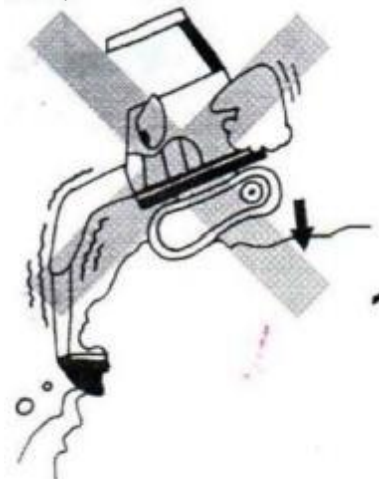

# Backhoe excavator operation

## Cautions during working



1. Be cautious of dozer blade.  
Do not make the boom touch the dozer blade when deep excavates.

4. Do not work with the driving force. (Do not drive with the bucket inserted in earth)



2. Be cautious of the folding of the working device.  
Do not make the boom touch the dozer blade when fold the working device in driving or transporting state.



5. Remove soil with the bucket. (Do not remove soil by knocking with the bucket ends)



3. Be cautious of collisions of the dozer blade.  
Do not make the dozer blade strike the stone in case of premature damages of dozer blade and oil cylinder.



## Backhoe excavator operation

---

4. When dozer blade is used to support the machine, make sure to support the two sides!  
Do not support the machine by one side of the dozer blade.

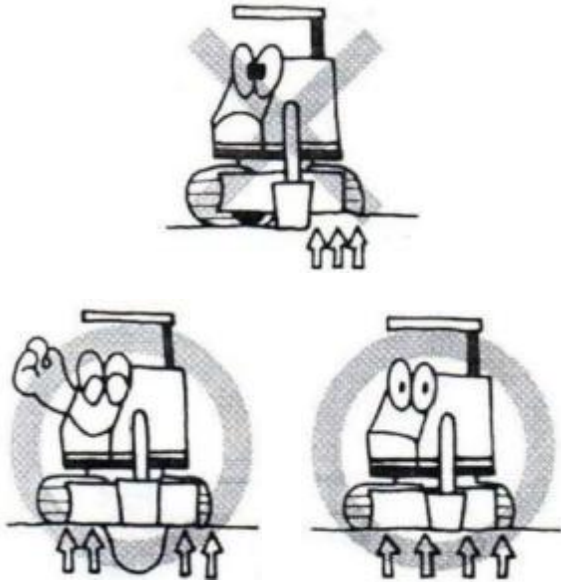

5. Be cautious of the permitted depth of water!  
When work in water, verify that all pins and plugs are fixed firmly and the depth of water should be below the upper surface of the crawler.

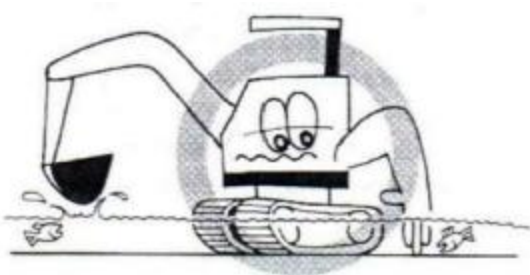

---

### **Important**

- \* Remove all the soil, clean the machine, and inject grease after work.
- \* Wash the machine carefully to remove the salt and maintain the electrical components sufficiently after work on sea shore in case of corrosion.

# Truck transportation



## Warning

- \* Use a truck with appropriate weight and size. Do not overload.  
The truck cab may be uplifted and cause safety hazard as a result of carelessness.
- \* Fix the plate firmly to the truck carriage.  
Keep the plate off of soil and water to avoid slipping, especially for woody plate.  
Falling down or turnover may be caused by carelessness.
- \* Do not lift the excavator by operating the boom and the arm to load or unload when the platform and plate are unavailable. Falling down or turnover may be caused by carelessness.

## Loading and transportation



## Attention

- \* Do not load with arm putting out. If not, the safety of driver and people around would be endangered by orthocenter shift.

1. Brake all truck wheels when load and unload the machine.

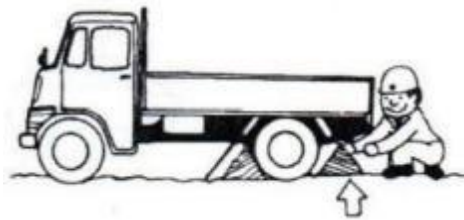

2. The platform should have enough strength and width.
3. Use a plate with enough strength and width to load or unload if necessary. The plate length should be more than 4 times than the height of the truck carriage. Make sure work on a flat and solid ground. Hook the plate on the truck carriage parallelly and align to the crawler. Make sure there are no cracks in the plate. In addition, take a support or block under the plate to avoid excessive bend.
4. Orientate the work device to the driving direction. Make the arm perpendicular to the plate or drawing back slightly. Keep a distance of 20~40cm from the bucket to the plate.

# Truck transportation

## Unloading from the truck

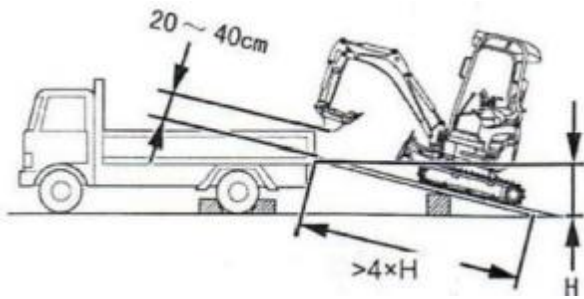

5. Stop moving the machine onto the truck at the state shown in the following figure. Move forward again after put the bucket down to carriage floor. Keep the machine horizontal afterwards.

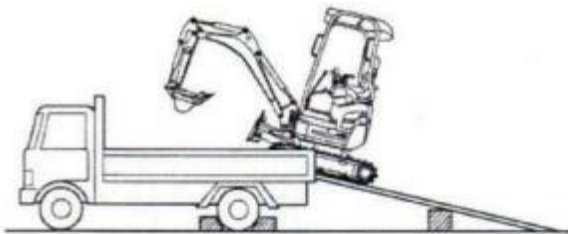

6. It is dangerous to adjust the direction of the machine on the plate.  
If necessary, make sure that move the machine down to the ground first. Then move it onto the plate after direction adjustment.
7. When the machine is moved to the specified location, keep balance and revolve 180° of the upper part slowly with the arm drawing back.
8. Put the bucket down to the carriage floor. Shut off the engine and put the operating handle lock rod to "Lock" position.
9. Fix the machine firmly to the truck carriage with wireropes.

1. Orientate the work device to the driving direction. Make the arm perpendicular to the carriage floor or drawing back slightly. Move the machine to the plate front.

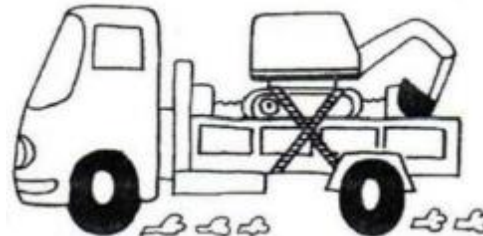

2. Stop driving the machine before it is moved to the plate. Put the bucket down to the ground or the plate and move the machine slowly.
3. Stop driving the machine when half length of the crawler is moved out the carriage. Uplift the boom slowly and drive the machine to the plate.
4. Move forward under situation of bucket touching the ground slightly. Drive the machine down to ground from the plate. Necessary measures should be taken to avoid the road being scratched.

# Truck transportation

## Lifting



### Attention

- \* The machine can not be lifted when there are persons inside it.
- \* The wirerope should have enough strength to lift the machine.

Follow the steps below when lift the machine.

1. Revolve the upper part of the machine to make the dozer blade opposite collinear to the work device.
2. Uplift the dozer blade to the limit height.
3. Uplift the boom to draw back the bucket and the arm to the most extent. Then put operating handle lock rod to "Locked".
4. Put the swing pedal to default position (do not swing the boom). Close the pedal cover and shut off the engine.
5. Assemble rings to the 2 lifting holes in the two sides of the dozer blade. Tie wirerope through the rings and the location of the boom as shown in the figure.

Refer to the following figure to determine the length of the wirerope.

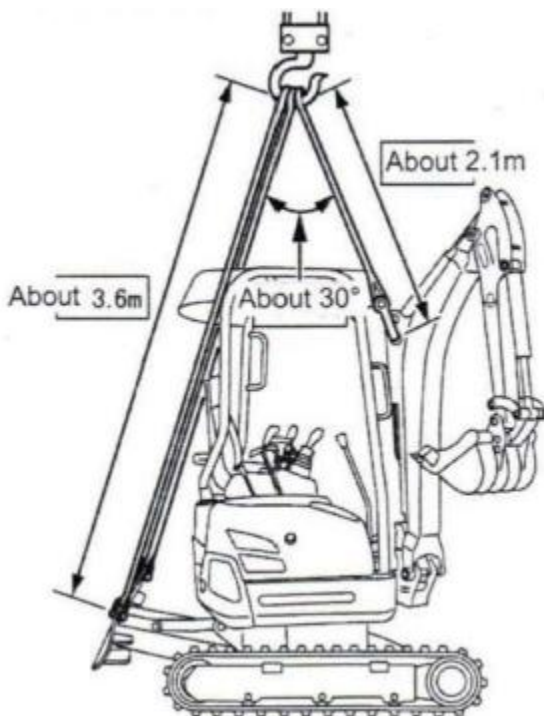

## Supplement

- \* Keep balance during lifting process.
- \* Do not lift when the boom swings or the upper part of the machine revolves.

## Traction



### Attention

- \* The wirerope should have enough strength. In addition, verify that there is no breakages or cracks in the wirerope.

As shown in the figure, pull out the machine with wirerope if it is stuck by muddy place.

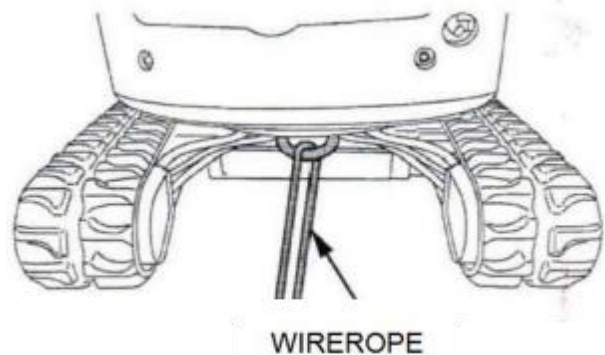

# Maintenance



## Attention

\* When refuel or maintain the machine,  
 1. Park the machine on a flat and capacious place.  
 2. Put the bucket and dozer blade down to the ground.  
 3. Shut off the engine.  
 4. Operate operating handles of work device and dozer blade to verify that residual stress has been released.  
 5. Pull out the start key. Maintain after safety verification.  
 Maintain the machine after carefully read "Cautions in maintenance" in yellow pages.

## Rejectamenta disposal



## Warning

Environment would be polluted by the castoff. Environmental pollution behaviors would be punished according to laws. So do not throw away and incinerate castoff at random.  
 Dispose the castoff properly:  
 \* Gather effluent exhausted from the machine to a container.  
 \* Do not exhaust the effluent to the ground or pour into rivers, lakes or seas.  
 \* Refer to the dealer or related organization to throw away or incinerate castoff (waste oil, fuel, coolant, antifreeze fluid, solvent, filter, battery, rubber or other waste material).

## Cautions in excavator washing

Human injuries, machine damage and breakdown would be caused by improper washing measures with high-pressure washer. Use the washer correctly according to the instructions and labels.



## Attention

To ensure the machine not be damaged during washing, wash the machine with dispersive water and keep off it at least 2 m.  
 If spray water directly or wash closely,  
 1. The wire wrapper would be damaged and fire may be caused.  
 2. Injuries may be caused by high pressure hydraulic oil if the hosepipe is damaged.  
 3. Damage and breakdown would be caused.  
 e.g. 1) seals and labels falling off  
 2) breakdown of electronic components, engine and safe cab caused by watering.  
 3) damage of tyres, seals, resinous parts and glasses  
 4) paint and coating falling off

Do not wash the machine with directly spraying water

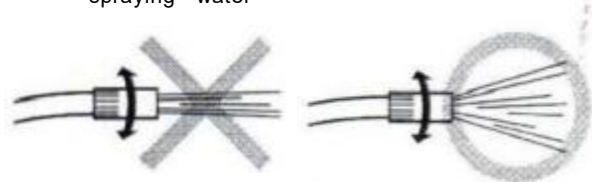

spraying water directly

dispersive watering

Do not wash the machine closely

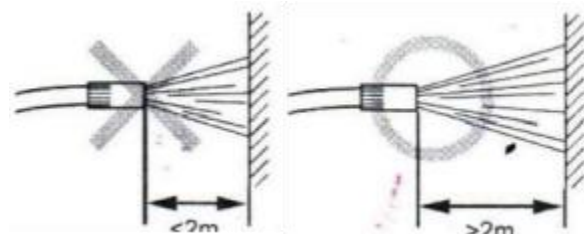

# Maintenance

## Periodic check list

No.	Date		quantity	Time showed by hour meter																Thereafter	Reference Page
	Items			500	1000	1500	2000	2500	3000	3500	4000	4500	5000	5500	6000	6500	7000	7500	8000		
1	bucket pin	Inject grease	4																	Daily	42
2	swing fulcrum pin	Inject grease	2																	Daily	42
3	boom root pin	Inject grease	1																	Daily	42
4	boom oil cylinder boss	Inject grease	2																	Daily	42
5	fuel	Water draining	1	0	0	0	0	0	0	0	0	0	0	0	0	0	0	0	0	Every 50h	43
6	battery diluent	Check	1	0	0		0	0	0	0	0	0	0	0	0	0	0	0	0	Every 50h	44
7	bearing gear root	Inject grease	1	0	0	0	0	0	0	0	0	0	0	0	0	0	0	0	0	Every 50h	45
8	gear oil of terminal drive gearbox	Replace	2		0										0					Every 500h	46
9	fan belt	Check Adjust	1				0				0				0				0	Every 200h	46
10	air filter core	Clean Check	1				0				0				0				0	Every 200h	47
		Replace	1																	Every 1000h or 1 year	52
11	bearing balls	Inject grease	1				0				0				0				0	Every 200h	47
12	radiator hosepipe and clamps	Check	2				0				0				0				0	Every 200h	47
		Replace	2																	Every 2 years	54
13	working device	Inject grease	10					0					0						0	Every 250h	50
14	engine oil (level CF)	Replace	1	◎					0					0					0	Every 250h	48
15	engine oil filter core	Replace	1	0					0					0					0	Every 250h	49
16	hydraulic oil return filter ☆	Replace	1					◎											0	Every 500h	49
17	fuel filter core	Replace	1										0							Every 500h	50
18	hydraulic oil ☆	Replace	1																	Every 1000h	50
19	hydraulic oil sucking filter core	Replace	1																	Every 1000h	50
20	hydraulic oil pilot return filter	Wash	2																	Every 1000h	51

No.	Items	Date	qua ntity	Time showed by hour meter																Thereafter	Reference Page
				5 0	1 0	1 5	2 0	2 5	3 0	3 5	4 0	4 5	5 0	5 5	6 0	6 5	7 0	7 5	8 0		
21	grease of track roller and front idler	Replace	8																	Every 2000h	52
22	alternator, starting motor	Check																		Every 2000h	52
23	wire harness fuse	Check																		Every 1 year	52
24	Icoolant	Replace	1																	Every 2 years	53

- (1) ©: This symbol means only implement this item at the first time.
- (2) ☆: This symbol means that the change period would be shortened if hydraulic hammer is used.  
(Details refer to Chapter "Change hydraulic oil return filter")
- (3) Engine oil consumes gradually due to the running of the engine. The consumption depends on the work content, the engine and other conditions. Verify that the engine oil volume is at the range between upper and lower limit of the oil level mark and add oil if necessary before work. In order to avoid engine life being shortened and cylinder burning-out, please use Kubota engine oil and filter and change engine oil at specified time

# Maintenance

## Daily maintenance

### Grease injection for bucket pin

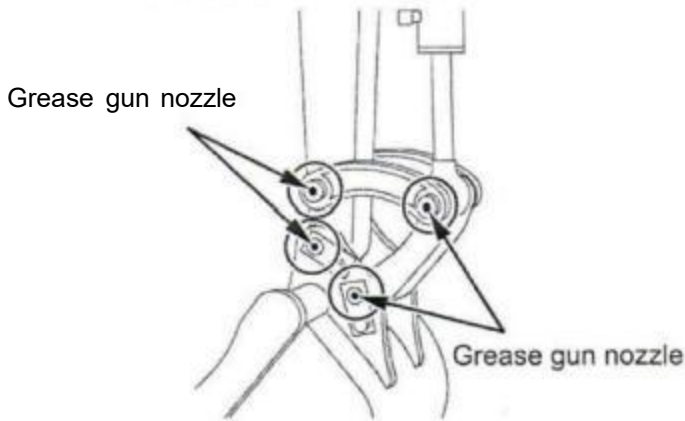

Inject grease into grease gun nozzle, then operate the bucket several times. Inject grease again afterward

### Grease injection for swing fulcrum pin

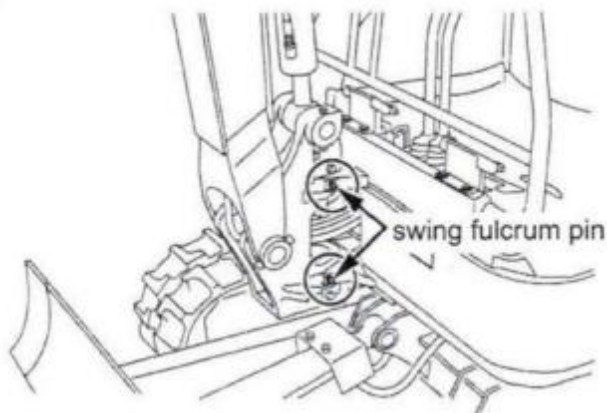

### Grease injection for boom root pin

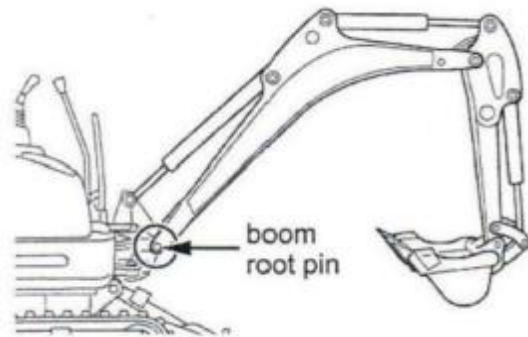

### Grease injection for boom oil cylinder boss

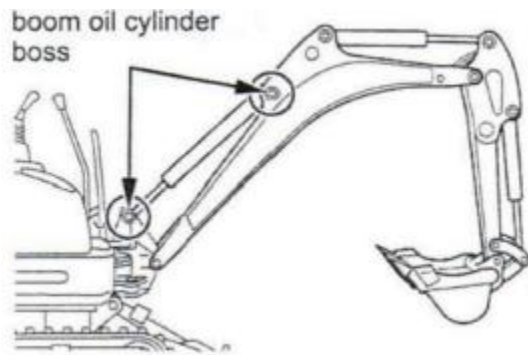

### Grease injection for working device

Inject grease into grease gun nozzle.

- (1) Arm root pin .....1 place
- (2) Arm oil cylinder boss .....2 places
- (3) Bucket oil cylinder boss ... ..1 place
- (4) Swing oil cylinder boss .....2 places
- (5) Dozer blade oil cylinder boss .....2 places
- (6) Dozer blade root pin.....2 places

### Important

- \* Inject grease sufficiently before work in water and inject grease immediately after in water.
- \* Inject grease after high-pressure washing.
- \* Inject grease when sounds appear in pins during working.
- \* Inject grease before deep and heavy excavating work.

## Maintenance after working per 50h

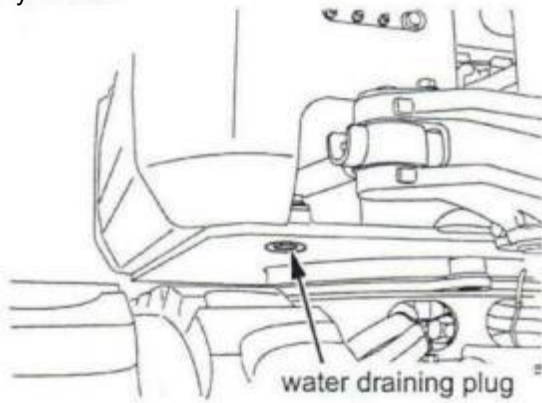
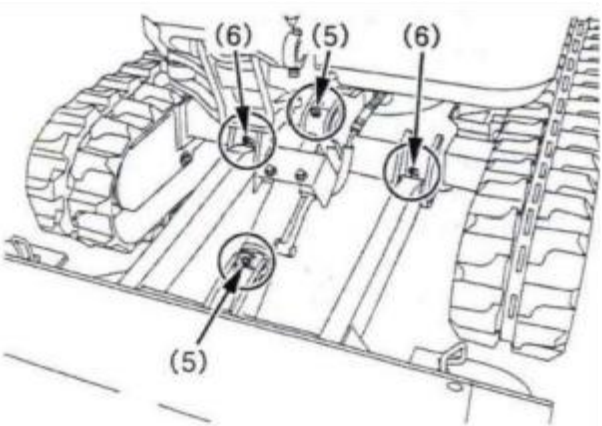
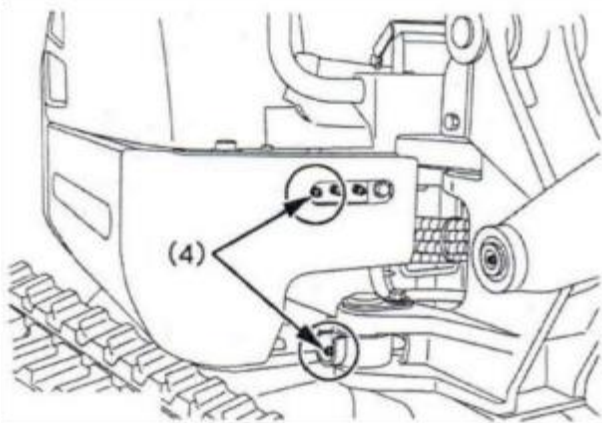
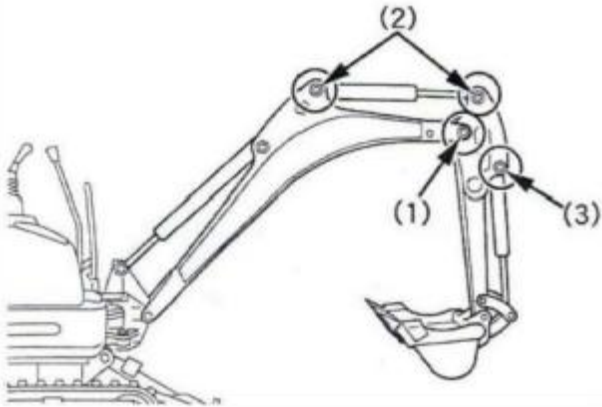

### Water drainina from fuel container

#### ◆ Fuel container

Remove the water draining plug from the bottom of fuel container (under the rotating frame) to drain away water.

#### ◆ Water separator

The red float floats up when water exists in the oil cup. Put the water separator handle to "CLOSE", and loosen the fixed ring, and disassemble the oil cup, then remove water.

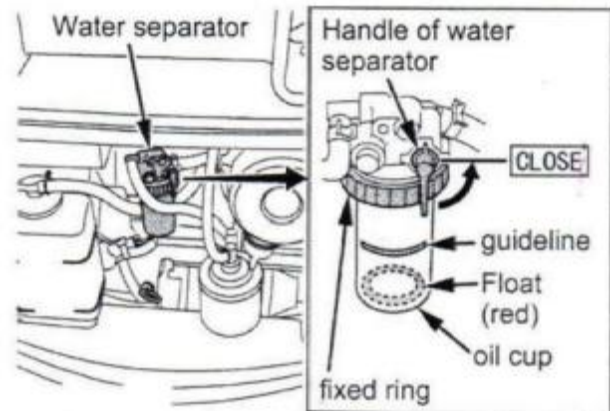

### Important

\*Keep off chippings and dust when assemble the water separator.

\*Make sure operate the machine after air is exhausted from fuel system.(Refer to Chapter "Exhausting of fuel system" of "Maintenance")

\* If the water separator is Fleetguard brand ffrom Shanghai, please check and wash'the separator according the directions.

# Maintenance

Check storage battery diluent level



## Danger

There are two types of storage battery: one don't need to add water, the other need to add water. Comply the following items for the battery need to add water:

- \* Do not use and charge the battery when battery diluent at LOWER level(minimum level).
  - \* Battery life would be shortened or explosion may be cause when using the battery with battery diluent under the LOWER level.
- Add diluent to the range between UPPER level and LOWER level(if the battery can add water).

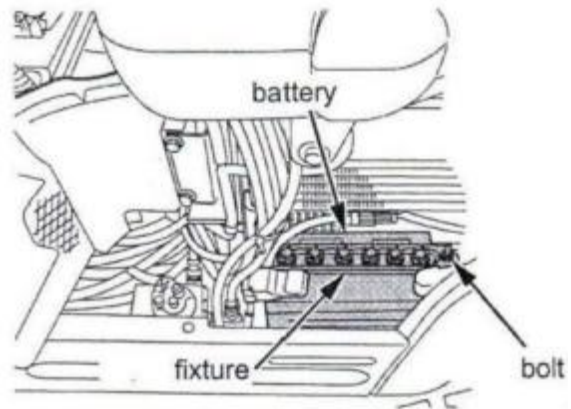

battery diluent level

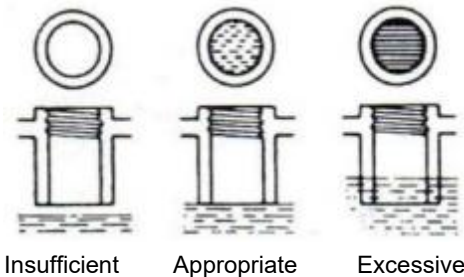

## Warning

- \* Keep off the battery diluent from human body or clothes . Clean with water if skin or clothes are attached the diluent . Burn injury may be caused by dilute sulphuric acid due to carelessness .
- \* Shut off the engine and turn the start key to "Off" when check or disassemble the battery.
- \* Keep off the battery from fire in case of explosion during charging . Remove all the diluent orifice plugs before charge the battery.
- \* Wear glasses to protect your eyes when work close the battery.

### Disassemble steps of the battery

1. Shut off the engine and tum the start key to "Off".
  2. Disassemble the wire from the(-)pole.
  3. Disassemble the wire from the(+)pole.
  4. Disassemble the 4 bolts from the left battery cover.
  5. Disassemble the nuts, and disassemble the fixture.
- Disassemble the battery.

1. Open the back bonnet, and then the battery can be seen.
2. Remove battery cover. Add diluent or distilled water if it is insufficient.
3. Purchase diluent of the same concentration from a speciality store. Add the diluent timely.
4. Sweep the air vent of the battery cover.



### Attention

\* When charge the battery, make sure disassemble the battery from the machine and charge it at well ventilated place.

\*Disassemble the battery wire from(-)pole firstly, while assemble it from (+)pole firstly. If not, short-circuit would be caused by touching metal of the wire.

\* Connect the(+) pole of the battery to the(+) pole of the charger, and connect the(-)pole of the battery to the(-)pole of the charger. Do not mis-connect the wires.

Do not charge the battery with(+)and(-) poles connected to the wires from the machine.

\* Electric spark and breakdown may be caused if any terminal is loose. Fix the terminals firmly. \* Remove the ordure and dust before open the battery cover to add battery diluent or distilled water

### Important

\* The battery would be damaged due to insufficient battery diluent. While the metal parts would be corroded by exceeded diluent.

\* Wire harness may also be damaged except electronic components.As far as possible to avoid quick-charging. If not, battery life would be shortened.

\* Do not mis-connect the wires to(+)and(-)poles in case of battery and electrical system breakdowns.

### Grease injection for bearing gear root

1. Inject grease from grease gun nozzle as shown in the figure.
2. Revolve it at each intervals of  $90^{\circ}$  .Inject grease by 4 times.
3. Inject about 50g grease in each place by grease gun. Inject grease to the whole gear root surface.



# Maintenance

## Maintenance after working per 100h

Maintain at the same time also after work per 50h.

Gear oil change for terminal drive gearbox  
(1st after 100h, then per 500h)

1. Revolve the crawler frame to lower the oil draining bolt of the terminal drive gearbox.
2. Remove oil draining bolt to drain the oil.
3. After tighten oil draining bolt, remove oil check and add port plug. Add gear oil from the oil port.
4. The specified volume of oil is shown below.

The specified volume of oil for terminal drive gearbox	About 0.25L
--	-------------

Inject gear oil until it outflows. Tighten the plug afterwards.

5. Please use SAE#90 type gear oil.  
(Please refer to the Chapter "The recommended lubricating grease")

oil check and add port plug

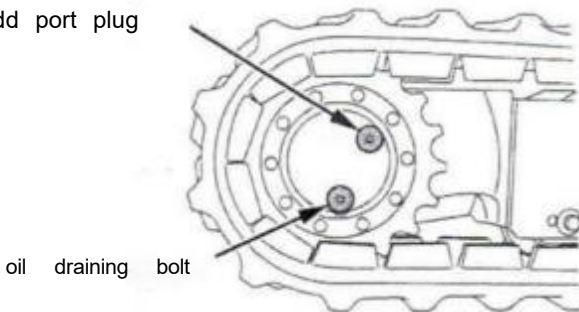

## Maintenance after working per 200h

Maintain at the same time also after work per 50h and 100h.

Check and tensioning the fan belt



### Attention

- \* Shut off the engine before adjust the fan belt. If not, hand injury may be caused by fan scratching.

1. Press the central part of the fan belt with the force of 98N(about 10kgf). If a deflection of 7mm is caused by the force, it means that tensioning degree of the belt is appropriate.

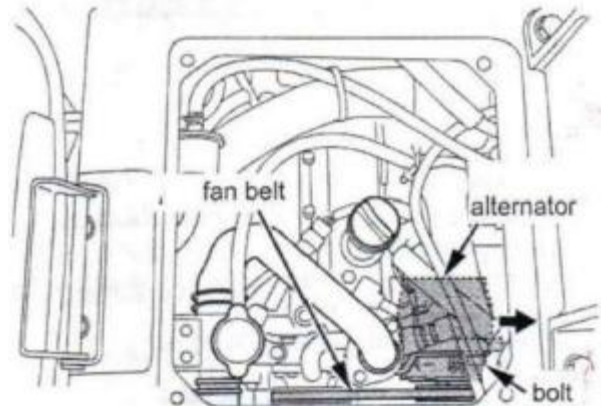

2. Check the abrasion conditions of all belt pulleys, V-groove and v-belt. Especially check whether the V-belt touches the bottom of the groove.
3. Replace the belt when it is lengthened, can not be adjusted, is scratched or fractures.

### Important

- \* Slipping may appear when the tensioning force is too little, which not only reduces the engine capacity, but also shortens its service life. Make sure check and adjust it.
- \* The battery charging light turns on when the fan belt fractures. Shut off the engine **at this** time.

Check and sweep the air filter



## Attention

\* Dust flying would be caused by sweeping with compressed air. Therefore, please wear protective glasses firstly. Sweep and check as early as possible when work in dusty place.

Remove the clamp and put out the outer filter. Install the outer filter after the outer filter and shell inside are swept. Do not disassemble the inner filter.

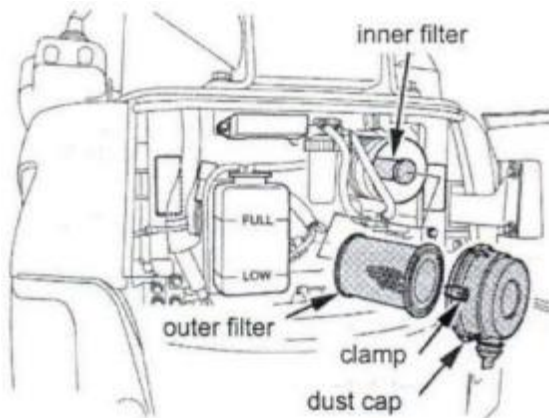

### ◆ Sweep steps

Sweep the dust on the filter outside roughly with dry compressed air (0.49 MPa, 5 kgf/cm<sup>2</sup>). Then sweep all the dust from inside to outside.



Grease injection for bearing balls

1. Inject grease from grease gun nozzle as shown in the figure. (The middle grease gun nozzle)
2. Revolve it at each interval of 90°. Inject grease by 4 times.

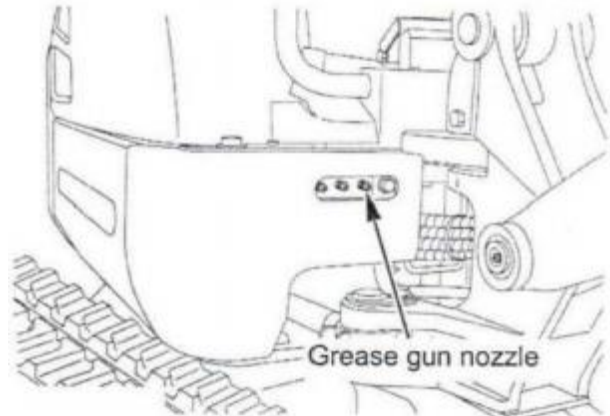

Check the radiator hosepipe

Check the fastening of radiator hosepipe after work every 200h or 6 months.

1. Tighten the clamps when it is loose or leaks.
2. Replace and tighten the clamps when radiator hosepipe inflates, hardens or crazes.

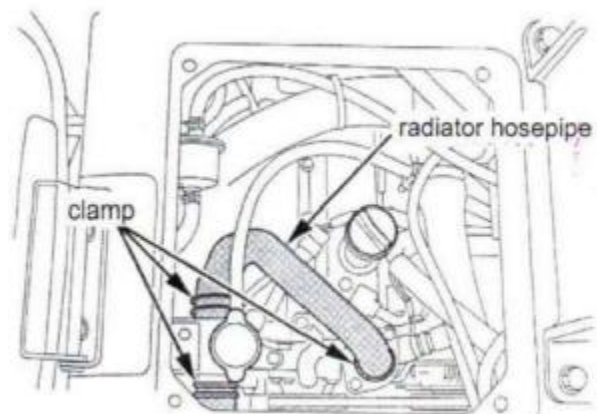

# Maintenance

Maintenance after working per 250h

Maintain at the same time also after work per 50h.

Change engine oil(1st after 50h, then per 250h)

1. Remove oil draining bolt from the bottom of the engine to drain the oil.
2. Tighten oil draining bolt after oil has drained.

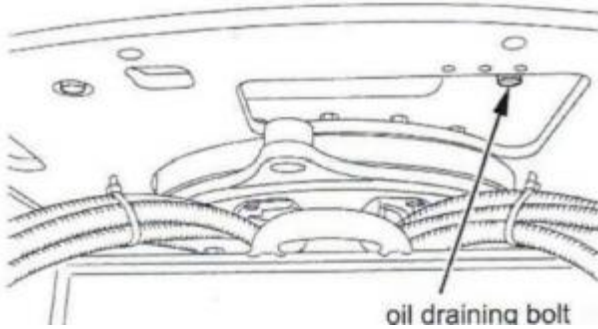

3. Put down the seat forward and remove the cover used in check.
4. Add specified volume engine oil from the oil port .

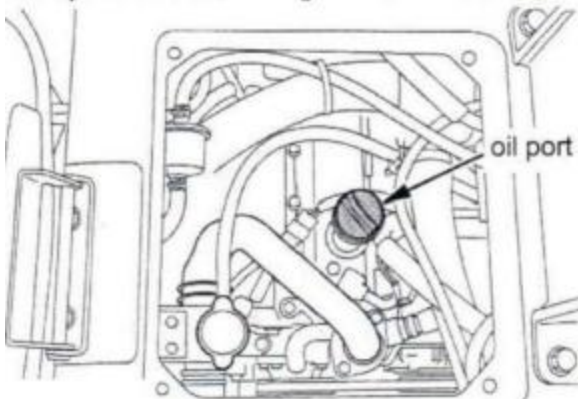

- Keep the engine idling running and then shut off
5. the engine .5min later, Check the oil level mark and verify enough engine oil has been added.

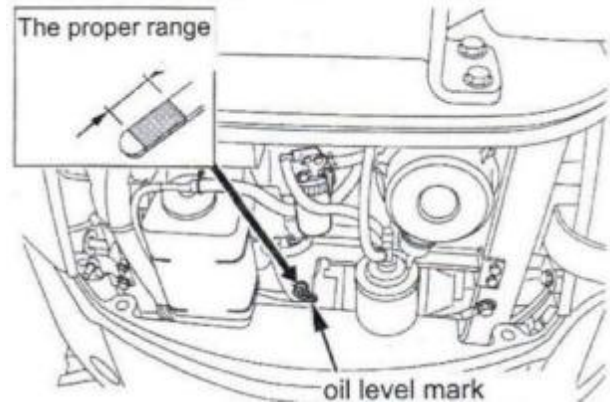

## Supplement

Engine oil volume	about 3.5L(include filter)
-------------------	----------------------------

- \* Use the recommend grease in Chapter"The recommend grease".
- \* Change the engine oil half a year no matter how long the machine works.

Change engine oil filter core(1st after 50h, then per 250h)

1. Change engine oil at the same time.
2. 12. Disassemble the filter core with filter spanner.

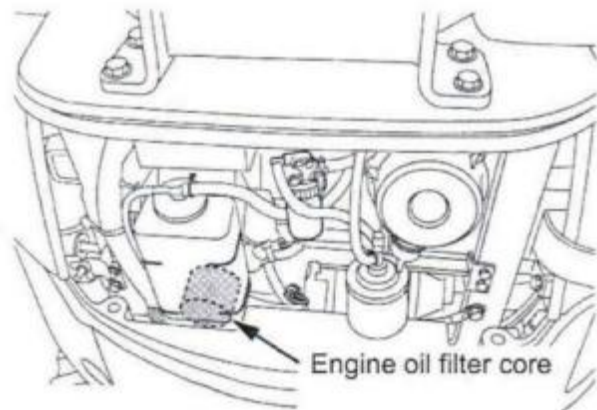

3. Daub a layer of engine oil on the O-shape ring of the new filter. Tighten it with your hands (instead of filter spanner) afterwards.
4. Add engine oil to the specified volume.
5. Keep the engine runs for about 5 min. Shut off the engine after verify no abnormalities exists with the engine oil light.
6. Verify the oil volume with oil level mark again. Add engine oil when it is insufficient.

Change hydraulic oil return filter(1st after 250h, then per 500h)

Refer to the dealer or assigned repair factory by the manufacturer.

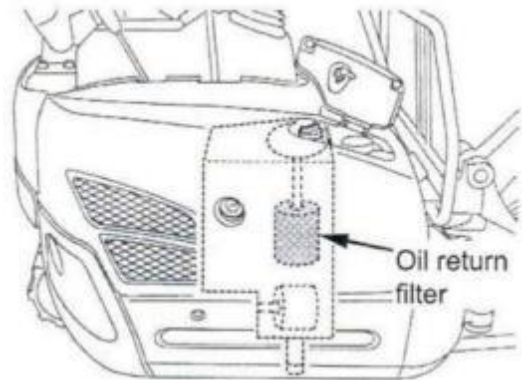

### Important

\* The change period would be different if hydraulic hammer is used. Change oil return filter according to the using frequency from the following table.

Time ratio of the use of hydraulic hammer	Change period of hydraulic oil	Change period of oil return filter
Standard work (backacting)	per 1000h	per 500h (First 250h)
Ratio 20%	per 800h	per 200h
40%	per 400h	
60%	per 300h	per 100h
more than 80%	per 200h	

### Supplement

\* Make sure check the olevel after replace the filter.

# Maintenance

## Maintenance after working per 500h

Maintain at the same time also after work per 50, 100,250h.

### Change fuel filter core

1. Disassemble the fuel filter core with filter spanner.
2. Tighten the new filter core with your hands

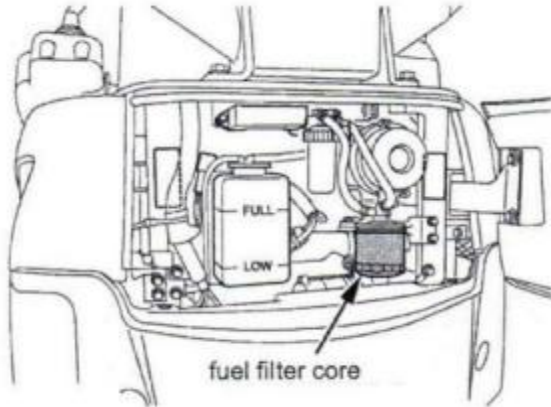

### **Important**

- \* Keep off dust during assembling the filter.
- \* Exhaust air after replace the filter core.(Refer to Chapter "Exhausting of fuel system")

Gear oil change for terminal drive gearbox (1st after 100h, then per 500h)

The change of gear oil refer to Chapter "Maintenance after working per 100h".

Change hydraulic oil return filter(1st after 250h, then per 500h)

The change of hydraulic oil return filter refer to Chapter "Maintenance after working per 250h".

## Maintenance after working per 1000h

Maintain at the same time also after work per 50, 100,200,250,500h.

Change hydraulic oil(change the sucking filter core at the same time)

1. Adjust wheel track to the maximum(1240 mm).
2. Park the machine in a flat place. Put the working device in the middle. Draw back the arm and bucket to the most. Put the bucket and dozer blade down to the ground.

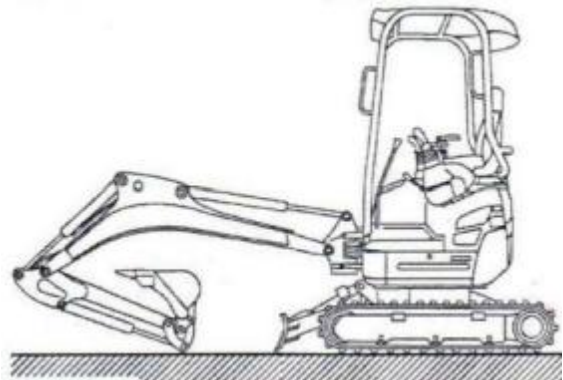

3. Remove the oil draining bolt from the bottom of the oil tank. Drain the hydraulic oil.

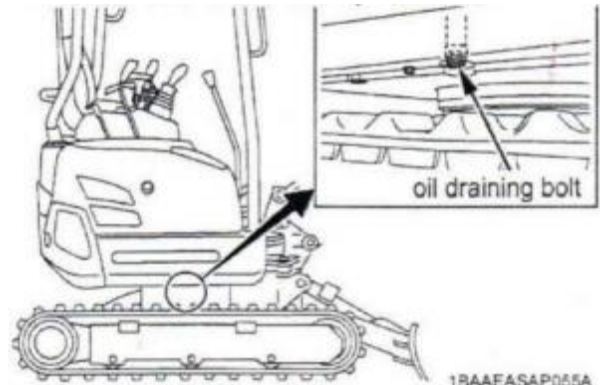

4. 1 Remove the cover from hydraulic oil tank.
5. Disassemble the oil sucking filter core with filter spanner.

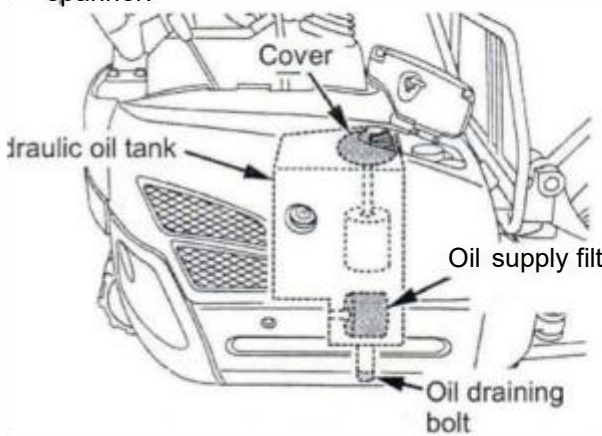

Change hydraulic pilot return filter  
 There are dust and dirt exist in the concave of the filter.  
 Wash the convex with spraying engine oil.

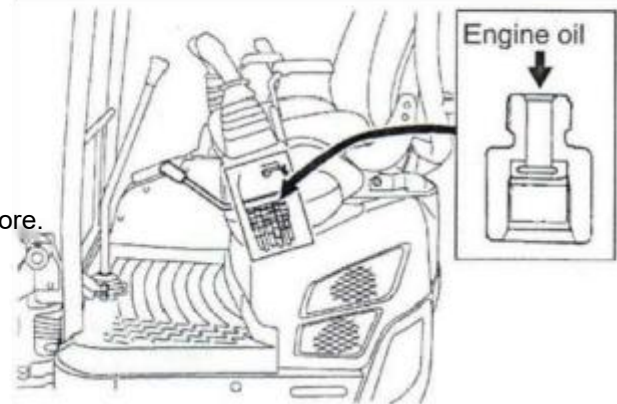

6. Tighten the oil draining bolt.
7. Add specified volume of hydraulic oil .
8. Keep the engine idling running for about 5 min and then shut off the engine . Verify enough engine oil has been added.

Change volume of hydraulic oil	Total volume	21L
	Oil tank volume	13L

### Supplement

- \* Wash the inner surface of the oil tank when sediment exists.
- \*Keep impurities off from the inside of the oil tank.
- \* Refer to the dealer or assigned repair factory to change the oil sucking filter core .

# Maintenance

## Maintenance after working per 1000h or 1 year

Change the air filter  
Remove the clamp and put out cores of the outer filter and inner filter. Install them again after replace to new ones

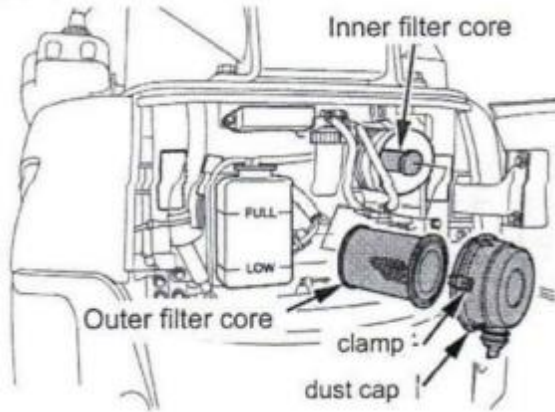

## Maintenance after working per 2000h

Maintain at the same time also after work per 50, 200,250,500,1000h.

Change grease of track roller and front idler  
Refer to the dealer or assigned repair factory.

Check the alternator and starting motor  
Refer to the dealer or assigned repair factory.

## Maintenance after working per year

### Check the wires and the use offuse



### Attention

- \* The damaged harness and wires of battery would cause short-circuit. Make sure check them.
- \* Fire may be caused by attached ordure or fuel on battery, wires, muffler and engine. Check them daily before work.

Poor contact would be caused if wire harness terminal is loose. Not only the performance of electronic components would be damaged, but also short-circuit, electric leakage or fire may be caused sometimes by the damaged wire harness. Therefore, replace or repair the damaged wire harness as soon as possible.

### **important**

- \* When it blows immediately even if the fuse is replaced, please do not use other metal wire replace the fuse. Repair the machine in the dealer or assigned repair factory immediately.
- \* The wire harness have the performance of waterproofness. Please do not repair it at random, but refer to the dealer or assigned repair factory.

## Maintenance after working every 2 year

### Change coolant (long-acting coolant)



#### Attention

\*Make sure open the radiator cover after the radiator cools completely in case of burn by steam or hot water.

1. Remove radiator cover, then remove the water draining plug to drain all the coolant. Remove the auxiliary water tank and its cover to drain water from the auxiliary water tank.
2. Add water at the same time during water draining until clean water flows out.
3. Tighten the water draining plug and add long-acting coolant into the radiator and auxiliary water tank. Tighten the radiator cover and start the engine. Keep the engine idling running for about 5 min and then shut off the engine. Verify enough coolant has been added.

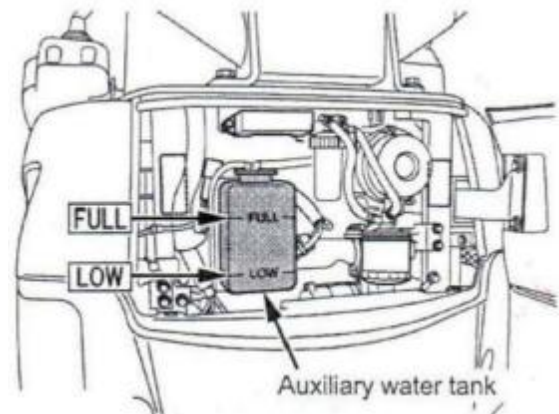
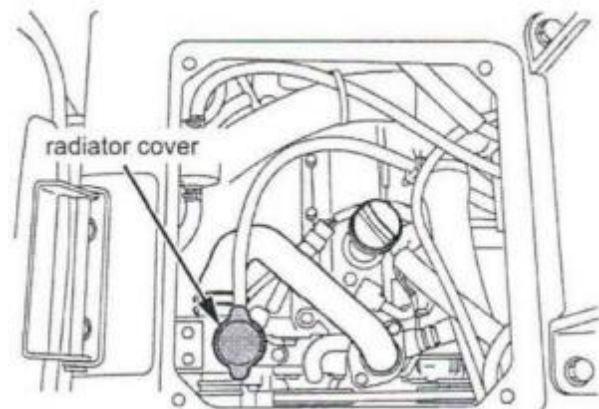
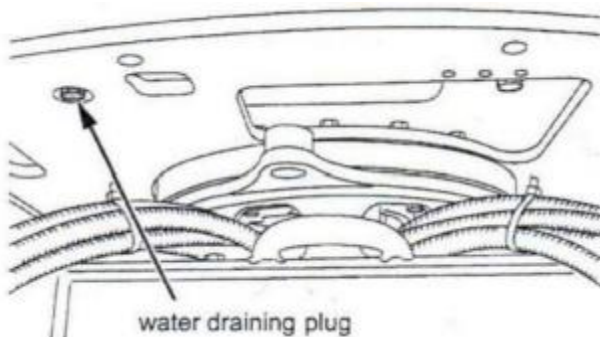

#### How to use antifreeze fluid (except conditions of long-acting coolant)

The antifreeze fluid can decrease freezing point, so the damage of oil cylinder and radiator can be prevented by unfreezing of the coolant.

Make sure mix the long-acting antifreeze fluid (Type PT) with clean water and add it into the radiator and auxiliary water tank when air temperature is below 0 °C.

#### **Important**

\* The mixing ratio of antifreeze fluid varies according to the manufacturers and air temperature. Mix it according to the mixing ratio stated in Chapter "Safeguard procedures at low temperature".

\* Do not mix the antifreeze fluid of different manufacturers.

Coolant	about 2.7L(0.6L in auxiliary water tank)
---------	--

# Maintenance

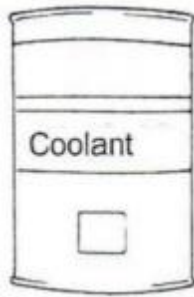

- \* Antifreeze fluid-----the valid period of the long-acting coolant is 2 years .
- \* If the used coolant is not long-acting coolant, please change it in spring and autumn respectively every year.

## Supplement

- \* Long-acting coolant had been add when the machine leaved factory.(mixing ratio: antifreeze fluid 50% ,water 50%)

Change radiator hosepipe and clamp



## Attention

The radiator hosepipe and clamps may fracture when they serves too long time, which may lead to water erupting and cause burn injuries. Therefore, replace them as soon as possible.

Replace the radiator hosepipe and clamps every 2 years. Replace them also when radiator hosepipe inflates, hardens or crazes.

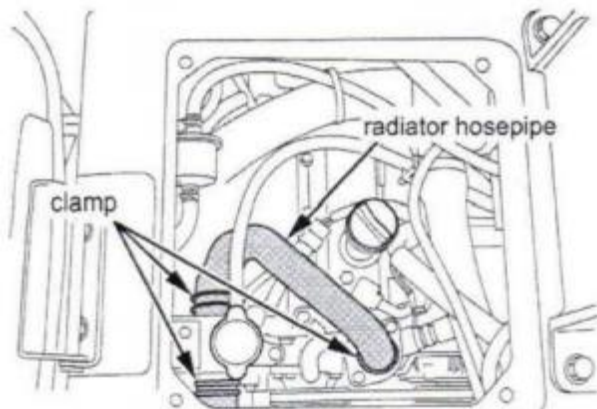

## Check and the use of storage battery



## Warning

- \* Disassemble the battery wire from(-)pole firstly, while assemble it from (+) pole firstly.If not, short-circuit would be caused.
- \* Hydrogen exist in the inside of battery.Keep off the battery from fire in case of explosion. Remove all the diluent orifice plugs before charge the battery.
- \* Do not put metals or combustibile material around the battery. Explosion and fire may be caused by short-circuit. Blindness and burn may be caused by battery diluent(dilute sulphuric acid). Clean with water if skin or clothes are attached the diluent. Wash with water then go to hospital if eyes are attached the diluent.
- \* Make sure remove all the diluent orifice plugs before charge the battery.
- \* Wear glasses to protect your eyes when work close the battery.

Check and use the battery when the engine is shut off and the start key at "OFF" positon.

## Battery maintenance

Battery life would be shortened if it is misused, which causes unnecessary spending. Therefore, in order to deliver the battery performance sufficiently, please use the battery correctly.

1. The battery is an necessary part, which plays a role as starting power supply and indicator power supply.
2. The engine could not be started and the the ight turns dim when the stored energy in battery is low. It may be too late to charge the battery. Therefore, charge the battery as early as possible.
3. Battery diluent reduces because of water evaporation. The battery would be damaged due to insufficient battery diluent. While the metal parts would be corroded by exceeded diluent.
4. Check that whether the polar plate has exposed.Add diluent or distilled water into the battery when the diluent is insufficient.

5. When preserve the machine for long time, please disassemble the battery from the machine and charge it. Adjust the battery diluent level correctly and conserve it from light in a dry place.

6. Battery energy runs away naturally in preserve condition. Please charge the battery monthly.

7. Remove the ordure and dust before open the battery cover to add battery diluent or distilled

### Cautions in charging

1. Make sure turn the start key to "Off" and disassemble the battery from the machine when charge the battery.
2. The battery would be damaged due to insufficient battery diluent. While the metal parts would be corroded by exceeded diluent.
3. Try to avoid quick charging. Battery life would be shortened by quick charging.
4. The battery only can be quick charged in emergency.
5. Do not mis-connect the wires to(+) and(-) poles. Battery and electric system breakdowns would be caused by mis-connect.
6. Disassemble the battery wire from(-)pole firstly, while assemble it from (+) pole firstly. If not, short-circuit would be caused by touching metal of the wire.
7. When charge the battery, connect the(+)pole of the battery to the(+)pole of the charger, and connect the(-)pole of the battery to the(-)pole of the charger.
8. Disassemble the wires connected to the battery when use the battery on occasions except check and measure battery ratio.
9. Remove all the diluent orifice plugs.

Check the battery diluent level

Refer to the Chapter "Maintenance after working per 50h".

Cautions in charging when the battery is on machine (only in emergency)

Charge the battery after it is disassembled from the machine.

1. Insert the starting key and turn it to "STOP" and disassemble the wire harness of battery(-)pole, then charge it.
2. Make sure remove all the diluent orifice plugs to exhaust the gas before charge the battery.
3. Stop charging when the battery overheats(liquid temperature exceeds 45 °C ).
4. Stop charging immediately when the battery is fully charged. If continue charge, it may lead to:
  - battery overheat
  - battery diluent decrease
  - poor conditions of the battery
5. Do not mis-connect the wires to(+) and(-)poles. The alternator would be damaged by mis-connect.
6. Charge the battery complementarily according to the instructions of the charger after start the engine and work according to the methods above. If the battery is not charged complementarily, battery life would be seriously shortened.

# Maintenance

Start the engine use emergency wire

1. The battery produces flammable gas. Keep off the battery from fire and spark in case of explosion.

Therefore, try not to start the engine use emergency cable.

2. Replace a new one as early as possible when the battery life expires.

When start the engine with emergency cable, follow the steps below in case of accidents.

◆ Before connect to the battery

1. The capacity of the emergency cable should coincide with the battery.
2. Does the terminals of emergency cable, clip, battery(+) and(-) poles fracture or corrode?
3. Is the start key at "Off"?
4. The battery capacity of the normal vehicle should be the same to the broken-down vehicle.

◆ Connection of emergency cable

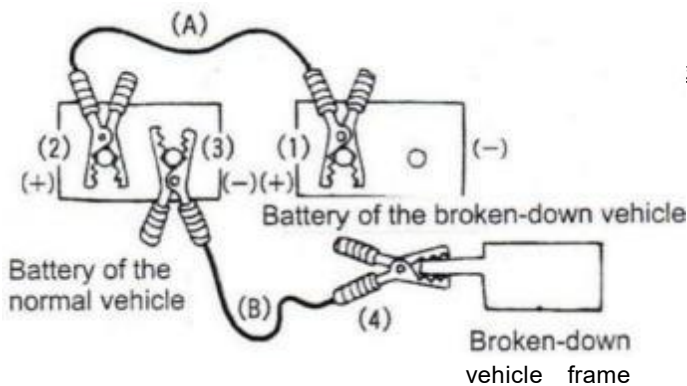

1. (1) Connect a clip of emergency cable (A) to the (+) pole terminal of the broken-down vehicle. (2) Connect the other clip to the (+) pole terminal of the normal vehicle.
2. (3) Connect a clip of emergency cable (B) to the (-) pole terminal of the normal vehicle. (4) Connect the other clip to the frame of the broken-down vehicle.

\*Do not keep the battery too close with the vehicle body

3. Make sure connect all terminals firmly before start the engine.

◆ Start the engine of broken-down vehicle

1. Start the engine after all terminals have been connected.
2. Restart again after 2~3 min if the engine is failed to start.

◆ Disassemble of emergency cable

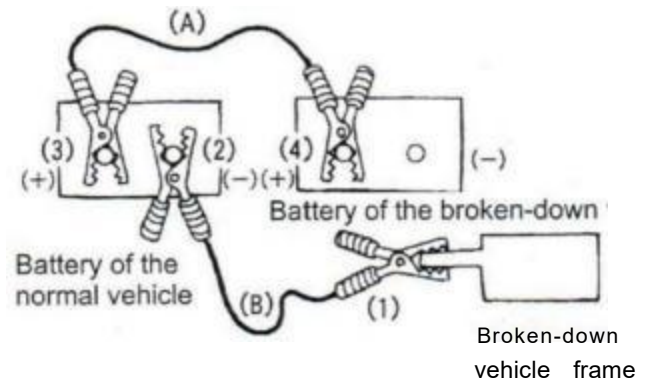

1. (1) Remove the clip of emergency cable (B) from the frame of the broken-down vehicle. (2) Disconnect the other clip to the (-) pole terminal of the normal vehicle.
2. (3) Remove the clip of emergency cable (A) from the (+) pole terminal of the normal vehicle. (4) Disconnect the other clip to the (+) pole terminal of the broken-down vehicle.

## Cautions in engine starting and battery charging

If battery power has exhausted, start the engine and use the battery follows the steps below.

### **Important**

- \* Prohibits in charging and starting with power exhausted battery (if too large voltage is applied to the electronic components such as controller and electric meters), damage may be caused. Be cautious in maintenance.
- Do not start the engine with 24V working voltage. Make sure start the engine with 12V voltage.
- Do not charge the battery with the terminals on the battery. Remove the terminals before charge the battery.
- Do not start the engine with the charger.
- Do not start the engine with 24V battery. Make sure start the engine with battery of 12V.
- Do not remove the battery terminals during engine running.

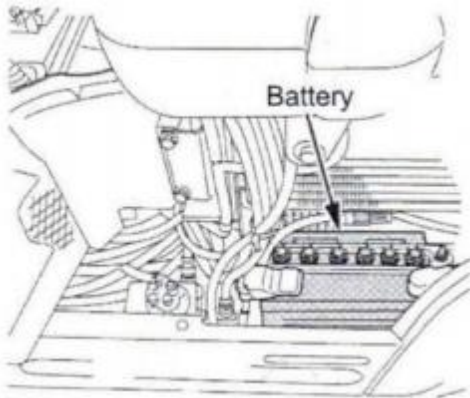

## About fuse



### **Attention**

- \* Make sure turn the start key to "STOP" and shut off the engine when replace the fuse or slow-blow fuse. If not, electric spark would be produced, which may cause danger.

## Change the fuse

Turn the starting key to "Off".

Open the back bonnet and remove the fuse box.

Replace the same capacity fuse with the fuse clamp.

### **Important**

- \* When it blows immediately even if the fuse is replaced, please do not use other metal wire replace the fuse. Repair the machine in the dealer or assigned repair factory immediately.

## The location of fuse box

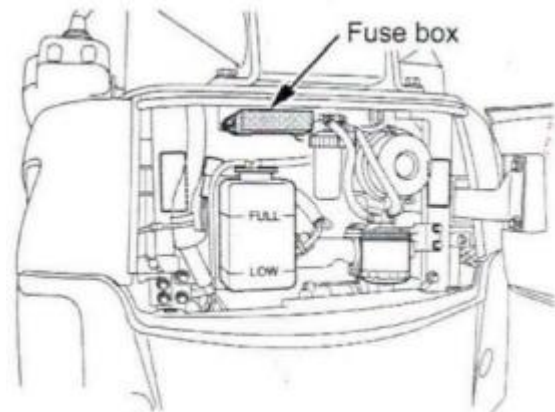

# Maintenance

The capacity of fuse and circuit

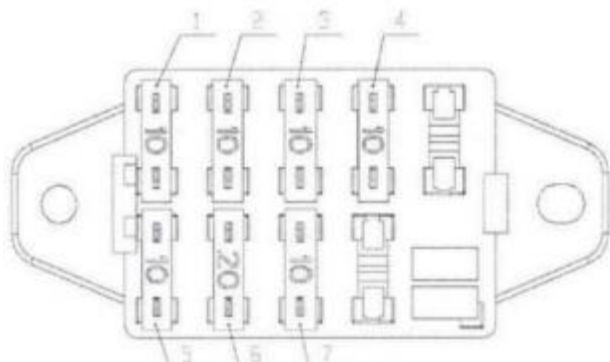

NO.	Fuse capacity	The applied circuit
1	10A	power supply of electric meters
2	10A	power supply of oil outage
3	10A	double speed power supply
4	10A	power supply of safe lock
5	10A	hybrid power supply
6	20A	power supply of working lights
7	10A	power supply of the horn

Change slow-blow fuse

The slow-blow fuse is used to protect the wire harness. Make sure find out the reason when the fuse blows. Do not use other material replace the fuse.

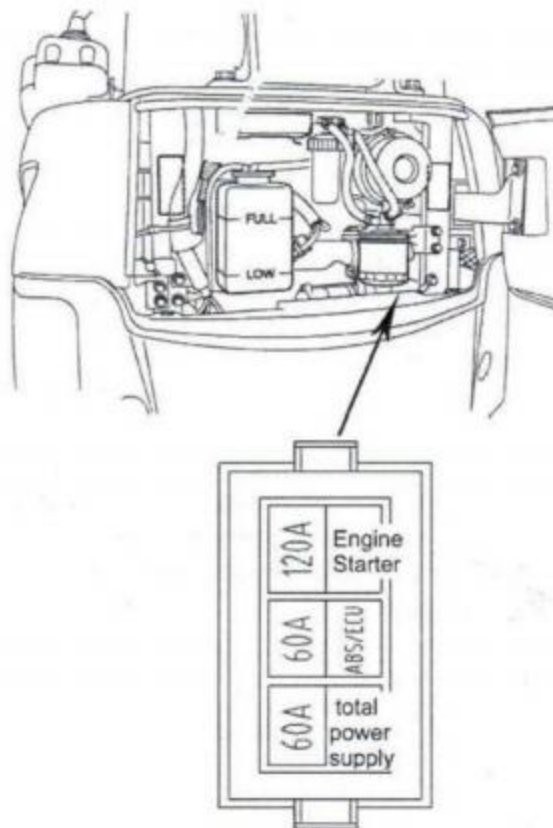

## Exhausting of fuel system

1. Add fuel into the fuel container .
2. Insert the start key into switch and turn it to" ON".

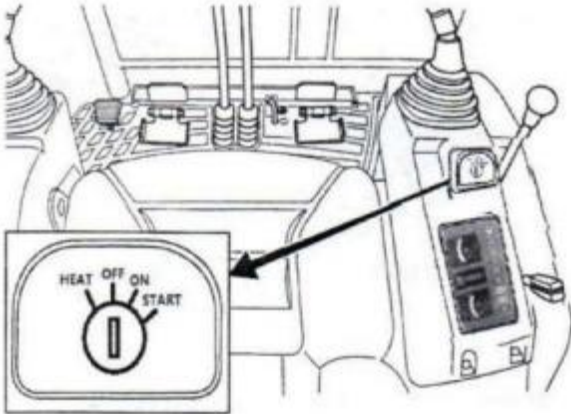

3. Exhaust air automatically for about 1 min.

### Supplement

- \* Air can not be exhausted completely for one time. Start the engine and then shut off it. Repeat step 2 and 3 above.

## Crawler adjustment

### Tensioning the rubber crawler

1. Insert grease gun into the nozzle to inject grease.

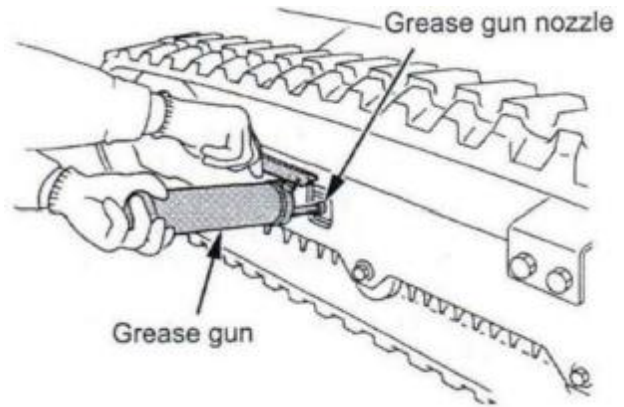

2. The figure shows the tension degree of the crawler. Adjust size(A)(the gap between middle track roller outside and upper surface of the crawler)to 10~15mm at the state of crawler hanging in air.(The commissure of the crawler locates at the upper central part)

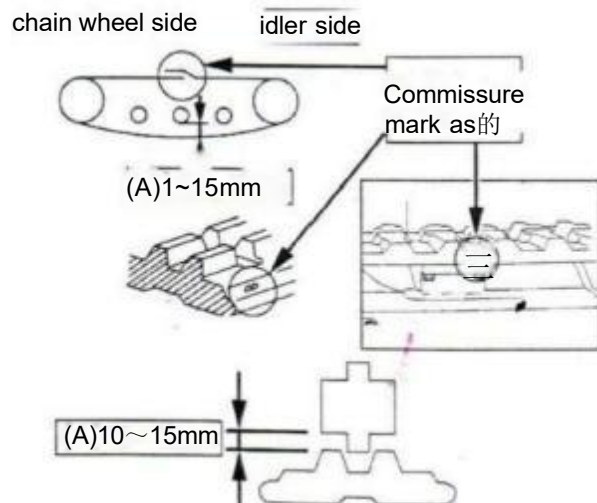
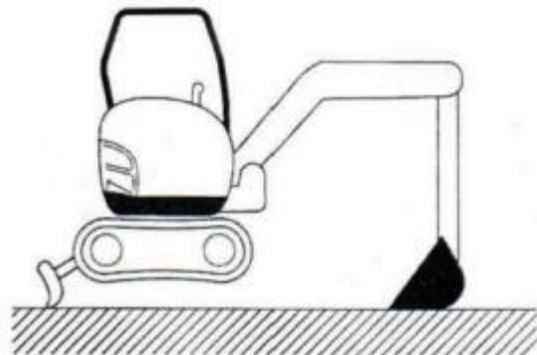

# Maintenance

- \* Revolve the crawler 1~2 circles to verify the tension degree of the crawler.

## Loosenina rubber crawler

Attention

- \* High pressure exist in the grease cylinder. The nozzle and grease would eject from the cylinder if the nozzle is too loose or unscrewed too fast. Keep your face off the nozzle in case of danger and unscrew the nozzle slowly.
- \* Remove detritus before work if the chain wheel is stuck by detritus.

1. Insert the sleeve spanner into the root of grease cylinder nozzle. Revolve it 3~4 circles to unscrew the nozzle.
2. If grease inflow out from the screw thread, revolve it with crawler hanging in air to unscrew the nozzle further. After adjustment
3. Tighten the hexagonal part of the nozzle with the sleeve spanner. Tightening torque is about 98~108Nm (10~11kgm).

### Important

- \* Adjust again if the droop of the crawler is 25mm.
- \* Verify the tension degree and adjust it again after the first 30 hours work. Verify it every 50 hours and adjust it if necessary afterwards.
- \* If the crawler is too tensioned, crawler wear would be accelerated.
- \* If the crawler is too loose, chain wheel would mesh badly and crawler wear would be accelerated.
- \* Sweep the crawler completely after work. Do not leave it alone when soil is stuck in the crawler.
- \* If soil is stuck in the crawler or the crawler is too tensioned, hang one side of the crawler in air with the boom, arm and bucket and revolve it to remove soil.

- ### Tensioning rubber crawler
1. Insert grease gun into the nozzle to inject grease.

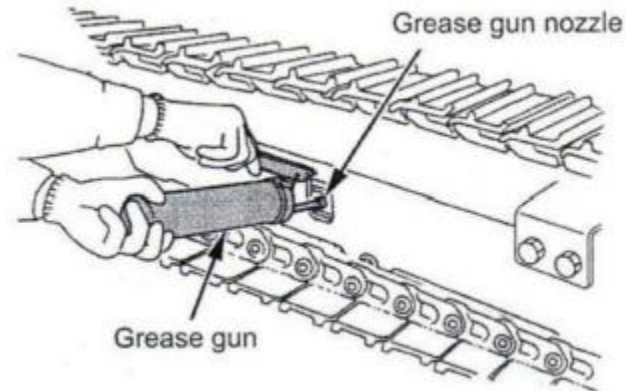

2. As shown in the figure, adjust size (A) (the gap between middle track roller outside and upper surface of the crawler) to the value shown in the figure at the state of crawler hanging in air, the tension state degree is the optimal at this time.

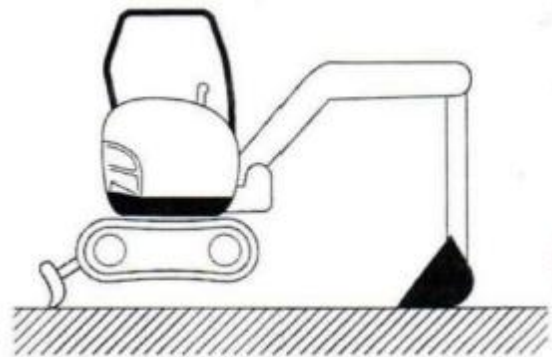

Drive wheel side                      Idler side

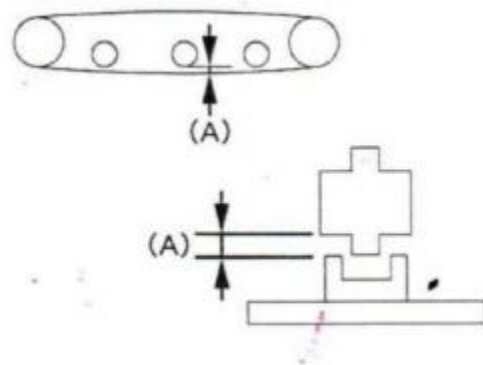

Gap (A)	25 ~ 30mm
---------	-----------

If you want to loose the crawler, follow the steps of rubber crawler.

- \* Look out the commissure on crawler. Make sure adjust the crawler when the commissure locates at upper middle position of the crawler. If the machine is equipped with upper revolving wheel, make it locates between the links. If not, the crawler can not be tensioned correctly.

#### How to use rubber crawler

1. Try to avoid swerving inplace. Instead, swerve circle round slowly to reduce crawler wear and being stuck by detritus.
2. Overflow valve works when the crawler is stuck by detritus. Do not swerve forcibly at this time. Instead, retreat straight and swerve after detritus is removed.
3. Do not drive on benchland, detritus ground, rebar and scrap iron. Otherwise, the rubber part of the crawler would be damaged and the life of the crawler would be shortened.

#### Change the bucket



Attention

- \*Wear safety helmet and goggles when replace the bucket.
- \* Use promissory gesture signals and communicate sufficiently to ensure safe when work in team.

Follow the steps below to replace the bucket.

#### **Important**

- \* Keep the pin off of soil and dinas.
- \* Dust seals is installed in the two sides of the sleeve .Do not damage the seals when assemble and disassemble the pin.

#### Disassemble the bucket

- 1 .Put the bucket down to ground.
2. Shut off the engine to release the pressure in hydraulic system.
- 3.Pull out pin A and B,and take out O-shape ring from the groove.

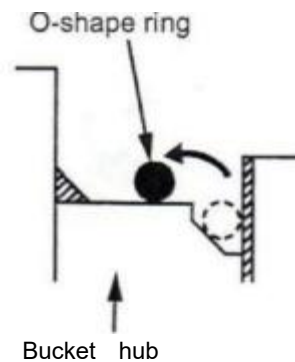

# Maintenance

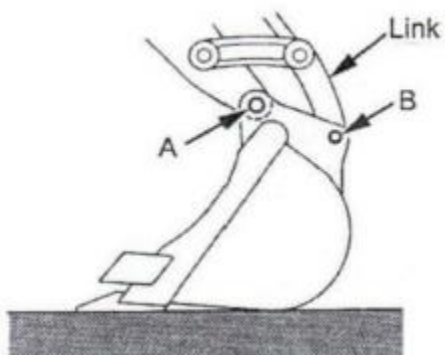

### Assemble the bucket

1. Put the O-shape ring to the bucket flange.
2. Align the arm to hole A, and put the shim into the gap of the arm, then connect with a pin. Align the link to hole B and connect with a pin.
3. Make sure install location bolt to the pin.
4. Install the O-shape ring to the groove.

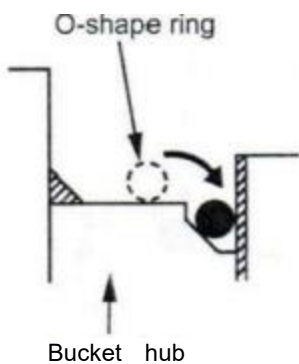

5. Inject grease to the pin.

### Change the bucket teeth and side teeth

#### Change the bucket teeth



### Warning

\* Make sure wear safety goggles during work.

1. Knock out the lock pin with punch and hammer.
2. Strike the worn bucket tooth with hammer. Pull out the bucket tooth from the connector.
3. Remove the soil attached to the connector.

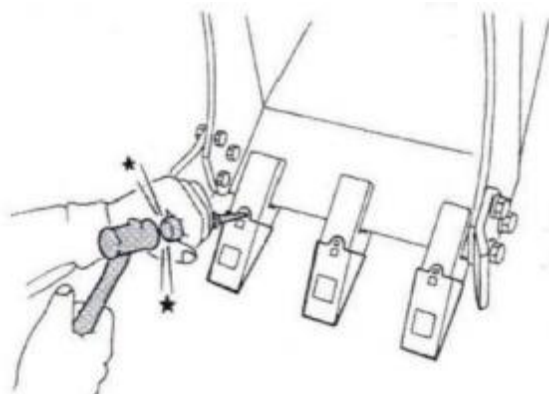

4. Put the rubber plug into the connector.
5. Align the new bucket tooth to connector and insert it into the connector.

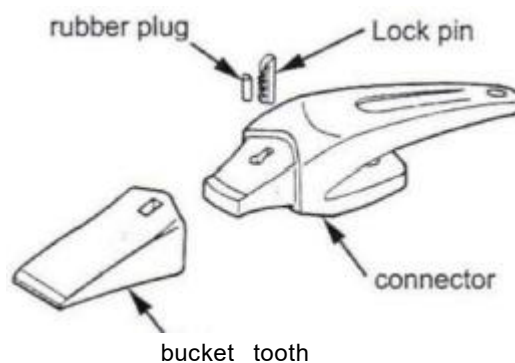

6.Strike the lock pin with bucket teeth hole aligning to the connector hole. Strike the pin firmly until the pin upper surface is in accord with the connector upper surface.

Replace the rubber plug and lock pin at the same time of installing the new bucket teeth.

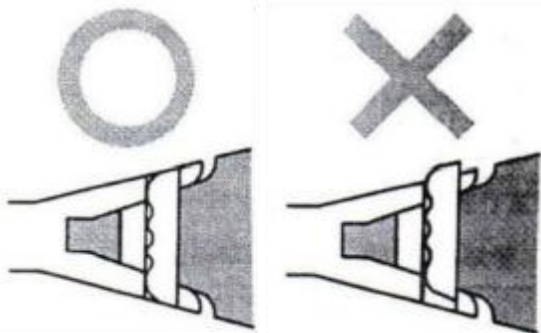

Change the side teeth

1. Disassemble the mounting bolt with the spanner.
2. Install a new lateral tooth. Tighten the bolt temporarily.
3. Tighten the bolt firmly after verify the lateral tooth contact with the connector of the bucket.

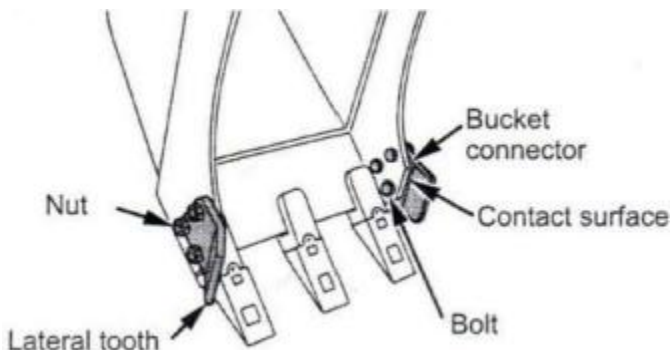

Tighten the with the torque of 215~245NM (22.0~25.01kgfm).

The bolt may be loose when the lateral tooth do not contact with the connector of the bucket or the tighten torque insufficient.

## Maintenance after long-term preservation

### Preservation if long time no used

1.Preserve the machine in a dry room after wash and sweep all parts of the machine. Do not preserve it outdoor.

If it is unavoidable to preserve outdoor, please park the machine on wood in a flat place and cover it with cloth.

2. Do not forget to add oil, inject grease and change oil.

3.Daub antirust oil sufficiently on the exposed surface of the piston rod.Daub antirust oil and start the engine monthly in order to ensure the lubricating oil flowing to everywhere of the hydraulic device. Daub antirust oil on the exposed surface of the oil cylinder rod.

4. Dismantle ground wire of the battery or disassemble the battery from the machine to preserve the battery.

5.When the air temperature decreases to below 0 ℃, add antifreeze fluid into the coolant or exhaust water completely.

### Rework after long-term preservation

1.Wipe off the grease daubed on oil cylinder rod.

2.Start the engine. Operate the working device and driving device with no-load to ensure the lubricating oil flowing to everywhere of the hydraulic device.

(When storage period exceeds 1 month, please carry out step 1 and 2 monthly.)

# Maintenance

---

## Use in cold season

---

### Safeguard procedures at low temperature

#### 1. Engine oil, hydraulic oil

Change the oil of specified viscosity

#### 2. Fuel

Use proper diesel oil according to air temperature.

#### 3. Battery

Electromotance reduces in low temperature. Battery diluent freezes when the charging capacity decreases. Therefore, make sure the charging rate exceeds 75% after shut off the engine. Be cautious of thermal insulation in order to start the engine the next day. If the liquid level is low, do not add distilled water after work, instead, add it before work in the next morning to avoid battery diluent freezing.

#### 4. Coolant

Please add antifreeze fluid.

Add antifreeze fluid into the coolant in the radiator and auxiliary water tank when the air temperature is less than 0 °C.

- Mixing ratio of water and antifreeze fluid

Minimum temperature (°C)	-5	-10	-15	-20	-25	-30	-35	-40
Antifreeze fluid volume (%)	30	30	30	35	40	45	50	55
Water volume (%)	70	70	70	65	60	55	50	45

---

## Supplement

- \* Please use long-acting or perpetual antifreeze fluid.
- \* Add the mixture of water and antifreeze fluid after coolant exhausts completely and incrustation is removed.
- \* Do not add detergent when use the antifreeze fluid because the antifreeze fluid has been added the antirust.
- \* Coolant  
Refer to Chapter "Change coolant".

### Cautions after work

Remove soil and water attached to the machine. Put the crawler on cement floor or dry place. The machine can not move if muddy water attached to the bottom of the driving device freezes. If appropriate parking lot is unavailable, please pave base plate or park the machine on grass mat. If park the machine on muddy ground, it can not move due to freeze and terminal drive gearbox may be damaged at this time.

Wipe the water attached to piston rod completely. If not, seals would be damaged by freezing water and soil.

## Regular replacement of important parts

To ensure safety, regular maintenance is required. In order to enhance safety, important parts especially the following parts related to safety and fire should be replaced regularly by the authorized dealer and assigned repair factory.

These parts are liable to wear and age with time. The service conditions of these parts are difficult to estimate in regular maintenance. Therefore, to ensure normal working, even if no abnormality appears, replace these parts also after serve a period.

If abnormality appears before expiration date, repair or replace the invalid parts according to conventional methods.

Replace the hosepipe together with the clamps if the hosepipe inflates, hardens or crazes.

Check the hydraulic hose as shown below. Reinforce and replace the hydraulic hose if abnormality appears.

Replace the hydraulic hose together with O-shape ring and the seals.

Authorize the dealer or assigned repair factory to replace the important parts.

- Regular check the following items and check fuel hosepipe and hydraulic hosepipe at the same time.

Category	Item
Regular check	Leakage of connectors and rivet connections of fuel and hydraulic hosepipes
Routine check monthly	Leakage of connectors and rivet connections of fuel and hydraulic hosepipes Damage(chap, wear, tease) of fuel and hydraulic hosepipes
Specific check annually	Leakage of connectors and rivet connections of fuel and hydraulic hosepipes Disturbance, chap, aging, rupture, damage(chap, wear, tease) of fuel and hydraulic hosepipes

- Important parts list

No.	Parts required replace regularly	Quantity	Replace period
1	Fuel hosepipe(fuel container~fuel filter)	2	Every 2 years or 4000 hours, whichever comes first.
2	Fuel hosepipe(fuel filter~fuel pump)	2	
3	Fuel hosepipe(fuel pump~fuel nozzle)	2	
4	Fuel hosepipe(fuel nozzle~fuel container)	1	
5	Fuel hosepipe(fuel container~fuel emission)	1	
6	Fuel hosepipe(Main pump sucking oil)	1	
7	Fuel hosepipe(Main pump priming pump)	4	
8	Fuel hosepipe(boom oil cylinder)	2	
9	Fuel hosepipe(Arm oil cylinder)	2	
10	Fuel hosepipe(bucket oil cylinder)	2	
11	Fuel hosepipe(swing oil cylinder)	2	
12	Fuel hosepipe(dozer blade oil cylinder)	2	
13	Fuel hosepipe(Ancillary pressure supply port)	4	

## Questions and solutions of backhoe excavator

If any malfunctions appear with the small size backhoe excavator, please diagnose it and take measures according to the table below.

If any questions appear, please refer to the dealer or assigned repair factory.

	Condition	Reason	Solution
Engine	The engine is difficult to start	(1)The fuel can not flow.	1) Check the fuel container. Remove precipitated impurities and water. (2) Check fuel filter. Replace it if dirty.
		(2)Air or water is mixed into the fuel supply system.	(1) Check pipe and clamps. Replace or repair if damaged. (2)Exhaust air.(Refer to Chapter" Exhausting of fuel system)
		(3)Engine oil viscosity increases in cold weather, which cause engine revolves heavy.	(1)Add hot water into radiator. (2)Use engine oil according to air temperature(Use SAE10W30 in winter)
		(4)Battery energy is nearly used up and enough start force can not be supplied	(1)Charge the battery.
	Output power is insufficient	(1)Fuel is insufficient.	(1)Add fuel.
		(1)Air filter is clogged.	(1)Clean the filter.
	Shut off suddenly	(1)Fuel is insufficient.	(1)Add fuel.
	Tail gas color is abnormal black	(1)Fuel is poor quality. (2)Engine oil is over much.	(1)Change to high quality fuel. (2)Adjust the oil volume to normal level.
	Radiator alarm blows	(1)Water pump seal is poor. (2) Fan belt is elongated or fractured (3) Thermostat is poor. (4) Coolant is insufficient. (5) Radiator nets or fins are dusty. (6) Coolant is polluted by rust of oil cylinder cover and crankcase. (7) Radiator cover seal is poor (evaporation). (8) Coolant channel is corroded. (9)Overload runs continuously. (10) Radiator gasket is damaged. (11) Engine oil is insufficient. (12) Fuel ejecting time is not suitable.	(1)Replace. (2)Adjust or replace. (3)Replace. (4)Add to specified level. (5)Clean. (6)Change coolant, add antirust. (7)Replace. (8)Swash. (9)Reduce load. (10)Replace. (11)Add to specified level. (12)Adjust. (13)Change to high quality fuel.
	Hydraulic equipment	Working device(boom, arm, bucket) rotate, drive, dozing force insufficient, low speed or unmoved.	(1)Hydraulic oil is insufficient. (2)Hosepipe,line connector leak oil.
No moving with rotating operation		(1)Locked by rotating frame locating pin.	(1)Pull up the Stop pin handle.
Driving equipment	Can not drive	(1)Crawler is stuck by detritus. (2)Crawler is too tight or too loose.	(1)Remove the detritus. (2) Adjust.

## **Cautions in using the hydraulic hammer**

---

### Assembling of hydraulic hammer

---

Please install suitable hammer. The service life of the machine not only would be affected, safety problem may also be caused if unsuitable hammer is installed.

# Cautions in using the hydraulic hammer

## Cautions in using the hydraulic hammer

### Prohibition 1 Working posture

If the front part of the machine is uplift more than 5cm in breaking work, the machine may stumble frontwards at the same time of the stone is broken. As a result damage of the hammer or bracket may be damaged by striking. In addition, vibration produced in breaking work may spread to the crawler. Therefore, do not take this way in breaking work.



### Prohibition 2 Do not move stone with the hammer.

Do not move or pull down stone with hydraulic force of the boom, arm, etc. Installing bolts may be broken, bracket may be damaged, hammer rod may be broken or stuck, boom or arm may be damaged by this working way.

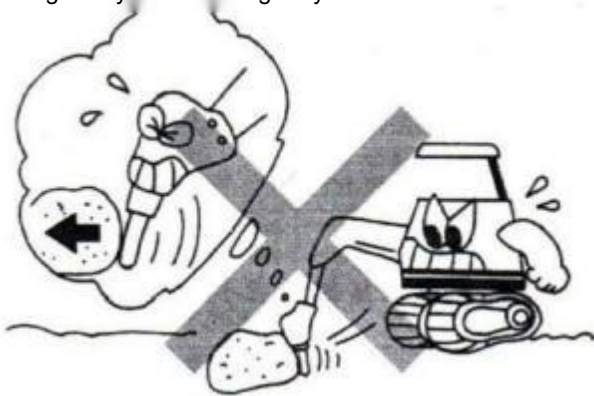

**Prohibition 3** Do not carry out breaking work by levering. Installing bolts and hammer rod may be damaged by this breaking way.

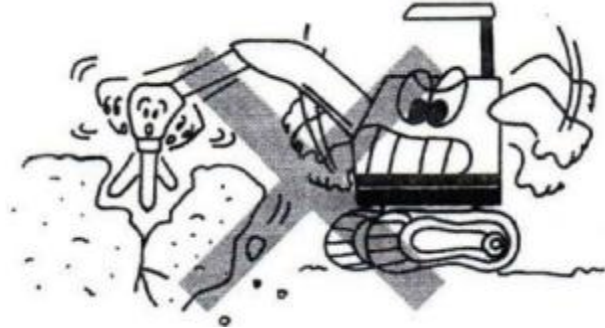

**Prohibition 4** Do not carry out breaking work in water or mud.

Do not put parts except the hammer rod into water or mud in breaking work. Piston rod may rust and malfunctions of the hammer may be caused by this working way.

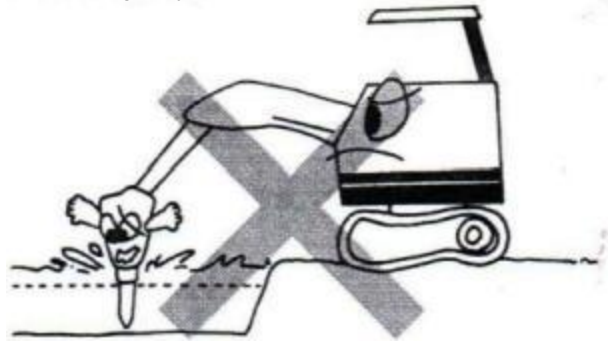

**Prohibition 5** Do not break stone by the hammer falling down.

The hammer or other parts would be damaged if excessive force is applied to the hammer or the machine.

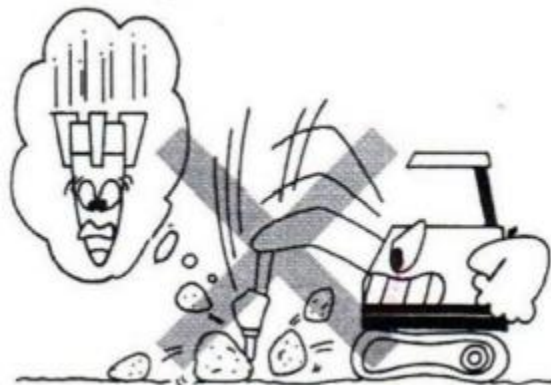

## Cautions in using the hydraulic hammer

**Prohibition 6** Do not carry out breaking work when the hydraulic stroke is at the terminal point. Parts in the oil cylinder may be damaged when breaking work with the hydraulic stroke at the terminal point (the maximal lengthening or the maximal shortening state of the oil cylinder).



**Prohibition 9** Do not carry out horizontal or upward breaking work.



**Prohibition 7** Do not carry out lifting work. Do not carry out lifting work with the hydraulic hammer.

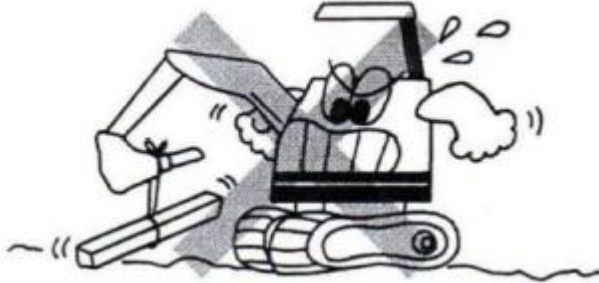

**Prohibition 10** Do not carry out aerial breaking work in case of stone falling or vehicle turnover.

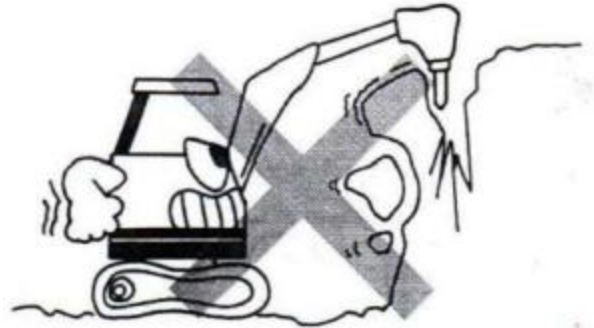

**Prohibition 8** Do not carry out breaking work toward the two sides. Vehicle turnover may be caused and service life of wheels may be shortened by this working way.

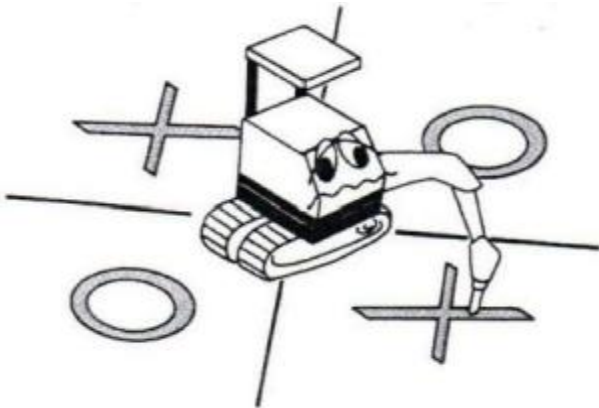

## Cautions in using the hydraulic hammer

---

### Attention 1

Put the hammer perpendicular to the impact surface when carry out breaking work. In addition, apply pushing force consistently during breaking work. Do not strike without hitting the object.

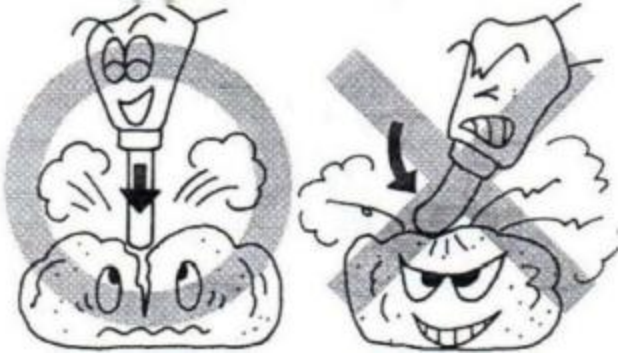

### Attention 4

Work after verify the ground is solid.

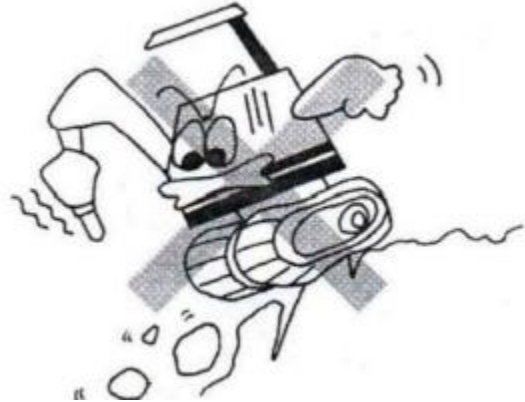

### Attention 2

When the same impact surface is stroked continuously without it being broken or drilling in, please change the impact surface and carve it from the top.

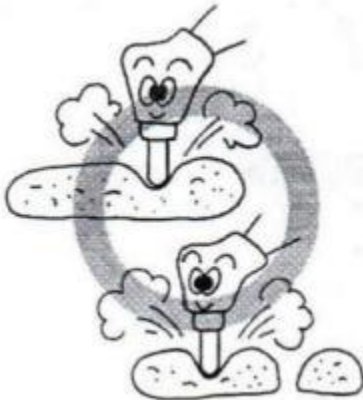

### Attention 3

Do not hit the boom or boom oil cylinder when draw back the hammer.

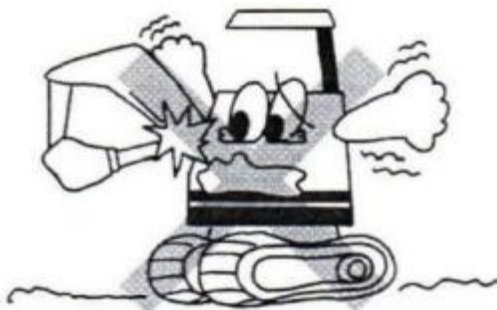

## The recommend lubricating grease

- Make sure use the authentic Our Company oil and lubricating grease as shown in the following table.

Manufacturer	hydraulic oil	Engine oil	Universal grease
SHELL	hydraulic oil S46 (Hydraulic S46)	SAE 10W30 Level CF	
Cartel			Universal 2#Li

The recommend lubricating grease

Manufacturer	Engine oil	hydraulic oil	gear oil
Mobil	Delvac MX(15W-40) Delvac Surper Multigrades(10W-30/15W-40)	DTE 25(VG46)	Mobilube HD 80W-90
ESSO	Superflo(10W-40)	NUTO H46	Gear oil GX 80W-90
SHELL	RIMULA(SAE10W-30)	Tellus ST46	SPIRAX EP90
CALTEX	(RX Super) SAE15W-40; (RX Super Plus) SAE10W-30	HYDRAULIC series (VG46)	
TEXACO	Havoline® Motor Oil 10W-30		Havoline® Gear Oil 80W-90
JOMO	JOMO DIESEL CF-4(SAE15W- 40)/ JOMO DIESEL CD(SAE10W-30)	JOMO Hydlux (VG46)	JOMO GEAR 5

※ When change the oil, please drain all original oil and then add new oil.

※ Please use the fuels below:

- (O# diesel oil: in summer

- -10#,-20#,-35#:in winter or according to the local air temperature

# Appendix

## Dimensional drawing

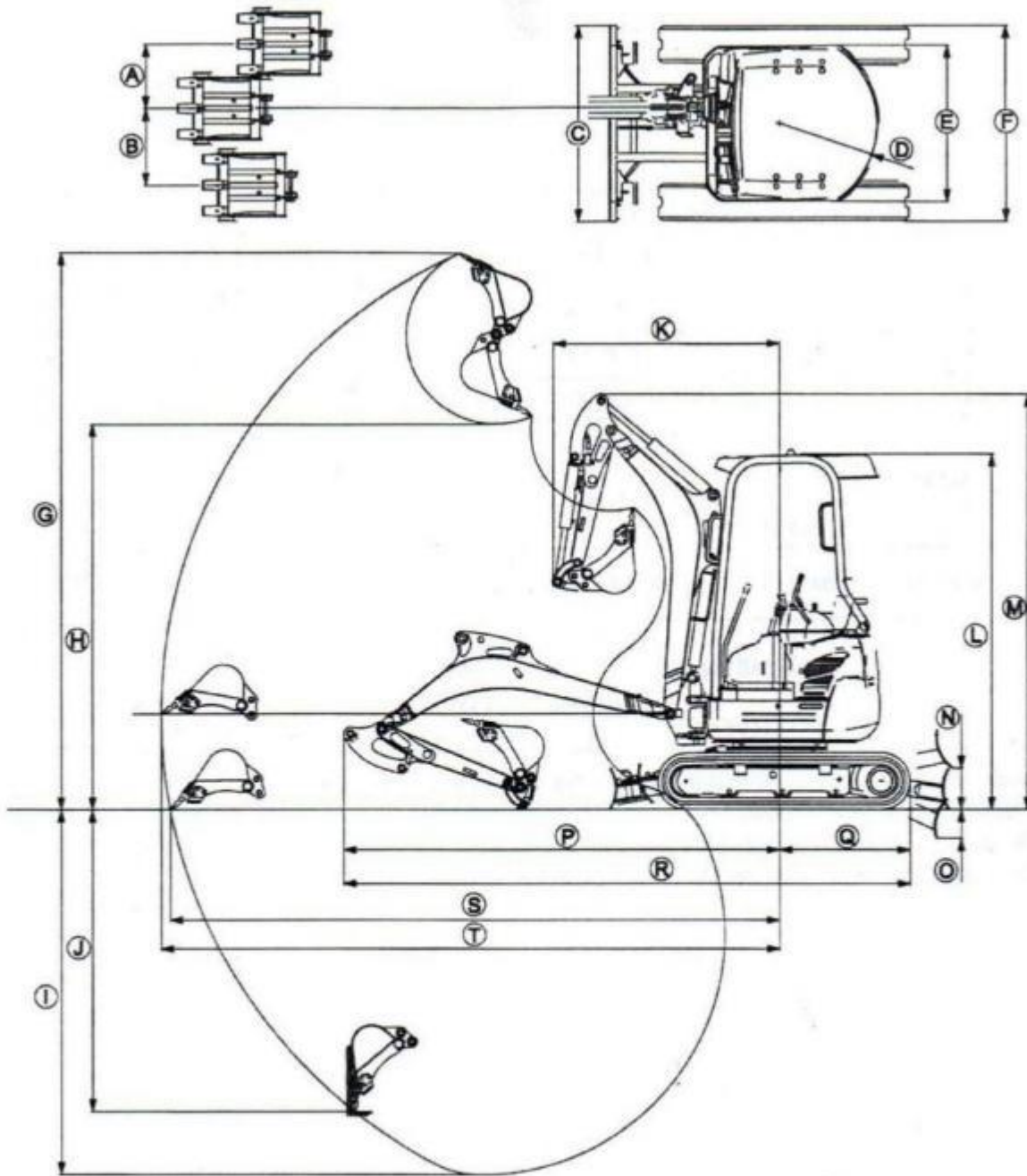

unit: mm

(A)	(B)	(C)	(D)	(E)	(F)	(G)	(H)	(I)	(J)	(K)	(L)	(M)	(N)	(O)	(P)	(Q)	(R)	(S)	(T)
410	485	990/ 124 0	620	980	990/ 124 0	3540	2440	2310	1910	1430	2250	2630	245	200	2750-	815	3570	3840	3900