



With over thirty years of continued development, Mocal Oil Thermostats have racked-up millions of miles in automotive, marine and aviation applications. Select from in-line or sandwich plate type (next pages), in any of the available options.

Oil Thermostat Push-on OT1 Type

Part #	Description	Price
A0T1	1/2" Push-on Barb	\$90.00
A0T1-HT	1/2" Push-on High Temp*	\$95.00
A0T3	3/8" Push-on Barb	\$90.00
A0T3-HT	3/8" Push-on High Temp*	\$95.00

**High temperature (95c / 203f) versions are best suited for regulating flow to automatic transmission coolers in colder than average climates.*

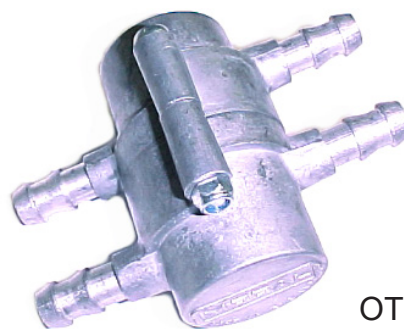

OT1

Oil Thermostat Male Thread OT2 Type

Part #	Description	Price
A0T2-B1/2	1/2" BSP Male	\$190.00
A0T2-B5/8	5/8" BSP Male	\$190.00
A0T2-8	-8AN Male	\$190.00
A0T2-8HT	-8AN Male High Temp*	\$200.00
A0T2-10	-10AN Male	\$190.00
A0T2-10HT	-10AN Male High Temp*	\$200.00
A0T2-12	-12AN Male	\$190.00
A0T2-12HT	-12AN Male High Temp*	\$200.00
A0T2-16	-16AN Male	\$190.00
A0T2-16HT	-16AN Male High Temp*	\$200.00

**High temperature (95c / 203f) versions are best suited to marine and aviation applications.*

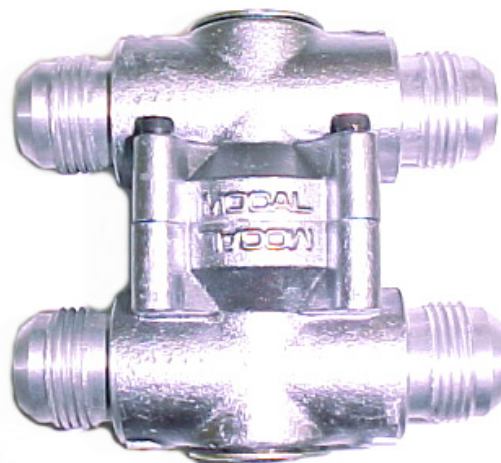

OT2

Oil Thermostat Female Thread OT2 Type

Part #	Description	Price
A0T2-B1/2F	1/2" BSP Female	\$190.00
A0T2-N1/2F	1/2" NPT Female	\$190.00
A0T2-M22F	22mm Female	\$190.00

For other fluid connection options these female threaded versions of the OT2 use either 1/2 BSP, 1/2 NPT or 22mm male unions.



OT2

SP16T
Chevy V8



TOP1LPT
VW VR6 w/thermo



SP1
non-thermo



SP1TM18
low clearance w/thermo
includes swivel -10AN
banjo male fittings



SP1T
with thermo



MOCAL manufactures the industries widest range of **Sandwich Plate Adaptors**. These devices are designed to be installed between the engine block and oil filter and easily allow engine oil to be circulated for remote oil cooler installations. We can supply sandwich adaptors in all popular oil filter thread configurations (3/4", 5/8", 13/16") SAE and (18mm, 20mm, 22mm) metric sizes for fitment to virtually all engine applications. Mocal Sandwich adaptors are optionally available with built in thermostat (180 degree) which accurately controls oil flow to the cooling device allowing for quick engine warm up plus oil system protection in cold climates. We have even designed special sandwich plate adaptors for unique engine applications like Chevrolet V8, Volkswagen VR6, and tight clearance installations (w/ rotating -10AN banjo oil in/out). Units are made from cast aluminum and are supplied with sealing o-rings and extension screw to match desired filter thread. Oil inlet/outlet ports are 1/2" female thread to designed to receive male/male unions which are available separately.

USA

MOCAL

MOCAL

USA

Thermostatic Models

Part	Filter Thread Size	Price
SP1T	3/4"-16	\$115.50
SP1AT	5/8"-18	\$115.50
SP1CT*	13/16"	\$115.50
SP1DT	18mm	\$115.50
SP1FT	20mm	\$115.50
SP1GT	22mm	\$150.00
TOP1LPT	VW VR6	\$165.00
SP1TM18	Optional	\$190.50



Note: Threaded adaptors are available in -AN, BSP & metric sizes for all components we offer.

*NOTE: Chevy SB & BB use SP16T

BOTTOM VIEW

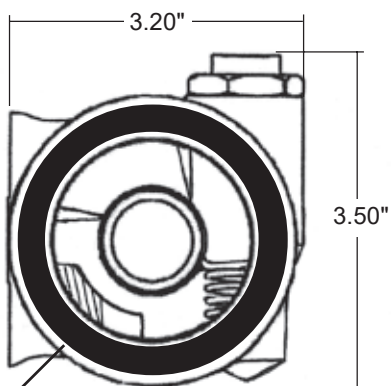

SIDE VIEW

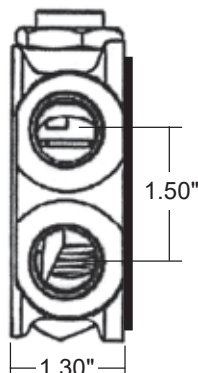

TOP VIEW

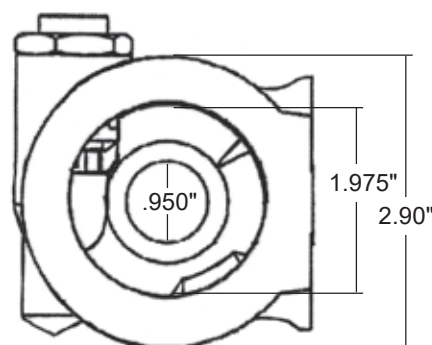

O-RING (min 2.20", max 2.85")

Mocal Sandwich Plate Kit with fluid connections

Now our most popular oil cooler sandwich plates are now available with union/adapters for -AN fluid connections. We have added part numbers that include the union/adapter fittings for hose connection in either -8AN or -10AN as a kit, making it easier to purchase as everything is now included. Choose from either a 3/4"-16 or M20 x 1.5 version which covers 90% of vehicle applications. All are best quality component on the market from **MOCAL**, the originators of the thermostatic sandwich plate (35+ years and over a million units in service).

MOCAL sandwich plates install between the engine block and oil filter easily allowing engine oil to be circulated for oil cooler installations. **MOCAL** sandwich plates include a built-in thermostat (180° degree) which accurately controls oil flow to the cooling device allowing for quick engine warm up plus oil system protection in cold climates. Like original equipment quality automotive aluminum parts, **MOCAL** sandwich plates are pressure die cast using A360 aluminum (not cheap pot/white metal). Units are supplied with M22 x -AN male fittings (-8AN or -10AN) sealing o-rings and extension screw (3/4"-16 or M20 -1.5) to match engine oil filter thread. Weight 0.82Lb. with fittings. Made in England.



MOCAL
oil control systems



MOCAL
oil control systems



MOCAL
oil control systems



**Thermostatic Sandwich Plate for 3/4"-16 filter
-8AN union/adapters supplied. SP1T-8 \$125.50**

**Thermostatic Sandwich Plate for 3/4"-16 filter
-10AN union/adapters supplied. SP1T-10 \$125.50**

**Thermostatic Sandwich Plate for M20 x 1.5 filter
-8AN union/adapters supplied. SP1FT-8 \$125.50**

**Thermostatic Sandwich Plate for M20 x 1.5 filter
-10AN union/adapters supplied. SP1FT-10 \$125.50**

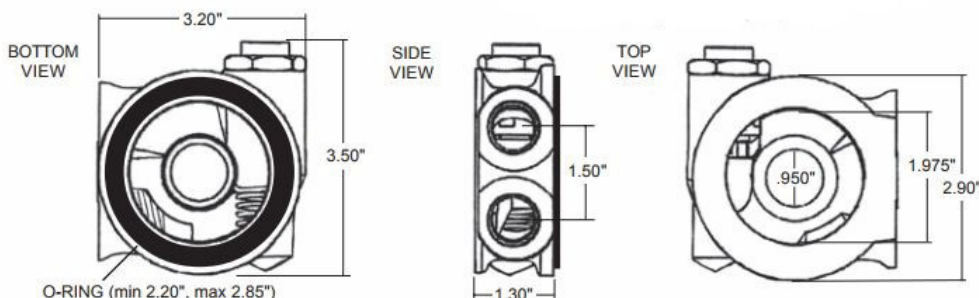

SP1THF Hi-Flow Thermostatic Sandwich Plate

Hi-Flow Thermostatic Sandwich Plate

The new addition to the **MOCAL** Sandwich plate line is this "Hi-Flow" model. This unit is a recent development for a well known marine engine supplier, and designed to their specification. If any of the features or dimensions make it more desirable than the standard SP1T type plate, it can be used it as an alternative. The most notable feature of this new sandwich plate is its ability to use -16AN plumbing- thus the "High-Flow" designation. Overall it is physically 10% larger than our standard SP1T (internally and externally), uses a redesigned thermo-shuttle assembly, tapped for 22mm (inlet/outlet) ports, and is compatible with larger oil filters. For the price we supply SP1T-HF with your choice of extension screw (3/4", 13/16", 18mm or 20mm) and M22 x (-8AN, -10AN, -12AN or -16AN) unions.

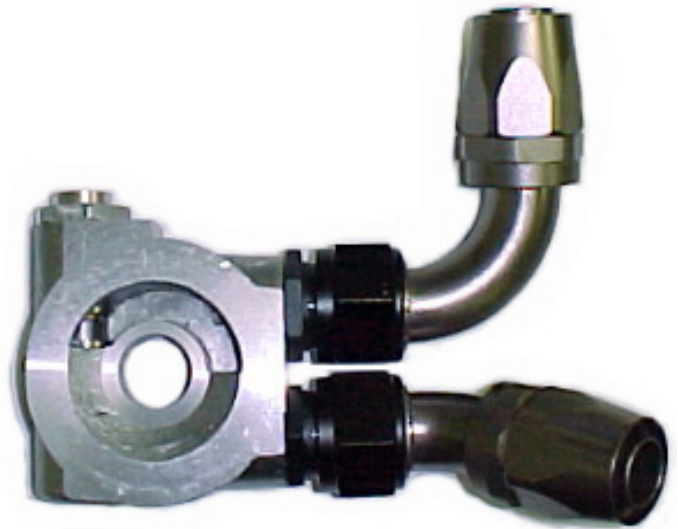

SP1T-HF shown with -16AN Fittings

Hi-Flow Sandwich Plate SP1T-HF \$165.00
 price includes (1) sandwich plate, (1) extension screw,
 (2) male/male unions

Extension
Screw

3/4-16"
13/16"
18mm
20mm



Male x Male
Unions

M22 x -8AN
M22 x -10AN
M22 x -12AN
M22 x -16AN

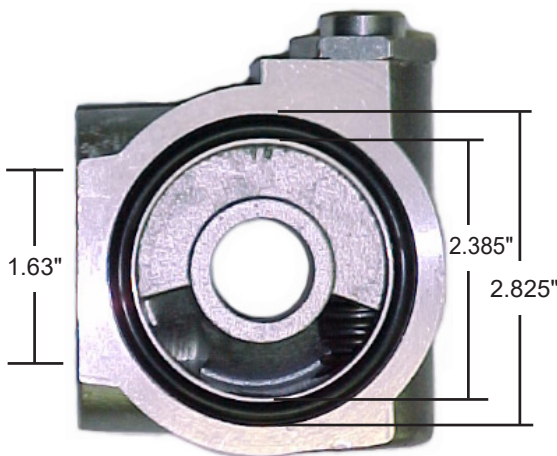

Port center to center & O-ring dimensions



1.265"

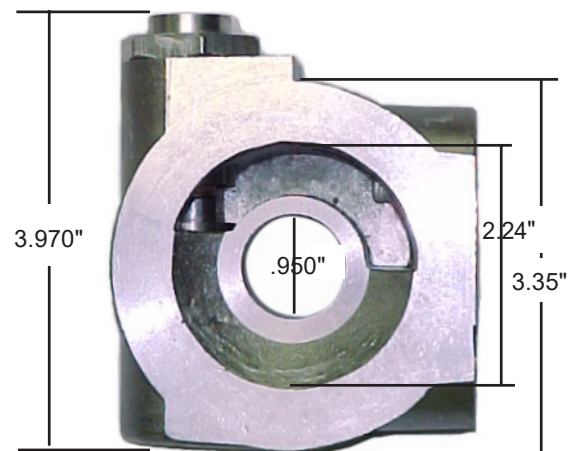

max. width, O-ring pad & center bore dimensions

BRZ/FR-S/GT86 Thermostatic Sandwich Plate

Mocal is first to the market with our thermostatic oil cooler sandwich plate kit for new 2.0L Subaru (FA20) powered BRZ/FR-S/GT86 type cars. We have been working with tuners and race teams regarding the need for proper oil cooling on these engines and due to their high revving nature oil temps can reach levels that cause the engine management to reduce performance. Get the most from your standard or modified engine by adding a highly efficient Mocal or Setrab oil cooler and control oil flow with a genuine Mocal thermostatic sandwich plate. Built in thermostat (185 degree) accurately controls oil flow to the cooler allowing for quick engine warm up plus oil system protection in cold climates. Kit for 2.0L (FA20) engine

includes: sandwich plate w/built in thermostat, interlocking 25mm spacer required for proper height/clearance, lengthened 20mm x 1.5 filter extension, large section o-rings. Fluid connections are ORB 1/2" BSP available to either -8AN or -10AN sold separately below.



description	part#	price
Sandwich Plate <i>FA20 engine 20mm oil filter thread</i>	SP1T-FA20	\$180.50
Union M22 X -8AN (each)	M22AN08SE	\$7.90
Union M22 x -10AN (each)	M22AN10-SE	\$7.90
Sandwich Plate Kit <i>Includes (2) M22 x -8 Unions</i>	SP1T-FA20-A8	\$190.50
Sandwich Plate Kit <i>Includes (2) M22 x -10 Unions</i>	SP1T-FA20-A10	\$190.50

NOTE: For use with water to oil coolers, a non thermostatic version of this part is also available as part # SP1-FA20 (\$129.00)



BRZ/FR-S/GT86 Plate w/Banjo Fittings

description	part#	price
Sandwich Plate Kit <i>with -10AN Banjos</i>	SP1T-FA20-B10	\$235.00

Some installations, especially ones with turbo kits on Subaru BRZ/FRS (FA20 engine) might require alternative sandwich options for additional clearance. We have developed this option with banjos fittings that can rotate independently for added versatility.





Note: Threaded adaptors are available in -AN, BSP & metric sizes for all components we offer.

MOCAL USA

MOCAL USA

SP2TC Billet Thermostatic Sandwich Plate

Diesel Thermostatic Sandwich Plate

Our standard range of sandwich plates serve most engines with spin-on oil filters generally less than 3". This does not account for many diesel or industrial engine applications where the filter o-rings are in the 3.25" - 3.75" range. With this in mind we have developed a new large format version of our popular engine oil cooler sandwich plate. Our new SP2CT sandwich plate attaches simply to the engine between the oil filter mount and standard filter. It offers a integral 190° bypass type oil thermostat which allows for quick warm up even with large oil coolers in cold climates. The plate is tapped for M22 thread inlet/outlet ports which can support even the most generously sized -16AN hose fittings. Construction is billet aluminum which is strong which still being lightweight. All ports, fittings and flanges are o-ring sealed. There is also a 1/8" NPT port provided (w/plug) for adding a gauge, sensor or additional oil tap. The filter thread is 13/16"-16 which suits GMC Duramax diesel engines. We will be adding other filter options for future applications.



Billet Thermo Sandwich Plate

SP2CT

\$149.00

for 13/16"-16 oil filters

Fittings for Above (2) required:

Union M22 x -10AN

M22AN10-SE

\$7.90

Union M22 x -12AN

M22AN12-SE

\$7.90

Union M22 x -16AN

M22AN16-SE

\$9.60



Note: Threaded adaptors are available in -AN, BSP & metric sizes for all components we offer.

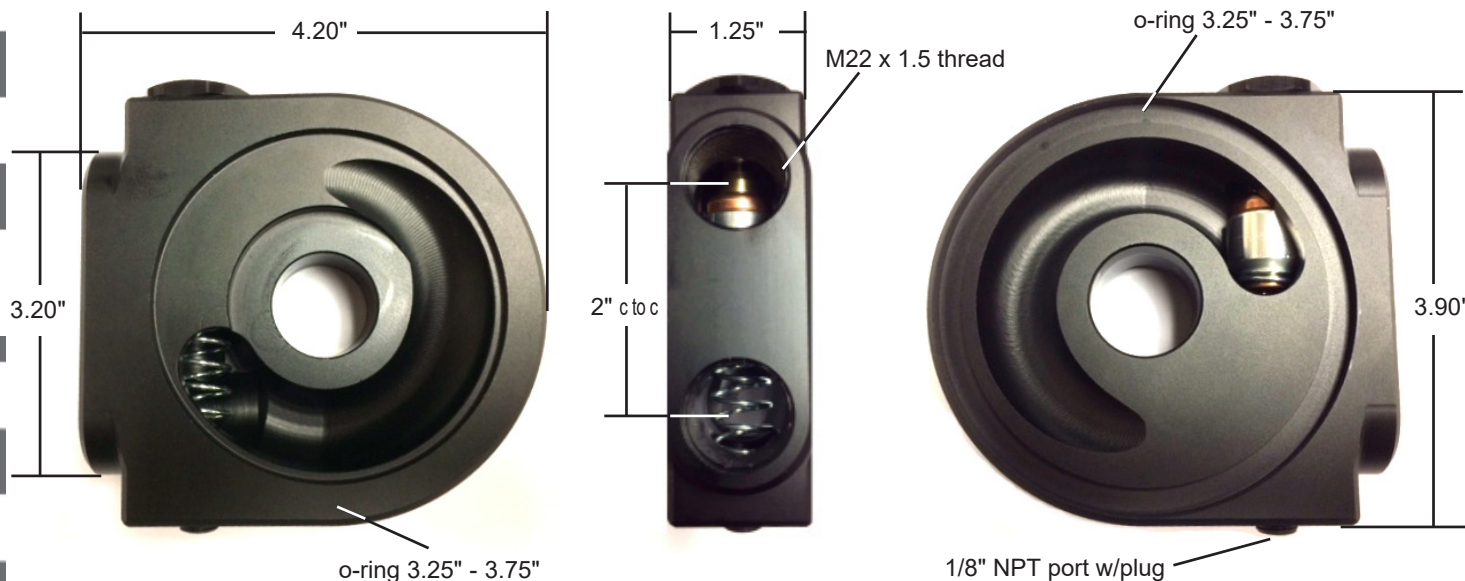



Thermo Sandwich Plate Small & Big Block Chevy

Introducing the ultimate thermostatic sandwich plate for small and big block Chevrolet V8's. Mocal's billet aluminum SP16T is a single piece unit with a built-in spacer for a reliable and robust seal against the unique recessed oil filter surface of the SBC and BBC engines. The sandwich plate is installed between the engine block and the oil filter allowing the user to plumb an oil cooler to any SBC or BBC engine and features a built-in 190°F (88°C) thermostat which bypasses the oil cooler until the oil has reached its minimum operating temperature. When used in conjunction with an oil cooler, this results in quicker engine warm-ups and prevents oil viscosity loss in colder conditions. Sandwich plate rotates 360 degrees around the inner extension screw for optimal positioning of adapter fittings



1/8" NPT gauge port w/plug

Specifications:

Built-in 190°F (88°C) thermostat; Uses factory equivalent oil filter Machined from billet aluminum and hard anodized (Black). O-Ring (ORB) fluid connections; (2) female M22x1.5mm ports that adapt easily to -AN -8, -10, or -12; Additional 1/8" NPT gauge/ auxiliary port with plug; Designed and made in England; Weight: 1.75 lbs / dimensions below.

Billet Thermo Sandwich Plate
for 13/16"-16 oil filters

SP16T

\$189.50

Fittings for Above (2) required:

Union M22 x -8AN

M22AN8-SE

\$7.90

Union M22 x -10AN

M22AN10-SE

\$7.90

Union M22 x -12AN

M22AN12-SE

\$7.90

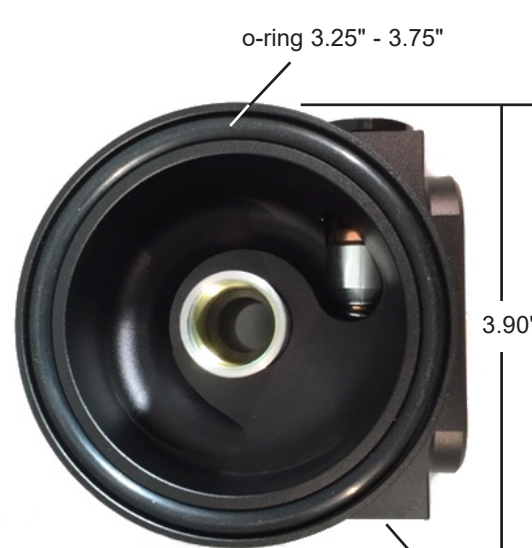
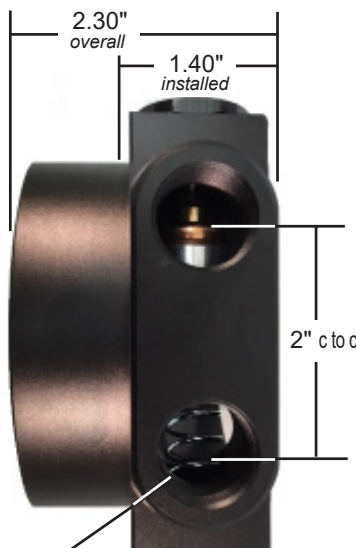
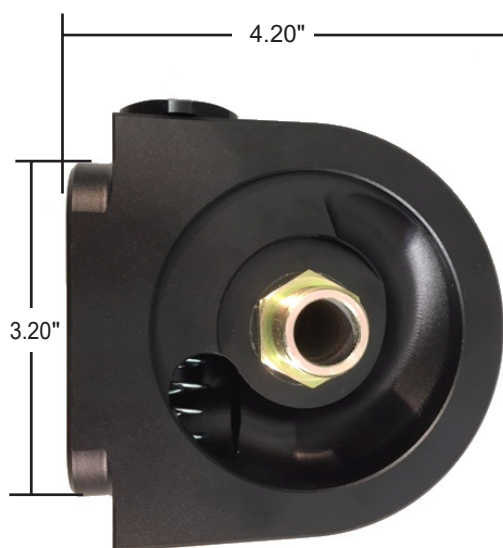

M22 x 1.5 thread ports (2)

1/8" NPT port w/plug

Thermostatic Take-off Plates for GM LS engines

GM LS Engine Oil Take-off Plate w/Thermo

application	port thread	part#	price
Chevy LS Engines	M22 x 1.5	AOTGM	\$190.00

The Mocal thermostat incorporates a thermostatic control that automatically regulates oil flow to connected cooling devices and is the answer when installing oil cooling on high performance engines that see street/track use in varying climates and conditions. The thermo simply bolts in place of factory gauge sender and operates by bypassing oil until minimum temperature (200f) are met before sending full oil flow to the cooler(s). Units are threaded for M22 x 1.5 female oring boss fluid connections (included to -10AN) with provision for factory M12 x 1.5 sender; includes required hardware and oring/gaskets.

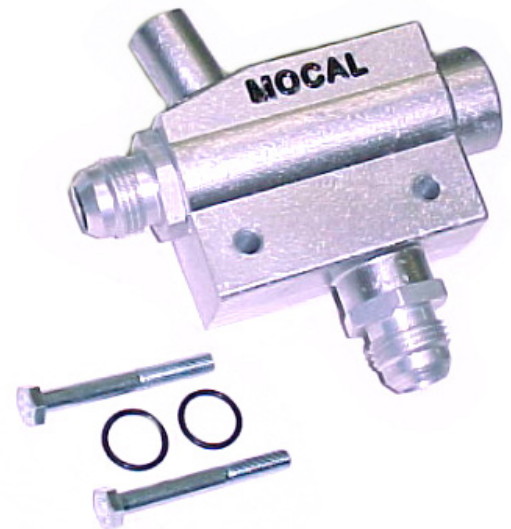

Note: Threaded adaptors are available in -AN, BSP & metric sizes for all components we offer.

GM LS Engine Oil Take-off Plate w/Thermo

application	port thread	part#	price
Chevy LS Engines	M22 x 1.5	T0PLS-T	\$180.00

Bolt-on billet oil take off's plate with incorporated 180° thermostat replaces blank plate or gauge sender plate on LS type engines providing fluid connections for oil cooling. Threaded for M22 x 1.5 o-ring boss type connections with provision for (2) 1/8" NPT sender or oil feed. Includes hardware & gasket. Fittings for fluid connection are sold separately. Suitable for 97 and later rear sump LS and Vortec Gen 3 & 4 engines. Not for front sump or LSX. Some aftermarket headers can make for a tight fit with hose connections.



VW/AUDI RELATED

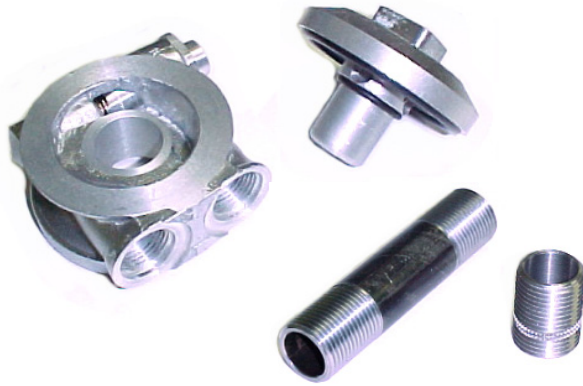

The TOP1LPT is supplied with both long & short threaded extensions allowing installation with, or without, factory VW heat exchanger.



A version with longer extension is available for engines using larger (thicker) 3" factory heat exchanger.

VW/Audi VR6 12v, 24v, R32 & Others

The TOP1LPT thermostatic oil take-off plate allows external oil cooling to be added to VR6 type engines. VW/Audi equips most of its engines with a small water to oil heat exchanger located between the engine block and oil filter. As the VR6 engine uses with a canister type oil filter, the factory water/oil heat exchanger is instead located on the front of the engine block retained by a cap that mounts the device to the engine. The Mocal TOP1LPT is designed to fit in this location and thermostatically control oil flow to a remote mounted oil cooler. The TOP1LPT can be installed with the factory heat exchanger in place or deleted; we provide both a long and short length threaded extension for installation.

description	part#	price
VR6 Oil Cooler Take-off w/ thermo	TOP1LPT	\$165.00
VR6-32* Oil Cooler Take-off w/ thermo	TOP1LPT-32	\$175.00

**Version with longer extension is available for engines using larger (thicker) 3" factory heat exchanger.*

VW/Audi TSi/FSi

VW/Audi TSi / FSi type engines date from 2006-2014 and come installed in a wide range of VW and Audi vehicles. Unfortunately it gets confusing as there are numerous engine and vehicle codes for this series applications. The correct engine will have the oil filter at the top front corner of the engine, facing up near the alternator and water/oil cooler. The mount for the filter will be aluminum not plastic. The engine will have chain driven camshafts not belt. The stock oil filter on these engines is unique as it uses a male M27 threaded lance to engage a drain back feature. Our sandwich plate is compatible and once installed will permit the use of a more common oil filter in 3/4"-16 like is used on 1.8T type engines.



description	part#	price
VW/Audi Thermo Sandwich Plate TSi	SP1T-FSi	\$150.00

AOT2 Oil Thermostat Instructions

Function

Mocal oil thermostats are designed to regulate oil flow through cooling devices until optimal (minimum) temperatures are reached. Cold oil enters the thermostat and is bypassed through the center of the unit returning to engine (figure 1). During warm-up the thermostat never closes off oil flow to the cooler, rather, it offers a less restrictive path for the oil to flow* allowing the cooler to acclimate to system temperature. As oil warms to 180 degrees (200 in high temp versions) the operating "waxstat" closes the bypass permitting full flow to cooler (figure 2). *percentage of oil bypass can vary up to the point where the bypass is closed and full flow to the cooler is achieved.

Thermostat Installation

1. Select a place, close to the engine and away moving parts, to insert the thermostat where oil hoses are running parallel. If a remote filter is used the thermostat must be installed AFTER the filter or oil bypass unfiltered when cold.
2. Determine the orientation of the thermostat prior to connecting the hose fittings see (figure 3). Yes, it is normal to see straight through both ends of the thermostat; the bypass function of occurs in the (unseen) center portion.
3. Splice the thermostat in the hoses running to and from the cooler using 4 appropriate type hose ends. Follow schematic (figure 4 or 5). Notes: Thermostat can be installed in any position/orientation as long as above connection schematic is followed. Unless marked, oil coolers do not have a preference for inlet or outlet, oil will flow in either direction. If marked, connect "to cooler" port to cooler inlet and "from cooler" port to cooler outlet.

Other questions or issues should be directed to our technical department at (941) 355-0005.

