

# MARINE.

High speed engines for pleasure boats.



MAN Engines



# PURE PLEASURE.

Performance gives power its beauty: With powers ranging from 730 to 2,200 hp. MAN engines impress with their extraordinary dynamics, their extreme running smoothness, economy and their trend-setting environmental friendliness. The finest from modern common rail.



# CONTENTS

## Credits

- Front cover: Image of Ferretti Yachts 940 courtesy of Ferretti Group
- Page 2: Image of Manhattan 68 courtesy of Sunseeker International
- Page 4 top: Image of Viking 54 courtesy of C&C Yachts Limited
- Page 4 bottom: Image of Bolide 80 courtesy of Victory Marine and Ranieri Tonissi
- Page 5: Image of X95 Vista courtesy of Princess Yachts Limited
- Page 17: Image of Pearl 72 courtesy of Pearl Yachts Limited
- Page 27: Image of Pershing GTX116 courtesy of Ferretti Group
- Page 33: Image of Riviera 72 Sports Motor Yacht Series II courtesy of Riviera Australia Pty Limited
- Page 42: Image of MCY 70 Skylounge courtesy of Monte Carlo Yachts
- Page 47: Image of Riva 82' Diva courtesy of Ferretti Group

Light Duty Operation . . . . . 4

## Description of Engines

i6-730, i6-800 and i6-850 . . . . .	6
V8-1000, V8-1120, V8-1200 and V8-1300 . . . . .	10
V12-1400 and V12-1550 . . . . .	18
V12-1650 and V12-1800 . . . . .	22
V12-1900 and V12-2000 . . . . .	28
V12X-2000 and V12X-2200 . . . . .	34
MAN Smart Hybrid Experience . . . . .	38
Exhaust Aftertreatment . . . . .	40
iSea Engine Electronic . . . . .	42
Extended Warranty . . . . .	44
MAN Service . . . . .	45
24/7 Hotline . . . . .	46
Pure Power . . . . .	47
Engine Range . . . . .	48



# LIGHT DUTY OPERATION.

## Characteristics

- Annual operating hours:  $\leq 1,000$
- Percentage of time at full load:  $\leq 20\%$
- Average load application:  $\leq 50\%$

## Typical applications

- Pleasure crafts
- Displacement yachts
- Sportfishing boats





# i6-730 / i6-800 / i6-850



## Characteristics

- Cylinders and arrangement:  
6 cylinders in line
- Operation mode: 4-stroke diesel engine,  
watercooled
- Turbocharging: Turbocharger with charge  
air intercooler and waste gate
- Number of valves: 4 valves per cylinder
- Fuel system: Common Rail direct fuel  
injection with electronic control
- Engine lubrication: Closed system with  
forced feeding, oil cooling and filtering
- Type of cooling: Heat exchanger with engine  
and seawater circuit
- Engine control: Electronic injection control  
(EDC), electronic engine monitoring including  
diagnostic unit
- Fuel: DIN EN 590

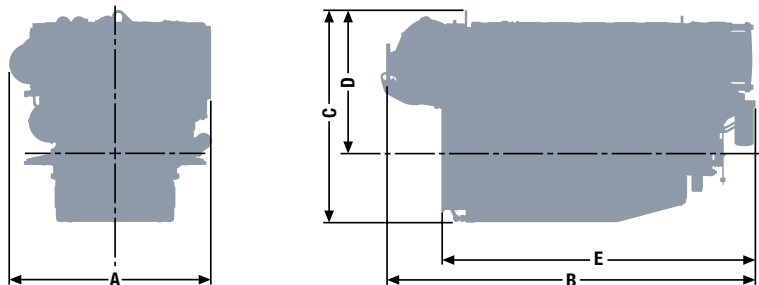

## Dimensions

Type designation	i6-730 / i6-800 / i6-850
A-Overall width	986 mm
B-Overall length	1,795 mm
C-Overall height – flat oil pan	1,036 mm
D-Top of engine to crankshaft centre	674 mm
E-Length of engine from front end to edge of flywheel housing	1,527 mm
Average weight of engine ready for installation (dry)	1,251 kg

For detailed examinations of installation dimensions, please order drawings from our factory.

## Technical features

Type designation	i6-730	i6-800	i6-850
Displacement	12.42 l	12.42 l	12.42 l
Maximum output to DIN ISO 3046-1	537 kW (730 hp)	588 kW (800 hp)	625 kW (850 hp)
Rated speed	2,300 rpm	2,300 rpm	2,300 rpm
Maximum torque	2,450 Nm	2,685 Nm	2,740 Nm
at speed	1,300–2,100 rpm	1,300–2,100 rpm	1,400–2,100 rpm
Absolute fuel consumption at rated power <sup>1)</sup>	146 l/h	156 l/h	163 l/h
Classifiable	✓	-	-
Exhaust gas status	IMO Tier II, EPA Tier 3, China 2 <sup>2)</sup> , RCD 2013/53/EC	IMO Tier II, EPA Tier 3, China 2 <sup>2)</sup> , RCD 2013/53/EC	IMO Tier II, EPA Tier 3 <sup>2)</sup> , China 2 <sup>2)</sup> , RCD 2013/53/EC

1) Tolerance +5% according to DIN ISO 3046-1

2) for private use only

# i6-730

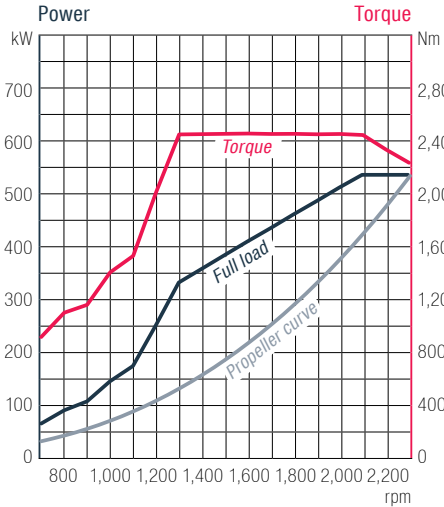

## Absolute fuel consumption

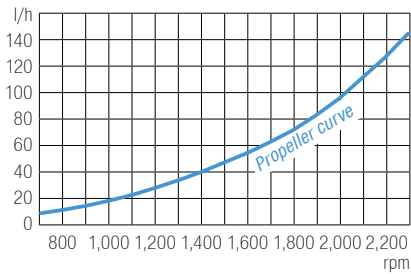

# i6-800

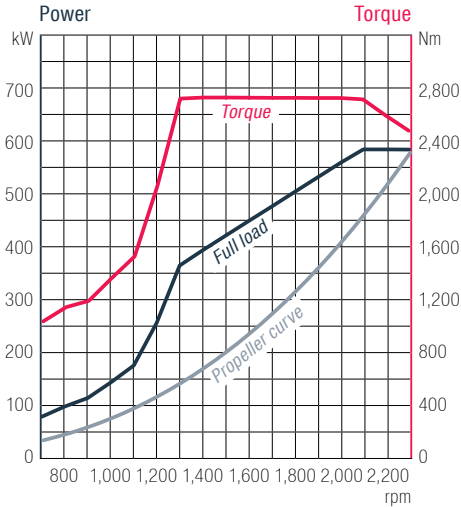

## Absolute fuel consumption

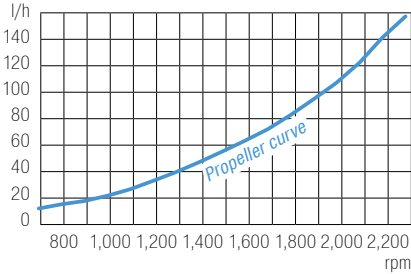

# i6-850

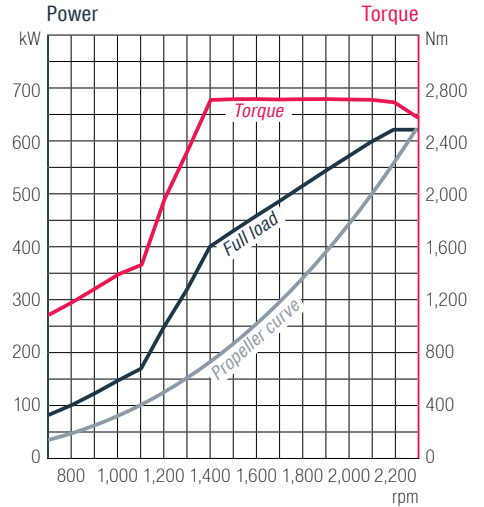

## Absolute fuel consumption

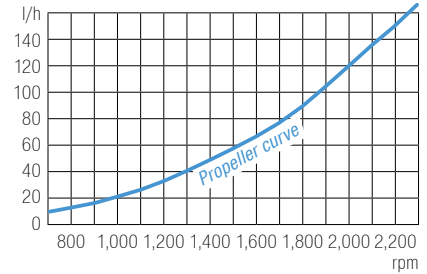

# V8-1000 / V8-1120 / V8-1200 / V8-1300



## Characteristics

- Cylinders and arrangement:  
8 cylinders in 90° V arrangement
- Operation mode: 4-stroke diesel engine, watercooled
- Turbocharging: Turbocharger with charge air intercooler and waste gate (1-stage: V8-1000, 2-stage: V8-1120, V8-1200 and V8-1300)
- Number of valves: 4 valves per cylinder
- Fuel system: Common Rail direct fuel injection with electronic control
- Engine lubrication: Closed system with forced feeding, oil cooling and filtering
- Type of cooling: Plate heat exchanger, seawater cooled
- Engine control: Electronic injection control (EDC), electronic engine monitoring including diagnostic unit
- Fuel: DIN EN 590

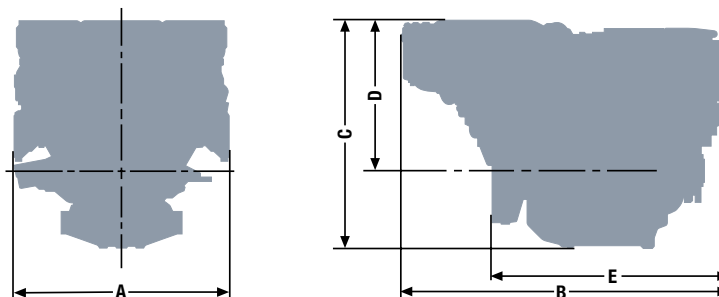

## Dimensions

Type designation	V8-1000	V8-1000 SCR	V8-1200 V8-1300	V8-1120
				V8-1200 V8-1300 SCR
A-Overall width	1,153 mm	1,157 mm	1,153 mm	1,181 mm
B-Overall length	1,745 mm	1,647 mm	1,736 mm	1,807 mm
C-Overall height – flat oil pan	1,177 mm	1,180 mm	1,222 mm	1,253 mm
D-Top of engine to crankshaft centre	765 mm	769 mm	811 mm	845 mm
E-Length of engine from front end to edge of flywheel housing	1,243 mm	1,251 mm	1,262 mm	1,286 mm
Average weight of engine ready for installation (dry)	1,780 kg	1,780 kg	1,941 kg	1,941 mm

For detailed examinations of installation dimensions, please order drawings from our factory.

## Technical features

Type designation	V8-1000	V8-1000 SCR	V8-1120 SCR
Displacement	16.16 l	16.16 l	16.16 l
Maximum output to DIN ISO 3046-1	735 kW (1,000 hp)	735 kW (1,000 hp)	824 kW (1,120 hp)
Rated speed	2,300 rpm	2,300 rpm	2,300 rpm
Maximum torque	3,345 Nm	3,345 Nm	3,710 Nm
at speed	1,400–2,100 rpm	1,300–2,100 rpm	1,200–2,100 rpm
Absolute fuel consumption at rated power <sup>1)</sup>	205 l/h	202 l/h	200 l/h
Classifiable	-	✓	✓
Exhaust gas aftertreatment	-	✓	✓
Exhaust gas status	IMO Tier II, China 2 <sup>2)</sup> , RCD 2013/53/EC	IMO Tier III, EPA Tier 3 <sup>2)</sup>	IMO Tier III, EPA Tier 4

1) Tolerance +5% according to DIN ISO 3046-1

2) for private use only

# V8-1000

# V8-1000 SCR

# V8-1120 SCR

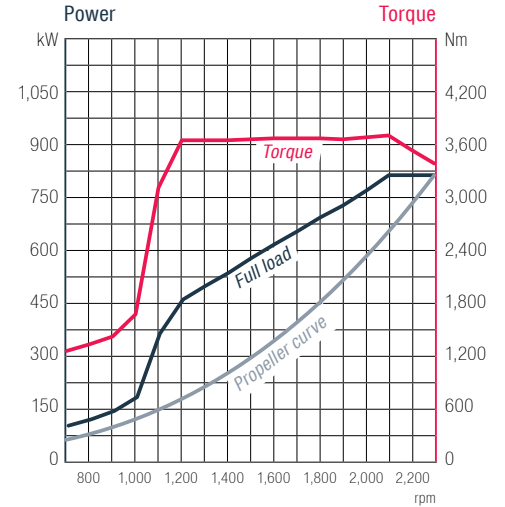
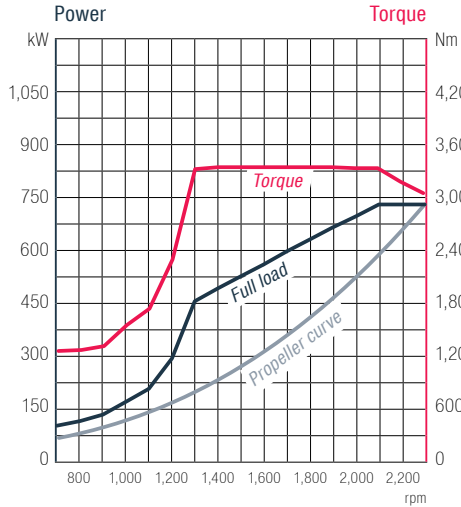
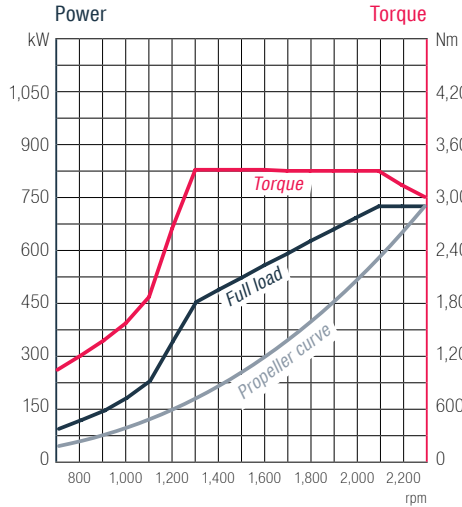

## Absolute fuel consumption

## Absolute fuel consumption

## Absolute fuel consumption

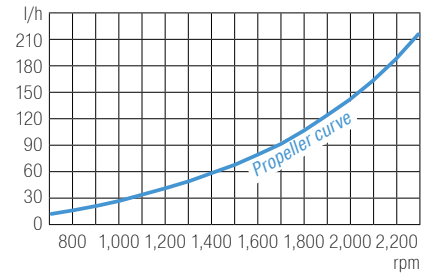
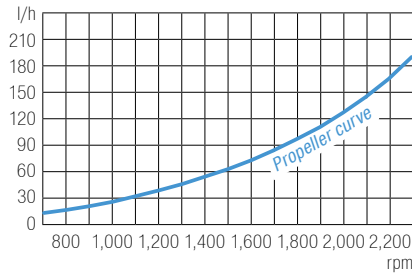
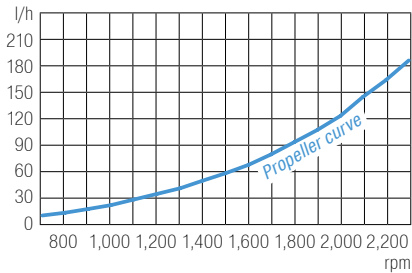

## Technical features

Type designation	V8-1200	V8-1200 SCR	V8-1300	V8-1300 SCR
Displacement	16.16 l	16.16 l	16.16 l	16.16 l
Maximum output to DIN ISO 3046-1	882 kW (1,200 hp)	882 kW (1,200 hp)	956 kW (1,300 hp)	956 kW (1,300 hp)
Rated speed	2,300 rpm	2,300 rpm	2,300 rpm	2,300 rpm
Maximum torque	4,010 Nm	4,005 Nm	4,350 Nm	4,230 Nm
at speed	1,200–2,100 rpm	1,300–2,100 rpm	1,300–2,100 rpm	1,300–2,100 rpm
Absolute fuel consumption at rated power <sup>1)</sup>	242 l/h	197 l/h	256 l/h	200 l/h
Classifiable	-	✓	-	-
Exhaust gas aftertreatment	-	✓	-	✓
Exhaust gas status	IMO Tier II, EPA Tier 3 <sup>2)</sup> , China 2 <sup>2)</sup> , RCD 2013/53/EC	IMO Tier III, EPA Tier 3 <sup>2)</sup>	IMO Tier II, EPA Tier 3 <sup>2)</sup> , China 2 <sup>2)</sup> , RCD 2013/53/EC	IMO Tier III, EPA Tier 3 <sup>2)</sup>

1) Tolerance +5% according to DIN ISO 3046-1

2) for private use only

# V8-1200

# V8-1200 SCR

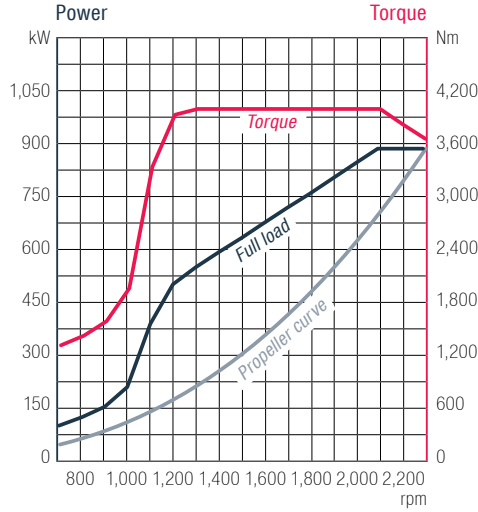
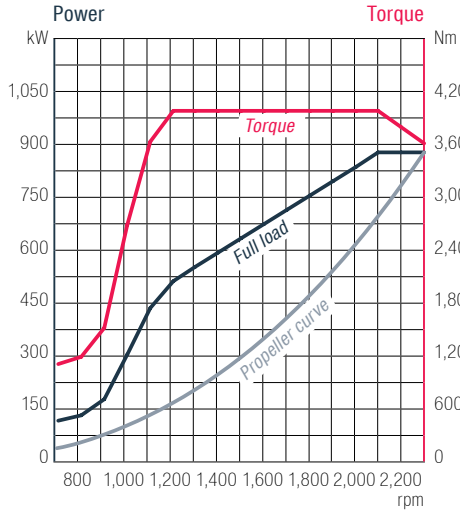

Absolute fuel consumption

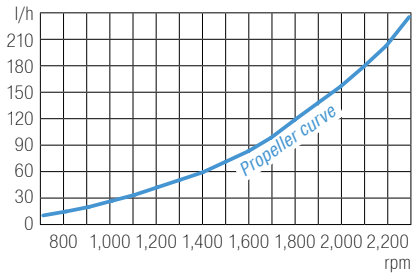

Absolute fuel consumption

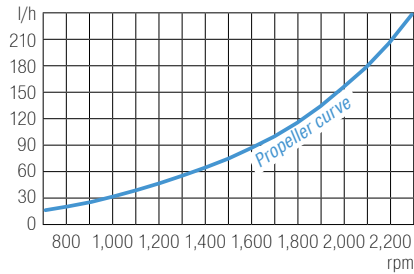

# V8-1300

# V8-1300 SCR

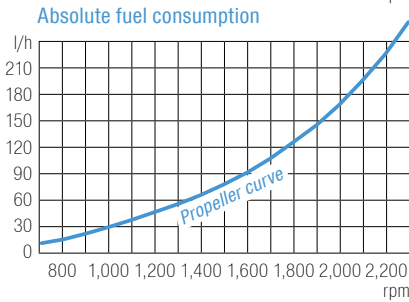
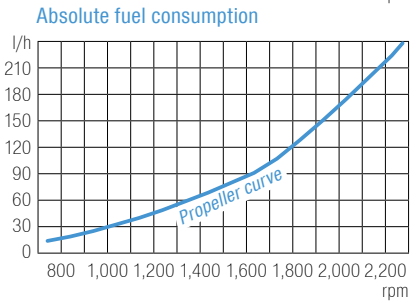
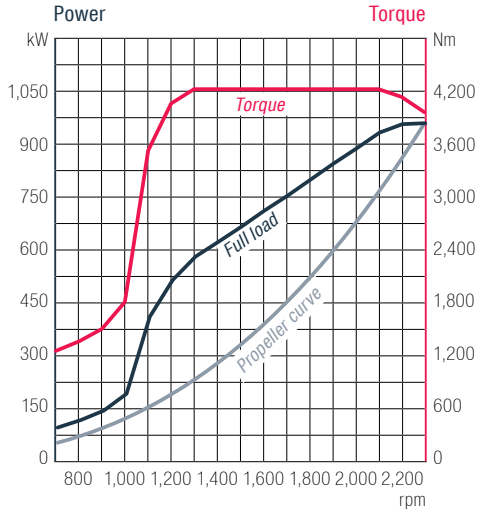
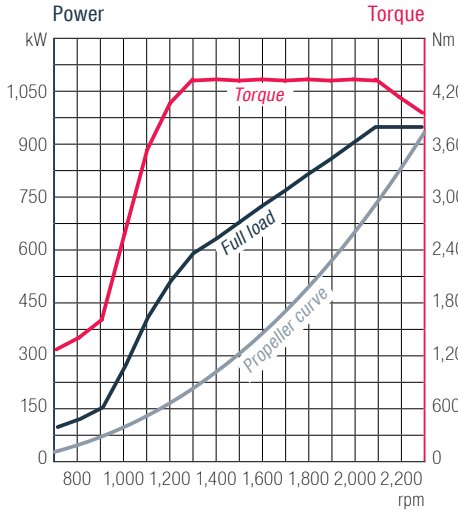



## V12-1400 / V12-1550



## Characteristics

- Cylinders and arrangement:  
12 cylinders in 90° V arrangement
- Operation mode: 4-stroke diesel engine, watercooled
- Turbocharging: Turbocharger with charge air intercooler and waste gate (1-stage: V12-1400 and V12-1550, 2-stage: V12-1550 with SCR)
- Number of valves: 4 valves per cylinder
- Fuel system: Common Rail direct fuel injection with electronic control
- Engine lubrication: Closed system with forced feeding, oil cooling and filtering
- Type of cooling: Plate heat exchanger, seawater cooled
- Engine control: Electronic injection control (EDC), electronic engine monitoring including diagnostic unit
- Fuel: DIN EN 590

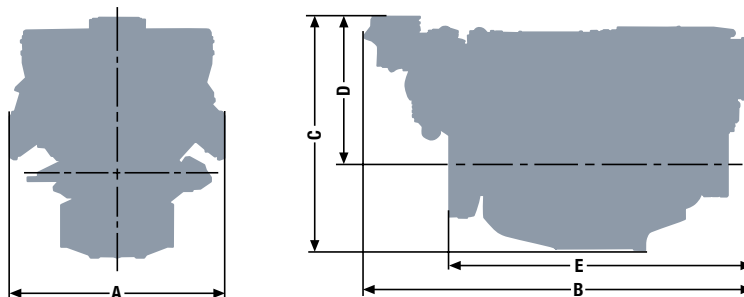

## Dimensions

Type designation	V12-1400 V12-1550	V12-1550 SCR
A-Overall width	1,153 mm	1,153 mm
B-Overall length	2,130 mm	2,139 mm
C-Overall height – flat oil pan	1,230 mm	1,272 mm
D-Top of engine to crankshaft centre	765 mm	808 mm
E-Length of engine from front end to edge of flywheel housing	1,630 mm	1,658 mm
Average weight of engine ready for installation (dry)	2,270 kg	2,420 kg

For detailed examinations of installation dimensions, please order drawings from our factory.

## Technical features

Type designation	V12-1400	V12-1550	V12-1550 SCR
Displacement	24.24 l	24.24 l	24.24 l
Maximum output to DIN ISO 3046-1	1,029 kW (1,400 hp)	1,140 kW (1,550 hp)	1,140 kW (1,550 hp)
Rated speed	2,300 rpm	2,300 rpm	2,300 rpm
Maximum torque	4,680 Nm	5,185 Nm	5,180 Nm
at speed	1,200–2,100 rpm	1,200–2,100 rpm	1,200–2,100 rpm
Absolute fuel consumption at rated power <sup>1)</sup>	270 l/h	301 l/h	307 l/h
Classifiable	✓	-	-
Exhaust gas aftertreatment	-	-	✓
Exhaust gas status	IMO Tier II, EPA Tier 3 <sup>2)</sup> , China 2 <sup>2)</sup> , RCD 2013/53/EC	IMO Tier II, EPA Tier 3 <sup>2)</sup> , China 2 <sup>2)</sup> , RCD 2013/53/EC	IMO Tier III, EPA Tier 3 <sup>2)</sup>

1) Tolerance +5% according to DIN ISO 3046-1

2) for private use only

# V12-1400

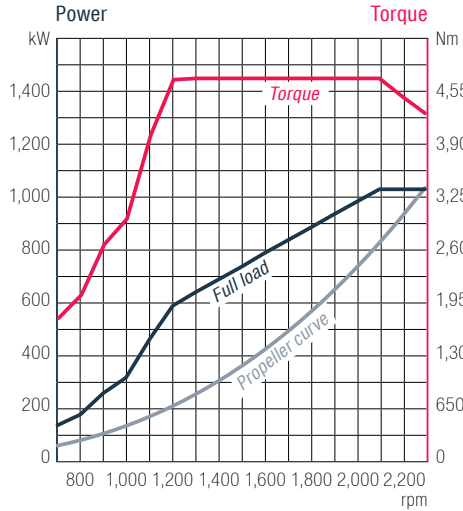

Absolute fuel consumption

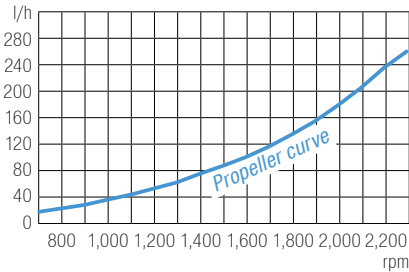

# V12-1550

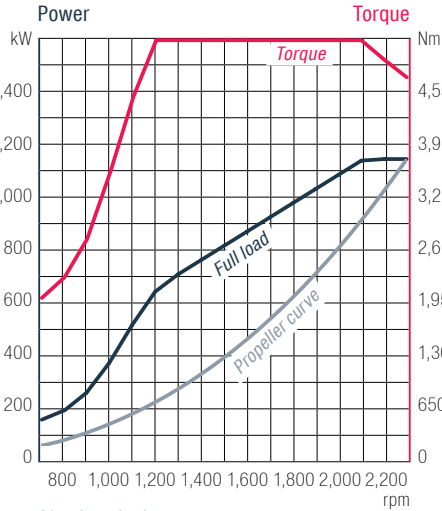

Absolute fuel consumption

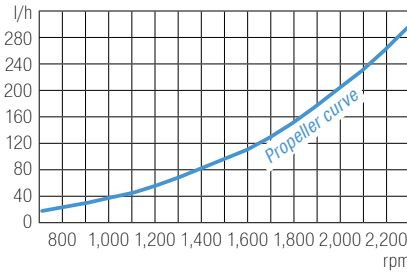

# V12-1550 SCR

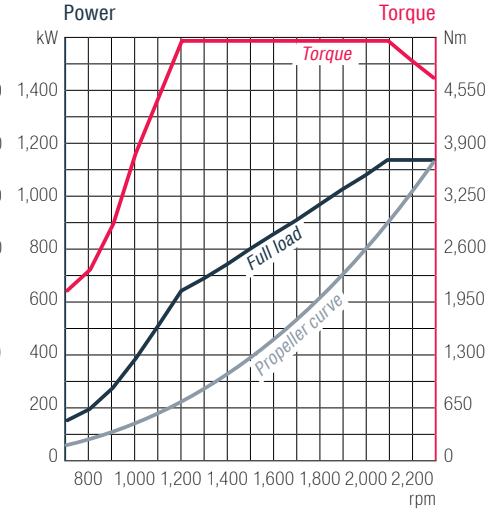

Absolute fuel consumption

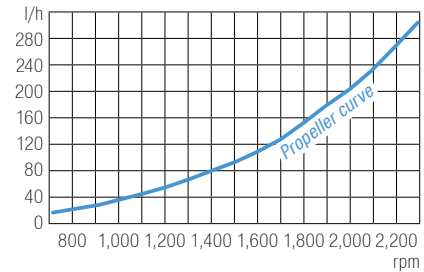

# V12-1650 / V12-1800

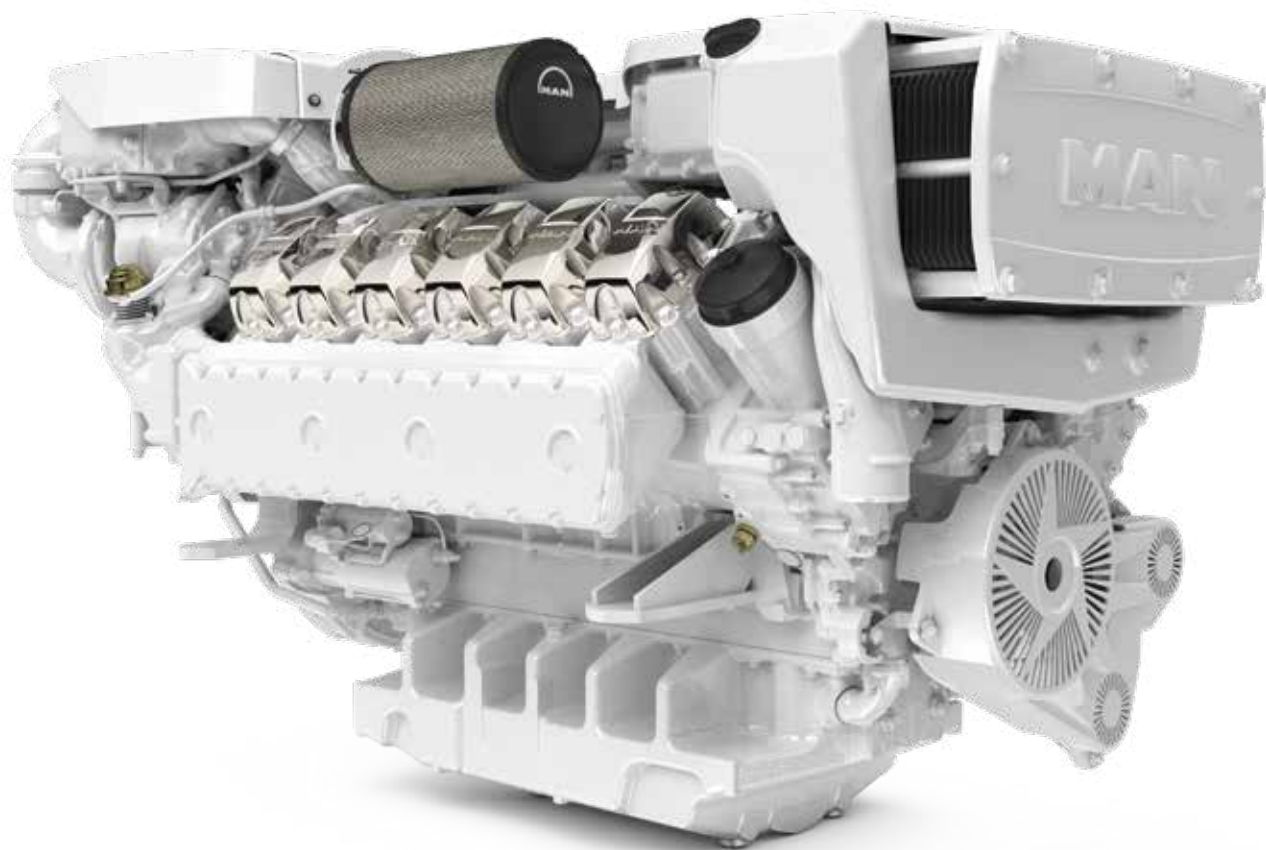

## Characteristics

- Cylinders and arrangement:  
12 cylinders in 90° V arrangement
- Operation mode:  
4-stroke diesel engine, watercooled
- Turbocharging: 2-stage turbocharger with charge air intercooler and waste gate
- Number of valves: 4 valves per cylinder
- Fuel system: Common Rail direct fuel injection with electronic control
- Engine lubrication: Closed system with forced feeding, oil cooling and filtering
- Type of cooling: Plate heat exchanger, seawater cooled
- Engine control: Electronic injection control (EDC), electronic engine monitoring including diagnostic unit
- Fuel: DIN EN 590

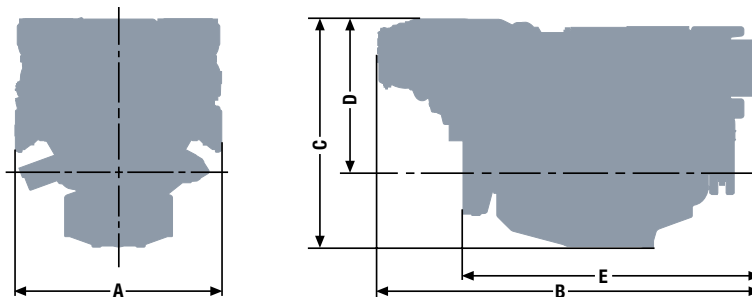

## Dimensions

Type designation	V12-1650/V12-1800
A-Overall width	1,153 mm
B-Overall length	2,139 mm
C-Overall height – flat oil pan	1,272 mm
D-Top of engine to crankshaft centre	808 mm
E-Length of engine from front end to edge of flywheel housing	1,658 mm
Average weight of engine ready for installation (dry)	2,420 kg

For detailed examinations of installation dimensions, please order drawings from our factory.

## Technical features

Type designation	V12-1650	V12-1650 SCR	V12-1800	V12-1800 SCR
Displacement	24.24 l	24.24 l	24.24 l	24.24 l
Maximum output to DIN ISO 3046-1	1,213 kW (1,650 hp)	1,213 kW (1,650 hp)	1,324 kW (1,800 hp)	1,324 kW (1,800 hp)
Rated speed	2,300 rpm	2,300 rpm	2,300 rpm	2,300 rpm
Maximum torque	5,510 Nm	5,518 Nm	6,010 Nm	6,010 Nm
at speed	1,200–2,100 rpm	1,200–2,100 rpm	1,200–2,100 rpm	1,200–2,100 rpm
Absolute fuel consumption at rated power <sup>1)</sup>	319 l/h	325 l/h	355 l/h	351 l/h
Classifiable	✓	✓	-	-
Exhaust gas aftertreatment	-	✓	-	✓
Exhaust gas status	IMO Tier II, EPA Tier 3 <sup>2)</sup> , China 2, RCD 2013/53/EC	IMO Tier III, EPA Tier 3 <sup>2)</sup>	IMO Tier II, EPA Tier 3 <sup>2)</sup> , China 2 <sup>2)</sup> , RCD 2013/53/EC	IMO Tier III, EPA Tier 3 <sup>2)</sup>

1) Tolerance +5% according to DIN ISO 3046-1

2) for private use only

# V12-1650

# V12-1650 SCR

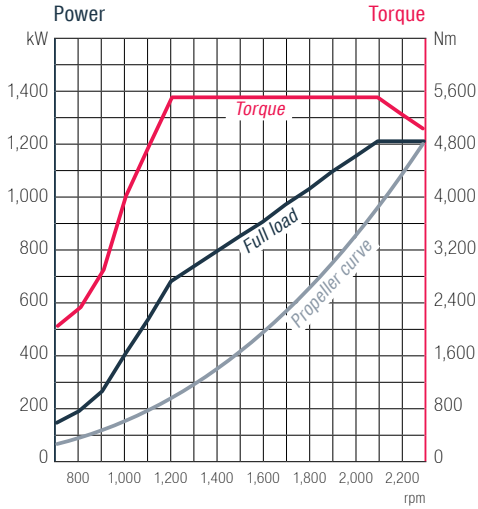
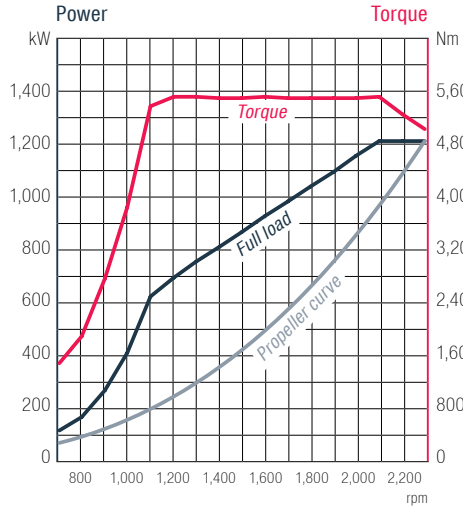

## Absolute fuel consumption

## Absolute fuel consumption

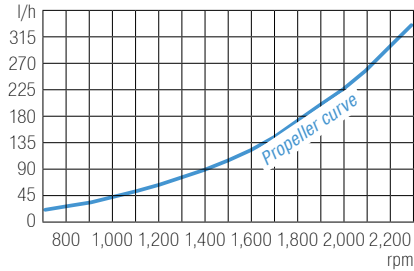
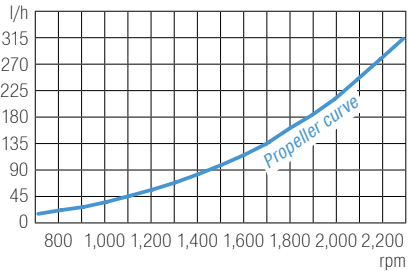

# V12-1800

# V12-1800 SCR

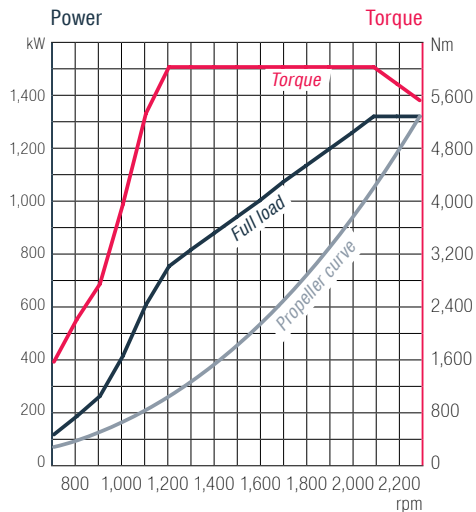

Absolute fuel consumption

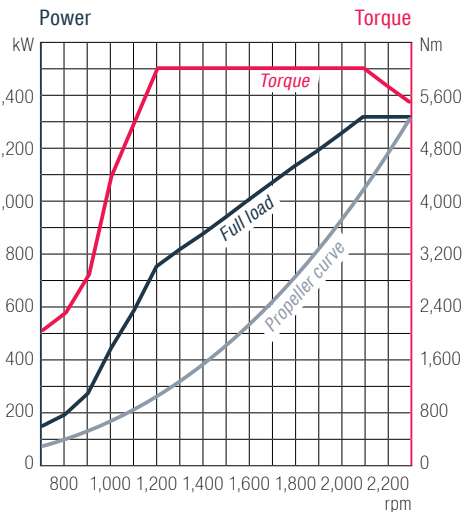
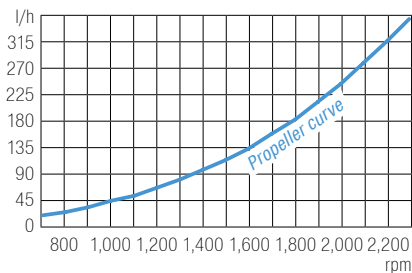

Absolute fuel consumption

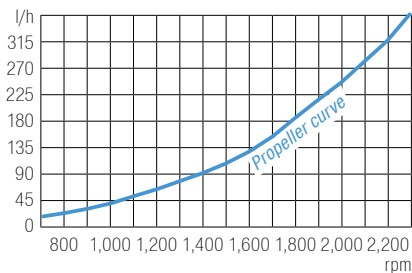



# V12-1900 / V12-2000



## Characteristics

- Cylinders and arrangement:  
12 cylinders in 90° V arrangement
- Operation mode:  
4-stroke diesel engine, watercooled
- Turbocharging: Turbocharger with charge air intercooler and waste gate
- Number of valves: 4 valves per cylinder
- Fuel system: Common Rail direct fuel injection with electronic control
- Engine lubrication: Closed system with forced feeding, oil cooling and filtering
- Type of cooling: Plate heat exchanger, seawater cooled
- Engine control: Electronic injection control (EDC), electronic engine monitoring including diagnostic unit
- Fuel: DIN EN 590

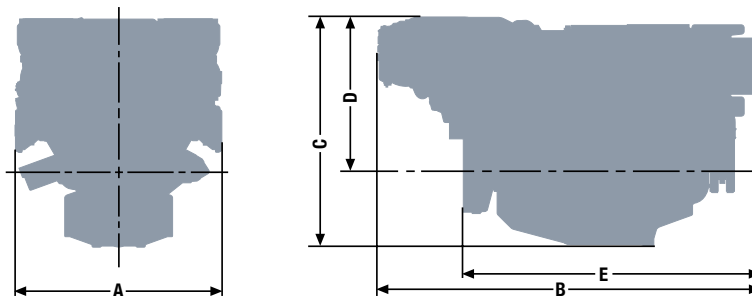

## Dimensions

Type designation	V12-1900/V12-2000
A-Overall width	1,153 mm
B-Overall length	2,139 mm
C-Overall height – flat oil pan	1,272 mm
D-Top of engine to crankshaft centre	808 mm
E-Length of engine from front end to edge of flywheel housing	1,658 mm
Average weight of engine ready for installation (dry)	2,420 kg

For detailed examinations of installation dimensions, please order drawings from our factory.

## Technical features

Type designation	V12-1900	V12-1900 SCR	V12-2000	V12-2000 SCR
Displacement	24.24 l	24.24 l	24.24 l	24.24 l
Maximum output to DIN ISO 3046-1	1,397 kW (1,900 hp)	1,397 kW (1,900 hp)	1,471 kW (2,000 hp)	1,471 kW (2,000 hp)
Rated speed	2,300 rpm	2,300 rpm	2,300 rpm	2,300 rpm
Maximum torque	6,130 Nm	6,185 Nm	6,460 Nm	6,508 Nm
at speed	1,200–2,100 rpm	1,200–2,100 rpm	1,200–2,100 rpm	1,200–2,100 rpm
Absolute fuel consumption at rated power <sup>1)</sup>	373 l/h	374 l/h	399 l/h	396 l/h
Classifiable	-	-	-	-
Exhaust gas aftertreatment	-	✓	-	✓
Exhaust gas status	IMO Tier II, EPA Tier 3 <sup>2)</sup> , China 2 <sup>2)</sup> , RCD 2013/53/EC	IMO Tier III, EPA Tier 3 <sup>2)</sup>	IMO Tier II, EPA Tier 3 <sup>2)</sup> , China 2 <sup>2)</sup> , RCD 2013/53/EC	IMO Tier III, EPA Tier 3 <sup>2)</sup>

1) Tolerance +5% according to DIN ISO 3046-1

2) for private use only

# V12-1900

# V12-1900 SCR

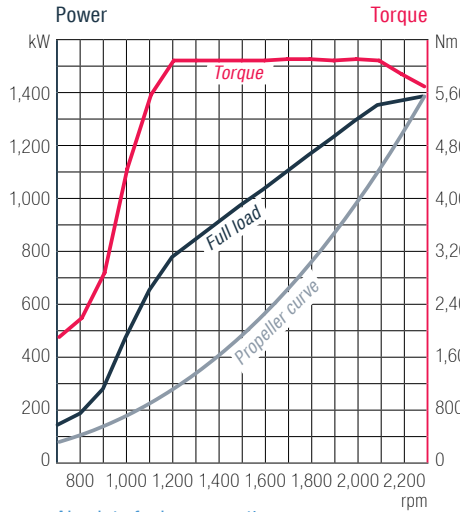

Absolute fuel consumption

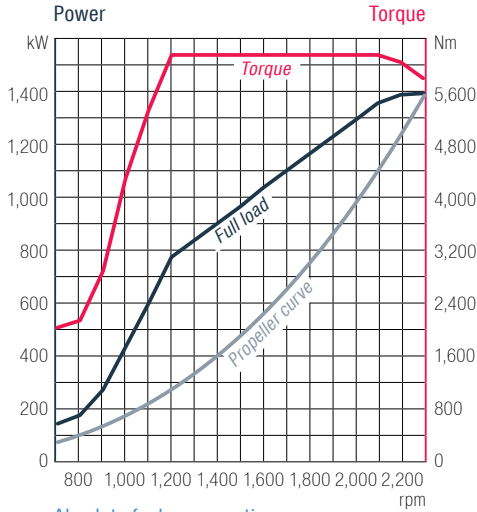
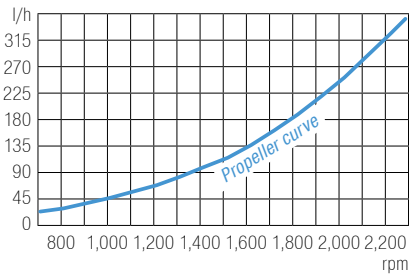

Absolute fuel consumption

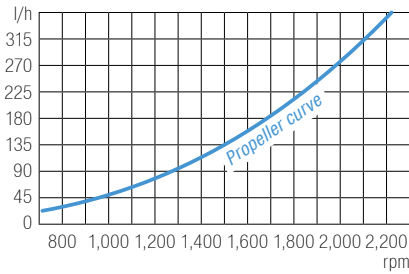

# V12-2000

# V12-2000 SCR

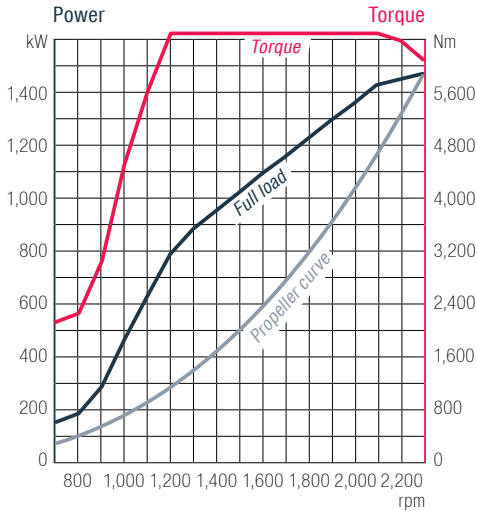
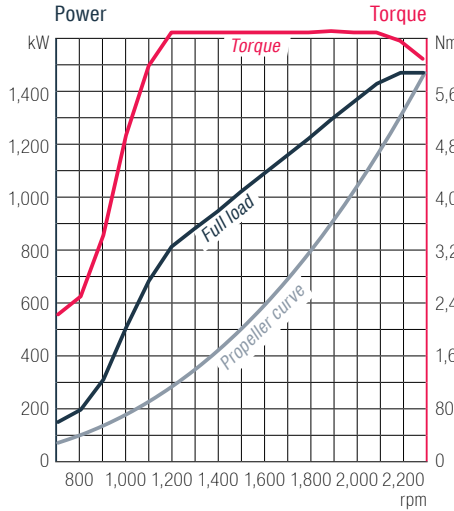

Absolute fuel consumption

Absolute fuel consumption

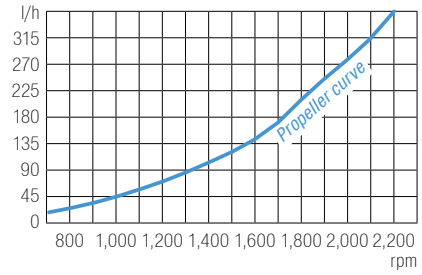
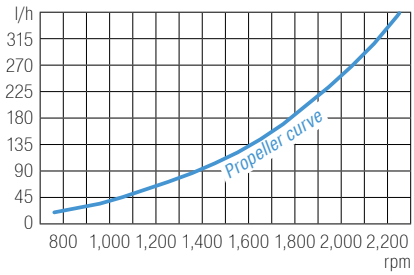



# V12X-2000 / V12X-2200

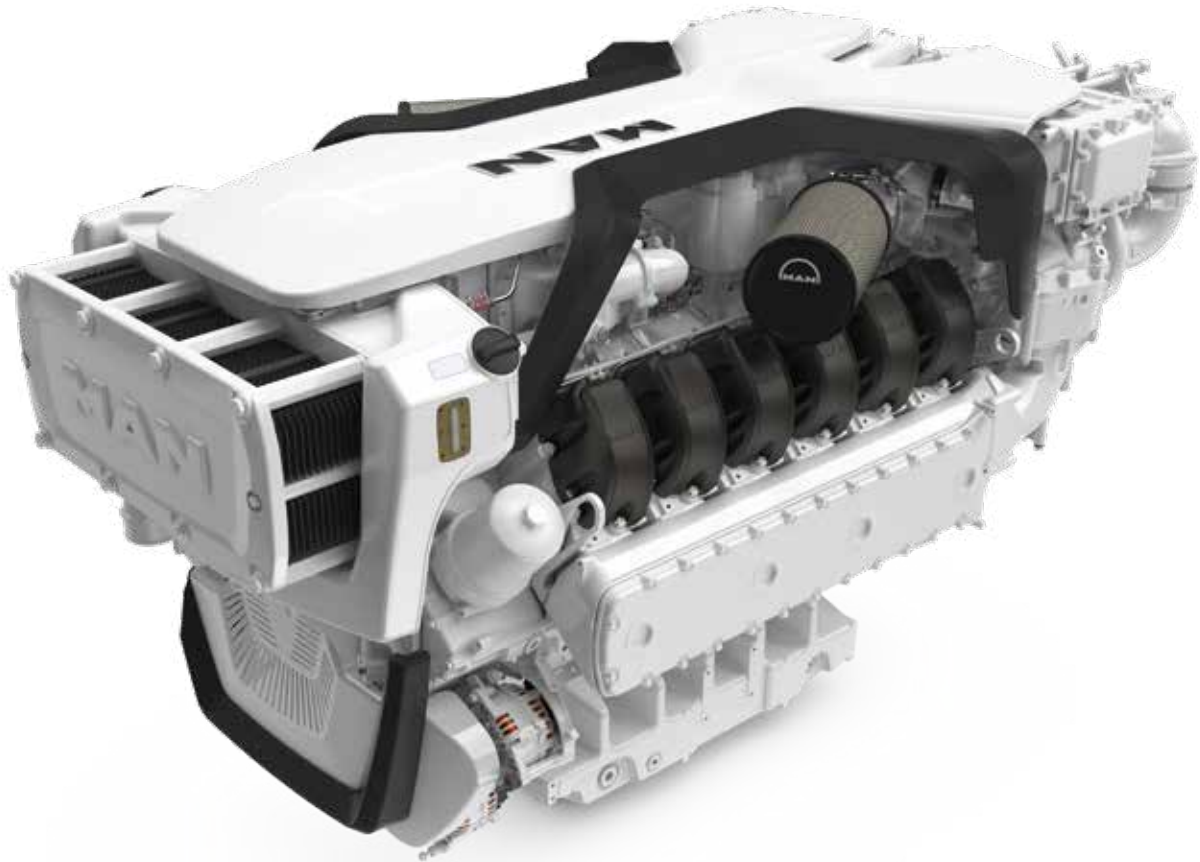

## Characteristics

- Cylinders and arrangement:  
12 cylinders in 90° V arrangement
- Operation mode:  
4-stroke diesel engine, watercooled
- Turbocharging: Turbocharger with charge air intercooler and waste gate
- Number of valves: 4 valves per cylinder
- Fuel system: Common Rail direct fuel injection with electronic control
- Engine lubrication: Closed system with forced feeding, oil cooling and filtering
- Type of cooling: Plate heat exchanger, seawater cooled
- Engine control: Electronic injection control (EDC), electronic engine monitoring including diagnostic unit
- Fuel: DIN EN 590

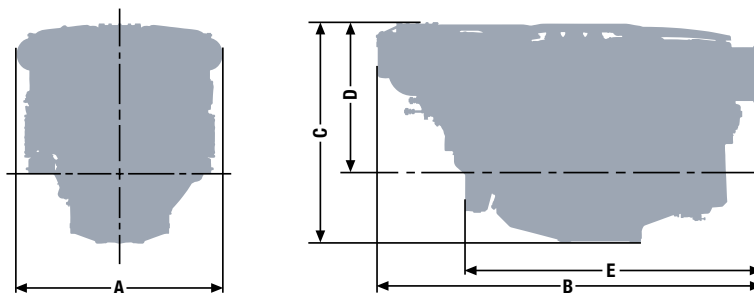

## Dimensions

Type designation	V12X-2000/V12X-2200
A-Overall width	1,157 mm
B-Overall length	2,374 mm
C-Overall height – flat oil pan	1,328 mm
D-Top of engine to crankshaft centre	863 mm
E-Length of engine from front end to edge of flywheel housing	1,792 mm
Average weight of engine ready for installation (dry)	2,700 kg

For detailed examinations of installation dimensions, please order drawings from our factory.

## Technical features

Type designation	V12X-2000	V12X-2200
Displacement	29.62 l	29.62 l
Maximum output to DIN ISO 3046-1	1,471 kW (2,000 hp)	1,618 kW (2,200 hp)
Rated speed	2,300 rpm	2,300 rpm
Maximum torque	6,589 Nm	7,358 Nm
at speed	1,200–2,100 rpm	1,200–2,100 rpm
Absolute fuel consumption at rated power <sup>1)</sup>	370 l/h	412 l/h
Classifiable	✓	-
Exhaust gas aftertreatment	-	-
Exhaust gas status	IMO Tier II, EPA Tier 3 <sup>2)</sup>	IMO Tier II, EPA Tier 3 <sup>2)</sup>

1) Tolerance +5% according to DIN ISO 3046-1

2) for private use only

# V12X-2000

# V12X-2200

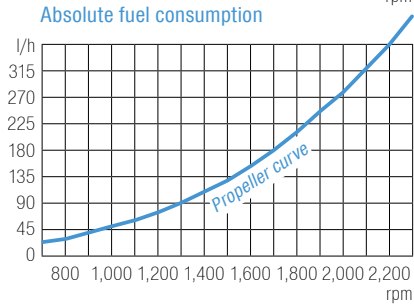
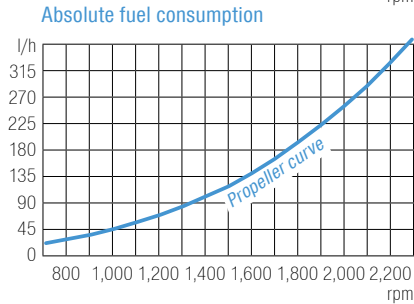
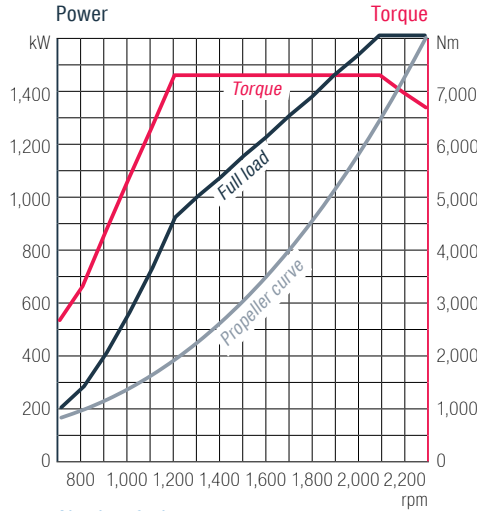
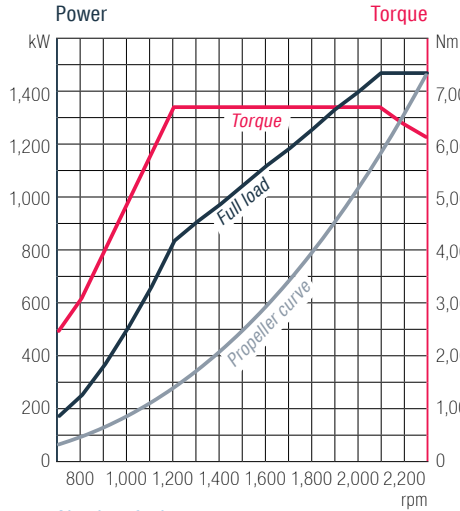

# MAN SMART HYBRID EXPERIENCE.

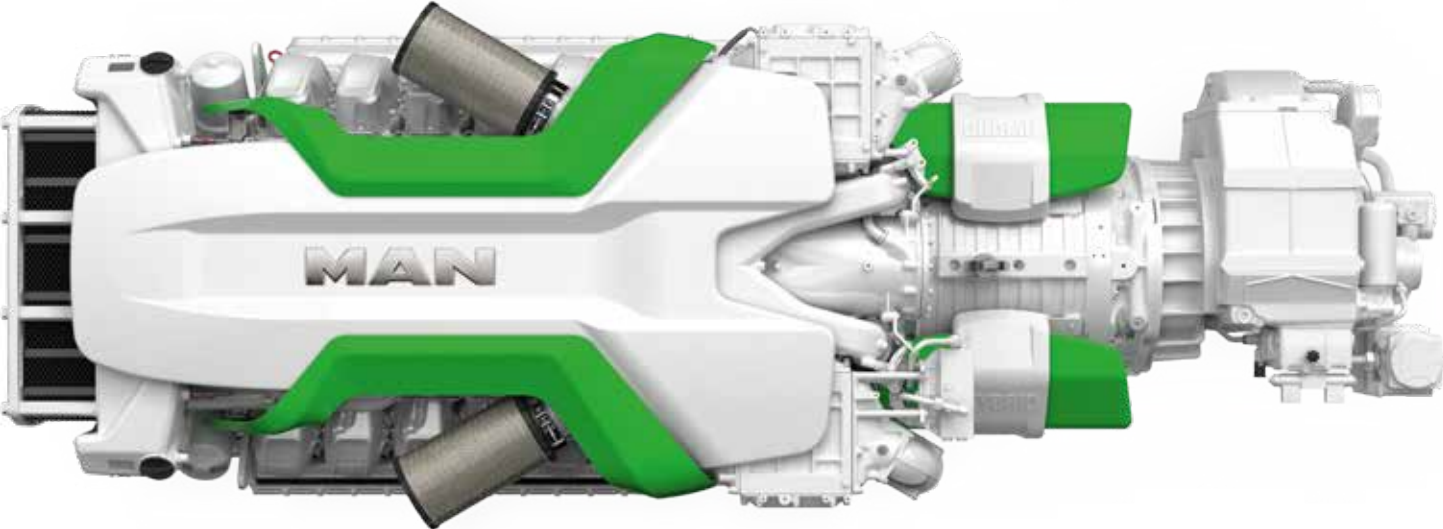

## Change of mobility on the water

MAN Engines is ushering in a new era of zero-emission mobility, maximum performance based on intelligent solutions, and comfortable cruising for marine engines. The modular MAN Smart Hybrid Experience is tailored to your individual needs and wishes and is specifically configured with this in mind. The ability to flexibly combine conventional marine engines and electric motors with batteries and on-board units opens up countless opportunities for incorporating different degrees of hybrid power in leisure craft as well as commercial applications. Based on the desired operating modes, the MAN hybrid system can focus the driving profiles on performance, comfort or efficiency.

MAN Engines offers you a tailored solution for your specific hybrid needs.

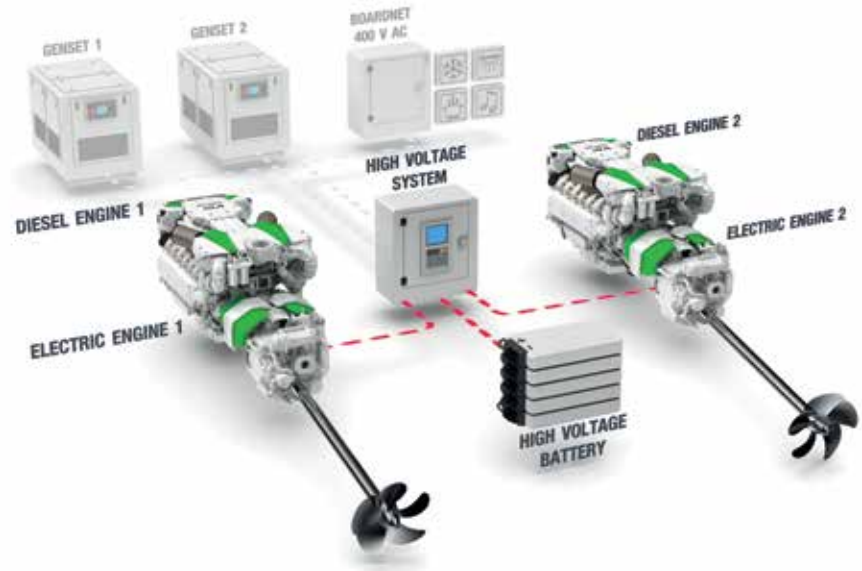

 Please get in touch with our numerous operating modes!



# EXHAUST AFTERTREATMENT.

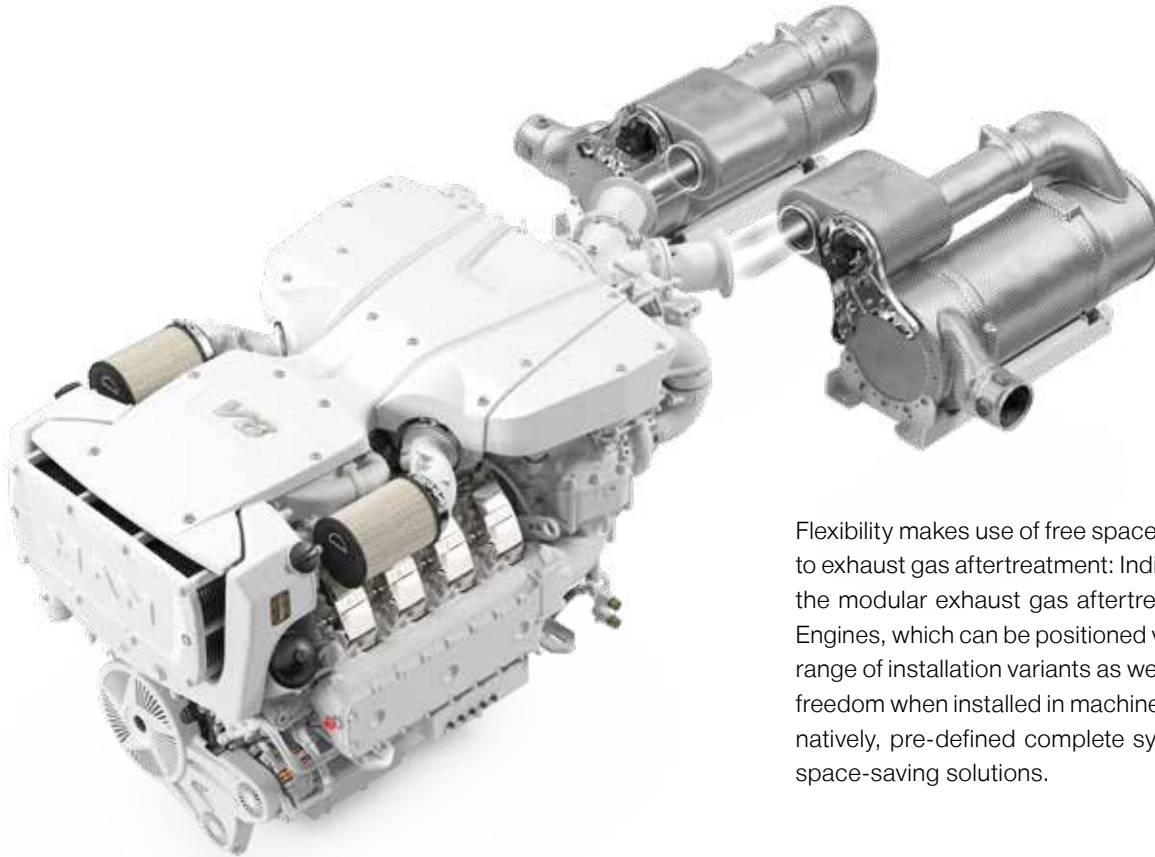

Flexibility makes use of free space – also when it comes to exhaust gas aftertreatment: Individual components of the modular exhaust gas aftertreatment kit from MAN Engines, which can be positioned variably, enable a wide range of installation variants as well as maximum design freedom when installed in machinery and vehicles. Alternatively, pre-defined complete systems offer practical, space-saving solutions.

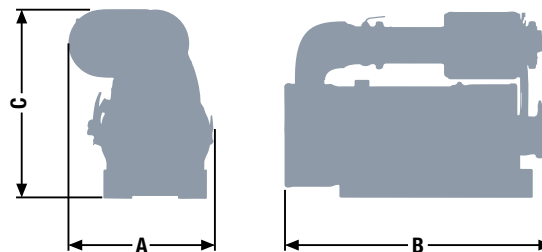

## Dimensions

SCR system	IMO Tier III, EPA Tier 4 (<1066 kW)	IMO Tier III (1140–1397 kW)
A-Overall width	555 mm	669 mm
B-Overall length	950 mm	1,102 mm
C-Overall height	663 mm	615 mm
Average weight of SCR system	115 kg	135 kg

For detailed examinations of installation dimensions, please order drawings from our factory.



## iSEA ENGINE ELECTRONIC.

**iSea** Intelligent monitoring of engines, gearboxes and exhaust gas aftertreatment on pleasure crafts and sportfishing boats – that's iSea (intelligent safeguards of engines and auxiliaries) from MAN Engines. iSea provides state of the art technology but still looks good – with the optional iSea bridge display. With its numerous connection options and interfaces it is the ideal solution for use on the world's limitless oceans. All the MAN Engines components are perfectly coordinated and intuitively designed. iSea is the future that gives you the best view of the present



## Throttle lever

A modern classic, the MAN throttle lever for single or multiple engine systems is used in various drive concepts, as well as in hybrid drives. Different modes can be selected at the push of a button. The MAN throttle lever makes sailing and docking more efficient than ever before.

- A perfectly coordinated system offering excellent fuel savings and system reliability
- Better running properties and increased convenience thanks to ergonomic, high quality operator controls
- Less space required thanks to integration of the controller into the iSea box



## Benefits

- Modern multifunction touch screen display (7" or 10")
  - Maximum space savings thanks to visualisation of 7 peripherals on a single display: instrumentation, alarm handling, start/stop panel, emergency drive, CAN converter, video screen, digital I/O
  - Reduction in number of cables thanks to proven CAN bus wiring
-



# EXTENDED WARRANTY.

You have nothing to worry about with the MAN Gold Standard Premium (GSP). The extended warranty protects you against unexpected repair costs of all your MAN branded engine room components, including cost-intensive components such as electronics and turbochargers. And because MAN's GSP is transferable, you're safe in the knowledge that you're not only protecting your investment but maximising its resale value at the same time.

In addition to the warranty ex works (two years) you have the option of taking out additional coverage for yourself and your investment: Gold Standard Premium gives you the option of extending the original warranty for three more years, meaning a total warranty period of five years. For the additional three years, the warranty can be concluded for another 2,500 or 4,000 operating hours. All engine components are completely covered.



---

## Benefits

- Coverage of all MAN components in your engine room
  - Transferability to subsequent owners increases the resale value
  - Peace of mind beyond the standard warranty
  - Protects your investment against unplanned repairs
  - Remaining flexible because you can opt for the warranty extension within the first two years
  - Adaptable to your needs and lifestyle (2,500 or 4,000 hours)
  - All maintenance performed by authorized MAN service partners
  - Only MAN Genuine Parts are used
-

# MAN SERVICE.



**Worldwide service network**  
most certainly represented in your area



**Spare parts availability**  
worldwide available within 24 hours



**Extended warranty**  
up to 5 years Gold Standard Premium



**MAN Customer Service**  
as back-up from the headquarters



**MAN 24/7 Hotline**  
available 24 hours a day, 365 days a year



**Servicing and maintenance plans**  
individually for you



**MAN Genuine Oil**  
customised for MAN engines



**MAN Engine Academy**  
for a deeper understanding of engines



# 24/7 HOTLINE.



With its 24/7 service hotline for marine engines, MAN Engines now provides even easier access to its extensive global service network. Trained employees ensure that an expert service workshop close to you will deal with your concern and will remain in close contact with you. If your MAN marine engine has a service case, you can receive support by phone right away at the 24/7 hotline with the following telephone numbers. Please have your engine number ready. You can find this on every engine model plate, in your maintenance record and in the registration papers.



## Benefits

- Available round the clock, 365 days a year
- Free referral to a MAN service outlet
- Access to almost 500 service stations
- Continuous support until the service case is concluded

**North and Latin America:**

**+1 754 238 6313**

**The rest of the world:**

**+49 911 420 420**

Please note that you may incur costs when ringing the American or German landline number.

# PURE POWER.

---



## Benefits

- High tractive power even at low speeds
  - Powerful acceleration and rapid reaction to commands
  - High performance combined with low weight
  - Compact, space-saving design
  - High efficiency with low fuel consumption
  - Low running costs and long service life
  - Low emission values
  - World-wide service network with rapid supply of spare parts
  - Continuous 24/7 hotline support around the clock, 365 days a year
- 



# ENGINE RANGE.

Characteristics	i6			V8			
	730	800	850	1000	1000 SCR	1120 SCR	
Type designation							
Arrangement and number of cylinders	R6	R6	R6	V8	V8	V8	
Nominal rating	hp	730	800	850	1,000	1,000	1,120
Maximum torque	Nm	2,450	2,674	2,845	3,340	3,345	3,710
Engine classifiable		✓	-	-	-	✓	✓
Rated speed	rpm	2,300	2,300	2,300	2,300	2,300	2,300
Fuel consumption	l/h	146	156	163	205	202	200
Bore/Stroke	mm	126/166	126/166	126/166	128/157	128/157	128/157
Displacement	l	12.42	12.42	12.42	16.16	16.16	16.6
Length of engine from front end to edge of flywheel housing	mm	1,527	1,527	1,527	1,243	1,251	1,251
Width	mm	986	986	986	1,153	1,157	1,157
Height	mm	1,036	1,036	1,036	1,177	1,180	1,180
Dry weight	kg	1,251	1,251	1,251	1,780	1,780	1,780
Exhaust gas aftertreatment		-	-	-	-	✓	✓
Exhaust gas status		<b>A</b>	<b>A</b>	<b>B</b>	<b>C</b>	<b>D</b>	<b>E</b>

**A** IMO Tier II, EPA Tier 3, China 2 for private use only, RCD 2013/53/EC  
**B** IMO Tier II, EPA Tier 3 for private use only, China 2 for private use only, RCD 2013/53/EC

**C** IMO Tier II, China 2 for private use only, RCD 2013/53/EC  
**D** IMO Tier III, EPA Tier 3 for private use only  
**E** IMO Tier III, EPA Tier 4

Characteristics		V8				V12
		1200	1200 SCR	1300	1300 SCR	1400
Type designation		V8	V8	V8	V8	V12
Arrangement and number of cylinders		V8	V8	V8	V8	V12
Nominal rating	hp	1,200	1,200	1,300	1,300	1,400
Maximum torque	Nm	4,010	4,005	4,350	4,230	4,680
Engine classifiable		-	✓	-	-	✓
Rated speed	rpm	2,300	2,300	2,300	2,300	2,300
Fuel consumption	l/h	242	197	256	200	270
Bore/Stroke	mm	128/157	128/157	128/157	128/157	128/157
Displacement	l	16.16	16.16	16.16	16.16	24.24
Length of engine from front end to edge of flywheel housing	mm	1,262	1,286	1,262	1,286	1,630
Width	mm	1,153	1,181	1,153	1,181	1,153
Height	mm	1,222	1,253	1,222	1,253	1,230
Dry weight	kg	1,941	1,941	1,941	1,941	2,270
Exhaust gas aftertreatment		-	✓	-	✓	-
Exhaust gas status		<b>B</b>	<b>D</b>	<b>B</b>	<b>D</b>	<b>B</b>

**B** IMO Tier II, EPA Tier 3 for private use only, China 2 for private use only, RCD 2013/53/EC

**D** IMO Tier III, EPA Tier 3 for private use only

# ENGINE RANGE.

Characteristics	V12						
		1550	1550 SCR	1650	1650 SCR	1800	1800 SCR
Type designation							
Arrangement and number of cylinders		V12	V12	V12	V12	V12	V12
Nominal rating	hp	1,550	1,550	1,650	1,650	1,800	1,800
Maximum torque	Nm	5,180	5,180	5,510	5,518	6,010	6,010
Engine classifiable		-	-	✓	✓	-	-
Rated speed	rpm	2,300	2,300	2,300	2,300	2,300	2,300
Fuel consumption	l/h	301	307	319	325	355	351
Bore/Stroke	mm	128/157	128/157	128/157	128/157	128/157	128/157
Displacement	l	24.24	24.24	24.24	24.24	24.24	24.24
Length of engine from front end to edge of flywheel housing	mm	1,630	1,630	1,658	1,658	1,658	1,658
Width	mm	1,153	1,153	1,153	1,153	1,153	1,153
Height	mm	1,230	1,230	1,272	1,272	1,272	1,272
Dry weight	kg	2,270	2,270	2,420	2,420	2,420	2,420
Exhaust gas aftertreatment		-	✓	-	✓	-	✓
Exhaust gas status		<b>B</b>	<b>D</b>	<b>F</b>	<b>D</b>	<b>B</b>	<b>D</b>

**B** IMO Tier II, EPA Tier 3 for private use only, China 2 for private use only, RCD 2013/53/EC

**D** IMO Tier III, EPA Tier 3 for private use only  
**F** IMO Tier II, EPA Tier 3 for private use only, China 2, RCD 2013/53/EC

Characteristics		V12				V12X	
		1900	1900 SCR	2000	2000 SCR	2000	2200
Type designation							
Arrangement and number of cylinders		V12	V12	V12	V12	V12	V12
Nominal rating	hp	1,900	1,900	2,000	2,000	2,000	2,200
Maximum torque	Nm	6,130	6,185	6,460	6,508	6,589	7,358
Engine classifiable		-	-	-	-	✓	-
Rated speed	rpm	2,300	2,300	2,300	2,300	2,300	2,300
Fuel consumption	l/h	373	374	399	396	370	412
Bore/Stroke	mm	128/157	128/157	128/157	128/157	138/165	138/165
Displacement	l	24.24	24.24	24.24	24.24	29.62	29.62
Length of engine from front end to edge of flywheel housing	mm	1,658	1,658	1,658	1,658	1,792	1,792
Width	mm	1,153	1,153	1,153	1,153	1,157	1,157
Height	mm	1,272	1,272	1,272	1,272	1,328	1,328
Dry weight	kg	2,420	2,420	2,420	2,420	2,700	2,700
Exhaust gas aftertreatment		-	✓	-	✓	-	-
Exhaust gas status		B	D	B	D	G	G

**B** IMO Tier II, EPA Tier 3 for private use only, China 2 for private use only, RCD 2013/53/EC

**D** IMO Tier III, EPA Tier 3 for private use only  
**G** IMO Tier II, EPA Tier 3 for private use only



## **Seapower**

Sole authorised importer and distributor in the ANZ region.

Ph: +61 (0) 8 9335 9777

E: [man@seapower.com.au](mailto:man@seapower.com.au)

W: [www.mandiesel.com.au](http://www.mandiesel.com.au) [www.seapower.com.au](http://www.seapower.com.au)



## **MAN Truck & Bus SE**

Vogelweiherstrasse 33

90441 Nuremberg, Germany

[www.man-engines.com](http://www.man-engines.com)

D114.660 · wd08252 · Status 08/2025 · Subject to change without notice. Modifications and errors reserved. Products may vary in their shape, construction, colour shades and included features after the copy deadline for this brochure. The illustrations may also show special equipment, decoration elements or accessories that are not standard equipment. Where symbols or numbers are used to describe an order or the subject of an order, no rights may be derived solely from these. This publication is for international use. Any statements regarding statutory, legal and tax provisions and their effects are only valid for the Federal Republic of Germany at the time this publication was last updated. Please contact your MAN sales representative for any questions concerning the regulation applicable in other countries and its legal consequences.