

ENGINEERING
TOMORROW

Danfoss

Commercial Product Selection Guide

Danfoss Limited
Amphill Road
Bedford
MK42 9ER

E: ukheating@danfoss.com
W: www.heating.danfoss.co.uk

Reception

Tel: 01234 364621
Fax: 01234 219705

UK Sales

Tel: 01234 320257
Fax: 01234 320297

Customer Service

Tel: 01234 320176
Fax: 01234 320297

Training

Tel: 01234 320131

Literature

Tel: 01234 320131

Technical Support

Tel: 01234 320256
Fax: 01234 320297

Republic of Ireland

Reception

Tel: 1800 930 242

Sales

Tel: 1800 930 243
Fax: 1800 556 691

Technical Support

Tel: 1800 930 244



Contents

Thermostatic Radiator Valves	5-23	Hydronic Balancing and Control	57-89
Working Principle of a TRV.....	6	Why Use Balancing Valves.....	58
Single Pipe and Two Pipe Systems.....	7	Balancing Valve Selection Guide - Heating Systems.....	60
Commercial Radiator Thermostat Selection Guide.....	8	Balancing Valve Selection Guide - Cooling Systems.....	62
Working Principle of a Dynamic Valve - RA-DV.....	10	MSV-O Fixed Orifice Commissioning Valve.....	64
RA-DV Selection Guide.....	11	MSV-BD Variable Orifice Commissioning Valve.....	65
Pressure Independent TRV - RA-DV for 2-Pipe Systems.....	12	MSV-F2 Variable Orifice Commissioning Valve.....	66
Fixed Capacity Valve Bodies - RA-FN Valves for 2-Pipe Systems.....	13	Differential Pressure Control Valves.....	67
Pre-setting Valve Bodies - RA-N Valves for 2-Pipe Systems.....	14	ASV-PV Differential Pressure Control Valve.....	68
Valves for 1-Pipe System - RA-G.....	15	AVPL Differential Pressure Controllers.....	69
Combi Packs RA2000.....	16	AVP Self-Acting Differential Pressure Control Valves.....	70
Built-in Sensors - Standard and Tamperproof - RA2000.....	17	AFP Self-Acting Differential Pressure Controller.....	71
Remote Sensors and Adjusters - RA2000.....	18	AB-QM Sizing Chart.....	72
Proportional Controller for Heating Circuits - FEV-IF and FEV-FF.....	19	AB-QM Pressure Independent Balancing and Control Valve.....	73
Lockshield Valves with Drain Off - RLV.....	20	AB-QM Actuator Selection Chart.....	74
Lockshield Valves without Drain Off - RLV-S.....	21	NovoCon®.....	76
Spares and Accessories - Gland Seals, Sensors and Adapters.....	22	AB-QM Actuators - TWA-Z and ABNM.....	78
Compression Fittings for Copper, PEX and ALUPEX Pipe.....	23	AME/AMV 110/120NL, AME 110NLX, AMI 140 Actuators.....	79
Motorised Control Valves	25-55	FEV-Z Climate Sensor.....	80
Special Functions of iMCV Electrical Actuators.....	26	AB-PM Combined Automatic Balancing Valve.....	81
Valve Sizing.....	27	AME 55/85/435 QM Actuators.....	82
Overview - Control Valves.....	28	Differential By-Pass Valves.....	83
Overview - Zone and Rotary Valves.....	29	AVDO Automatic By-Pass Valve.....	84
Overview - Electrical Actuators.....	30	AVDA By-Pass Valves.....	85
Combination Guide - Motorised Control Valves.....	31	AVPA Self-Acting Differential Pressure Relief Controller.....	86
VZL2 and VZL4 (2 and 4-Way Valves).....	32	AFPA Pressure Actuator.....	87
AME 130(H)/140(H) Electric Actuators.....	33	MTCV Thermostat Circulation Valve.....	88
AMV 130(H)/140(H) Electric Actuators.....	34	PFM100 Measuring Equipment.....	89
TWA-ZL Thermal Actuator.....	35	Ultrasonic Energy Meters and Calculators	91-93
VRB2 (2-Port Seated Valves).....	36	Ultrasonic Energy Meter - Sonometer.....	92
VRB3 (3-Port Seated Valves).....	37	Energy Meter Sizing Chart.....	93
VF2 and VF3 (2 and 3-Port Seated Valves).....	38	Butterfly and Check Valves	95-101
AME 435 - Actuator for Modulating Control.....	39	VFY-LG.....	96
AMV 435 - Actuator for 3-Point Control.....	40	VFY-WH.....	97
AME 438 SU Spring Return - Actuator for Modulating Control.....	41	VFY-LH.....	98
AMV 438 SU Spring Return - Actuator for 3-Point Control.....	42	NVD 402 and NVD 462.....	99
AME 55 and AME 56 - Actuators for Modulating Control.....	43	NVD 802, NVD 805 and NVD 895.....	100
AMV 55 and AMV 56 - Actuators for 3-Point Control.....	44	NVD 812.....	101
AME 85 and AME 86 - Actuators for Modulating Control.....	45	Plate Exchangers	103-109
AMV 85 and AMV 86 - Actuators for 3-Point Control.....	46	Brazed Micro Plate™ Heat Exchangers.....	104
AMV 855 - Actuators for 3-Point Control.....	47	Gasketed Micro Plate™ Heat Exchangers.....	105
VFM2 - 2-Way Seated Control Valve.....	48	Selection Chart - Heating Applications.....	106
AMV 655 and AMV 658 - Actuators for 3-Point Control.....	49	Selection Chart - Cooling and DHW Applications.....	107
AME 655 and AME 658 - Actuators for Modulating Control.....	49	XB Range.....	108
HRB3 and HRB4 Brass Rotary Valves.....	50	Hexact Calculation Software.....	109
HRE3 and HRE4 Cast Iron Rotary Valves.....	51		
AMB 162 and AMB 182 Rotary Actuators.....	52		
AMZ 112, 113 and 122 Motorised Zone Valves.....	53		
VFY-WA Butterfly Valves.....	54		
AMD - Electrical Actuators for Air Dampers.....	55		



Thermostatic Radiator Valves

Danfoss are world leaders in the design and manufacture of radiator thermostats. Having invented the concept in 1943 Danfoss have, in the ensuing years, gone on to develop and manufacture numerous generations of radiator thermostats, offering ever improved performance.

The knowledge and experience of radiator thermostats possessed by Danfoss is unsurpassed, bringing together more than half a century of design, manufacturing and application knowledge that is second to none.

The rapid growth in the sale of radiator thermostats has, to a large extent, been down to the simplicity of the products, in terms of application and ease of use. Generally the more sophisticated the design, the more energy efficient and reliable the product is and Danfoss are at the top of the list when it comes to energy efficiency and reliability.

The need for high performance is never greater than in the demanding commercial heating market. In addition to expectations of high performance, specifiers and building owners also expect products which can withstand inevitable heavy handling and, in some cases misuse, plus be long lasting into the bargain.

The Danfoss RA2000 range is based on a saturated vapour sensor to provide the ultimate in control performance. The reason for this much improved performance is the well defined sensor location, and the small mass of the gas charge (saturated vapour) compared to other types (e.g. liquid or wax).

Contents

- Working Principle of a TRV6
- Single Pipe and Two Pipe Systems7
- Commercial Radiator Thermostat Selection Guide.....8
- Working Principle of a Dynamic Valve - RA-DV 10
- RA-DV Selection Guide 11
- Pressure Independent Thermostatic Radiator Valve - RA-DV 12
- Fixed Capacity Valve Bodies - RA-FN Valves for 2-Pipe Systems 13
- Pre-setting Valve Bodies - RA-N Valves for 2-Pipe Systems 14
- Valves for 1-Pipe System - RA-G..... 15
- Combi Packs RA2000..... 16
- Built-in Sensors - Standard and Tamperproof - RA2000..... 17
- Remote Sensors and Adjusters - RA2000 18
- Proportional Controller for Heating Circuits - FEV-IF and FEV-FF ... 19
- Lockshield Valves with Drain Off - RLV.....20
- Lockshield Valves without Drain Off - RLV-S 21
- Spares and Accessories - Gland Seals, Sensors and Adapters..... 22
- Compression Fittings for Copper, PEX and ALUPEX Pipe 23



Working Principle

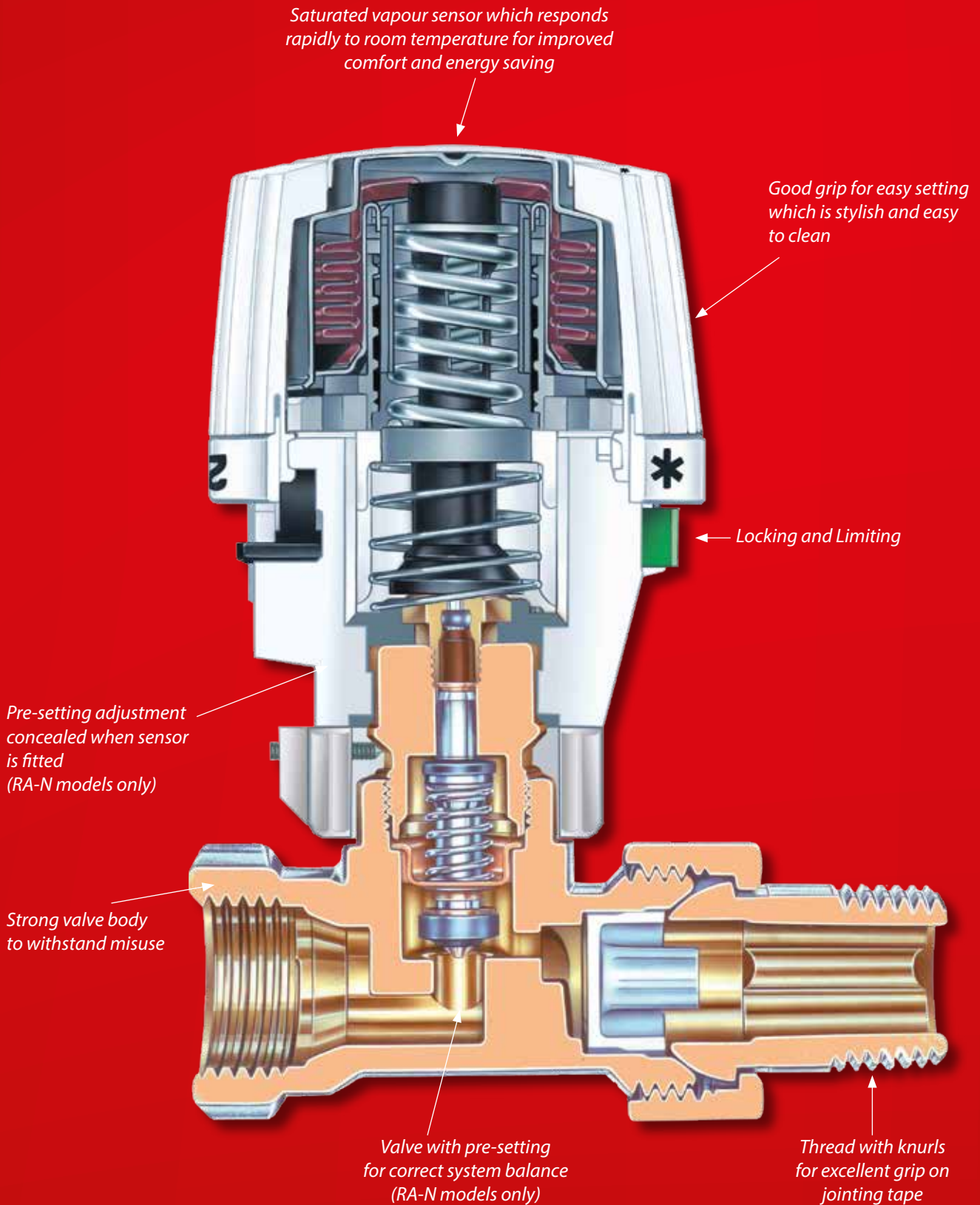

Single Pipe and Two Pipe Systems

There are two main types of radiator system, each with unique operating properties and each requiring a different valve type selection. See below for a quick guide to single and two pipe heating systems:

Single Pipe System

As the name implies, a single pipe system is a collection of radiators all connected to a single loop of pipe work throughout the building. Each radiator has the flow and return connected to the same pipe. Natural convection allowing heated water to rise into the radiator, displacing cooler water back into the single pipe circuit.

Single pipe systems can suffer from certain system specific problems:

- Because each radiator in the circuit extracts heat from the heated water, as you get further down the circuit the flow temperature is reduced requiring larger radiators to be fitted towards the end of the circuit.
- Larger pipe size required to feed the radiators.
- It is difficult to compensate for undersized radiators by increasing the water flow.

Single pipe systems are rarely fitted from new today, however many systems are still in operation and can be found in many industrial buildings, factories and schools. Designed for single pipe heating systems, the RA-G single pipe thermostatic valves have large diameter valve cones which deliver high capacity flow and control.

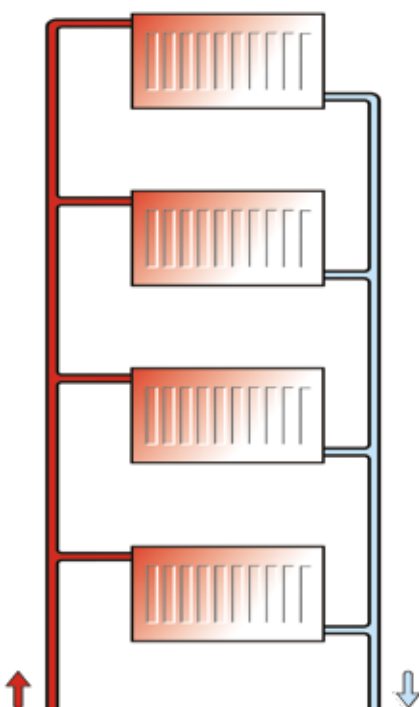
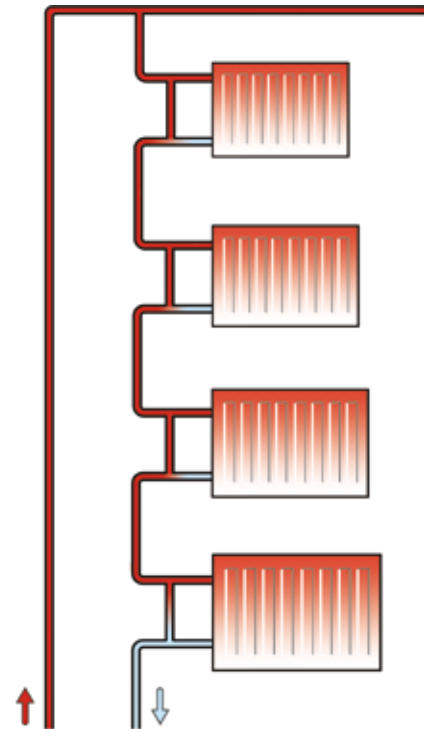

Two Pipe System

In the two pipe system there are separate flow and return pipes, with some form of bypass (preferably automatic) between the flow and the return. Because the flow and return in these systems is separate, the temperature of the water reaching each radiator is basically the same meaning radiator output is roughly the same at each branch of the circuit.

- Two pipe systems benefit from lower material costs due to pipe work and radiator surface area being smaller generally than in a one pipe system.
- Same size radiators can be used throughout the system.
- System balance is important to reduce noise and temperature variations in the system.

Two pipe systems can be fitted with pre-setting (RA-N) or fixed capacity (RA-FN) valves and RA-DV together with a thermostatic sensor from the RA2000 range.

Commercial Radiator Thermostat Selection Guide

Key

★	Approved combination Refer to notes for any restrictions/advice
1	Mount sensor horizontally
2	Consider use of remote sensor to improve performance
3	Remote sensor is recommended
4	Valve body flow selector must be commissioned

Description

Model

Codes

Temperature Range

Valve Options

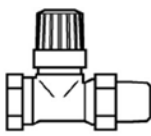
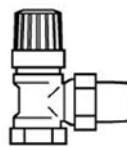
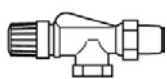
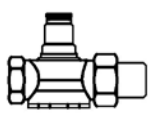
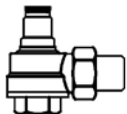
		Size	Dynamic Valves		Standard Valves		Valves with pre-setting		
			Type	Code	Type	Code No.	Type	Code No.	
2-Pipe System	Straight		8/10mm	-	-	RA-FS 15	013G628300	-	-
			15mm	-	-	RA-FS 15	013G628100	-	-
			½"	RA-DV 15	013G772400	RA-FN 15	013G002400	RA-N 15	013G003400
			½" / 15mm	-	-	RA-FN 15	013G008400	RA-N 15	013G0034AA
			¾"	-	-	RA-FN 20	013G002600	RA-N 20	013G003600
			1"	-	-	RA-FN 25	013G002800	RA-N 25	013G003800
			¾"	RA-DV 10	013G772200	RA-FN 10	013G002200	RA-N 10	013G003200
	Vertical Angle		½"	RA-DV 15	013G772300	RA-FN 15	013G002300	RA-N 15	013G003300
			½" / 15mm	-	-	RA-FN 15	013G0023AA	RA-N 15	013G0033AA
			¾"	-	-	RA-FN 20	013G002500	RA-N 20	013G003500
			1"	-	-	RA-FN 25	013G002700	RA-N 25	013G003700
			¾"	RA-DV 10	013G772100	RA-FN 10	013G002100	RA-N 10	013G003100
	Horizontal Angle		½" / 15mm	-	-	RA-FN 15	013G014900	RA-N 15	013G0153AA
			¾"	-	-	RA-FN 20	013G014500	RA-N 20	013G015500
			¾"	-	-	RA-FN 10	013G014100	RA-N 10	013G015100
1-Pipe System	Straight		½"	-	-	RA-G 15	013G167500	-	-
			¾"	-	-	RA-G 20	013G167700	-	-
			1"	-	-	RA-G 25	013G167900	-	-
	Vertical Angle		½"	-	-	RA-G 15	013G167600	-	-
			¾"	-	-	RA-G 20	013G167800	-	-
			1"	-	-	RA-G 25	013G168000	-	-

	Built-in Sensors			Remote Sensors (0-2m)			2/5/8m Wall Adjusters
	Standard	Low Temp.	Tamperproof	Standard	Low Temp.	Tamperproof	
							
	RA2910	RA2914	RA2920	RA2912	RA2916	RA2922	RA5062 RA5065 RA5068 RA5075
	013G291000	013G291400	013G292000	013G291200	013G291600	013G292200	013G506200 013G506500 013G506800 013G507500
	5-26°C	5-22°C	5-26°C	5-26°C	5-22°C	5-26°C	6-28°C
	Sensor Options						
	4 ★	4 ★	4 ★	4 ★	4 ★	4 ★	4 ★
	1 ★	1 ★	1 ★	★	★	★	★
	2 ★	3 ★	2 ★	★	★	★	★
	★	★	★	★	★	★	★
	1 ★	1 ★	1 ★	★	★	★	★
	2 ★	3 ★	2 ★	★	★	★	★

Working Principle RA-DV

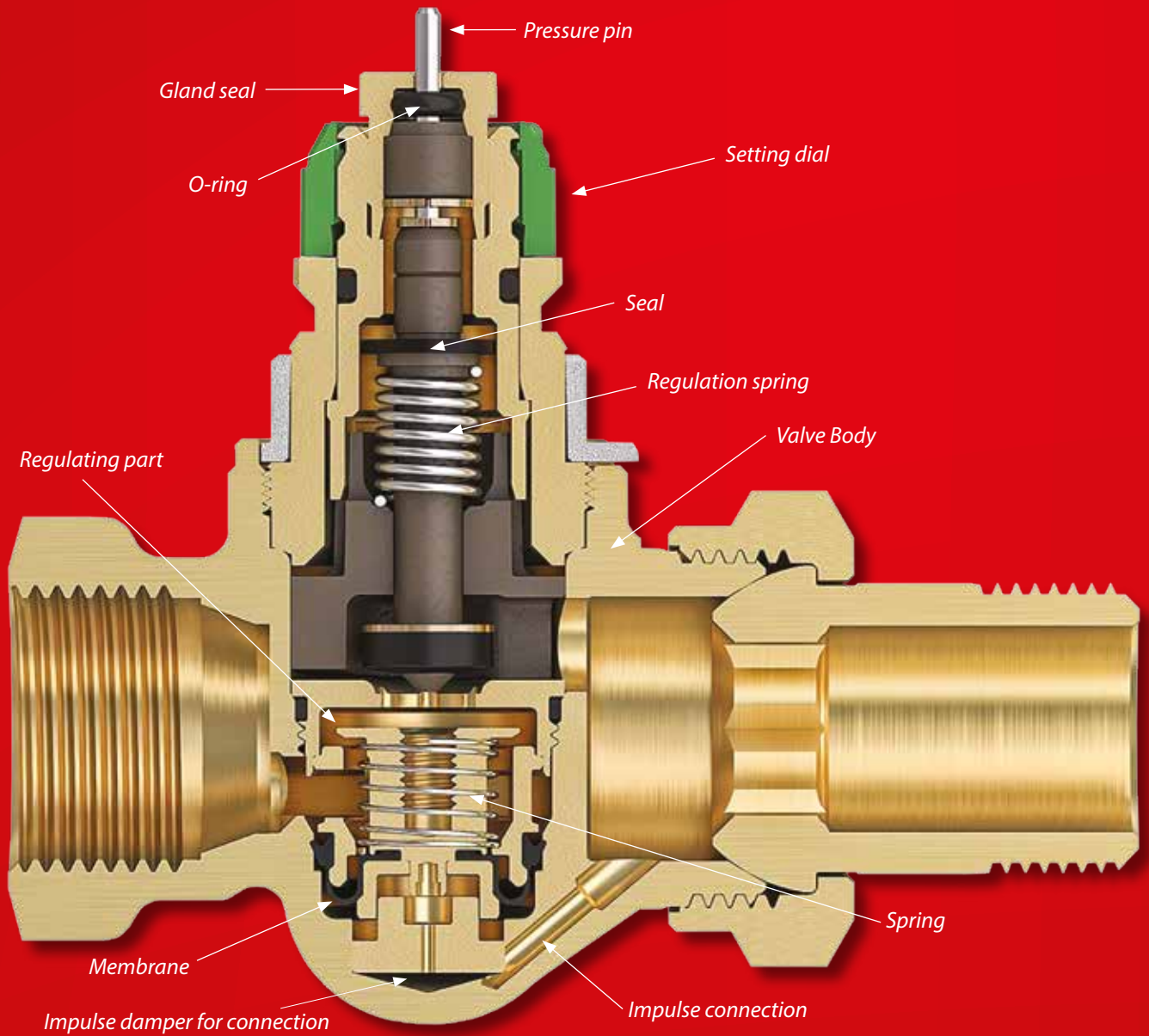

Selection Guide RA-DV

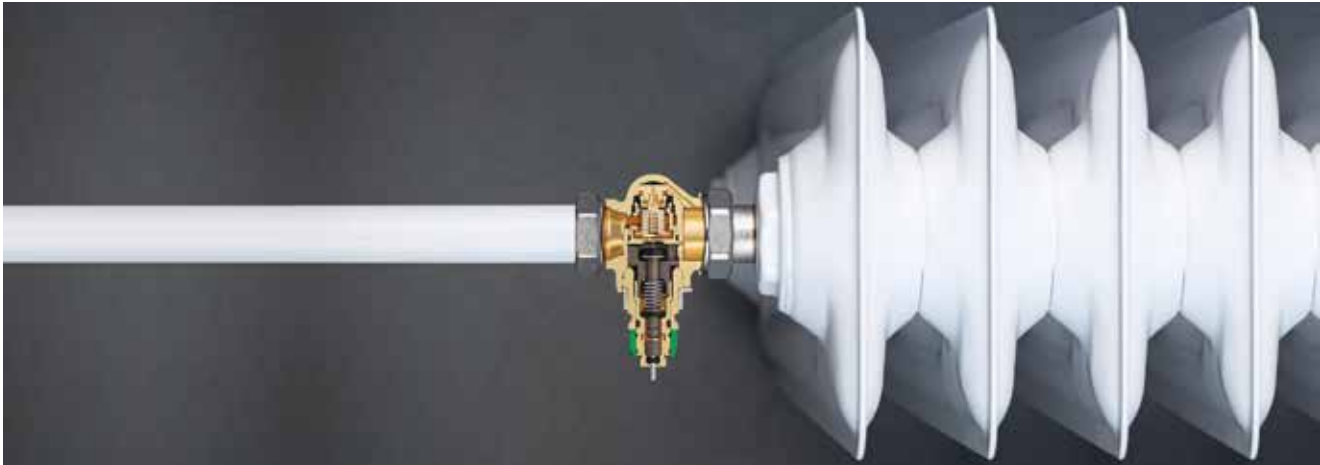
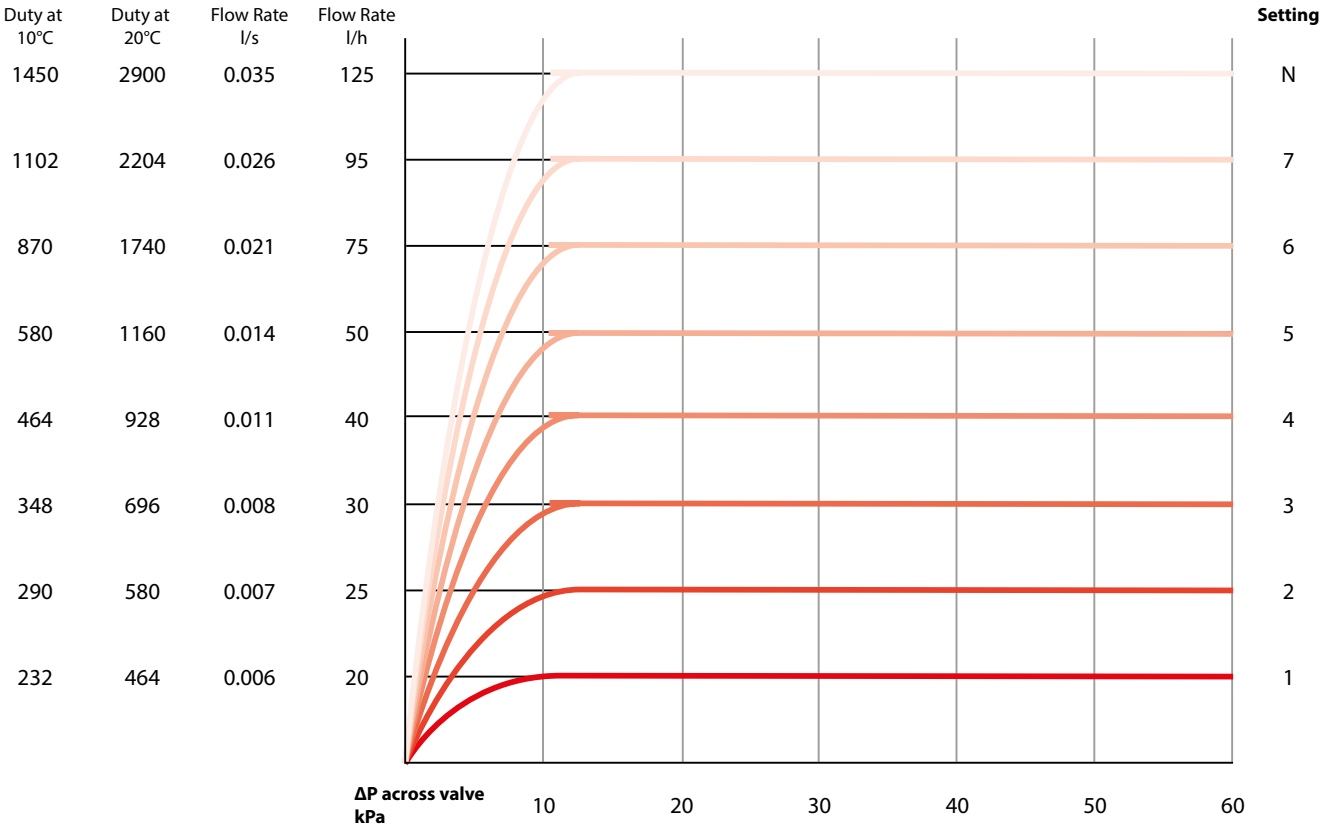

Pressure Independent Thermostatic Radiator Valve **RA-DV**



- Fast consistent and comfortable heating
- Reduced system noise
- Reduced costs

Automatic balancing provides instant benefits under full and partial load conditions. It is quick and easy to achieve and is a one-off investment with a fast payback time.

Eliminating pressure fluctuations is the key to both successful balancing and removing the source of user complaints about over or under-heating, noise and excessive energy costs.

At the same time, the temperature control will benefit from the optimised system conditions, making room temperature more stable and precise.

RA-DV valves are suitable for use with all RA2000 sensors and may also be used with RAS-D² and RAS-C² sensors. Please refer to our technical department for capacity information if using RAS-D² or RAS-C² sensors.

Please refer to page 23 for fittings.

Description	Model	Version	Connection	Flow (l/h)*	Code Number
RA-DV 10	Angle	DIN	3/8"	25-125	013G772100
RA-DV 10	Straight	DIN	3/8"	25-125	013G772200
RA-DV 15	Angle	DIN	1/2"	25-125	013G772300
RA-DV 15	Straight	DIN	1/2"	25-125	013G772400

* 20-125 l/h including a gas filled RA2000 sensor

Description	Code Number
Pre-setting tool For easy pre-setting of a Dynamic Valve	013G783000

Description	Code Number
ΔP tool For simple verification of sufficient differential pressure and pump optimisation	013G785500

Solutions	Pressure	Radiator	System	Economy
<p>Radiator fitted with RA-DV</p>	<p>Max. differential pressure = 60 kPa</p>	<p>Max. flow = 125 l/h P = 3140 W at ΔT = 20K P = 4700 W at ΔT = 30K</p>	<ul style="list-style-type: none"> • Best choice for complex riser designs • Best choice when main risers/return pipes are difficult to access • Best choice when main riser/return pipes are distant from each other 	<p>Best choice for risers with few radiators</p>

Fixed Capacity Valve Bodies RA-FN Valves for 2-Pipe Systems



Pattern	Type	Code No	Connections		Kv Value $X_p = 2K^{(2)}$
			Pipe	Radiator Tail	
Straight	RA-FN 10	013G002200	3/8" BSP	3/8" BSP	0.56
	RA-FN 15	013G002400	1/2" BSP	1/2" BSP	0.73
	RA-FN 15	013G008400	15mm or 1/2" BSP	1/2" BSP	0.73
	RA-FN 20	013G002600	3/4" BSP	3/4" BSP	1.04
	RA-FN 25	013G002800	1" BSP	1" BSP	1.04
Vertical Angle ⁽¹⁾	RA-FN 10	013G002100	3/8" BSP	3/8" BSP	0.56
	RA-FN 15	013G002300	1/2" BSP	1/2" BSP	0.73
	RA-FN 15	013G0023AA	15mm or 1/2" BSP	1/2" BSP	0.73
	RA-FN 20	013G002500	3/4" BSP	3/4" BSP	1.04
Horizontal Angle	RA-FN 25	013G002700	1" BSP	1" BSP	1.04
	RA-FN 10	013G014100	3/8" BSP	3/8" BSP	0.56
	RA-FN 15 UK	013G014900	15mm or 1/2" BSP	1/2" BSP	0.73
	RA-FN 20	013G014500	3/4" BSP	3/4" BSP	0.80

(1) To ensure optimum performance use remote sensor

(2) Kv values when used with RA2000 sensors

Technical Specifications

Maximum Operating Temperature	120°C
Maximum Working Pressure	10 Bar
Maximum Differential Pressure	0.6 Bar

- RA-FN valves without pre-setting
- RA-FN valves are easily recognised by a grey cover cap
- May also be used with RAS-D² and RAS-C² sensors (RA-FN only)
- Wide range of fittings (see page 23)

RA-FN valves are designed for use in 2-pipe heating systems where circulation through both pipe work and radiator is pumped. They are conventional uni-directional valves without pre-setting; system balancing must be made using lockshield valves installed on the radiator return connection. Please refer to pages 20 and 21 for matching lockshield valves.

A wide range of compression fittings for copper, PEX and ALUPEX pipe are available for use with RA-FN valves, see page 23.

All valves incorporate a gland-seal assembly that can be replaced without the need for special tools and without draining down the system.

RA-FN valves are suitable for use with all RA2000 sensors and may also be used with RAS-D² and RAS-C² sensors. Please refer to our technical department for capacity information if using RAS-D² or RAS-C² sensors.

Pattern	Type	D d ₂ BSP		L ₁	L ₂	L ₃	L ₄	L ₅	L ₆	L ₇ *	L ₈	L ₉	L ₁₀	L ₁₁	Arc. Flats		
		S ₁	S ₂														
Straight	RA-FN 10	3/8"	3/8"	60	85				47	96						22	27
	RA-FN 15	1/2"	1/2"	67	95				47	96						27	30
	RA-FN 20	3/4"	3/4"	74	106				52	101						32	37
	RA-FN 25	1"	1"	90	126				52	101						41	46
Vertical Angle	RA-FN 10	3/8"	3/8"			27	52	22	47	96						22	27
	RA-FN 15	1/2"	1/2"			30	58	26	47	96						27	30
	RA-FN 20	3/4"	3/4"			34	66	29	52	101						32	37
	RA-FN 25	1"	1"			40	75	34	52	101						41	46
Horizontal Angle	RA-FN 10	3/8"	3/8"						59	108	26	51	22			22	27
	RA-FN 15 UK	1/2"	1/2"						60	98	26	54	33	44		27	30
	RA-FN 20	3/4"	3/4"						61	110	34	66	30			32	27

* Add 32mm to L₇, to allow for sensor removal.

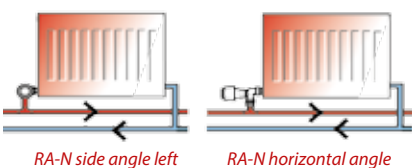

Straight
RA-N or RA-FN

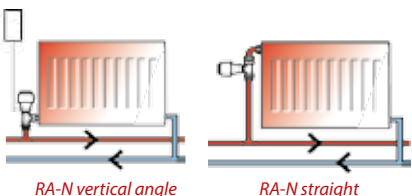

Horizontal Angle
RA-N 10, 15, 20 &
RA-FN 10 or 20

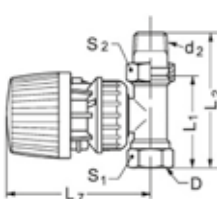

Vertical Angle
RA-N
or RA-FN

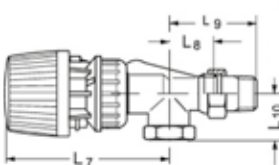
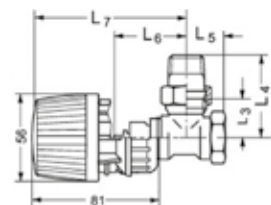

Horizontal Angle
RA-FN 15 UK

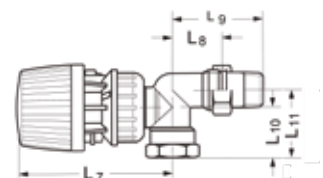

Pre-Setting Valve Bodies

RA-N Valves for 2-Pipe Systems



- RA-N valves with pre-setting for larger heating systems
- RA-N valves in flow
- RA-N valves are easily recognised by a red cover cap
- Available in vertical angle, horizontal angle, side angle and straight pattern versions in 3/8", 1/2", and 1" sizes

RA-N are uni-directional valves with integrated pre-setting. Pre-setting allows the commissioning engineer to precisely set the flow rate through the valve by adjusting the valve capacity to match the radiator heat output requirement. Pre-setting is carried out by setting a calibrated orifice within the valve. The setting is achieved by turning a scale located in the top part of the valve body. The setting mechanism is concealed once the thermostat sensor is fitted. This type of pre-setting is significantly more accurate than that possible with conventional lockshield valves. When pre-setting valves are used the role of the lockshield valve is simply to provide isolation for radiator removal.

$\Delta p = 10 \text{ kPa}$

RA-N 10 Guideline basis RA2000 sensor					RA-N 15 Guideline basis RA2000 sensor				
$\Delta T(K)$					$\Delta T(K)$				
10K	15K	20K		10K	15K	20K			
~Watt					~Watt				
100	200	250	1	100	200	250	1		
250	400	550	2	250	400	550	2		
400	650	850	3	400	650	850	3		
650	1000	1350	4	700	1100	1450	4		
900	1350	1800	5	1100	1650	2150	5		
1200	1800	2400	6	11450	2150	2900	6		
1350	2050	2750	7	1850	2800	3700	7		
2050	3050	4100	N	2650	4000	5350	N		

RA-N 20 Guideline basis RA2000 sensor					RA-N 20 UK Guideline basis RA2000 sensor				
$\Delta T(K)$					$\Delta T(K)$				
10K	15K	20K		10K	15K	20K			
~Watt					~Watt				
350	550	700	1	550	850	1150	1		
550	800	1100	2	700	1100	1450	2		
600	900	1200	3	900	1350	1800	3		
950	1400	1900	4	1250	1900	2550	4		
1250	1900	2550	5	1700	2550	3400	5		
1650	2500	3350	6	2150	3250	4350	6		
2650	4000	5350	7	2650	4000	5350	7		
3800	5700	7600	N	2900	4350	5850	N		

Pattern	Type	Code No	Connections		Kv Value ⁽¹⁾⁽³⁾ Xp = 2K	
			Pipe	Radiator Tail	Min	Max
Straight	RA-N 10	013G003200	3/8" BSP	3/8" BSP	0.04	0.56
	RA-N 15	013G003400	1/2" BSP	1/2" BSP	0.04	0.73
	RA-N 15	013G0034AA	15mm or 1/2" BSP	1/2" BSP	0.04	0.73
	RA-N 20	013G003600	3/4" BSP	3/4" BSP	0.10	1.04
	RA-N 25	013G003800	1" BSP	1" BSP	0.10	1.04
Vertical Angle ⁽²⁾	RA-N 10	013G003100	3/8" BSP	3/8" BSP	0.04	0.56
	RA-N 15	013G003300	1/2" BSP	1/2" BSP	0.04	0.73
	RA-N 15	013G0033AA	15mm or 1/2" BSP	1/2" BSP	0.04	0.73
	RA-N 20	013G003500	3/4" BSP	3/4" BSP	0.10	1.04
Horizontal Angle	RA-N 25	013G003700	1" BSP	1" BSP	0.10	1.04
	RA-N 10	013G015100	3/8" BSP	3/8" BSP	0.04	0.56
	RA-N 15	013G015300	1/2" BSP	1/2" BSP	0.04	0.73
Side Angle ⁽⁴⁾	RA-N 15	013G0153AA	15mm or 1/2" BSP	1/2" BSP	0.04	0.73
	RA-N 20	013G015500	3/4" BSP	3/4" BSP	0.16	0.80
	RA-N 10L	013G023100	3/8" BSP	3/8" BSP	0.04	0.56
	RA-N 10R	013G023200	3/8" BSP	3/8" BSP	0.04	0.56
	RA-N 15L	013G233000	1/2" BSP	1/2" BSP	0.04	0.73
	RA-N 15R	013G023400	1/2" BSP	1/2" BSP	0.04	0.73

(1) Kv value at Xp = 2 when used with RA2000 sensors. (2) To ensure optimum performance use remote sensor.
 (3) Refer to setting table supplied with valves to adjust Kv. (4) L = Left, R = Right

Technical Specifications

Maximum Operating Temperature	120°C
Maximum Working Pressure	10 Bar
Maximum Differential Pressure	0.6 Bar

Pattern	Type	D d ₂ BSP	L ₁	L ₂	L ₃	L ₄	L ₅	L ₆	L ₇ * 	L ₈	L ₉	L ₁₀	Arc. Flats	
													S ₁	S ₂
Straight	RA-N 10	3/8" 3/8"	60	85				47	96				22	27
	RA-N 15	1/2" 1/2"	67	95				47	96				27	30
	RA-N 20	3/4" 3/4"	74	106				52	101				32	37
	RA-N 25	1" 1"	90	126				52	101				41	46
Vertical Angle	RA-N 10	3/8" 3/8"			27	52	22	47	96				22	27
	RA-N 15	1/2" 1/2"			30	58	26	47	96				27	30
	RA-N 20	3/4" 3/4"			34	66	29	52	101				32	37
	RA-N 25	1" 1"			40	75	34	52	101				41	46
Horizontal Angle	RA-N 10	3/8" 3/8"						59	108	26	51	22	22	27
	RA-N 15	1/2" 1/2"						60	109	26	55	27	27	30
	RA-N 20	3/4" 3/4"						61	110	34	66	30	32	27
Side Angle	RA-N 10	3/8" 3/8"						47	103	27	52	27	22	27
	RA-N 15	1/2" 1/2"						47	96	30	58	33	27	30

* Add 32mm to L₇, to allow for sensor removal.

Valves for 1-Pipe Systems

RA-G

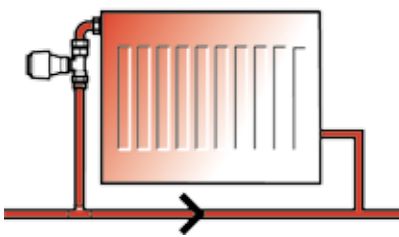
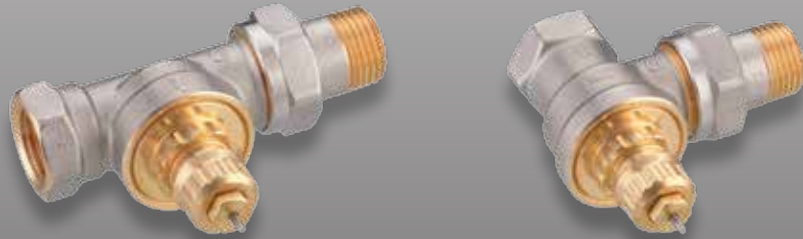

RA-G straight

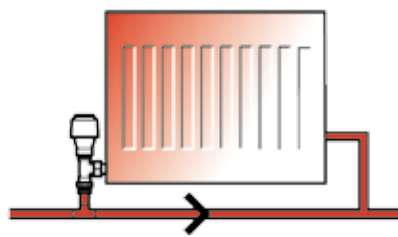

RA-G vertical angle

- RA-G valves in flow
- Suitable for use with all RA2000 sensors
- Available in both vertical angle and straight pattern designs in 1/2", 3/4" and 1" sizes

RA-G valves are high capacity low resistance valves for use in conventional 1-pipe heating systems in which water circulation through the radiator is mainly by thermo-siphon. In such systems the circulating pressure available to overcome the frictional resistance of the valve and the radiator is extremely low and is generally insufficient to overcome the resistance of normal 2-pipe radiator thermostats.

RA-G valves are specifically designed for use in such systems and have large diameter valve cones which deliver high capacities at low proportional offsets ensuring that comfort temperatures can be maintained under all load conditions.

All valves incorporate a gland-seal assembly that can be replaced without the need for special tools and without draining down the system.

Pattern	Type	Code No	Connections		Kv Value $X\rho = 2K^{(2)}$
			Pipe ⁽³⁾	Radiator Tail	
Straight	RA-G 15	013G167500	1/2" BSP	1/2" BSP	1.63
	RA-G 20	013G167700	3/4" BSP	3/4" BSP	2.06
	RA-G 25	013G167900	1" BSP	1" BSP	2.27
Vertical Angle ⁽¹⁾	RA-G 15	013G167600	1/2" BSP	1/2" BSP	2.06
	RA-G 20	013G167800	3/4" BSP	3/4" BSP	2.20
	RA-G 25	013G168000	1" BSP	1" BSP	2.41

Please note:

(1) To ensure optimum performance use remote sensor

(2) Kv values when used with RA2000 Sensors

(3) Not suitable for use with Fittings listed on page 23

Technical Specifications

Maximum Operating Temperature	120°C
Maximum Working Pressure	10 Bar
Maximum Differential Pressure (RA-G 25)	0.16 Bar
Maximum Differential Pressure (RA-G 15 & 20)	0.2 Bar

Type	DN	D	d ₂	L ₁	L ₂	L ₃	L ₄	L ₅	L ₆	L ₇	S ₁	S ₂
RA-G 15	15	1/2"	1/2"	68	96	30	58	27	52	103	27	30
RA-G 20	20	3/4"	3/4"	74	106	34	66	30	54	103	32	37
RA-G 25	25	1"	1"	90	126	42	78	34	57	106	41	46

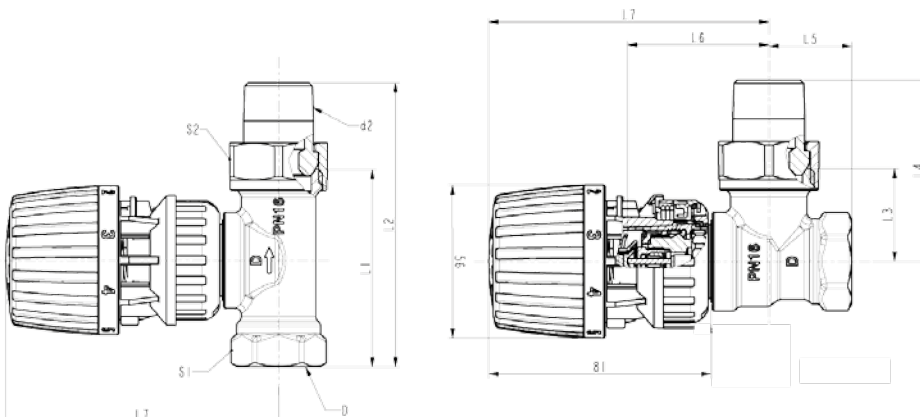

Combi Packs RA2000



- Convenient pack based solution
- Packs available with or without lockshield
- 4 unique valve combinations covering the most popular RA2000 combinations

Complementing the range of individual separates available in the RA2000 range are the RA2000 Combi Packs. The range of four packs brings together the most popular RA2000 components into a convenient package allowing for simple ordering of all components with one code number.

Packs come complete with a standard RA2910 thermostatic head and are available in either ½" (complete with 15mm compression adaptors) or ¾" variations and with or without a lockshield valve.

Application

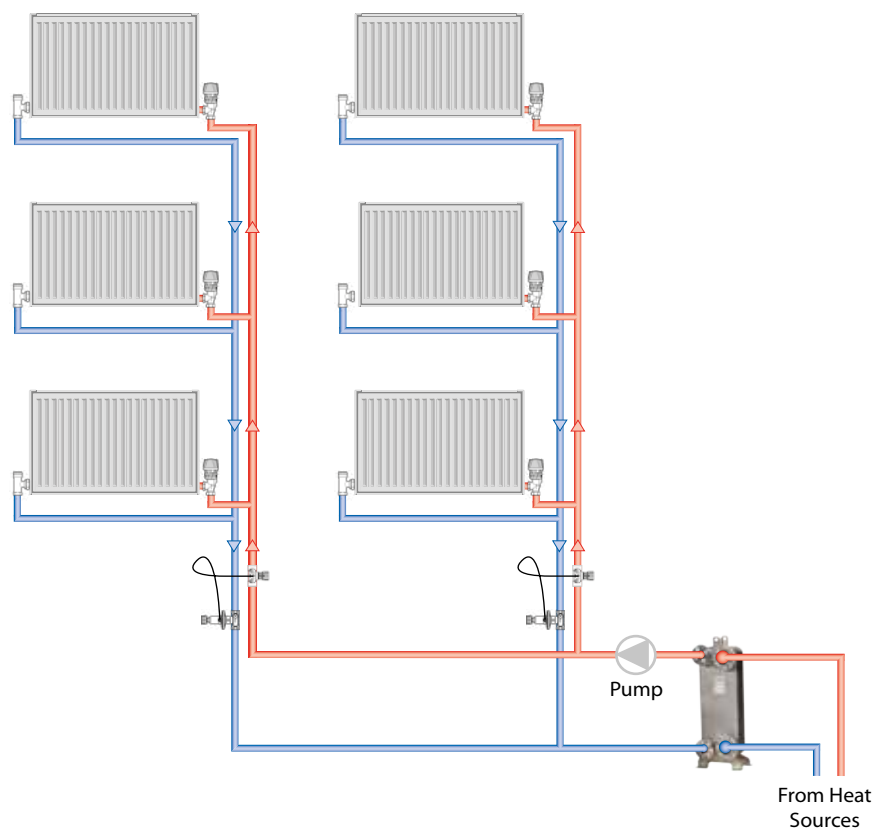

Description	Contains	Code No
Vertical Angle ½" / 15mm Combi pack	1 x RA2910 Thermostatic Head 1 x RA-FN15 Valve (inc. 15mm compression fitting)	013G602100
Vertical Angle ¾" Combi Pack	1 x RA2910 Thermostatic Head 1 x RA-FN20 Valve	013G602200
Vertical Angle + Lockshield Valve ½" / 15mm Combi Pack	1 x RA2910 Thermostatic Head 1 x RA-FN15 Valve (inc. 15mm compression fitting) 1 x RLV-S15 ½"/15mm Lockshield	013G602300
Vertical Angle + Lockshield Valve ¾" Combi Pack	1 x RA2910 Thermostatic Head 1 x RA-FN20 Valve 1 x RLV-S20 ¾" Lockshield	013G602400

Built-in Sensors RA-2000

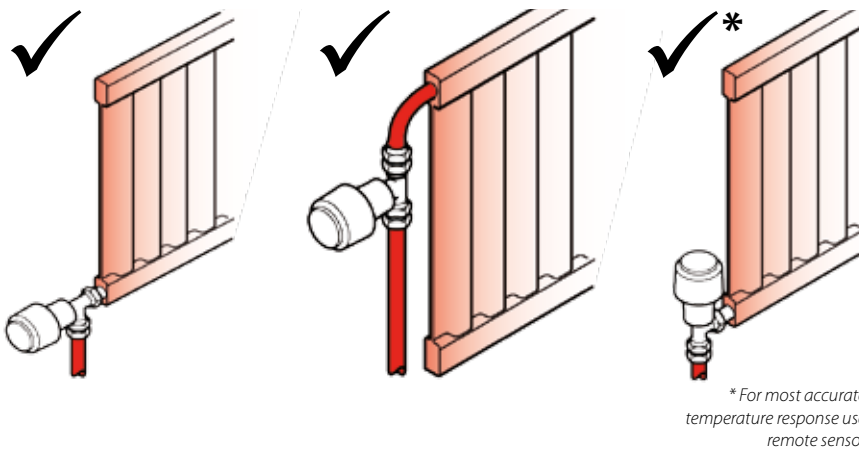

- RA2910 temperature range 5-26°C
- RA2920 tamperproof
- All models have locking and limiting feature
- Use with RA-N, RA-FN or RA-G valves

RA2000 sensors are high performance temperature sensors ideally suited for commercial applications. The temperature sensor uses frictionless bellows charged with a small volume of liquified gas.

The sensor relies upon the state change from liquid to a gas as the temperature of the liquid increases to modulate the valve towards the closed position. When the temperature falls the gas condenses back to a liquid and the spring within the sensor allows the valve to modulate open until the bellows pressure and spring pressure are equal, and the valve cone is stationary.

Type	Code No	Sensor (max. sensor temp 60°C)	Temp Range Xp = 2K
RA2910	013G291000	Built-in	5-26°C
RA2914	013G291400	Built-in, low temperature range model	5-22°C
RA2920 *	013G292000	Tamperproof	5-26°C

* Toolkit required

Locking and Limiting

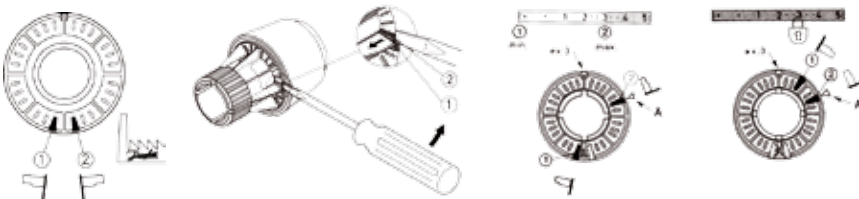

Sensor Mounting

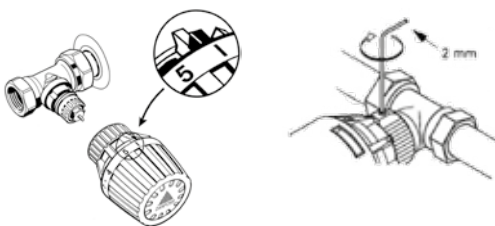

This type of saturated vapour pressure sensor has many advantages including low thermal mass giving quick reaction times and a defined sensor location at coolest part of bellows system.

This latter feature gives the product a very low flow temperature dependence making it ideal for use in systems with weather compensated flow temperatures.

The range includes standard temperature range (5-26°C) and low temperature range (5-22°C) models. Both incorporate range locking and limiting features that allow the commissioning engineer to lock or limit the setting range of the sensor.

For best performance built-in temperature sensors should be mounted horizontally. Care should be taken not to cover the thermostat or to locate it where it may be influenced by heat from electrical appliances or cold draughts.

Remote Sensors and Adjusters

RA2000



- All models have locking and limiting
- Capillary can be adjusted between 0-2 metres on remote sensors
- Remote adjusters available
- Use with RA-N, RA-FN or RA-G valves

Utilising the same sensor technology as the built-in sensor, remote sensors are ideal for use in situations where built-in sensors may be adversely affected by heat gains or cold draughts.

Remote sensors comprise a setting unit that is mounted on the valve and a remote sensor which can be located up to 2 metres from the setting unit. The two components are interconnected by an ultra-thin capillary tube. During installation, the required length of tube is pulled out and fixed to the wall with clips or by staple gun.

The range includes standard (5-26°C) and low (5-22°C) temperature range models. Both incorporate range locking and limiting features that allow the commissioning engineer to lock or limit the setting range of the sensor.

The RA2000 range also includes versions that take both sensing and temperature adjustment away from the valve. These remote temperature adjusters are ideal for use in situations where radiators are encased or where the demand is to locate the temperature adjustment at a position more convenient than on the radiator e.g. in residential accommodation for the elderly. The product is also an ideal solution for heated ceiling applications.

The remote temperature adjuster models comprise an actuator that is mounted on the valve and a thermostat unit which provides temperature sensing and adjustment. These are interconnected by an ultra-thin capillary tube. During installation the required length of capillary is pulled out and fixed to the wall using clips or staples.

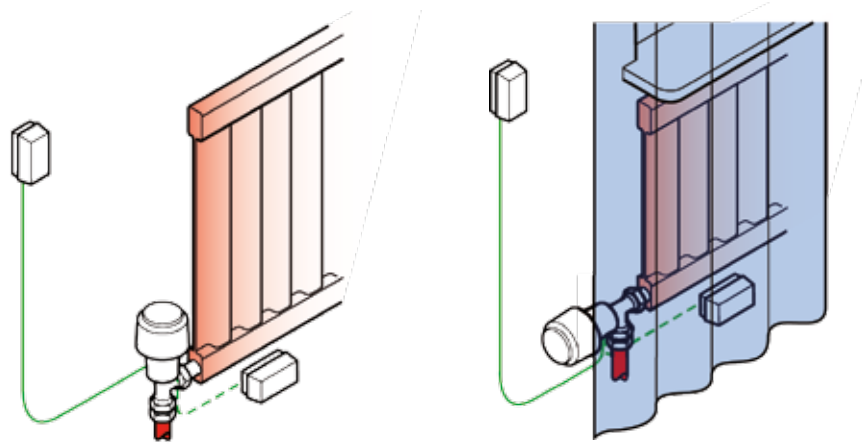

RA2000 Remote Sensors

Type	Code No	Sensor (max sensor temp 60°C)	Temp Range Xp = 2K
RA2912	013G291200	Remote Sensor, 0-2m capillary tube	5-26°C
RA2916	013G291600	Remote Sensor, 0-2m capillary tube	5-22°C

RA2000 Remote Sensor Adjusters

Type	Code No	Sensor (max sensor temp 60°C)	Temp Range Xp = 2K
RA5062	013G506200	2m Capillary includes locking and limiting	8-28°C
RA5065	013G506500	5m Capillary includes locking and limiting	8-28°C
RA5068	013G506800	8m Capillary includes locking and limiting	8-28°C
RA5075	013G507500	15m Capillary includes locking and limiting	8-28°C

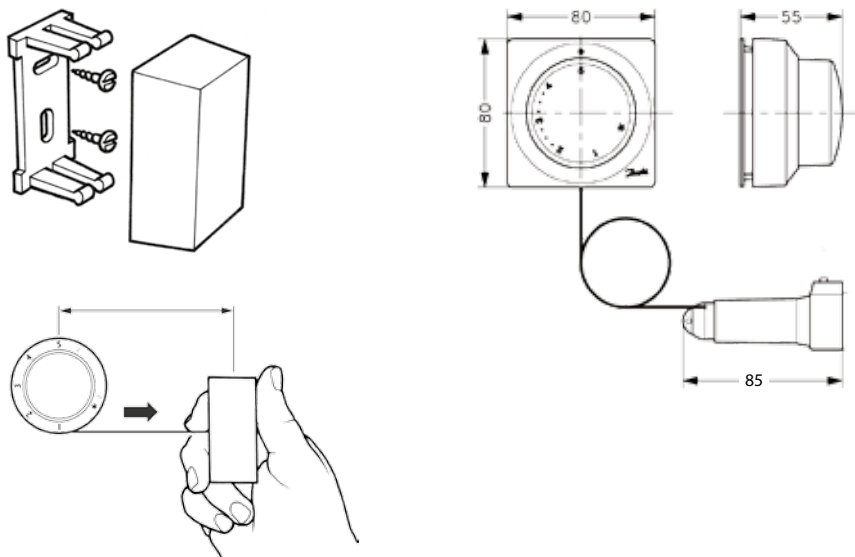

Heating Controller FEV-IF and FEV-FF



Type	Code No.	Sensor	Capillary Tube	Setting Range
FEV-IF	013G546700	Integrated Sensor	5 metres	17-27°C
FEV-FF	013G546600	Remote Sensor	2 + 2 metres	

Application

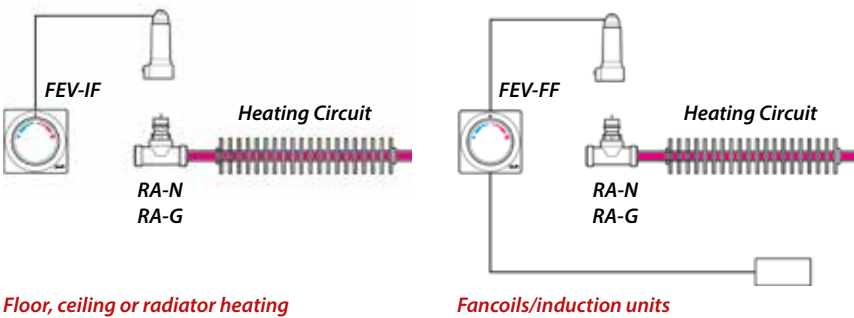

Floor, ceiling or radiator heating

Fancoils/induction units

- Proportional controllers for heating circuits
- Can be used with RA-N and RA-G
- FEV-IF can be used in floor, ceiling or radiator heating
- FEV-FF can be used with fancoil or induction units

The FEV is a proportional controller which opens or closes the heating valve as a function of the temperature deviation.

FEV sensors can be applied in combination with RA-N or RA-G valves. The FEV sensors are equipped with a direct acting valve-controller that opens the valve when the temperature drops below the set temperature. If the set temperature is equal to or higher than the room temperature the valve is closed.

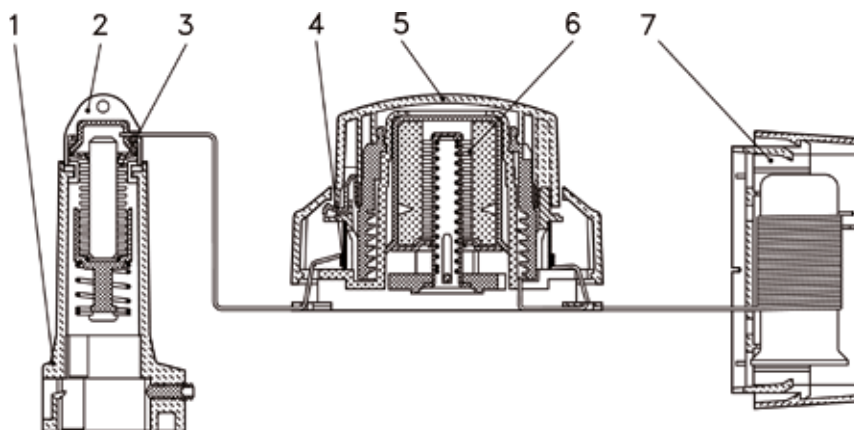

1. Heating adapter
2. Actuator
3. Adjustment bellows
4. Capillary reel
5. Remote temperature adjuster
6. Bellows
7. Remote temperature sensor (FEV-FF)

FEV-IF

To be applied in systems with ceiling, floor or radiator heating. The temperature adjuster/sensor should be mounted on an internal wall at a height of approximately 1.5 metres in such a way that the room temperature can be measured accurately.

FEV-FF

To be applied in systems with fancoils or induction units. By placing the remote sensor in the room-air inlet of the unit a smaller response time to temperature changes can be achieved which will result in a more accurate temperature control.

Lockshield Valves with Drain-Off RLV



- Straight or angled versions
- Use in 1 or 2 pipe systems
- Maximum flow temperature 120°C
- Maximum working pressure 10 bar

The RLV range of lockshield valves match the finish and style of RA-G, RA-FN and RA-N valve bodies. They are available in vertical angle and straight pattern versions in 3/8", 1/2" and 3/4" sizes for screwed pipe-work and 15mm for copper pipe-work.

Adjustment of the valve is made using a 6mm Allen key. Once set, a screw-on brass cover conceals the valve setting mechanism.

In addition to providing a balancing and isolation function, RLV lockshield valves also incorporate a drain-down/filling feature. To utilise this feature a drain-off accessory is mounted to the valve in place of the decorative cap. The system can then be drained down or filled by connecting a hose to the drain down adapter.

Pattern	Type	Code No	Connection Sizes	
			Pipe	Radiator
Vertical Angle	RLV 10	003L014100	3/8"	3/8"
	RLV 15	003L014300	1/2"	1/2"
	RLV 15	003L014315	15mm	1/2"
	RLV 15	003L182500	Press Fit	1/2"
	RLV 20	003L014500	3/4"	3/4"
Straight	RLV 10	003L014200	3/8"	3/8"
	RLV 15	003L014400	1/2"	1/2"
	RLV 15	003L014415	15mm	1/2"
	RLV 15	003L182400	Press Fit	1/2"
	RLV 20	003L014600	3/4"	3/4"

Drain-cock Adaptor and Compression Fittings for RLV Series Valves

Code No	Description
003L015200	Drain-cock adaptor for use with RLV models only, not RLV-S

Specification

Maximum working pressure	10 Bar
Maximum working temperature	120°C
Test pressure	16 Bar
Valve body finish	Nickel Plated
Gland seal type	Double O-ring
Supplied with LSV cap (nickel plated brass)	Yes
Supplied with wheel head cap	No

Dimensions

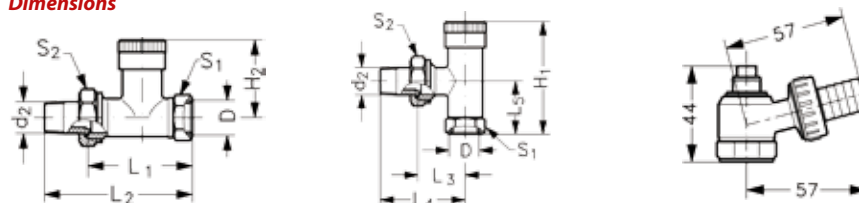

Type	D	d ₂	H ₁	H ₂	L ₁	L ₂	L ₃	L ₄	L ₅	S ₁	S ₂
RLV 10	R _p 3/8	R _p 3/8	55	40	49	75	26	52	22	22	27
RLV 15	R _p 1/2	R _p 1/2	59	40	51	80	29	58	27	27	30
RLV 20	R _p 3/4	R _p 3/4	62	42	59	91	34	66	30	32	37

Use of Drain Cock Adaptor

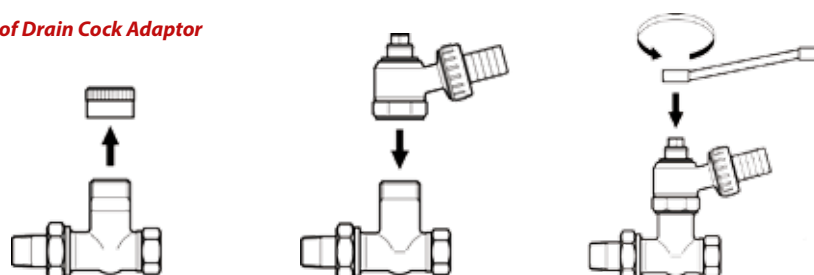

Lockshield Valves Without Drain-Off

RLV-S



Pattern	Type	Code No	Connection Sizes	
			Pipe	Radiator
Vertical Angle	RLV-S 10	003L012100	3/8"	3/8"
	RLV-S 15	003L012300	1/2"	1/2"
	RLV-S 15	003L012315	15mm	1/2"
	RLV-S 20	003L012500	3/4"	3/4"
Straight	RLV-S 10	003L012200	3/8"	3/8"
	RLV-S 15	003L012400	1/2"	1/2"
	RLV-S 15	003L012415	15mm	1/2"
	RLV-S 20	003L012600	3/4"	3/4"

- Straight or angled versions
- Use in 1 or 2-pipe systems
- Maximum flow temperature 120°C
- Maximum working pressure 10 bar

The RLV-S range of lockshield valves match the finish and style of RA-G, RA-FN and RA-N valve bodies. They are available in vertical angle and straight pattern versions in 3/8", 1/2" and 3/4" sizes for screwed pipe-work and 15mm for copper pipe-work.

Specification	
Maximum working pressure	10 Bar
Maximum working temperature	120°C
Test pressure	16 Bar
Valve body finish	Nickel Plated
Gland seal type	Double O-ring
Supplied with LSV cap (nickel plated brass)	Yes
Supplied with wheel head cap	No

Adjustment of the valve is made using a 6mm Allen key. Once set, a screw-on brass cover conceals the valve setting mechanism.

The RLV-S does not incorporate a drain down feature.

Dimensions

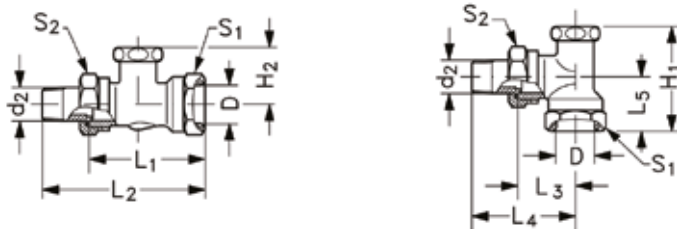

Type	D	d ₂	H ₁	H ₂	L ₁	L ₂	L ₃	L ₄	L ₅	S ₁	S ₂
RLV-S 10	G _p 3/8	R _p 3/8	42	26	51	75	27	51	23	22	27
RLV-S 15	G _p 1/2	R _p 1/2	52	28	53	80	30	57	27	27	30
RLV-S 20	G _p 3/4	R _p 3/4	52	28	61	92	34	65	30	32	37

Spare Parts and Accessories

Gland Seals, Sensors and Adapters



Gland Seal

- Just two gland seals cover the whole range of Danfoss valves
- Can be replaced without draining down the system

Replacement Sensor

- Allows easy up-grade of old valves without the need to drain down
- Versions available for RAVL and RAV valve bodies
- Available in built-in and remote sensor versions

Gland Seals

All gland seals in Danfoss radiator thermostats are designed to provide a long and trouble free in-service life. However, periodically it may be necessary to replace seals should failure occur.

All valves produced by Danfoss since early 1960s incorporate gland seal assemblies which can be replaced without draining down the system.

Valve Adaptor

Adaptors to convert RA2000 remote temperature adjusters for use with RAV and RAVL bodies already installed.

Manual Positive Shut-Off Dial

The RA manual positive shut-off dial fits onto all valve bodies in the RA Series and can be used for manual opening and closing of the valve.

Replacement Sensors

Replacement sensors incorporate RA2000 sensor technology and design, and provide a simple and straight forward way to upgrade older radiator thermostats without the need to drain down the system.

Gland Seals					
013G029000	Gland Seal Assembly for RA-FS, RA-FR, RA-FN, RA-N, RA-DV and RA-G Valves				
013U007000	Gland Seal Assembly for RAV and RAVL Valves				
Accessories for RA2000 Sensors and Valves					
013G123200	Anti-Theft for Sensors (50 pieces)				
013G123700	Threaded Range Limiting pins (30 pieces)				
013G123300	RA2020 Scale Cover (20 pieces)				
013G123600	Toolkit, comprising Allen Key and Locking Pin Tool				
013G123000	Accessory Bag for RA2000 Remote Sensor Base, Fixing Screw and Capillary Caps				
Accessories for RA2000 Remote Adjusters					
013G519300	Adaptor for RA5062, 5065 and 5068 for RAV Valves				
013G519200	Adaptor for RA5062, 5065 and 5068 for RAVL Valves				
Accessories for RA-FS, RA-FN, RA-N & RA-G Valves					
Code No	Description	RA-FS	RA-FN	RA-N	RA-G
013G500100	Blanking Cap for Valve Outlet	•			
013G027500	Spare Protective Cap	•	•	•	•
013G500200	RA Hand Wheel	•	•	•	•

Selecting a suitable replacement sensor

RAVL thermostats are replaced by RAVL

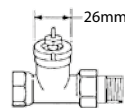

RAV thermostats are replaced by RAV

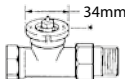

RA2000 Replacement Sensors and Gland Seals

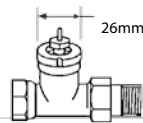
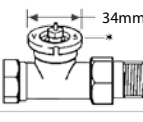
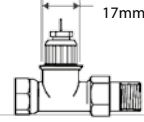
Existing Valve Body Dimensions	Existing Valve Body Type	Replacement Sensor - please note: the Code No's have changed				
		New Code No	Old Code No	Sensor Type	Description	Temp Range (Xp = 2k)
 26mm	RAVL	013G295000	013G221000	RA/VL	Built-In Sensor	5 - 26°C
		013G295200	013G221200	RA/VL	Remote Sensor 2m Capillary	
 34mm	RAV	013G296000	013G231000	RA/V	Built-In Sensor	5 - 26°C
		013G296200	013G231200	RA/V	Remote Sensor 2m Capillary	
 17mm	RA-FN RA-G RA-N	Refer to RA2000 Sensors on p. 16-19				

Compression Fittings For Copper, PEX and ALUPEX Pipe



For Valves with Female Threaded Connections

Compression Fittings for:	RA-FN, RA-N, RA-DV Radiator Thermostat Valve Bodies, RLV and RLV-S Lockshield
Pipe Type:	Copper
013G410000	3/8" x 10mm
013G410200	3/8" x 12mm
013G411000	1/2" x 10mm
013G411200	1/2" x 12mm
013G411500	1/2" x 15mm
Pipe Type:	PEX
013G414400	1/2" x 14 x 2.0mm
013G414700	1/2" x 15 x 2.5mm
013G415600	3/4" x 16 x 2.0mm
Pipe Type:	ALUPEX
013G417400	1/2" x 14 x 2mm

Please note: Copper pipe must be in accordance with BS2871 part 1/BSEN1057. It is recommended to use supporting bushes with soft copper pipes. PEX pipe must be in accordance with DIN16892/16893 or BS7291 part 1:1990 or part 3:1990. Maximum operating pressure and temperature are given by the pipe manufacturer. However, 6 bar and 95°C must not be exceeded.

Design: For use with valves having a female threaded connection. Fitting comprises olive and externally threaded compression nut, dimension of female thread is included in the description. For PEX and ALUPEX a pipe support insert is also included.

For Valves with Male Threaded Connections

Compression Fittings for:	RA-KE, RA-KEW and FHF-F
Pipe Type:	Copper
013G412000	3/4" x 10mm
013G412200	3/4" x 12mm
013G412500	3/4" x 15mm
Pipe Type:	PEX
013G415500	3/4" x 15mm x 2.5mm
013G416300	3/4" x 16mm x 2.2mm
013G415900	3/4" x 18mm x 2.5 mm
013G416100	3/4" x 20mm x 2.5mm
Pipe Type:	ALUPEX
013G418400	3/4" x 14mm x 2.0mm
013G418600	3/4" x 16mm x 2.0mm
013G418800	3/4" x 18mm x 2.0mm
013G419000	3/4" x 20mm x 2.0mm

Please note: Copper pipe must be in accordance with BS2871 part1/BSEN1057. It is recommended to use supporting bushes with soft copper pipes. PEX pipe must be in accordance with DIN16892/16893 or BS7291 part 1:1990 or part 3:1990. Maximum operating pressure and temperature are given by the pipe manufacturer. However, 6 bar and 95°C must not be exceeded.

Design: For use with valves having a 3/4" male threaded connection. Fitting comprises olive and internally threaded compression nut. For PEX and ALUPEX a pipe support insert is also included.



Motorised Control Valves

In a constantly evolving heating, ventilation and air conditioning (HVAC) market, it is important to improve flow and temperature control performance in every system and add essential features that offer high value for every customer. Danfoss has invested substantial development resources, which together with decades of experience has led to our new generation of intelligent and patented motorised control valves.

Our control valves are available in a range of different materials and with a variety of different connection types and sizes. Our motorised control valves range meets the requirements of virtually every application.



Contents

Special Functions of iMCV Electrical Actuators.....	26
Valve Sizing.....	27
Overview - Control Valves.....	28
Overview - Zone and Rotary Valves.....	29
Overview - Electrical Actuators.....	30
Combination Guide - Motorised Control Valves.....	31
VZL2 and VZL4 (2 and 4-Way Valves).....	32
AME 130(H)/140(H) Electric Actuators.....	33
AMV 130(H)/140(H) Electric Actuators.....	34
TWA-ZL Thermal Actuator.....	35
VRB2 (2-Port Seated Valves).....	36
VRB3 (3-Port Seated Valves).....	37
VF2 and VF3 (2 and 3-Port Seated Valves).....	38
AME 435 - Actuator for Modulating Control.....	39
AMV 435 - Actuator for 3-Point Control.....	40
AME 438 SU Spring Return - Actuator for Modulating Control.....	41
AMV 438 SU Spring Return - Actuator for 3-Point Control.....	42
AME 55 and AME 56 - Actuators for Modulating Control.....	43
AMV 55 and AMV 56 - Actuators for 3-Point Control.....	44
AME 85 and AME 86 - Actuators for Modulating Control.....	45
AMV 85 and AMV 86 - Actuators for 3-Point Control.....	46
AME 855 - Actuators for 3-Point Control.....	47
VFM2 - 2-Way Seated Control Valve.....	48
AMV 655 and AMV 658 - Actuators for 3-Point Control.....	49
AME 655 and AME 658 - Actuators for Modulating Control.....	49
HRB3 and HRB4 Brass Rotary Valves.....	50
HRE3 and HRE4 Cast Iron Rotary Valves.....	51
AMB 162 and AMB 182 Rotary Actuators.....	52
AMZ 112, 113 and 122 Motorised Zone Valves.....	53
VFY-WA Butterfly Valves.....	54
AMD - Electrical Actuators for Air Dampers.....	55

Special Functions of iMCV Electrical Actuators



Self-stroking

The electrical actuator automatically adjusts to end positions of the control valve.

The self-stroking procedure starts by extracting the actuator stem. When the maximum force is detected at the end valve position, the actuator retracts the stem until the maximum force is detected again (on the other end position of the control valve).

Anti-oscillation function

This function tracks oscillations in systems that are oversized or poorly controlled. It adjusts the actuator response to minimise hunting. This reduces temperature variations and improves comfort for HVAC system users.

LED indicator

The LED indicator helps the user recognise the operating mode or function of the actuator at all times. Different colours or blinking signals are used to indicate different modes.

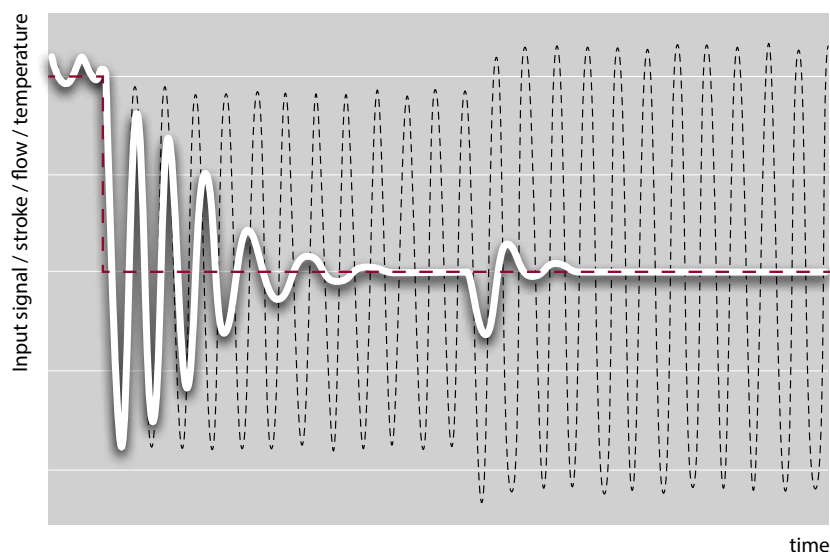
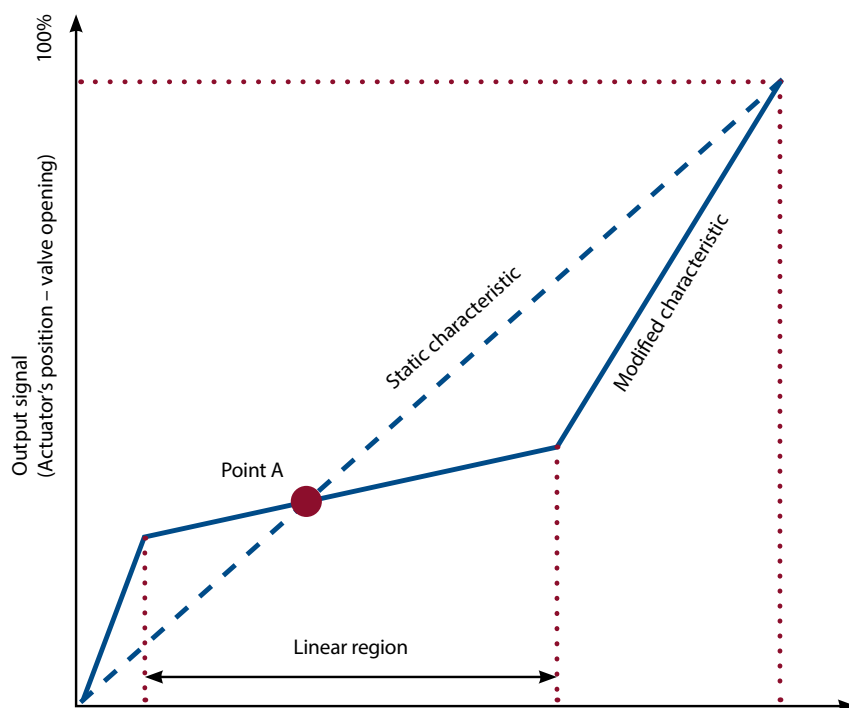

Valve Sizing

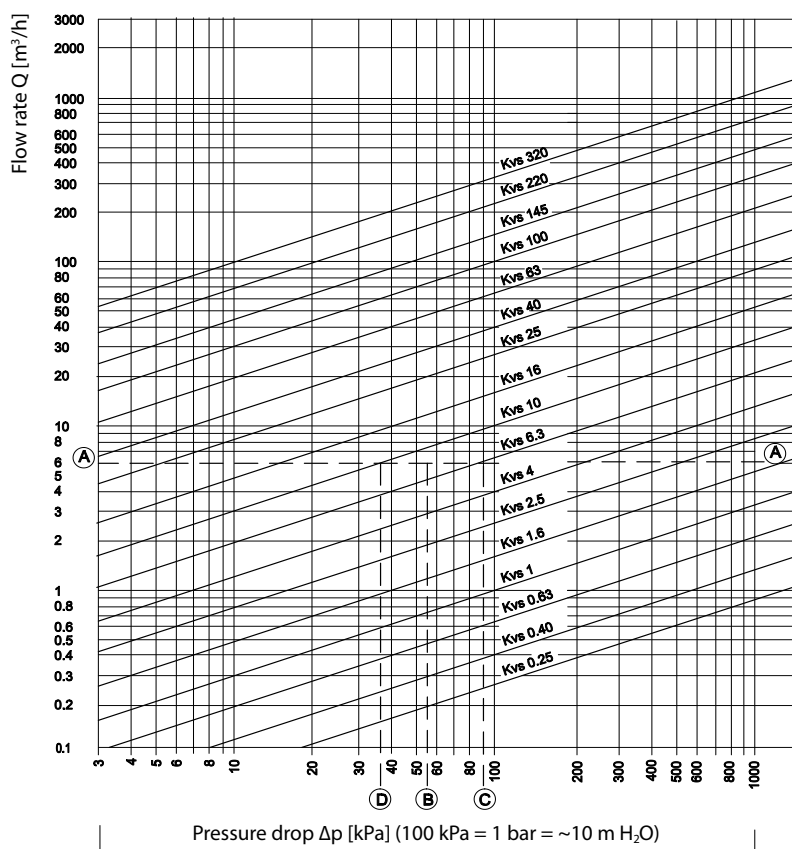

Example – Design data:
 Flow rate: 6 m³/h
 System pressure drop: 55 kPa

Locate the horizontal line representing a flow rate of 6 m³/h (line A-A). The valve authority is given by the equation:

$$\text{Valve authority, } a = \frac{\Delta p_1}{\Delta p_1 + \Delta p_2}$$

Where:

Δp_1 = pressure drop across the fully open valve

Δp_2 = pressure drop across the rest of the circuit with a full open valve

The ideal valve would give a pressure drop equal to the system pressure drop (i.e. an authority of 0.5):

if: $\Delta p_1 = \Delta p_2$

$$a = \frac{\Delta p_1}{\Delta p_1 + \Delta p_2}$$

In this example an authority of 0.5 would be given by a valve having a pressure drop of 55 kPa at the specified flow rate. (point B). The intersection of line A-A with a vertical line drawn from B lies between two diagonal lines; this means that no ideally-sized valve is available.

The intersection of line A-A with the diagonal lines gives the pressure drops produced by real (rather than ideal) valves. In this case, a valve with k_{vs} 6.3 would give a pressure drop of 90.7 kPa (point C):

$$\text{hence valve authority} = \frac{90.7}{90.7 + 55} = 0.62$$

The second largest valve, with k_{vs} 10, would give a pressure drop of 36 kPa (point D):

$$\text{hence valve authority} = \frac{36}{36 + 55} = 0.395$$

With a three-port application, the usual practice is to select the smaller valve because this yields a valve authority greater than 0.5, and therefore better control. However, this will increase the total pressure and should be checked by the system designer for compatibility with available pump heads, etc. The ideal authority is 0.5, with a preferred range of 0.5 to 0.8.

Overview

Control Valves



iMCV Valves		VRB 2	VRB 3	VF 2	VF 3	VFM 2
Technical Data		Page 36	Page 37	Page 38		Page 48
Valve type		Seated valve		Seated valve		Seated valve
Material		Red bronze		Grey cast iron (DN 15-100) Ductile iron (DN 125-300)		Grey cast iron
Connection		Internal or external thread		Flanged		Flanged
Nominal Pressure	PN	PN16		PN 16		PN 16
Max. closing pressure	bar	4		1.5 / 2.5 / 3 / 4 ¹		1.5
Ports		2	3	2	3	2
Medium temperature		(-10) ² 2...130		(-10) ² 2...130 (200) ¹		(-10) ² 2...150
DN		15 ... 50		15 ... 300		65 ... 250
k _{vs}	m ³ /h	0.63 ... 40		0.63 ... 320		0.63 ... 900
Control characteristic		Logarithmic	Log: port A-AB Lin: port B-AB	Logarithmic	Log: port A-AB Lin: port B-AB	Lin (30%) Log (70%)
Control range		30:1 / 50:1 / 100:1 ¹		30:1 / 50:1 / 100:1 / 750:1 ¹		100:1
Leakage		Bubble tight	A - AB ≤ bubble tight B - AB ≤ 1% of k _{vs}	Bubble tight	A - AB ≤ bubble tight B - AB ≤ 1% of k _{vs}	<0.03% of k _{vs}
Stroke	mm	10 / 15 ¹		10 / 15 / 20 / 30 / 40 / 70 / 80 ¹		30 / 34 / 40 / 50
Sealing type		Soft sealing		10 / 15 / 20 / 30 / 40 ¹		30 / 34 / 40 / 50

¹ Values are depending on size or different k_{vs} type. Please see control valves section for detailed information.

² With stem heater

Fan Coil Valves		VZL 2	VZL 4
Technical Data		Page 32	
Valve type		Seated valve	
Material		Brass	
Connection		External thread	
Nominal Pressure	PN	PN 16	
Max. closing pressure	bar	1 / 2 / 2.5 ¹	
Ports		2	4
Medium temperature		2 ... 120	
DN		15 ... 20	
k _{vs}	m ³ /h	0.25 ... 3.5	
Control characteristic		Linear	
Control range		≥ 30:1	
Leakage		A - AB ≤ 0.05% of k _{vs} B - AB ≤ 1% of k _{vs}	
Stroke	mm	2.8	
Sealing type		metal sealing	

¹ Values are depending on size or different k_{vs} type. Please see control valves section for detailed information.

Overview

Zone and Rotary Valves



Motorised Control Valves

Zone and Rotary Valves		AMZ 112	AMZ 113	HRB 3	HRB 4	HRE 3	HRE 4
Technical Data		Page 53		Page 50		Page 51	
Valve type		Ball valve - on/off zone valve incl. actuator		Rotary valve		Rotary valve	
Material		Nickel-plated brass		Dezincification resistant brass		Grey cast iron	
Connection		Internal thread		Internal thread (ISO 7/1)		Internal thread (ISO 7/1)	
Nominal Pressure	PN	PN 16		PN 10		PN 6	
Max. closing pressure	bar	6		Diverting: 2 bar Mixing: 1 bar		1 bar	
Ports		2	3	3	4	3	4
Medium temperature		2 ... 130		2 ... 110		2 ... 110	
DN		15 ... 32		15 ... 50		20 ... 50	
kvs	m ³ /h			0.4 ... 40		6.3 ... 40	
Max. torque	Nm	8		5		5	
Leakage		Leakage class A		0.05% k _{V5}	1% k _{V5}	0.05% k _{V5}	1% k _{V5}

¹ Values are depending on size or different kVS type. Please see control valves section for detailed information.

Overview

Electrical Actuators

Electrical Actuators		AME 435	AMV 435	AME 438 SU	AMV 438 SU	AME 55	AME 56	AMV 55	AMV 56	AME 85	AME 86	AMV 85	AMV 86	AME 855
Technical spec.		Page 39	Page 40	Page 41	Page 42	Page 43	Page 44	Page 45	Page 46	Page 47			Page 47	
Actuator type		Electric		Electric		Electric				Electric				
Control input		modulating	3-point	modulating	3-point	modulating	3-point	modulating	3-point	modulating	3-point	modulating	3-point	3-point modulating
Closing force	N	400		450	450	2000	1500	2000	1500	5000	5000	5000	5000	15000
Speed	mm/s	7.5 or 15		15	15	8	4	8	4	8	3	8	3	2
Max stroke	mm	20		15	15	40				40				70(DN200-250) 80(DN300)
Power supply	V	24	24 or 230	24	24 or 230	24	24 or 230	24	24 or 230	24	24 or 230	24	24 or 230	24 or 230
Safety function		-		spring up	spring up	-				-				-
Grade of enclosure		IP 54		IP 54		IP 54				IP 54				IP 54
Special functions														
Self-stroking		•		•		•	•			•	•			•
Anti oscillation function		•												
LED indicator		•		•		•	•			•	•			•
Manual operation		•	•			•	•	•	•	•	•	•	•	•
Tool-free mounting		•	•											
Characteristic selection switch		•		•		•	•			•	•			





Electrical Actuators		AME 130	AME 130H	AMV 130	AMV 130H	AME 140	AME 140H	AMV 140	AMV 140H	AMB 162	AMB 182	TWA - ZL
Technical spec.		Page 33-34				Page 33-34				Page 52		Page 35
Actuator type		Electric				Electric				Electric		Thermal
Control input		modulating	3-point	modulating	3-point	modulating	3-point	3-point/modulating**	3-point/modulating**	2-point (on/off)		
Closing force	N	200				200				5nm	10/15nm	90
Speed	mm/s	24				12				15/30/60/120/480s - 90° (60/90/120s - 90°*		Full stroke time approx. 3 min
Max stroke	mm	5.5				5.5				-		2.8
Power supply	V	24	24 or 230	24	24 or 230	24	24 or 230	24 or 230	24 or 230	24 or 230	24 or 230	
Safety function		-				-				-		-
Grade of enclosure		IP 42				IP 42				IP 42		IP 41
Special functions												
Self-stroking		•	•			•	•					-
Anti oscillation function												-
LED indicator												-
Manual operation		•	•	•	•	•	•	•	•	•	•	-
Tool-free mounting		•	•	•	•	•	•	•	•	•	•	-
Characteristic selection switch		•	•	•	•	•	•	•	•			-

* Modulating ** 3-point controlled models with AS versions

Combination Guide

Motorised Control Valve

		Actuator type			AMV(E) 435	AMV(E) 438 SU	AMV(E) 56	AMV(E) 85	AMV(E) 86	AMV(E) 655	AMV(E) 658	AMV 855			
Valve type	DN	k_{vs} [m ³ /h]	stroke [mm]	Δp clos. [bar]	Δp clos. [bar]	Δp clos. [bar]	Δp clos. [bar]	Δp clos. [bar]	Δp clos. [bar]	Δp clos. [bar]	Δp clos. [bar]	Δp clos. [bar]			
												Mixing	Diverting		
 VRB 2/3	15	0.63; 1; 1.6; 2.5; 4	10	4	4										
	20														
	25														
	32														
	40														
 VF 2/3/4	15	0.63; 1; 1.6; 2.5; 4	10	4	4										
	20														
	25														
	32														
	40														
	50														
	20		65	15	2.5										
			80												
			100												
			125												
			150												
			200												
70	250	30													
	300														
	1250														
	80														
	70														
	80														
 VFM 2	65	63													
	80														
	100														
	150														
	200														
	250														
	900														

		Actuator type			TWA - ZL	AMV(E) 130(H)	AMV(E) 140(H)	AMB 162	AMB 182								
Valve type	DN	k_{vs} [m ³ /h]	stroke [mm]	Δp clos. [bar]	Δp clos. [bar]	Δp clos. [bar]	Δp clos. [bar]	Δp clos. [bar]	Δp clos. [bar]								
										 VZL 2/3/4	15	0.25; 0.4; 0.63	2.8	2.5	2.5	2.5	
20																	
25																	
 VZ 2/3/4	15	0.25; 0.4; 0.63; 1.0; 1.6; 2.5	5.5														
	20																
 HRB3/4	15	0.4															
		0.63															
		1.0															
		1.63															
		2.5															
		4.0															
	20	2.5															
		4.0															
		6.3															
		6.3															
		10															
		16															
25	25																
	40																
	50																
	40																
 HRE3/4	20	6.3															
	25																
	32																
	40																
	50																

Fan Coil Valves

VZL 2 and VZL 4



- Push connection between valve and actuator
- Design that prevents sticking in closed position
- Linear characteristic
- Suitable to run together with thermic actuator TWA-ZL

VZL valves provide a high quality, cost effective solution for the control of hot and/or chilled water for fan coil units, small reheaters, and recoolers in temperature control systems.

Applications

HVAC applications (water side).

Compatible Actuators

AMV 130/140.....	Page 34
AME 130/140.....	Page 33
AMV 130H/140H.....	Page 34
AME 130H/140H.....	Page 33
TWA-ZL.....	Page 35

VZL 2

DN	k_{vs} (m ³ /h)	max Δp (bar)	Code number	
			Flat End	Compression
15	0.25	2.5	065Z207000	065Z204000
	0.4		065Z207100	065Z204100
	0.63		065Z207200	065Z204200
	1	2	065Z207300	065Z204300
	1.6		065Z207400	065Z204400
20	2.5	1	065Z207500	065Z204500
	3.5		065Z207600	065Z204600

VZL 4

DN	k_{vs} (A-AB) (m ³ /h)	k_{vs} (B-AB) (m ³ /h)	max Δp (bar)	Code number	
				Flat End	Compression
15	0.25	0.25	2.5	065Z209000	065Z206000
	0.4	0.25		065Z209100	065Z206100
	0.63	0.4		065Z209200	065Z206200
	1	0.63	2	065Z209300	065Z206300
	1.6	1		065Z209400	065Z206400
20	2.5	1.6	1	065Z209500	065Z206500
	3.5	2.5		065Z209600	065Z206600

Nominal diameter	DN	15	20
Stroke	mm	2.8	
Control range		min. 30:1	
Control characteristic		Linear	
Leakage		A - AB \leq 0.05% of k_{vs} B - AB \leq 1% of k_{vs}	
Nominal pressure	PN	16	
Medium		Circulation water / Glycolic water up to 50%	
Medium pH		Min. 7, Max. 10	
Medium temperature	°C	2 ... 120	
Connections		External thread (flat end (MS 58) or compression)	
Materials			
Body, seat, cone and stem		Brass	
Stuffing box sealing		EPDM	

Operating Range

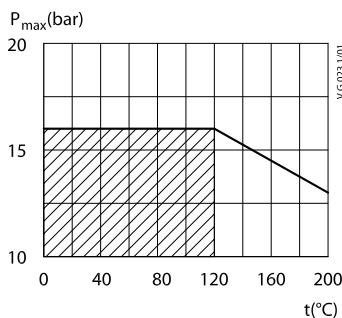

Actuators for Modulating Control

AME 130(H) and AME 140(H)



Type	Supply voltage	Speed	Code number
AME 130	24 V AC	24 mm/s	082H804400
AME 140		12 mm/s	082H804500
AME 130H		24 mm/s	082H804600
AME 140H		12 mm/s	082H804700

- Modulating control
- Load related "switch off" function that prevents overloading
- Manual operation (only H version)

AME 130, AME 140, AME 130H and AME 140H actuators are used with VZL valves. Actuators marked with "H" enable hand operation. The actuator can be used with fan coil units, induction units, small reheaters, recoolers, and zone applications in which hot/cold water is the controlled medium.

Applications

Operation of fan coil valves.

Compatible Valves

VZL.....Page 32

Type		AME 130, AME 130H	AME 140, AME 140H
Power supply	V	24 AC; +10 to -15%	
Power consumption	VA	1.3	
Frequency	Hz	50/60	
Control input Y	V	0-10 (2-10)	
	mA	0-20 (4-20)	
Output signal X	V	0-10 (2-10)	
Closing force	N	200	
Max. stroke	mm	5.5	
Speed	mm/s	24	12
Max. medium temperature	°C	130	
Ambient temperature	°C	0 ... 55	
Storage and transport temperature	°C	-40 ... +70	
Grade of enclosure		IP 42	
Weight	kg	0.3	
CE marking in accordance with standards		Low Voltage Directive (LVD) 2006/95/EC: EN 60730-1, EN 60730-2-14 EMC Directive 2004/108/EC: EN 61000-6-2, EN 61000-6-3	



Actuators for 3-Point Control

AMV 130(H) and AMV 140(H)



- Load related “switch off” function that prevents overloading
- Manual operation (only H version)

AMV 130, AMV 140, AMV 130H and AMV 140H actuators are used with VZL valves. Actuators marked with “H” enable hand operation. The actuator can be used with fan coil units, induction units, small reheaters, recoolers, and zone applications in which hot/cold water is the controlled medium.

Applications

Operation of fan coil valves.

Compatible Valves

VZL..... Page 32

Type	Supply voltage	Speed	Code number
AMV 130	24 V AC	24 mm/s	082H803600
AMV 140		12 mm/s	082H803800
AMV 130H		24 mm/s	082H804000
AMV 140H		12 mm/s	082H804200
AMV 130	230 V AC	24 mm/s	082H803700
AMV 140		12 mm/s	082H803900
AMV 130H		24 mm/s	082H804100
AMV 140H		12 mm/s	082H804300

Type		AMV 130, AMV 130H	AMV 140, AMV 140H
Power supply	V	24 AC, 230 AC; +10 to -15%	
Power consumption	VA	1 (24 V AC); 8 (230 V AC)	
Frequency	Hz	50/60	
Control input		3-point	
Closing force	N	200	
Max. stroke	mm	5.5	
Speed	mm/s	24	12
Max. medium temperature	°C	130	
Ambient temperature	°C	0 ... 55	
Storage and transport temperature	°C	-40 ... +70	
Grade of enclosure		IP 42	
Weight	kg	0.3	
CE marking in accordance with standards		Low Voltage Directive (LVD) 2006/95/EC: EN 60730-1, EN 60730-2-14 EMC Directive 2004/108/EC: EN 61000-6-2, EN 61000-6-3	



Thermal Actuator TWA-ZL



Type	Supply voltage	Code number
TWA-ZL NC	24 V AC/DC	082H310000
TWA-ZL NO		082H310100
TWA-ZL NC	230 V AC	082H310200
TWA-ZL NO		082H310300

- Position indicator

Danfoss thermal actuator TWA-ZL is used with Danfoss valves type VZL. The actuator can be controlled with a on/off controller or switch. These provide a cost effective solution for the control of hot and /or chilled water for fan coil units, small reheaters and recoolers in temperature control systems.

Applications

Operation of fan coil valves.

Compatible Valves

VZL.....Page 32

Specification		
Power supply	V	24 AC/DC or 230 AC
Power consumption	VA	2
Frequency	Hz	50/60
Control input		ON/OFF
Closing force	N	90
Max. stroke	mm	2.8
Full stroke time	min	3 ¹⁾
Max. medium temperature	°C	120
Ambient temperature	°C	2 ... 60
Storage and transport temperature	°C	-40 ... +70
Protection Class		II
Grade of enclosure		IP 41
Weight	kg	0.15
Cable length	m	1.2

¹⁾ When heating the actuator full stroke time increases up to some minutes
– it depends on ambient temperature



2-Port Seated Valves

VRB 2



- Snap mechanical connection together with AMV(E) 435
- Soft sealing
- Logarithmic characteristic
- Control range up to 100:1
- Internal or external thread connection
- Dedicated 2-port valve

VRB valves provide a quality, cost effective solution for most water and chilled applications.

The valves are designed to be combined with AMV(E) 435 or AMV(E) 438 SU actuators.

Applications

Heating systems and HVAC applications (water side).

Compatible Actuators

AMV 435.....	Page 40
AME 435.....	Page 39
AMV 438SU.....	Page 42
AME 438 SU.....	Page 41

Operating Range

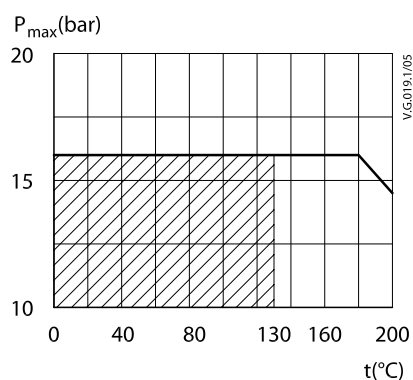

Valves

DN	k _{vs} (m ³ /h)	Code number	
		Internal thread	External thread *
15	0.63	065Z023100	065Z017101
	1	065Z023200	065Z017201
	1.6	065Z023300	065Z017301
	2.5	065Z023400	065Z017401
20	4	065Z023500	065Z017501
	6.3	065Z023600	065Z017601
25	10	065Z023700	065Z017701
32	16	065Z023800	065Z017801
40	25	065Z023900	065Z017901
50	40	065Z024000	065Z018001

* c/w tails

Technical Data

Nominal diameter	DN	15		20	25	32	40	50			
k _{vs} value	m ³ /h	0.63	1.0	1.6	2.5	4.0	6.3	10	16	25	40
Stroke	mm	10						15			
Control range		30:1	50:1				100:1				
Control characteristic		Logarithmic									
Cavitation factor z		≥ 0.4									
Leakage		Bubble tight									
Nominal pressure	PN	16									
Max. closing pressure	bar	4									
Medium		Circulation water / glycolic water up to 50%									
Medium pH		Min. 7, Max. 10									
Medium temperature	°C	2 (-10 ¹⁾) ... 130									
Connections		Internal or external thread									
Materials											
Valve body		Red bronze (Rg5)									
Valve stem		Stainless steel									
Valve cone		Dezincification resistant brass									
Stuffing box sealing		EPDM									

¹⁾ At temperatures from -10 up to +2 °C use stem heater

3-Port Seated Valves

VRB 3



Valves

DN	k _{vs} (m ³ /h)	Code number	
		Internal thread	External thread *
15	0.63	065Z021100	065Z015101
	1	065Z021200	065Z015201
	1.6	065Z021300	065Z015301
	2.5	065Z021400	065Z015401
	4	065Z021500	065Z015501
20	6.3	065Z021600	065Z015601
25	10	065Z021700	065Z015701
32	16	065Z021800	065Z015801
40	25	065Z021900	065Z015901
50	40	065Z022000	065Z016001

* c/w tails

- Snap mechanical connection together with AMV(E) 435
- Soft sealing
- Logarithmic characteristic A-AB and linear characteristic B-AB
- Control range up to 100:1
- Internal or external thread connection
- Suitable for diverting applications

VRB valves provide a quality, cost effective solution for most water and chilled applications.

The valves are designed to be combined with AMV(E) 435 or AMV(E) 438 SU actuators.

Technical Data

Nominal diameter	DN	15					20	25	32	40	50	
k _{vs} value	m ³ /h	0.63	1.0	1.6	2.5	4.0	6.3	10	16	25	40	
Stroke	mm	10						15				
Control range		30:1	50:1				100:1					
Control characteristic		Logarithmic: port A-AB; Linear: port B-AB										
Cavitation factor z		≥ 0.4										
Leakage		A - AB bubble tight B - AB ≤ 1.0% of k _{vs}										
Nominal pressure	PN	16										
Max. closing pressure	bar	Mixing: 4 Diverting: 1										
Medium		Circulation water / glycolic water up to 50%										
Medium pH		Min. 7, Max. 10										
Medium temperature	°C	2 (-10 ¹⁾) ... 130										
Connections		Internal or external thread										
Materials												
Valve body		Red bronze (Rg5)										
Valve stem		Stainless steel										
Valve cone		Dezincification resistant brass										
Stuffing box sealing		EPDM										

¹⁾ At temperatures from -10 up to +2 °C use stem heater

Applications

Heating systems and HVAC applications (water side).

Compatible Actuators

AMV 435.....	Page 40
AME 435.....	Page 39
AMV 438SU.....	Page 42
AME 438 SU.....	Page 41

Operating Range

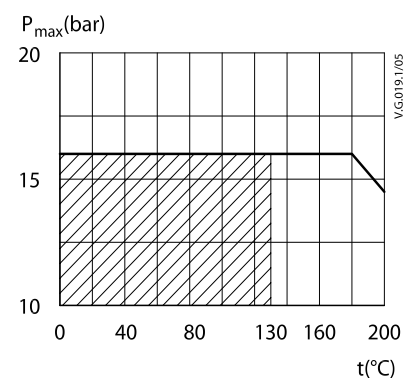

2 and 3-Port Seated Valves

VF 2 and VF 3



- Snap mechanical connection together with AMV(E) 435
- Soft sealing up to DN 80
- Logarithmic characteristic A-AB and linear characteristic B-AB
- Control range up to 100:1
- Flanged PN16 connection
- Dedicated 2-port valve
- Suitable for diverting applications

VF 2 and VF 3 valves provide a quality, cost effective solution for most water and chilled applications.

Applications

Heating systems and HVAC applications (water side).

Compatible Actuators

AMV 435	DN15-80	Page 40
AME 435	DN15-80	Page 39
AMV 438 SU	DN15-50	Page 42
AME 438 SU	DN15-50	Page 41
AMV 55	DN 100, 125, 150	Page 44
AME 55	DN 100, 125, 150	Page 43
AMV 56	DN 100, 125, 150	Page 44
AME 56	DN 100, 125, 150	Page 43
AMV 85	DN 125, 150	Page 46
AME 85	DN 125, 150	Page 45
AMV 86	DN 125, 150	Page 46
AME 86	DN 125, 150	Page 45
AME 855	DN 200, 300	Page 47

¹⁾ Only for DN 15 k_{vs} 0.63

²⁾ For actuators AMV(E) 56

³⁾ For actuators AMV(E) 55

⁴⁾ For actuators AMV(E) 85, AMV(E) 86

⁵⁾ At temperatures from -10 up to +2 °C use stem heater

DN	k_{vs} (m ³ /h)	Code number	
		VF 2	VF 3
15	0.63	065Z027100	065Z025100
	1	065Z027200	065Z025200
	1.6	065Z027300	065Z025300
	2.5	065Z027400	065Z025400
20	4	065Z027500	065Z025500
	6.3	065Z027600	065Z025600
25	10	065Z027700	065Z025700
32	16	065Z027800	065Z025800
40	25	065Z027900	065Z025900
50	40	065Z028000	065Z026000
65	63	065Z028100	065Z026100
80	100	065Z028200	065Z026200
100	145	065B320500	065B168500
125	220	065B323000	065B312500
150	320	065B325500	065B315000
200	630	-	065B420000
250	1000	-	065B425000
300	1250	-	065B430000

Nominal diameter	DN	15	20	25	32	40	50	65	80	100	125	150	200	250	300		
Stroke	mm	10		15			20		30	40		70		80			
Control range		50:1 (30:1) ¹⁾		100:1						>50:1							
Control characteristic		Logarithmic: port A-AB; Linear: port B-AB															
Cavitation factor z		≥ 0.4										≥ 0.45					
Leakage		A - AB bubble tight															
		B - AB ≤ 1.0% of k_{vs}															
Nominal pressure	PN	16															
Max. closing pressure (mixing)	bar	4			2.5		1.0 ²⁾ 1.5 ³⁾	0.5 ²⁾ 1.0 ³⁾ 3.0 ⁴⁾	0.2 ²⁾ 0.5 ³⁾ 1.5 ⁴⁾	3.7	2.2	1.5					
Max. closing pressure (diverting)	bar	1			Not applicable						2.0	1.5	1.0				
Medium		Circulation water / glycolic water up to 50%															
Medium pH		Min. 7, Max. 10															
Medium temperature	°C	2 (-10 ⁵⁾ ... 130						2 (-10 ⁵⁾ ... 200			2 (-10) ... 130						
Connections		Flange PN 16 acc. to EN 1092-2															
Materials																	
Valve body		Grey cast iron (GG-25)							Ductile iron (GGG 40)			Grey cast iron (GG-25)					
Valve stem		Stainless steel															
Valve cone		Dezincification resistant brass							Red bronze (Rg 5)	Ductile iron (GGG 40)			Stainless steel				
Stuffing box sealing		EPDM							PTFE			EPDM					

Actuator for Modulating Control

AME 435



Actuator

Type	Supply voltage	Code number
AME 435	24 V AC/DC	082H016100

Accessories

Type	DN	Power supply	Code number
Stem heater*	15-80	24 V AC	065Z031500

* For valve types VRB, VRG, VF and VL gen. 2009

Adapter

Valves	DN	max. Δp (bar)	Code number
For old VRB, VRG, VF and VL valves	15	9	065Z031300
	20	4	
	25	2	
	32	1	
	40	0.8	
	50	0.5	

Technical data

Power supply	V	24 AC/DC; $\pm 10\%$
Power consumption	VA	4.5
Frequency	Hz	50/60
Control input Y	V	0-10 (2-10) [Ri = 95 k Ω]
	mA	0-20 (4-20) [Ri = 500 Ω]
Output signal X	V	0-10 (2-10) [RL = 650 Ω (maximal load)]
Closing force	N	400
Max. stroke	mm	20
Speed	mm/s	7.5 or 15
Max. medium temperature	$^{\circ}\text{C}$	130
Ambient temperature	$^{\circ}\text{C}$	0 ... 55
Storage and transport temperature	$^{\circ}\text{C}$	-40 ... +70
Protection class		II
Grade of enclosure		IP 54
Weight	kg	0.45
CE marking in accordance with standards	Low Voltage Directive (LVD) 2006/95/EC: EN 60730-1, EN 60730-2-14 EMC Directive 2004/108/EC: EN 61000-6-2, EN 61000-6-3	

- "Self stroking" function
- Load related "switch off" function that prevents overloading
- Manual operation
- Position indication
- LED signalling
- Multifunctional DIP switch: speed selection, input range selection, signal inversion, characteristic setup and anti-oscillation
- Tool-free mounting
- Auto detection of input (Y) signal
- External RESET Button

AME 435 actuator is used with two and three way valves type VRB and VF up to DN 80 diameter.

Applications

Operation of seated valves.

Compatible Valves

VRB 2	Page 36
VRB 3	Page 37
VF 2	Page 38
VF 3	Page 38
VFM2	Page 48



Actuator for 3-Point Control

AMV 435



- "Self stroking" function
- Load related "switch off" function that prevents overloading
- Manual operation
- Position indication
- LED signalling
- DIP switch for speed selection
- Tool-free mounting

AMV 435 actuator is used with two and three way valves type VRB and VF up to DN 80 diameter.

Applications

Operation of seated valves.

Compatible Valves

VRB 2	Page 36
VRB 3	Page 37
VF 2	Page 38
VF 3	Page 38
VFM2	Page 48



Actuator

Type	Supply voltage	Code number
AMV 435	24 V AC/DC	082H016200
	230 V AC	082H016300

Accessories

Type	DN	Power supply	Code number
Stem heater*	15-80	24 V AC	065Z031500

* For valve types VRB, VRG, VF and VL gen. 2009

Adapters

Valves	DN	max. Δp (bar)	Code number
For old VRB, VRG, VF and VL valves	15	9	065Z031300
	20	4	
	25	2	
	32	1	
	40	0.8	
	50	0.5	

Technical data

Power supply	V	24 AC/DC, 230 AC; +10 to -15%
Power consumption	VA	2
Frequency	Hz	50/60
Control input		3 point
Closing force	N	400
Max. stroke	mm	20
Speed	mm/s	7.5 or 15
Max. medium temperature	°C	130
Ambient temperature	°C	0 ... 55
Storage and transport temperature	°C	-40 ... +70
Protection class		II
Grade of enclosure		IP 54
Weight	kg	0.45
CE marking in accordance with standards		Low Voltage Directive (LVD) 2006/95/EC: EN 60730-1, EN 60730-2-14 EMC Directive 2004/108/EC: EN 61000-6-2, EN 61000-6-3

Actuator for Modulating Control

AME 438 SU

Spring Return



Actuator

Type	Supply voltage	Code number
AME 438 SU	24 V AC	082H012100

Accessories

Type	DN	Code number
Stem heater*	15-50	065Z031500

* For valve types VRB, VRG, VF and VL gen. 2009

- "Self stroking" function
- Load related "switch off" function that prevents overloading
- Spring up function (safety)

AME 438 SU actuator is used with two and three-way valves type VRB, VRG, VF and VL up to DN 50 diameter.

Applications

Operation of seated valves.

Compatible Valves

VRB 2	Page 36
VRB 3	Page 37
VF 2	Page 38
VF 3	Page 38
VFM2	Page 48

Technical data		
Power supply	V	24 AC; ±10%
Power consumption	VA	14
Frequency	Hz	50/60
Control input Y	V	0-10 (2-10) [Ri = 24 kΩ]
	mA	0-20 (4-20) [Ri = 500 Ω]
Output signal X	V	0-10 (2-10)
Closing force	N	450
Max. stroke	mm	15
Speed	mm/s	15
Max. medium temperature	°C	150
Ambient temperature	°C	0 ... 55
Storage and transport temperature	°C	-40 ... +70
Protection class		II
Grade of enclosure		IP 54
Weight	kg	2.3
CE marking in accordance with standards		Low Voltage Directive (LVD) 2006/95/EC: EN 60730-1, EN 60730-2-14 EMC Directive 2004/108/EC: EN 61000-6-2, EN 61000-6-3



Actuator for 3-Point Control

AMV 438 SU

Spring Return



- Load related "switch off" function that prevents overloading
- Spring up function (safety)

AMV 438 SU actuator is used with two and three-way valves type VRB, VRG, VF and VL up to DN 50 diameter.

Applications

Operation of seated valves.

Compatible Valves

VRB 2	Page 36
VRB 3	Page 37
VF 2	Page 38
VF 3	Page 38
VFM2	Page 48



Actuator

Type	Supply voltage	Code number
AMV 438 SU	24 V AC	082H012200
	230 V AC	082H012300

Accessories

Type	Code number
Additional switches (2x)	082H701500
Additional switches (2x) and potentiometer (10k Ω)	082H701600
Additional switches (2x) and potentiometer (1k Ω)	082H701700
Stem heater*	06SZ031500

* For valve types VRB, and VF gen. 2009

Technical data

Power supply	V	24 AC, 230 AC; +10 to -15%
Power consumption	VA	12
Frequency	Hz	50/60
Control input		3 point
Closing force	N	450
Max. stroke	mm	15
Speed	mm/s	15
Max. medium temperature	°C	150
Ambient temperature	°C	0 ... 55
Storage and transport temperature	°C	-40 ... +70
Protection class		II
Grade of enclosure		IP 54
Weight	kg	2.3
CE marking in accordance with standards		Low Voltage Directive (LVD) 2006/95/EC: EN 60730-1, EN 60730-2-14 EMC Directive 2004/108/EC: EN 61000-6-2, EN 61000-6-3

Actuator for Modulating Control

AME 55 and AME 56



Actuator

Type	Supply voltage	Code number
AME 55	24 V AC	082H302200
AME 56		082H302500

Accessories

Type	Code number
Active return signal kit for AME 55, AME 56	082H307000
Stem heater (VF, VL valves DN 100)	065Z702000
Stem heater (VF valves DN 125, 150)	065Z702200

- "Self stroking" function
- Load related "switch off" function that prevents overloading
- Manual operation

The actuators AME 55 and AME 56 are used with VF 2, VF 3 valves from DN 100 up to DN 150 diameter.

Applications

Operation of seated valves.

Compatible Valves

VF 2	Page 38
VF 3	Page 38

Technical data		AME 55	AME 56
Type			
Power supply	V	24 AC; $\pm 10\%$	
Power consumption	VA	9	19.5
Frequency	Hz	50/60	
Control input Y	V	0-10 (2-10) [Ri = 24 k Ω]	
	mA	0-20 (4-20) [Ri = 500 Ω]	
Output signal X	V	0-10 (2-10)	
Closing force	N	2000	1500
Max. stroke	mm	40	
Speed	mm/s	8	4
Max. medium temperature	$^{\circ}\text{C}$	200	
Ambient temperature	$^{\circ}\text{C}$	0 ... 55	
Storage and transport temperature	$^{\circ}\text{C}$	-40 ... +70	
Grade of enclosure		IP 54	
Weight	kg	3.8	
CE marking in accordance with standards		Low Voltage Directive (LVD) 2006/95/EC: EN 60730-1, EN 60730-2-14 EMC Directive 2004/108/EC: EN 61000-6-2, EN 61000-6-3	



Actuator for 3-Point Control

AMV 55 and AMV 56



- Load related "switch off" function that prevents overloading
- Manual operation

The actuators AMV 55 and AMV 56 are used with VF 2, VF 3 valves from DN 100 up to DN 150 diameter.

Applications

Operation of seated valves.

Compatible Valves

VF 2 Page 38
 VF 3 Page 38



Actuator

Type	Supply voltage	Code number
AMV 55	24 V AC	082H302000
AMV 55	230 V AC	082H302100
AMV 56	24 V AC	082H302300
AMV 56	230 V AC	082H302400

Accessories

Type	Code number
Additional switches (2x)	082H703700
Potentiometer (10kΩ/30 mm - for VF, VL DN 100)	082H703500
Potentiometer (10kΩ/40 mm - for VF DN 125-150)	082H703600
Potentiometer (1kΩ/30 mm - for VF, VL DN 100)	082H703800
Potentiometer (1kΩ/40 mm - for VF DN 125-150)	082H703900
Stem heater (VF, VL valves DN 100)	065Z702000
Stem heater (VF valves DN 125, 150)	065Z702200

Technical data

Type		AMV 55	AMV 56
Power supply	V	24 AC, 230 AC; ±10%	
Power consumption	VA	7	17.5
Frequency	Hz	50/60	
Control input		3-point	
Closing force	N	2000	1500
Max. stroke	mm	40	
Speed	mm/s	8	4
Max. medium temperature	°C	200	
Ambient temperature	°C	0 ... 55	
Storage and transport temperature	°C	-40 ... +70	
Grade of enclosure		IP 54	
Weight	kg	3.8	
CE marking in accordance with standards		Low Voltage Directive 73/23/EEC, EMC-Directive 2006/95/EEC: - EN 60730-1, EN 60730-2-14	

Actuators for Modulating Control

AME 85 and AME 86



Actuator

Type	Supply voltage	Code number
AME 85	24 V AC	082G145200
AME 86		082G146200

- "Self stroking" function
- Load related "switch off" function that prevents overloading
- Manual operation

The actuators AME 85 and AME 86 are used with VF 2 and VF 3 valves DN 125 and DN 150 diameter.

Accessories

Type	Code number
Stem heater for VF valves DN 125-150	065Z702100

Applications

Operation of seated valves.

Compatible Valves

VF 2	Page 38
VF 3	Page 38

Technical data		AME 85	AME 86
Power supply	V	24 AC; +10% to -15%	
Power consumption	VA	12.5	25
Frequency	Hz	50/60	
Control input Y	V	0-10 (2-10) [Ri = 50 Ω]	
	mA	0-20 (4-20) [Ri = 500 Ω]	
Output signal X	V	0-10 (2-10)	
Closing force	N	5000	
Max. stroke	mm	40	
Speed	mm/s	8	3
Max. medium temperature	°C	200	
Ambient temperature	°C	0 ... 55	
Storage and transport temperature	°C	-40 ... +70	
Grade of enclosure		IP 54	
Weight	kg	9.8	10
CE marking in accordance with standards		Low Voltage Directive (LVD) 2006/95/EC: EN 60730-1, EN 60730-2-14 EMC Directive 2004/108/EC: EN 61000-6-2, EN 61000-6-3	



Actuators for 3-point control

AMV 85 and AMV 86



- Load related "switch off" function that prevents overloading
- Manual operation

The actuators AMV 85 and AMV 86 are used with VF 2 and VF 3 valves DN 125 and DN 150 diameter.

Applications

Operation of seated valves.

Compatible Valves

VF 2 Page 38
 VF 3 Page 38



Actuator

Type	Supply voltage	Code number
AMV 85	24 V AC	082G145000
AMV 85	230 V AC	082G145100
AMV 86	24 V AC	082G146000
AMV 86	230 V AC	082G146100

Accessories

Type	For actuators	Code number
Additional switches (2x)	AMV 86 / 24 V	082H705000
	AMV 86 / 230 V	082H705100
	AMV 85 / 24 V	082H707200
	AMV 85 / 230 V	082H707100
Additional switches (2x) and potentiometer (10kΩ)	AMV 86 / 24 V	082H708100
	AMV 86 / 230 V	082H708000
	AMV 85 / 24 V	082H708300
	AMV 85 / 230 V	082H708200
Stem heater for VF valves DN 125-150		065Z702100

Technical data

Type		AMV 85	AMV 86
Power supply	V	24 AC/230 AC ; +10 to -15%	
Power consumption	VA	10.5	23
Frequency	Hz	50/60	
Control input		3-point	
Closing force	N	5000	
Max. stroke	mm	40	
Speed	mm/s	8	3
Max. medium temperature	°C	200	
Ambient temperature	°C	0 ... 55	
Storage and transport temperature	°C	-40 ... +70	
Grade of enclosure		IP 54	
Weight	kg	9.8	10
CE marking in accordance with standards		Low Voltage Directive (LVD) 2006/95/EC: EN 60730-1, EN 60730-2-14 EMC Directive 2004/108/EC: EN 61000-6-2, EN 61000-6-3	

Actuators for 3-point or modulating control

AME 855



Actuator

Type	Supply voltage	Code number
AME 855	24 V AC	082G351000
	230 V AC	082G351100

Technical data		
Type	AME 855	
Power supply	V	24 AC/230 AC
Power consumption	VA	50 (24V), 63 (230V)
Frequency	Hz	50/60
Closing force	N	15000
Max. stroke	mm	80
Speed	mm/s	2
Max. medium temperature	°C	130
Ambient temperature	°C	-10 ... 50
Protection class	II	

- 3-point or modulating control
- Easy to use manual operation (monitoring on terminal R)
- Position indication
- LED signalling
- Direct or inverse function
- Automatic adaptation of stroke to valve's end positions which reduces commissioning time
- Frost protection function
- Blockage detection
- Internal temperature control
- Selectable hysteresis
- Auto test function
- Auto pause function
- Remote reset possibility

The AME 855 actuators are used with the VF3 seated valves and are designed for use in District Heating/cooling, heating, ventilating and air conditioning systems. AME 855 actuators can be controlled by electronic controllers with modulating or 3-point control output.

Compatible Valves

VF 3 (DN200 to DN 300)Page 38



2-Way Seated Control Valve VFM2



- Logarithmic control characteristic
- Control ratio - 100:1
- Pressure relieved design
- Temperature range (C): -10...150
- Flange connection

2-way seated control valve applicable for heating, district heating and district cooling systems.

Compatible Actuators

AMV 655.....	Page 49
AME 655.....	Page 49
AMV 658.....	Page 49
AME 658.....	Page 49

DN	k_{vs} (m ³ /h)	PN	Δp_s ²⁾ (bar)	Δp_{max} (bar) ¹⁾ for AMV/E 65x	Code number
65	63	16	16	8	065B350000
80	100				065B350100
100	160				065B350200
125	250		065B350300		
150	400		065B350400		
200	630	10	10	4	065B350500
250	900				065B350600

1) Δp_{max} is maximum permissible differential pressure across the valve referred for the whole actuating range of motorised valve (a function of the actuator's performance).

2) Δp_s is maximum permissible closing differential pressure applied in fully closed position of the valve, at which the valve will seal tightly (close off pressure).





Actuators

AMV 655 and AMV 658 for 3-Point Control

AME 655 and AME 658 for Modulating Control

Actuator

Type	Supply voltage	Code number
AMV 655	24V	082G344000
	230V	082G344100
AMV 658 SD	24V	082G344400
	230V	082G344500
AMV 658 SU	24V	082G344600
	230V	082G344700

Accessories

Type	Code number
Adapter to fit actuator to VFG DN15-65 valves	065B352500
Adapter to fit actuator to VFG DN80-125 valves	065B352600
Adapter to fit actuator to VFG DN150-250 valves	065B352700

- Manual operation mechanical and/or electrical
- Position indication via LED signal
- Inverse function
- Pulse output signal
- Thermic and overload protection
- Precise regulation and fast response on 3-point signal (0.04s)

AMV electrical actuators provide three point control when fitted in conjunction with VFM2 valves.

Compatible Valves

VFM2Page 48

Actuator

Type	Supply voltage	Code number
AME 655	24V	082G344200
	230V	082G344300
AME 658 SD	24V	082G344800
	230V	082G344900
AME 658 SU	24V	082G345000
	230V	082G345100

Accessories

Type	Code number
Adapter to fit actuator to VFG DN15-65 valves	065B352500
Adapter to fit actuator to VFG DN80-125 valves	065B352600
Adapter to fit actuator to VFG DN150-250 valves	065B352700

- Manual operation mechanical and/or electrical
- Position indication via LED signal
- Selectable speed (2 or 6 s/mm)
- Self-stroking
- 3 point or modulation control setting
- Precise regulation and fast response on 3-point signal (0.04s)

AME actuators provide modulating control when fitted in conjunction with VFM2 valves.

Compatible Valves

VFM2Page 48

Brass Rotary Valves

HRB 3 and HRB 4



HRB rotary valves are used together with the actuators AMB 162 (also AMB 182 could be used as well if special speed is required).

The valves are used for controlling flow temperature in heating systems in which a certain leakage can be accepted and in which a defined control characteristic is not required.

Applications

Water based heating and cooling applications. 3-port valves can be placed in diverting and mixing function whereas 4-port version function is double mixing.

Compatible Actuators

AMB162 Page 52
 AMB182 Page 52

Type	DN	k _{vs} (m ³ /h)	PN	Connection	Code number		
					HRB 3	HRB 4	
HRB 3 HRB 4	15	0.4	10	Rp ½"	065Z039900	-	
		0.63			065Z040000		
		1.0			065Z040100		
		1.63			065Z040200		
		2.5			065Z040300		065Z041100
		4.0			065Z039800		
	20	2.5		065Z039700	Rp ¾"	065Z040400	065Z041200
		4.0		065Z040500		065Z041300	
		6.3		065Z040600		-	
		6.3		065Z040700		065Z041400	
	25	10		Rp 1"	065Z040800	065Z041500	
		16			065Z040900	065Z041600	
	40	25		Rp 1½"	065Z041000	065Z041700	
	50	40		Rp 2"			

Technical data							
Nominal diameter	DN	15	20	25	32	40	50
Control characteristic		S characteristic					
Leakage	HRB 3	Diverting: max. 0.02% of flow / Mixing: max. 0.05% of flow					
	HRB 4	Max. 1.0% of k _{vs}					
Nominal pressure	PN	10					
Max. closing pressure	bar	Diverting: 2 / Mixing: 1					
Torque at PN	Nm	5					
Medium		Circulation water / glycolic water up to 50%					
Medium pH		Min. 7, Max. 10					
Medium temperature	°C	2 ... 110					
Connections		Internal thread ISO 7/1					
Materials							
Valve body and slide shoe		CuZn36Pb2As (Brass DZR, CW 602N)					
Stuffing box		CuZn36Pb2As (Brass DZR, CW 602N)					
Stuffing box sealing		EPDM					



Cast Iron Rotary Valves

HRE 3 and HRE 4



Type	DN (mm)	k _{vs} (m ³ /h)	PN	Connection	Code number	
					HRE 3	HRE 4
HRE 3 HRE 4	20	6.3	6	Rp 3/4"	065Z041800	065Z042300
	25	10		Rp 1"	065Z041900	065Z042400
	32	16		Rp 1 1/4"	065Z042000	065Z042500
	40	25		Rp 1 1/2"	065Z042100	065Z042600
	50	40		Rp 2"	065Z042200	065Z042700

HRE rotary valves are used together with the actuators AMB 162 (also AMB 182 could be used as well if special speed is required).

The valves are used for controlling flow temperature in heating systems in which a certain leakage can be accepted and in which a defined control characteristic is not required.

Technical data						
Nominal diameter	DN	20	25	32	40	50
Control characteristic		S characteristic				
Leakage	HRE 3	Diverting: max. 0.05% of k _{vs} / Mixing: max. 1.0% of k _{vs}				
	HRE 4	Max. 1.5% k _{vs}				
Nominal pressure	PN	6				
Max. closing pressure	bar	1				
Torque at PN	Nm	5				
Medium		Circulation water / glycolic water up to 50%				
Medium pH		Min. 7, Max. 10				
Medium temperature	°C	2 ... 110				
Connections		Internal thread ISO 7/1				
Materials						
Valve body		Grey cast iron EN-GJL-250(GG25)				
Slide shoe		CuZn36Pb2As (Brass DZR, CW 602N)				
Stuffing box sealing		EPDM				

Applications

Water based heating and cooling applications. 3-port valves can be placed in diverting and mixing function whereas 4-port version function is double mixing.

Compatible Actuators

AMB162.....Page 52
AMB182.....Page 52



Rotary Actuators

AMB 162 and AMB 182



- Position indicator
- Manual operation

AMB 162 and AMB 182 actuators are used for temperature control in central heating systems together with 3-way and 4-way rotary valves of the types HRB and HRE.

The actuators are applicable with:

- Controllers with 3-point outlet
- Controllers with voltage or current output

Applications

Operation of rotary valves

Compatible Valves

HRB3.....	Page 50
HRB4.....	Page 50
HRE3.....	Page 51
HRE4.....	Page 51

Type	Torque (Nm)	Control signal	Speed (s/90°C)	Supply voltage (v)	Remark	Code number
AMB 162	5	3-point	120	24	-	082H021300
			120		AS	082H021800
			60	230	-	082H022200
			120		-	082H022300
			480		-	082H022400
			120		AS	082H022800
	Modulating	140	24	-	082H023000	
AMB 182	10	3-point	60	24	-	082H023100
			60	230	-	082H023200
			240	24	-	082H023400
	15		240	230	-	082H023800
			240	230	AS	082H024000
			140	24	-	082H024100

* Actuator with built-in auxiliary signal switch

Technical data		
Power supply	V	24 AC/DC or 230 AC
Power consumption	VA	AMB 162: 2,5
		AMB 182: 3,5
Frequency	Hz	50/60
Control input		3-point
		0-10 V (2-10 V)
Operating torque	Nm	5, 10 or 15
Rotation angle	°	90
Ambient temperature	°C	0 ... 50
Storage and transport temperature	°C	-10 ... +80
Protection Class		II
Grade of enclosure		IP 42
Weight	kg	AMB 162: 0.46
		AMB 182: 0.54
CE marking in accordance with standards		Low Voltage Directive (LVD) 2006/95/EC: EN 60730-1, EN 60730-2-14 EMC Directive 2004/108/EC: EN 61000-6-2, EN 61000-6-3



Motorised Zone Valves AMZ 112, 113 and 122



AMZ 112, 2-port ball valve with actuator

DN	k _{vs} (m ³ /h)	Connection	max. Δp valve	Code number	
				24V	230V
15	17	Cu-Cu 22	6 bar	082G542600	-
20	41	Cu-Cu 22		082G542700	-
15	17	Rp ½"		082G540000	082G540600
20	41	Rp ¾"		082G540100	082G540700
25	70	Rp 1"		082G540200	082G540800
32	121	Rp 1¼"		082G540300	082G540900
40	200	RP 1 ½"		082G540400	082G541000
50	292	Rp 2		082G540500	082G541100

- Indication of actual valve position
- LED indication of turning direction
- Manual valve turning mode enabled by a permanent clutch
- No damage in case of valve blocking
- Silent and reliable operation
- Maintenance free
- Integrated auxiliary switch
- LED indication of activated auxiliary switch

AMZ 113, 3-port ball valve with actuator

DN	k _{vs} (m ³ /h)	Connection	max. Δp valve	Code number	
				24V	230V
15	17	Rp ½"	6 bar	082G541200	082G541800
20	41	Rp ¾"		082G541300	082G541900
25	70	Rp 1"		082G541400	082G542000
32	121	Rp 1¼"		082G541500	082G542100

AMZ motorised control valves are primarily designed for domestic and commercial central heating applications, priority control in domestic hot water application, solar energy application and priority control of boiler and solid fuel installations.

AMZ 122, Tamperproof 2-port ball valve with actuator

DN	k _{vs} (m ³ /h)	Connection	max. Δp valve	Code number (230V)
15	17	Rp ½"	6 bar	082G548000
25	70	Rp 1"		082G543200
32	121	Rp 1¼"		082G543300



Type		AMZ 112	AMZ 113
Power supply	V	24V AC / 230V AC	
Power consumption	VA	3,5 (<0.2W stand by)	
Frequency	Hz	50/60	
Control input		On/off	
Rotation angle	s/90°	30	60
Max. medium temperature	°C	110	
Ambient temperature	°C	0 ... 50	
Storage and transport temperature	°C	-10 ... +80	
Protection Class		II	
Grade of enclosure		IP 42	

DN	Valve - AMZ 112						Valve - AMZ 113			
	15	20	25	32	40	50	15	20	25	32
Nominal pressure	16			25			40			
Flow (K _v)	17	41	70	121	200	292	17	41	70	121
Medium temperature	-20 ... 130									
Medium	Drinking water, water, glycol ≤ 50%, air, non aggressive fluids									
Max. operating torque	1.35	1.85	2.80	3.30	4.00	4.75	2.7	3.7	5.6	6.6
Max. operating ΔP	6									
Connection	Internal thread Rp ISO 7/1									
Materials										
Body	CW 617 N UNI EN 12165									
Ball	CW 617 N UNI EN 12164									
Anti-friction ring	PTFE									

Butterfly Valves

VFY-WA



- Butterfly valve in 25mm-300mm complete with 24V or 230V On/Off actuators
- Comes built with actuator already connected to the valve
- Wafer style connection with 4 centring lugs
- Complete with position indicator and manual adjustment dial
- Small in build for installation in a confined space
- 30 second opening and closing speed
- Spare valves and actuators available

Technical Data	
Power Supply	24V and 230V
Actuator speed	30 sec/90°
Actuator working temperature (ambient)	minimum -10°C, maximum +50°C
Valves DN	DN 25 - DN 300
Leakage rate	Acc. to PED 97/23/CE, EN 12266-1, Rate A*
Valves pressure rating	16 bar from DN 32 - DN300 10 bar for DN 25
Medium	Chilled water 35% Glycol, Hot Water
Medium temperature	2 - 120°C
Protection code	IP 65 (DN 25 - DN 125), IP 66 (DN 150, 200), IP 67 (DN 250, 300)
Liner	EPDM
Material: Valve body	Cast iron EN GJL 250 (DIN GG25)
Flange:	Acc. to ISO 5211 and NF E 29-402 standards
Flange connection:	Between counter flanges acc. EN 1092-1

VFY-WA 230V

Code No.	Type	DN (mm)	Kvs (m ³ /h)	Nominal Pressure	Opening time (s)	Weight (kg)
082G735000	VFY - WA	25	40	PN10	12	3.2
082G735100		32/40	62			3.3
082G740000		50	79			3.4
082G740100		65	174			4.5
082G740200		80	275	PN16	7	4.6
082G740300		100	496		12	6.4
082G740400		125	883			8.5
082G740500		150	1212			10.5
082G740600		200	2500	60		19.4
082G740700		250	3948		26.8	
082G740800		300	5635		38	47.5
082G740900		350	8520	54		

VFY-WA 24V

Code No.	Type	DN (mm)	Kvs (m ³ /h)	Nominal Pressure	Opening time (s)	Weight (kg)
082G736100	VFY - WA	25	49	PN10	12	3.2
082G736200		32/40	62			3.3
082G736300		50	79			3.4
082G736400		65	173			4.5
082G736500		80	275	PN16	7	4.6
082G736600		100	496		12	6.4
082G736700		125	883			8.5
082G736800		150	1212			10.5
082G736900		200	2500	60		19.4
082G737000		250	3948		26.8	

Electrical Actuators for Air Dampers

AMD



Motorised Control Valves

Type	Torque (Nm)	Max. Damper Area (m ²)	Control Signal Type	Supply Voltage (V)	Spring Return	Auxiliary Switches	Code number (24V)	Code number (230V)
AMD 113	3	0.6	ON/OFF	24V / 230V	•		082H113600	082H113800
AMD 113 AS			24V / 230V	•	•	082H113700	082H113900	
AMD 123			analogue 0...10V	24V	•		082H114000	
AMD 123 AS					•	•	082H114100	
AMD 213	5	1	ON/OFF	24V / 230V	•		082H114200	082H114400
AMD 213 AS			24V / 230V	•	•	082H114300	082H114500	
AMD 223			analogue 0...10V	24V	•		082H114600	
AMD 223 AS					•	•	082H114700	
AMD 210	5	1	ON/OFF	24V / 230V			082H110000	082H110200
AMD 210 AS			24V / 230V		•	082H110100	082H110300	
AMD 220			analogue 0...10V	24V			082H110400	
AMD 220 AS					•	082H110500		
AMD 310	8	1.6	ON/OFF	24V / 230V			082H110600	082H110800
AMD 310 AS			24V / 230V		•	082H110700	082H110900	
AMD 420	10	2	analogue 0...10V	24V			082H111000	
AMD 420 AS						•	082H111100	
AMD 413	10	2	ON/OFF	24V / 230V	•		082H114800	082H115000
AMD 413 AS			24V / 230V	•	•	082H114900	082H115100	
AMD 423			analogue 0...10V	24V	•		082H115200	
AMD 423 AS					•	•	082H115300	
AMD 510	15	3	ON/OFF	24V / 230V			082H111200	082H111400
AMD 510 AS			24V / 230V		•	082H111300	082H111500	
AMD 520			analogue 0...10V	24V			082H111600	
AMD 520 AS					•	082H111700		
AMD 613	20	3	ON/OFF	24V / 230V	•		082H115400	082H115600
AMD 613 AS			24V / 230V	•	•	082H115500	082H115700	
AMD 623			analogue 0...10V	24V	•		082H115800	
AMD 623 AS					•	•	082H115900	
AMD 610	20	4	ON/OFF	24V / 230V			082H111800	082H112000
AMD 610 AS			24V / 230V		•	082H119000	082H112100	
AMD 620			analogue 0...10V	24V			082H112200	
AMD 620 AS					•	082H112300		
AMD 710	30	6	ON/OFF	24V / 230V			082H112400	082H112600
AMD 710 AS			24V / 230V		•	082H112500	082H112700	
AMD 720			analogue 0...10V	24V			082H112800	
AMD 720 AS					•	082H112900		
AMD 810	40	8	ON/OFF	24V / 230V			082H113000	082H113200
AMD 810 AS			24V / 230V		•	082H113100	082H113300	
AMD 820			analogue 0...10V	24V			082H113400	
AMD 820 AS					•	082H113500		

AMD (AS) actuators are available as either 2/3 point control or modulating control versions. They all have spring return function and are for use in heating, ventilation and air conditioning applications (HVAC)

The actuators are used for the regulation of air dampers with a 90° angle of rotation. The AS versions include 2 built-in auxiliary switches.



Hydronic Balancing Valves

If you are dedicated to establish indoor climate solutions that provide optimal air quality, comfortable living and/or work conditions and maximum energy efficiency, then Danfoss is your ideal partner.

You already know that the most efficient heating or cooling installations can only be realised by ensuring optimal hydronic balance and perfect temperature control. We have many years of experience and a complete range of products in this area.

We supply high quality products for innovative, energy saving and easy to use solutions.

In this section we present a basic overview of our many products for different applications. Each has its own special features and benefits to make your daily work easier, faster or better.



Contents

Why Use Balancing Valves.....	58
Balancing Valve Selection Guide - Heating Systems.....	60
Balancing Valve Selection Guide - Cooling Systems.....	62
MSV-O Fixed Orifice Commissioning Valve.....	64
MSV-BD Variable Orifice Commissioning Valve.....	65
MSV-F2 Variable Orifice Commissioning Valve.....	66
Differential Pressure Control Valves.....	67
ASV-PV Differential Pressure Control Valve.....	68
AVPL Differential Pressure Controller.....	69
AVP Self-Acting Differential Pressure Control Valve.....	70
AFP Self-Acting Differential Pressure Controller.....	71
AB-QM Sizing Chart.....	72
AB-QM Pressure Independent Balancing and Control Valve.....	73
AB-QM Actuator Selection Chart.....	74
NovoCon.....	76
AB-QM Actuators - TWA-Z and ABNM.....	78
AME/AMV 110/120NL, AME 110NLX, AMI 140 Actuators.....	79
FEV-Z Climate Sensor.....	80
AB-PM Combined Automatic Balancing Valve.....	81
AME 55/85/435 QM Actuators.....	82
Differential Pressure Relief Valves.....	83
AVDO Automatic By-Pass Valve.....	84
AVDA Pressure Relief Valves.....	85
AVPA Differential Pressure Relief Valve.....	86
AFPA Combination Pressure Relief Valve.....	87
MTCV Thermostat Circulation Valve.....	88
PFM100 Measuring Equipment.....	89

Why use Balancing Valves?



MSV-O

There are many reasons to use automatic or manual balancing valves. Some symptoms of badly balanced heating/cooling systems are:

- Noise Problems
- Insufficient Capacity
- Poor/inaccurate control
- Long start-up times
- Energy wastage

Balancing valves can provide a solution to all of these problems providing an economical and cost effective solution to common hydronic problems.

There are two main types of system, each of them present differing challenges when it comes to balancing the system:

Constant Flow System

Involves the use of a 3 port valve and a bypass, to maintain the flow around a system when there is no demand from the terminal units. In these systems, the overall flow remains constant.

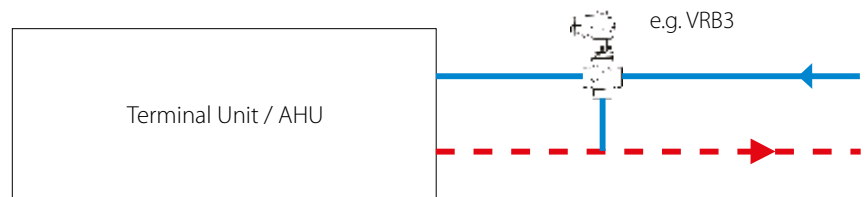

Variable Flow System

Involves the use of 2 port valves to shut off the flow to the terminal units when there is no demand. In these systems the overall flow varies depending on demand for heating or cooling.

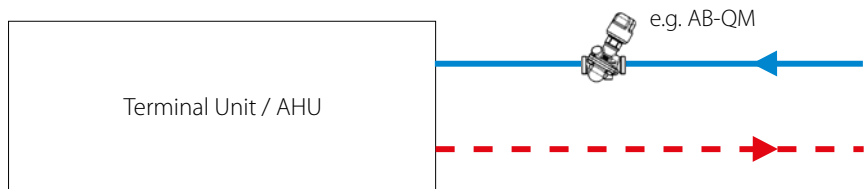

MSV-BD



MSV-F2

Solutions for Constant Flow Systems

Danfoss offers a range of solutions using both manual and automatic balancing valves, using a combination of the LENO™ MSV-O and MSV-BD valves can provide ease of installation and balancing. In the MSV-O valve, the flow is measured over a fixed venturi orifice, providing very fast and accurate measurement. The MSV-O and MSV-F2 valves can then be adjusted to provide the required flow rates.

In order to reduce installation and commissioning costs, the AB-QM valve can be used to good effect as a constant flow regulator (CFR). The setting of the flow is simply a case of calculating the required flow, selecting a valve which covers the flow rate you require and setting the valve (desired flow/max flow x 100 = setting). This means no commissioning or measurement is needed, however the AB-QM valves do have nipples for differential pressure recording and verification purposes.

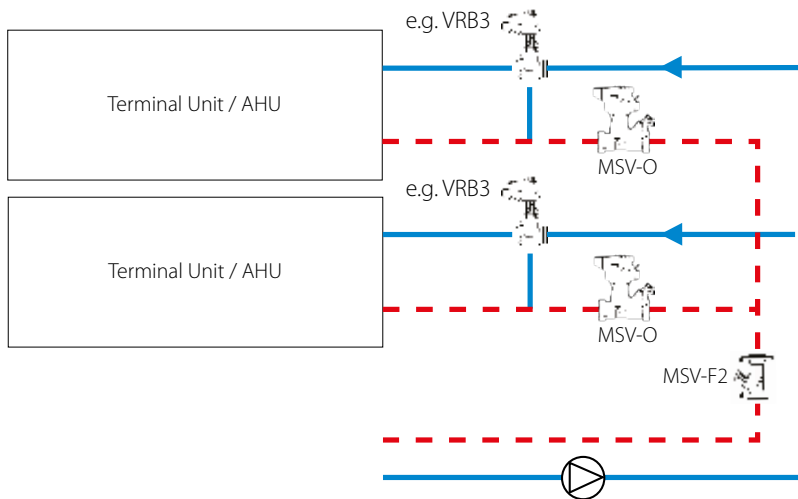

ASV-PV



ASV-I

Solutions for Variable Flow Systems

Variable flow systems are perfectly suited to automatic balancing valve solutions (ASV), or by using the AB-QM, combined with an actuator (see pages 46 to 49) to act as a flow regulator and control valve in one. As with the constant flow system, when using an AB-QM the need for additional valves is removed, and setting up for a required flow is simple using the built in scale on the valve.

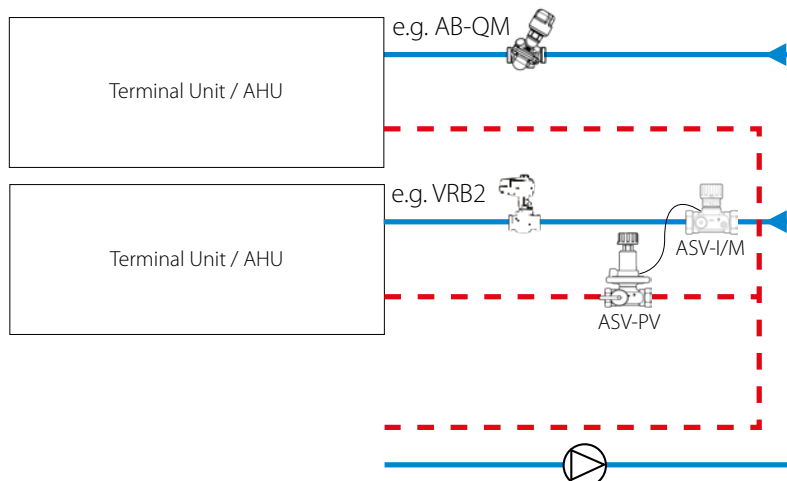

AB-QM

Balancing Valve Selection Guide

Heating Systems

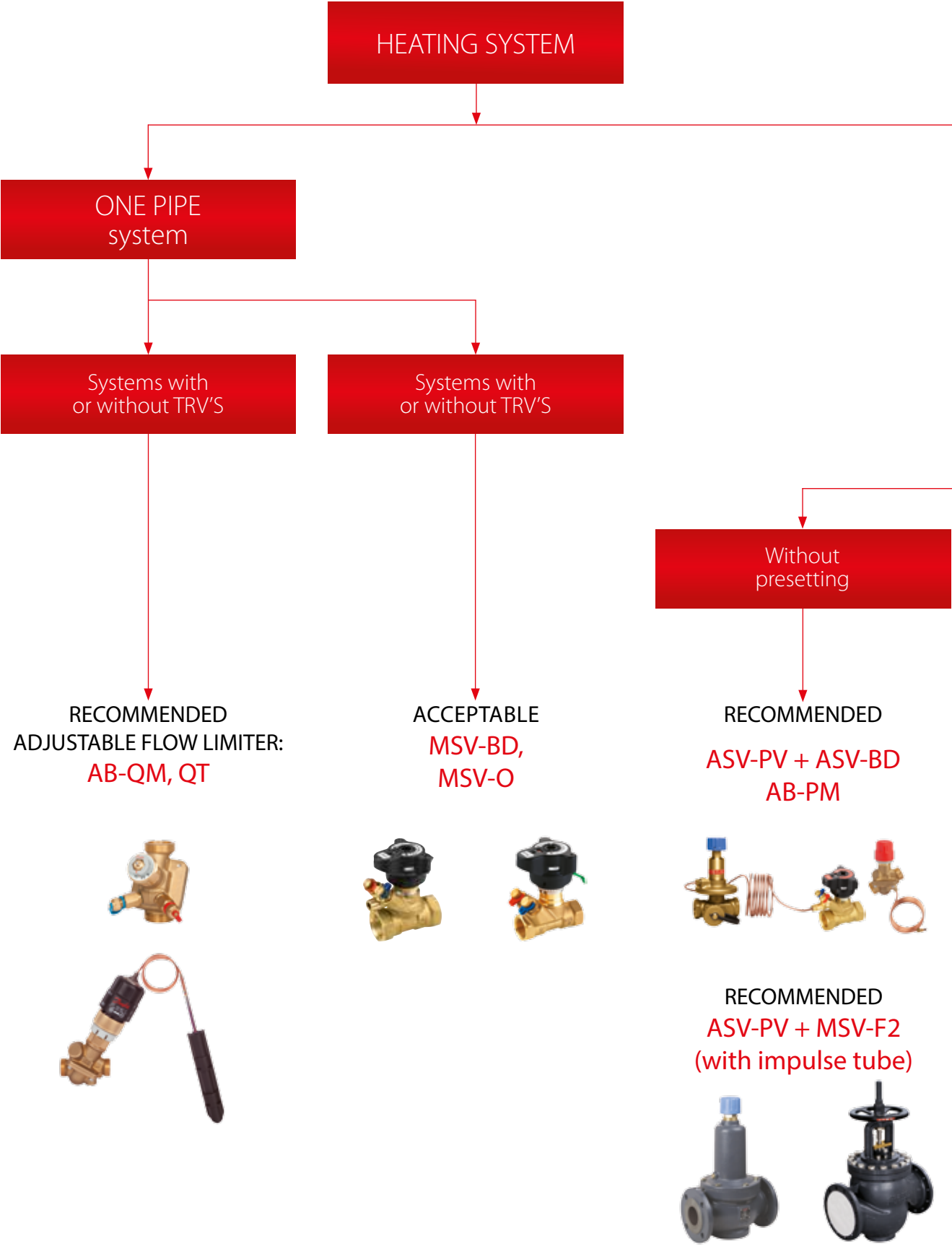

Balancing Valve Selection Guide

Heating Systems

DHW

TWO PIPE
system

Systems with
TRV'S

Systems without
TRV'S

With
presetting

Upgrade to TRV'S
not possible

Domestic hot water
circulation system

RECOMMENDED

ASV-PV + ASV-M
AB-PM



RECOMMENDED

MSV-BD/O



RECOMMENDED

MTCV



RECOMMENDED

ASV-PV + MSV-F2
(with impulse tube)



Balancing Valve Selection Guide

Cooling Systems

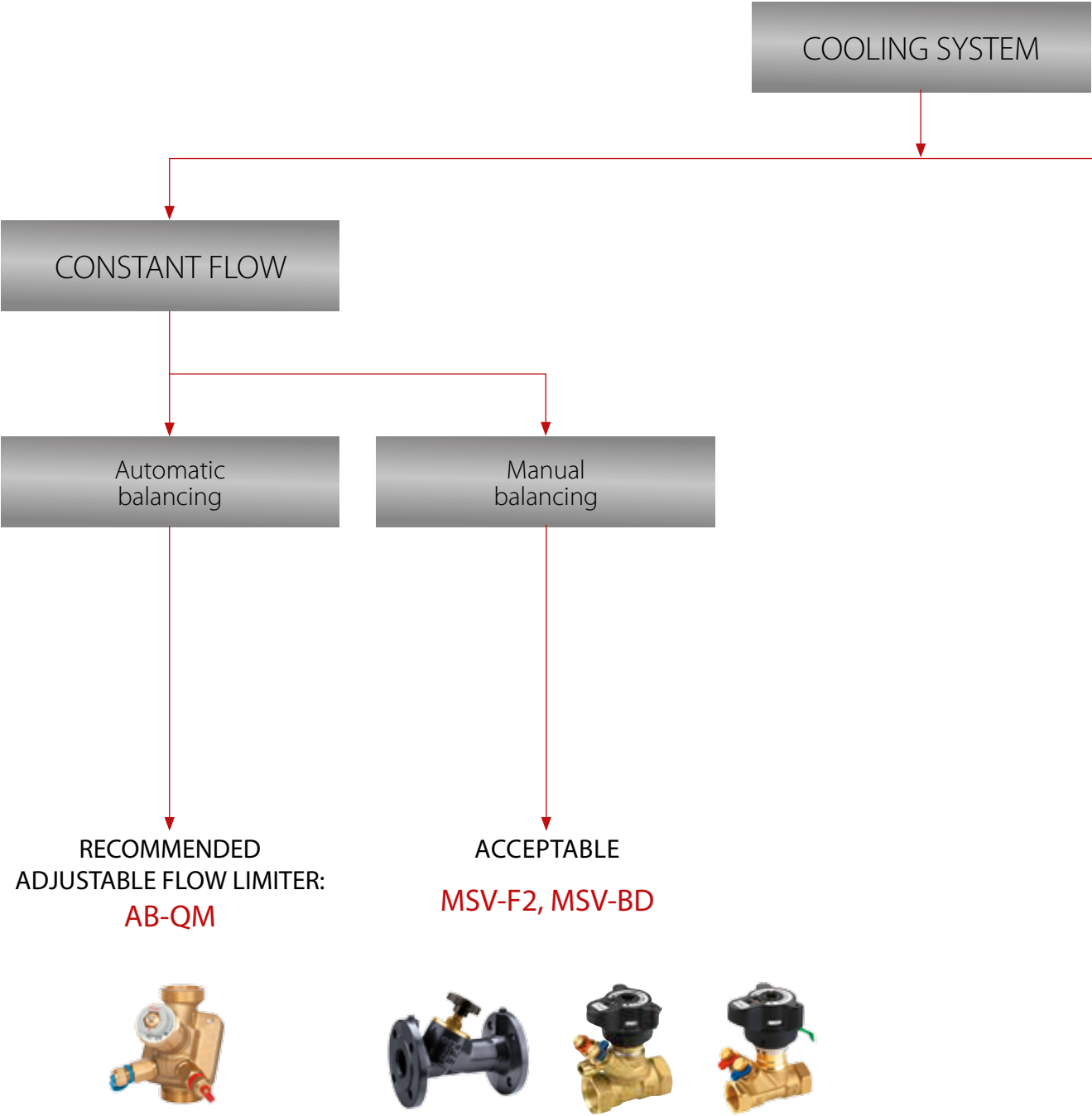

Balancing Valve Selection Guide

Cooling Systems

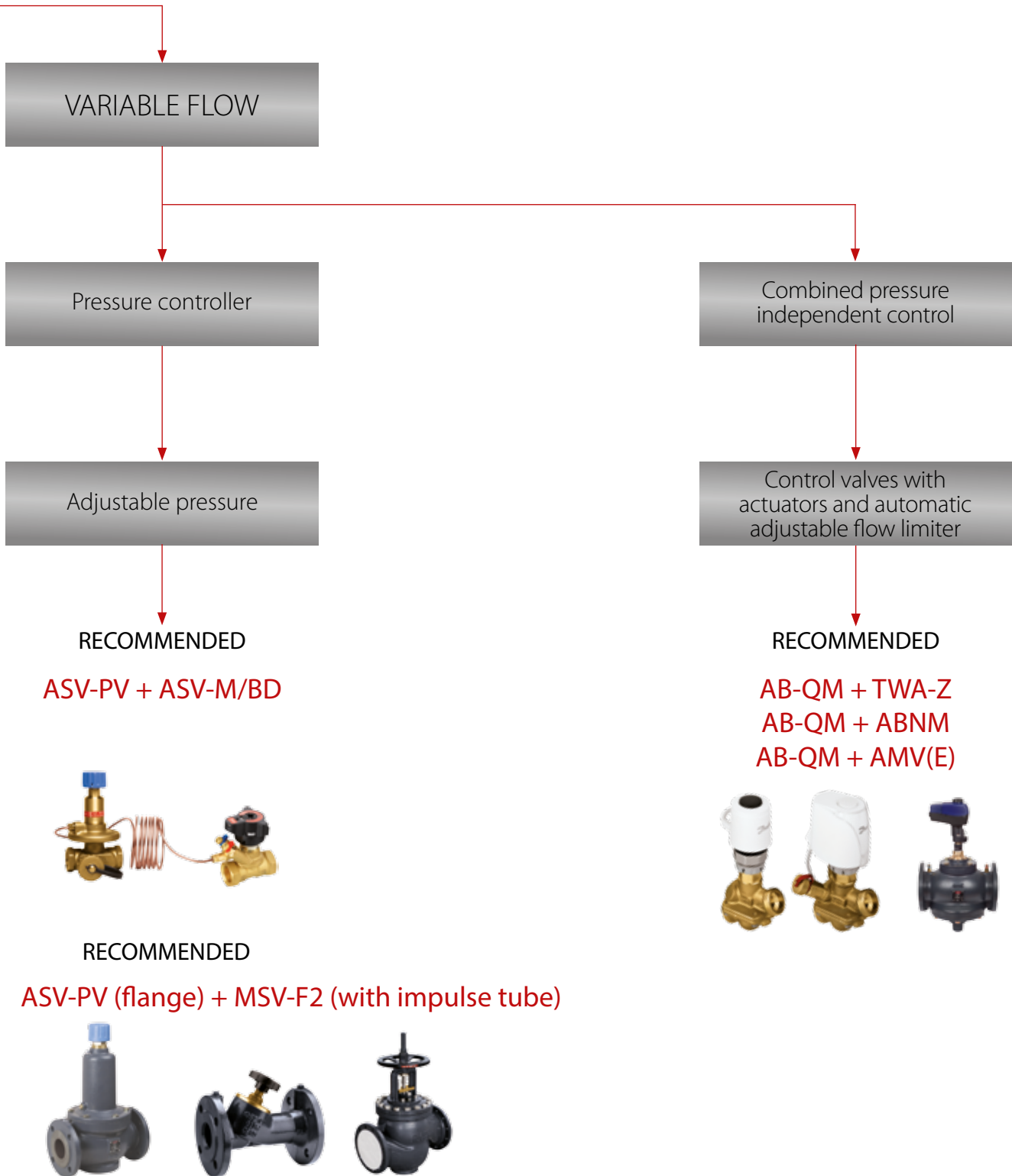

Fixed Orifice Commissioning Valve MSV-O



- Fixed venturi orifice
- Removable hand wheel for easy mounting
- Numeric presetting scale, visible from more angles
- Easy locking of presetting
- Built-in measuring nipples for 3mm needles
- Open-Closed colour indicator
- Measuring accuracy is 8% up to 25% of maximum setting
- Internal thread
- Sizes DN15LF - DN50
- All valves are DZR Brass

MSV-O is a new generation of manual valves for balancing flow in heating, cooling and domestic hot water systems. These combined presetting and shut off valves have a range of unique features and may be mounted in flow or return.

It is recommended to use MSV-O for balancing and shut-off in constant flow systems, i.e. in front of boilers, flat stations or heat pumps in one-family houses.



MSV-O has a fixed venturi orifice in the valve body with constant kvs-value. This feature makes it possible to read flow on the measuring device, without typing in presetting. This feature saves time for commissioning for each valve installed.

MSV-O valve with internal thread					
Type	Material	Size	Kvs (m ³ /h)	Connection	Code No.
	DZR Brass	DN 15 LF	0.63	Rp 1/2"	003Z402000
		DN 15	2.8	Rp 1/2"	003Z402100
		DN 20	5.7	Rp 3/4"	003Z402200
		DN 25	9.7	Rp 1"	003Z402300
		DN 32	16.6	Rp 1 1/4"	003Z402400
		DN 40	25.4	Rp 1 1/2"	003Z402500
		DN 50	37.9	Rp 2"	003Z402600

Accessories	
Type	Code No.
Standard measuring nipples, 2pcs.	003Z466200
Extended measuring nipples, 60mm, 2 pcs.	003Z465700
Operating handle	003Z465200
Identification tag and strips, 10 pcs.	003Z466000

Applications

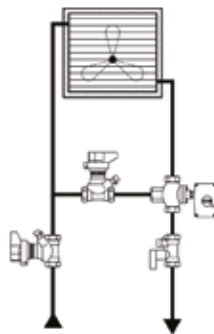

- Air handling unit**
- For constant flow
 - For balancing
 - Shut-off function for service/repair

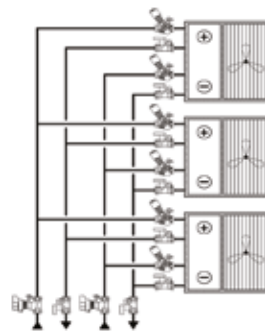

- Fan coils**
- For flow verification
 - Shut-off function for service/repair

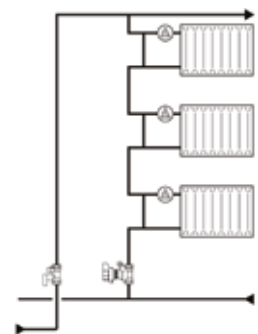

- Radiators**
- For flow verification
 - Shut-off function for service/repair

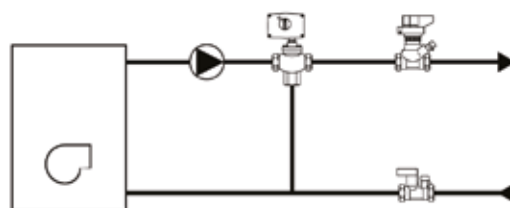

- Boiler, flat station or heat pump in 1-family houses.**
- For balancing.
 - Shut-off function for service/repair.

Variable Orifice Commissioning Valve MSV-BD



MSV-BD

MSV-BD valve with internal thread					
Type	Material	Size	Kvs (m ³ /h)	Connection	Code No.
	DZR Brass	DN 15 LF	2.5	Rp 1/2"	003Z400000
		DN 15	3.0	Rp 1/2"	003Z400100
		DN 20	6.0	Rp 3/4"	003Z400200
		DN 25	9.5	Rp 1"	003Z400300
		DN 32	18	Rp 1 1/4"	003Z400400
		DN 40	26	Rp 1 1/2"	003Z400500
		DN 50	40	Rp 2"	003Z400600

- Removable hand wheel for easy mounting
- 360° rotating measuring station for convenient measuring and draining
- Numeric presetting scale, visible from more angles
- Easy locking of presetting
- Built-in measuring nipples for 3mm needles
- Built-in drain cock with separate flow/return draining
- Open-Closed colour indicator
- Measuring accuracy is 8% up to 25% of maximum setting
- Internal thread
- Sizes DN15LF - DN50
- All valves are DZR Brass

Setting and Locking

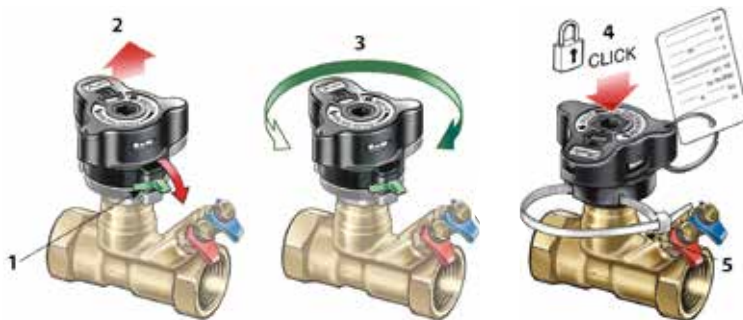

The valve has a built-in presetting feature for accurate flow ratings. Setting the required flow is made in 5 steps:

1. Release the lock using the green lever.
2. The handle pops up automatically.
3. The calculated value can now be set.
4. The setting is locked when the handle is pressed to click.
5. Seal - the setting can be protected by using a strip as shown.

Shut-Off

In order to shut-off the valve the handle must be pressed down.

The shut-off function features a ball valve, which only requires a 90 degree turn to shut the valve completely.

An indicator window shows the actual setting:

- red = closed
- white = open



MSV-BD is a new generation of manual valves for balancing flow in heating, cooling and domestic hot water systems. These combined presetting and shut off valves have a range of unique features.

It is recommended to use MSV-BD in constant flow systems. The valve may be mounted in flow or return.

DN 15 and 20 valves are available with internal or external thread. Other dimensions with internal thread.

Variable Orifice Commissioning Valve MSV-F2



- Available in sizes from DN15 – DN400
- Easy pre-setting – digital display
- Stroke limiter and non-rising handwheel for all versions
- Lockable handwheel
- G ¼ thread for various measuring nipples
- Fast and precise flow measurement using measuring orifices together with valve

The MSV-F2 is the second generation of flanged manual balancing valves from Danfoss. The MSV-F2 can be used in numerous HVAC applications such as Air Handling Units (AHUs), fan coil systems, boiler stations etc.

The MSV-F2 is compact by design, with excellent flow characteristics making it an ideal valve for almost any situation where a larger sized manual balancing valve is needed. It is made of cast iron (GG25 for PN16 versions and GGG40.3 for PN25 versions) and operates within the temperature range of -10 to 130°C (up to 150°C for PN25 versions).

All MSV-F2 valves have flow limitation via a built in stroke limiter and enable a constant pressure drop in constant flow systems.

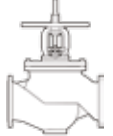
MSV-F2 valves - PN16	DN ¹⁾ mm	Kvs m ³ /h	Tmax °C	PN Bar	Code No. (with measuring nipples)
	15	3.1	130	16	003Z108500
	20	6.3			003Z108600
	25	9.0			003Z108700
	32	15.5			003Z108800
	40	32.3			003Z108900
	50	53.8			003Z106100
	65	93.4			003Z106200
	80	122.3			003Z106300
	100	200.0			003Z106400
	125	304.4			003Z106500
	150	400.8			003Z106600
	200	685.6			003Z106700
	250	952.3			003Z106800
	300	1380.2			003Z106900
	350	2046.1			003Z109000
	400	2584.6			003Z109100

1) Flange valves dimension DN 15-40, 350 and 400 available on request

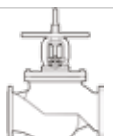
MSV-F2 valves - PN25	DN ¹⁾ mm	Kvs m ³ /h	Tmax °C	PN Bar	Code No. (with measuring nipples)
	15	3.1	150	25	003Z109200
	20	6.3			003Z109300
	25	9.0			003Z109400
	32	15.5			003Z109500
	40	32.3			003Z109600
	50	53.8			003Z107000
	65	93.4			003Z107100
	80	122.3			003Z107200
	100	200.0			003Z107300
	125	304.4			003Z107400
	150	400.8			003Z107500
	200	685.6			003Z107600
	250	952.3			003Z107700
	300	1380.2			003Z107800
	350	2046.1			003Z109700
	400	2584.6			003Z109800

Accessories

Type	Code No.	Type	Code No.
Needle nipple, 2 pcs.	003Z010400	Hand-wheel	DN 15-50 003Z017900
Extension of measuring nipple 45mm, 2 pcs	003Z010300		DN 65-150 003Z018000
Extension of measuring nipple 80mm, 2 pcs	003Z010500		DN 200 003Z018100
			DN 250-300 003Z018200
			DN 350 - 400 003Z018300

Differential Pressure Control Valves

Hydronic balancing of the district heating network provided by the self-acting controllers through flow and differential pressure ensures adequate heating supply to all subscriber stations, reduces flow and heat loss in the district heating network and increases pump performance.

Self-acting controls maintain constant differential pressure (Δp) across the control valves. This ensures the adequate pressure conditions assumed at control valves sizing and enables accurate temperature control and low return temperature, as well as prolonging the life of the control components.

Low differential pressure (Δp) across the control valves provided by Danfoss self-acting controllers prevents cavitation and reduces noise emission in the district heating system.

To achieve optimum operational conditions for the district heating system, it is very important to provide the system with hydronic balancing.

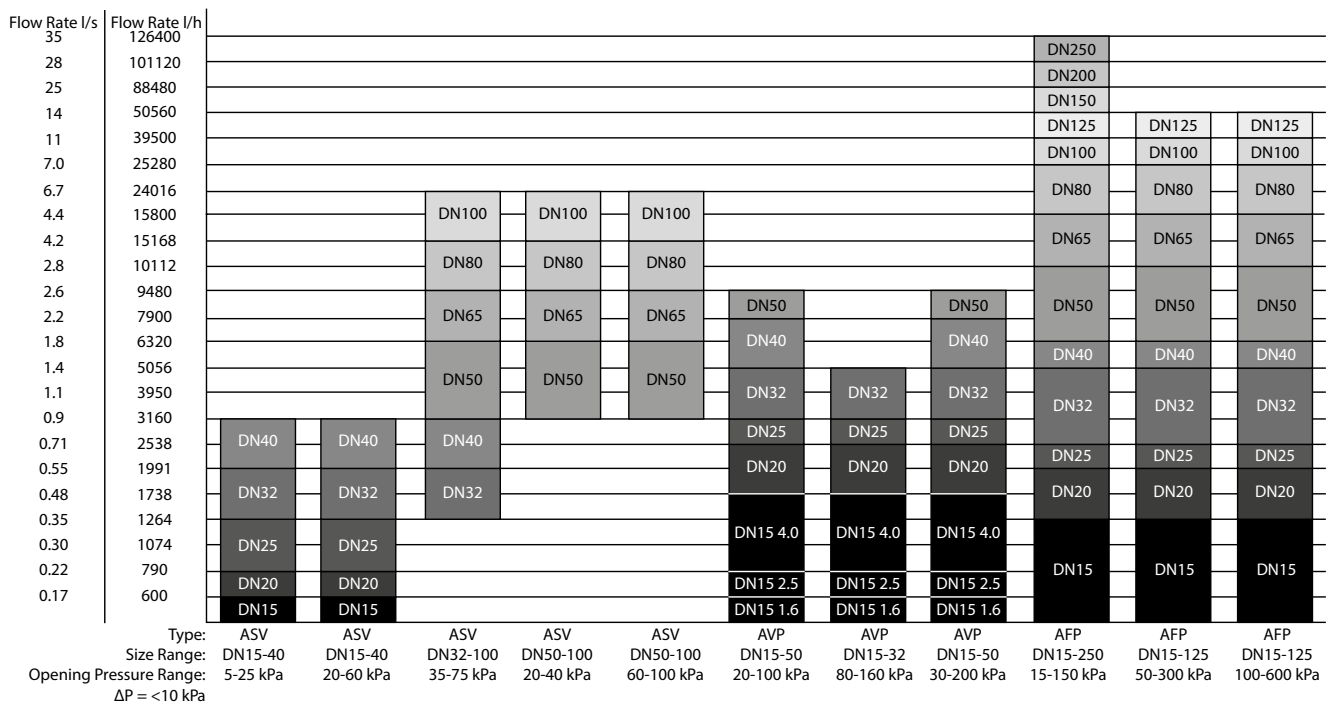

This chart is for guidance only. Any selections must be checked with a Danfoss representative before a final selection can be made.

An assumed maximum pressure loss, across the valve, of 10kPa has been applied. Higher flow ranges can be achieved by increasing the differential pressure across the valve. To select, take your required design flow rate. Find the flow points it falls between on the flow axis, draw a line horizontally. The valve sizes on the line are acceptable sizes to select. The circuit pressure is the pressure from the impulse tube on the flow to the inlet on the differential pressure control valve on the return. Please ensure you select a valve with a suitable circuit pressure for your application. The DPCV should be installed on the return. Some valves have flow mounting versions which are available on request. Consult Danfoss for guidance on installation.

Differential Pressure Control Valve

ASV-PV and ASV-BD/ASV-M





- Maintains differential pressure across risers
- ASV-PV valves are settable in different ranges:
 - 5-25 kPa setting is mostly used for radiator applications
 - 20-60 kPa setting is used for radiator, fan coil, chilled beam and flat station applications
 - 35-75 kPa setting is used for flat station and fan coil, chilled beam applications
 - 60-100 kPa setting is used for large terminal unit applications (air handling units, fan coils etc.)
- Shut-off function
- An adapted membrane for every valve dimension which provides constant performance
- Low noise emission

ASV-PV can control the differential pressure in several ranges if different pressure is needed. ASV valves in dimensions DN 15-40 are supplied with an internal or external thread while DN 50 is supplied with external thread only. Dimensions DN 65-100 are supplied as flanged valves.

Connection of the valves is simple with all serviceable features at 90° to the pipework, easy connection for the impulse tube and a large selection of spares for all valves in the range.

ASV-PV valves are to be mounted in return pipe, in combination with partner valves mounted in flow pipe. As a partner valve ASV-M/ASV-BD are recommended for dimensions DN 15 to DN 50 and MSV-F2 for dimensions DN 65 to DN 100.

ASV-PV balancing valve inclusive 1.5m impulse tube (G 1/16 A) and drain cock (G 3/4 A)						
Type	DN	Kvs (m³/h)	Connection		Δ bar setting range	Code No.
	15	1.6	Internal thread ISO 7/1	Rp 1/2	0.05 - 0.25	003L760100
	20	2.5		Rp 3/4		003L760200
	25	4.0		Rp 1		003L760300
	32	6.3		Rp 1 1/4	0.20 - 0.60 ¹⁾	003L760400
	40	10.0		Rp 1 1/2		003L760500
	15	1.6		Rp 1/2		003L771100
	20	2.5		Rp 3/4		003L771200
	25	4.0		Rp 1	003L771300	
	32	6.3		Rp 1 1/4	003L771400	
	40	10.0		Rp 1 1/2	003L771500	
32	6.3	Rp 1 1/4	0.35 - 0.75	003L761600		
40	10.0	Rp 1 1/2		003L761700		
	50	20	External thread ISO 228/1	G 2 1/2 A	0.05 - 0.25	003Z061100
					0.20 - 0.40	003Z062100
					0.35 - 0.75	003Z063100
					0.60 - 1.00	003Z064100

ASV-PV balancing valve inclusive 1.5m impulse tube (G 1/16 A)						
Type	DN	Kvs (m³/h)	Connection		Δ bar setting range	Code No.
	65	1.6	Flange EN 1092-2	PN16	0.20 - 0.40	003Z062300
	80	2.5				003Z062400
	100	4.0				003Z062500
	65	6.3			0.35 - 0.75	003Z063300
	80	10.0				003Z063400
	100	1.6				003Z063500
	65	2.5				003Z064300
	80	4.0			0.60 1.00	003Z064400
	100	6.3				003Z064500

ASV-BD shut-off valve, multifunctional partner valve (shut-off, rotating measuring station)					
Type	DN	Kvs (m³/h)	Internal Thread		Code No.
	15	3.0	Rp 1/2		003Z404100
	20	6.0	Rp 3/4		003Z404200
	25	9.5	Rp 1		003Z404300
	32	18	Rp 1 1/4		003Z404400
	40	26	Rp 1 1/2		003Z404500
	50	40	Rp 2		003Z404600

ASV-M shut-off valve, multifunctional partner valve (shut-off, rotating measuring station)					
Type	DN	Kvs (m³/h)	Connection		Code No.
	15	1.6	Internal thread	Rp 1/2	003L769100
	20	2.5		Rp 3/4	003L769200
	25	4.0		Rp 1	003L769300
	32	6.3		Rp 1 1/4	003L769400
	40	10		Rp 1 1/2	003L769500
	50	16		External thread ISO 228/1	G 2 1/2 A

Differential Pressure Controller AVPL



AVPL Differential pressure control valve Includes impulse tube set (1.5m at Kvs 1.0 and 2.5m at Kvs 1.6) and nipple $1/16 - R^{3/8}$					
DN (mm)	Kvs (m ³ /h)	Connection		ΔP Setting Range (bar)	Code No.
15	1.0	External thread ISO 228/1	G $3/4$ A	0.05 - 0.25	003L503001
	1.6				003L503101

- Maintains a constant differential pressure regardless of flow rates
- Establishes and maintains system balance
- Compact design, ideal for consumer units
- Self-acting controls, no external power required

AVPL differential pressure control valves are used in block and district heating systems to reduce and maintain differential pressure within a dwelling.

Accessories				
Type	DN (mm)	Connection		Code No.
Weld-on tailpieces	15	-		003H690800
External tailpieces		Conical ext. thread according to EN 10226-1		R $1/2$ 003H690200
Fitting for impulse tube connection to pipe				G $1/16 - R^{1/4}$ 003L815100
10 EPDM o-rings for impulse tube				003L817500



Self-Acting Differential Pressure Control Valves

AVP



AVP self-acting differential pressure control valves are primarily for use in district heating systems. The controller closes on rising differential pressure.

AVP Controller (Return Mounting)									
DN	Kvs m ³ /h	Connection		Δ bar setting range	Code No.	Δ bar setting range	Code No.	Δ bar setting range	Code No.
15	1.6	Cylinder ext. thread acc. to ISO 228/1	G ¾ A	0.2-1.0	003H620600	0.8-1.6	003H621200	0.3-2.0	003H629300
	2.5				003H621300		003H621300		003H629400
	4.0				003H620800		003H621400		003H629500
20	6.3		G 1 A		003H620900		003H621500		003H929600
25	8.0		G 1¼ A		003H621000		003H621600		003H629700
32	12.5		G 1¾ A		-		003H621700		-
40	16		G 2 A		-		-		-
50	20		G 2½ A		-		-		-
32*	12.5		G 1¾ A		-		-		003H635400
40*	20		G 2 A		-		-		003H635500
50*	25	G 2½ A	-	-	003H635600				

* Flanged connections

AVP Controller (Flow Mounting)							
DN	Kvs m ³ /h	Connection		Δ bar setting range	Code No.	Δ bar setting range	Code No.
15	1.6	Cylinder ext. thread acc. to ISO 228/1	G ¾ A	0.2-1.0	003H624400	0.3-2.0	003H632500
	2.5				003H624500		003H632600
	4.0				003H624600		003H632700
20	6.3		G 1 A		003H624700		003H632800
25	8.0		G 1¼ A		003H624800		003H632900
32*	12.5		G 1¾ A		003H637200		003H637800
40*	16		G 2 A		003H637300		003H637900
50*	20		G 2½ A		003H637400		003H638000

* Flanged connections

Accessories			
Description	DN No.	Connection	Code No.
Weld-on tailpieces	15	-	003H690200
	20		003H690300
	25		003H690400
	32		003H690500
	40		065F606100
	50		065F606200
Impulse tube	Description: 1 x copper tube Ø6 x 1 x 15m		R ¹ / ₈ 003H685200
	1 x compression fitting got impulse tube connection to pipe Ø6 x 1mm		R ³ / ₈ 003H685300
			R ¹ / ₂ 003H685400
10x compression fittings for impulse tube connection to pipe Ø6 x 1, R ¹ / ₈ "			003H685700
10x compression fittings for impulse tube connection to pipe Ø6 x 1, R ³ / ₈ "			003H685800
10x compression fittings for impulse tube connection to pipe Ø6 x 1, R ¹ / ₂ "			003H685900
10x compression fittings for impulse tube connection to pipe Ø6 x 1, G ¹ / ₈ "			003H693100
Shut off valve Ø6mm			003H027600

Actuators			
Description	Δ bar setting range	Code No.	
		Return Mounting	Flow Mounting
Actuator (with adjustable handle for ΔP)	0.2-1.0	003H682900	003H683400
Actuator (with adjustable handle for ΔP)	0.3-2.0	003H683000	003H683500

Self-Acting Differential Pressure Controller

AFP

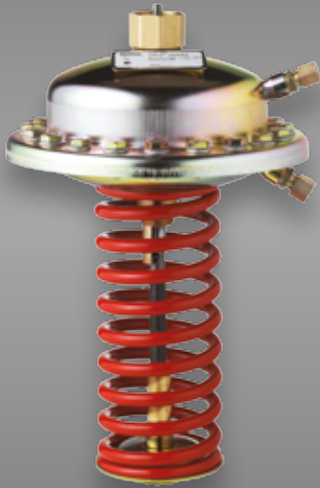

VFG 2							
DN (mm)	Kvs (m ³ /h)	Tmax (°C)		Connections	PN16	PN25	PN40
15	4.0	150	200 ¹⁾	Flange	065B238800	065B240100	065B241100
20	6.3				065B238900	065B240200	065B241200
25	8.0				065B239000	065B240300	065B241300
32	16				065B239100	065B240400	065B241400
40	20				065B239200	065B240500	065B241500
50	32				065B239300	065B240600	065B241600
65	50				065B239400	065B240700	065B241700
80	80				065B239500	065B240800	065B241800
100	125				065B239600	065B240900	065B241900
125	160				065B239700	065B241000	065B242000
150	280	140			065B239800		065B242100
200	210				065B249900	-	065B242200
250	400				065B240000		065B242300

The VFG 2 valves combine with the AFP and AFPA self-acting differential pressure controllers, and are designed for use in district heating systems.

Type	Δ bar setting range (bar)	For DN	Code No.
AFP ¹⁾	1 - 6	15 - 125	003G101400
	0.5 - 3		003G101500
AFP	0.15 - 1.5	15 - 250	003G101600
	0.1 - 0.7		003G101700
	0.05 - 0.35		003G101800

¹⁾ Actuator does not have excess pressure safety valve

Designed for use with VFG valves, AFP is a self-acting differential pressure controller primarily used in district heating systems. The controller closes on rising differential pressure.

Accessories			
Type	Description	Connections	Code No.
Impulse tube set AF	1 x copper tube Ø10 x 1.5m, one threaded fitting G ¹ / ₄ ", two sockets (2 required per AFP actuator)	-	003G139100
Seal pot V1	1.0l capacity with threaded fittings for Ø10mm tube	-	003G139200
Seal pot V2	3.0l capacity with threaded fittings for Ø10mm tube	-	003G140300
KF2	For combination with pressure and electrical actuators	G 1 ¹ / ₄ " / 2 x G 1 ¹ / ₄ "	003G139800
KF3	For combination with thermostat		003G139700



Sizing Chart

AB-QM

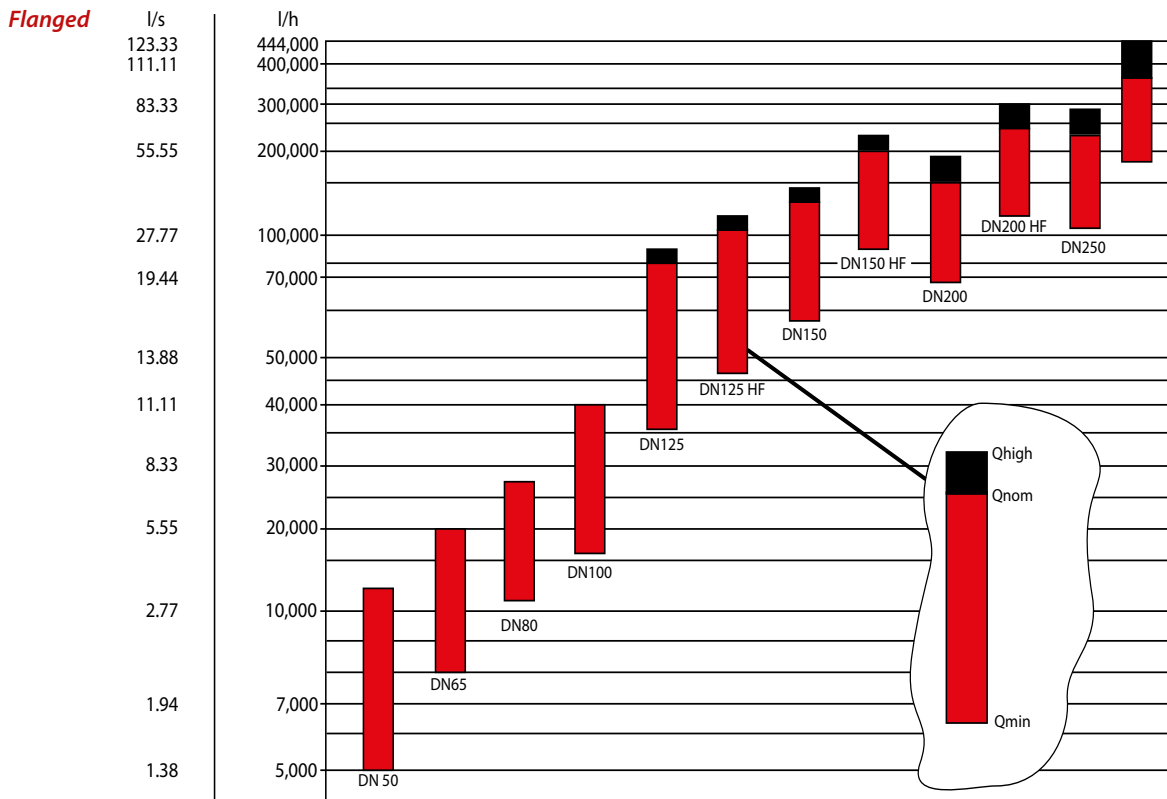
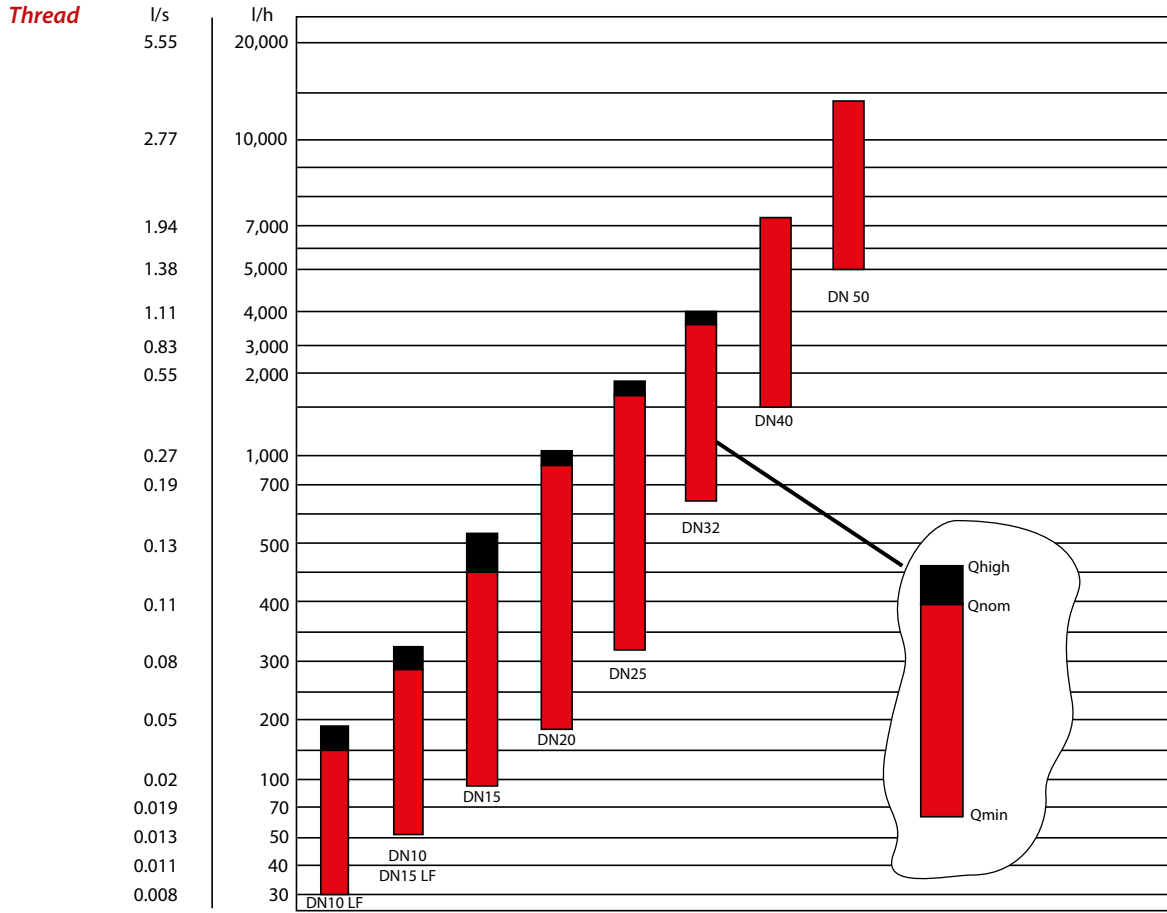

Pressure Independent Balancing and Control Valve **AB-QM**



DN	Q _{max} (l/h)	With measuring points		Without measuring points	
		External Thread	Code No.	External Thread	Code No.
10 LF	150	G ½ A	003Z126100	G ½ A	003Z125100
10	275		003Z121100		003Z120100
15 LF	275	G ¾ A	003Z126200	G ¾ A	003Z125200
15	450		003Z121200		003Z120200
20	900	G 1 A	003Z121300	G 1 A	003Z120300
25	1,700	G 1¼ A	003Z121400	G 1¼ A	003Z120400
32	3,200	G 1½ A	003Z121500	G 1½ A	003Z120500
40	7,500	G 2 S	003Z077000		
50	12,500	G 2½ A	003Z077100		
DN	Q _{max} (l/h)	Flange Connection	Code No.		
50	12,500	PN 16	003Z077200		
65	20,000		003Z077300		
80	28,000		003Z077400		
100	38,000		003Z077500		
125	90,000		003Z070500		
125 HF	110,000		003Z071500		
150	145,000		003Z070600		
150 HF	190,000		003Z071600		
200	190,000		003Z070700		
200 HF	250,000		003Z071700		
250	280,000		003Z070800		
250 HF	370,000		003Z071800		

- No Kv or authority calculations needed. Flow is the only parameter to be considered when designing
- Maximum setting corresponds with international standards for flow speeds in pipes
- Linear or logarithmic characteristic when combined with gear actuators
- Compact design
- Easy commissioning
- Energy savings
- Increased comfort
- Easy trouble shooting
- Fast start-up - AB-QM does not need to be flushed or de-aired before use

The AB-QM is a PIBCV (Pressure Independent Balancing and Control Valve) which combines the benefits of a control valve and a differential pressure controller, which work in tandem to provide the ultimate in system control and setting accuracy. The differential pressure controller within the valve keeps a constant differential pressure across the valve cone, meaning that changes in system pressure do not affect the control characteristics of the valve.

Setting the valve is simple – all you need to know is the required flow through the valve, and the max flow of the valve. With these two figures you just divide one by the other to establish the correct setting for the valve e.g. Design flow (270l/h) / Valve max flow (450l/h) x 100 = 60% setting on the dial. Different sizes of ABQMs cover a range of maximum flows, enabling the right size valve for the application to be selected easily. The maximal flow speeds of AB-QM corresponds with the maximal flow speed through pipe dimensions according to international standards. With a standard M30x1.5 connection the AB-QM is suitable for a range of actuators providing control solutions for 0-10v, 3point and on/off control.

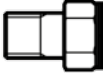
Accessories and Spare Parts			
Type	To pipe	To valve	Code No.
Union connection (1 pcs.) 	R ¾	DN 10	003Z023100
	R ½	DN 15	003Z023200
	R ¾	DN 20	003Z023300
	R 1	DN 25	003Z023400
	R 1¼	DN 32	003Z023500
	R 1½	DN 40	003Z027900
Tailpieces for soldering (2 nuts, 2 gaskets, 2 soldering nipples)	12 x 1 mm	DN 10	065Z701600
	15 x 1 mm	DN 15	065Z701700
Locking ring		DN 10-32	003Z023600
Shut-off & protection piece (max. closing pressure 16 bar)			003Z023000
Shut-off - plastic (max. closing pressure 1 bar)			003Z024000
Handle AB-QM (for details refer to instructions)		DN 40-100	003Z069500
		DN 125-250	003Z069600

For actuator combinations see page 74 and 75

Actuator Selection Chart

AB-QM

				TWA-Z	ABNM A5	AMI 140	
Supply	3-Position	Modulating	Safety Function	ON/OFF	0-10V		
24	✓		✗				
24	✓		✓				
24		✓	✗		ABNM A5	AMI 140	
230	✓		✗				
230	✓		✓				
230		✓	✓			AMI 140	
Potentiometer	✓	✗	✓	✗	✗	✗	
Switch	✓	✗	✓	✗	✗	✗	
				Speed (s/mm)	24	24	12
				F (N)	100	100	200
				Stroke (mm)	3	3	5.5

PN Bar	Tmax °C	Valve Type	DN (mm)	Max flow l/h	Stroke (mm)			
16	-10 - +120°C	AB-QM - Down to close	10 LF	0-150	2.25	✓	✓	✓
			10	0-275				
			15 LF	0-275				
			15	0-450				
			20	0-900				
			25	0-1700				
	32		0-3200	4.5	✗			
	-10 - +200°C		40	7,500	10	✗	✗	✗
			50	12,500	10			
			65	20,000	15			
			85	28,000	15			
			100	38,000	15			
			125	190,000	25			
			125 HF	110,000	30			
			150	145,000	25			
			150 HF	190,000	30			
			200	190,000	27			
			200 HF	250,000	27			
250		280,000	27					
250 HF	370,000	27						



NovoCon®	AMV/E 110 NL - 120 NL		AMV/E/H 130 - 140		AME 435 QM	AME 55 QM	AME 85 QM
	AMV 110NL	AMV 120NL	H=Knob Version				
	AMV 110NL	AMV 120NL	AMV 130	AMV 140	AME 435 QM	AME 55QM	AME 85 QM
	AME 110 NL	AME 120NL	AME 130	AME 130 AMV 130	AME 435 QM	AME 55 QM	AME 85 QM
	X	X	X	X	✓	✓	✓
	X	X	X	X	✓	✓	✓
3, 6, 12, 24	24	12	24	12	7.5 or 15	8	8
90	130	130	200	200	400	2000	5000
6	5	5	5.5	5.5	20	40	40
✓	✓	✓	✓	✓	X	X	X
X	X	X	X	X	✓	X	X
					X	✓	
						X	✓

NovoCon® S

Four-in-one actuator

Actuator

NovoCon® is a highly accurate multi-functional actuator designed for use with AB-QM in sizes from DN 10-32. It delivers best-in-class hydronic performance in, e.g. fan coil units, chilled beams, and radiant panels.

Flow indicator

NovoCon® functions as a flow indicator thanks to the high position accuracy of the actuator and the pressure independent and linear characteristics of the AB-QM valve.



Bus communication device

With the NovoCon® it is now possible to connect hydronics to Building Automation. All setting and control is possible via Fieldbus and requires only minimal data points.

Data logger

The NovoCon® facilitates collection and storage of data that can be used to benchmark building performance over time, and to identify best practice in energy consumption behavior.

Best in class hydronic performance
combined with BMS connectivity

Digital Actuator

NovoCon®



Type	Code
NovoCon® Hybrid	003Z850000
NovoCon® Digital	003Z850100

Type	Length	Connections	Code
Cable NovoCon® Digital	1.5 m	bus / power	003Z860000
Cable NovoCon® Digital	5 m	bus / power	003Z860100
Cable NovoCon® Digital	10 m	bus / power	003Z860200
Cable NovoCon® Digital, daisy chain	1.5 m	actuator / actuator	003Z860300
Cable NovoCon® Digital, daisy chain	5 m	actuator / actuator	003Z860400
Cable NovoCon® Digital, daisy chain	10 m	actuator / actuator	003Z860500
Cable NovoCon® Analog	1.5 m	0-10 V / power / voltage booster	003Z860600
Cable NovoCon® Analog	5 m	0-10 V / power / voltage booster	003Z860700
Cable NovoCon® Analog	10 m	0-10 V / power / voltage booster	003Z860800

Please note: Cables are not included with actuator and must be ordered separately.

Type	Code
Power supply range	24 V AC/DC, ± 25%, 50 / 60 Hz
Power consumption	Running: 3.25 VA / Standby: 0.8 W
Protection class	III safety extra-low voltage
Electrical connection	Halogen free cable
Control options	LOG / MDF (alpha setting controlled)
Control signal NovoCon® Hybrid	0-10 VDC, 0-5 VDC, 2-10 VDC, 5-10 VDC, 2-6 VDC, 6-10 VDC, 0-20 mA, 4-20 mA, BACnet MS/TP
Control signal NovoCon® Digital	BACnet MS/TP
Actuator speed selections (open to close)	3 sec/mm, 6 sec/mm, 12 sec/mm, 24 sec/mm, Constant Time
Stroke	6 mm
Force	90 N
Position accuracy	± 0.05 mm
Ambient temp. range	-10° C to 55° C
Max. medium temp.	120° C
Storage temp. range	-40 to 70 °C
Grade of enclosure	IP 54 (IP 40 upside down)
Weight	0.4 kg

BACnet data

Type	Length
BACnet device profile	BACnet Application Specific Controller (B-ASC)
BACnet protocol	BACnet Master Slave / Token Passing (MS/TP)
BACnet baud rates supported	Auto baud rate detection / 9600 bps / 19200 bps / 38400 bps / 56700 bps / 76800 bps / 115200 bps

- BACnet: B-ASC (BACnet Application Specific Controller)
- Remote commissioning/Reset/Flush features
- Flow indication
- High position accuracy
- LED bar displaying status
- No tools required for mounting
- Maintenance-free during lifetime
- Valve blockage alarm

NovoCon® Digital Actuator is a high accuracy multi-function actuator, specifically designed for use in combination with Pressure Independent Balancing Control Valve type AB-QM in sizes from DN 10-32.

The high position accuracy of the actuator, together with the pressure independent and linear characteristic of AB-QM valve, allow NovoCon® Digital Actuator to be used as flow indicator.

Setup of actuator and valve parameters is made via fieldbus. Control is made via analog inputs or field bus for NovoCon®. NovoCon® Digital Actuator is controlled via field bus.

The actuator with AB-QM is used to control water supply to fan coil units, chilled beams, induction units, small re-heaters, re-coolers, AHU's and other terminal units for zone control in which hot/cold water is the controlled medium. Due to its accuracy, remote functionality and flow indication features can significantly add to an accelerated commissioning process, easy maintenance, improved indoor comfort, energy saving and fair allocation of heat/cool energy.



AB-QM Actuators

TWA-Z and ABNM



Use with AB-QM DN10-20 and DN25-32 (Qmax 60%)

- Cost effective
- On/Off control
- Valve position indicator
- 24 or 230 Vac/dc
- Available in Normally Open (NO) or Normally Closed (NC)

Technical Data	
Type	TWA-Z
Supply voltage	24 Vac/Vdc, 230 Vac/Vdc +10 to -15%
Frequency	50/60Hz
Consumption	2 W
Power output	90N
Max Stroke	2.8mm
Full Stroke Time	Approx. 3 minutes
Grade of enclosure	IP 41
Ambient temperature	2 to 60°C

Type	Power Supply	Code No.
TWA-Z NC 1.2m cable	24 Vac/Vdc	082F138000
TWA-Z NC 1.2m cable	230 Vac/Vdc	082F138200
TWA-Z NC 5m cable	24 Vac/Vdc	082F138400
TWA-Z NC 5m cable	230 Vac/Vdc	082F138800

Use with AB-QM DN10-20 and DN25-32 (Qmax 85%) ABNM Thermal Actuator

- Thermoelectric
- 0-10V control
- Automatic calibration - optical path measurement allows very accurate positioning
- Theft protection
- Ideal for use in fast heating/cooling systems (e.g. fan coils, air conditioner boxes etc.)
- Normally Closed, apply power to open

Type	Power Supply	Code No.
ABNM	24V (0.01V)	082F116000

Technical Data	
Type	ABNM A5
Supply voltage	24 Vac, -10 to +20%
Frequency	50/60Hz
Consumption	2 W
Power output	100N
Max Stroke	5mm
Full Stroke Time	30 sec p/mm
Grade of enclosure	IP54
Ambient temperature	0 to 60°C

Accessories	
Cables	Code No.
1 metre	082F108100
5 metres	082F108200
10 metres	082F108300

AB-QM Actuators

AME/AMV 110/120 NL

AME 110 NLX

AMI 140



Type	Supply Voltage (V)	Speed (s/mm)	Cable Length (m)	Code	
AMV 110 NL	24 AC	24	1.5	082H805600	
			5.0	082H807600	
			10	082H808600	
AMV 120 NL		12	1.5	082H805800	
			5.0	082H805700	
			10	082H808700	
AME 110 NL		24	24	1.5	082H806000
				5.0	082H806200
				10	082H806400
AME 110 NLX				12	1.5
	082H805900				
	082H804800				
AME 120 NL					
AMI 140					

Used in conjunction with automatically balanced combination valve type AB-QM in sizes DN10 to DN32, the AME actuators can be used for control of fan coil units, induction units, small re-heaters, re-coolers and zone applications where hot/cold water is the controlled medium.

AME actuators offer modulating control, while AMV offer 3-point control.

Compatible Valves

AME/AMV

AB-QM (DN10-DN32).....Page 73

AMI

AB-QM (DN10-DN32).....Page 73

Technical Data			AME 110 NLX	AME 110 NL	AME 120 NL	AMV 110 NL	AMV 120 NL	AMI 140
Type								
Power supply		V	24 AC					
Power consumption	Running	VA	1.5	2		1		1
	Standby	W	0.4	0.5		0		-
Frequency		Hz	50/60					
Closing Force		N	130					200
Stroke		mm	5					5.5
Speed		mm/s	24	12	24		12	
Max. medium temperature		°C	120					130
Ambient temperature			0 ... 55					
Protection class			III					
Grade of enclosure			IP42					IP42



Climate Sensor - FEV-Z

Self-Acting Thermostatic Actuator - QT



- Non-electric proportional control
- Direct acting valve controller
- Easy set and install process
- Suitable for AB-QM valves DN10 – DN20 and RA-C/N/G valves
- Range limiting function

The FEV-Z climate sensor is a proportional controller which opens or closes an AB-QM automatic flow limiter valve dependant on the difference in temperature from the set-point. If the temperature in the room is equal or below setpoint then the valve will remain open, closing should the space temperature increase above set-point. The FEV-Z is used in climate systems with ceiling, floor or radiator heating.

Heating: Floor, Ceiling or Radiator Heating

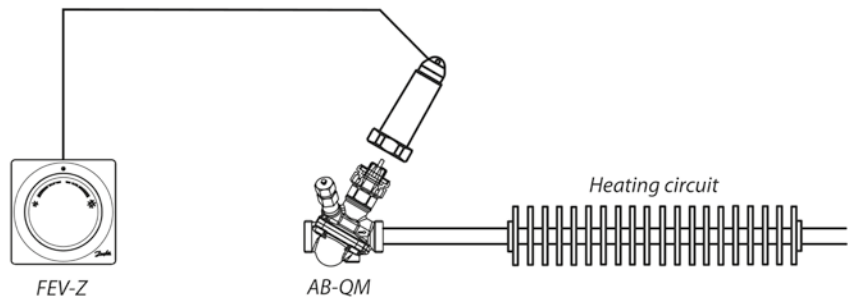

Type	Description	Setting Range	Code No.
FEV-Z	Climate sensor with adapter for AB-QM automatic flow limiter, 8 m capillary tube	17 - 27 °C	013G545800

- Setting range: 35-50°C, 45-60°C
- Designed for AB-QM DN 10-32
- Easy to install external surface sensor
- Reduces actual riser flow to match heat demand
- Improved room temperature control
- Reduced overheating of the building
- Reduced heating cost

QT is a self-acting thermostatic actuator designed to be used in combination with AB-QM in one-pipe heating systems. AB-QM together with QT converts a one-pipe heating system into an energy efficient variable flow system, where flow in the risers is dynamically adjusted to match the load in the riser by control of return water temperature.

QT is dedicated to be used with AB-QM automatic balancing and control valve.

AB-QM together with QT is a complete one-pipe solution: ABQT.

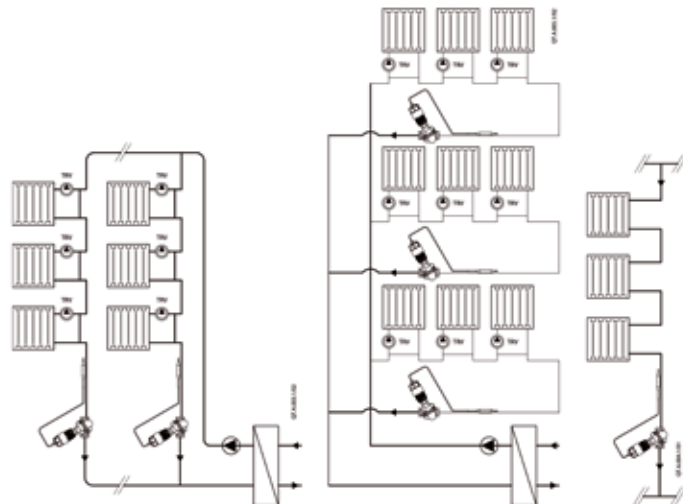

QT Thermostatic Actuator	Setting Range	Fits to AB-QM	Code No.
	45-60	DN 10-20	003Z038200
		DN 25-32	003Z038300
	35-50	DN 10-20	003Z038400
		DN 25-32	003Z038500
Setting range		35-50	45-60
Temperature tolerance			±3
P-Band ¹⁾	°C		5 ¹⁾ /8 ²⁾
Max temperature at sensor			90
Capillary tube length	m		0.6
1) with AB-QM DN 10-20, at 50 % flow setting			
2) with AB-QM DN 25-32, at 50 % flow setting			

Combined Automatic Balancing Valve **AB-PM** **DN15-25**



DN	Ext. thread (ISO 228/1)	Code
15	G ¾ A	003Z140200
20	G 1 A	003Z140300
25	G 1¼ A	003Z140400

Includes 1.5m impulse tube and impulse tube adapter

- More reliable heating system performance
- Lower heating cost
- Better indoor temperature control

Accessories			
Type	Power Supply	Cable Length	Code No.
TWA-Z NC	24V AC	1.2m	082F138000
	230V AC		082F138200
Type	To Pipe	To Valve	Code No.
Union Connection	R ½	DN 15	003Z023200
Union Connection	R ¾	DN 20	003Z023300
Union Connection	R 1	DN 25	003Z023400
Union Connection	½" (Internal thread)	DN 15	003Z395500
Union Connection	¾" (Internal thread)	DN 20	003Z395600
Union Connection	1" (Internal thread)	DN 25	003Z395700

AB-PM, is a combined automatic balancing valve. It incorporates a differential pressure controller, a flow limiter and a zone controller. Three functions in a single valve. The perfect solution for two-pipe radiator and underfloor heating systems, AB-PM is reliable and easy to maintain, and provides a solution that helps reduce heating costs, improves indoor comfort and eliminates system noise.

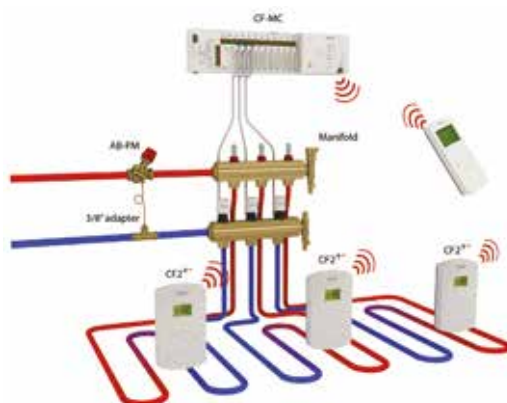
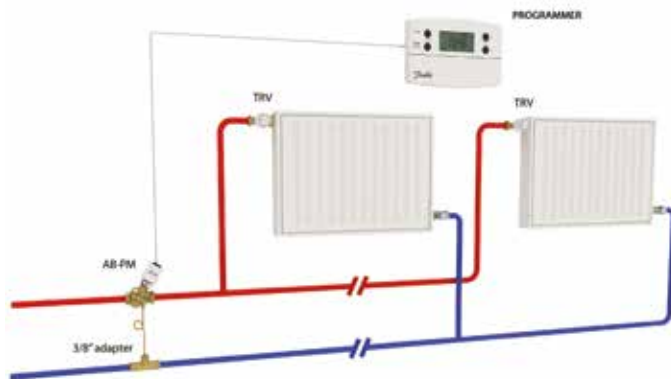

AB-QM Actuators

AME 55 / 85 / 435 QM



The AME QM actuators are used with the AB-QM pressure independent balancing and control valve.

The actuators automatically adapt the stroke to the valve end positions which reduces commissioning time. They are very flexible actuators, which can be controlled by all types of control signals like voltage and current.

Compatible Valves

AME 435 QM
AB-QM (DN40-DN100).....Page 73

AME 55 QM
AB-QM (DN125-DN150).....Page 73

AME 85 QM
AB-QM (DN200-DN250).....Page 73

Type	Supply Voltage (V)	Speed (s/mm)	Code
AME 55 QM	24 V	8 mm/s	082H307800
AME 85 QM	24 VAC		082G145300
AME 435 QM	24 VAC/DC	7.5 or 15 mm/s	082H017100

Technical Data		AME 55 QM	AME 85 QM	AME 435 QM
Type				
Power consumption	VA	9 VA	12.5 VA	4.5 VA
Frequency	Hz	50/60 Hz		
Closing Force	N	2000	5000	400
Max. Stroke	mm	40		20
Max. medium temperature	°C	200		120
Ambient temperature		0 ... 55		
Protection class		II		
Grade of enclosure		IP 54		



Differential Pressure By-Pass Valves

The self-acting differential pressure relief by-pass controllers and pressure relief by-pass controllers are primarily for use in district heating systems.

The controllers open on rising differential pressure or pressure.

The controllers have a control valve, an actuator with control diaphragm and a spring for differential pressure setting.

Function of the controller: the diaphragm in the controller regulates the differential pressure of the valve according to the effect, which the spring power has on the diaphragm. The valve is normally closed and opens at rising differential pressure.

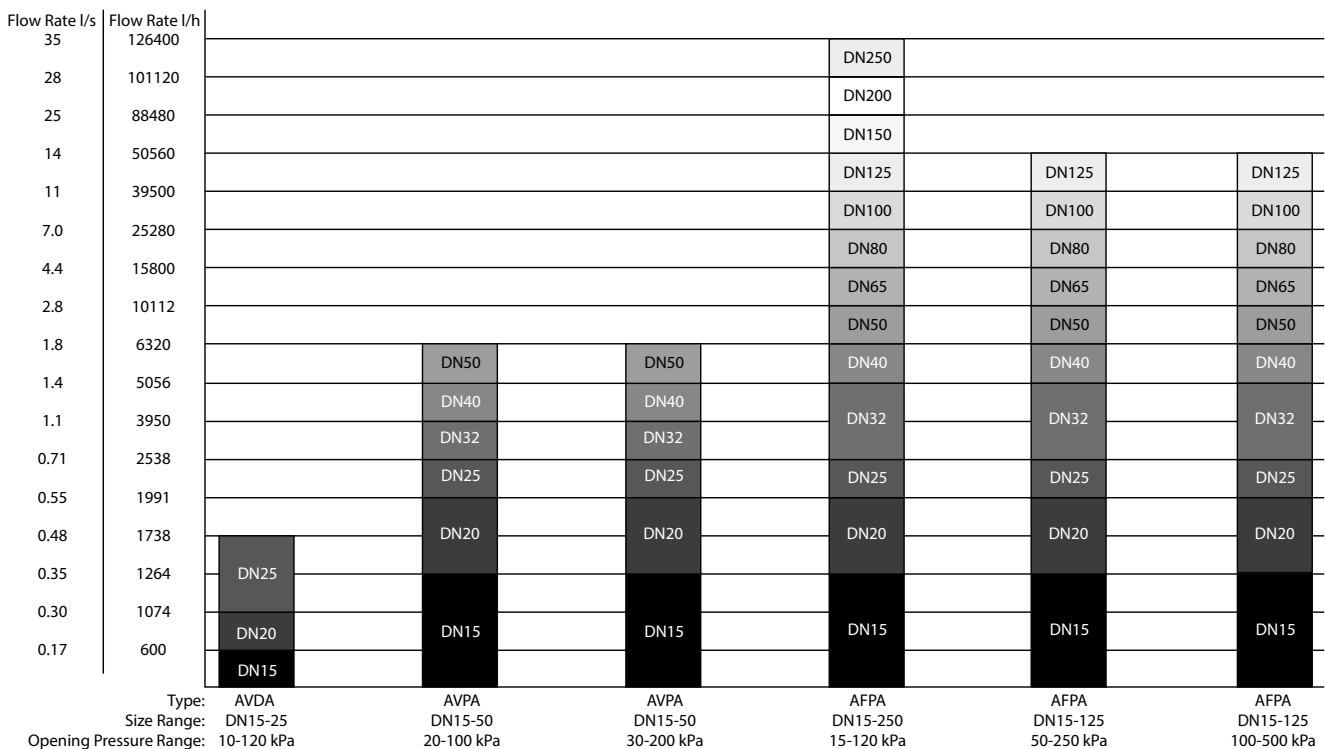

This chart is for guidance only. Any selections must be checked with a Danfoss representative before a final selection can be made.

An assumed maximum pressure loss, across the valve, of 10kPa has been applied. Higher flow ranges can be achieved by increasing the differential pressure across the valve. To select, take your required design flow rate. Find the flow points it falls between on the flow axis, draw a line horizontally. The valve sizes on the line are acceptable sizes to select. The opening pressure is the differential pressure at which the valve will start to open. Please ensure you select a valve with a suitable opening pressure for your application. The DPBV should be installed between the flow and return pipework. Consult Danfoss for guidance on installation.

Automatic Bypass Valves

AVDO

DN15 - DN25



- Self acting flow controller
- Opens on rising differential pressure
- DN15, DN20, DN25
- Setting range of 0.05 to 0.5 bar
- Internal/External thread variants

The AVDO range of automatic bypass valves can be used as either differential pressure controls or to provide a minimum flow through a system.

Available in a variety of sizes, the capacity of this range of valves is very high with large but linear changes in water throughput for relatively small increases in differential pressure. This allows a 15mm valve to be used in situations where 22mm valves are normally required.

Setting Range	0.05 - 0.5 bar
Max. differential pressure	0.5 bar
Operation pressure	PN 10
Max. flow temperature	120°C
Max. leakage at closed valve	50 l/h

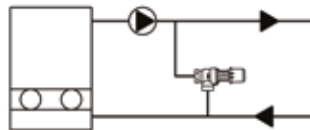

*Low capacity gas boiler
where maintenance of a
minimum flow is required*

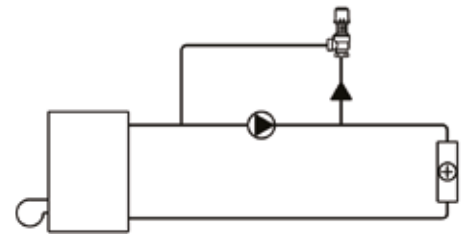

Differential pressure control

Code Number	Type	Setting Range (Bar)	Inlet Connection	Outlet Connection	Design
003L601800	AVDO 15	0.05 - 0.5	Rp ½"	Rp ½"	Straight
003L602300	AVDO 20	0.05 - 0.5	Rp ¾"	Rp ¾"	Straight
003L602800	AVDO 25	0.05 - 0.5	Rp 1"	Rp 1"	Straight
003L611500	AVDO*	0.05 - 0.5	15mm	15mm	Straight
003L612200	AVDO*	0.05 - 0.5	22mm	22mm	Straight
003L612800	AVDO*	0.05 - 0.5	28mm	28mm	Straight

* incl. compression fittings for copper pipe

By-Pass Valves AVDA

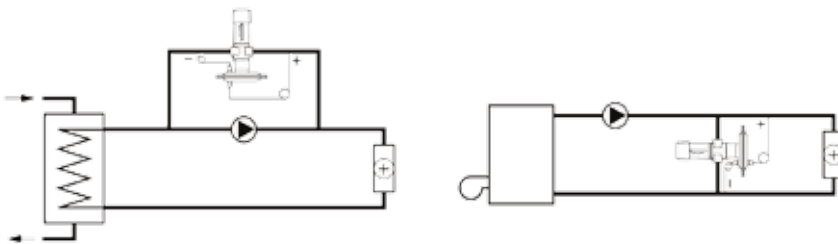

Application Examples

Self-acting differential pressure relief controller used for constant flow control or by-pass control primarily for apartment block heating, district heating plant and central heating systems. The controller opens on rising differential pressure.

DN (mm)	Kvs m ³ /h	PN	Δ bar setting range	Connection - valve (int. thread ISO 7/1)	Connection - impulse tube flare	Code No. ¹⁾
15	1.9	10	0.1 - 1.2	RP ½	7/16-20 UNF	003N003800
20	3.4			RP ¾		003N003900
25	5.5			RP 1		003N004000

¹⁾ Includes 2 impulse tubes (0.5 and 1.5m) with compression fitting

Accessories		
Type	DN	Code No.
Repair Kit	DN15	003N400600
	DN20	003N400700
	DN25	003N400800
Diaphragm housing	-	003N006500
Nipple	-	631X470000

Self-Acting Differential Pressure Relief Controller

AVPA DN15-DN50



Self-acting differential pressure relief controller primarily for use in district heating systems. The controller is normally closed and opens on rising differential pressure.

The controller has a control valve, an actuator with one control diaphragm and handle for differential pressure setting

DN (mm)	Kvs m ³ /h	PN	Connection	Δ bar setting range	Code No.	Δ bar setting range	Code No.	
15	4.0	PN16	Cylinder ext. thread acc. to ISO 228/1	G ¾ A	003H659300	0.2 - 1.0	003H659600	
20	6.3			G 1 A				003H659400
25	8.0			G 1¼ A				003H659500
15	4.0	PN25	Cylinder ext. thread acc. to ISO 228/1	G ¾ A	003H660200	0.2 - 1.0	003H660500	
20	6.3			G 1 A				003H660300
25	8.0			G 1¼ A				003H660400
32	12.5			G 1¾ A				003H659900
40	16			G 2 A				003H660000
50	20			G 2½ A				003H660100
32	12.5	Flanges, acc. to EN 1029-2			-		003H661100	
40	20				-		003H661200	
50	25				-		003H661300	

Fittings/Spare Parts			
Description	DN	Connection	Code No.
Tailpiece	15	R ½"	003H690200
	20	R ¾"	003H690300
	25	R 1"	003H690400
	32	R 1¼"	003H690500
	40	R 1½"	065F606100
	50	R 2"	065F606200
Actuator with adjustable handle for AVPA PN25 (0.2 - 1.0 bar)			003H683400
Actuator with adjustable handle for AVPA PN25 (0.3 - 2.0 bar)			003H683500



Pressure Actuator AFPA DN15-DN250

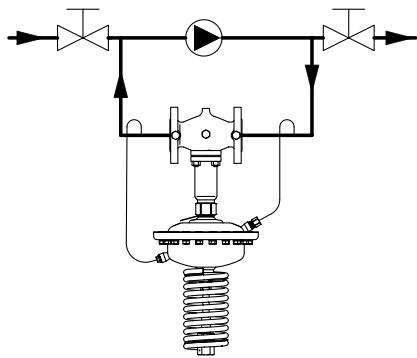

The VFG 2 valves combine with the AFPA self-acting differential pressure controllers, and are designed for use in district heating systems.

Hydronic Balancing
and Control



The AFPA pressure actuator with control diaphragm and a spring for differential pressure setting.

Combined with valve type VFG it is a self-acting differential pressure relief controller primarily used in district heating systems. The controller opens on rising differential pressure.

VFG 2							
DN (mm)	Kvs (m ³ /h)	Tmax (°C)		Connections	PN16	PN25	PN40
15	4.0	150	200 ¹⁾	Flange	065B238800	065B240100	065B241100
20	6.3				065B238900	065B240200	065B241200
25	8.0				065B239000	065B240300	065B241300
32	16				065B239100	065B240400	065B241400
40	20				065B239200	065B240500	065B241500
50	32				065B239300	065B240600	065B241600
65	50				065B239400	065B240700	065B241700
80	80				065B239500	065B240800	065B241800
100	125				065B239600	065B240900	065B241900
125	160				065B239700	065B241000	065B242000
150	280	140			065B239800	-	065B242100
200	210				065B249900		065B242200
250	400				065B240000		065B242300

Type	ΔP setting range (bar)	for DN	Code No.
AFPA	1.0 - 5.0	15 - 125	003G101900
	0.5 - 2.5		003G102000
	0.15 - 1.2	15 - 250	003G102100
	0.1 - 0.6		003G102200
	0.05 - 0.3		003G102300

Accessories		
Type	Description	Code No.
Impulse tube set AF	1 x copper tube Ø10 x 1.5m, one threaded fitting G1/4", two sockets	003G139100
Seal pot V1	1.0l capacity with threaded fittings for Ø10mm tube	003G139200
Seal pot V2	3.0l capacity with threaded fittings for Ø10mm tube	003G140300

Thermostatic Circulation Valve

MTCV



- Saves energy by limiting hot water circulation
- Provides water instantly at the right temperature
- Automatic disinfection process
- Electronic disinfection process
- Modular upgrading of the MTCV valve during operation, under pressurised conditions, is possible when using ½ or ¾ fittings with shut-off ball valves.
- Replaceable calibrated thermo-element

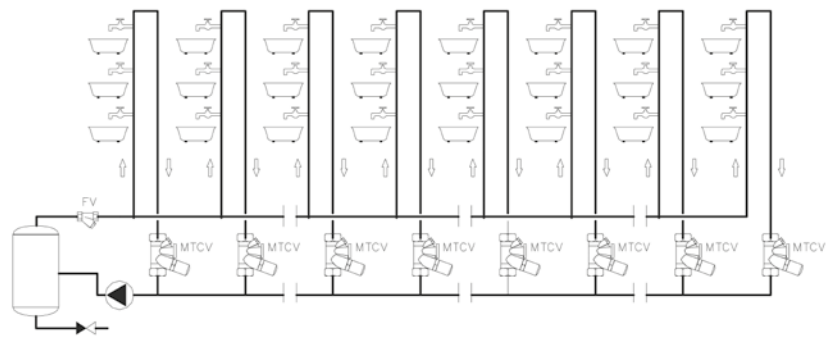

Example of MTCV / basic version / placement in domestic hot water system

The MTCV is a thermostatic self acting proportional valve, operating primarily through the use of a thermo-element to limit circulation flow in cases of high temperature. The setting scale allows the hot water temperature to be limited within a range of 35–60°C.

There are 2 versions of the MTCV available:

- Version 'A' – provides thermostatic balancing of the HW system within a set temperature range.
- Version 'B' – provides automatic thermal disinfection at temperatures above 68°C, with a safety feature to prevent temperatures in excess of 75°C.

Max. working pressure	10 bar
Test pressure	16 bar
Max. flow temperature	100°C
Kvs at 20°C	- DN 20 1.8 m ³ /h
	- DN 15 1.5 m ³ /h
Hysteresis	1.5 K

Material of parts in contact with water	
Valve body	Rg5
O-rings	EPDM
Spring, cones	Stainless steel

Valve - Basic version A	Code No.
DN 15	003Z151500
DN 20	003Z152000

Valve - Basic version B	Code No.
DN 15	003Z151100
DN 20	003Z155700

Accessories	Comments	Code No.
Thermostatic disinfection module - B	DN 15 / DN 20	003Z202100
Fittings with shut-off ball valve (for allen-key 5mm), DN 15	G ½ x Rp ½	003Z102700
	G ¾ x Rp ¾	003Z102800
Thermometer with adapter	DN 15 / DN 20	003Z102300
Adapter for thermo-actuator	DN 15 / DN 20	003Z102200
Temperature sensor ESMB Universal		087B118400
Temperature sensor ESMC contact		087N001100
Fittings for soldering Cu 15mm	DN 15	003Z103400
Fittings for soldering Cu 18mm	int. R ½"	003Z103500
Fittings for soldering Cu 22mm	DN 20	003Z103900
Fittings for soldering Cu 28mm	int. R ¾"	003Z104000

Measuring Equipment

PFM100



Description	Code No.
PFM100	003L826000

Accessories	Code No.
Measuring Hoses 2 x 1.5m	003L826100
Measuring Needle	003L826200
Quick Coupling	003L826300
Filters	003L826400
Strap	003L826500

- Easy commissioning
- Verification of pressure and flow
- 10 different languages
- Robust handheld device - IP65
- Universal measuring device - for any hydronic balancing valve

The PFM100 is a measuring device that measures the differential pressure on both sides of a valve in hydronic systems. After typing the kv value into the device it will calculate the flow in a very accurate manner. The PFM100 consists of a measuring instrument, two hoses with couplings and two measuring needles with ball valves.

Compatible Valves

MSV-O.....	Page 64
MSV-BD.....	Page 65
MSV-F2.....	Page 66

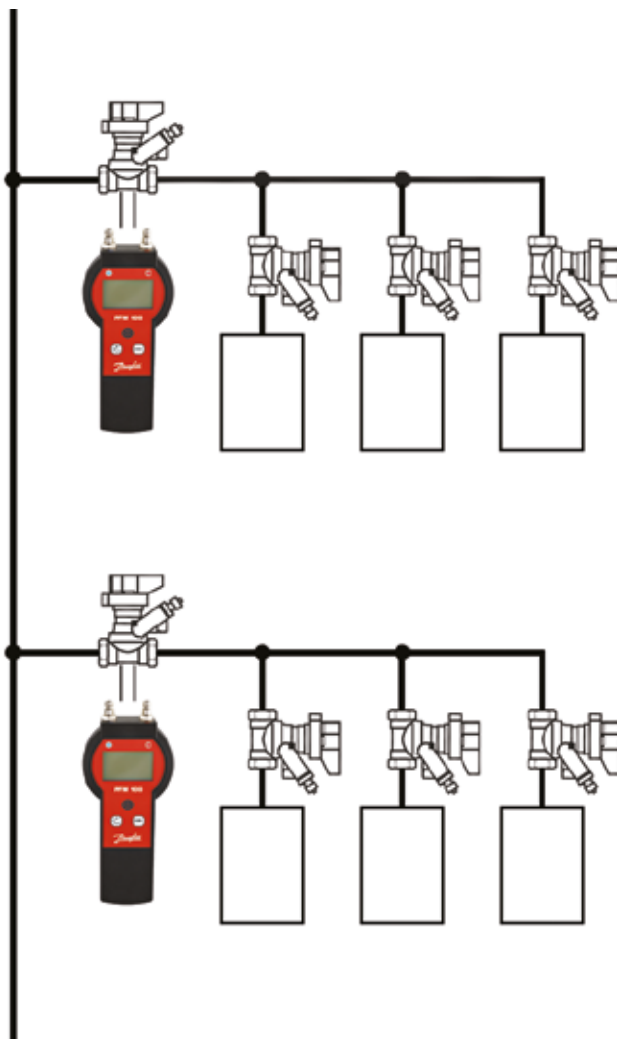

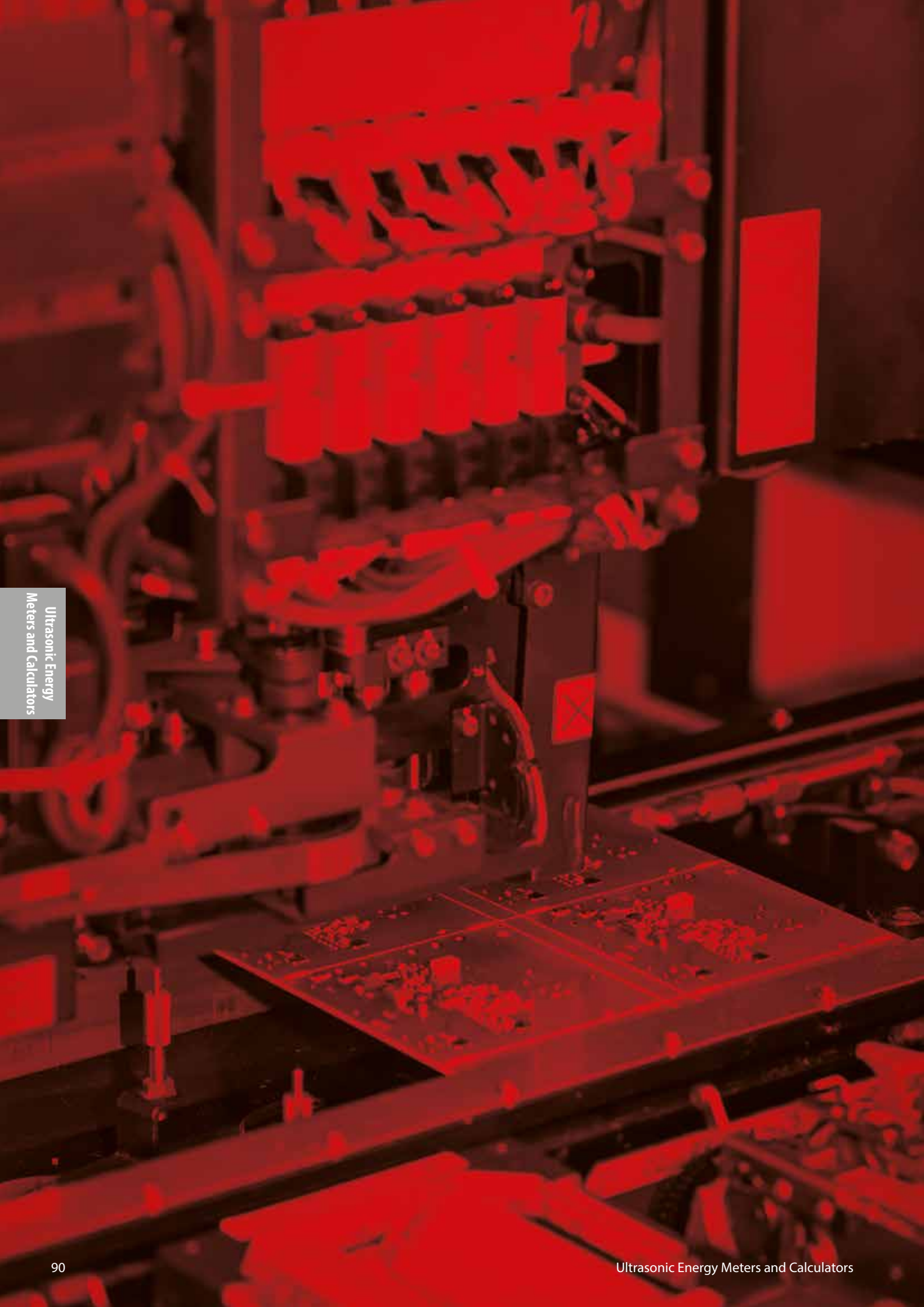

Ultrasonic Energy Meters and Calculators

Contents

With the increasing focus on energy savings and reducing CO2 emissions, measuring energy consumption is now a key focus of any district heating provider and end-user.

Energy consumption data ensures a transparent billing system for both district heating supplier and end user. By metering energy consumption, it is easy to keep track of the energy performance of any heating, district heating or cooling system.

Energy meters are the components that provide energy consumption measurement.

Ultrasonic Energy Meter - Sonometer.....	92
Energy Meter Sizing Chart	93



Ultrasonic Energy Meter Sonometer



- No wear and tear due to static metering with no moving parts
- 1st approval in Europe for ultrasonic heat meter with dynamic range of q_i/q_p 1:250 in class 2
- EN 1434 class 2 approval
- Replacing of the measuring insert without dismantling the transducers
- Power supply: battery, mains 230V ac or 24 V ac
- Remote reading via M-bus, radio, RS232 or optical interface
- Optional pulse input and pulse output module
- Radio module option for easy data transfer
- Battery lifetime up to 16 years
- MID examination certificate

The SONOMETER™500 is an ultrasonic static compact heat meter designed especially for residential sub-metering (i.e. HIUs).

The SONOMETER™1100 is an ultrasonic static compact heat meter especially designed for heating, cooling or combined heating/cooling application in local and district heating systems.

The SONOMETER™1100 as a compact heat meter consists of the following components:

- Ultrasonic flow sensor;
- Calculator with integral hardware and software for measuring flow rate, temperature and energy consumption;
- Temperature sensors.

These heat meters give a precise and easy measure of your system's performance using a patented ultrasonic technology that guarantees high accuracy and reliable long-term stability.

A larger meter is available for sizes DN125-300 in the form of Sono 3500. Details available on request.

Application

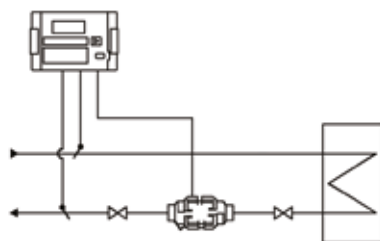

Measuring Accuracy to EN 1434 Class 2

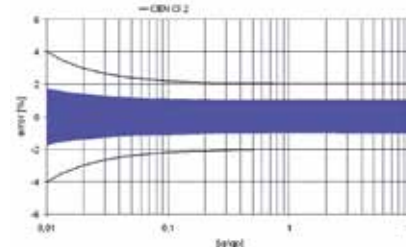

Sono 500

Code No.	Flow Sensor ¹	Nominal Pressure	Installation	Interface	Cable Length ²	Energy Unit
187F0500	qp 0.6m ³ /h /110mm thread/DN15/G¾B	PN16	Low temp.	M-BUS	1.45m	kWh
187F0501	qp 1.5m ³ /h /110mm thread/DN15/G¾B	PN16	Low temp.	M-BUS	1.45m	kWh
187F0502	qp 1.5m ³ /h /130mm thread/DN20/G1B	PN16	Low temp.	M-BUS	1.45m	kWh
187F0503	qp 2.5m ³ /h /130mm thread/DN20/G1B	PN16	Low temp.	M-BUS	1.45m	kWh
187F0504	qp 0.6m ³ /h /110mm thread/DN15/G¾B	PN16	High temp.	M-BUS	1.45m	kWh
187F0505	qp 1.5m ³ /h /110mm thread/DN15/G¾B	PN16	High temp.	M-BUS	1.45m	kWh
187F0506	qp 1.5m ³ /h /130mm thread/DN20/G1B	PN16	High temp.	M-BUS	1.45m	kWh
187F0507	qp 2.5m ³ /h /130mm thread/DN20/G1B	PN16	High temp.	M-BUS	1.45m	kWh

¹ Cable length between flow sensor and calculator is 0.5m

² Cable length of M-BUS communication and temperature cable sensor

Sono 1100

Code No.	Flow Sensor ¹	Nominal Pressure	Cable Length ²	Module	Energy Unit	Cable Length ³
Heating Meters						
087G1040	qp 0.6m ³ /h /110mm thread/DN15/G¾B	PN16	1.5m	M-BUS	kWh	1.9m
087G1042	qp 1.5m ³ /h /110mm thread/DN15/G1B	PN16	1.5m	M-BUS	kWh	1.9m
087G1043	qp 1.5m ³ /h /130mm thread/DN20/G1B	PN16	1.5m	M-BUS	kWh	1.9m
087F1120	qp 3.5m ³ /h /260mm thread/DN25/G1¼B	PN16	1.5m		kWh	1.9m
187F1121	qp 6m ³ /h /260mm thread/DN25/G1¼B	PN16	1.5m		kWh	1.9m
087G1047	qp 6m ³ /h /260mm thread/DN32/G1½B	PN16	3m	M-BUS	kWh	2.9m
187F1123	qp 10m ³ /h /300mm thread/DN40/G2B	PN16	1.5m		MWh	1.9m
Cooling Meters - Heat & Cool						
087G1206	qp 0.6m ³ /h /110mm thread/DN15/G¾B	PN16	1.5m	M-BUS	kWh	1.9m
087G1207	qp 1.5m ³ /h /110mm thread/DN15/G¾B	PN16	1.5m	M-BUS	kWh	1.9m
087G1208	qp 2.5m ³ /h /130mm thread/DN20/G1B	PN16	1.5m	M-BUS	kWh	1.9m
187F1140	qp 3.5m ³ /h /260mm thread/DN25/G1¼B	PN16	1.5m		kWh	1.9m
187F1141	qp 6m ³ /h /260mm thread/DN32/G1½B	PN16	1.5m		kWh	1.9m
187F1143	qp 10m ³ /h /300mm thread/DN40/G2B	PN16	1.5m		MWh	1.9m
087F1145	qp 10m ³ /h /300mm flange/DN50	PN25	3m		MWh	2.9m
187F1146	qp 25m ³ /h /300mm flange/DN65	PN25	3m		MWh	2.9m
187F1147	qp 40m ³ /h /300mm flange/DN80	PN25	3m		MWh	2.9m
187F1148	qp 60m ³ /h /300mm flange/DN100	PN25	3m		MWh	2.9m

¹ Codes above have A-cell battery installed and are EN version heat/cool meters with 'low temperature' (return pipe) installation

² Cable length between calculator and flow sensor

³ Cable length of temperature sensor

Energy Meter Sizing Chart

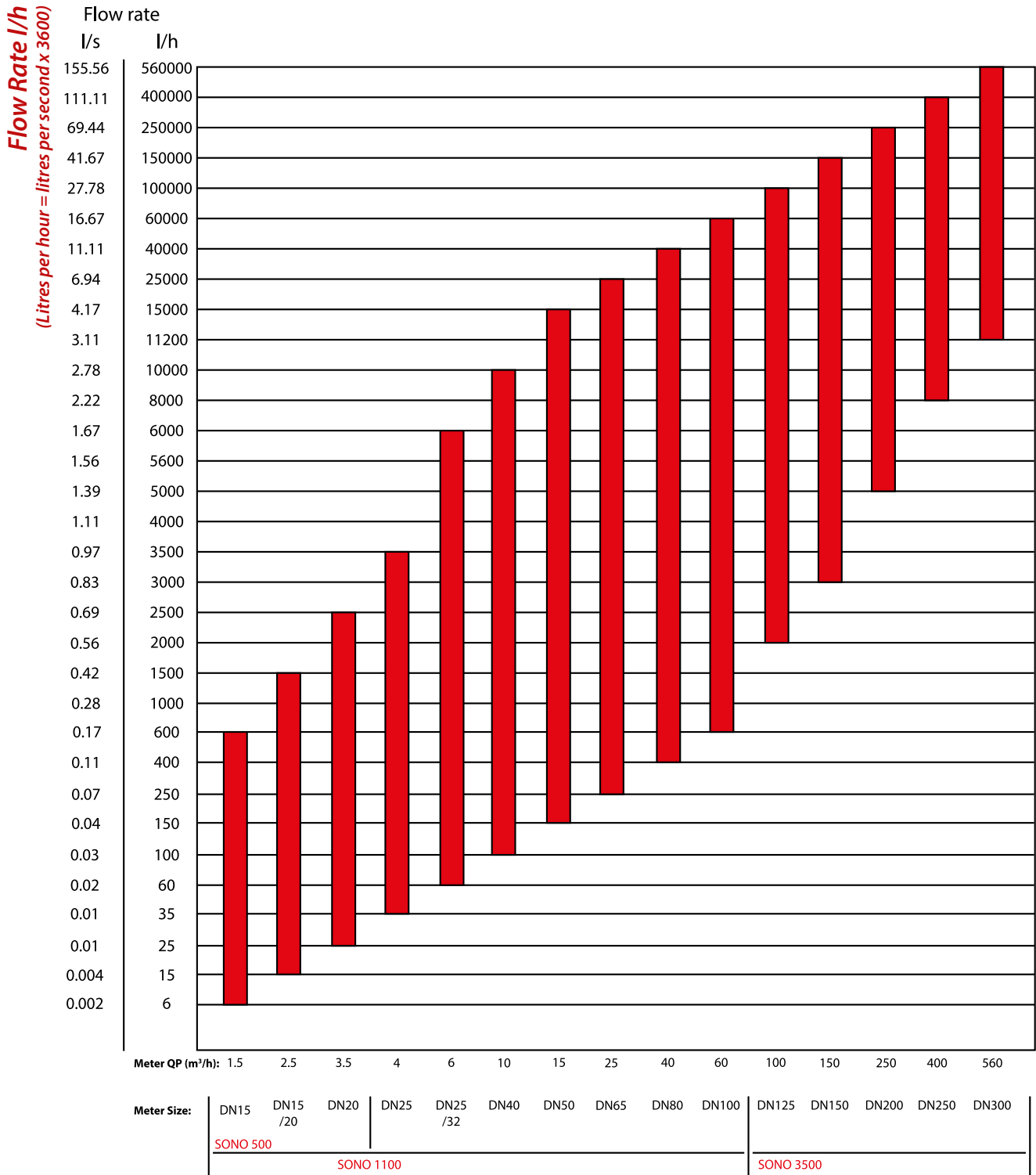

Ultrasonic Energy Meters and Calculators

Meter QP
Nominal Flow and Size DN

Sizing Method:

- Take the design maximum flow rate required for the meter
- Ensure it is in litres per hour (l/h = l/s x 3600, l/h = m³/h x 1000)
- Find your flow rate on the chart above
- Select the smallest meter to meet the required design flow rate



Butterfly and Check
Valves

Butterfly and Check Valves

Butterfly valves and check valves are the components that provide on/off regulation and backflow prevention within the district heating, HVAC or water applications where limited space is available for components.

Contents

Butterfly Valves	
VFY-LG.....	96
VFY-WH.....	97
VFY-LH.....	98
Check Valves	
NVD 402 and NVD 462.....	99
NVD 802, NVD 805 and NVD 895.....	100
NVD 812.....	101



Butterfly Valves

VFY-LG



- Spline driven one piece shaft connected to spherically machined disc allows high torque transmission i.e. quick response and minimum backlash
- Long term reliability due to upper and lower anti-friction bearings
- Safe maintenance: shaft blow out protection with circlip
- Position indicator

Technical Data	
Nominal Diameter (DN)	150-350
kvs valve (m ³ /h)	1212-8520
Rotation Angle	90°
Leakage Rate	Acc. to PED 97/23/CE, EN 12266-1, Rate A ¹⁾
Nominal Pressure (PN)	16
Medium	Circulation water, Glycolic water up to 50 % or drinking water
Medium temperature (°C)	-10 ... 120
Connection	Lug (Tapped lugs)
Mounting	Mounting deadline

Material	
Body	Cast iron EN GJL 250 (DIN GG25) DN 50-150 Ductile iron (DIN GGG40) DN 200-350
Disc	Ductile iron EN GJS 400-15 (DIN GGG 40) with Polyamide coating or Stainless Steel
Shaft	Stainless steel AISI 420
Liner	EPDM
Circlip	Steel XC 75 / Stainless steel
O-ring	Nitrile/Viton
Upper guide bush	Zinc coated S. + PTFE
Lower guide bush	Zinc coated S. + PTFE
Hear Box	Aluminium

¹⁾ No visible detectable leakage during the testing procedure

Type	DN (mm)	Kvs (m ³ /h)	Nominal Pressure	Weight (kg)	Code No.
Gear operated lugged lever butterfly valve with stainless steel disc					
VFY-LG	150	1212	PN16	10.7	065B746500
VFY-LG	200	2500	PN16	22.3	065B746600
VFY-LG	250	3948	PN16	28.8	065B746700
VFY-LG	300	5635	PN16	40.8	065B746800
VFY-LG	350	8520	PN16	49.1	065B746900
Gear operated lugged lever butterfly valve with polyamide coated disc					
VFY-LG	150	1212	PN16	18.34	065B737600
VFY-LG	200	2500	PN16	26.23	065B737700
VFY-LG	250	3948	PN16	35.8	065B737800
VFY-LG	300	5635	PN16	50.0	065B737900
VFY-LG	350	8500	PN16	48.4	065B745600

Butterfly Valves

VFY-WH



Technical Data

Nominal Diameter (DN)	25-300
kvs valve (m ³ /h)	40-5635
Rotation Angle	90°
Leakage Rate	Acc. to PED 97/23/CE, EN 12266-1, Rate A ¹⁾
Nominal Pressure (PN)	16 (from DN 32-300) / 10 (for DN 25)
Medium	Circulation water, Glycolic water up to 50 % or drinking water
Medium temperature (°C)	-10 ... 120
Connection	Wafer (centering lugs)
Mounting	Mounting between flanges

Material

Body	Cast iron EN GJL 250 (DIN GG25)
Disc	Ductile iron EN GJS 400-15 (DIN GGG 40) with Polyamide coating or Stainless Steel
Shaft	Stainless steel AISI 420
Liner	EPDM
Circlip	Steel XC 75 / Stainless steel
O-ring	Nitrile/Viton
Upper guide bush	Zinc coated S. + PTFE
Lower guide bush	Zinc coated S. + PTFE
Cap	EN GJS-400-15/EN GJL-250
Hand lever	EN GJS-400-15

¹⁾ No visible detectable leakage during the testing procedure

- Butterfly valve in 25mm-150mm
- Spline driven one piece shaft connected to spherically machined disc allows high torque transmission i.e. quick response and minimum backlash
- Long term reliability due to upper and lower anti-friction bearings
- Safe maintenance: shaft blow out protection with circlip
- Padlockable hand lever with 10 positions

Type	DN (mm)	Kvs (m ³ /h)	Nominal Pressure	Weight (kg)	Code No.
Hand operated wafer lever butterfly valve with stainless steel disc					
VFY-WH	25	40	PN10	2.63	065B735000
VFY-WH	32/40	62	PN16	2.61	065B735100
VFY-WH	50	79	PN16	3.25	065B741000
VFY-WH	65	174	PN16	3.7	065B741100
VFY-WH	80	275	PN16	4.0	065B741200
VFY-WH	100	496	PN16	6.3	065B741300
VFY-WH	125	883	PN16	7.7	065B741400
VFY-WH	150	1212	PN16	9.2	065B741500
Hand operated wafer lever butterfly valve with polyamide coated disc					
VFY-WH	50	79	PN16	3.3	065B735200
VFY-WH	65	174	PN16	3.7	065B735300
VFY-WH	80	275	PN16	4.0	065B735400
VFY-WH	100	496	PN16	6.99	065B735500
VFY-WH	125	883	PN16	7.57	065B735600
VFY-WH	150	1212	PN16	8.5	065B735700

Butterfly Valves

VFY-LH



- Butterfly valve in 25mm-150mm
- Spline driven one piece shaft connected to spherically machined disc allows high torque transmission i.e. quick response and minimum backlash
- Long term reliability due to upper and lower anti-friction bearings
- Safe maintenance : shaft blow out protection with circlip
- Padlockable hand lever with 10 positions

Technical Data	
Nominal Diameter (DN)	32-300
kvs valve (m ³ /h)	62-5635
Rotation Angle	90°
Leakage Rate	Acc. to PED 97/23/CE, EN 12266-1, Rate A ¹⁾
Nominal Pressure (PN)	16
Medium	Circulation water, Glycolic water up to 50 % or drinking water
Medium temperature (°C)	-10 ... 120
Connection	Lug (tapped lugs)
Mounting	Mounting between flanges or mounting deadline

Material	
Body	Cast iron EN GJL 250 (DIN GG25) DN 32-150 Ductile iron (DIN GGG40) DN 200-300
Disc	Ductile iron EN GJS 400-15 (DIN GGG 40) with Polyamide coating or Stainless Steel
Shaft	Stainless steel AISI 420
Liner	EPDM
Circlip	Steel XC 75 / Stainless steel
O-ring	Nitrile/Viton
Upper guide bush	Zinc coated S. + PTFE
Lower guide bush	Zinc coated S. + PTFE
Cap	EN GJS-400-15/EN GJL-250
Hand lever	EN GJS-400-15

¹⁾ No visible detectable leakage during the testing procedure

Type	DN (mm)	Kvs (m ³ /h)	Nominal Pressure	Weight (kg)	Code No.
Hand operated lugged lever butterfly valve with stainless steel disc					
VFY-LH	32	62	PN16	2.91	065B736500
VFY-LH	40	62	PN16	2.92	065B736600
VFY-LH	50	79	PN16	3.7	065B742000
VFY-LH	65	174	PN16	4.2	065B742100
VFY-LH	80	275	PN16	5.1	065B742200
VFY-LH	100	496	PN16	7.6	065B742300
VFY-LH	125	883	PN16	10.2	065B742400
VFY-LH	150	1212	PN16	11.7	065B742500
Hand operated lugged lever butterfly valve with polyamide coated disc					
VFY-LH	50	79	PN16	3.7	065B736700
VFY-LH	65	174	PN16	4.3	065B736800
VFY-LH	80	275	PN16	5.13	065B736900
VFY-LH	100	496	PN16	9.12	065B737000
VFY-LH	125	883	PN16	10.24	065B737100
VFY-LH	150	1212	PN16	11.18	065B737200

Check Valves

NVD 402 and 462



Technical Data	NVD 402	NVD 462
Nominal Diameter (DN)	40 - 500	50 - 200
kvs valve (m ³ /h)	47 - 6914	69 - 1031
Nominal Pressure (PN)	PN 16 (10)	
Medium	Circulation water, drinking water or chilled glycolic water up to 50%	
Medium temperature (°C)	- 10 ... 100°C	
Connection	Flanged connection	
Directive	Compliance with Pressure Equipment Directive 97/23/EC	
Design Standard	Flange drilling according to EN1092-2	Face-to-face dimensions according to EN558-1 14 series

Material	NVD 402	NVD 462
Casing DN 40-400	Cast iron / epoxy	Cast iron
Casing DN 500	Ductile iron / epoxy	
Ring seal DN 40-250	EPDM	
Ring	Bronze	
Spring	Stainless steel	
Seal	EPDM	
Closing system DN 40	Brass Bronze	Brass
DN 50-65		
DN 80-400 Stem Check Valve	Bronze Ductile iron / epoxy	Bronze
DN 500 Stem Check Valve	Bronze Ductile iron / epoxy	Bronze

Type	DN (mm)	Kvs (m ³ /h)	Nominal Pressure	Weight (kg)	Code No.
Flanged non-return valve - up to 100°C					
NVD 402	40	47	PN16	4.5	065B747000
NVD 462	50	69	PN16	6.7	065B748500
NVD 462	65	125	PN16	9.5	065B748600
NVD 462	80	157	PN16	11.0	065B748700
NVD 462	100	350	PN16	14.5	065B748800
NVD 462	125	582	PN16	21.0	065B748900
NVD 462	150	710	PN16	28.0	065B749000
NVD 462	200	1031	PN16	41.0	065B749100
NVD 402	250	2010	PN10	94.0	065B747800
NVD 402	300	2459	PN10	140.0	065B747900
NVD 402	350	2843	PN10	225.0	065B748000
NVD 402	400	4370	PN10	312.0	065B748100
NVD 402	500	6914	PN10	540.0	065B748200

NVD 402

- Operates in any position
- Minimum head loss
- Silent, reliable sealing, compact
- Exceptional robustness
- Notch provided for cable to submerged pumps until DN 100.
- Closing system : long back axial guiding for reduced displacement
- Sealing guaranteed by a flat seal
- Return spring

NVD 462

- Operates in any position
- Silent, reliable sealing, compact
- Exceptional robustness
- Notch provided for cable to submerged pumps up to DN 100
- Closing system : long back axial guiding
- Sealing guaranteed by O-ring.
- Return spring
- Body with integrated one-arm guide

Check Valves

NVD 802, 805 and 895



NVD 802

- Operating position : horizontal and vertical
- Easy to install and dismantle, space-saving
- Minimum head loss
- Does not generate hammering
- Closing system : disc with parabolic edges with return spring ; lateral guiding by 3 or 4 ribs (DN 32 to 100)
- Closing system with back axial guiding and return spring (DN 125 to 200).
- Metal/metal seal (machined trim)
- Using these check valves on networks equipped with piston pumps or compressors is not recommended.

NVD 895

- Operates in any position
- Silent, reliable sealing, compact
- Exceptional robustness
- Notch provided for cable to submerged pumps up to DN 100
- Closing system : long back axial guiding
- Sealing guaranteed by O-ring.
- Return spring
- Body with integrated one-arm guide

Technical Data	NVD 802	NVD 895	NVD 805
Nominal Diameter (DN)	32 - 40	50 - 400	450 - 600
kvs valve (m ³ /h)	18 - 28	35.7 - 5867	6547 - 11269
Nominal Pressure (PN)	PN 6/16	PN 10/16	PN 10/16
Medium	Circulation water, drinking water or chilled glycolic water up to 50%		
Medium temperature (°C)	- 10 ... 200°C		
Connection	Mounting between flanges		
Directive	Compliance with Pressure Equipment Directive 97/23/EC		
Design Standard	Flange drilling according to EN1092-2		

Material	NVD 802	NVD 895	NVD 805
Casing	DZR brass	Cast iron + epoxy Ductile iron + epoxy	Cast iron + epoxy
Closing system DN 40	Stainless steel		
Spring	Stainless steel	Stainless steel	Stainless steel
Stop guide	Stainless steel		
Plates		Stainless steel	Aluminium bronze
Seal		EPDM	NBR (nitrile)
Steam		Stainless steel	Stainless steel
Bearing		PTFE	PTFE
Eye bolt DN>150		Steel XC15	Steel XC15
Plugs		Brass	Brass

Code No.	Type	DN (mm)	Kvs (m ³ /h)	Nominal Pressure	Weight (kg)
Between flange non-return valve - DN32-50 up to 200°C, DN65-200 up to 100°C					
065B752000	NVD 802	32	18	PN16	0.4
065B752100	NVD 802	40	28	PN16	0.55
065B749500	NVD 895	50	35.7	PN16	1.5
065B749600	NVD 895	65	64.7	PN16	2.0
065B749700	NVD 895	80	116.1	PN16	3.0
065B749800	NVD 895	100	253.3	PN16	4.0
065B749900	NVD 895	125	481.8	PN16	6.0
065B750000	NVD 895	150	698.4	PN16	8.0
065B750100	NVD 895	200	1345.5	PN16	14.0
065B750200	NVD 895	250	2249.5	PN16	22.0
065B750300	NVD 895	300	3098	PN16	34.0
065B750400	NVD 895	400	5867	PN16	83.0
065B751600	NVD 805	450	6547	PN16	118
065B751700	NVD 805	500	7800	PN16	180
065B751800	NVD 805	600	11269	PN16	250

Check Valves

NVD 812



Technical Data	NVD 812
Nominal Diameter (DN)	15 - 200
kvs valve (m ³ /h)	4.24 - 546
Nominal Pressure (PN)	PN 25/40
Medium	Circulation water, drinking water or chilled glycolic water up to 50%
Medium temperature (°C)	- 10 ... 350°C
Leakage rate	According to EN12266-1 rate E
International Construction Standards	CE Conformity Directive 97/23/CE Connection according to ASA B16.1 class 125RF Connection according to ASA B16.5 class 150RF and 300RF Connection according to EN 1092.2 Overall dimensions according to EN558-1 series 49

Material	NVD 402
Casing	Stainless steel
Closing system	Stainless steel
Spring	Stainless steel
Spring	Stainless steel
Stop / Guide	Stainless steel
Centering collar	Stainless steel
Clips	Stainless steel
Discharge anti-static braid	Copper

Code No.	Type	DN (mm)	Kvs (m ³ /h)	Nominal Pressure	Weight (kg)
Between flange non-return valve - up to 350°C					
065B753000	NVD 812	15	4.24	PN40	0.1
065B753100	NVD 812	20	7.80	PN40	0.15
065B753200	NVD 812	25	12.40	PN40	0.25
065B753300	NVD 812	32	18.00	PN40	0.35
065B753400	NVD 812	40	28.00	PN40	0.55
065B753500	NVD 812	50	40.10	PN40	0.75
065B753600	NVD 812	65	72.50	PN40	1.55
065B753700	NVD 812	80	111.00	PN40	2.5
065B753800	NVD 812	100	182.00	PN40	3.5
065B753900	NVD 812	125	302.00	PN40	8.5
065B754000	NVD 812	150	370.00	PN40	13.0
065B754100	NVD 812	200	546.00	PN40	30.0

NVD 812

- Operates in any position
- Easy to install and dismantle, space-saving
- Minimum head loss
- Does not generate hammering
- Closing system: disc with parabolic edges with return spring and lateral guiding by 3 or 4 ribs (DN 15 to 100)
- Closing system with back axial guiding and return spring (ND 125 to 200).
- Metal/metal seal (machined trim)
- Using these check valves on networks equipped with piston pumps or compressors is not recommended.



Heat Exchangers

The same model of heat exchangers has been in use for over 40 years, without any significant developments. But now, owing to Danfoss' latest invention the Micro Plate Heat Exchanger (MPHE), all is about to change.

Thanks to a unique plate pattern design, our new MPHEs give you an excellent route to better performance and lower environmental impact. By improving the flow of fluid across the plate and utilisation of the surface area, MPHEs enable much better heat transfer.

The micro plate pattern also allows for greater flexibility in application design. Simply by varying the number, size and placement of dimples on the plate, MPHEs can be adapted to give the optimal heat transfer and minimal pressure drop in a variety of different applications - from district heating to solar heating solutions.



Contents

Brazed Micro Plate™ Heat Exchangers	104
Gasketed Micro Plate™ Heat Exchangers	105
Selection Chart - Heating Applications	106
Selection Chart - Cooling and DHW Applications	107
XB Range	108
Hexact Calculation Software	109

Micro Plate™ Technology (MPHE)

Compared to traditional heat exchangers, Micro Plate™ technology deliver exceptional performance, efficiency and flexibility.

For the first time, you can now create a system individually suited to your network by varying the number, size and placement of dimples, Micro Plates™ can be adapted for optimal heat transfer and minimal pressure drop.

Micro Plate™ Advantages

Up to 10% Enhanced Heat Transfer

MPHEs allow the fluid to move across the plate with a relatively uniform velocity. Between the fastest and slowest flowing areas, the difference is only x3, as opposed to x10 in older heat exchanger models. This improves the distribution of the mix fluid and enhances the heat transfer rate by up to 10%

Up to 35% Lower Pressure Loss

Thanks again to the unique plate design, the way that water is distributed inside the MPHE also reduces pressure loss. This means less energy is needed to drive the water around the system and consequently also lowers running costs.

Lower Carbon Footprint

By increasing the system's efficiency, less energy is required for the same result. The application can therefore be housed in a more compact design with fewer plates, so construction materials are kept to a minimum. Improved operational efficiency and a longer lifespan also help to reduce waste, all of which results in significant savings and a lower carbon footprint.

Brazed Micro Plate™ Heat Exchangers

Brazed Micro Plate™ heat exchangers are a revolutionary technology from Danfoss. Characterised by their unique pattern, our innovative new plate design out performs everything else on the market with significantly lower pressure loss and vastly improved heat transfer.

- Up to 10% enhanced heat transfer rate
- Up to 35% reduced pressure loss
- Substantial cost and energy savings
- More flexible and compact design

Embedded in our new range of brazed heat exchangers, Micro Plate™ technology is designed for smaller, lower duty applications with relatively constant pressures, temperatures and treated water supplies.

Higher efficiency

Lower pressure loss

Reduced pump power

Patented plate technology

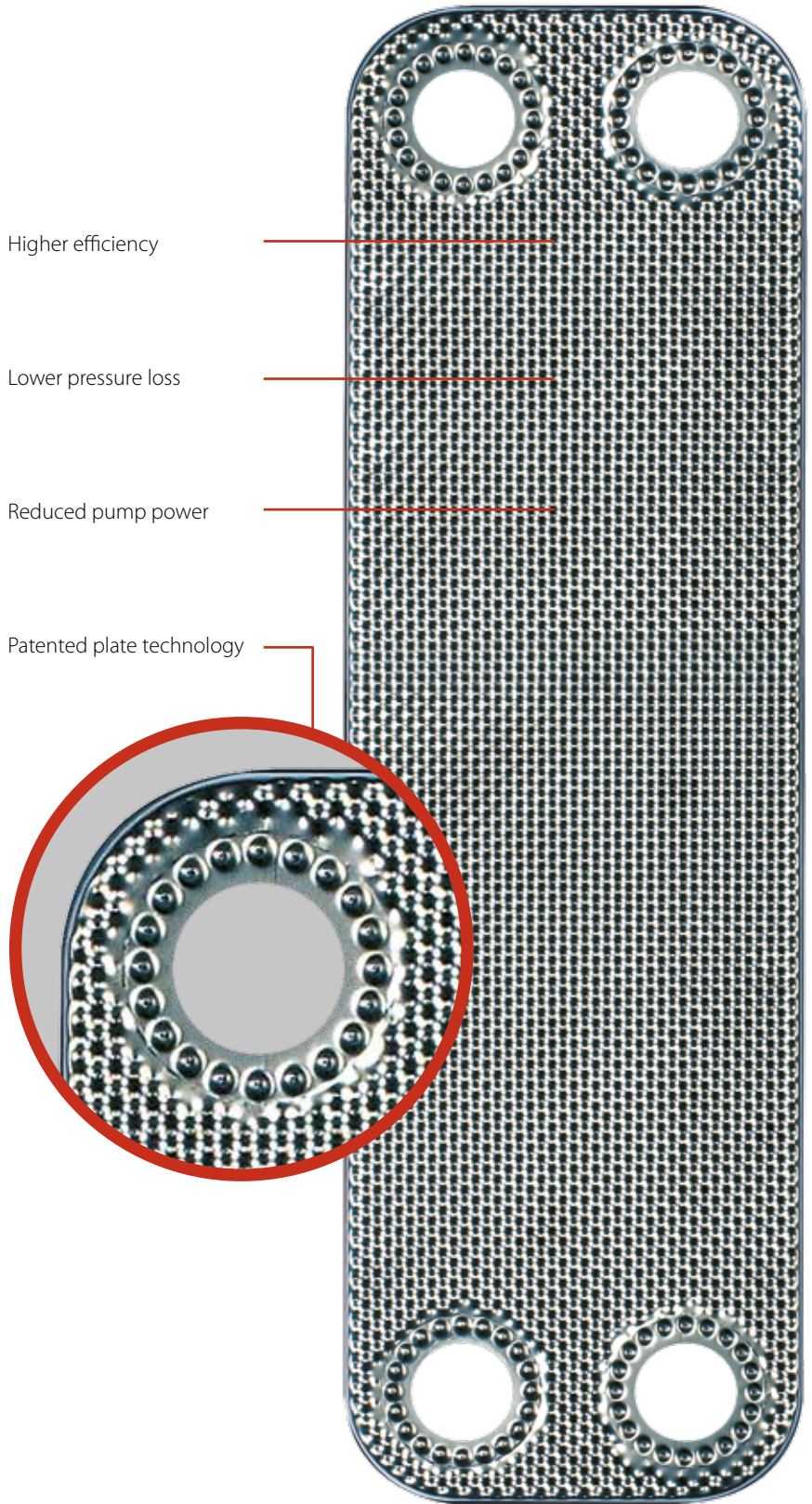

Gasketed Micro Plate™ Heat Exchangers

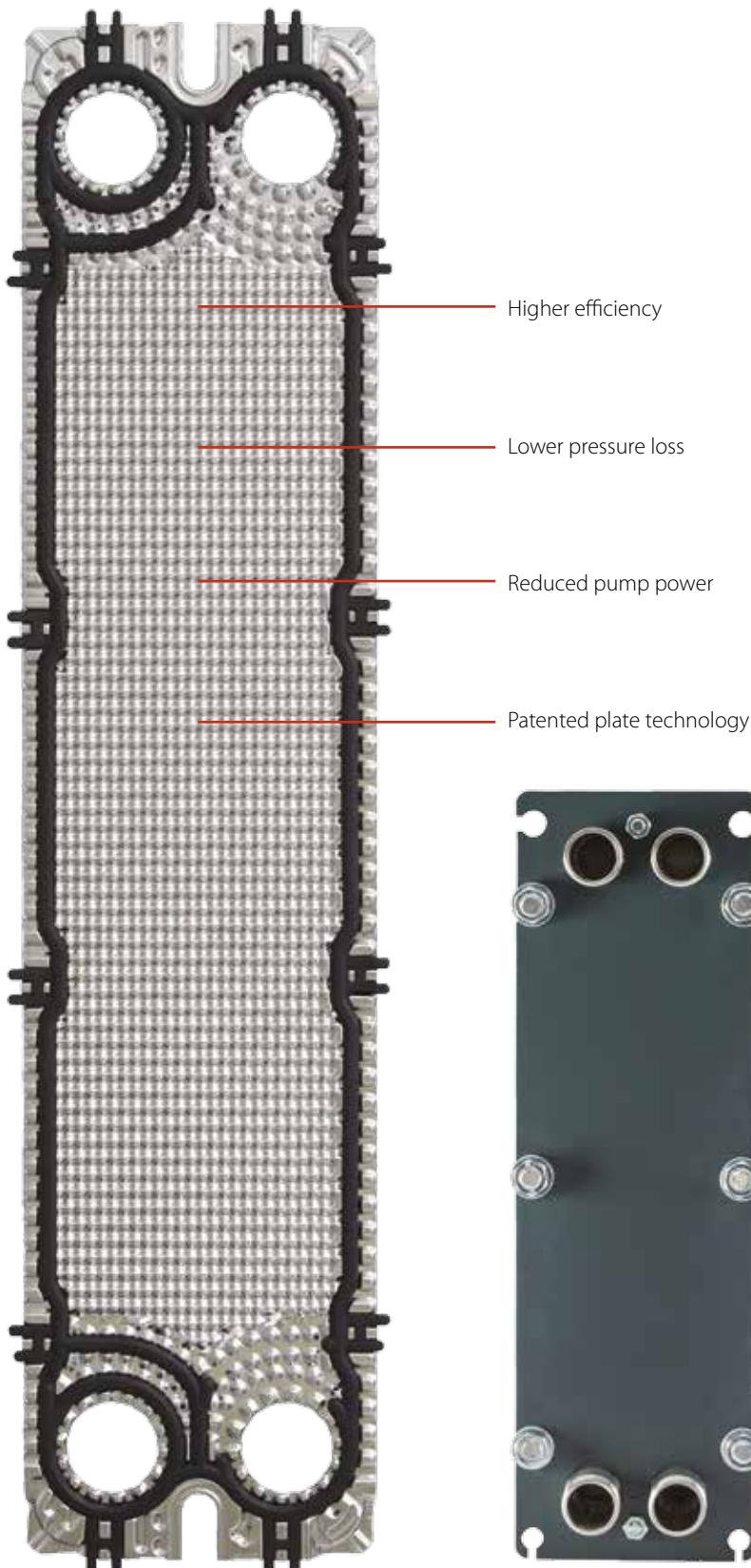

XGM - the right choice for your business.

The small but perfectly formed XGM032 is the ideal solution to keep your business profitable with superior performance and lower costs, compared to competitors' models.

- Enhanced heat transfer performance
- Compact size (only index 70-75% compared with next best alternatives)
- 1 frame = 3 plate corrugations = 3 x the performance
- Thread connection (G1A), with 72mm porthole distance
- Flow rates: Up to 20 m³/h
- NTU valve: 0.5 - 4.0

Micro Plate™ heat exchangers are a revolutionary technology from Danfoss. Characterised by their unique pattern, our innovative new plate design out performs everything else on the market with significantly lower pressure loss and vastly improved heat transfer.

- Up to 10% enhanced heat transfer rate
- Up to 35% reduced pressure loss
- Substantial cost and energy-savings
- More flexible and compact design

As part of our new range of gasketed heat exchangers, Micro Plate™ technology is designed for smaller, lower duty applications with relatively constant pressures, temperatures and treated water supplies. Typical heating systems include:

1. District heating and cooling
2. Decentralised heating systems
3. Biomass Micro Networks
4. Solar Combi systems
5. Instantaneous domestic hot water production

Heat Exchangers Selection Chart

Heating Application

Application:	Heating				Heating			
Type:	Heat Pumps/UFH				Radiators			
Primary Temperatures:	65/55 °C				80/60 °C			
Secondary Temperatures:	50/60°C				55/75 °C			
HEX Loss:	5 °C				5 °C			
	Type	HEX Code	Insulation Code	Fittings (x2)	Type	HEX Code	Insulation Code	Fittings (2x)
5 kW	XB06L-1-8	004B2024	004B1191	004B2947	XB06H+-1-8	004B1206	004B1191	004B2947
10 kW	XB06L-1-16	004B2026	004B1191	004B2947	XB06H+-1-16	004B1209	004B1191	004B2947
15 kW	XB06L-1-20	004B2027	004B1191	004B2947	XB06H+-1-20	004B1211	004B1191	004B2947
20 kW	XB12L-1-16	004H7526	004H4210	004H4205	XB12H-1-20	004H7557	004H4210	004H4205
25 kW	XB12L-1-20	004H7527	004H4210	004H4205	XB12H-1-26	004H7558	004H4210	004H4205
30 kW	XB12L-1-26	004H7528	004H4210	004H4205	XB12H-1-30	004H7559	004H4210	004H4205
35 kW	XB12L-1-26	004H7528	004H4210	004H4205	XB12H-1-36	004H7560	004H4210	004H4205
40 kW	XB12L-1-30	004H7529	004H4210	004H4205	XB12H-1-36	004H7560	004H4210	004H4205
50 kW	XB12L-1-36	004H7530	004H4210	004H4205	XB37M-1-26	004H7288	004B1721	004B2903
60 kW	XB12L-1-50	004H7532	004H4211	004H4206	XB37M-1-30	004H7289	004B1722	004B2903
75 kW	XB12L-1-60	004H7533	004H4211	004H4206	XB37M-1-36	004H7290	004B1722	004B2903
100 kW	XB12L-1-80	004H7535	004H4212	004H4206	XB37M-1-50	004H7292	004B1723	004B2903
125 kW	XB61L-SB-1-40	004B1908	004B1655	004B2908	XB61M-SB-1-36	004B1914	004B1655	004B2908
150 kW	XB61L-SB-1-50	004B1909	004B1655	004B2908	XB61M-SB-1-40	004B1915	004B1655	004B2908
200 kW	XB52M-1-80	004H4528	004B1935	004B2909	XB59M-1-60	004B1932	004B1652	004B2908
300 kW	XB52M-1-130	004H4533	004B1950	004B2909	XB59M-1-90	004B1936	004B1652	004B2908
500 kW	XB66L-1-110	004B1968	004B3543	Flanged	XB59M-1-160	004B1941	004B1654	004B2908

Application:	Heating				Heating			
Type:	Radiators				Radiators			
Primary Temperatures:	82/71°C				70/40 °C			
Secondary Temperatures:	66/77°C				35/65 °C			
HEX Loss:	5 °C				5 °C			
	Type	HEX Code	Insulation Code	Fittings (x2)	Type	HEX Code	Insulation Code	Fittings (2x)
5 kW	XB06L-1-8	004B2024	004B1191	004B2947	XB06H+-1-20	004B1211	004B1191	004B2947
10 kW	XB06L-1-16	004B2026	004B1191	004B2947	XB37H-1-10	004H7300	004B1721	004B2913
15 kW	XB06L-1-20	004B2027	004B1191	004B2947	XB37H-1-10	004H7300	004B1721	004B2913
20 kW	XB12L-1-16	004H7526	004H4210	004H4205	XB37H-1-16	004H7301	004B1721	004B2913
25 kW	XB12L-1-20	004H7527	004H4210	004H4205	XB37H-1-16	004H7301	004B1721	004B2913
30 kW	XB12L-1-26	004H7528	004H4210	004H4205	XB37H-1-16	004H7301	004B1721	004B2913
35 kW	XB12L-1-26	004H7528	004H4210	004H4205	XB37H-1-20	004H7302	004B1721	004B2903
40 kW	XB12L-1-30	004H7529	004H4210	004H4205	XB37H-1-26	004H7303	004B1721	004B2903
50 kW	XB12L-1-36	004H7530	004H4210	004H4205	XB37H-1-26	004H7303	004B1721	004B2903
60 kW	XB12L-1-40	004H7531	004H4211	004H4205	XB37H-1-36	004H7304	004B1722	004B2903
75 kW	XB12L-1-50	004H7532	004H4211	004H4206	XB37H-1-36	004H7304	004B1722	004B2903
100 kW	XB12L-1-70	004H7534	004H4211	004H4206	XB37H-1-50	004H7307	004B1722	004B2903
125 kW	XB61L-SB-1-36	004B1907	004B1655	004B2908	XB37H-1-60	004H7308	004B1723	004B2903
150 kW	XB61L-SB-1-50	004B1909	004B1655	004B2908	XB59M-1-40	004B1922	004B1651	004B2908
200 kW	XB52M-1-70	004H4527	004B1924	004B2909	XB59M-1-60	004B1932	004B1652	004B2909
300 kW	XB52M-1-120	004H4532	004B1950	004B2909	XB59M-1-80	004B1934	004B1652	004B2909
500 kW	XB66L-SB-1-90	004B1966	004B3543	Flanged	XB59M-1-140	004B1940	004B1653	004B2909

Heat Exchangers Selection Chart

Cooling and DHW Applications

Application:	Cooling			
Type:	Chillers/FCU			
Primary Temperatures:	6/12 °C			
Secondary Temperatures:	13/7 °C			
HEX Loss:	1 °C			
	Type	HEX Code	Insulation Code	Fittings (x2)
3 kW	XB37H-1-20	004H7302	004B1721	004B2913
5 kW	XB37H-1-30	004H7304	004B1721	004B2913
7 kW	XB37H-1-40	004H7306	004B1722	004B2913
10 kW	XB37H-1-60	004H7308	004B1723	004B2913
15 kW	XB37H-1-80	004H7310	004B1723	004B2913
20 kW	XB59M-1-70	004B1933	004B1652	004B2908
25 kW	XB59M-1-80	004B1934	004B1652	004B2908
30 kW	XB59M-1-100	004B1937	004B1652	004B2908
35 kW	XB59M-1-110	004B1938	004B1653	004B2908
50 kW	XB59M-1-160	004B1941	004B1654	004B2908

Application:	Cooling			
Type:	Chillers/FCU			
Primary Temperatures:	6/12 °C			
Secondary Temperatures:	14/8 °C			
HEX Loss:	1 °C			
	Type	HEX Code	Insulation Code	Fittings (x2)
75 kW	XB59M-1-80	004B1934	004B1652	004B2909
100 kW	XB59M-1-100	004B1937	004B1652	004B2909
125 kW	XB59M-1-140	004B1940	004B1653	004B2909
150 kW	XB59M-1-160	004B1941	004B1654	004B2909
200 kW	XB70M-1-80	004B2003	004B2550	Flanged
300 kW	XB70M-1-120	004B2007	004B2570	Flanged

Application:	DHW				DHW			
Type:	Instant DHW				Instant DHW			
Primary Temperatures:	80/20 °C				80/20 °C			
Secondary Temperatures:	10/50 °C				10/60 °C			
	Type	HEX Code	Insulation Code	Fittings (x2)	Type	Code	Insulation Code	Fittings (2x)
30 kW	XB06H-1-16	004B2038	004B1191	004B2947	XB06H+-1-26	004B1212	004B1191	004B2947
35 kW	XB06H-1-20	004B2039	004B1191	004B2947	XB06H+-1-20	004B1211	004B1191	004B2947
40 kW	XB06H-1-20	004B2039	004B1191	004B2947	XB06H+-1-20	004B1211	004B1191	004B2947
50 kW	XB06H-1-26	004B2041	004B1191	004B2947	XB06H+-1-26	004B1212	004B1191	004B2947
55 kW	XB12H-1-20	004H7557	004H4210	004H4205	XB06H+-1-30	004B1214	004B1192	004B2947
60 kW	XB12H-1-20	004H7557	004H4210	004H4205	XB37H-1-16	004H7301	004B1721	004B2913
75 kW	XB12H-1-20	004H7557	004H4210	004H4205	XB37H-1-20	004H7302	004B1721	004B2913
90 kW	XB12H-1-30	004H7559	004H4210	004H4205	XB37H-1-26	004H7303	004B1721	004B2913
100 kW	XB12H-1-36	004H7560	004H4210	004H4206	XB37H-1-26	004H7303	004B1721	004B2913
125 kW	XB12H-1-50	004H7562	004H4210	004H4206	XB37H-1-36	004H7305	004B1722	004B2903
150 kW	XB12H-1-50	004H7562	004H4210	004H4206	XB37H-1-40	004H7306	004B1722	004B2903
250 kW	XB52M-1-26	004H4521	004B1924	004B2909	XB37H-1-50	004H7292	004B1723	004B2903
500 kW	XB52M-1-50	004H4525	004B1924	004B2909	XB59M-1-60	004B1932	004B1652	004B2909

Please note: These charts are for guidance only. Please check your selection with Danfoss prior to ordering a heat exchanger.

The pressure drop used in calculating the heat exchangers is 20kPa maximum

For selections outside of this criteria please contact martyn_neil@danfoss.com

Heat Exchangers

XB Range

The XB series is a range of copper brazed plate heat exchangers for use in District Heating (DH) and District Cooling (DC) applications that offer a compact design and excellent heat transfer properties.

XB06 - Compact performance

The small XB06 copper brazed stainless steel heat exchanger with one pass is designed for district heating systems with varying differential pressure and where high idle temperature is required.

XB37 - Exceptional efficiency

The XB37 copper brazed stainless steel heat exchanger comes in a larger size than the XB06, giving you even greater application flexibility with the same high system efficiency and excellent heat transfer properties.

XB70 - Compact design with excellent performance

The XB70 is the largest copper brazed stainless steel heat exchanger in the range, thanks to its compact design and excellent heat transfer properties, it is ideal for heating and domestic hot water applications, and also suitable for HVAC, cooling and industrial applications.

Type	Connection size (DN)	Connection type	Width (mm)	Length (mm)	Max Design Pressure (bar)	Max working temperature (°C)
XB 06	¾"	Thread	95	320	25	180
XB 20	1"	Thread	118	338		
XB 37	1"	Thread	119	525		
XB 59	2"	Thread	188	613		
XB 61	2"	Thread + Flange	243	525		
XB 70	65/100	Flange	365	991	25/16	



Find the perfect match with 2nd generation Hexact



heatexchangers

Hexact

The accurate timesaver from Danfoss

Save yourself time, trouble and money: use our new Hexact software to choose your heat exchangers. Hexact gives you an immediate solution for your application, with an intuitive interface and smart algorithms that mean you can start saving within minutes. Download it now and try it for yourself.

Go to download page Version 1.5.6

All about Hexact

The software works smoothly and accurately with our innovative Micro Plate Heat Exchangers (MPHEs) as well as our traditional Braze Plate Heat Exchangers (BPHEs). To find the optimal heat exchanger for your needs, simply enter your application data. The software responds immediately with our recommended MPHE or BPHE product.

Features

Easy to use
Instant calculations for BPHEs and MPHEs
Based on verified laboratory data
All types of condenser and evaporator calculations
Application based models

"Very easy to use"

"Best software yet"

- Quick and easy to use
- Define your own profile, including temperature and pressure, connection sizes/types, delivery options and more
- Wide range of print options, including datasheets, drawings, punch lists, BOM and Tender Text.

Now in its user-friendly second generation, Hexact makes it faster and easier than ever to find the right Danfoss heat exchanger for you needs.

Our intelligent software will help you to discover the most appropriate and competitive solution for your district heating applications and network. A range of new features mean you can order tailor-made heat exchangers, control order handling and even print out tender documentation.

Simply follow the step-by-step guide and Hexact does the rest.

Start saving energy today at:
www.hexact.danfoss.com



Danfoss/Trend Cross Reference

Plant and Steam Valves

Trend Code	Danfoss Product Type	Danfoss Part Number	Trend code	Danfoss Product Type	Danfoss Part Number
Plant Valves - Screwed Internal Brass			Plant Valves - Flanged		
VG2N/15/0.6	VRB2 15/0.63 internal	065Z023100	VC2/15/0.63	VF2 15/0.63 ⁽²⁾	065Z027100
VG2N/15/1.0	VRB2 15/1.0 internal	065Z023200	VC2/15/1.0	VF2 15/1.0 ⁽²⁾	065Z027200
VG2N/15/1.6	VRB2 15/1.6 internal	065Z023300	VC2/15/1.6	VF2 15/1.6 ⁽²⁾	065Z027300
VG2N/15/2.5	VRB2 15/2.5 internal	065Z023400	VC2/15/2.5	VF2 15/2.5 ⁽²⁾	065Z027400
VG2N/15/4.0	VRB2 15/4.0 internal	065Z023500	VC2/15/4.0	VF2 15/4.0 ⁽²⁾	065Z027500
VG2N/20/6.3	VRB2 20/6.3 internal	065Z023600	VC2/20/6.3	VF2 20/6.3 ⁽²⁾	065Z027600
VG2N/25/10	VRB2 25/10 internal	065Z023700	VC2/25/10	VF2 25/10 ⁽²⁾	065Z027700
VG2N/32/16	VRB2 32/16 internal	065Z023800	VC2/32/16	VF2 32/16 ⁽²⁾	065Z027800
VG2N/40/25	VRB2 40/25 internal	065Z023900	VC2/40/25	VF2 40/25 ⁽²⁾	065Z027900
VG2N/50/40	VRB2 50/40 internal	065Z024000	VC2/50/40	VF2 50/40 ⁽²⁾	065Z028000
VG3N/15/0.6	VRB3 15/0.63 internal	065Z021100	VC2/65/63	VF2 65/63 ⁽³⁾	065Z028100
VG3N/15/1.0	VRB3 15/1.0 internal	065Z021200	VC2/80/100	VF2 80/100 ⁽³⁾	065Z028200
VG3N/15/1.6	VRB3 15/1.6 internal	065Z021300	VC2/100/145	VF2 100/145	065B320500
VG3N/15/2.5	VRB3 15/2.5 internal	065Z021400	VC2/125/220	VF2 125/220	065B323000
VG3N/15/4.0	VRB3 15/4.0 internal	065Z021500	VC2/150/320	VF2 150/320	065B325500
VG3N/20/6.3	VRB3 20/6.3 internal	065Z021600	VC3/15/0.63	VF3 15/0.63 ⁽²⁾	065Z025100
VG3N/25/10	VRB3 25/10 internal	065Z021700	VC3/15/1.0	VF3 15/1.0 ⁽²⁾	065Z025200
VG3N/32/16	VRB3 32/16 internal	065Z021800	VC3/15/1.6	VF3 15/1.6 ⁽²⁾	065Z025300
VG3N/40/25	VRB3 40/25 internal	065Z021900	VC3/15/2.5	VF3 15/2.5 ⁽²⁾	065Z025400
VG3N/50/40	VRB3 50/40 internal	065Z022000	VC3/15/4.0	VF3 15/4.0 ⁽²⁾	065Z025500
			VC3/20/6.3	VF3 20/6.3 ⁽²⁾	065Z025600
			VC3/25/10	VF3 25/10 ⁽²⁾	065Z025700
Plant Valves - Screwed External Brass					
VG2X/15/0.6	VRB2 15/0.63 external	065Z017101	VC3/32/16	VF3 32/16 ⁽²⁾	065Z025800
VG2X/15/1.0	VRB2 15/1.0 external	065Z017201	VC3/40/25	VF3 40/25 ⁽²⁾	065Z025900
VG2X/15/1.6	VRB2 15/1.6 external	065Z017301	VC3/50/40	VF3 50/40 ⁽²⁾	065Z026000
VG2X/15/2.5	VRB2 15/2.5 external	065Z017401	VC3/65/63	VF3 65/63 ⁽³⁾	065Z026100
VG2X/15/4.0	VRB2 15/4.0 external	065Z017501	VC3/80/100	VF3 80/100 ⁽³⁾	065Z026200
VG2X/20/6.3	VRB2 20/6.3 external	065Z017601	VC3/100/145	VF3 100/145	065B168500
VG2X/25/10	VRB2 25/10 external	065Z017701	VC3/125/220	VF3 125/220	065B312500
VG2X/32/16	VRB2 32/16 external	065Z017801	VC3/150/320	VF3 150/320	065B315000
VG2X/40/25	VRB2 40/25 external	065Z017901			
VG2X/50/40	VRB2 50/40 external	065Z018001	Plant Valves - Flanged Steam		
VG3X/15/0.6	VRB3 15/0.63 external	065Z015101	VC2H/15/0.4 LOG	VFS2 15/0.4	065B151000
VG3X/15/1.0	VRB3 15/1.0 external	065Z015201	VC2H/15/0.63 LOG	VFS2 15/0.63	065B151100
VG3X/15/1.6	VRB3 15/1.6 external	065Z015301	VC2H/15/1.0 LOG	VFS2 15/1.0	065B151200
VG3X/15/2.5	VRB3 15/2.5 external	065Z015401	VC2H/15/1.6 LOG	VFS2 15/1.6	065B151300
VG3X/15/4.0	VRB3 15/4.0 external	065Z015501	VC2H/15/2.5 LOG	VFS2 15/2.5	065B151400
VG3X/20/6.3	VRB3 20/6.3 external	065Z015601	VC2H/15/4.0 LOG	VFS2 15/4.0	065B151500
VG3X/25/10	VRB3 25/10 external	065Z015701	VC2H/20/6.3 LOG	VFS2 20/6.3	065B152000
VG3X/32/16	VRB3 32/16 external	065Z015801	VC2H/25/10 LOG	VFS2 25/10	065B152500
VG3X/40/25	VRB3 40/25 external	065Z015901	VC2H/32/16 LOG	VFS2 32/16	065B153200
VG3X/50/40	VRB3 50/40 external	065Z016001	VC2H/40/25 LOG	VFS2 40/25	065B154000
			VC2H/50/40 LOG	VFS2 50/40	065B155000
			VC2H/65/63 LOG	VFS2 65/63	065B336500
			VC2H/80/100 LOG	VFS2 80/100	065B338000
			VC2H/100/145 LOG	VFS2 100/145	065B340000

Danfoss/Trend Cross Reference Actuators and Fan Coil Valves

Trend Code	Danfoss Product Type	Danfoss Part Number	Trend Code	Danfoss Product Type	Danfoss Part Number
Actuators			Fan Coil Valves - Flat Short Stroke		
AT103/24	TWA-Z	082F126200	SVB2/15/0.25/F	VZL2 DN 15/0.25	065Z207000
ATR103/24-NC	TWA-A 24V AC/DC NC	088H311100	SVB2/15/0.4/F	VZL2 DN 15/0.4	065Z207100
ATR103/24-NO	TWA-A 24V AC/DC NO	088H311000	SVB2/15/0.6/F	VZL2 DN 15/0.6	065Z207200
A203/230	AMV 130 230V	082H803700	SVB2/15/1.0/F	VZL2 DN 15/1.0	065Z207300
A203/230/K	AMV 130-H 230V	082H804100	SVB2/15/1.6/F	VZL2 DN 15/1.6	065Z207400
A203/24	AMV 130 24V	082H803600	SVB2/20/2.5/F	VZL2 DN 20/2.5	065Z207500
A203/24/K	AMV 130-H 24V	082H804000	SVB2/20/3.5/F	VZL2 DN 20/3.5	065Z207600
A203/P	AME 130 24V	082H804400	SVB3/15/0.25/F	VZL4 DN 15/0.25	065Z209000
A203/P/K	AME 130-H 24V	082H804600	SVB3/15/0.4/F	VZL4 DN 15/0.4	065Z209100
A204/230	AMV 140 230V	082H803900	SVB3/15/0.6/F	VZL4 DN 15/0.6	065Z209200
A204/230/K	AMV 140-H 230V	082H804300	SVB3/15/1.0/F	VZL4 DN 15/1.0	065Z209300
A204/24	AMV 140 24V	082H803800	SVB3/15/1.6/F	VZL4 DN 15/1.6	065Z209400
A204/24/K	AMV 140-H 24V	082H804200	SVB3/20/2.5/F	VZL4 DN 20/2.5	065Z209500
A204/P	AME 140 24V	082H804700	SVB3/20/3.5/F	VZL4 DN 20/3.5	065Z209600
A204/P/K	AME 140-H 24V	082H804500	SVB4/15/0.25/F	VZL4 DN 15/0.25	065Z209000
A301/230	AMV 435 230V	082H016300	SVB4/15/0.4/F	VZL4 DN 15/0.4	065Z209100
A301/24	AMV 435 24V	082H016200	SVB4/15/0.6/F	VZL4 DN 15/0.6	065Z209200
A301/P	AME 435 24V	082H016100	SVB4/15/1.0/F	VZL4 DN 15/1.0	065Z209300
A302/230	AMV 435 230V	082H016300	SVB4/15/1.6/F	VZL4 DN 15/1.6	065Z209400
A302/24	AMV 435- 24V	082H016200	SVB4/20/2.5/F	VZL4 DN 20/2.5	065Z209500
A302/P	AME 435 24V	082H016100	SVB4/20/3.5/F	VZL4 DN 20/3.5	065Z209600
A401/230	AMV 435 230V	082H016300			
A401/24	AMV 435 24V	082H016200			
A401/P	AME 435 24V	082H016100			
A402/230	AMV 435 230V	082H016300			
A402/24	AMV 435 24V	082H016200			
A402/P	AME 435 24V	082H016100			
A501/230	AMV 55 230V	082H302100			
A501/24	AMV 55 24V	082H302000			
A501/P	AME 55 24V	082H302200			
A502/230	AMV 56 230V	082H302400			
A502/24	AMV 56 24V	082H302300			
A502/P	AME 56 24V	082H302500			
A601/230	AMV 85 230V	082G145100			
A601/24	AMV 85 24V	082G145000			
A601/P	AME 85 24V	082G145200			
A602/230	AMV 86 230V	082G146100			
A602/24	AMV 86 24V	082G146000			
A602/P	AME 86 24V	082G146200			
Actuators - Spring Return					
A353/2/230	AMV 13 230V SU	082H304200			
A353/2/24	AMV 13 24V SU	082H304300			
A353/2/P	AME 13 24V SU	082H304400			
A451/1/230	AMV 25SD 230V	082H303700			
A451/1/24	AMV 25SD 24V	082H303600			
A451/1/P	AME 25SD	082H303800			
A451/2/230	AMV 438SU 230V	082H012300			
A451/2/24	AMV 438SU 24V	082H012200			
A451/2/P	AME 438SU	082H012100			
Fan Coil Valves - Compression Short Stroke					
SVB2/15/0.25	VZL2 DN 15/0.25	065Z204000			
SVB2/15/0.4	VZL2 DN 15/0.4	065Z204100			
SVB2/15/0.6	VZL2 DN 15/0.6	065Z204200			
SVB2/15/1.0	VZL2 DN 15/1.0	065Z204300			
SVB2/15/1.6	VZL2 DN 15/1.6	065Z204400			
SVB2/20/2.5	VZL2 DN 20/2.5	065Z204500			
SVB2/20/3.5	VZL2 DN 20/3.5	065Z204600			
SVB4/15/0.25	VZL4 DN 15/0.25	065Z206000			
SVB4/15/0.4	VZL4 DN 15/0.4	065Z206100			
SVB4/15/0.6	VZL4 DN 15/0.6	065Z206200			
SVB4/15/1.0	VZL4 DN 15/1.0	065Z206300			
SVB4/15/1.6	VZL4 DN 15/1.6	065Z206400			
SVB4/20/2.5	VZL4 DN 20/2.5	065Z206500			
SVB4/20/3.5	VZL4 DN 20/3.5	065Z206600			

ENGINEERING
TOMORROW

Danfoss

Danfoss Ltd

Amphill Road, Bedford, MK42 9ER
Tel: 01234 364621
Fax: 01234 219705
Email: ukheating@danfoss.com
Website: www.heating.danfoss.co.uk

Danfoss can accept no responsibility for possible errors in catalogues, brochures, and other printed material. Danfoss reserves the right to alter its products without notice. This also applies to products already on order provided that such alterations can be made without subsequent changes being necessary in specifications already agreed. All trademarks in this material are property of the respective companies. Danfoss and the Danfoss logotype are trademarks of Danfoss A/S. All rights reserved.
