



EXCLUSIVE

SPIDER LIFTS AT A HIGHER LEVEL FOR 40 YEARS

FS 230 *Sigma*
FS 76 *Sigma*





The ultimate compact platform

The Falcon Sigma has an extremely versatile boom configuration and machine compactness which make the Falcon Sigma models the best choice for maintainers, pruners, installers and hires.

- Facility management
- Atrium access
- Narrow access
- Tree care
- Best quality & safety
- Easy transport & propelling
- Low weight & ground pressure
- Flexible outrigger setting
- Limited setup space
- Power - Bi-energy Hybrid

The Falcon Sigma Lift is capable of passing through a door opening a mere 0,8 m (2'7") wide and 2 m (6'6") high. Further details on the Falcon FS 230/ FS76 Sigma is mentioned on the following pages.

USM ReRents

909 South Route 83
Suite 200
Elmhurst, IL 60126
630.530.8550

usmrents.com



Model:

FS 230 Sigma

FS 76 Sigma

Metric

US

Working height:
Maximum reach:

23 m
12,0 m

75'6"
39'4"

Basket load:
Aluminium basket:
Turret rotation:

200 kg
130x70x110 m
+320° / -320°

440 lbs
4'3"x2'4"x3'7"
+320° / -320°

Dimensions (transport position)

Total height:
Total length:
Total width:
Gradability:
Weight approx.:

2,0 m
5,337 m
0,78 m
31%
2900 kg*

6'7"
17'6"
2'7"
31%
6380 lbs*

*Depending on optional equipment

FS 230 Sigma
FS 76 Sigma

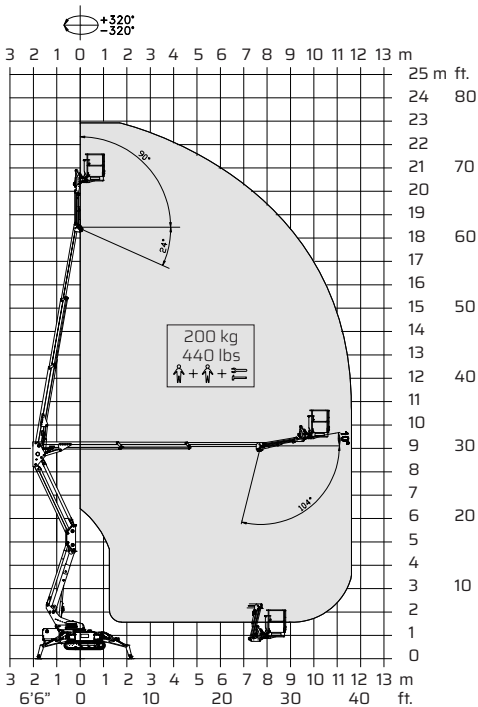

Working height and reach.



909 South Route 83
Elmhurst IL 60126

630.530.8550

salesteam@usmrents.com

usmrents.com



STANDARD EQUIPMENT:

- Articulated boom (two elements)
- Telescopic boom (main boom + 2 extensions)
- Jib
- $\pm 320^\circ$ turret rotation
- Engine start and stop controls from basket
- Basket with aluminium guardrails
- Automatic basket levelling
- Basket load sensing device
- 4 hydraulic outriggers
- 110/230 V AC power supply in basket
- Gradability approximately 31°
- Drive speed max 2 Km/h (1,25 mph)
- Wireless remote control
- 110/230 V 1,5 kW motor
- Flexible outrigger settings
- Hour meter
- Standard boom colours Grey (RAL 7035) and chassis Blue (RAL5002)
- EN 280:2013 CE Certified

Available with one of the following engines:

- Diesel (Kubota)

Or Lithium version

- Lithium batteries 48V 300 Ah (FS230E/FS76E)

OPTIONS:

- 180° basket rotation
- Dust Cover for Storage
- Special colour
- Anti entrapment device
- Non-marking crawlers
- Air/water in basket

USM ReRents

Exclusive Falcon Lifts Representation for North America

New Sales - Rental - Service - Parts

We Only Rent to Rental Companies

630.530.8550 usmrents.com