

SUMMARY

SERVO BRUSHLESS PRODUCTS	3
<i>SCS DIGITAL DRIVES INTRO</i>	4
CVS_{II}	
DIGITAL SERVO DRIVE FOR SINUSOIDAL BRUSHLESS MOTORS	8
DC DRIVE PRODUCTS	10
FULL CONTROLLED	
CT38	
2/4 QUADRANT FULL CONTROLLED THREE-PHASE DRIVES FOR D.C. MOTORS - SERIES CT	12
CM38	
4 QUADRANT FULL CONTROLLED SINGLE PHASE DRIVES FOR D.C. MOTORS - SERIES CM	15
CM220-TR	
4-QUADRANT SCR BIDIRECTIONAL FULL CONTROLLED SINGLE-PHASE CONVERTER	17
HALF CONTROLLED	
CM22	
HALF-CONTROLLED SINGLE PHASE CONVERTER	20
CM 220-9S	
UNIDIRECTIONAL SINGLE-PHASE HALF-CONTROLLER CONVERTER (1 QUADRANT)	22
DC SERVO DRIVES	
CH220 - CH22	
UNIDIRECTIONAL MOSFET DRIVE	25
ST	
EUROCARD E1 ST SERIES TRANSISTOR PWM SERVO AMPLIFIER FOR D.C. MOTORS	27
SM	
EUROCARD E1 SERIES MOSFET PWM SERVO AMPLIFIERS FOR D.C. MOTORS	30
PHASE SHIFTERS	
PM22	
FULL-WAVE PHASE CONTROL CHARACTERISTICS	34
PS380	
FULL-WAVE PHASE CONTROL CHARACTERISTICS	36

LINE-SIDE PRODUCTS

38

DCB

3 PHASE HALF CONTROLLED LINE MODULE FOR DC-BUS APPLICATION

40

UFS

BRAKING UNIT FOR FREQUENCY INVERTERS AND CONVERTERS

42

RUFC

BRAKING RESISTORS

44

LT

LINE INDUCTANCES

45

RF

EMC FILTERS FOR INVERTERS AND CONVERTERS

45

SERVO BRUSHLESS PRODUCTS

SERVO DRIVES PRODUCTS family offers to our customers deep reliability, maximum flexibility and highest performances in a wide range of motion control applications.

SCS has been designing and producing servo drives for more than 30 years, this is the base of our customers and partners trust in our deep knowledge and high service level.

SCS drives are designed to offer to our customers the maximum reliability, flexibility and customization: tailoring our product on your application is our first aim.

That's why **SCS** can

Drive your Solutions to Success.



If you need to **drive easy and safe**, **SCS** is the right partner for you.

SCS DIGITAL DRIVES

MOTION CONTROL: OUR WAY

Digital Servo Drives represents the key point of SCS in customer oriented solutions.

The three main issues of the product family are flexibility, connectivity and technical support.

Flexibility means bringing to the machine designer the maximum degree of customization in terms of functionalities and product configuration.

Connectivity means allowing the possibility of integrating the product in any of the existing fieldbus network.

Technical Support means being a valuable help for our customers in design, startup and maintenance phases thanks to a professional and reliable service made of a thirty-years experience and know-how in industrial and process automation fields.

SCS servo drives allow you to easily realize any application in speed control, torque control or position tracking.

It is possible furthermore to customise the CVS thanks to a line of modules and technological options.

Expansion of I/O on board, dedicated application integrated from SCS into the drive, connection to main existing fieldbus and use of advanced positioning transducers (i.e. from absolute SSI encoder to sensorless mode) are available just for your purposes.

WideLoop control, designed by SCS, integrates in a single loop all of the typical servo drive control modes so that you can surf between them simply using the correspondent commands without modifying the drive parameters.

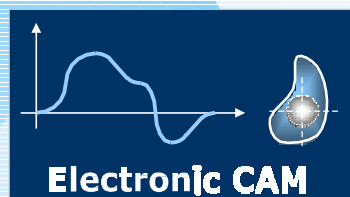
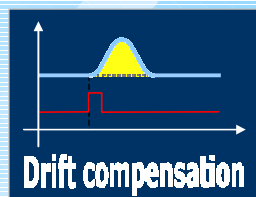
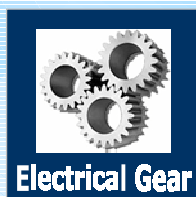
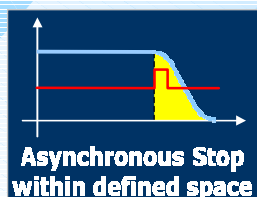
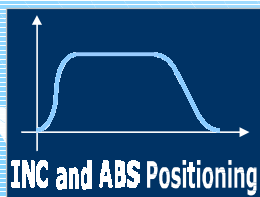

SOLUTION ORIENTED FEATURES

You can design positioning applications without any difficulty thanks to many integrated specific functions such as automatic homing, incremental or absolute positioning, even using an external encoder on your load as position feedback (for backlash or slip compensation).

SCS servo drives includes a set of functional features that allows to distribute the management of the application on the axes with a remarkable facilitation of the main control software of your machines.

The possibility of a separate power supply for logic and power sections allows to maintain an active control (I/O, position's counters, encoder simulator, communication) even in case of emergency or power supply's lack.

All of the available I/O can be indexed: it is possible to select and address the Inputs (commands) and the Output (monitors) and adapt them your applications needs.

You can store and select up to 4 parameters sets: you can change the drive configuration while passing through

your application operation modes and you can simplify the spare parts management by inserting at the same time the configurations used in your machines for different axes.

WideLoop will allow you to use the "Stop in the Space" function even while working in speed control mode or in electrical gearing mode. In such manner it is possible to easily design an assembling application with discontinuous input feed.

Furthermore is possible to move to a preset position an axes (absolute positioning) even while it is working in electrical gear control mode.

This is why you can quickly realize a simple "flying cut" application using **SCS** servo drives.

It is possible to download an updated or customised firmware for the drives so that you can manage your application maintenance or, thanks to SCS's support, leading an "on-site testing" activity in case of complex startup or commissioning issues.

DRIVE CONFIGURATOR

SCS developed **ScsComm**, a PC application to configure and manage all of the features of the servo drive product family.

The user can easily configure your drive changing a single parameter or loading, saving or restoring a complete set of parameters in order to satisfy your application needs.

The I/O configuration can also be performed in a very easy way using the I/O Mapping window.

The startup and maintenance of your application has never been so easy: you can read all the measures you need and you can monitor the speed, current, status and any of the monitors of the drive control, the motor and the environment of your application.

In addition both the status and the alarms can be read and analyzed so that the troubleshooting of your application is made easier than ever.

ScsComm includes dedicated plugins to expand your analysis and debugging power and to manage special features or custom applications.

In fact you can use the integrated digital oscilloscope to trace all of the monitors you need.

You can use the integrated **Cam Builder** in order to easily and quickly design, test and download to the drive the electronic cam that suits your machine synchronization cycle.

Configuring and testing your fieldbus node is also quick and easy thanks to the **Fieldbus Configurator**. You can shape the bus exchange memory as you like, selecting the monitors and commands that you need for your applications.

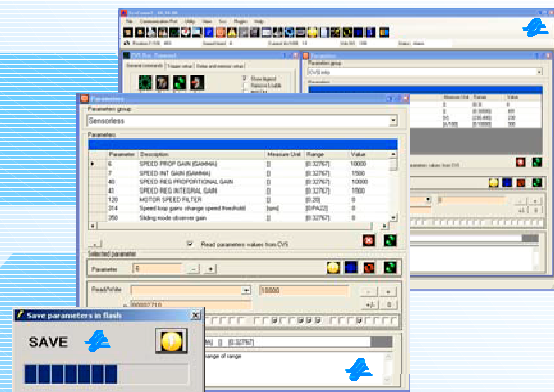

DIGITAL OSCILLOSCOPE

The integrated digital oscilloscope developed by **SCS** can be fully customized in order to let you set the trigger functions and parameters, the acquisition memory size, the acquisition time steps, the traces source and characteristics.

You can choose to acquire and analyse any of the drive variables, grouping them in a single plot and using the scaling functions to let them fit the plotting window in order to easily compare their behaviour.

You can easily tune the drive gains in order to compensate speed ripple or position oscillations by tracing, changing and plotting the drive measures.

ScsComm digital oscilloscope can boost the timing of your startup and commissioning phases allowing you to install and tune the machine easily and quickly.

You can also use the integrated oscilloscope in order to efficiently troubleshoot your application by triggering on a specific alarm or monitor transition.

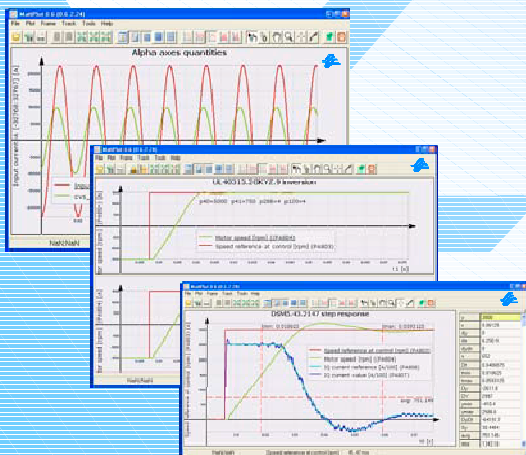

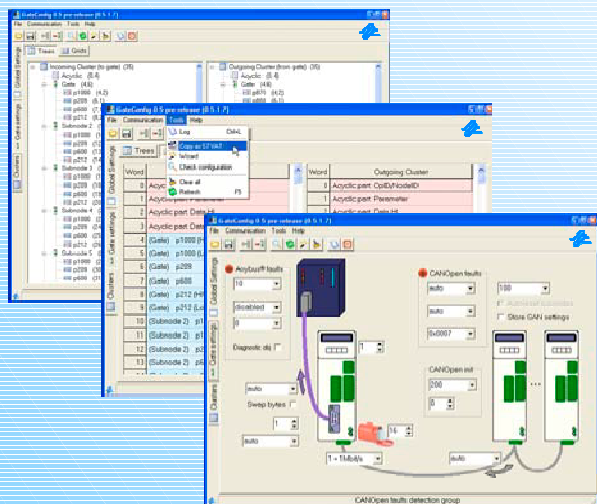

FIELDBUS GATE CONFIGURATOR

In order to let the overall system be simpler and cheaper, SCS developed a special feature in its servo drives: the **fieldbus gate**. You can connect an array of drives to your fieldbus using the first node as the main target.

This drive will take care of managing the communication between the main fieldbus and the CANopen subnet made of the others drives working as a gate.

This means you can use only one fieldbus option distributing the cost on all of the drives in your application, reducing the cost per axes of your system.

SCS developed an **ScsComm** plugin that provides a simple graphical interface to configure the Fieldbus Gate features.

It allows you to quickly set up the data exchange with fieldbus, mapping the incoming and outgoing buffers by means of choosing the read/write parameters and the destination drive (gate itself or subnode connected via CANOpen).

A step by step wizard guides the user to choose proper settings (ex. bus faults timeouts) in order to let the whole system be set up and properly configured for the specific application's needs.

CAM BUILDER

SCS servo drives can be controlled in Electronic Cam mode, this means you can synchronise your application cycle simply using a single tick time (i.e. a master encoder).

You can design your Electronic Cam in a very flexible way, by means of number of nodes, interpolation functions and relative strokes.

You can design and store multiple cams in your drive so that you can select or switch (even on-the-fly) from one to another in the different operational modes of your machine.

The shape and characteristics of each of your Electronic Cams is stored in a proper table that is kept in the drive flash memory.

In order to ease your job in designing and testing the cam shape **SCS** developed a special plugin inside the **ScsComm** PC application.

The **CAM Builder** plugin provides a design environment to build a set of cam profiles and directly download them into the drive.

Main features are speed and acceleration checking, automatic interval joints, cam simulation.

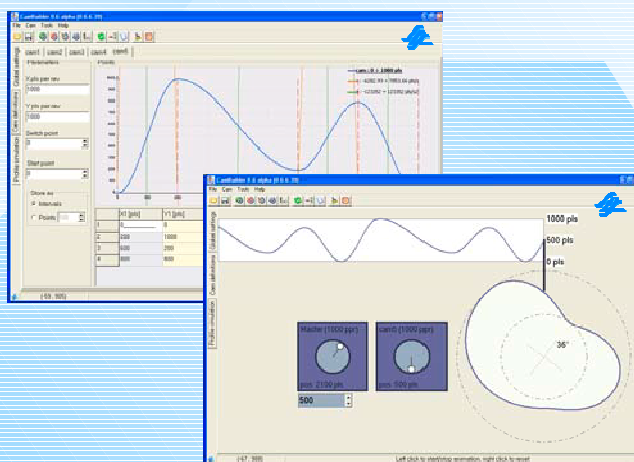

SERVO DRIVES

CVS_{II}

DIGITAL SERVO BRUSHLESS DRIVE

CVS_{II} DIGITAL SERVO DRIVE FOR SINUSOIDAL BRUSHLESS MOTORS

GENERAL DESCRIPTION

- Programmable I/O
 - WideLoop
 - Jog
 - ABS e INC moves
 - Homing auto
 - Electronic Gear
 - Position offset
 - Electronic CAM
- all of the I/O are indexed
the SCS design for total control
manual control mode
integrated positioner
automatic zero pos procedure
multi-ratio on-the-fly change
on-the-fly shifting
graphical design wizard

CHARACTERISTICS

- Pulse train input
 - Encoder Input
 - Encoder Simulator
 - Auxiliary Power Supply
 - Operator keypad
 - Digital I/O
 - Analog I/O
 - Digital I/O expansion
- freq+dir/ quadrature/ CW-CCW
5V line-driver
programmable resolution and zero
optional +24V for control supply
optional and remotable (RS485)
8IN / 4OUT optoisolated
3 references / 3 outputs
14IN / 4OUT optoisolated

CUSTOMIZATION

- Parameter Set
 - Download FW
- up to four parameter sets saved on FLASH
remote update of firmware/applications



CVS_{II} is the servo drive that makes your motion solutions flexible, integrated and reliable.

MAIN FEATURES

Standard

- Diagnostic
 - 2nd Encoder Input
 - Debug/Startup
 - Protection
 - I/O Extension
- last alarm memory
maximum precision on the load side
integrated digital oscilloscope
temporary password generation
put your I/O on CANopen, it's free!

COMMUNICATION

Standard

- RS232/RS485
 - ModBus RTU
 - CANopen (DS301 v.4.0)
- serial communication made easy
standard HMI interface
standard open fieldbus included

Optional

- ProfiBus DP
- ModBus TCP
- DeviceNet
- Industrial Ethernet (PowerLink)
- EtherCAT
- ProfiNet

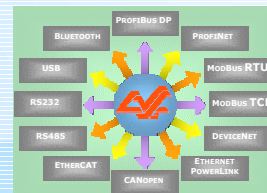

Passive options

- USB
 - BlueTooth
- no more need for serial converters
connection wire-less = limit-less

USER APPLICATION LIBRARY

Put your most time-critical machine functions inside our drive!

Dimensioni e Pesi		CVS23				CVS46				CVS46M	
		03	07	12	18	10	15	20	27	04	06
Weight	[Kg]	4	4	4.2	4.2	7.2	10.9	11.5	11.5	4.1	4.3
A	[mm]	70	70	70*	70*	106	156	156	156	70	70*
B	[mm]	284	284	284	284	360	360	360	360	284	284
C	[mm]	255	255	255	255	300	300	300	300	255	255
Note		* +33mm fan version									

HW Specifications

Switching Frequency	8KHz centered (16KHz)	
Temperature	Nominal: 0° + 40°C (S1 Service)	MAX: 65°C (-1.3% per degree over 40°C)
Analog References	Three inputs: ±10V @ 12bit (one of which differential)	
Analog Output	3 x ±10V not isolated @ 12bit+sign	
Digital I/O	8 input opto-isolated PNP (7mA) @ 24V 4 output opto- isolated PNP (50mA)	
Position Sensor	Resolver, Incremental Encoder ABZ, FA-Coder, Hall Sensors, Absolute SSI Encoder	
Emulated Encoder Output	Programmable pulse/turn Programmable offset for zero marker posizione Output mirror of motor encoder signals	
Comunicazione	RS232 / RS485, ModBus RTU, CANopen	
Options	FieldBus:	ModBus TCP, ProfiBus DP, DeviceNet, ProfiNet, Industrial Ethernet (PowerLink), EtherCAT, ...
	Passive:	USB, BlueTooth I/O Extention Second encoder input
Control Modes	Current, Speed, Position, Electrical Gear, Electrical Cam, WideLoop	
Protection Level	IP20	
European Standards	EN 60146-1-1	
EMC	Emissions	EN 50071-2
	Immunity	EN 50082-2

Product Family

CVS23	CVS23-03	CVS23-07	CVS23-12	CVS23-18
Nominal Current [A]	3	7	12	18
Peak Current [A]	6	14	24	36
Power [KW]	1.5	3	5	7.5
OverCharge	200% for 1s @ duty cycle 1/20			
Power Supply	3 x 220Vac±230Vac (-30% ÷ +10%)		@	50Hz / 60Hz (±10%)
Bus DC Voltage	200V÷355V			
CVS46	CVS46-10	CVS46-15	CVS46-20	CVS46-27
Nominal Current [A]	10	15	20	27
Peak Current [A]	20	30	40	54
Power [KW]	5.0	8.0	11.0	15.0
OverCharge	200% per 1s @ duty cycle 1/20			
Power Supply	3 x 400Vac±460Vac (-20% ÷ +10%)		@	50Hz / 60Hz (±10%)
Bus DC Voltage	400V÷715V			
CVS46M	CVS46M-04	CVS46M-06		
Nominal Current [A]	4	6		
Peak Current [A]	8	12		
Power [KW]	3	4.2		
OverCharge	200% for 1s @ duty cycle 1/20			
Power Supply	3 x 400Vac±460Vac (-20% ÷ +10%)		@	50Hz / 60Hz (±10%)
Bus DC Voltage	400V÷715V			

Ordering code:

CVS XX M YY SC

Family name
Mains voltage (**23** for 230VAC, **46** for 400VAC)
Note : **46M** for compact 400VAC family, see table

Nominal current (23 from 03A to 18A)
(46M from 02A to 06A)
(46 from 10A to 27A)

If present means "CAN option not included"

DC DRIVES PRODUCTS

DC DRIVE PRODUCTS family offers to our customers a wide range of devices that can be use in any DC Motor applications.

SCS designs and produces DC Drives since 1977 and can guarantee to its customers a deep support in building successful solutions and fixing startup and tuning phases.



If you need to **go DC**, **SCS** is the right partner for you.

FULL CONTROLLED

CT38

2/4 QUADRANT FULL CONTROLLED THREE-PHASE DRIVES

CM38

4 QUADRANT FULL CONTROLLED SINGLE PHASE DRIVES

CM220-TR

4 QUADRANT FULL CONTROLLED SINGLE PHASE DRIVES

CT38

2/4 QUADRANT FULL CONTROLLED THREE-PHASE DRIVES FOR D.C. MOTORS – SERIES CT

APPLICATIONS

Unidirectional and bidirectional drives for medium and large power d.c. motors. Constant power and constant torque speed adjustment for spindles, CNC's and machine tools.

Processing lines for plastic and rubber materials, extruders, pinch roll trains, winding machines, mixers, calenders.

Metal wire and sheet working machines, shears, reels, cutters, wire drawing benches, spooling machines, stranding machines, rolling mills, forging machines, flattening machines.

Paper product making and packaging machines, paper mills, packaging industries. Printing machines, including silk-screen printing, offset, rotogravure and continuous machines.

Voltage and/or current regulators for controlling processes, RL loads, galvanic baths, electrophoresis.

MAIN FEATURES

Full standardization design philosophy.

Removable personalization board. Standard control boards without calibration.

Optimum power, size, performance and cost ratio.

Direct connection to mains with wide tolerance ($\pm 20\%$) and random phase sequence.

Very wide current range from 30A to 2700A; built-in voltage changes for mains 220, 380, 440, 480 V $\pm 20\%$.

Galvanic isolation, also in armature feedback, with compensation Rxl.

Adjustable speed relay (0.5 to 120%)

OK relay cumulative of all the protective devices "DRIVER OK".

Thermal overload prealarm relay (I2t). Electronic thermal images.

Provision for setting (1.5x In per 30 s.) and disabling overload.

Commands for controlling references and functions, with LED signalling handled by the PLC or process controls.

Analog current and speed outputs. Differential proportional amplifier, configurable by the user.

Transmission outside of the status of the protective devices, optically isolated parallel and serial.

Standard built-in protective devices (controls of mains and internal power supplies, pulse suppression, solid-state and/or electromechanical fuse alarm, overvoltages, tacho generator failure, field circuit checking, overtemperature, external alarm available) all with LED signalling.

1.1. GENERAL DESCRIPTION

The compact modular construction uses standard PC boards for the entire range, with high level of integration of the components mounted. Thanks to this it is possible to have a series with practically all the most frequently used system auxiliary functions.

Through external commands (contacts or PLC commands signalled by LED's), it is possible to have full control over the switching of the reference signals, Forward/Reverse commands, selection of inputs and use of the ramp. The Forward/Reverse of the reference signals and JOG presettings are interlocked.

All protective devices are memorized individually. Moreover they are signalled by LED's, with external communication in optically isolated parallel form, or transmission in serial form.

The PC board is standard without adjustment.

The personalization and calibration board contains all the adjustments and presettings with an amplifier which can be configured as required.

A special thermal image calculation circuit allows both overloading (3 to 30 s.) as well as boosted continuous service, which is useful for current regulators in "pull mode" with unit torque (torque controls).

In order to afford full protection to the drive, all fuses necessary for the power section are installed internally (SCR bridge, ventilation, field circuit, power supply).

The drive is built to IEC standards 146, 146A, 146.2, VDE110b, IEC 494-CT 22-2 and the ANIE recommendations. Components with UL, CSA and VDE mark are used. There is provision for mounting fuses to BS88 part 4-1976 and IEC 269 part 4 (standard) and type XL-F and SF to UL standards (upon request). The drive is rated for mains power supplies up to 500V $\pm 10\%$.

1.2. INTERNAL PROTECTIVE DEVICES

- Main fuses (3) for the power bridge (version CT..T/VT) with fuses on the dc side (external) only when used as an inverter rectifier (unidirectional, 2 quadrants)
- Branch fuses (6) for version CT..TR/VTR (reversible, 4 quadrants)
- Fuses for the field bridge (2)
- Fuses for the fan (2) when provided (only for CT...V)
- Fuses for the control circuit (3)
- Checking of firing of each single SCR, solid-state fuse alarm, with provision for optional internal and/or external additional electromechanical checking (AF), provision for disabling.
- Pulse suppression for uncontrollable d.c. overcurrent (200%) (SI).
- Check for mains tolerance missing phases, mains failures presence of - 15V (CR).
- Check for overvoltages and efficiency of peak voltage killer filter (only for high power ratings) (FS)



- Checking for tacho generator failure (ADT).
- Checking of field circuit by means of adjustable transducer (MCE)
- Thermal overload protection through thermal element on the radiator and calculation of thermal image limiting (TH)
- Signalling of prealarms through relays at 80% of time limit (I2t).

2.0. CALIBRATION AND PERSONALIZATION BOARD (T-RT2, T-RT2R)

Implemented with passive and/or calibration components (apart from the auxiliary amplifier). The board is with plug-in connector and can be replaced by a more sophisticated uP board.

settings through trimmers Nmax, Nmin, JOG, + a, - a, + Imax, - Imax, AZZ, Rxl, D-VEL, P-VEL, I-VEL, G2, P-COR, I-COR, In, TI2t, IE, VO.

Available presettings AR/DT, JCR/JSR,CR/SR, - E1/E1

8 - position dip switches for programming and/or disabling certain protective devices or commands.

3.0. ADJUSTMENT BOARD RT2-RTR2

5.0. SPECIFICATION

Standard supply voltage for control circuit, 3 x 220, 380, 440, 480 ± 20% with built-in voltage change (200 ± 10%, 235±10%, 415±10%, 420±15%, 460±15%, 500V±10%).

Set of 3 fuses with random sequence.

Standard power circuit supply voltage (3x 415V) ± 10% max.

Max voltage 3x500V± 10% (upon request, for CT44..CT48..)

Frequency 50Hz ± 4% or else 60 Hz ± 4% (set by SW6)

Forced ventilation: 220V single phase 50/60 Hz only for types CT..VT/VTR

Operating temperature range: 0°C to 45°C (effective) (inside the control panel) for unventilated models, at nominal current (35°C for ventilated models)

Max permissible operating temperature : 65°C with down grading of 1.25% for each degree from 45° (35°) up to 65°C.

Storage temperature range : - 25°C to + 85°C.

Relative humidity 50% without condensate

Altitude 1000 m above sea level, with down grading of 1.2% for every 100m above this altitude.

Max form factor 1.05

Field circuit supply voltage 2x415V ± 10%max; complete with fuses, transducer, protective devices. Single phase full bridge.

Max current 12A (20A upon request)

Adjustment characteristic : double closed loop in series, for current (TA) and speed (DT) or voltage (VA)

Adaptive characteristic adjustable with trimmers (P-COR, I_COR)

for current loop, D-VEL, P-VEL, I-VEL for speed loop).

Typical range of adjustment 1/200 with tacho gen. Feedback

1/20 with armature feedback and RX1 compensation.

Static speed error with tacho feedback with transient finished and excluding the speed transducers errors :

- Auxiliary protection available (external trip); provision for use as signalling or memorized stop (ET)

N.B.: all protective devices are sent at output through connector X3, individually through OPTO and in serial form for connection to receiver RX8.

Fully standard, without any calibration

Provision for back panel mounting of an optional board in E1 format (100x160).

4.1. POWER SECTION

Full controlled three phase SCR bridge (6SRC's) for the CT..T/VT version and with 6+6 SCR's in anti-parallel (CT..TR/VTR) complete with fuses, filters, single RC filters and protection against overvoltage and dv/dt.

SCR firing board (ZT6/ZT12) adjacent to the modules.

Board with filters, auxiliary fuses and isolating transducers for armature and field.

± 0.01% of max speed for load variation from 5% to 100%;

± 0.05% of actual speed for mains fluctuations of 20%;

± 0.01% of actual speed for each degree in ambient

temperature change from 0° to 65°C.

Internal reference voltage ± 10V ± 2% typical, 20mA max

Reference potentiometer : standard value 5K (from 1K to 10K)

Input impedance of reference signal : 44K ± 2% (0.23 mA typical)

Positive logic commands (standard + 24V ± 20% 5mA), immunity level 13V at 1.5mA. Contacts or PNP outputs from PLC

Thermal image I2t, adjustable (3s±30s) with duty cycle 1/20; can be disabled. Standard overloading 1.5x In for 30 sec.

Optically isolated outputs for the protective devices, loading capacity 30mA/35V max

Serial output for connection with alarms receiver Rx8

Relay output 5A/220V load R, 3A/220V load RL

Available outputs + 15V/20mA, -15V/20mA, + 24V/100mA

Analog outputs for speed and current signals, with actual sign; ± 10Vmax ± 1mA max

Auxiliary circuits mounted as standard:

Speed ramp: 2 to 60 sec. (0.2 to 6 sec. In RAP), independent +a, -a, reset (RV)

Speed relay: adjustable from 0.5% to 120% (NR)

Check for field failure: adjustable from 0.25% to 100% (MCE)

Thermal image I2t; total time adjustable from 3 to 30 s. Current from 50 to 100%

Prealarm relay

Mains check (CR) - Pulse suppression (SI) - Tacho generator alarm (ADT) - Check for switching on and solid-state fuse alarm (CA+AF) - Armature transducer (TV) - Proportional amplifier (1/2 AP2)

6.0. APPLICATION TABLE

DRIVE	In	Ip	Ith	ARMATURE VOLTAGE (3)		MOTOR POWER KW (4)		DIMENSIONS			MAIN IND.	WEIGHT kg CT..TR
				CT..T	CT..TR	CT..T	CT..TR	W	H	D		
CT38 30...	30	45	37	440	400	11 (14)	(12)	280	385	230	LT40	10
CT38 46...	46	70	55	440	400	(20)	(19)	280	385	230	LT41	10
CT38 55...	55	85	70	440	400	(26)	(24)	280	385	230	LT42	10
CT38 75...	75	110	90	440	400	(33)	(31)	280	385	230	LT43	11,5
CT38 83...(x)	83	125	103	440	400	(38)	(36)	280	385	230	LT44	11,5
CT38 105V...	105	155	135	440	400	(50)	(47)	280	505	230	LT45	13
CT38 135V...	135	200	180	440	400	50 (70)	47 (64)	280	505	230	LT46	13
CT38 155V...	155	230	200	440	400	62 (79)	55 (72)	280	505	230	LT47	13
CT38 240V...	240	360	325	440	400	94 (128)	85 (117)	350	605	275	LT48	23,5
CT38 300V...	300	450	405	440	400	118 (160)	108 (145)	350	605	275	LT49	23,5
CT38 330V...	330	495	445	440	400	130 (176)	118 (160)	450	630	290	LT50	33
CT38 390V...	390	585	530	440	400	155 (209)	140 (190)	450	630	290	LT51	33
CT38 425V...	425	635	575	440	400	168 (227)	153 (207)	450	630	290	LT52	33
CT38 510V...	510	765	620	440	400	202 (273)	183 (248)	450	630	290	LT53	33
CT38 600V...	600	900	750	440	400	237 (297)	216 (270)	xx	xx	xx	LT54	
CT38 735V...	735	1100	900	440	400	291 (356)	264 (324)	xx	xx	xx	LT55	
CT38 1000V...	1000	1500	1200	440	400	396 (475)	360 (432)	xx	xx	xx	LT56	
CT38 1270V...	1270	1900	1550	440	400	503 (614)	457 (558)	xx	xx	xx	LT57	
CT38 1400V...	1400	2100	1750	440	400	555 (693)	505 (630)	xx	xx	xx	LT58	

NOTE:

Other sizes upon request, up to 2700A

1 - Max permissible overcurrent for 30 sec. (60 sec. For CT38 - 600 ÷ 1400) - duty cycle 1/20

2 - Thermal current permissible without overload (IEC 146 - class I)

3 - Armature voltage for power supply 3x380 ± 10% IEC 146

4 - Typical motor power ratings which can be used, with efficiency between 0,85 and 0,9, overload of 50%, and mains 380V.

In brackets are stated the typical powers without overload, calculated with Ith.

For mains different from 380V, calculate the proportion.

(x) - Only upon request

xx - To be built in the cabinet; see NT099 - 5.16 for dimensions

Ordering code:

CT 38 155 (V) T (R)

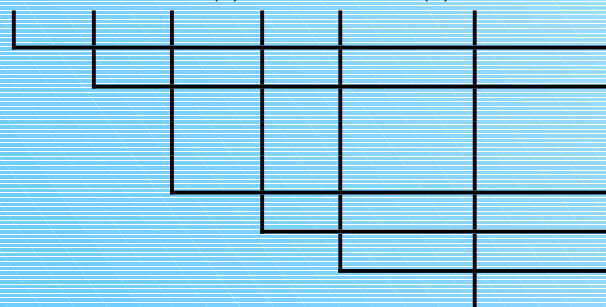

- Digital converter
- Mains voltage: 38 for mains from 200 to 415V
44 for mains from 200 to 460V
48 for mains from 200 to 500V
- Continuous current (from 30A to 1400A)
- Forced ventilation
- Full controlled (2Q)
- Reversible (4Q)

CM38

4 QUADRANT FULL CONTROLLED SINGLE PHASE DRIVES FOR D.C. MOTORS – SERIES CM

APPLICATIONS

- Bidirectional drives for small and medium power D.C. motors
- Processing lines for plastic and rubber materials extruders, pinch roll trains, winding machines.
- Metal wire and sheet working machines, shears, cutters, spooling machines, strading machines.
- Paper product making and packing machines, packaging industries.
- Printing machines, including silk screen, offset.
- Positioning gauges, transfer.

MAIN FEATURES

- Full standardization design philosophy
- Standard control board with SMT technology
- Optimum power, size, performance and cost ratio
- Direct connection to single phase mains with wide tolerance ($\pm 20\%$)
- Selection of the full range current if binary code (4 bit)
- Selection on terminal board for main 220, 380, or 240, 440, 480 $\pm 20\%$
- Galvanic insulation, also in armature feedback, with compensation RxI
- Double slope speed ramps, selectable and with separate zeroing
- Adjustable speed relay (0,5 ÷ 120%)
- OK relay cumulative of all the protective devices 'DRIVER OK'
- Thermal overload prealarm relay (I2t). Electronic thermal images
- Provision for setting (1,5 x In per 30 s.) and disabling overload
- Commands for controlling reference and functions, with LED signalling
- Analog current and speed outputs
- Standard built-in protective devices (controls of mains and internal power supplies, solid state and/or electromechanical fuse alarm, tacho generator failure, field circuit checking disabling by external command, overtemperature) all with LED signalling.



1.0 GENERAL DESCRIPTION

The compact modular construction uses standard PC boards for the entire range. The high level of integration of the components mounted, made possible to have a series with practically all the most frequently used system auxiliary functions.

Through external commands (contacts or PLC commands signalled by LED's), it is possible to have full control over the switching of the reference signals, Forward/Reverse commands and use of the ramp. All protective devices are memorized individually and signalled by LED's.

The PC board is standard. A special thermal calculation circuit allows both overloading (30s) and boosted continuous service, which is useful for current regulator in 'pull mode' with unit torque (torque controls). The drive is built according to IEC standards 146, IEC 326, VDE 110b, CEI 494-CT22-2 and the ANIE recommendations. The drive is rated for mains power supplies up to 500V $\pm 10\%$.

All auxiliary fuses (field, regulation) are internally mounted. Power fuses are externally mounted.

2.1 INTERNAL PROTECTIVE DEVICES

- Fuses for the field bridge (2)
- Fuses for the control circuit (1)
- Checking of firing of each single SCR, solid-state fuse alarm, with provision for optional external additional electromechanical checking (AF) and provision for disabling.
- Check for mains tolerance, missing phases, mains failure, presence of -15V
- Checking for tacho generator failure
- Checking of field circuit by means of adjustable transducer; provisions for disabling by command

- Thermal overload protection through thermal element on the radiator and calculation of thermal image limit
- Signalling of prealarms through relays at 80% of time limit of thermal images

2.2 STATUS LED ON BARGRAPH

- PW: power alarm (mains, fuses)
- TG: tacho generator alarm
- FC: field circuit checking
- TH: thermal alarm (thermostat/I2t)
- MP: positive modulator (forward bridge)
- MN: negative modulator (reverse bridge)
- I>In: start of thermal image calculation
- I2t: thermal prealarm
- N#0: speed relay
- OKD: driver OK (alarm cumulative)

3.0 CONTROL BOARD RR2 CARD

- Fully standard for all ranges
- Available presetting AR/DT, JCR/JSR, RV1/RV2
- 4-positions dip switches for programming and/or disabling certain protective devices or commands

4.0 POWER SECTION PR2 CARD

- Full controlled single phase 4+4 SCR's in anti-parallel, complete with single RC filters and protection against overvoltage and dv/dt
- Boards with filters, auxiliary fuses and insulating transducers for armature and field

5.0 TECHNICAL DATA

- Standard supply voltage for control circuit 220, 380, or 240/440, or 240/480 ±20% with selection on terminal board (200 ± 10%, 235 ± 10%, 240 ± 20%, 415 ± 10%, 420 ± 15%, 460 ± 15%, 500V ± 10%).
- Standard power circuit supply voltage 415V ± 10% max
- Max voltage 500V ± 10% (upon request, for CM44...CM48)
- Frequency 50Hz ± 4% or 60Hz ± 4% (set by SW 1-4)
- Ref. ambient temperature: 0° to 45°C effective (inside the control panel)
- Max operating temperature: 65°C with derating of 1,25% for each degree from 45° up to 65°C
- Storage temperature range: da -25° a +85°C
- Relative humidity ≤50% without condensation
- Altitude ≤1000 m.a.s.l. with derating of 1,2% for every 100m above this altitude
- Max form factor 1,2
- Field circuit supply voltage 2 x 415V ± 10% max, with single phase bridge, complete with fuses, transducer, protective devices. Max current 2,5A.
- Adjustment characteristic: double closed loop in series, for current (TA) and speed (DT) or voltage
- Typical range of adjustment 1/100 with tacho gen. feedback or 1/10 with armature feedback and RXI compensation.
- Static speed error with tacho feedback and transient finished and excluding the speed transducer errors
- ± 0,01% of max speed for load variation from 5% to 100%
- ± 0,05% of actual speed for mains fluctuations of ± 20%
- ± 0,01% of actual speed for each degree in ambient temperature change from 0° to 65°C
- Internal reference voltage ± 10V ± 2% 10mA max
- Reference potentiometer: standard value 5K (da 1K a 10K)
- Input impedance of reference signal: 200K ± 2% (0,05mA typical)
- Positive logic commands (standard ± 24V ± 20% 5mA) immunity level ≥13V at 1,5mA. Contacts or PNP outputs from PLC
- Thermal image I2t with duty cycle 1/20; can be disabled. Standard overloading 1,5xIn for 30sec.
- Relay outputs 5A/220V load R, 3A/220V load RL
- Available outputs: +15V/10mA, -15V/10mA, +24V/30mA
- Analog outputs for speed and current signals, with actual sign: ±10Vmax, ±4mA max
- Auxiliary circuits mounted as standard
- Speed ramp: 3÷90 sec., ±20% (or 0,3÷9 sec., or 3ms.÷0,1sec.) independent +a, -a, independent stop
- Speed relay: adjustable from 0,5% to 120% with trimmer
- Check of field failure: adjustable from 100mA to 2,5A. Standard value 100mA ± 20%
- Thermal image I2t: total time 30sec. ±20% Prealarm relay

6.0 APPLICATION TABLE

DRIVE	CURRENT			VOLTAGE (3)		MOTOR POWER KW (4)	VOLTAGE (3)		MOTOR POWER KW (4)	DIMENSIONS			WEIGHT Kg
	In	Ith (1)	Ip (2)	mains V~	arm.V=		mains V~	arm.V=		W	H	D	
CM38-11 TR	11	14	16	220	150	1,3	380	260	2,3	190	275	165	2,3
CM38-14 TR	14	18	21	220	150	1,7	380	260	3	190	275	165	2,5
CM38-22 TR	22	26	33	220	150	2,8	380	260	4,8	190	275	165	3,7
CM38-33 TR	33	40	50	220	150	4,2	380	260	7,2	190	275	165	3,8
(x) CM44-11 TR	11	14	16	240	170	1,4	440	300	4,6	190	275	165	2,3
(x) CM44-14 TR	14	18	21	240	170	1,9	440	300	6	190	275	165	2,5
(x) CM44-22 TR	22	26	33	240	170	3,1	440	300	9,6	190	275	165	3,7
(x) CM44-33 TR	33	40	50	240	170	4,7	440	300	14	190	275	165	3,8
(x) CM48-11 TR	11	14	16	240	170	1,4	480	330	5	190	275	165	2,3
(x) CM48-14 TR	14	18	21	240	170	1,9	480	330	6,6	190	275	165	2,5
(x) CM48-22 TR	22	26	33	240	170	3,1	480	330	10,5	190	275	165	3,7
(x) CM48-33 TR	33	40	50	240	170	4,7	480	330	15	190	275	165	3,8

NOTE

- (1) - Thermal current permissible without overload (IEC 146 - class I)
- (2) - Max permissible overcurrent for 30 sec. duty cycle 1/20
- (3) - Mains and motor voltage according to IEC 146 (for other power supplies, please check manual)
- (4) - Typical motor power ratings which can be used, with efficiency between 0,8 and 0,85, overload of 50% and typical power supplies. For different mains, calculate the proportion (see manual)
- (x) - Only upon request

Order code :

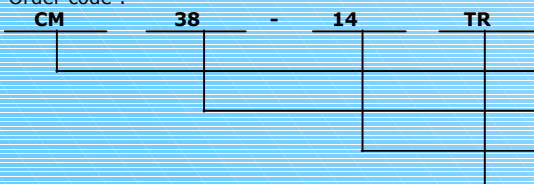

- Single phase converter
- Mains voltage (CM38... CM44... CM48...)
- Continuous current (from 11A to 33A)
- Full controlled Reversible (4Q)

CM220-TR

4-QUADRANT SCR BIDIRECTIONAL FULL CONTROLLED SINGLE-PHASE CONVERTER

APPLICATIONS

- reversible control of low power D.C. motors
- Silkscreen machinery
- Footwear machinery
- Copying machines
- Conveyors

MAIN FEATURES

- Direct installation on single-phase mains supply
- Excellent dimension/cost/performance ratio
- Operating range: from 5A to 10 A
- Independent circuit for the supply of the field circuit
- Internal fuses protection

GENERAL DESCRIPTION

The converter CM 220/5-9-16TR is intended for the reversible supply of low power D.C. motors. The output current is of 5A, 9A, 16A, while the max. output voltage is of 150V. It allows operation in the 4 quadrants, with 8 SCR static switching. An independent circuit for the supply of the field circuit is available. The protection with fuses of the power, field and control circuits is internal. The speed ramp circuit is standard supplied, and can be separately adjusted for the 2 directions of acceleration. A zero speed relay, analog current and speed output are, current limit analog input also available;



GENERAL DESCRIPTION

The converter CM 220/5-9-16TR is intended for the reversible supply of low power D.C. motors. The output current is of 5A, 9A, 16A, while the max. output voltage is of 150V. It allows operation in the 4 quadrants, with 8 SCR static switching. An independent circuit for the supply of the field circuit is available. The protection with fuses of the power, field and control circuits is internal. The speed ramp circuit is standard supplied, and can be separately adjusted for the 2 directions of acceleration. A zero speed relay, analog current and speed output are, current limit analog input also available;

APPLICATION TABLE

	CM220	5TR	9TR	15TR
Max. armature voltage	V	150	150	150
Max. armature current	A	5	9	16
Max. form factor		1.2	1.2	1.2
Converter power	KW	0.750	1.35	2.4
Typical motor power (with n=0.8 and Cp=1.5Cn)	KW	0.4	0.72	1.2
Armature inductance mH (typical for F.F. = 1.1)		175	100	50
It	A	4	7.5	11
Is	A	6	10	17
Field voltage	V	198	198	198
Field current	A	1.5	1.5	1.5
Converter weight	Kg	1.2	1.2	1.8
Dimensions: width	mm	138	138	140
height	mm	222	222	200
depth	mm	70	70	70

TECHNICAL DATA

- Mains supply: 220V±235V±10% or 110V±10% on request. Frequency 50/60Hz internally adjustable (+ 4%)
- Operation temperature: between 0 and 45°C of actual room temperature (cabinet inside) at nominal current. Limit up to 65°C with 1,25% derating for each grade of temperature increasing from 45 to 65°C .
- Form factor: typical 1,2 (F.F.= Iactual./Iaverage)
- Armature voltage: 150V max. with 220V of power, generally you have: $V_{arm}=V_{supply}/1,45$
- Field voltage: 198V max. with 220V supply, and 210V with 235V supply .
- Field current: 1,5A max.
- Adjustment range: 1/200 with tacho-feedback; 1/5 with armature feedback. **Please note:** the RxI compensation is not possible.
- Reference voltage: internal, double regulation at +10V. Voltage variation of ±5% according to the rotation direction. Standard thermal stability ± 0,1% for grade C; ± 0,01% or ± 0,001 upon request.
- Reference potentiometer: standard value 5Kohm. Value between 2÷10Kohm. Minimal power 0,5W
- Auxiliary input: is to be added up to the usual reference; Standard control range ±20% with $R_{aux}=1M\Omega$
- Max. speed control range: Min. input voltage 6V on request.
 - A) with potentiometer N_{max} between 70V and 220V of input feedback EDT1.
 - B) Between 20V and 80V of input feedback EDT2.
- Min. speed control: through the trimmer N_{min} it is possible to control between 0÷20% of the max. speed with reference potentiometer of 5Kohm.
- Speed ramp: separate acceleration and deceleration ramp, which can be adjusted between 0,3 and 10 sec. The exclusion is possible, on request, by obtaining times between 10 msec. and 0,3 sec. Change the capacity should you require longer times.
- Zero speed relay: with LED indicator and an exchange contact with the max. limit of 125V and capacity:
 - 120VA on resistive load 125Vmax
 - 60VA on inductive load 125Vmax

The tacho threshold is 1% of max. speed, while during the armature feedback it is active at about 3V.

Ordering code:

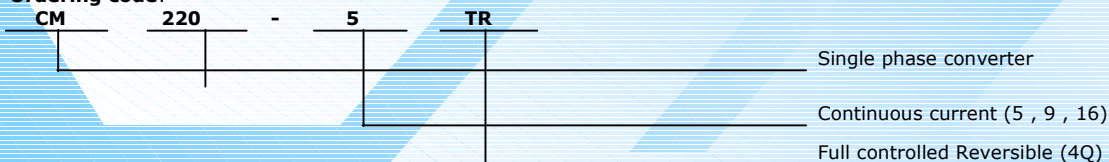

HALF CONTROL D

CM22

HALF-CONTROLLED SINGLE PHASE CONVERTER

CM 220-9S

UNIDIRECTIONAL SINGLE-PHASE HALF-CONTROLLED

CM22

HALF-CONTROLLED SINGLE PHASE CONVERTER

CHARACTERISTICS

CM22 is a family of converters suitable for driving d.c. motors at wound field of low and medium power. They are available in the standard version for connection at single-phase main 230/400V±10% 50-60 Hz, to be selected through jumper; on request also the CM25 is available, for connection at single-phase main 440÷500V ±10% 50-60Hz. CM22 can be supplied in three current sizes from 9 to 27A nominal with overload equal to 150% of the nominal for 30 sec. and with electronic thermal motor protection. CM22 has a mains jumper for the field supply of motor protected by extrarapid fuses and of circuit for field loss. Feedback motors both in armature or in tachodynamo can be driven, which can be connected to the converter without polarity constraints. The circuit of tacholack allows to eliminate overspeed conditions, which are not wished and which could be caused by accidental breaks of the cables coming from the dynamo itself. CM22 is in short a complete product with reference to the group to which it belongs, it can be easily configured through dip switches and jumpers, which allow the selection of main voltage, motor current, value of the armature or tachodynamo voltage. The modular structure allows to optimise the space inside the electrical cabinets and, thanks to the metallic covering, a good grade of noises immunity and a protection grade IP20 in the sizes 9A and 18A are reached.



Type	CM22-09S	CM22-18S	CM22-27S
Dimensions (mm) (Front view)	L=135 H= 294 P=115	L=135 H=294 P=140	L=135 H=294 P=140
Nominal current	9A	18A	27A
Peak current	150% of the nominal current for 30 sec.		
Main voltage and frequency	~ 230/400V±10% 50/60Hz		
Protection grade	Ip20 (Ip00 for CM22-27S)		
Nominal Temperature	0÷ +45°C		

Hardware	Function details
Analog inputs	Speed reference Aux. reference External current limit Speed ramp Tacho-dynamo (126÷220V) Tacho-dynamo (6÷130V)
Logic inputs	Drive enabling input Reference enabling input Jog running Ramp enabling input
Logic outputs	Contact N.O. relay driver OK Contact N.O. speed relay
Signaling leds	Electronic thermal protection Field lack Tacho-dynamo alarm Main alarm Driver OK Speed threshold
Trimming potentiometers	Max. speed Min. speed Jog speed Positive acceleration Current limit Speed threshold Offset Stability RXI compensation
Protections	Control and field fuses Electronic thermal Field loss Tacho-dynamo alarm Main alarm
Reference standard	EN 60146-1-1
Emission EMC Immunity	EN 50081-2 for interferences with ext. filter EN 50082-2

CM 220-9S

UNIDIRECTIONAL SINGLE-PHASE HALF-CONTROLLER CONVERTER OPERATIONS ON 1 QUADRANT

APPLICATIONS

- Unidirectional control of low power d.c. motors
- Silkscreen machinery
- Footwear machinery
- Copying machines
- Conveyors

SPECIAL CHARACTERISTICS

- Direct installation on single-phase mains supply
- Excellent dimension/cost/performance ratio
- Operating range: from 2.5A-5A-9A
- Acc/dec ramps standard appliances on the CM 220/5S-CM 220/9S
- Internal selection of armature or tacho feedback
- Extreme flexibility of use

OPTIONS AVAILABLE ON REQUEST

- Zero speed relay (No) with change over contact on the terminal board (only for CM 220/5S-CM 220/9S)
- Levelling inductance for connection to d.c. side (indispensable for permanent magnet motors)
- Rack version for CM 220/2.5S and CM 220/5S

1.1. GENERAL DESCRIPTION

The CM 220/2.5-5-9S series is designed for the unidirectional power supply of low-powered direct current motors. The output currents are 2.5A-5A-9A continuous, while the maximum output voltages are 170V for mains supplies of 220/Vac-50/60 HZ. On request, other input voltages are available (110-48 Vac-50/60 Hz)

1.2. POWER UNIT

It is made up of a full wave half-controlled single-phase bridge with flywheel diode, complete with filters, fuses and protections. Unidirectional operations on one quadrant. A self-powered field bridge is included. For the CM 220/9S power may be supplied externally to the control circuit and field bridge.

1.3. CONTROL UNIT

Series-connected double closed loop.
External speed (generator) or voltage (armature) loop.
Internal current (shunt) loop.

1.4. LED SIGNALLING

*LED1-ON - shows that converter is enabled (green).
*LED2-No - shows that motor is turning (red) (speed relay excited).
*only for CM 220/5S - CM 220/9S versions.

1.5. ADJUSTMENT TRIMMERS

Nmax=maximum speed
Nmin=minimum speed
Imax=maximum current
Stab.=stability
Rxl=internal drop compensation (only for CM220/5S CM 220/9S)
+ a / - a = acc/dec ramp on CM 220/9S
a = acc/dec ramp on CM 220/5S



2.1. TECHNICAL FEATURES

- a) Supply voltage: single phase 220 Vca $\pm 10\%$ 50/60Hz $\pm 4\%$
- b) Operating temperature: 0-45°. Limit up to 65° with 1.25% derating for each degree of temperature from 45° to 65°.
- c) Form factor: typical 1.2
- d) Armature voltage : max 170Vdc
- e) Field voltage : max 190Vdc
- f) Range of adjustment :
 CM 220/2.5S - 1/20 with tacho feedback
 1/10 with tacho feedback, without Rxl compensation
 CM 220/5S - 1/100 with tacho feedback
 1/10 with armature feedback and Rxl compensation
 CM 220/9S - 1/200 with tacho feedback
 1/20 with armature feedback and Rxl compensation
- g) Precision of adjustment :
 CM 220/2.5S - with armature feedback $\pm 10\%$ of the maximum speed
 with tacho feedback $\pm 2\%$ of the maximum speed, for variations of load
 (5%+100%), supply $\pm 10\%$, and frequency $\pm 4\%$
 CM 220/5S-9S - with armature feedback $\pm 5\%$ of the maximum speed and Rxl compensation.
 with tacho feedback $\pm 0.2\%$ of the maximum speed for variations of load
 from 5 to 100%, supply $\pm 10\%$, and frequencies $\pm 4\%$, excluding tacho
 generator or tacho alternator errors.
- h) Reference potentiometer : value between 2 and 10 Kohm.

OPERATION TABLE

Type	Supply 50-60 Hz	Max Motor* Power	Converter Power	Armature voltage	Armature current	Field voltage	Field current
CM 220/2.5S	220 Vac	200 W	425 W	170 Vdc	2.5 A	190 Vdc	0.50 A
CM 220/5S	220 Vac	550 W	850 W	170 Vdc	5 A	190 Vdc	0.50 A
CM 220/9S	220 Vac	800 W	1.53 KW	170 Vdc	9 A	190 Vdc	0.50 A

* - Available torque = 1.5x rated torque of motor

OVERALL DIMENSIONS

	CM 220/2.5S	CM 220/5S	CM 220/9S
A	100	115	150
B	126	190	255
C	60	90	105
D	119	180	245
E	55	60	50
X	65	70	
Z	85	95	
Weight	0.4 KG	0.8 KG	1.4 KG

DC SERVO DRIVES

CH220 - CH22

UNIDIRECTIONAL MOSFET DRIVE

ST

EUROCARD SERIES TRANSISTOR PWM SERVO AMPLIFIER

SM

EUROCARD E1 SERIES MOSFET PWM SERVO AMPLIFIERS

CH220 - CH22

UNIDIRECTIONAL MOSFET DRIVE

CHARACTERISTICS

CH220 and CH22 are unidirectional drives, which use mosfets as power elements. These drives are suitable for driving low power motors at wound field or highly efficient permanent magnets motors. They are available in the standard version to be connected to 110/220±20% 50-60Hz single -phase net, protected by extrarapid fuses (on request also the version 24/48V±10% is available). The high commutation frequency (16KHz for CH220 and 10KHz for CH22) allows to obtain a very good form factor, even without using armature inductance. CH220 is available in three current sizes from 3 to 10A nominal with peak current of 150% of the nominal for 30 sec. and is able to drive motors with powers till 2Kw. CH22 is available in only one size with nominal current of 3.3A and peak current of 5A and is able to drive motors with max. power of 0.55Kw. Both families of products are manufactured in accordance with the product standard for powerelectronics EN 60146-1-1. Concerning the electromagnetical compatibility (EMC), CH220 and CH22 are immune from electromagnetical interferences in industrial environment in accordance with EN 50082-2 and respect the emission specifications in industrial environment in accordance with EN 50081-2 if they are coupled to an external filter and correctly installed in a system, as stated in the instruction manual.



Type	CH22-03
Nominal current	3.3A
Max. current	5A adjustable with jumper
Main voltage and frequency	1~220/110V±20% 50/60 Hz
Nominal temperature	0 ÷ +40°C
Protection grade	IP00 (IP20 on request)
Analog inputs	No. 1 reference
Logic inputs	Enabling input
Logic outputs	Contact N.O. Zero speed
Signaling leds	Power ON
Trimming potentiometers	Stability Max. speed Ramp Min. speed
Dimensions [mm] (front view)	L=190 H=115 D=80

Type	CH220-03G	CH220-06G	CH220-10G
Dimensions [mm] (front view)	L=190 H=100 D=67	L=180 H=100 D=80	L=180 H=100 D=80
Nominal current	3A	6A	10A
Peak current	150% of the nominal current with automatic return (electronicthermic relay)		
Main voltage and frequency	~ 220/110V±10% 50/60Hz		
Protection grade	IP00 (IP20 on request) Rack version on request		
Nominal Temperature	0÷ +45°C		
Options	Zero speed relay (CH-NO) Galvanic insulation (CH-GI)		
Analog inputs	No. 1 main reference		
Logic inputs	Enabling input		
Logic outputs	Driver OK Contact N.O. zero speed		
Signaling leds	Power ON Power alarm Electronic thermic intervention Zero speed		
Trimming potentiometers	Stability Max. speed Min. speed No. 2 speed ramps Current limit RXI compensation Zero speed		
Protections	Low value of armature inductance Load short circuit Equalization condensers degradation Tachymetric dynamo inversion Heatsink overtemp. (only 6 and 10A)		

ST

EUROCARD E1 ST SERIES TRANSISTOR PWM SERVO AMPLIFIER FOR D.C. MOTORS

GENERAL

- Single axis version incorporating power supply and clamp circuit
- Rack or panel mounting
- Optimum quality, size and cost ratio
- Compact design 3U/14TE

FEATURES

- 2KHz four quadrant PWM operation
- Motor voltage range from 10 to 80V
- Continuous current up to 4A
- Peak current up to 8A
- Internal armature feedback
- Thermal image and current limit
- Differential reference input
- 3 LED status indicators



Removable calibration board with surface mounting technology (smt)

MAIN FEATURES

The SCS Servocontrol of the ST series has been designed to drive small power, high performance permanent magnet motors. It features four quadrant reversible operation, while its internal clamp circuit ensures dissipation of inertial deceleration energy. The built-in fuse cuts off the power supply from the power bridge in the event of faults or short circuits.

The series ST Servocontrol is part of a system consisting of:

- Servo amplifier: in open-frame or connector version
- Minimum inductance: to guarantee a form factor of 1.005
- Single phase transformer with central socket: required for supplying the power and control circuits.
- Connector board RK16: for version with DIN 41612 connector; output with terminal board and PC board holder guides.

The following table gives details of the entire system supplied by SCS plus relative order codes:

Type	Transformer drop ≤ 5%			Minimum inductance				Converter		
								Nominal voltage	Armature current	
	Type	Pow.W	Va.c.	Type	mH	IT	IS		V	IN
ST 24 - 4	TR01	200	25	L01	5	5	9	24	4	8
ST 48 - 4	TR02	350	42	L02	9	5	9	48	4	8
ST 65 - 4	TR03	475	57	L03	11	5	9	65	4	8
ST 80 - 4	TR04	580	66	L04	14	5	9	80	4	8

N.B.: To obtain the max r.p.m. at nominal torque (I nom.), decrease the max motor voltages by the percentage no-load/load drop of the transformer, which is 5-6% on the average.

ADJUSTMENT TRIMMERS:

- Maximum speed: through Nmax [P1]
- Maximum current: through IP [P2]
- Nominal current: through IN [P3]
- Offset: through AZZ [P4]
- Stability: through STAB [P5]

LED STATUS INDICATORS

- LD1 (red) OK External enable
- LD2 (red) I2t Thermal image intervention
- LD3 (red) ± 15V Voltages present

GENERAL RULES

(Italian D.P.R. n.224 dated 24/05/88 - EEC Directive n.374/85)

This equipment should only be used, installed and adjusted by specialized and qualified personnel who are familiar with the construction and operation of both system and equipment, on the basis of the technical specifications of the product.

All the necessary precautions should be taken in the system where the product is used in order to safeguard the operator in the event of equipment failure.

SPECIFICATION

Supply voltage: through transformer 380/220v ± 10% (see table on page 2).

Output current: continuous 4a

peak 8a for 2 sec. with pause of 10 sec.

Temperature range: from 0 to 45°C inside control cabinet

Range of adjustment: from 1 to 2000 with tacho feedback

from 1 to 20 with armature feedback

Form factor: 1.005

Static error (at transient depleted): with armature feedback ± 1% of the maximum speed

with tacho feedback ± 0.1% of the maximum speed.

Input voltage: ± 10v

Input impedance: > 10 kohm

Internal reference voltage: ± 10v; ± 2%; 10 ma max

Enable signal: + 18v to + 30v, input current 5 ma a 24v

Available voltage: + 24v; ± 20%; 5ma max

Speed setting potentiometer: range from 2 to 10 kohm. typical setting 5 kohm.

Weight: 500 grams

Dimensions: 100 x 160 x 71 (3u; 14te)

Armature feedback: internal from 10v to 80v.

Tacho feedback: 1 input for feedback from 12 to 60v (from 2.5v to 12v upon request) [edt2]

1 input for feedback from 60 to 240v [edt1]

ORDER DATA

MAIN DATA				FUNCTIONAL DATA	
1	Rated motor power (please state KW or HP)			7	Rack or open – frame version
2	Rated motor voltage			8	Speed or torque control
3	Motor peak current			9	Armature or tacho feedback
4	Continuous motor current			10	Feedback voltage (value of DT/1000')
5	Max motor speed			11	Number of operating cycles
6	Ambient temperature ST> 45° YES <input type="checkbox"/> NO <input type="checkbox"/>			12	Data regarding special, non-standard orders

Single-phase power supply transformer with back-panel (BPM)

When using a BPM back-panel (available in the 2 versions BPM48 or BPM80) it is possible to use a transformer with single-phase secondary and usual power supply voltage. Thanks to this particular rack no kind of current protection on the secondary of the transformer is necessary, as it is already included in the board.

BPM use table

POWER	VCA	CONVERTER
200W	24V	ST24 - 4 / 8 TR
350W	42V	ST48 - 4 / 8 TR
580W	66V	ST80 - 4 / 8 TR

Typical connection scheme

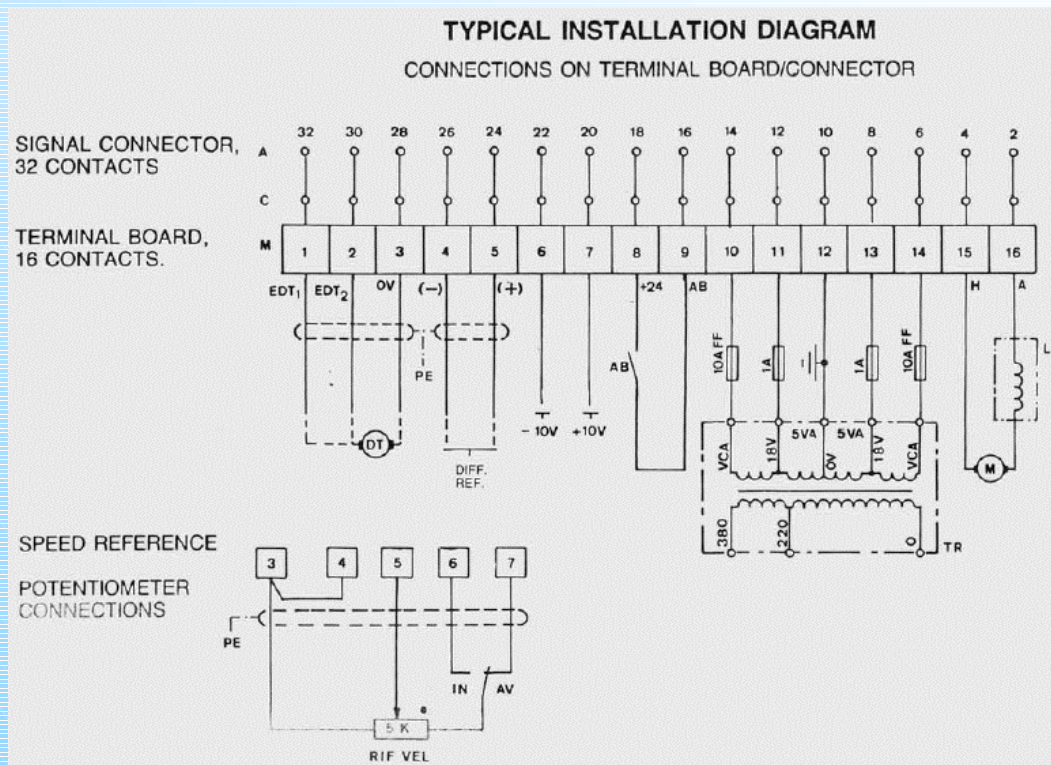

Connection diagram of terminal board M1 with BPM

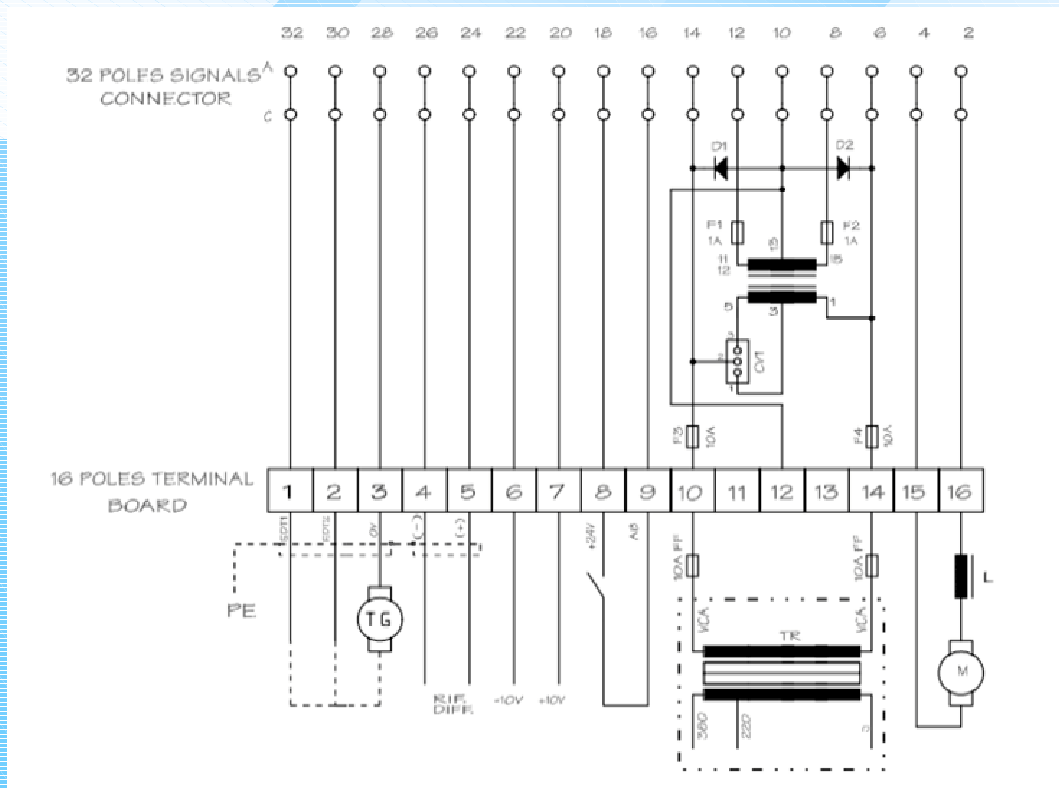

SM

EUROCARD E1 SERIES MOSFET PWM SERVO AMPLIFIERS FOR D.C. MOTORS

APPLICATIONS

- CNC machines, multi-axis systems
- Positioning drives, robots
- Transfer lines, winding machines, cutters

FEATURES

- 16 KHz four quadrant PWM operation
- for motors up to 1 KW
- single axis version incorporating power supply and clamp circuit
- rack or panel mounting
- LED diagnostics
- Removable calibration board with surface mounting technology (SMT)
- Wide motor voltage range 20V – 140 V
- Continuous current up to 10A
- Peak current up to 20A
- Compact design 3U/14TE

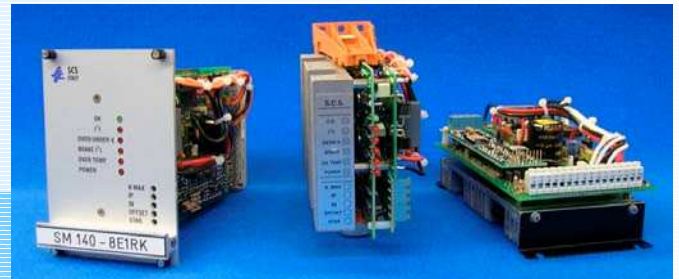

LED DIAGNOSTICS AND PROTECTION CIRCUITS

LD1 (green) Driver O.K., no protective device tripped, normally on.

The remaining red LED's are normally off. When lit up, it means their corresponding function is active. Current limiting is actuated without cutting off the driver (reversible protection).

LD2 STOP I²t current limit intervention (I_{peak} = I_{cont})

The lighting up of the following LED's signals which circuit has cut off the driver irreversibly, with the driver OK LED off; this is also signalled at output.

LD3 OVERUNDER V Overvoltage – undervoltage

LD4 BRAKE L²T Inertial load energy dissipation limit or clamp circuit fault.

LD5 OVER TEMP. Heatsink overtemperature (> 90°C)

LD6 POWER Shorts between outputs, or output and supply

M SYSTEM

The SM drives in their standard version are complete with power supply and clamp circuit. They require three phase voltage only supplied from a suitable transformer.

They can also be supplied in single phase versions with additional external capacitor (approx.1000 to 1500) µF for each ampere), as well as the versions running on continuous external supply or battery, which are without the braking device.

The SM series Servo Amplifiers are part of a system made up of the drive, transformer, inductance (if required) and the optionals for the various assemblings.

Plastic Board holder with terminal board connection.

Inductance.

The value given in table 1 is the one calculated for maximum voltage.

The current refers to thermal and saturation amperages.

Back panel for 19" european rack.

To use only with servo amplifier equipped with connector output.

Panel mounting

Back-of-board mounting

Aluminium front panel

14TE width

18TE width

Transformer

Optionals order code

RK - 16

e.g. LM82

BKP16

BKR16

SM - F

SM - F18

MAIN FEATURES

The SCS MOSFET Servo Amplifiers of the new SM series have been designed to drive high performance d.c. motors. They employ the most up-to-date electronic circuitry for the servo amplifier and the diagnostics, there by optimizing the products as regards dimensions, features and price.

- ◆ Mosfet clamp circuit for dissipation of inertial load energy featuring resistor thermal image protection and output signalling.
- ◆ 2 KHz current loop passaband.
- ◆ Operation in speed mode or as current amplifier.
- ◆ Differential inverting/non inverting inputs ($\pm 10V$), input impedance 20 Kohm.
- ◆ 2 tacho generator inputs for voltage ranging from 2.5V to 240V.
- ◆ Motor on/off and protective device reset inputs (24V 5 mA) $\pm 10 V/20 mA (\pm 5\%)$ outputs, thermal stability $\pm 0.02\%^\circ C$.
- ◆ Overload time of 2 sec.
- ◆ Output with open collector (35V/30mA), drive O.K.
- ◆ Circuit for operation with armature feedback.
- ◆ Removable calibration board (Nmax, Ip, In, Offset, Stability) with SMT technology.
- ◆ LED diagnostics.
- ◆ Weight = 0.7 kg.
- ◆ Dimensions = 100 x 160 x 71 mm. (3U; 14TE); 100 x 160 x 90 (3U; 18TE).
- ◆ Natural air cooling
- ◆ Operating temperature range 0° - 45°C inside control cabinet.
- ◆ Max. temperature 65°C inside cabinet with current derating of 1,5%°C.

ELECTRICAL CHARACTERISTICS

Type	Max motor voltage (V) [2]	Supply voltage (V)	Cont./peak current (A)	3-phase transformer no load secondary voltage (V)	Min.load inductance			Width	Power losses [W]
					mH	AT/AS	Code		
SM 48-10... [1]	16-45	31-60	10/20	23-45	0.7	12/27	LM82	14TE	60
SM 65-8...	45-60	60-75	8/16	43-56	1	8/18	LM81	14TE	45
SM 80-7...	45-75	60-90	7/14	43-67	1	8/18	LM81	14TE	40
SM 140-5...	45-130	60-145	5/10	43-107	2	5/12	LM84	14TE	32
SM 110-9E1	45-96	60-110	9/18	43-82	1.5	9/20	LM86	18TE	52
SM 140-8E1	45-130	60-145	8/16	43-107	1.5	8/16	LM85	18TE	55
SM 160-10E1 [1]	55-137	70-152	10/20	52-113	0.7	12/27	LM82	18TE	75

NOTE 1: The sizes SM48-10 and SM160-10E1 supply rated current continuously till 35° room. For higher temperatures it is to be applied in current derating of 1,5%°C.

NOTE 2: The max. armature average voltage (Varm) is only indicative, in order to couple the drive to the motor at the best, which allows to have still regulation margin; you can use the following practical formula to calculate the intermediate cases (of transformer):

$$Vca = \frac{Vah + 15}{1.35}$$

NOTE3: The values indicated are the ones, which guarantee the non-operation of protections, in the typical application with three-phase supplier, and that the regulation at max. number of revolutions and at full load (nominal torque equal to I nominal) still happens.



SERVO AMPLIFIER ORDINATION CODE

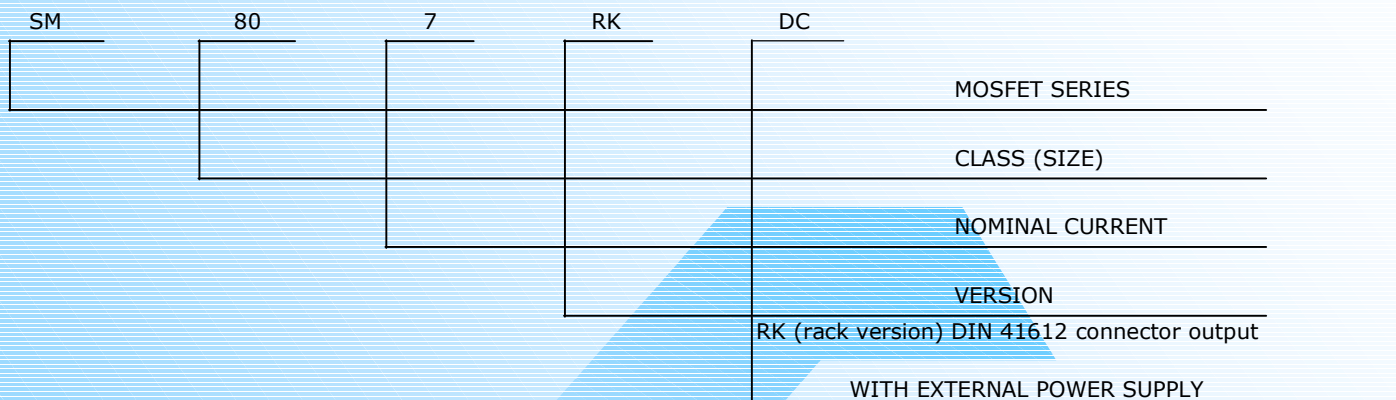

PHASE SHIFTERS

PM22

FULL-WAVE PHASE CONTROL CHARACTERISTICS

PS380

FULL-WAVE PHASE CONTROL CHARACTERISTICS

PM22

FULL-WAVE PHASE CONTROL CHARACTERISTICS

PM22 is a full-wave phase shifter, which uses as power element two antiparallel connected thyristors. Two current sizes are available (28A - 50A), with standard main voltage in class 230V (220-240V±10%) and class 400V (380-415±10%). Upon request we can supply products with voltages till 500V ±10%. PM22 is used for: the current and/or voltage control of resistive elements for the generation of heat, resistive elements with high inrush currents (e. g. quartz lamps), induction rotary heating elements, ohmic-inductive elements. The presence of current and/or voltage reaction signals and of two auxiliary inputs for possible corrections at the control system allows the realisation of different control typologies. Furthermore the values of load current and voltage are at user's disposal.

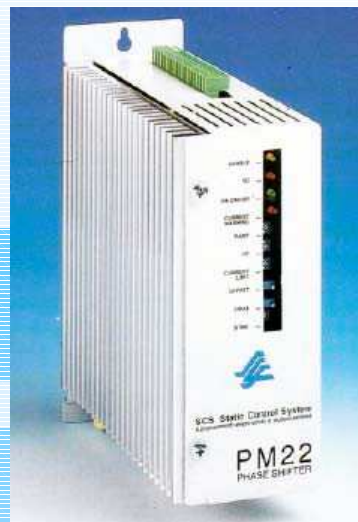

Type	PM22-28	PM22-50
Max. current	28A (30,8A-RMS)	50A (55A-RMS)
Main voltage and frequency	(1~220-240/380-15)±10% 50-60 Hz	
Protection grade	Ip 20	
Ramp	no. 1 adjustable ramp from 0 to 30 sec.	
Current limit	Adjustable between 0 and 100% of the nominal current	
Analog inputs	no. 1 reference input no. 2 auxiliary outputs	
Logic inputs	Opto-insulated enabling input with signaling led	
Analog outputs	Load current Load voltage	
Logic outputs	Contact N.A. driver OK contact N.A. threshold load voltage	

Type	PM22-28	PM22-50
Signaling leds	Enabling input Threshold voltage OK Driver Current limit	
Trimming potentiometer	Ramp Threshold voltage Current limit Offset Min. voltage Stability	
Alarms	Undervoltage and overtemperature sink alarm	
Reference standards	EN 60146-1-1	
EMC Emission Immunity	EN 50081-2 for interferences with external filter EN 50082-2	

DIMENSIONS AND WEIGHTS

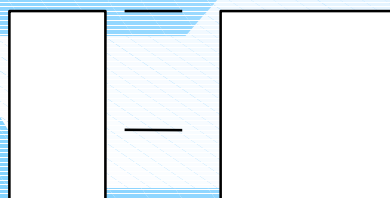

Type	PM22-28	PM22-50
Weight (Kg)	2,2	3,4
A (mm)	80	105
B (mm)	252	252
C (mm)	215	215

PS380

FULL-WAVE THREE PHASE CONTROL CHARACTERISTICS

GENERAL DESCRIPTION

This shifter allows to continuously change the load voltage from 0 to 100% approx.
The adjustment is obtained by means of a potentiometer and minimum and maximum speed are setted with a dedicated trimmer.

APPLICATIONS

- Ohmic load regulation
- Incandescent lamps
- Heaters
- Speed adjustment for helical fans
- Speed adjustment for high rotoric resistance motors (Alquist)

MAIN FEATURES

- Direct installation on mains supply
- Excellent dimension/cost/performance ratio
- Operating range: from 8A to 12 A
- Internal fuses protection

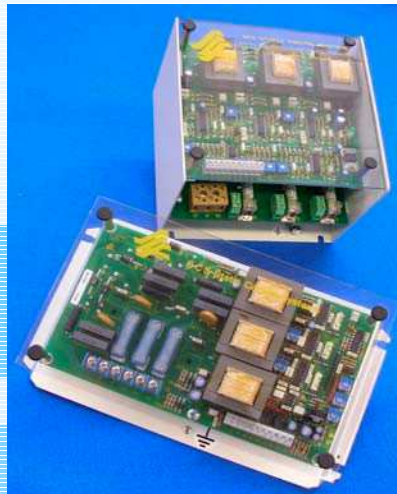

APPLICATION TABLE

TYPE	MAINS VOLTAGE	OUTPUT VOLTAGE	OUTPUT CURRENT	OUTPUT POWER	ABSORBED POWER
PS 380/16S	380V	0 ÷ 380V	16A	10.5KW	10.6KW
PS 220/16S	220V	0 ÷ 220V	16A	6KW	6.1KW
PS 380/20S	380V	0 ÷ 380V	20A	13.1KW	13.3KW
PS 220/20S	220V	0 ÷ 220V	20A	7.6KW	7.7KW

TECHNICAL DATA

- Mains supply: 220V±235V±20% or 110V±20%. Frequency 50/60Hz internally selectable
- Operation temperature: between 0 and 45°C at nominal current. 65°C MAX with 1,25% /°C derating from 45 to 65°C .
- Protection Degree: IP00 according to IEC144
- Internal fuses : 3x10/16 A - 380V (500V) superfast 6,3 x 32
- Weight : 1,2 Kg
- External regulation: manual from 0 to 100% via potentiometer
- Aux outputs: 10V 5mA max , 24V 15mA
- Internal trimmers : minimum and maximum voltage , ramp time

DIMENSIONS

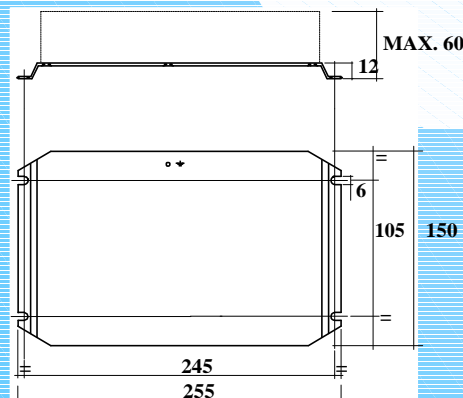

LINE-SIDE PRODUCTS

LINE-SIDE PRODUCTS family offers to our customers a wide range of devices that can directly connect to the power supply line or have to do with DC-BUS connection.

SCS designs and produces DC-BUS power supply units and braking units to be used in big scale applications.

SCS also offers certified EMC filters, line-side and motor-side inductances and braking resistors.

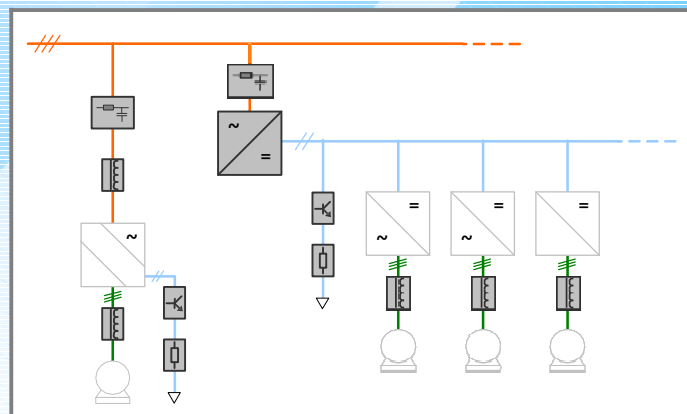

If you need to **fill the line**, **SCS** is the right partner for you.

LINE-SIDE PRODUCTS

DCB

3 PHASE HALF CONTROLLED LINE MODULE

UFS

BRAKING UNIT FOR FREQUENCY INVERTERS/CONVERTERS

RUFC

BRAKING RESISTORS

LT

LINE INDUCTANCES

RF

EMC FILTERS FOR INVERTERS AND CONVERTERS

DCB

3 PHASE HALF CONTROLLED LINE MODULE FOR DC-BUS APPLICATION

GENERAL DESCRIPTION

The DCB40-XXXX line modules are designed for multi-axes drive systems and provide a DC supply to mean and large power inverter.
The DCB40-XXX modules prevent high inrush current charging up the capacitor battery of the inverter gently ramping-up the DC voltage.
The three-phase half controlled SCR based power section covers a wide current and main voltage range.

MAIN FEATURES

Wide current product range
Single regulation board over the whole portfolio increase modularity and spare parts replacement

OTHER FEATURES

Power supply up to 500Vac
ON board regulation and power fuses
External contact ramp enable
Internal or external reference switch
Terminal board relay contacts for alarms
Digital inputs and outputs protection
Safe SCR turn on technology

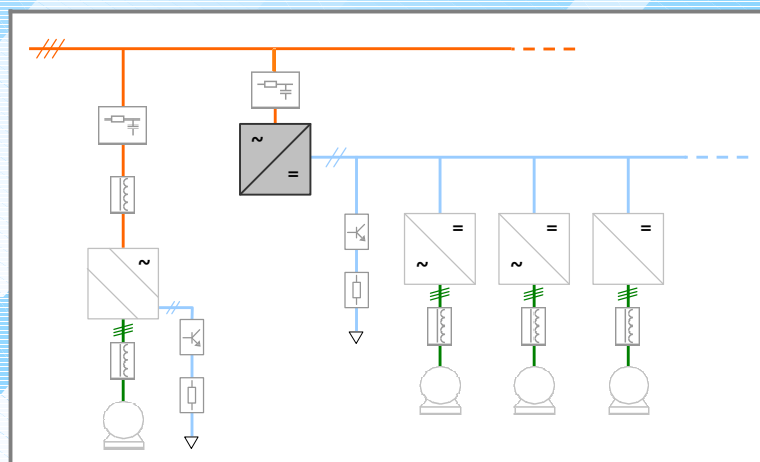
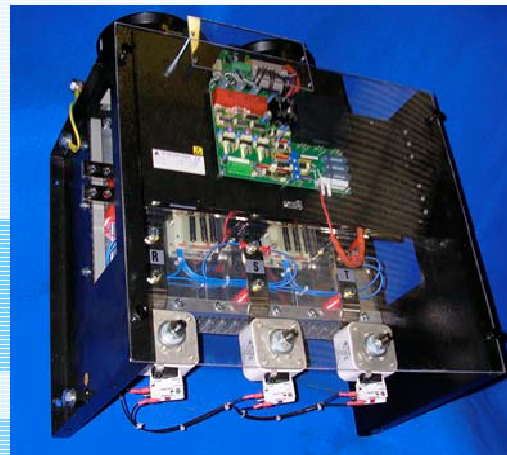

ORDERING DATA

DCB 40-450

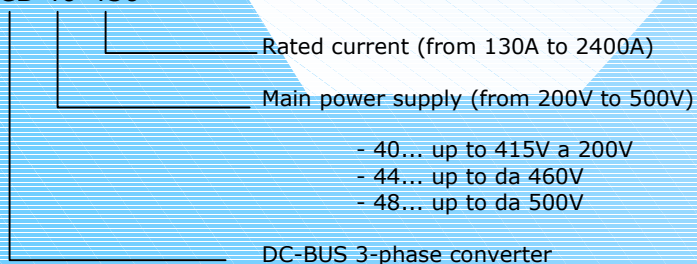

APPLICATION TABLE / PRODUCT SELECTION

Converter	(1)	(2)	(3)	Dimensions		
	In A	Ith A	Ip A	L mm	H mm	P mm
DCBXX-130	130	145	160	190	270	345
DCBXX -165	165	185	200	190	270	345
DCBXX -250	250	280	310	190	270	345
DCBXX -450	450	500	550	500	531	320
DCBXX -575	575	650	720	500	631	320
DCBXX -800	800	900	1000	500	631	320
DCBXX -1100	1100	1200	1350	500	640	335
DCBXX -1300	1300	1450	1600	500	820	335
DCBXX -1550	1550	1800	1900	500	820	335
DCBXX -1800	1800	2000	2200	620	764	402
DCBXX -2400	2400	2700	3000	620	775	432

XX :

- 40 for power supply up to 380V +20% : standard version
- 44 for power supply up to 440V +20% : upon request
- 48 for power supply up to 480V +20% : upon request

- 1) Nominal DC-BUS current for S1 service. (overload permitted) (CEI EN60146)
- 2) Thermal current for for S1 service (overload not permitted) (CEI EN60146)- class I
- 3) Overload current; overload time: 30 sec. max – d.c = 1/20.

TECHNICAL SPECIFICATIONS

- ◆ Power supply and working cycle in accordance with CEI EN60146 (IEC146) - par. 131 EN61800.1
- ◆ Control board standard power supply 3x220V, 380V, 440V, 480V ±20% with internal voltage selection. 200V ±10%, 235V ±10%, 415V ±10%, 420V ±15%, 460V ±15%, 500V ±10%.
- ◆ Control board voltage limits :
220V : da 176V a 264V
380V: da 304V a 456V 440V:
da 352V a 528V 480V: da
384V a 576V
- ◆ Power supply derived from power section (3x400V) +15% max.
- ◆ Maximum voltage 3x500V ±10% (a richiesta, per DCB44...DCB48.....).
- ◆ Frequency: 50Hz ±4% or 60Hz ±4% (selection via CV3).
- ◆ Forced air cooling through built-in fan: single phase 220V .
- ◆ Permissible air temperature: 0° to 40°C at nominal current; up to 65°C with 1,25% derating per grade.
- ◆ Normal Industrial ambient normale, see IEC 146 par.134/135, IEC 68 EN61800.1.
- ◆ Protection degree: IP00 according to IEC 144 - DIN40050.
- ◆ Isolation: in accordance with IEC 326 EN60664- VDE0110 GRC/B.
- ◆ 3 thyristors + 3 diodes bridge (3phase ahlf controlled Graetz B6HK) . Six pulses per cycle at amximum voltage.
- ◆ One quadrant open and closed loop (voltage).
- ◆ Positive logic inputs: (standard +24V +20% 5mA)
- ◆ Relay outputs : 5A/250V
- ◆ Standard auxiliary circuits:
 - Turn-on ramp: 2+20 sec.
 - Voltage loop control (no current loop)

UFS

BRAKING UNITS

GENERAL DESCRIPTION

The UFS braking units are designed to be used with any frequency inverter or converter equipped with BUS-DC. These units can dissipate, through a static chopper, the energy coming from the load during the braking phase. The product family has UL Certification for NAFTA market use.

MAIN FEATURES

- User selectable braking threshold
- Self powered from DC-BUS
- Master-Slave functionality
- Internal electro-mechanical thermal relay with insulated auxiliary contacts for braking resistor protection.
- Standard kits of braking resistors

ORDERING DATA

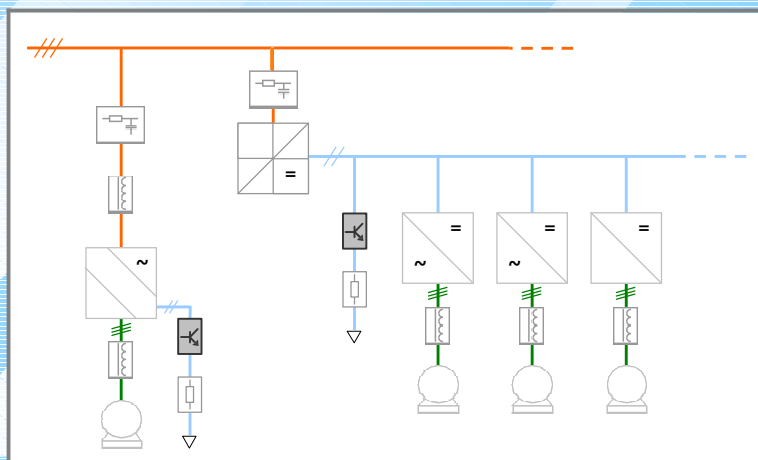
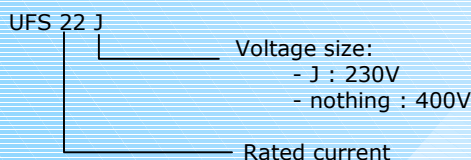

OUTLINE DIMENSIONS

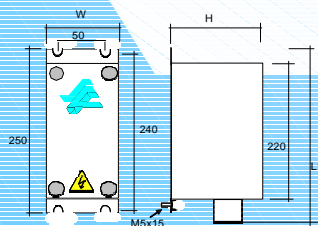



Model	Quote			Weight
	W	L1	H	
UFS15,22,40 UFS15J,22J,40J	100	/	175	2.5 Kg
UFS110	107	270	195	3.9 Kg



APPLICATION TABLE / PRODUCT SELECTION

Unit	Braking voltage Standard (SW1-4 = ON)	Maximum peak current IP (A)	Maximum instantaneous power Pmax (KW)	Standard Ith (A)	%ED Max	RF(Λ) min.
UFS15	745	18	14	4+6	10%	>40
UFS22	745	34	25	7+11	10%	>22
UFS40	745	55	41	12+18	10%	>13,5
UFS110	745	140	105	23+32	5%	>5,3

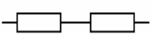
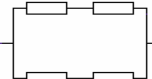
Standard Kit for mains up to 440Vac

Unit	SCS kit		Connection	Overall Resistance	Overall power continuous duty S1	Max power intermittent duty S3 ED 5% (Max 2s cont.)	Dimension s 1 pc L/W/H.
UFS15	RUFC15	1 pz. x 40Λ 1200W		40Λ -0%+10%	1,2 kW	14kW	310/100/75
UFS22	RUFC22	1 pz x 24Λ 2000W		24Λ -0%+10%	2 kW	23kW	365/100/75
UFS40	RUFC40	2 pz. x 6,8Λ 2000W		13,6Λ -0%+10%	4 kW	40kW	365/100/75
UFS110	RUFC110	4 pz. x 6,8Λ 2000W		6,8Λ -0%+10%	8 kW	81kW	365/100/75

Standard Kit for mains up to 330Vac

Unit	SCS Kit		Connection	Total resistance	Total power S1 continuous service	Total power S3 cyclic service ED 5% (Max 2s continuous)*	Dimensions 1 piece L/W/H.
UFS15J	RUFC15J	1 pz. x 24Λ 800W		24Λ -0%+10%	0.8kW	6kW	240x100x75
UFS22J	RUFC22J	1 pz x 12Λ 1200W		12Λ -0%+10%	1.2 kW	12kW	310x100x75
UFS40J	RUFC40J	1 pz. X7.5Λ 2000W		7,5Λ -0%+10%	2kW	19kW	365x100x75

TECHNICAL SPECIFICATIONS

- Tolerance on the intervention voltage: 0.8%
- Hysteresis about 2%
- Ambient temperature 0°C + 40°C
- Maximum braking time = 10s
- Protection degree IP20
- Thermal guard with manual / automatic reset
- DC supply voltage from 450Vdc to 746Vdc (234Vdc+373dc for J version)
- Maximum voltage 800Vdc (400Vdc for J version)
- Main supply voltage from 380Vac to 480Vac +/-10%. (200Vac to 240Vac ±10% for J version)

RUFC

BRAKING RESISTORS

GENERAL DESCRIPTION

The RUFC braking resistors are designed to be connected with UFS braking units so that a braking kit is available for any application of frequency inverter or converter equipped with BUS-DC.

MAIN FEATURES

- excellent performances/dimensions ratio
- low thermal resistance (from 0,6°C/W to 0,24 °C/W)
- easy mounting
- no smoke or fumes
- ROHS compliant

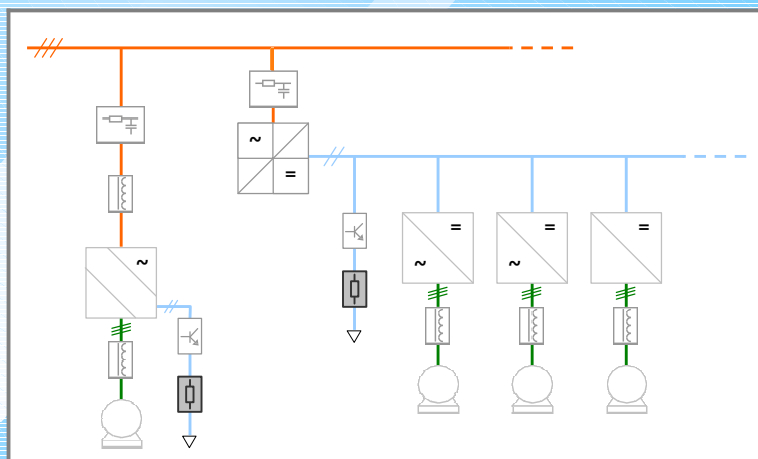

ORDERING DATA REFERENCE TABLE

SCS kit		Overall Resistance	Overall power continuous duty S1	Dimensions [mm] L/W/H
RUFC15	1 pz. x 40 Δ 1200W	40 Δ -0%+10%	1,2 kW	310/100/75
RUFC22	1 pz x 24 Δ 2000W	24 Δ -0%+10%	2 kW	365/100/75
RUFC40	2 pz. x 6,8 Δ 2000W	13,6 Δ -0%+10%	4 kW	365/100/75
RUFC110	4 pz. x 6,8 Δ 2000W	6,8 Δ -0%+10%	8 kW	365/100/75
RUFC15J	1 pz. x 24 Δ 800W	24 Δ -0%+10%	0.8kW	240x100x75
RUFC22J	1 pz x 12 Δ 1200W	12 Δ -0%+10%	1.2 kW	310x100x75
RUFC40J	1 pz. X7.5 Δ 2000W	7,5 Δ -0%+10%	2kW	365x100x75

LT

LINE INDUCTANCES

GENERAL DESCRIPTION

Line inductances can be used coupled with SCS products in both line-side or motor-side configuration.

Single phase and three phase families are available for both DC drives and AC drives coupling.

MAIN FEATURES

- Type test: ENEC 05 - cCSAus - KemaKeur
- Standards : EN 61558-2-13/CSA C.22 N°66/1988/UL 506
- Intended use: Associated
- Short circuit protection: Not-short circuit proof transformers
- Protection against electric shock: Class 1
- Time of operation: Continuous
- Protection level: IP 00/Open core
- Terminals degree protection: IP 20/Finger protection
- Max. ambient temperature: 40°C
- Insulation class: cCSAus: B - 130°C / cULus: F - 155°C
- Frequency: 50/60 Hz
- Tropicalized execution: vacuum pressure varnish



NOTES

Armature or levelling inductance are also available to improve shape factor and avoid overheating of DC Motors and Driver and to reduce brush consumption allowing a lower maintenance and a longer life.

The inductance type are determined with respect to the motor's characteristics and are mandatory in case of SCR Drive and Permanent Magnet Motor coupling.

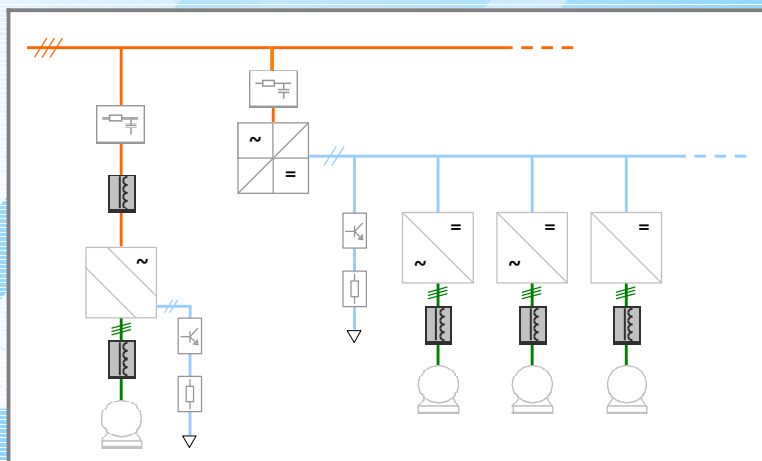

REFERENCE TABLE

CODE	DESCRIPTION	COUPLED WITH
From LT160 To LT137	Three-Phase inductances	DCB40
From LT163 To LT147	Three-Phase inductances	DCB44
From LT166 To LT157	Three-Phase inductances	DCB48
From LT40 To LT58	Three-Phase inductances for DC Drives	CT38, CH220
From LT117, LT117A To LT123, LT123A	Input-Output Three-Phase inductances	CVSII

RF

EMC FILTERS FOR INVERTERS AND CONVERTERS

GENERAL DESCRIPTION

The range of filters offered by SCS has been specially developed for the total accomplishment of the European standards (EN 50081-1 and EN 50081-2).

The measure results for the whole range of filters allow the EMC certification and the possibility of incorporating the CE distinctive to each product.

SPECIAL FEATURES

The EMC Filters can be used both in cabinet configuration (power filters) and in footprint configuration to be coupled directly to the inverters.

FE and FD filter family is certified for Mitsubishi FR-E and FR-D inverters.

MAIN FEATURES

All the filters are manufactured with homologated components:

- Class X and Y Capacitors (VDE, SEMCO, CSA, etc.)
- Protected connection input and output terminals (UL, CSA, VDE, etc.)
- Isolated nuclei with material according to UL94 V0 standard
- Sealed resins according to UL94 V0

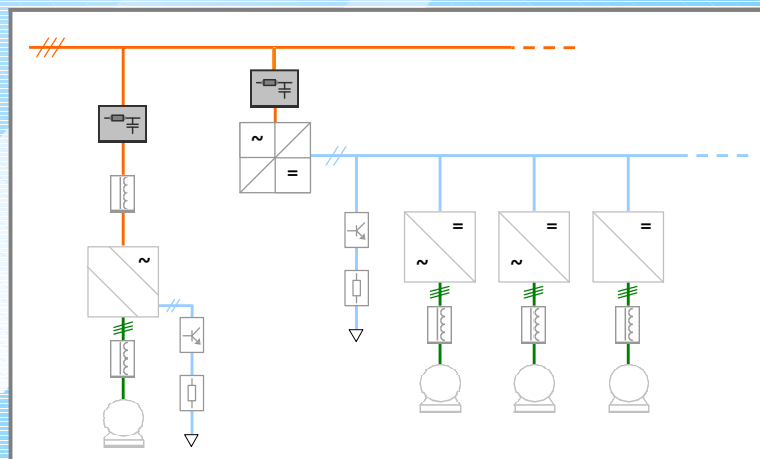

Example: MITSUBISHI INVERTERS COUPLING

	CODICE SCS	Tipo	Descrizione SCS	Abbinamento filtri
FR-D740	FD740-012/022/036-EC	Three Phase Filter 05A.	Filtro EMC per FR-D 740 012-022-036-EC	FR-D740-012-EC FR-D740-022-EC FR-D740-036-EC (0.4kw) (0.75kw) (1.5kw)
	FD740-050/080-EC	Three Phase Filter 15A.	Filtro EMC per FR-D 740 050-080-EC	FR-D740-050-EC FR-D740-080-EC (2.2kw) (3.7kw)
	FD740-120/160-EC	Three Phase Filter 30A.	Filtro EMC per FR-D 740 120-160-EC	FR-D740-120-EC FR-D740-160-EC (5.5kw) (7.5kw)
FR-E740	FE740-016/026/040-EC	Three Phase Filter 05A.	Filtro EMC per FR-E 740 016-026-040-EC	FR-E740-016-EC FR-E740-026-EC FR-E740-040-EC (0.4kw) (0.75kw) (1.5kw)
	FE740-060/095-EC	Three Phase Filter 15A.	Filtro EMC per FR-E 740 060-095-EC	FR-E740-060-EC FR-E740-095-EC (2.2kw) (3.7kw)
	FE740-120/170-EC	Three Phase Filter 30A.	Filtro EMC per FR-E 740 120-170-EC	FR-E740-120-EC FR-E740-170-EC (5.5kw) (7.5kw)
	FE740-230/300-EC	Three Phase Filter 70A.	Filtro EMC per FR-E 740 230-300-EC	FR-E740-230-EC FR-E740-300-EC (11kw) (15kw)