

IMAGO SOFA



## IMAGO SOFA



An icon of the Metamorphosis Collection, the Imago sofa represents the brand's maturity as it begins a new cycle in the design of increasingly timeless pieces, made with noble raw materials of high durability, and crafted using sustainable processes and handmade by our skilled artisans.

Fully articulated, the upholstery features an ultra-modern and original retractable device, hidden within the structure until activated to provide support for the body and head. The organic and curved arms are another highlight of the model, also available in a two-module version.

SIGNED BY **STUDIO INTERACTIVE DESIGN**

**IMAGO**  
SOFA

**GENERAL MEASUREMENTS**

As it is a handcrafted product, variations in the provided measurements may occur. Bell'Arte reserves the right to make modifications to the product without prior notice.

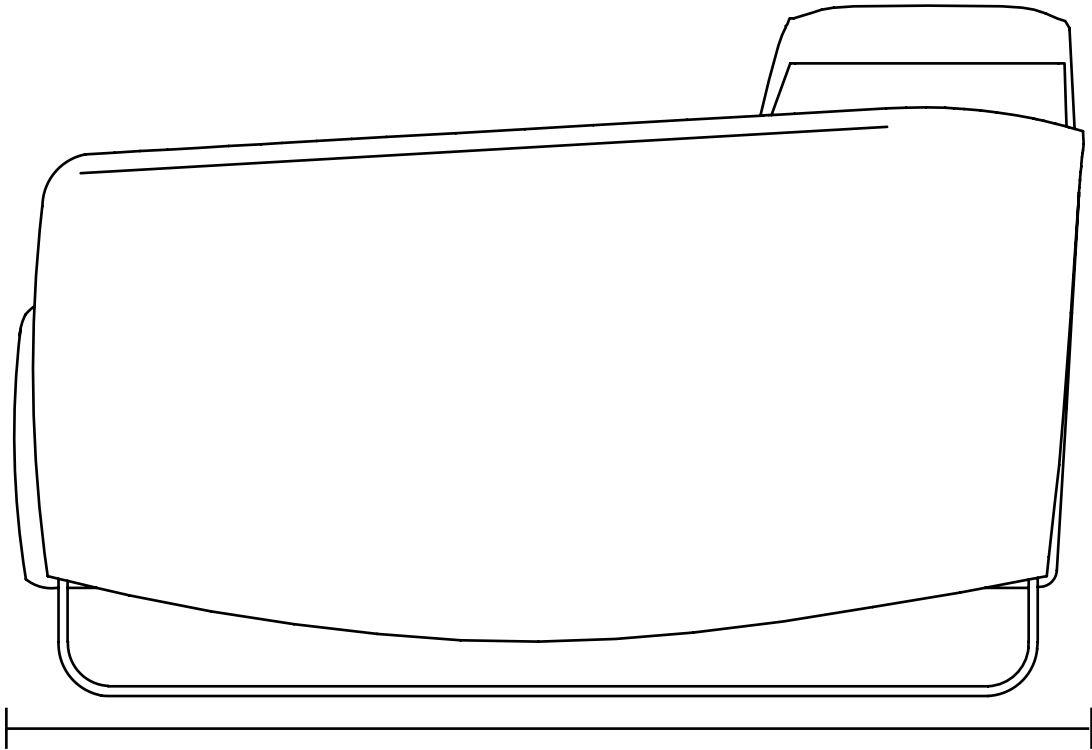

Depth of the closed module:  
42,5"

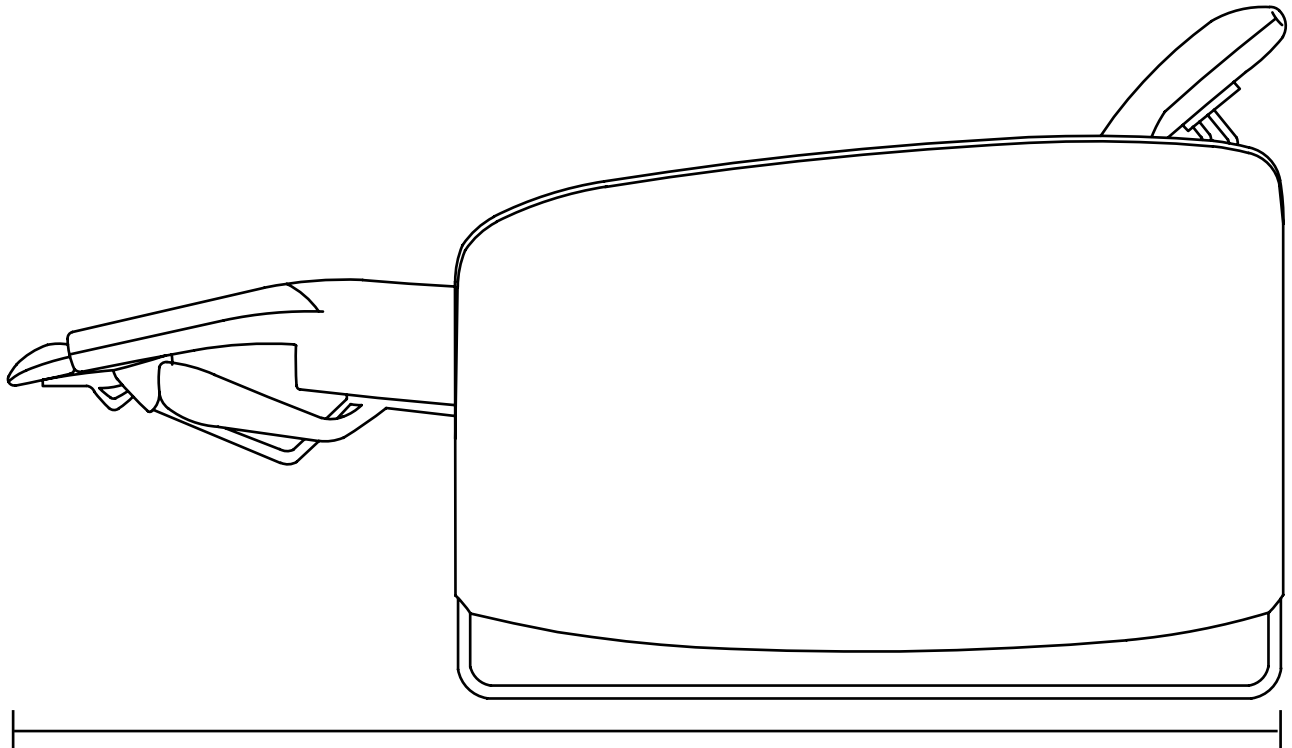

Depth of the open module:  
65,4"

Height of the open module	36,6"
Height of the arm	22,4"
Width of the arm	7,9"
Height of the foot	3,9"

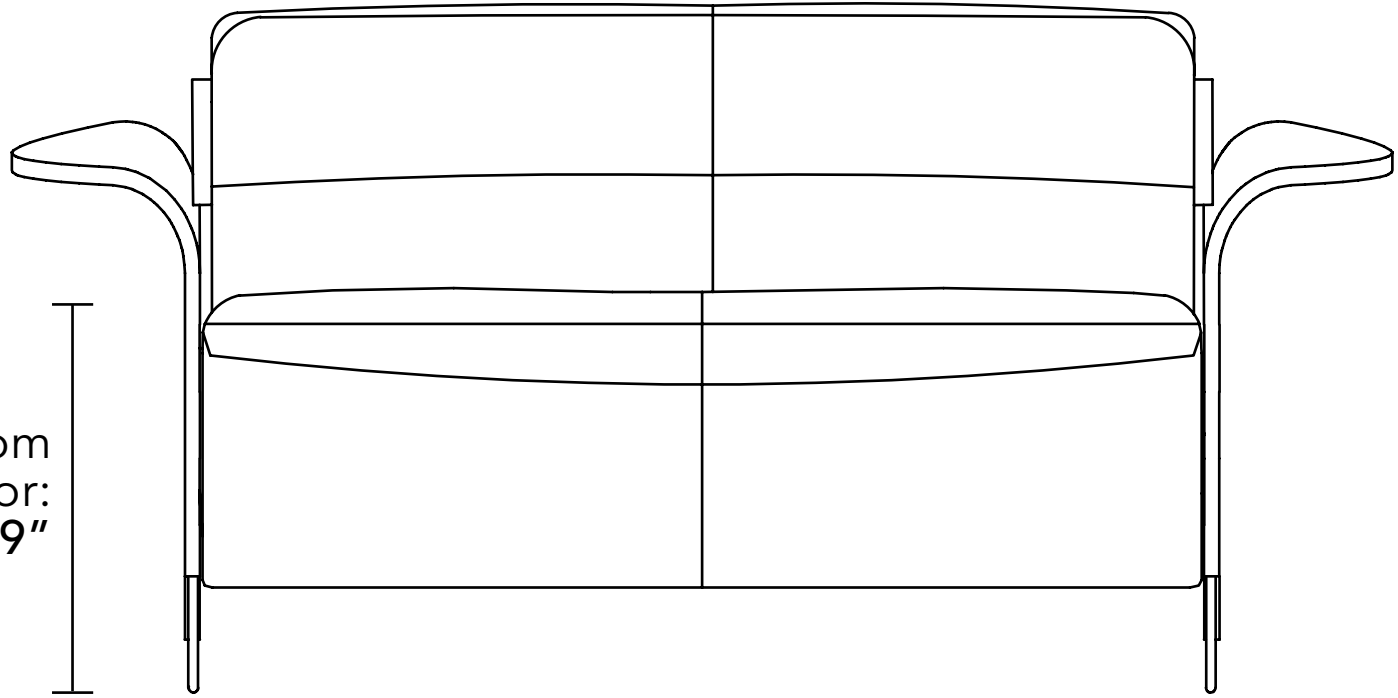

Seat height from  
the floor:  
16,9"

Module height:  
28,3"

IMAGO  
SOFA

AVAILABLE MODULATIONS

As it is a handcrafted product, variations in the provided measurements may occur. Bell'Arte reserves the right to make modifications to the product without prior notice.

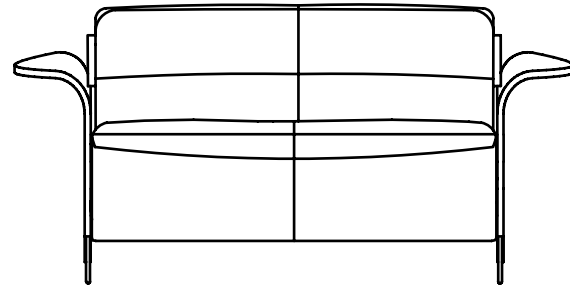

Module - 2 Arms

- 1 Seat of 37,4" + 2 Arms of 7,9" = 53,1"
- 1 Seat of 41,3" + 2 Arms of 7,9" = 57,1"
- 1 Seat of 45,3" + 2 Arms of 7,9" = 61,0"

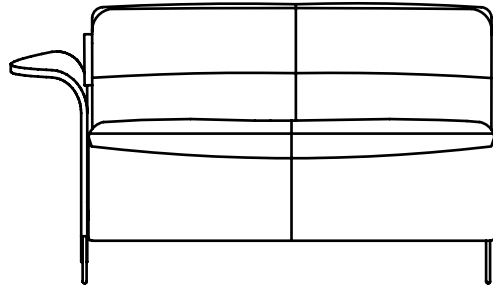

Module - 1 Arm

- 1 Seat of 37,4" + 1 Arm of 0,20 = 45,3"
- 1 Seat of 41,3" + 1 Arm of 0,20 = 49,2"
- 1 Seat of 45,3" + 1 Arm of 0,20 = 53,1"

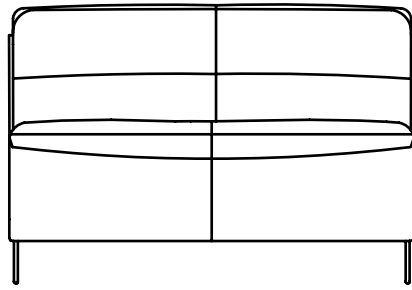

Module - Without Arm

- 1 Seat of 37,4"
- 1 Seat of 41,3"
- 1 Seat of 45,3"

Options:



Motor Kit



Voice Command

# IMAGO

## SOFA

### TECHNICAL INFORMATION

#### Structure

Timbers from certified reforestation (Eucalyptus and Laminated Boards), eco-friendly procedures, and controlled humidity. Automated mechanism with adjustable positioning for the seat, backrest, and foot support.

#### Structure Assembly

The wood joints are held by non-oxidizing staples, and special glue is used to ensure a sturdy and resistant structure, with metal components.

#### Foam

Foams certified according to ISO 9001 standards, produced without CFC.

#### Comfort System

Elastic webbing with springs.

#### Seats

Fixed – foam [density 35 kg/m<sup>3</sup>] covered with polyester fiber.

#### Backrests

Fixed – foam [density 20 kg/m<sup>3</sup>] covered with polyester fiber.

#### Feet

Steel.

#### Removable Parts

Non-removable.



ASSEMBLE WITH THE  
Creator **MOD**



CHECK OUT THIS PRODUCT  
ON THE WEBSITE

