

SERIES SV - PNEUMATIC RACK AND PINION ACTUATOR

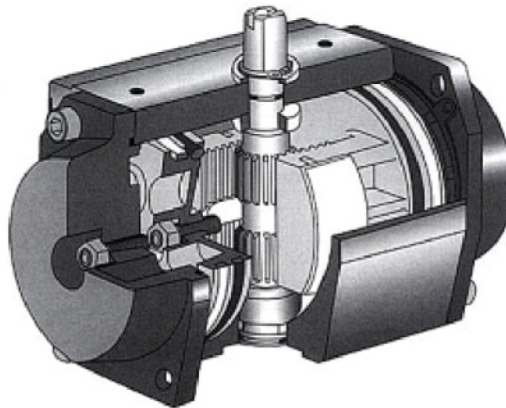

- Rack and Pinion Design
- The standard actuator configuration has hard anodized aluminum body and epoxy coated caps. External protection; resistance to corrosion of 500 hours in salty atmosphere, according to ASTM B 117-73
- Inside Surface finish(Ra 0.4-6.6um) to minimize friction and to maximize the life of actuator.
- Standard Applications for temperature ranges from -4°F (-20°C) to +180°F (85°C)
- Special options for extreme temperatures (upon request)
- Piston bearing made of material with low friction coefficient (LAT LUB) to avoid metal to metal contact, easily replaceable for maintenance.
- Double lower drilling, for valve mounting, and centering, according to ISO 5211/DIN 3337 standards.
- Top drilling for fastening of the accessories and upper shaft end according to NAMUR standards.
- Direct mounted solenoid connections according to NAMUR standards
- Independent travel stop adjustment of 4 ° in both directions.
- Lower female shaft key, according to ISO 5211/ DIN 3337 standards, for assembly on valves with star shaft.
- Same body and end cap for double acting and SVring return.
- Air supply: dry or lubricated filtered compressed air; pressure: min. 14.5 PSI-145 PSI
- The Lubrication carried out by the manufacturer is guaranteed for min 1,000,000 operations.
- Running test and 100% seal test carried out with electronic equipment and certification of each product.
- Position indicator.



SIMCO
Valve Company, Inc. **SVG**

151 Memorial Drive, Unit A
Shrewsbury MA 01545
Toll Free: 1-866-59SIMCO (866-597-4626)
Phone: 508-845-3300 Fax: 508-845-3304
info@simcovalve.com www.simcovalve.com

SERIES SV - PNEUMATIC RACK AND PINION ACTUATOR

Materials of Construction	
Body	Aluminum alloy, extruded according to ASTM 6063, anodized according to UNI 4522
End Cap	Die-Cast in aluminum alloy ASTM B179, painted with epoxy-polyester powder.
Pistons	Die-Cast in aluminum alloy ASTM B179.
Pinion	Nickel-plated steel.
Pinion Bearings	Acetal Resin (LAT LUB 731 320T) + 20% PTFE.
Screws	Stainless steel AISI 304
Springs	Precompressed cartridge, painted with epoxy powder.
Seals	Nitrile rubber NBR (VITON or EPDM on request).
Standard Grease	MoS2.
Optional Grease	Molykote.

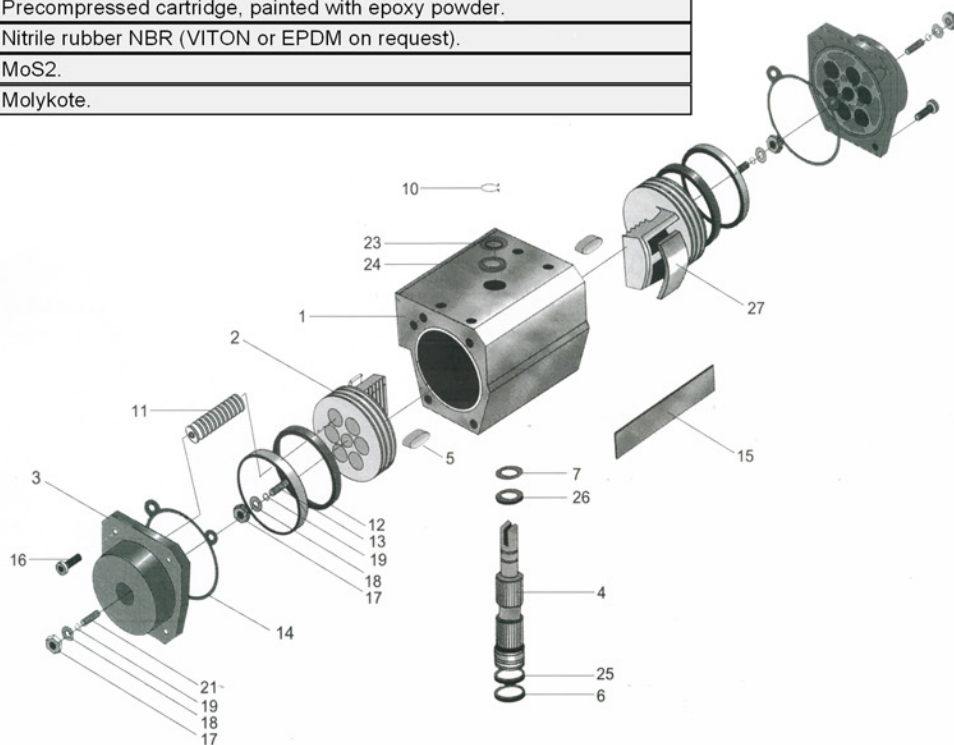

Part No.	QTY.	Description
1	1	Body
2	2	Piston
3	2	End Cap
4	1	Pinion
5	2	Piston Pilot Key
6	1	Pinion Lower O-Ring
7	1	Pinion Upper O-Ring
10	1	Retaining Ring
11	6-12	Spring Cartridge
12	2	Piston O-Ring
13	2	Piston Bearing
14	2	End Cap Gasket
15	1	Name Plate
16	8	End Cap Screw
17	4	Nut
18	4	Washer
19	4	O-Ring
21	2	Travel Stop
23	1	Pinion Thrust Washer
24	1	Thrust Bearing
25	1	Lower Pinion Bearing
26	1	Upper Pinion Bearing
27	2	Piston Bearing
28		Piston Screw

SIMCO
Valve Company, Inc. **SVG**

151 Memorial Drive, Unit A
Shrewsbury MA 01545
Toll Free: 1-866-59SIMCO (866-597-4626)
Phone: 508-845-3300 Fax: 508-845-3304
info@simcovalve.com www.simcovalve.com

SERIES SV - PNEUMATIC RACK AND PINION ACTUATOR

Optional Corrosion Protections

Coating with Chemical Nickel Having High Phosphorous Content

Nickel Deposits without electricity are produced by the chemical reaction of nickel in metallic substrate, without using electricity. Dead holes, threads, grooves, recesses or inside surfaces receive the same plating quantity as the sharp angles, the corners or the flat surface(20-30 um). The standard degree is approximately 45-55 Rockwell C and offers a good resistance to corrosion in salty fog. Please take care not to damage the surface by scraping, since this exposes the basic material to corrosion. (on request, the pistons may also be nickel coated.)

Strong Anodized Protection

The electrical process produces a thick anodized coating up to 50 microns. The resulting part resists corrosion from dipping and SVrays of sodium and chlorine and also corrosive cracking stress. The oxide coating is perfectly adherent and will not chip, even after sudden temperature changes or at temperatures equal to aluminum melting point. Aluminum oxide is one of the hardest known materials: 45-65 Rockwell C.

Epoxy-Polyester Coating

Epoxy coating is a deposit of powders on clean and sandblasted pieces. The chemical process is easily kept under control after coating, the pieces must be subjected to heat treatment. Epoxy painting of actuators is advised where environment is strongly aggressive. With a normal thickness of 200?250 microns of epoxy coating, resistance to salty fog exceeds 1,000 hours. With the exception of certain solvents, epoxy coating must not be scratched. (SVrings have standard coating.)

Actuation Sizing Guide

The seat material used, media, temperature, frequency of operation and criticality of the valve's operation are all important factors in calculating the actuation needs of a given valve. The information provided below should be considered as a guide only and must be adjusted according to experience and judgment. Proper actuator selection is required to prevent valve or process equipment damage as well as proper valve operation.

In general, we can say that valve torque results from the friction between the ball and seats as well as the stem and stem seals.

Valve Torque

The torque requirements of SimCo Ball Valves will vary depending on several factors.

- **Seat design and material**

SimCo seats are designed to ensure consistent sealing and low torque. The seat friction force depends on the seat material and the applicable **service factor** multipliers shown in the chart below

- **Stem Seal**

Torque results from the stem contact with stem seals. Packing materials affect torque. Stem seal torque is a high percentage of overall torque especially in small valve sizes.

Service Conditions

- | | |
|---------------------------------|-----------------------------------|
| • Differential Pressure | Minimum and maximum pressures |
| • Frequency of Operation | Stuck valve torque |
| • Media Influence | Slurries, dry gases, oils |
| • Temperatures | Minimum and maximums |
| • Cycle Time | Line hammer, process requirements |
| • Instrument Air Supply | Peak demand pressure availability |

Media and Service Factors

To establish minimum torque requirements, multiply valve torque by following application media and service factors.



151 Memorial Drive, Unit A
Shrewsbury MA 01545
Toll Free: 1-866-59SIMCO (866-597-4626)
Phone: 508-845-3300 Fax: 508-845-3304
info@simcovalve.com www.simcovalve.com

SERIES SV - PNEUMATIC RACK AND PINION ACTUATOR

Media Factors	Multiplier
Clean particle free, non-lubricating (water, alcohol or solvents)	1.00
Clean particle free, lubricating oil	.80
Slurries or heavily corroded and contaminated systems	1.30 to 2.00
Gas or saturated steam, clean and wet	1.00
Gas or superheated steam, clean and dry	1.30
Gas, dirty unfiltered e.g. natural gas, Chlorine	1.20 to 1.50

Service	Multiplier
Simple On and Off Operations	1.00
Throttling	1.20
Positioner Control	1.50
Once per day session	1.20
Once every two days or more or plant critical	1.50

Ball Valve

Ball valve construction concept is based essentially on a polished ball (including a through port) contained in two seats (upstream and downstream). The ball rotation allows the flow or stops the flow through the valve. Differential pressure between upstream and downstream pressure forces the ball against the downstream seat (floating ball). In this case, the valve torque is generated by the friction between ball and seat and also between stem and packing. As shown in the diagram to the right the highest torque point is when, in presence of pressure, the valve is in the closed position, and passes to the open position (breakaway torque).

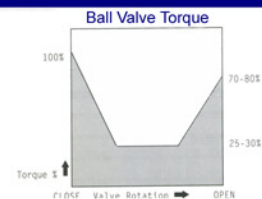

Butterfly Valve

Butterfly valve construction concept is based essentially on a disc fixed on an axis, which in the closed position, is completely contained by the seat. The open position is obtained when, with a rotation, the disc (through its stem) becomes parallel to the flow. On the contrary, the closed position is obtained when the disc is perpendicular to the flow. In the case of the butterfly valve, the torque is generated by the friction between the disc and the seat, by the stem packing and also by the differential pressure that forces on the disc. The highest torque point, as shown in the diagram, is in the closed position, and only after a small rotation it is considerably reduced.

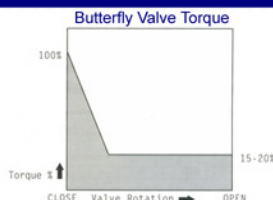

Plug Valve

Plug valve construction concept is based essentially on a male (plug) contained in a female cone (seat). The plug provides a through port in one direction and with its rotation into the seat the opening and closure of the valve is obtained. The torque is usually not influenced by the flow pressure, but is generated essentially by the friction between the seat and the plug, during the opening and closing cycle. As shown in the diagram to the right, the highest torque point is in the closed position and remains high for the rest of the operation, because the torque is not influenced by pressure.

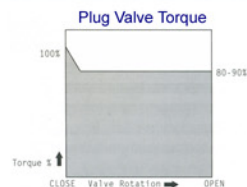

Double Acting Actuator (DA)

In the double acting actuators, the control pinion rotation and its reversal are obtained by reversing the supply to the two input ports. The output torques obtainable mainly depend on the cylinder diameter and the supply pressure; by increasing on or both factors the available torque also increases. The friction should usually be negligible. As shown in diagram A, the torque of a DA actuator is constant throughout the entire rotation and relevant reversal. The advised safety factor, in addition to the valve maneuver torque, is approximately 20%.

*Select the actuator size whose torque output at given pressure exceeds the valve torque and application factor.

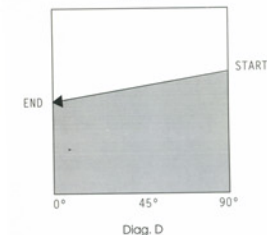
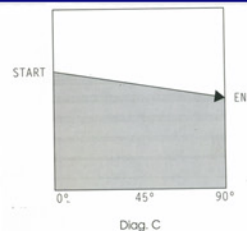

Recommended Spring Positioning

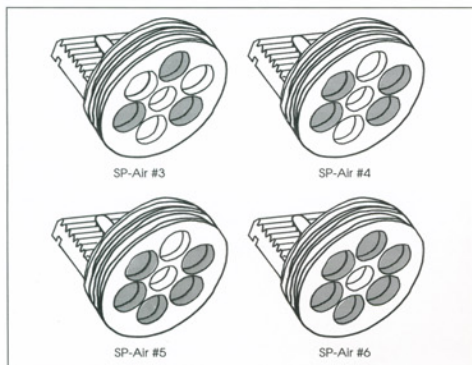

SIMCO
Valve Company, Inc. **SV**

151 Memorial Drive, Unit A
Shrewsbury MA 01545
Toll Free: 1-866-59SIMCO (866-597-4626)
Phone: 508-845-3300 Fax: 508-845-3304
info@simcovalve.com www.simcovalve.com

SERIES SV - PNEUMATIC RACK AND PINION ACTUATOR

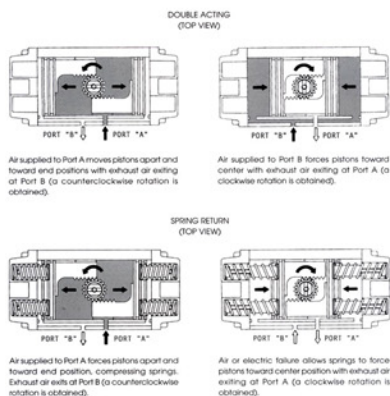

Air supplied to Port A moves pistons apart and toward end positions with exhaust air exiting of Port B (a counterclockwise rotation is obtained).

Air supplied to Port B forces pistons toward center with exhaust air exiting of Port A (a clockwise rotation is obtained).

Air supplied to Port A forces pistons apart and toward end position, compressing springs. Exhaust air exits of Port B (a counterclockwise rotation is obtained).

Air or electric failure allows springs to force pistons toward center position with exhaust air exiting of Port A (a clockwise rotation is obtained).

Reverse Rotation

Upon request, the pistons can be inverted in order to obtain a clockwise rotation when the air pressure is applied to Port A. Other types of assembly are possible: for any information, please contact SimCo Valves.

Quick Operation Actuators

Upon request, SV-AIR Series actuators can be specially prepared for fast response operations.

Spring Return Actuator (SR)

In these types of actuators, which utilize springs for reversing the rotation of the control pinion, the output torque depends not only on the cylinder diameter and the supply pressure, but also on the presence of the springs, which should be compressed to guarantee the return. As shown in diagram C, the available torque at 0° progressively reduces during the rotation due to the springs' compression. On the contrary, as shown in Diagram D, the torque starting from the 90° position constantly decreases until 0° because of spring extension. Owing to the higher friction present, the safety coefficient advised in this case is approximately 25%.

*Select the actuator whose torque output at 0° and 90° at a given air pressure exceeds the valve torque.

Upon request, the pistons can be inverted in order to obtain a clockwise rotation when the air pressure is applied to Port A. Other types of assembly are possible: for any information, please contact SimCo.

Quick Operation Actuators

Upon request, SV-AIR Series actuators can be Specially prepared for fast response operations.

Installation

- Make sure that the actuator, when fitted on the valve, is well aligned with the valve stem. When actuator is directly fitted with bracket and coupling, all parts must be precisely machined.
- In Spring return applications, the exhaust air port must be very well vented.
- Accessories, if any, must be mounted in a proper manner to allow unobstructed operation of the actuator.

Maintenance

- A. Remove the end cap screws of the end cap.
- B. Take off the end cap.
- C. Turn the pinion in clockwise direction so that the pistons come out of the body.
- D. Remove the retaining ring.
- E. Take the pinion out from the lower part of the body by simply pressing it with your fingers.
- F. Replace the following parts:
 - On the pistons:**
2 O-Rings; 2 bearings; 2 keys; 2 piston bearings; 2 O-Rings.
 - On the heads:**
2 gaskets; 2 O-Rings.
 - On the pinion:**
2 O-Rings; 1 bearing; 1 lower bearing; 1 upper bearing; 1 pinion thrust washer.

SIMCO
Valve Company, Inc. **SVCo**

151 Memorial Drive, Unit A
Shrewsbury MA 01545
Toll Free: 1-866-59SIMCO (866-597-4626)
Phone: 508-845-3300 Fax: 508-845-3304
info@simcovalve.com www.simcovalve.com

SERIES SV - PNEUMATIC RACK AND PINION ACTUATOR

Technical Features of SV-Air Series Actuators

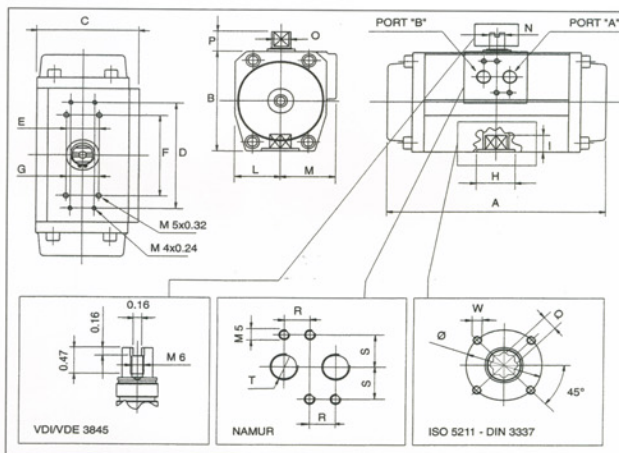

Dimensions in Inches

Dimensions (inches)

POSITION	ACTUATOR TYPE											
	SVO32	SV050	SVO63	SV075	SVO85	SV100	SV115	SV125	SV145	SV160	SV200	SV270
a	4.61	5.43	6.12	8.27	8.97	11.04	12.2	14.25	15.35	18.19	22.63	26.97
b	1.77	2.63	3.27	3.94	4.33	4.92	5.60	6.10	6.89	7.72	9.45	13.07
c	1.77	2.68	3.38	3.70	4.90	4.72	5.27	5.55	6.41	6.93	8.66	13.86
d	---	---	---	4.13	4.13	4.13	5.47	5.47	5.47	5.47	5.47	---
e	---	---	---	0.87	0.87	0.87	0.87	0.87	0.87	0.87	0.87	---
f	1.97	3.15	3.15	3.15	3.15	3.15	35.12	5.12	5.12	5.12	5.12	5.12
g	0.98	1.18	1.18	1.18	1.18	1.18	1.18	1.18	1.18	1.18	1.18	1.18
h	---	1.18	1.38	1.38	1.57	2.16	2.16	2.16	2.75	2.95	3.94	4.09
l	0.39	0.51	0.63	0.79	0.79	0.98	0.98	1.18	1.18	1.18	1.45	1.45
l	0.88	1.32	1.50	1.67	1.93	2.16	2.50	2.74	3.14	3.46	4.33	6.53
m	0.88	1.63	1.89	2.03	2.16	2.56	2.77	2.81	3.26	3.46	4.33	6.53
T-din 259	1/8"	1/8"	1/4"	1/4"	1/4"	1/4"	1/4"	1/4"	1/4"	1/4"	1/4"	1/2"
n	0.31	0.31	0.31	0.55	0.55	0.55	1.06	1.06	1.06	1.06	1.26	2.16
o	0.47	0.47	0.47	0.71	0.71	0.71	1.42	1.42	1.42	1.42	1.65	3.15
p	0.79	0.79	0.79	0.79	0.79	0.79	1.18	1.18	1.18	1.97	1.97	1.97
r	0.47	0.47	0.47	0.47	0.47	0.47	0.47	0.47	0.47	0.47	0.47	---
s	0.63	0.63	0.63	0.63	0.63	0.63	0.63	0.63	0.63	0.63	0.63	---
diam 0	1.42	1.65	1.97	1.97/2.76	1.97/2.76	2.76/4.02	2.76/4.02	2.76/4.02	2.76/4.02	4.02/4.92	5.51	5.51
Q	0.35	0.43	0.55	0.67	0.67	0.87	0.87	1.06	1.06	1.06	1.42	1.42
w	M5	M5	M6	M6-M8	M6-M8	M8-M10	M8-M10	M8-M10	M10-M12	M10-M12	M16	M16
ISO 5211	F03	F04	F05	F05-F07	F05/F07	F07/F10	F07/F10	F07-F10	F10-F12	F10/F12	F12-F14	F14-F16

ACTUATOR TYPE											
SVO32		SV050		SVO63		SV075		SV085		SV100	
DA	SR	DA	SR	DA	SR	DA	SR	DA	SR	DA	SR
0.07	---	0.23	---	0.45	---	0.61	---	0.98	---	1.80	---
0.50	---	0.60	0.60	0.60	0.70	0.60	0.70	0.60	0.70	0.80	1.10
0.50	---	0.60	0.60	0.70	0.90	0.70	1.00	0.90	1.30	0.90	1.30
0.92	---	2.30	2.64	3.50	4.00	6.40	7.50	9.25	10.60	12.75	15.00



151 Memorial Drive, Unit A
 Shrewsbury MA 01545
 Toll Free: 1-866-59SIMCO (866-597-4626)
 Phone: 508-845-3300 Fax: 508-845-3304
 info@simcovalve.com www.simcovalve.com

SERIES SV - PNEUMATIC RACK AND PINION ACTUATOR

VALUE		ACTUATOR TYPE											
		SV115		SV125		SV145		SV160		SV200		SV270	
		DA	SR	DA	SR	DA	SR	DA	SR	DA	SR	DA	SR
Volume	IT.	2.80	---	3.70	---	4.90	---	8.00	---	14.20	---	22.20	---
open	SEC.	0.90	1.20	1.10	1.30	1.10	1.40	1.30	2.10	3.60	4.60	4.50	6.00
Closed	SEC.	1.10	1.60	1.10	2.10	1.40	2.00	1.60	2.60	4.60	6.10	4.50	6.00
Weight	SEC.	20.25	22.60	26.20	31.25	34.00	41.80	45.10	54.80	94.60	116.6	260.8	248.6

Actuator Model	Double Acting Torque Rating (LB - IN)							
	Air Supply in P.S.I.							
	40 P.S.I.	50 P.S.I.	60 P.S.I.	70 P.S.I.	80 P.S.I.	90 P.S.I.	100 P.S.I.	
SV 032 DA	---	---	45	53	61	69	77	
SV 050 DA	74	93	112	131	150	169	187	
SV 063 DA	134	168	202	235	267	300	333	
SV 075 DA	285	357	428	499	570	642	714	
SV 085 DA	433	543	653	760	867	978	1088	
SV 100 DA	661	839	1016	1184	1351	1523	1694	
SV 115 DA	1114	1241	1368	1799	2229	2512	2794	
SV125 DA	1465	1950	2435	2684	2932	3304	3676	
SV 145 DA	2128	2666	3204	3731	4257	4798	5338	
SV 160 DA	2883	3613	4343	5055	5766	6499	7231	
SV 200 DA	5405	6772	8138	9475	10812	12184	13556	
SV 270 DA	13239	16585	19930	23204	26478	29839	33200	

ACTUATOR MODEL	# SPRINGS EACH SIDE	Spring Return Torque Ratings (IB - IN)																	
		AIR SUPPLY IN P.S.I.																Spring Stroke	
		40 P.S.I.		50 P.S.I.		60 P.S.I.		70 P.S.I.		80 P.S.I.		90 P.S.I.		100 P.S.I.					
AIR START	AIR END	AIR START	AIR END	AIR START	AIR END	AIR START	AIR END	AIR START	AIR END	AIR START	AIR END	AIR START	AIR END	AIR START	AIR END	SPRING START	SPRING END		
SV 050 SR	3							102	82	120	98	138	116	158	136	50	31		
	4	46	28	68	50	81	60	92	65	109	82	127	98	147	120	68	41		
	5			58	35	70	42	82	49	98	65	116	81	137	103	85	51		
	6							71	33	88	48	105	64	117	86	101	62		
SV 063 SR	3							174	147	229	176	288	208	329	246	90	63		
	4	76	51	113	89	136	107	152	118	206	146	264	176	299	216	121	86		
	5			94	63	118	76	131	88	185	116	242	145	278	186	141	107		
	6							111	59	164	68	220	114	251	157	181	128		
SV 075 SR	3							393	308	459	371	528	438	605	486	199	111		
	4	183	107	261	186	313	223	357	244	422	305	490	337	569	410	265	149		
	5			229	129	274	154	321	180	385	238	451	300	533	334	333	186		
	6							285	116	347	172	413	231	495	257	393	224		
SV 085 SR	3							600	466	700	561	806	662	925	786	305	167		
	4	281	154	400	280	480	336	546	367	615	459	748	557	865	686	408	223		
	5			351	192	422	230	492	269	589	358	691	451	815	585	510	279		
	6							440	171	534	256	633	346	755	485	612	334		
SV 100 SR	3							929	730	1086	879	1249	1036	1432	1228	471	265		
	4	433	244	617	440	740	528	844	579	997	722	1158	874	1341	1074	628	354		
	5			541	305	640	366	758	427	908	565	1066	711	1263	919	785	443		
	6							673	276	820	408	975	549	1170	765	942	532		
SV 115 SR	3							1504	1235	1761	1483	2030	1744	2333	2060	746	469		
	4	686	431	993	754	1181	905	1352	995	1604	1234	1868	1486	2178	1814	955	626		
	5			857	539	1029	647	1201	755	1447	985	1706	1228	2024	1569	1244	782		
	6							1049	515	1290	736	1544	971	1869	1324	1493	939		
SV 125 SR	3							2029	1574	2369	1898	2726	2238	3121	2656	1035	564		
	4	951	518	1351	946	1622	1135	1847	1241	2181	1544	2531	1881	2935	2316	1377	753		
	5			1187	649	1424	779	1665	909	1992	1208	2335	1524	2749	1977	1725	941		
	6							1483	576	1803	863	2141	1168	2563	1637	2070	1130		
SV 145 SR	3							2861	2284	3346	2754	3860	3251	4442	3862	1500	910		
	4	1297	755	1885	1377	2262	1653	2569	1810	3043	2138	3547	2484	4142	3369	2000	1219		
	5			1624	946	1948	1135	2275	1327	2739	1759	3232	2216	3844	2876	2500	1518		
	6							1983	844	2435	1259	2918	1699	3544	2456	3000	1871		
SV 160 SR	3							3927	3159	4592	3796	5292	4468	6072	5288	1970	1175		
	4	1811	1080	2602	1917	3123	2300	3546	2524	3140	3140	4886	3790	5686	4642	2627	1567		
	5			2264	1350	2717	1621	3170	1891	2483	2483	4482	3110	5301	3995	3284	1959		
	6							2793	1257	3417	1827	4076	2432	4915	3348	3941	2351		
SV 200 SR	3							7419	5866	8667	7059	9981	8319	11413	9864	3753	2420		
	4	3451	2225	2924	3542	5908	4250	6729	4658	7951	5808	9238	7025	10716	9627	5001	2858		
	5			4313	2463	5116	2956	6039	3450	7237	4557	8502	5731	10038	7395	6255	3574		
	6							5348	2242	6523	3306	7764	4436	9331	6162	7506	4289		
SV 270 SR	3							17163	15374	20182	18331	23368	21453	26999	25174	8147	6295		
	4	7491	5788	10896	9574	13075	11489	15137	12753	18084	15526	21198	18644	24982	22499	10952	8394		
	5			9441	7236	11329	8683	13110	10130	15986	12899	19028	15834	22865	18863	13579	10492		
	6							11084	7508	13887	10183	16856	13025	20717	17185	16295	12591		



151 Memorial Drive, Unit A
 Shrewsbury MA 01545
 Toll Free: 1-866-59SIMCO (866-597-4626)
 Phone: 508-845-3300 Fax: 508-845-3304
 info@simcovalve.com www.simcovalve.com

SERIES SV - PNEUMATIC RACK AND PINION ACTUATOR

ACTUATOR MODEL	DOUBLE ACTING	SPRING RETURN	NO.OF SPRINGS PER SIDE OF PISTON	OPTIONS
SV032	DA	SR	3	1= High Temperature Actuator
SV050			4	2= Coating with Chemical Nickel
SV063			5	3= Strong Anodized
SV075			6	4= Epoxy Coatings
SV085				
SV100				
SV115				
SV125				
SV145				
SV160				
SV200				
SV270				



151 Memorial Drive, Unit A
Shrewsbury MA 01545
Toll Free: 1-866-59SIMCO (866-597-4626)
Phone: 508-845-3300 Fax: 508-845-3304
info@simcovalve.com www.simcovalve.com