

Your Premiere Source For Quality Valve Products

Series #DM53 - Ball Valve - 3 Piece Full Port

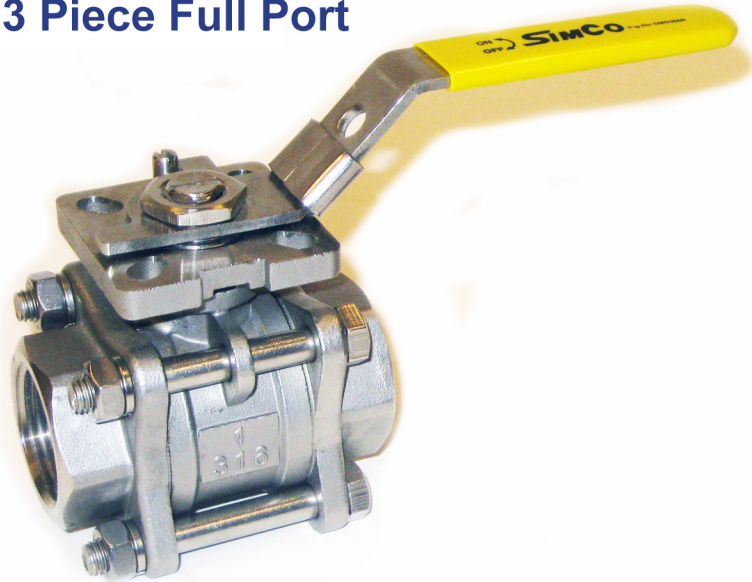

Features & Benefits

Full Port Design

Improves flow resulting in increased process efficiencies.

3- Piece Design

Easy to repair. Swing-out center section allows easy access to internal valve components without disturbing alignment of pipe.

ISO 5211 Direct Mounting Pad

Provides for precise shaft alignment and eliminates the need for brackets and couplings.

Adjustable Live Loaded Stem

Blow-out Proof Stem

Investment Cast

Improved dimensional control and reduces porosity.

Locking Handle

Pressure & Temperature Chart

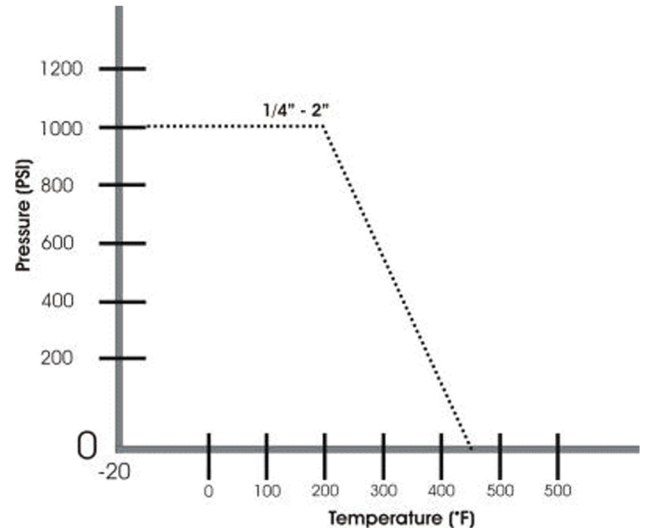

Operating/Test Conditions

Temperature Range (RTFE)

-20° F to 450° F

1000 W.O.G.

Test and inspection to API 598

ANSI/ASME B16.11

ISO 5211

MSS SP25, SP72

Options

Available in 316 Stainless Steel Construction ASTM A351-CF8M

Available in Carbon Steel Construction ASTM A216-WCB

End Connections available in:
 NPT, Socketweld

Schematic Diagram

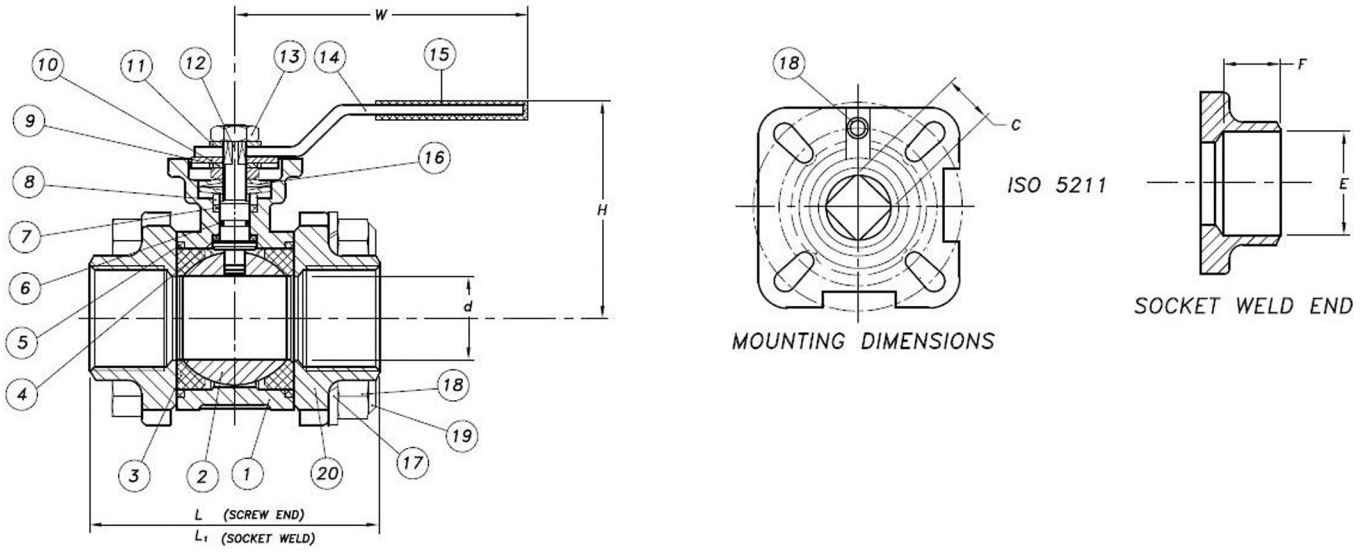

Materials & Measurements

SIZE	ød	L	L ₁	H	W	ISO 5211	C	F	E	Torque (in lbs)
1/4"	.43	1.85	1.69	2.32	4.73	F03	.35	.39	.56	36
3/8"	.50	1.85	1.69	2.32	4.73	F03	.35	.39	.67	36
1/2"	.59	2.13	2.13	2.48	4.73	F03	.35	.39	.85	45
3/4"	.79	2.88	2.88	2.76	5.52	F04/F05	.43	.55	1.07	71
1"	.99	3.09	3.15	2.92	5.52	F04/F05	.43	.55	1.33	89
1 1/4"	1.26	3.55	3.55	3.47	8.04	F05/F07	.55	.59	1.67	124
1 1/2"	1.58	4.02	4.02	3.70	8.04	F05/F07	.55	.59	1.91	160
2"	1.97	4.65	4.65	4.02	8.04	F05/F07	.55	.75	2.41	222
2 1/2"	2.56	5.87	5.99	5.52	10.05	F07/F10	.67	.83	2.91	425
3"	3.15	7.09	7.09	6.03	10.05	F07/F10	.67	.95	3.54	664
4"	3.94	8.75	8.59	6.54	11.90	F07/F10	.67	.95	4.54	974

ITEM	PARTS	MATERIAL
1	Body	CF8M WCB
2	Ball	316SS
3	Ball Seat	REIN. PTFE (15%)
4	Thrust Washer	316SS
5	Body Gasket	PTFE
6	O-ring	VITON
7	Stem Packing	PTFE
8	Gland	304SS
9	Tab Washer	304SS
10	Stopper	304SS
11	Spring Washer	304SS
12	Stem	316SS
13	Nut	304SS
14	Handle	304SS
15	Handle Sleeve	PLASTIC
16	Belleville Washer	301SS
17	Spring Washer	304SS
18	Nut	304SS
19	Bolt	304SS
20	Cap	CF8M WCB
21	Stop Pin	304SS

How To Order

Valve Size	Valve Series	Body	Ball & Stem	Seat	Ends
1/4" - 4"	DM53 = 3 PC Direct Mount	6 = 316 4 = Carbon Stl.	6 = 316	R = RTFE	SW = Socket Weld TE = NPT

Due to continuous product development, information may change without notice.