

ELECTRIC SERIE



The heavy series electric shutters represent an advanced and highly automated solution for access control.

Thanks to the electrical control, they offer continuous operation and can be easily integrated into more complex automation systems.

The possibility of programming, synchronization with the working machine and remote control make them ideal for commercial and industrial applications.

Flexibility and operational efficiency make electric dampers an excellent choice for environments where precise control and centralized management is required. They are recommended on plants with passage of a lot of material and high depressions. The dampers are supplied standard with edges, protective casing and actuator included.

TECHNICAL DATA

- Available dimensions: Ø80 ÷ Ø500
- Maximum speed of air: 35 m/s
- Maximum working depression: 500 mmH₂O
- Working temperatures: -20°C ÷ 80°C
- Speed of closure: 10 mm/s
- Specifics electric actuator: see table below

Specifics electric actuator		
Shutter's size	Ø80÷280	Ø300÷600
Model of actuator	MAX	MAX
Nr. Actuators	1	2
Actuator's Torque [N]	450	450
Power [W]	35	35
Voltage [V]	230V AC 50Hz or 24V DC	230V AC 50Hz or 24V DC
Type of wiring	4 wires (3P + N)	4 wires (3P + N)

DIMENSIONS

Ø [mm]	Mass [kg]	A [mm]	B [mm]	C [mm]	D [mm]	E [mm]	Body Thickness [mm]	Diaphragm Thickness [mm]
80	8	220	415	861	228	105	3,0	3,0
100	9	220	415	861	228	105	3,0	3,0
120	10	270	565	1031	278	105	3,0	3,0

140	12	270	565	1031	278	105	3,0	3,0
150	13	270	565	1031	278	105	3,0	3,0
160	14	270	565	1031	278	105	3,0	3,0
180	15	320	715	1181	328	105	3,0	3,0
200	17	320	715	1181	328	105	3,0	3,0
220	19	370	765	1231	378	105	3,0	3,0
240	21	370	765	1231	378	105	3,0	3,0
250	23	370	765	1231	378	105	3,0	3,0
260	24	370	765	1231	378	105	3,0	3,0
280	27	420	1015	1481	565	105	3,0	3,0
300	28	420	1015	1481	565	105	3,0	3,0
350	39	470	-	1163	615	283	3,0	3,0
400	47	520	-	1213	665	283	3,0	3,0
450	55	570	-	1363	715	283	3,0	3,0
500	64	620	-	1413	765	283	3,0	3,0

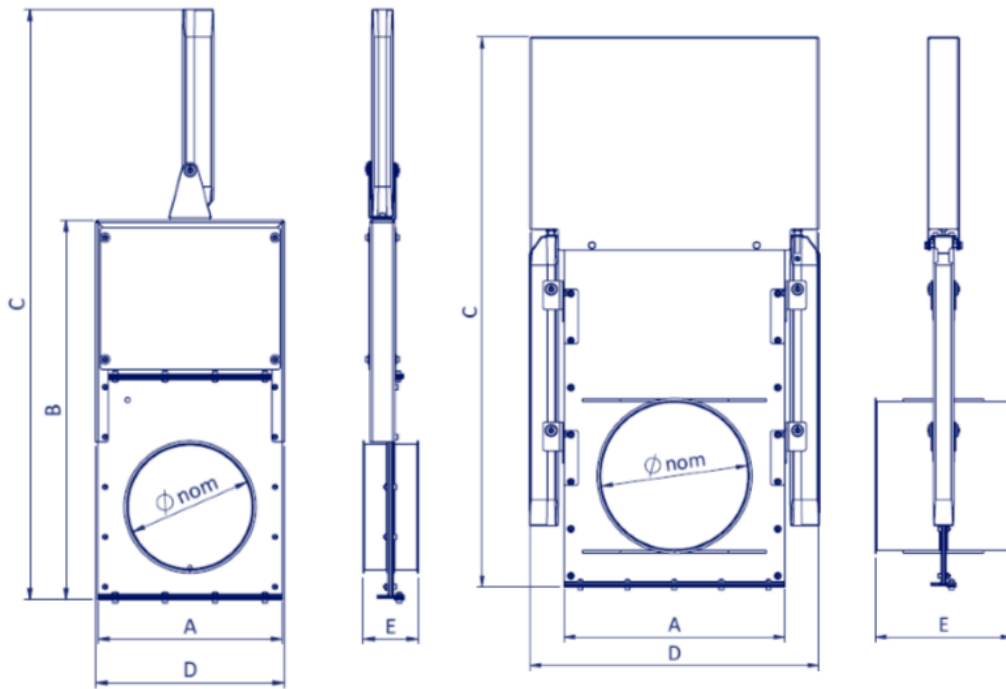

Ø80 ÷ Ø300

Ø300 ÷ Ø500

CHARACTERISTICS ON REQUEST

- ⊙ Other materials: Stainless Steel INOX AISI 304 or AISI 316
- ⊙ Other edges: Smooth edges
- ⊙ Additional equipment: Smooth flanges or Pressed flanges
- ⊙ **Available upgrades:**
 - Position Sensor