

TAURUS

Cutting edge technology for high performance 3-phase UPS



10kVA ~ 80kVA

Delivering clean, stable and reliable power for critical three-phase loads, Taurus is the best choice for small data centres. And with a simplified maintenance helps reducing the TCO of the installation.

Features

- Cutting edge technology: Power Factor 1, 96% efficiency, 3 level IGBT, troubleshooting and testing in safety low voltage
- Operates leading and lagging loads without derating
- Generator compatibility with ramp up configurable in power and time delay with wide input frequency range
- Lift compatibility to efficiently use re-injected energy from generative loads
- THDi <3% for a minimized grid impact
- Cold start (standard up to 20kVA, optional up to 80kVA)
- UPS information, settings and log file easily downloadable on removable SD card from LCD to simplify service operations
- Two strings of internal batteries up to 40kVA
- Wide range of battery number per string from 32 to 40 LCD settable (26-40 for 10kVA)
- Ready for Li-ion or other battery technology
- Smart Battery Detection - immediate alarm once battery disconnected
- Smart Battery Discharge - For Battery Discharge Test without extra loads and connections
- Dual input and internal manual bypass
- Parallelable up to 6 units, in power or redundancy, LCD settable
- Separate or common batteries for parallel systems
- Touch screen color LCD display for quick and user friendly operation
- Wide communication offer as a standard: two com slots, RS232, USB, programmable dry contacts
- Wrong phase sequence rotation protection
- Flexible High Power charger
- 440mm wide fits into higher IP cabinets
- Strong overload capacity (<200ms for > 150% overload) to guarantee selectivity in the downstream installation

Options

- SNMP, RS485, Modbus board
- External temperature sensor
- Internal battery trays for simplest battery inspection or replacement
- Parallel kit
- Internal isolation transformer (up to 40kVA)
- External battery cabinets



Small data centre



Networking



Healthcare



Industry



Lift

Smart Functions

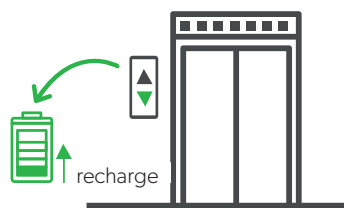

Optimised lift compatibility



Smart battery detection

Discover More



Technical Specifications

Model		TS10-0000	TS20-0000	TS30-0000	TS40-0000	TS60	TS80
Input	Voltage	400V 3-phase + N					
	Voltage Tolerance	±20% @ full load, -40% @ 50% load					
	Frequency	40~70Hz (independent from output frequency setting)					
	Power Factor	≥ 0.99					
	THDi	<3%					
Output	Voltage	380/400/415V 3-phase + N					
	Voltage Tolerance	±1% (static load)					
	Power Factor	1					
	Frequency	50/60Hz					
	Frequency Tolerance	±0.01% (free running)					
	Crest Factor	3:1					
	Voltage Harmonic Distortion	<1% with linear load; <3% with distorting load					
	Overload	110% for 60 minutes, 125% for 10 minutes, 150% for 1 minutes, >150% for 200 minutes					
Battery	Number	26~40pcs conf.		32~40pcs configurable			
	Charging current Max (A)	7A	14A	20A	26A	40A	52A
	Common battery for parallel configuration	Yes					
Efficiency	VFI Mode	Up to 96%					
	ECO Mode	>98%					
Bypass	Voltage	380/400/415V 3-phase +N					
	Voltage Tolerance	±5%~±25% (alarm programmable)					
	Frequency	50/60Hz					
	Frequency Tolerance	±1Hz/±3Hz (selectable)					
General	Parallel	Up to 6 units					
	Dimensions (WxDxH) mm	440 x 840 x 1390			600 x 827 x 1300		
	Weight (kg)	84	86	130	132	200	210
	Protection Grade	IP20					
	Display and MMI	4.3'' color LCD touch screen					
	Built-in Communication Port	USB, EPO, 2 SNMP slots, 1 IN/3 OUT dry contacts					
	Optional Communication	RS232, RS-485 modbus card, extra dry contact card					
Environment	Operation Temperature	0~40°C					
	Operation Humidity	0~95% (without condensation)					
	Tested to standards	IEC EN 62040-1, IEC EN 62040-2, IEC EN 62040-3					
	Mark	CE					
	Noise Level	<52dBA @ 1 metre		<55dBA @ 1 metre		<60dBA @ 1 metre	

Power Connections

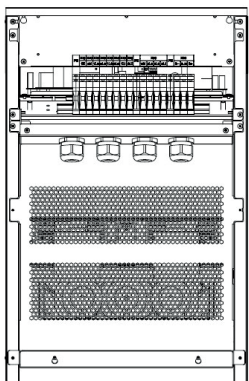

Back Panel - Terminal
TS10-0000/ TS20-0000

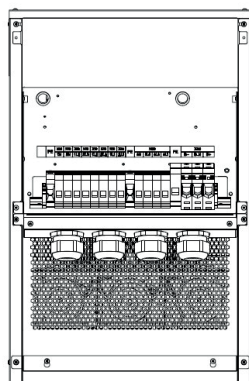

Back Panel - Terminal
TS30-0000/ TS40-0000

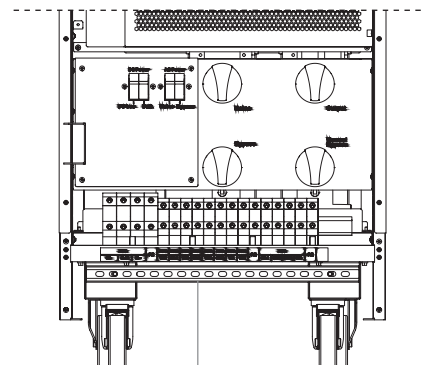

Front Panel - Terminal
TS60/ TS80

Specifications subject to change without notice

Discover More

