



N R C

NATIONAL ROBOTICS CHALLENGE

1986 to 2026

**40 YEARS
OF AWESOME**

April 16-18, 2026

Marion, Ohio

www.thenrc.org

(Updated 2/27/26)

1986 - 2026

40 years of open-robotics

*The longest continually
operating robotics competition
in the world!*

Contest Sponsors

We would like to thank our contest sponsors. Without their financial and in-kind contributions this event would not be possible.

Premier Corporate Sponsor (> \$20,000)



ArcelorMittal
Marion, Ohio

Sustaining Partner (\$5,000 - \$10,000)



HONDA

The Power of Dreams

Contributing Partners



Table of Contents

OFFICIAL RULES AND REGULATIONS6
General Competition Information8
Dr. James Hannemann Leadership and Service Award11
Parent/Student Authorization Form12
Contest Complexity Guide.....13
Additive Manufacturing Challenge14
Autonomous Vehicle Challenge (AVC)18
Box Bot.....23
Combat Robot.....29
Manufacturing Workcell.....37
Micromouse Contest40
Mini-Sumo Robot.....44
Rescue Robot47
Robo Hockey.....50
Robot Maze Contest.....53
Robot Problem Solving.....58
Sumo Robot59

Every attempt has been made to publish an accurate Contest Manual. However, updates and new information becomes available on a regular basis.

For the most current information and announcements, please refer to the contest web site:

www.thenrc.org

OFFICIAL RULES AND REGULATIONS

INTRODUCTION

The National Robotics Challenge began in 1986 as the Robotics International of the Society of Manufacturing Engineers (RI/SME) Robotic Technology and Engineering Challenge (RI/SME-RTEC). RI/SME-RTEC was developed under the guidance and inspiration of Tom Meravi, Associate Professor from Northern Michigan University and the late Dr. James Hannemann, co-chairman of the event. RI/SME-RTEC moved to Marion, Ohio in 2004 under the guidance of Ed Goodwin, Ritch Ramey and Tad Douce. In 2005 the contest was renamed the National Robotics Challenge. From this humble beginning, with two workcells and two pick and place competitions, the 2026 competition offers twelve exciting contest categories.

The National Robotics Challenge is designed to provide students of all ages and levels of study the opportunity to demonstrate their knowledge and understanding of manufacturing processes, controls, robotics, and other technologies through competitive engineering contests. Students are judged on their application of technology principles, engineering concepts, and their ability to solve real-world problems through a team approach.

The National Robotics Challenge is designed to complement classroom instruction and provide students the opportunity to apply classroom knowledge in challenging and fun situations. Each contest is specifically designed to test the students' skills and knowledge in a particular area of manufacturing, technology, robotics, and automation. The event is open to any student in elementary, middle school, high school, or post-secondary school anywhere in the world.

Last year, over 1400 participants from 18 states and Puerto Rico competed in the NRC. Our vision is to become the premier robotics competition for elementary, middle, high, and post-secondary school students around the globe.

MISSION

The mission of the National Robotics Challenge is to provide educational robotics competitions where students can develop the creativity, engineering, problem-solving, and leadership skills they will need in the world of tomorrow.

GENERAL INFORMATION

The 2026 competition is Thursday, Friday, and Saturday, April 16, 17 & 18, 2026.

Registration costs: \$85 per team/school plus \$20.00 per robot

Registration must be received no later than Friday, February 27th, 2026.

Unless otherwise noted in the contest rules, each school can enter a maximum of twenty (20) robots in a single contest category. ie. Middle School-Mini-Sumo

All registration will be completed online.

The registration link will be available on the National Robotics Challenge website (www.thenrc.org) by Monday, January 12th, 2026.

STAYING IN TOUCH

The National Robotics Challenge committee has several online tools to facilitate communication between the NRC Committee, Advisors, Student and Parents.

Facebook:

Become a fan of the National Robotics Challenge on Facebook. Search for “The National Robotics Challenge” or go to: www.facebook.com/TheNRC

Twitter:

Follow us on Twitter - @followNRC

YouTube:

www.youtube.com/nrcrobotv

CONTEST MANUAL

An updated version of the Contest Manual can be found on-line at the National Robotics Challenge website (www.thenrc.org) under the “Contest Manual” link.

There are **many** changes from last year’s contest manual. Every attempt has been made to highlight these changes with **(New for 2026)**. However, in order to ensure your team’s successful participation in this year’s event, **please review the contents of this manual carefully.**

Check the website often; it is your source for current information, updates, and changes.

General Competition Information

Contest Categories

The National Robotics Challenge is composed of twelve exciting contest categories. These educational activities are designed to provide students with an opportunity to demonstrate their knowledge and understanding of technology through a variety of contests. Each contest challenges student knowledge in a particular area of manufacturing, technology, robotics, and automation. A robot may only be entered in one contest category per year, unless otherwise noted in a contest category section of this manual.

Advisor Expectations

Advisors may not handle the robot at any time at the competition area. Advisors may only serve as a coach and should not actively engage with repair, programming, and/or operation of the robot. Any operation that involves the robot must be completed by a student.

Levels

Individual students and teams are invited to participate in the following divisions, based on the current academic level of the most senior team member:

Elementary

- Students enrolled in a public, private, or home school offering instruction less than middle school.

Middle School

- Students enrolled in a public, private, or home-school offering instruction between and including grades six, seven and/or eight.

High School

- Students enrolled in a public, private, or home-school offering instruction between and including grades nine, ten, eleven and/or twelve.

Post-Secondary

- Students enrolled in a public, or private school offering instruction at less than the baccalaureate level or a public or private school offering programs at or beyond the baccalaureate level (included community college, technical institute and university undergraduate and graduate students.)

Post-Secondary events:

- Autonomous Vehicle Challenge (AVC)
- Combat Robot (Beetleweight Only)
- Manufacturing Work cell
- Micromouse Contest
- Sumo Robot

Judging

All of the contests are ranked based on the criteria in this manual. Students are judged on their application of technological principles and concepts, and their ability to solve difficult problems through a team approach. During the judging for each contest, only the contest facilitator and judges/officials are permitted in the designated contest area. Instructors, team advisors, parents, and additional competition attendees are prohibited from entering into the designated contest area while judging is occurring. Concerns regarding, or objections to a judge's ruling must be brought to the attention of the Director of Contest Judging or Director of Events at the time of the contest judging. For all contests and special awards, the decisions of the judge(s) are final and binding.

Unique Robot Construction and Programming Policy

Eligibility Criteria:

Each robot entered into the competition must be the original work of the team currently using it. This means that the robot, including all hardware and software components, must be constructed and programmed by the team members currently registered for the competition.

Pre-Built and Previously Used Robots:

Robots that were designed, built, or programmed by any team other than the current team are prohibited. Any team of students competing in the same contest category for multiple years is expected to completely redesign or make changes to their entry so the judges can clearly recognize the iterative improvements made since the prior year's entry.

Inspection and Compliance:

A technical inspection will be conducted to verify compliance with this rule.

This inspection will include a review of software code and hardware construction, including verification of original work through component marking and design verification. Teams must bring documentation of their design process and the iterations that have taken place during the current school year. (ie. Engineers Notebook or Portfolio)

Penalties:

Violation of this policy may result in the robot being disqualified from competition.

Purpose:

This rule is designed to ensure that all teams have an equal opportunity to succeed based on their own creativity and effort, maintaining the integrity and fairness of the competition.

Awards

Awards for each contest are presented on the following levels: Gold, Silver, and Bronze

Honda Innovation Award

This award will be presented to the team with the most creative/innovative design that exemplifies Honda values. The judging team will nominate one team from each category for this award. A panel of award judges will analyze each nominated team and then select a winner. Each team that was nominated will receive a plaque, and the winning team will receive a trophy/plaque and a \$500.00 check for their school.

Safety and Liability

The National Robotics Challenge organization, staff, committee, competition sponsors, competition facilitators and/or judges/officials may stop the operation of any contest or special award participant if it is determined that the operation of the entry is hazardous. Such stoppage may disqualify the participant from that portion of the competition. Each contestant is responsible for his/her own personal safety and safety equipment. EduEverything, Inc. assumes no financial or organizational liability through its role as a sponsor of the National Robotics Challenge. The National Robotics Challenge, EduEverything, Inc., and the Veterans Memorial Coliseum, Marion, Ohio, shall hold harmless the other party from and against all claims, suits or actions or injury or damage arising from any intentional or negligent act of the party's employees, agents, officers and/or authorized subcontractor(s) while performing duties needed for sponsoring this event.

Dress Code

The National Robotics Challenge showcases outstanding entries, students, instructors, programs, schools, and sponsors. Our judges and sponsors come from diverse professional organizations and they expect students to look and act like professionals. For this reason, we ask that you abide by the following dress code at this event:

- A. All participants, advisors, and chaperones must wear a collared shirt and pants at all times on the competition floor.
- B. A team or National Robotics Challenge t-shirt may be substituted for a collared shirt. (Teams are encouraged to develop a team shirt or uniform to wear during the event.)
- C. The following attire is not permissible at the National Robotics Challenge:

1. Shorts
 2. Cut-off pants
 3. Ripped, Distressed, or Destroyed Pants
 4. Torn clothing
 5. Overly baggy clothes
 6. Open toed shoes (safety concerns)
 7. Soiled clothes
 8. Hats (Official National Robotics Challenge hats may be worn during competition)
- D. Any individual who does not adhere to the above dress code will be asked to comply or be disqualified from his/her event(s).

Accessibility

The National Robotics Challenge is committed to providing reasonable accommodation to persons with a disability to facilitate their full participation in the National Robotics Challenge events. Please contact Tad Douce at 740-361-6772 at least one month prior to the National Robotics Challenge should such accommodations be required.

Financial Assistance

You should begin planning now to finance the cost of your participation and trip. The following are recommendations to obtain financial assistance:

Institutional Support

Request support from your school or university. Your Faculty Advisor/Instructor can help determine if your institution can pay for a portion or all of your expenses. **ASK YOUR FACULTY ADVISOR / INSTRUCTOR FOR HELP!**

Fund Raisers

Fundraisers are a good way to obtain the funds required to finance your trip. Students and communities are willing to “pitch-in” for a good cause. What is your cause? A challenging, educational experience that helps prepare you for your manufacturing future, and a chance to represent your school. Some ideas include: donut, bagel, bake or candy sales, car washes, community yard service, snow shoveling, lawn raking, senior citizen services, selling popcorn/candy at school sporting events, etc.

Local Service Organizations and Government Agencies

Check with your Faculty Advisor / Instructor to determine whether any community organizations, state or Federal government agencies, such as NASA, a local foundation, or service organization would be willing to donate a portion of the needed funds.

Local Companies

Is there a local manufacturing company that may be interested in sponsoring your trip? Perhaps they are willing to donate some of the needed equipment. Check with your Faculty Advisor for contact names.

Manufacturers and other Industry Partners

Manufacturers and industry partners are excellent contacts, which are often more than willing to get involved in a project of this type. Your Faculty Advisor/Instructor can provide a list of contacts.

Dr. James Hannemann Leadership and Service Award

James W. Hannemann Ph.D. (1937 – 2001)

Working behind the scenes, Dr. Hannemann volunteered his time and talents tirelessly for fifteen years helping the Robotic Competition grow, expand and develop into the competition it is today. From its humble beginnings in 1986, with two workcells and two pick and place competitions, the current competition offers contests for elementary to post-secondary students in a wide range of categories.

In recognition of Dr. Hannemann's years of service to the RI/SME Student Robotic Competition, now the National Robotics Challenge, and to the thousands of students he touched, the National Robotics Challenge has established the Dr. James Hannemann Leadership and Service Award. This award is given annually at the National Robotics Challenge awards ceremony.

2025 Dr. James Hannemann Leadership and Service Award Recipient

The directors of the National Robotics Challenge are pleased to announce that Mr. Gabe Oberlin from Patrick Henry received the 17th annual Dr. James Hannemann Leadership and Service Award.



Oberlin, a horticulture Tech Prep satellite instructor with Four County Career Center, serving students at Patrick Henry High School, is recognized for his leadership in founding and developing the NORTech Robotics Challenge, a pre-college robotics program that introduces middle and high school students to real-world engineering and technology through accessible, hands-on competition. The NORTech Robotics Challenge at Bowling Green State University is a regional event designed to prepare students for success at the National Robotics Challenge. By aligning NORTech's structure with NRC standards, expanding divisions to include younger participants, and fostering mentorship and resource-sharing among schools, Gabe has created an inclusive and impactful competition that builds student confidence and program capacity. His dedication to event planning, volunteer coordination, and advocacy for robotics as a powerful STEM learning tool has strengthened the robotics community and inspires the next generation of innovators.

The entire NRC team wishes to thank Gabe Oberlin and his entire team for their continued commitment to the NRC! Gabe's commitment to his fellow educators and the students they impact is truly inspirational. We wish him and his team continued success, and we look forward to seeing him at the NRC for many years to come!

Parent/Student Authorization Form

National Robotics Challenge Authorization Form – 2026

CONSENT, RELEASE, HOLD HARMLESS AND AUTHORIZATION TO REPRODUCE PHYSICAL LIKENESS

This form is required of all minors and adults who attend the National Robotics Challenge (NRC). Copies of this completed form are to be retained and kept on file by the minor's parents, advisors, and/or school administration. It is the responsibility of the advisor to make sure there is a completed form for each participant and to give a copy to the school administrator if necessary. The National Robotics Challenge reserves the right to request a completed copy of this form at any time from the chapter advisor or state advisor. Do not send this form to the National Robotics Challenge office.

As used below, NRC shall mean the National Robotics Challenge and its officers, directors, employees, assigns, and agents (including any third party designated and approved by the NRC) at any time, including, without limitation, individuals or entities involved in print, publication, television, broadcast, or video media. As used below, "Participant" shall mean any individual, student, advisor, teacher, or volunteer involved in an NRC activity. The participant in any NRC contest, program, meeting or conference (collectively, the "Event"), agrees to the following:

I hereby grant to the NRC the right to photograph and/or videotape me (my child) during my participation in an Event. I further grant to the NRC, forever and throughout the world, the right to use these photographs and videotapes of my likeness, voice and sounds during my participation, and to reuse or license the right to such photographs and videotapes of my participation, and my name, likeness and biography, as the NRC may desire, in all media and in all forms and for all purposes, including without limitation, advertising and other promotions for the NRC, without further compensation to me or any limitation whatsoever. In granting this license, I understand that the NRC is not under any obligation to exercise any of their rights, licenses and privileges herein granted. Each such photograph and videotape shall be a work for hire and the NRC shall be deemed the owner of any copyright and/or trademark rights therein (and all applications, registrations and renewals resulting there from). If, however, the work is deemed not to be a work made for hire by a court of competent jurisdiction, then this Consent and Release to Produce Physical Likeness ("Release") shall constitute an irrevocable assignment by the Participant of the worldwide copyright in the work to the NRC. It is an NRC policy not to print a minor's picture accompanied by his/her name unless the NRC has obtained specific permission from his/her parent or guardian.

The undersigned being fully cognizant of the risks in participating in an Event, hereby assumes the risks of bodily injury (including, without limitation, death) and property damage, inherent in such participation. Exception to the extent due to the gross negligence or willful misconduct of the NRC, to the fullest extent permitted by applicable laws, I hereby waive any claims or causes of action which I may now or forever have against the NRC arising out of my participation, and I will indemnify and hold harmless the NRC against any and all claims resulting from such participation.

I hereby release the NRC and its respective successors, affiliates, licensees and assigns from all claims, demands, liabilities, damages, costs and expenses (including, without limitation, attorney's and other professional fees and expenses) that I may now or ever have against the NRC arising in connection with my participation in the Event and the NRC's exercise of rights hereby granted, including, without limitation, claims for compensation, defamation, or invasion of privacy, or other infringements or violations of personal or property rights of any sort. In the event I should sustain injuries or illness while involved in an Event, I hereby authorize the NRC to administer, or cause to be administered, such first aid or other treatment and medications I may bring as may be necessary under the circumstances, to include treatment by a physician or hospital of the NRC's choice.

This Release shall be binding upon my heirs, personal representatives and assigns, and me and shall be governed by and construed under the laws of the State of Ohio without regard to conflicts of laws principles. Venue for any legal action arising out of or in connection with this Release shall be in Marion County, Ohio. This release constitutes the entire agreement among the parties hereto with respect to the subject matter of this Release and supersedes any and all previous agreements among the parties, whether written or oral, with respect to such subject matter. I understand that this form involves a release of legal rights. A parent or guardian agrees to all of these terms on behalf of a minor.

Participant's Name _____

Participant's Signature _____

School _____

Home address _____ City _____ State _____ Zip _____

Allergies _____

Current Medication _____

History of heart condition, diabetes, asthma, etc. _____

Physician's name and telephone _____

Insurance company and policy number _____





































Parent/Guardian's Name _____

Signature of Parent/Guardian of Minor Participant _____

Minor's Age _____

Parent's Phone _____ (h) _____ (c) Email _____

Contest Complexity Guide

Event	Mechanical Complexity	Electrical Complexity	Programming Complexity
Additive Manufacturing Challenge			
Autonomous Vehicle Challenge (AVC)			
Box Bot			
Combat Robot			
Manufacturing Workcell			
Micromouse			
Mini-Sumo Robot			
Rescue Robot			
Robo Hockey			
Robot Maze			
Robot Problem Solving			
Sumo Robot			

Additive Manufacturing Challenge

Middle School, High School, Post-Secondary

OFFICIAL CONTEST SPONSOR

Marion
Technical College

OVERVIEW

The goal of the Additive Manufacturing Challenge is to give students additional opportunities to experience simulated manufacturing projects. This event focuses on an additive manufacturing design with strict requirements on form, fit, and function of compact and intricate designs.

This contest has been designed to challenge students' understanding of and skills in Additive Manufacturing.

Participants use basic engineering techniques to evaluate designs they have modeled, 3D printed, and tested. Each team researches, designs, and tests models to determine superior engineering. Teams research, model, and test a structure designed to hold the greatest load. Each team is given the selected height to be tested and must plan, 3D print, and submit a model for destructive testing.

MATERIALS AND SUPPLIES NEEDED

Materials to be Provided by Student Competitor:

- Printed 3D designed structure
 - Structures can be submitted in person by 10:00 AM Eastern Time on Friday, April 17, 2026, at the National Robotics Challenge in Marion, Ohio, or they can be postmarked by March 27, 2026, and mailed/shipped to:
Brad Pottkotter
1825 Lee Rd.
Marion, Ohio 43302
- In addition to the printed structure, the following items must be submitted via this [FORM](#) by Monday, March 30, 2026.
 - Computer design rendering files in STL.
 - Digital Engineering notebook
 - Video Presentation showing structure in printing process and students describing why they made design choices specific to their submitted structure.

Note: If needed, students may have an online interview with a panel of judges to further evaluate their project.

Rules and Structure Specifications

Extrusion/ structure designs cannot be one solid piece or build. The design criteria for this year requires individual parts to be printed and brought to the NRC for assembly. No two single printed parts can be preassembled prior to the time designated by the judging team. Multiple parts can be printed simultaneously.

1. **(New for 2026)** 30 grams maximum weight for the entire structure
2. **(New for 2026)** Flat top and flat bottom. Both top and bottom must be a rectangular shape with a minimum of 4" in length and width. The minimum height is 4.5"
3. A 12-ounce soda can must be able to fit inside and pass through the structure.
4. Structure maximum dimensions are 6" deep x 6" wide x 5" height – meaning the entire structure must be able to be contained within these dimensions.
5. **(New for 2026)** 12 joints minimum – joints must be no larger than 3/4" x 3/4" x 3/4".
6. No glues or other adhesives are permitted – all members must be detachable from all joints.
7. The contest will require a design notebook.
 - 7.1. Must include STL file
 - 7.2. Drawing file of parts in PDF
 - 7.3. Video of 3-D print is required.
8. Permitted materials:
 - 8.1. PLA
 - 8.2. ABS
 - 8.3. Nylon
 - 8.4. PETG
9. The structure must support the 6" x 6" x 3/4" test block at the top of the structure.
10. Build material can be removed after the print is complete, but nothing may be added to the structure. *Sanding, filing, drilling, and reaming is permitted on 3d printed parts to help with assembly and removal of support material.*
11. Failure is considered deformation/compression to 4" or when whenever the pressure on the structure or any part of the structure fails, breaks, snaps, or visual cracking appears.

Evaluation

1. Testing

- 1.1. All structures are destructively tested by attaching a testing device of the coordinator's choice to the test block and adding resistance until the structure fails.
- 1.2. Structures are NOT tested if:
 - 1.2.1. The Center is blocked.
 - 1.2.2. The test block will not rest on top.
 - 1.2.3. The structure is outside of the stated size limitations.
- 1.3. Weight will be added to the test block until the structure fails.
- 1.4. The structure will be deemed to have "failed" once the bottom of the test block reaches 4" away from the base of the structure/testing platform
- 1.5. The structure will be evaluated by a strength-to-weight efficiency ratio. The total weight held in pounds will be divided by the total weight of the structure. The structure with the highest strength-to-weight ratio will be deemed the winner.

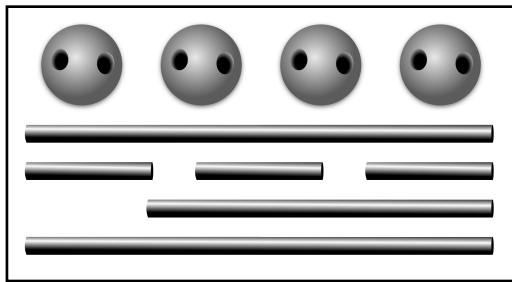

An example print bed with multiple members and joints printed on the same print job.

Note that all members and joints are individual items.



An example of one member and one joint.

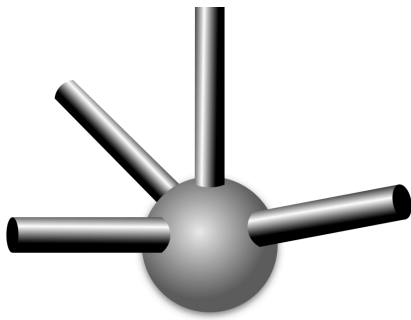

An example of one joint with 4 members coming into the joint from different directions.

All members are inserted into the joint without any glue or other adhesive, so the structure can be disassembled.

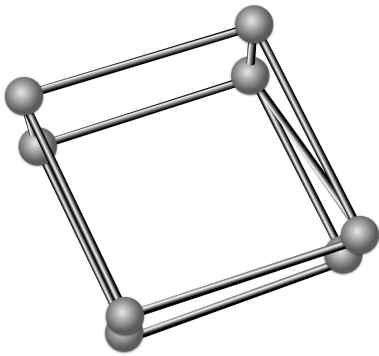

Example of completed structure with minimum of 8 joints.

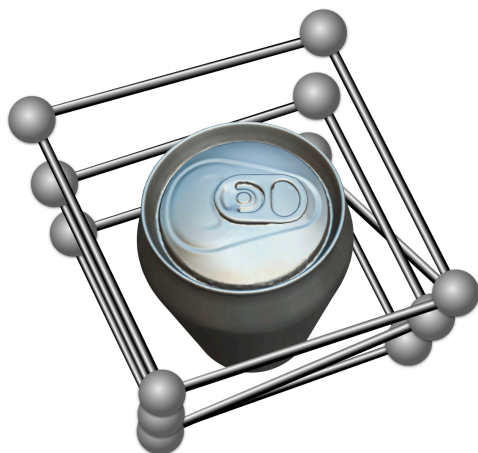

Example of completed structure with a regular 12-ounce soda can free standing in the structure. Note that the can could pass entirely through the structure from top to bottom.

FINAL EVENT - Additive Manufacturing Challenge

LEVEL: _____ Middle School _____ High School _____ Post Secondary

SCHOOL: _____

CAPTAIN: _____

Documentation Inspected (ie. Engineers Notebook or Portfolio) Yes: _____ No: _____

Evaluation Form

Criteria - Check Prior to Structure Assembly	Approved
No two single printed parts are preassembled.	_____
Students provided a design notebook that includes the STL file image(s) and drawings of each part.	_____
Video of the 3-D print is provided.	_____
Criteria - Check After Structure Assembly	
Weight: 30 grams maximum weight for the entire structure. WEIGHT - _____	_____
Flat top and flat bottom. Both top and bottom must be a rectangular shape with a minimum of 4" in length and width.	_____
Structure is taller than 4.5"	_____
Structure maximum dimensions are 6" deep x 6" wide x 5" height – meaning the entire structure must be able to be contained within these dimensions.	_____
Structure has 12 joints minimum, and each joint is no larger than 3/4" x 3/4" x 3/4".	_____
All members are detachable from all joints. No glues or other adhesives present.	_____
Structure is made from PLA, ABS, Nylon, or PETG, and no other material is present.	_____
A 12-ounce soda can fit inside the structure and can pass through the structure from top to bottom.	_____

Structure Strength-to-Weight Efficiency Ratio

Weigh Held _____ lbs. ÷ Weigh of Structure _____ g

Structure Efficiency = _____

Judge's Comments:

Judge's Signature: _____

Autonomous Vehicle Challenge (AVC)

Middle School, High School, Post-Secondary

Contest Description

For the Autonomous Vehicle Challenge each team will design and build a vehicle to navigate an obstacle course. A successful run is one where the vehicle navigates around the four (4) waypoints (blue stanchions) and crosses the finish line in under 5 minutes. Additionally, bonus points are given for completing special tasks during a run. Once earned, bonus points cannot be taken away. Teams can score bonus points even if they do not complete a successful run.

Rules and Course Layout

6. The course will be located on the parking lot of the Marion Veterans Memorial Coliseum, Marion, Ohio
7. Each vehicle must pass on the outside of stanchions in the course shown in Figure 1: AVC Course Layout. Blue stanchions will be placed on top of the blue corner dots shown, and yellow stanchions will be placed on the yellow dot. Final placements of stanchions and obstacles will be at the discretion of the judges.
8. The autonomous vehicle must fit inside a 24" x 24" x 24" space. Any robot entered that does not meet the size requirement by the end of the device evaluation or expands beyond that size during competition will be disqualified.
9. The vehicle must be fully autonomous and self-contained. No transmitters or communication beacons (other than GPS) of any kind are allowed. You may NOT tether to a laptop or other device. Everything necessary for the vehicle's navigation/processing/sensing must be attached and part of the vehicle itself.
10. Teams must bring documentation of their design process and the iterations that have taken place during the current school year. (ie. Engineers Notebook or Portfolio)
11. The AVC event will take place outside in the parking lot west of Veterans Memorial Coliseum. The event will run regardless of weather conditions. (with the exception of lightning)
12. Allowances for unforeseen delays will be taken into account but will be up to the contest judges. Please notify the contest judges immediately if you have an issue that prevents you from competing on schedule. (Repairs, bad code, gremlins, or dead batteries do not count. Be prepared for anything and everything.)
13. Each team is given 3 attempts throughout the day to earn points.
14. Teams will be called when it is time to bring your vehicle to the starting line and if you are not ready, you will forfeit that run and receive no points.
15. During the competition, the course will be closed to both spectators and participants. Participants with vehicles currently running may follow within the inner perimeter of the course (Yellow lines in Figure 1) but may not be on the course with the vehicles when they are running.
16. Teams are expected to make all necessary measurements, adjustments, and sensor readings before the event starts. Once the first heat is started, only competing vehicles and their team may be in the course, and to start their vehicle for the run.

17. We will be running one vehicle at a time. You will place your robot anywhere behind the start/finish line, wait for a signal, and press a button to start your robot. Time will begin when the robot first crosses the Start line. It must be in a ready position and be started with a physical input (button, switch, etc). It may not be started wirelessly.
18. If you need to wait for GPS lock or a setup routine, you will need to do this before your run starts.
19. Time-based points start at 300 and are deducted (1 per second) until the run is completed. You cannot get negative points for time. Time points only count if your run is successful. Each successful run will be given points based on the time it took them to finish the course and whatever bonuses were achieved.
20. All teams are scored and ranked by the total number of points accrued in all three runs. The team with the highest points wins. Each run will add more points to the team's overall score.

Bonus Points

- 50 - Passing through the arch
- 50 - Clearing the ramp
- 25 - Each successful corner cleared (vehicle must completely clear corner, not just reach it)

Scoring Examples:

- Teams complete a run in 2.5 minutes and passes under the hoop. this team would score 150 points for their time, 20 points for each completed corner (100 points), and 50 points for the hoop bonus. Their total score would be $150+100+50 = 300$
- The team does not complete the course but goes around three corners and clears the hoop and ramp. they would score no points for time (did not complete the course), but would receive 60 points for three successful corners, 50 points for the hoop, and 50 points for the ramp. they would end up with a total of 160 points for the run.
- Team completes course in one minute, but does not clear the ramp or the hoop. They would get 240 points for time and 100 points for successfully clearing all five corners. Their total score would be 340.

AVC Obstacle Details

On the course, you will encounter several obstacles. The dimensions and details for the obstacles can be found below.

Ramp

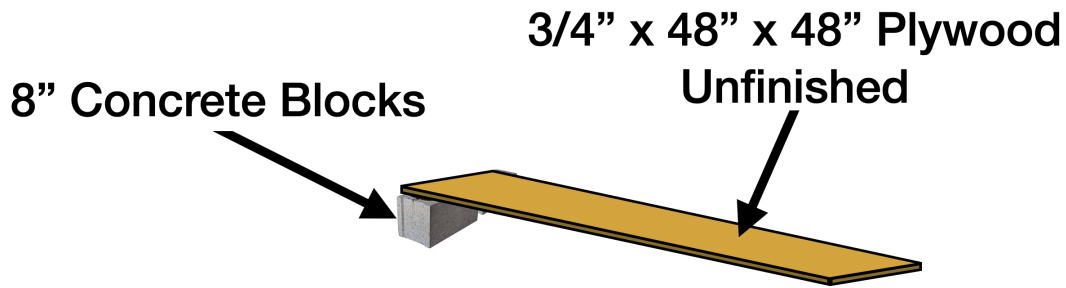

Stanchions



Arch

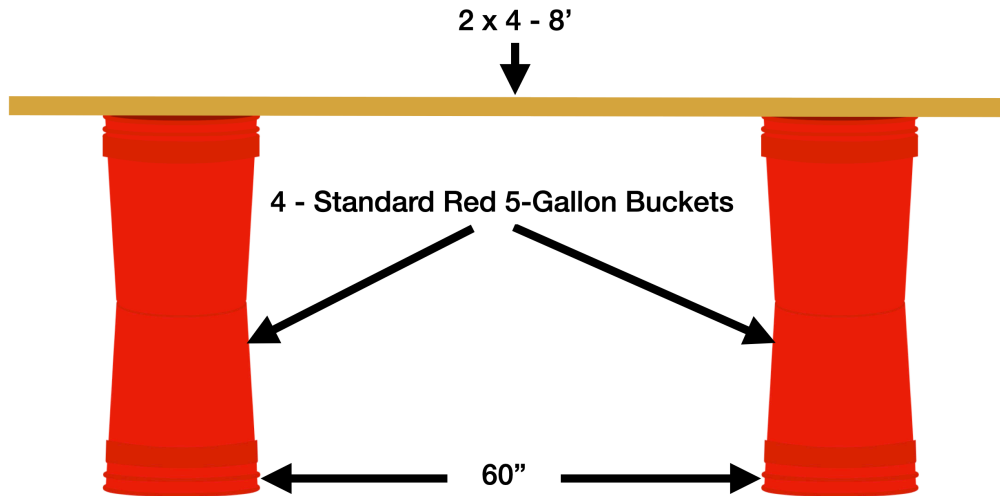

FINAL EVENT – Autonomous Vehicle Challenge (AVC)

LEVEL: _____ Middle School _____ High School _____ Post-Secondary

SCHOOL: _____

CAPTAIN: _____

Size Requirement Passed: _____ Robot Size Requirement: 24" x 24" x 24"

Documentation Inspected (ie. Engineers Notebook or Portfolio) Yes: _____ **No:** _____

	Points Each	Round 1	Points Awarded Round 1	Round 2	Points Awarded Round 2	Round 3	Points Awarded Round 3
Corner 1 Cleared	+20						
Corner 2 Cleared	+20						
Corner 3 Cleared	+20						
Corner 4 Cleared	+20						
Corner 5 Cleared	+20						
Ramp Cleared	+50						
Passed Through Arch	+50						
Course Complete < 5 min.	+300						
Total Points (Max. 500)							
Time Based Scoring Subtract one point for each second of the timed run. (if < 5 minutes)		Time in Seconds	-	Time in Seconds	-	Time in Seconds	-
Run Total (Total Points minus Time Based Scoring)							

Accrued Run Total: _____

Judge's Comments: _____

Judge's Signature: _____

Box Bot

Elementary, Middle School, High School

Contest Description

The Box Bot contest challenges student teams to design, construct, program and operate a battery-powered robot for use in a package delivery simulation.

Rules

1. Only two team members at a time are allowed at the playing field while the Robot is on a task attempt. To share in participation, members may switch out with each other between attempts.
2. There will be a random selection prior to the competition to determine which House the team is to deliver packages to.
3. Once the House is determined, the team steps up to the playing field and has 30 seconds to perform any needed setup routines and download the applicable program to their robot.
4. The Judge starts the match, and the team performs task attempts for 90 seconds. The first 70 seconds are autonomous (no remote control) and the final 20 seconds can be operator controlled via a wireless remote. More matches run until every team has competed once, this process is known as a "round". There are 3 rounds in the contest. After each match, teams may go to the pit and fix or adjust the robot.
5. The judges will signal when operator control is available. Teams may choose to continue with their robot in autonomous mode if desired.
6. The robot is defined as the micro-controller, (NXT, EV3, VEX-IQ, Parallax, Arduino, etc.) and anything connected to it in any way, including any loose objects being held, manipulated, or moved.
7. The robot must be programmed using programming software. (i.e. LEGO MINDSTORMS, RoboLab, Pbasic, C, etc.)
8. A scoring attempt is started when the team starts a program. Delaying or causing the release of stored energy in any form by hand is not allowed. This starting technique applies during the whole match, not just at the beginning.
9. Before the match, between scoring attempts, and only while the Robot is completely inside the "Endzone" area, the team may aim the Robot, repair it, add or remove parts, switch programs, and reset mechanisms.
10. All scoring attempts must start with the robot completely inside the "Base" area as shown in the robot position diagram in position A, with the robot turned on but all programs turned off. The robot must start from within the base lines. This starting technique applies during the whole match, not just at the beginning.

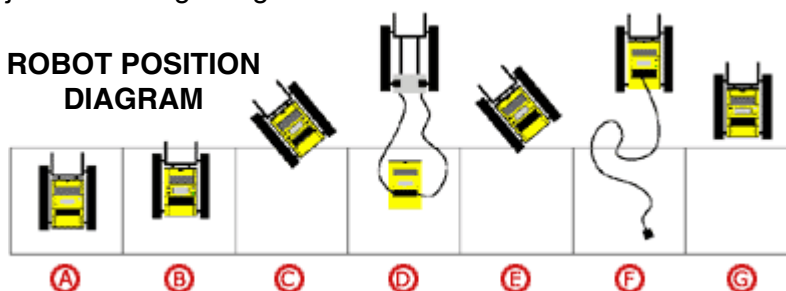

11. Jigs or other alignment devices may be used to help aim the robot in starting position and they must stay completely in the end zone.
12. While on a scoring attempt, the robot is to be controlled only by its program, its motors, and its interaction with the field, and not by interaction of any kind with the team. Remote control or signaling of sensors in any way is not allowed during the autonomous period.
13. A scoring attempt is an effort by the robot to move one or more of the game objects into a scoring position. Scoring attempts can be tried in any order, re-attempted whenever possible, or not attempted at all.
14. During the autonomous period the robot is understood to be on a scoring attempt starting from the instant a program is initiated. The next time the team controls or interacts with the robot in any way (touching/carrying is most common), it is a signal that the robot is failing or can no longer continue on its own, and the current scoring attempt is immediately terminated. The team must then bring the robot by hand to the starting position (Base) for the next scoring attempt. Any changes to the playing field after the instant the team interacts with the robot are invalid, and are reversed by the referee.
15. Points for scoring objects are awarded only if the object is **completely** in scoring position as specified in the game description, no matter where the robot is, and no matter whether the object is packaged, palletized, or bound/connected to other objects.
16. Objects in the way of future scoring attempts can be removed from the field by the referee upon request unless doing so would have a direct effect on scoring.
17. Refer to the robot position diagram after rule 10. If a scoring attempt is terminated while all functional parts of the Robot are completely out of the “**End Zone**” as shown in positions D, F and G, the team must bring the Robot by hand to Starting Position (Base) for the next scoring attempt. Because of this action, one “*Robot Return Penalty*” is deducted from the score, but accomplishments made during the scoring attempt are retained. Scoring attempts terminated in positions A, B, C and E do not result in a “*Robot Return Penalty*”, and there is no loss if the robot happens to be out of the Base when the match ends.
18. If an object being moved **IS NOT** held by or linked to the robot when a scoring attempt is terminated, the object stays where it is on the field. If an object **IS** held by or linked to the robot when a task attempt is terminated there are two possibilities: 1) Objects that began the Match in the End Zone are kept by the team for another task attempt. 2) Objects that did not begin the Match in the End Zone are taken off the playing field by the referee (and do not score).
19. Points can be scored in any order.
20. At any time during the match, the team may recover robot parts that come off as an obvious result of damage or disintegration. The team may do this by hand or request help from the referee.
21. The team may not touch “Task Models” or “Scoring Objects” at any time. If they are damaged or otherwise disturbed between task attempts or by anything but valid robot action, the referee restores them as soon as possible. If it is obvious to the referee that task model damage is part of team strategy the team will be disqualified from the event.

22. To minimize controversy about what happened during a match, THE SCORE IS DETERMINED AT THE END OF THE MATCH, BY THE CONDITION OF THE FIELD AT THAT TIME ONLY. If the thickness of a line on the field comes into question, and for other situations that are “too close to call” the team is given the benefit of the doubt. Scores from each Round are independent, and only a team’s best score counts.
23. The “Terms & Rules” are superseded by the “Game Description” when the two conflict.
24. Teams must bring documentation of their design process and the iterations that have taken place during the current school year. (ie. Engineers Notebook or Portfolio)
25. Decisions of the judges are final and binding.

Game Description

Points are awarded for moving packages (foam blocks) into a scoring area (staging, truck or house).

Points:

- 5 points for each box in the “staging” position. Staging position is shown in yellow on the playing field. The warehouse is the green area on the playing field diagram.
 - 10 points for each box in the “truck” position. The truck position is shown in blue on the playing field. There will be walls on each side of the truck and boxes must be inside the truck walls and not touching a black line to count.
 - 15 points for each box stacked on another box in the “truck” position. The truck position is shown in blue on the playing field. There will be walls on each side of the truck and boxes must be completely inside black line and not sitting on a field or truck wall to count.
 - 10 points for each box in the appropriate “house”. The light blue areas are the 2 house positions one of which will be randomly selected as a delivery location prior to the start of the match. Boxes must be inside the truck walls and not touching a black line to count
 - 20 points for each box stacked on another box in the “house” position. Boxes must be completely inside black lines and not touching field surface or truck wall to count.
 - -10 points for any damage or movement of the “truck” by the robot or package making contact with the truck. This would include knocking down the truck walls or unintentional movement of the truck walls.
 - -5 points anytime a robots task is interacted with outside of the “base” (Robot Return Penalty)
1. “Starting Position” is with the entire robot completely within the “Base”. The base is shown in red on the playing field diagram and is defined as the square center section on one end of the board. (No part of the robot may extend over the black lines surrounding the base)
 2. On the judges signal, the robot is to leave the base, attempt to earn challenge points through a scoring attempt and return to base with only its program to control it. If the team touches the robot before it returns to the end zone a “Robot Return Penalty” will be given and the robot must be returned to “Starting Position.”

Tips:

- Concentrate on developing a solution step by step. Don’t try to get it all at once or things will get out of hand very quickly.
- Teamwork is crucial. The challenge is too much for one person to get done alone in time. Try dividing up tasks for different team members.
- Test and refine your design as many times as possible. The robot must be ready for whatever comes its way.

Playing Field

The following is the description for the Box Bot competition for the National Robotics Challenge. Please keep in mind that the challenge points do not necessarily need to be earned in a specific order.

Boxes

The 4" x 4" x 4" foam blocks shown are what will be used for the scoring objects (boxes) in the competition. These are trampoline/parkour foam blocks. The blocks can be purchased on Amazon: <https://www.amazon.com/dp/B0C4SLC597>

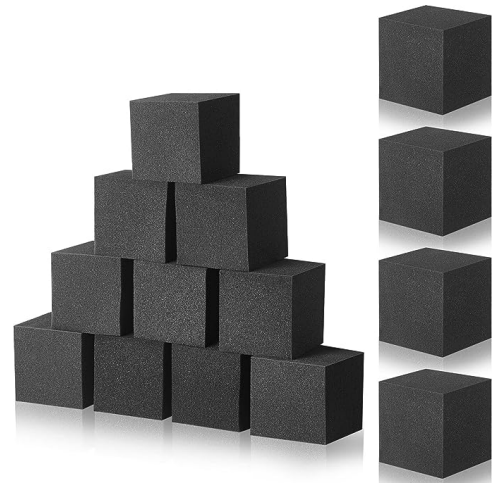

4" X 4" FOAM BLOCKS (BOXES)

Truck

Truck walls will be 1" x 6" x 6" blocks. These blocks can be made from wood or plastic (3D printed). Walls will be held in place with VEX 1 x 2 Connector pins. 4.8mm diameter x 14mm deep with a 6.6mm diameter x 2mm deep counterbore holes will be drilled into each truck wall allowing the 1x2 connector pin to hold the wall in place. NOTE: The wall can be knocked over if the robot makes contact with the wall. Teams should make sure their robots will not hit the wall as it passes or while loading the truck. Points are deducted if a wall falls over from robot action.

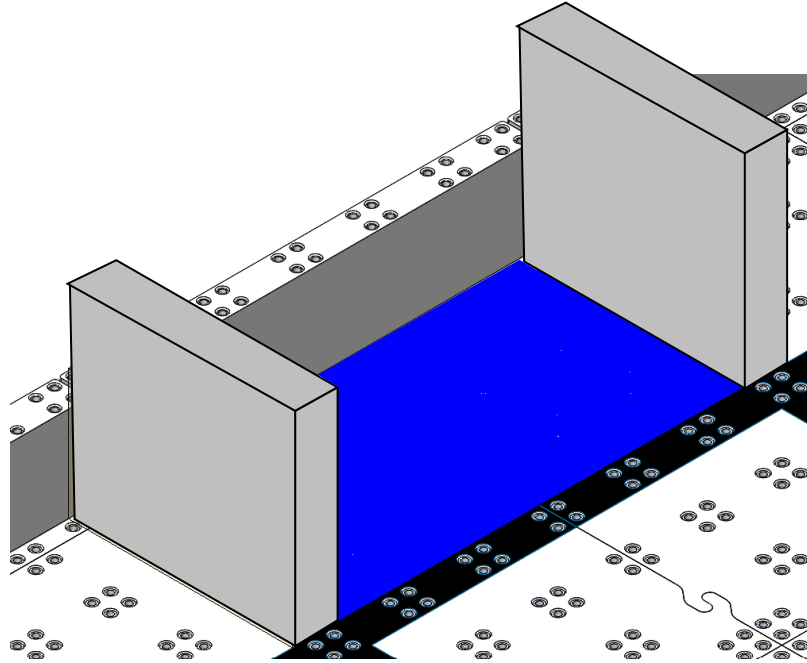

Playing Field

For the main playing field the NRC is created from 2 - Vex IQ Field Kits (Half 4'x8' Field) to create a full 4' x 8' field. You can purchase this product at: www.vexrobotics.com

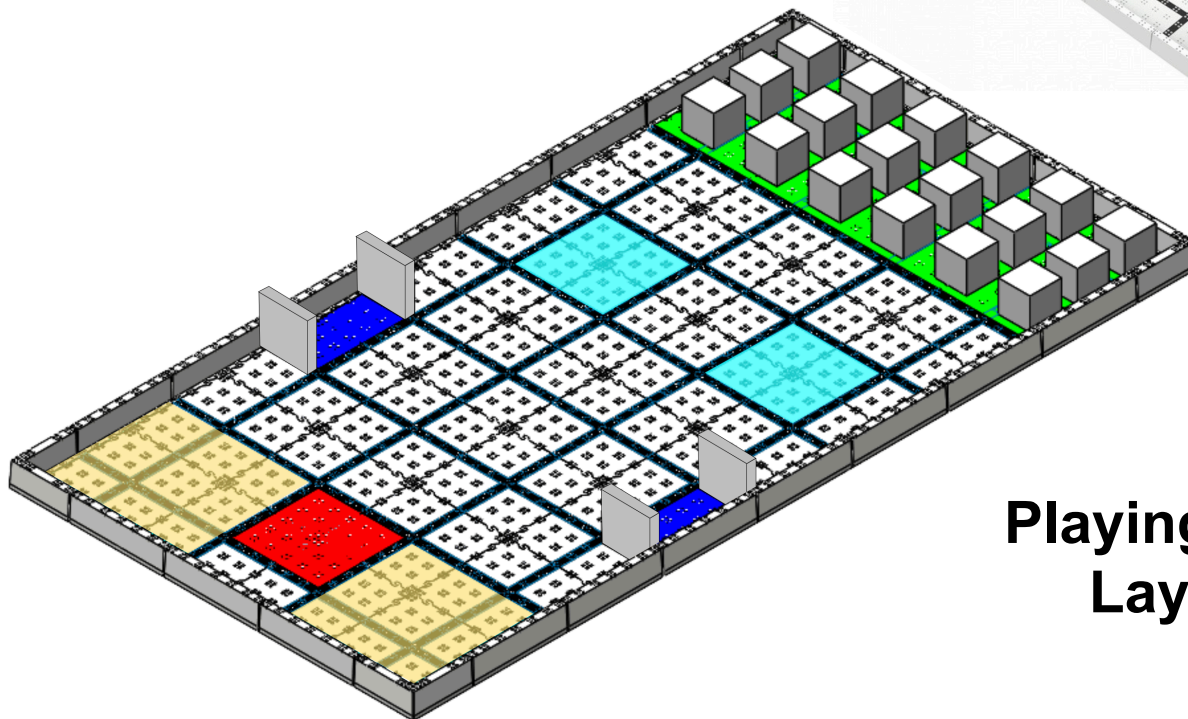
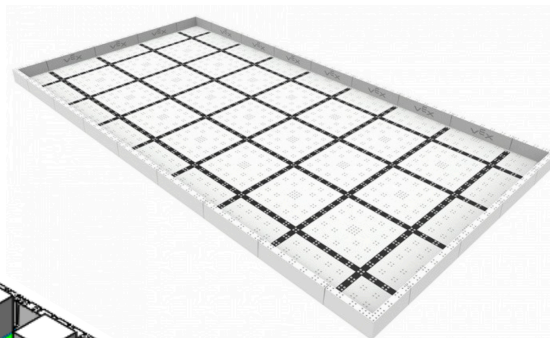

Playing Field Layout

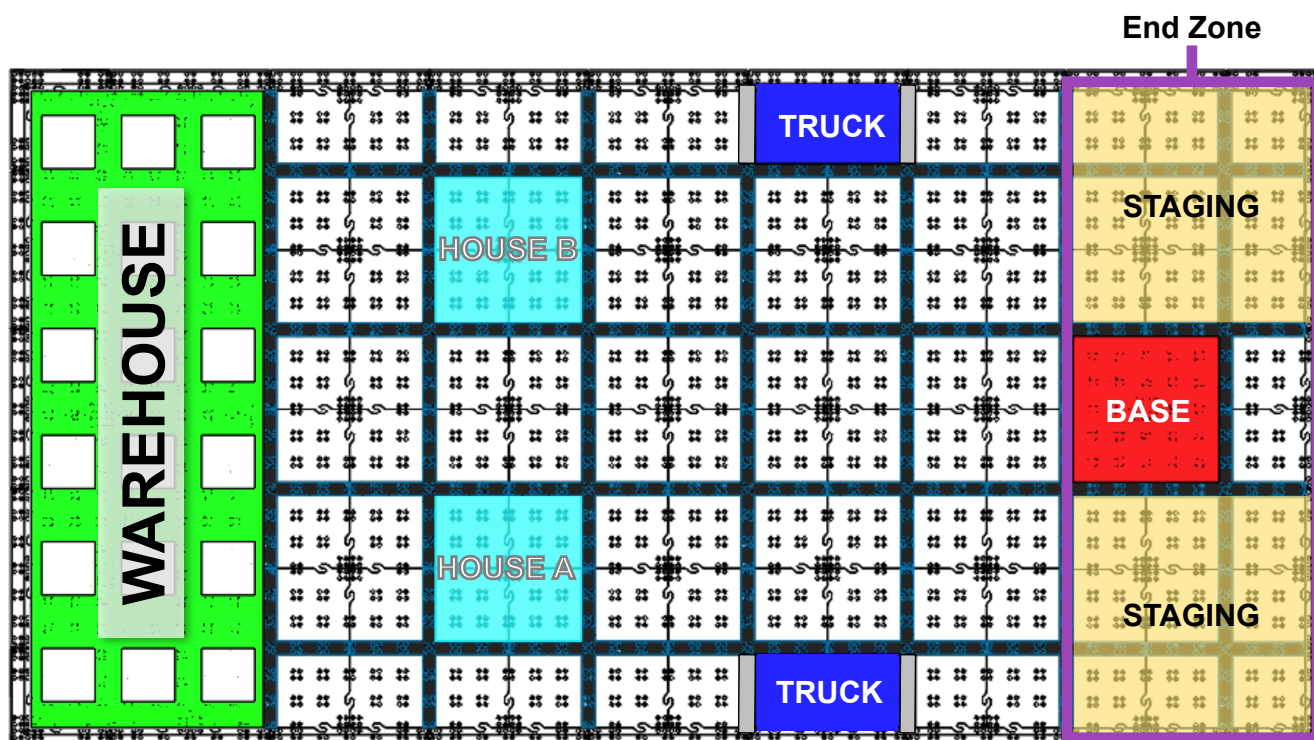

FINAL EVENT – Box Bot

LEVEL: _____ Elementary _____ Middle School _____ High School

SCHOOL: _____

CAPTAIN: _____

Documentation Inspected (ie. Engineers Notebook or Portfolio) Yes: _____ No: _____

Team Check-In _____		Table/House _____		Table/House _____		Table/House _____	
Tasks	Points Each	Scored Objects Round 1	Points Awarded Round 1	Scored Objects Round 2	Points Awarded Round 2	Scored Objects Round 3	Points Awarded Round 3
<i>In Staging (Position 1)</i>							
• Box	+5						
<i>Truck (Position 2)</i>							
• Box on Ground Level	+10						
• Stacked Box	+15						
<i>House (Position 3)</i>							
• Box on Ground Level	+10						
• Stacked Box	+20						
<i>Damage</i>							
• Damage to Truck (Position 2)	-10						
<i>Robot Return Penalty</i>							
Number of times the robot is handled by a team member outside the End Zone.	-5						
Total Points							

Highest Total: _____

Judge's Comments: _____

Judge's Signature: _____

Combat Robot

UPDATED FOR 2026

Classes: Antweight-Plastic, Beetleweight
Middle School, High School, Post-Secondary (Beetleweight ONLY)

Contest Description

In the Robot Combat event students design and create a single custom-built machine that employs one or more methods of destroying or disabling their robot competitor. This robotic device will be remote-controlled but may include some autonomous operations. We are utilizing a modified version of the SPARC Robot Construction Specifications v1.5.

Rules

- 0. Size Requirements:** The Robot must fit inside a 14" x 14" x 14" space. Any robot entered that does not meet the size requirement by the end of the device evaluation or expands beyond that size during competition will be disqualified.
1. Overview and Purpose
 - 1.1. The SPARC Robot Construction Specifications was created to provide both builders and event organizers with an up to date and easy to implement ruleset.
 - 1.2. The SPARC Standard Ruleset will call out areas where the rules are often altered by the events and will provide the most frequently used options for easy adaptation.
 - 1.3. If you choose to utilize the SPARC Robot Construction Specifications and modify the rules to adapt to your event please note specific areas that differ from the standard SPARC rules in section
2. Deviations From Robot Construction Specifications
 - 2.1. The Combat Robot rules are a modified version of the SPARC Robot Construction Specifications v1.5. To simplify the understanding for the specifications some section of the original ruleset were completely removed. To view the original rules go to: www.sparc.tools
3. General
 - 3.1. All participants build and operate robots at their own risk. Combat robotics is inherently dangerous. There is no amount of regulation that can encompass all the dangers involved. Please take care not to hurt yourself or others when building, testing, and competing.
 - 3.2. If you have a robot or weapon design that does not fit within the categories set forth in these rules or is in some way ambiguous or borderline, please contact the event organizer. Safe innovation is always encouraged, but surprising the event staff with your brilliant exploitation of a loophole may cause your robot to be disqualified before it ever competes.
 - 3.3. Each event has safety inspections. It is at their sole discretion that your robot is allowed to compete. As a builder you are obligated to disclose all operating principles and potential dangers to the inspection staff.
 - 3.4. Cardinal Safety Rules: Failure to comply with any of the following rules could result in expulsion or worse, injury and death.
 - 3.4.1. Radios that do not operate using spread spectrum technology may not be turned on at or near events for any purpose without obtaining the appropriate frequency clip or explicit permission from the event.
 - 3.4.2. Proper activation and deactivation of robots is critical. Robots must only be activated in the arena, testing areas, or with expressed consent of the event and it's safety officials.
 - 3.4.3. All robots must be able to be FULLY deactivated, which includes power to drive and weaponry, **in under 60 seconds by a manual disconnect.**

- 3.4.4. All robots not in an arena or official testing area must be raised or blocked up in a manner so that their wheels or legs cannot cause movement if the robot were turned on. Runaway bots are VERY dangerous.
- 3.4.5. Locking devices: Moving weapons that can cause damage or injury must have a **clearly visible** locking device in place **at all times** when not in the arena. Locking devices must be clearly identified. Examples of acceptable options include neon paint, brightly colored tabs, and remove before flight tags. Locking devices must be clearly capable of stopping, arresting or otherwise preventing harmful motion of the weapon. Locking devices must securely affix in place on the robot such that they cannot easily come loose or fall off without intent.
- 3.4.6. Weapon locking pins **must be in place** when weapon power is applied during a robot's power-on procedure. This includes **all** powered weapons regardless of the power source or weight class.
- 3.4.7. It is expected that all builders will follow basic safety practices during work on the robot at your pit station. Please be alert and aware of your pit neighbors and people passing by.

4. Weight Classes. This event offers the following weight classes: Beetleweight and Antweight-Plastic

4.1. Locomotion Weight Bonuses

- 4.1.1. Shufflers receive a 1.25x weight bonus
- 4.1.2. Non-Traditional receive a 1.5x weight bonus
- 4.1.3. Walkers receive a 2x weight bonus. Rolling Shufflers Non-Traditional Walker

Rolling	Shufflers	Non-Traditional	Walker
1lb / 454g	1.25 lb	1.5 lb	2 lb
3lb / 1.36kg	3.75 lb	4.5 lb	6 lb

5. Plastic Classes (**Antweight ONLY**). The spirit of these classes is to have an easy entry point for new builders and to encourage creative designs by limiting materials to plastics that are easy to work with, commonly used in 3D printers, and don't have strength characteristics common in the standard classes. Components used for structure, armor, and weapons must be 3D printed.

- 5.1. PET, PETG, ABS, PLA, PLA+, and ASA are the only materials that can be used for the chassis and weapons. No other types of plastics or materials allowed (ie. metal, carbon fiber, UHMW, etc). Materials that are functionally identical to PLA+ but have a different name for marketing purposes will be considered PLA+ when determining legality.
- 5.2. Composite and blended materials that use legal materials as a base are not permitted. Examples include but are not limited to: Carbon Fiber PLA, Glass Filled ABS, and Flex PLA.
- 5.3. Non-plastic parts such as motors, electronics, axles, fasteners and adhesives can be any material, but cannot be used in such a way to enhance the structural integrity, armor the robot, or enhance any weapon. Magnets to enhance traction or downforce are prohibited. Foam and rubber or rubber-like materials, including silicone, urethane, and TPU, are allowed for wheels and padding of electronics, provided they meet the requirements of this section. Additionally, custom cast wheels are permitted, provided they meet the requirements of this section.
- 5.4. While painting robots is permitted, excessive coatings are subject to event organizer review and approval.
- 5.5. Robots may be disqualified at the Event Organizer's discretion if it is deemed to violate the spirit of the class. Contact the event organizer ahead of time if you are not sure your robot meets the above definition.

6. Mobility

- 6.1. All robots must have **easily visible and controlled mobility** in order to compete. Methods of mobility include but are not limited to:
 - 6.1.1. Rolling (wheels, tracks or the whole robot)
 - 6.1.2. Walking: Walking robots have **no** rolling elements in contact with the floor and **no** continuous rolling or cam operated motion in contact with the floor, either directly or via a linkage. Motion is "continuous" if continuous operation of the drive motor(s) produces

continuous motion of the robot. Linear-actuated legs and novel non-wheeled drive systems may qualify for this bonus. If you are intending to enter a non-wheeled robot in any event contact the event as soon as possible to determine what if any weight bonus you will qualify for.

6.1.3. Shuffling (rotational cam operated legs)

6.1.4. Non-Traditional

6.1.4.1. Bristle/Torque Drive: Vibration or torque reaction of a powered system to generate motion

6.1.4.2. Gyro Walker: Gyroscopic forces used in conjunction with a rotating arm that tilts a portion of the robot to generate motion

6.1.4.3. Ground effect air cushions (hovercrafts)

6.1.4.4. Jumping and hopping may be allowed at some events, contact the event organizer if you're intending on using this as a method of locomotion.

6.1.4.5. Flying (airfoil using, helium balloons, ornithopters, etc.) may be allowed at some events, contact the event organizer if you're intending on using this as a method of locomotion.

7. Robot control requirements:

7.1. Tele-operated robots must be radio controlled, or use an approved custom system as described in 6.4.3. Radio controlled robots must use approved ground frequencies, typically 27 / 49 / 50 / 53 / 75 / 900 / 2400 for the United States.

7.2. Tethered control is not allowed.

7.3. Pre 1991 non-narrow band radio systems are not allowed.

7.4. Radio system restrictions for this event with corresponding weight and or weapon restrictions:

7.4.1. Radio systems that stop all motion in the robot (drive and weapons), when the transmitter loses power or signal, are required for all robots with active weapons or any robot over 12lbs. This may be inherent in the robots electrical system or be part of programmed fail-safes in the radio. Robots 1 lb and less typically will be required to have drive fail-safes.

7.4.2. All robot radio systems must have a way to change frequencies or coded channels to prevent radio conflicts. Having at least **two** frequencies or coded channels available is **required**. Lack of extra frequencies may result in a forfeit. Digital spread-spectrum radios that use frequency hopping or automatic channel selection qualify under this rule.

7.4.3. If you are using a home built control system, or a control system not covered here, you must first clear it with the event you plan to attend.

7.4.4. Toy radio systems are sometimes allowed at events for robots up to 12 lbs with no active weapons.

7.4.5. RC systems on the AM band are sometimes allowed at events for robots up to 12 lbs with no active weapons. 6.4.6. All robots that are either: a.) 30 lbs or above or b.) 12 lbs or above with an active weapon **MUST** use a radio systems on the FM band with PCM, IPD coding, a digitally coded 900 MHz or 2.4GHz system (for example IFI, Spektrum, etc.), or an approved custom control system.

7.4.6. This event does not require a separate power switch for the radio.

7.4.7. Most events do not provide reserved frequencies/channels for testing and safety.

8. Autonomous/Semi-Autonomous Robots: Any robot that moves, seeks a target, or activates weapons without human control is considered autonomous. If your robot is autonomous you are required to contact this event before registration.

8.1. Autonomous robots must have a clearly visible light for each autonomous subsystem that indicates whether or not it is in autonomous mode, e.g. if your robot has two autonomous weapons it should have two "autonomous mode" lights (this is separate from any power or radio indicator lights used).

8.2. Robots in the 12 pound or under classes are exempt from the remaining rules below, but safe operation, arming, and disarming must be demonstrated in safety inspections.

8.3. The autonomous functionality of a robot must have the capability of being remotely armed and disarmed. (This does not include internal sensors, drive gyros, or closed loop motor controls.)

8.3.1. While disarmed, all autonomous functions must be disabled.

- 8.3.2. When activated the robot must have no autonomous functions enabled, and all autonomous functions must fail-safe to off if there is loss of power or radio signal.
- 8.3.3. In case of damage to components that remotely disarm the robot, the robot's autonomous functions are required to automatically disarm **within one minute of the match length time** after being armed.

9. Batteries and Power

- 9.1. The only permitted batteries are ones that cannot spill or spray any of their contents when damaged or inverted. This means that standard automotive and motorcycle wet cell batteries are prohibited. Examples of batteries that are permitted: gel cells, Hawkers, NiCads, NiMH, dry cells, AGM, Llon, LiFe, LiPoly, etc. If your design uses a new type of battery, or one you are not sure about please contact the event you're planning to attend.
- 9.2. All onboard voltages above **48 Volts** require prior approval from this event. (It is understood that a charged battery's initial voltage state is above their nominal rated value)
- 9.3. All electrical power to weapons and drive systems (systems that could cause potential human bodily injury) must have a manual disconnect that can be activated within **15 seconds** without endangering the person turning it off. (E.g. No body parts in the way of weapons or pinch points.) Shut down must include a **manually** operated mechanical method of disconnecting the main battery power, such as a switch (Hella, Whyachi, etc) or removable link. Relays may be used to control power, but there must also be a mechanical disconnect. Please note that complete shut down time is specified in section 3.4.3.
- 9.4. All efforts must be made to protect battery terminals from a direct short and causing a battery fire.
- 9.5. If your robot uses a grounded chassis you must have a switch capable of disconnecting this ground. ICE robots are excepted from this rule if there is no practical way to isolate their grounding components. You must contact this event for this exception.
- 9.6. All Robots must have a light easily visible from the outside of the robot that shows its main power is activated.

10. Pneumatics

- 10.1. Pneumatic systems on board the robot must only employ non-flammable, nonreactive gases (CO₂, Nitrogen and air are most common). It is not permissible to use fiber wound pressure vessels with liquefied gasses like CO₂ due to extreme temperature cycling.
- 10.2. You must have a safe and secure method of refilling your pneumatic system.
 - 10.2.1. SPARC recommends the use of standard paintball fill fittings available at many retail outlets and online. For specs see Part#12MPS from Foster, <http://www.couplers.com>.
- 10.3. Exemptions**
 - 10.3.1. Robots **12 lbs and under** and systems with gas storage of **2 fl oz or less** are exempt from the remaining rules in this section **provided that** the maximum actuation pressure is **250 PSI or less** and all components are used within the specifications provided by the manufacturer or supplier. If the specifications aren't available or reliable, then it will be up to the EO to decide if the component is being used in a sufficiently safe manner.
- 10.4. All pneumatic components on board a robot must be securely mounted. Particular attention must be made to pressure vessel mounting and armor to ensure that if ruptured, it will not escape the robot. (The terms 'pressure vessel, bottle, and source tank' are used interchangeably)
- 10.5. All pneumatic components within the robot must be rated or certified for AT LEAST the maximum pressure in that part of the system. You may be required to show rating or certification documentation on ANY component in your system.
- 10.6. All pressure vessels must be rated for at least 120% of the pressure they are used at and have a current hydro test date. (This is to give them a margin of safety if damaged during a fight.) If large actuators, lines, or other components are used at pressures above 250psi, these will also need to be over-rated and are to be pre-approved for this event.
- 10.7. All primary pressure vessels must have an overpressure device (burst/rupture disk or overpressure 'pop off') set to no more than 130% of that pressure vessel's rating. (Most commercially available bottles come with the correct burst assemblies, use of these is encouraged)

- 10.8. If regulators or compressors are used anywhere in the pneumatic system there must be an (additional) over pressure device downstream of the regulator or compressor set for no more than 130% of the lowest rated component in that part of the pneumatic system.
 - 10.9. All pneumatic systems must have a manual main shut off valve to isolate the rest of the system from the source tank. This valve must be easily accessed for robot de activation and refilling.
 - 10.10. All pneumatic systems must have a manual bleed valve downstream of the main shut off valve to depressurize the system. This bleed valve must be easily accessed for deactivation. This valve must be left OPEN whenever the robot is not in the arena to ensure the system cannot operate accidentally.
 - 10.10.1. It is required to be able to easily bleed all pressure in the robot before exiting the arena. (You may be required to bleed the entire system if it is believed that you have any damaged components.)
 - 10.11. All regulated pneumatic systems must have an appropriate gauge scaled for maximum resolution of the pressure on the low-pressure side of the system. HPA (air, nitrogen, or inert gas) systems must have gauges on both the high AND low pressure sides of regulators. A gauge or other clear visual indication that the system is charged is strongly recommended for all pneumatic systems. Whether specifically required or not.
 - 10.12. If back check valves are used anywhere in the system you must ensure that any part of the system they isolate can be bled and has an over pressure device.
 - 10.13. Any pneumatic system that does not use a regulator, or employs heaters or pressure boosters, or pressures above 2500psi must be pre-qualified by the event you're planning to attend.
11. Hydraulics
- 11.1. Robots in the 12 lb class or lighter are exempt from the remaining rules in this section, but good engineering and best practices must be used in all hydraulic systems. However, the pressure for 12-pound or less robots is limited to 250psi, and there must be an easy way to determine this pressure. Contact the event with any questions.
 - 11.2. All hydraulic components onboard a robot must be securely mounted. Particular attention must be made to pump and accumulator mounting and armor to ensure that if ruptured, direct fluid streams will not escape the robot.
 - 11.3. All hydraulic components within the robot must be rated or certified for AT LEAST the maximum pressure in that part of the system. You may be required to show rating or certification documentation on ANY component in your system.
 - 11.4. Any accumulators or large reservoirs must be rated for at least 120% of the pressure at which they are used. (This is to give them a margin of safety if damaged during a fight)
 - 11.5. All hydraulic systems must have an overpressure bypass device set to no more than 130% of the lowest component rating. It must be rated to bypass the full volume of the hydraulic pump.
 - 11.6. All hydraulic systems must have a(n) accessible manual bypass valve(s) to easily render the system harmless.
 - 11.7. All hydraulic systems must have appropriate gauges scaled for maximum resolution of the pressures in that part of the system.
 - 11.8. All hydraulic systems must use non-flammable, non-corrosive fluid and must be designed not to leak when inverted.
 - 11.9. Any hydraulic system using pressure boosters, or pressures above 5000psi (without accumulator) or pressures above 2000psi (with accumulator) must be pre qualified by the event.
 - 11.10. Please note that some simple low pressure and volume hydraulic systems, like simple braking, may not need to adhere to all the rules above. You are required to contact the event if you would like an exception.
12. Internal Combustion Engines (ICE) and liquid fuels are not allowed.
13. Rotational weapons:
- 13.1. Spinning weapons that can contact the arena walls above 5 inches from the arena floor during normal operation are not permitted. (Spinning weapons that can contact the arena walls below 5 inches are allowed)

- 13.2. Spinning weapons must come to a full stop within 60 seconds of the power being removed using a self-contained braking system.
14. Springs and flywheels
 - 14.1. Springs used in robots in the 12 lbs class or smaller and those loaded simply by the weight of the robot (e.g., suspension systems) are excepted from the rules in this section. However, safe operation and good engineering are always required.
 - 14.2. Any large springs used for drive or weapon power must have a way of loading and actuating the spring remotely under the robot's power.
 - 14.2.1. Under no circumstances must a large spring be loaded when the robot is out of the arena or testing area.
 - 14.2.2. Small springs like those used within switches or other small internal operations are excepted from this rule.
 - 14.3. Any flywheel or similar kinetic energy storing device must not be spinning or storing energy in any way unless inside the arena or testing area.
 - 14.3.1. There must be a way of generating and dissipating the energy from the device remotely under the robot's power.
 - 14.4. All springs, flywheels, and similar kinetic energy-storing devices must fail to a safe position upon loss of radio contact or power.
 15. Forbidden Weapons and Materials. The following weapons and materials are absolutely forbidden from use:
 - 15.1. Weapons designed to cause invisible damage to the other robot. This includes but is not limited to:
 - 15.1.1. Electrical weapons
 - 15.1.2. RF jamming equipment, etc.
 - 15.1.3. RF noise generated by an IC engine. (Please use shielding around sparking components)
 - 15.1.4. EMF fields from permanent or electro-magnets that affect another robot's electronics.
 - 15.1.5. Entangling Weapons or defenses: these are weapons or defenses that can reasonably be expected to stop drive train and/or weapon motion by being wrapped around rotating parts. This includes nets, tapes, strings, and other entangling materials or devices.
 - 15.1.6. Weapons or defenses that that can reasonably be expected to stop combat completely of both (or more) robots.
 - 15.2. Weapons that require significant cleanup, or in some way damages the arena to require repair for further matches. This includes but is not limited to:
 - 15.2.1. Liquid weapons. Additionally a bot may not have liquid that can spill out when the robot is superficially damaged.
 - 15.2.2. Foams and liquefied gasses
 - 15.2.3. Powders, sand, ball bearings and other dry chaff weapons
 - 15.3. Un-tethered Projectiles (see tethered projectile description in Special Weapons section 15.1)
 - 15.4. Heat and fire are forbidden as weapons. This includes, but is not limited to the following:
 - 15.4.1. Heat or fire weapons not specifically allowed in the Special Weapons section (15.2)
 - 15.4.2. Flammable liquids or gases
 - 15.4.3. Explosives or flammable solids such as:
 - 15.4.3.1. DOT Class C Devices
 - 15.4.3.2. Gunpowder / Cartridge Primers
 - 15.4.3.3. Military Explosives, etc.
 - 15.5. Light and smoke based weapons that impair the viewing of robots by an Entrant, Judge, Official or Viewer. (You are allowed to physically engulf your opponent with your robot however.) This includes, but is not limited to the following:
 - 15.5.1. Smoke weapons not specifically allowed in the Special Weapons section (15.3)
 - 15.5.2. Lights such as external lasers above 'class I' and bright strobe lights which may blind the opponent.
 - 15.6. Hazardous or dangerous materials are forbidden from use anywhere on a robot where they may contact humans, or by way of the robot being damaged (within reason) contact humans. Contact the event you plan to attend if you have a question.

16. Special weapon descriptions allowed at this event:
 - 16.1. Tethered Projectiles are not allowed at this event.
 - 16.2. Heat and Fire are not allowed at this event.
 - 16.3. Smoke Effects are not allowed at this event.
17. **(New for 2026)** Robot designs can not be modified or changed from the configuration that is checked in at the beginning of the competition. If a robot part is damaged during combat, it may be repaired, but can only be replaced with an identical part.
18. **Surrender Rule**
 - 18.1. Each team will have a towel that can be thrown onto the Combat Arena to forfeit a match. This can be done at anytime once the judges have started the match.
19. Teams must bring documentation of their design process and the iterations that have taken place during the current school year. (ie. Engineers Notebook or Portfolio)
20. **Decisions of the judges are final and binding.**

Combat Arena - The field measures 8' square with a 24" interior height on a steel, concrete or plywood floor. The frame of the enclosure is made from 80/20 with clear Lexan panels for added safety and easy viewing. The floor may include trap doors that can be activated during the match. Other hazards may also be included.

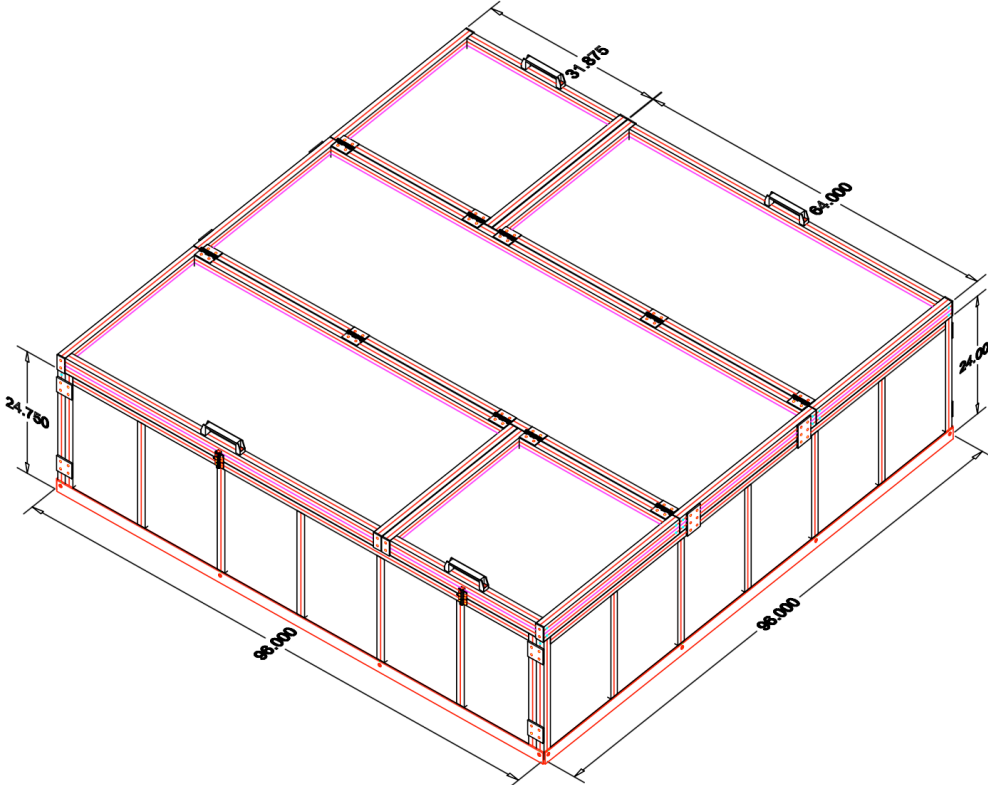

FINAL EVENT - Combat Robot

LEVEL: _____ Middle School _____ High School _____ Post Secondary

WEIGHT CLASS: _____ Antweight -Plastic (1#) _____ Beetleweight (3#)

SCHOOL: _____

CAPTAIN: _____

Size Requirement Passed: _____ Robot Size Requirement: 14" x 14" x 14"

Weight Requirement Passed: _____

Robot Safe to Compete: _____

Documentation Inspected (ie. Engineers Notebook or Portfolio) Yes: _____ No: _____

Evaluation Form

Criteria	Approved
Spinning weapons come to a full stop within 60 seconds of the power being removed using a self-contained braking system.	_____
Spinning weapons can not contact wall above 5 inches.	_____
All springs, flywheels, and similar kinetic energy storing devices fail to a safe position on loss of radio contact or power.	_____
Moving weapons that can cause damage or injury have a clearly visible locking device. Locking devices are painted in neon orange or another high-visibility color. Locking devices are clearly capable to stopping, arresting or otherwise preventing motion of the weapon.	_____
Weapon locking pins in place for robot's power-on procedure.	_____
Robot can be FULLY deactivated, which includes power to drive and weaponry, in under 60 seconds by a manual disconnect .	_____
Electrical power to weapons and drive systems (systems that could cause potential human bodily injury) has a manual disconnect that can be activated within 15 seconds without endangering the person turning it off. (E.g. No body parts in the way of weapons or pinch points.)	_____
Radio system stops all motion in the robot (drive and weapons), when transmitter loses power or signal.	_____
Onboard voltages is less than 48 Volts	_____
Pneumatics and/or Hydraulics meets requirements (if applicable)	_____
Time for Seeding Task Test	_____

Judge's Comments:

Judge's Signature: _____

Manufacturing Workcell

Elementary, Middle School, High School, Post-Secondary

Contest Description

In the Manufacturing Workcell contest, the participants design, construct, and operate a system that performs one or more manufacturing processes. The manufacturing workcell may include operations that demonstrate both fundamental and/or advanced applications.

Rules

Each manufacturing workcell shall include:

1. Mechanical devices such as transfer and clamping devices.
2. Electronic controlling device(s) such as computers or PLCs.
3. Each manufacturing workcell must fit within an 8' x 8' footprint. Each school is permitted to enter a maximum of four workcells.
4. The team will be allocated ten (10) minutes to demonstrate the operation of the workcell and ten (10) minutes for a discussion with the judging team.
5. All items manufactured by students must be marked with a red dot.
6. The following will be provided if the Director of Events is notified two weeks before the date of the competition.
 - One 110-volt standard outlet, 20 AMP, single phase, 60-cycle quad box ONLY
 - One 100 - PSI compressed air hose, ¼" male quick disconnect ONLY
7. **If air is required, the school must supply their own air filter for their entry.**
8. Teams must bring documentation of their design process and the iterations that have taken place during the current school year. (i.e., Engineers Notebook or Portfolio)
9. Decisions of the judges are final and binding.

FINAL EVENT - Manufacturing Workcell

Rubric and Evaluation Criteria

Rubric and Evaluation Criteria for Standards-Based Robotics Competitions & Related Learning Experiences					
Evaluation Criteria	Expert = 4	Proficient = 3	Emergent = 2	Novice = 1	Comments
Design & Process Criteria					
Creating Viable Solutions to a Variety of Human Wants, Needs, and Challenges.	Multiple, well developed solutions exist meeting all critical criteria.	Multiple solutions are evident & one is developed meeting majority of criteria.	Multiple, undeveloped solutions are evident.	A solution that may or may not be developed is evident.	
Simple and Complex Systems	All simple & complex systems are identified & function efficiently.	Functioning simple and complex systems exist.	Multiple simple systems exist that may function.	One functioning simple system exists.	
Design Process (scientific method, technological problem solving process, etc.)	Formal design process utilized, documented & enhances efficiency.	Formal design process utilized and fully documented.	Formal design process utilized consistently.	Some evidence that formal design process was utilized.	
Utilization of Resources: Tools/Machines, Materials, Information, People, Capital, Energy, & Time)	Resources used within constraints, efficiency maximized, environmental harm minimized.	Resources utilized to maximize efficiency.	Evidence that some resources utilized meeting intended purpose.	A few resources (e.g., tools & materials) utilized randomly.	
Technical Criteria					
Programming (Autonomous and/or tele-op)	Efficiency and sophistication evident in multiple programs.	Consistency evident in one or more programs.	Functional, but inconsistent programming.	Programming incomplete or rarely functional.	
Control Systems	Completely functional and consistent control systems.	Consistently functional control systems.	Functional, but inconsistent control systems.	Non-functional or incomplete control systems.	
Electrical Systems	Completely functional and consistent electrical systems.	Consistently functional electrical systems.	Functional, but inconsistent electrical systems.	Non-functional or incomplete/unsafe electrical systems.	
Mechanical Systems	Completely functional and consistent mechanical systems.	Consistently functional mechanical systems.	Functional, but inconsistent mechanical systems.	Non-functional or incomplete/unsafe mechanical systems.	
Fluid Systems (pneumatics, hydraulics, etc.)	Completely functional and consistent fluid systems.	Consistently functional fluid systems.	Functional, but inconsistent fluid systems.	Non-functional or incomplete/unsafe fluid systems.	
Unifying Themes (This area emphasizes the Interaction of Science, Technology, & Human Endeavor)					
Communication (written & oral)	Sophisticated and highly efficient communication for all audiences.	Purposeful, consistent, effective communication.	Purposeful, fairly consistent communication.	Communication very inconsistent and lacks purpose.	
Teamwork	Integrated teamwork that maximizes outcomes is evident.	Participants fully define roles, goals, & work together.	Participants partially define roles, goals, & work together.	Participants function separately within a group.	
Ethics in Decision-Making	Ethical behavior is fully exhibited and advocated for throughout the process.	Decisions guided by design constraints, Asimov's laws, and interpersonal ethics.	Ethical decisions concerning design constraints evident.	Ethics considered, but not applied to decisions.	

FINAL EVENT - Manufacturing Workcell

LEVEL: _____ Elementary _____ Middle School _____ High School _____ Post Secondary

SCHOOL: _____

CAPTAIN: _____

Documentation Inspected (ie. Engineers Notebook or Portfolio) Yes: _____ **No:** _____

Judging Criteria	Expert	Proficient	Emergent	Novice	Points Awarded
Creating Viable Solutions to a Variety of Human Wants, Needs, and Challenges.	50	40	30	20	
Simple and Complex Systems	50	40	30	20	
Design Process (scientific method, technological problem solving process, etc.)	50	40	30	20	
Utilization of Resources: (Tools/ Machines, Materials, Information, People, Capital, Energy, & Time)	50	40	30	20	
Programming (Autonomous)	50	40	30	20	
Control Systems	50	40	30	20	
Electrical Systems	50	40	30	20	
Mechanical Systems	50	40	30	20	
Communication (written and oral)	50	40	30	20	
Teamwork	50	40	30	20	
Ethics in Decision-Making	50	40	30	20	
Total points available	550				
Total points awarded					

Judge's Comments:

Judge's Signature: _____

Micromouse Contest

Middle School, High School, Post-Secondary

Contest Description

In the Micromouse Contest, the contestant or team of contestants design and build a small self-contained robot (Mouse) to negotiate a right/left turn maze in the shortest possible time.

The following rules were adapted from the 1986 official rules for the North American Micromouse Contest.

Rules

1. The micromouse robot shall be self-contained (no remote controls). A micromouse robot shall not use an energy source employing a combustion process.
2. A micromouse robot shall not leave any part of its body behind while negotiating the maze.
3. A micromouse robot shall not jump over, fly over, climb, scratch, cut, burn, mark, damage, or destroy the walls of the maze.
4. A micromouse robot shall not be larger than 7" x 7" x 7"
5. Micromouse robots outside the criteria in rules 1 through 4 must be brought into compliance before being allowed to compete.
6. The maze is composed of multiple 10-inch by 10-inch square sections. The walls of the maze are 3 inches high and .75 inches thick (**assume a 5% tolerance for mazes**). Thus, the internal navigable area within a square is 9.25 inches by 9.25 inches. The maze comprises up to 10 x 10 unit squares for a total maze size of up to 100 sections. The outside wall encloses the entire maze.
7. The sides of the maze walls are painted white, the floor of the maze is painted black and the top of the walls may be any color or unpainted. The maze is made of wood, finished with non-gloss paint with aluminum 80/20 posts on each corner of the 10" x 10" sections.
8. **WARNING:** Do not assume the walls, the tops of the walls, or the floor are consistently white or black. Fading may occur; parts from different mazes may be used. Do not assume the floor provides a given amount of friction. It is simply painted plywood and may be quite slick. There may be a seam between the two sheets on which any low-hanging parts of a robot may snag.
9. The start of the maze is located at one of the four corners. The start square is bounded on three sides by walls. The start line is located between the first and its second squares. That is, as the robot exits the corner square, the time starts. The destination goal is the four cells at the center of the maze. The destination square has only one entrance.
10. Multiple paths to the destination square are allowed and are to be expected. The destination square will be positioned so that a wall-hugging robot will not be able to find it.
11. Each robot is **not** allocated any time to access the maze prior to its first run. Contestants have 10 minutes total to complete as many runs as they wish. Any time used to adjust a robot between runs is included in the 10 minutes. Each run (from the start cell to the center zone) in which a robot successfully reaches the destination square is given a run time.
12. The minimum run time shall be the robot's official time.
13. If a robot is in mid-run when the ten minute total time elapses, that attempt is finished and does not count. If no robots (or less than 3) finish their runs in under ten minutes, the ranking will be determined by the sole discretion of the judges.
14. Robots that do not enter the center square will be ranked by the maximum number of cells they consecutively transverse without being touched. However, judges are not required to give any rankings to robots who do not finish and may declare no winners or declare less than three winners at their discretion.
15. Two timers are used for each contestant. One for the ten-minute total time and a separate timer for each run within the total time.
16. The initial run shall be made from a random one of the four possible starting squares. Following runs within the 10 minutes allowed shall all be from the same starting square as the first run.
17. If a robot has already crossed the finish line, it may be removed at any time without affecting the run time of that run. If a robot is placed back in the maze for another run, a one-time penalty of 30 seconds will be added to the robot's best time.

18. The operator may abort a run at any time. If an operator touches the robot during a run, it is deemed aborted, and the robot must be removed from the maze.
19. If a robot has already crossed the finish line, it may be removed at any time without affecting the run time of that run.
20. After the maze is disclosed, the operator shall not feed information on the maze into the robot. However, switch positions may be changed for the purpose of changing programs within the robot (changing algorithms is allowed. Entering info on the maze is not allowed and does not constitute "changing algorithms".)
21. The amount of sunlight, incandescent light, or fluorescent light that may be present at the contest site will vary based on the contest location and environmental factors. Teams should plan accordingly.
22. The run timer will start when the front edge of the robot crosses the start line and stops when the front edge of the robot crosses the finish line.
23. The start line is at the boundary between the starting unit square and the next unit square. The finish line is at the entrance to the destination square.
24. Every time the robot leaves the start square, a new run begins. If the robot has not entered the destination square, the previous run is aborted. For example, if a robot re-enters the start square (before entering the destination square) on a run, that run is aborted, and a new run will be deemed begun, with a new time that starts when the starting square is exited.
25. The robot may, after reaching the destination square, continue to navigate the maze for as long as their total maze time allows.
26. If a robot continues to navigate the maze after reaching the destination square, the time taken will not count toward any run. Of course, the 10-minute timer continues to run. When the robot next leaves the start square, a new run will start. Thus, a robot may and should make several runs without being touched by the operator. It should make its own way back to the beginning to do so.
27. The judges reserve the right to ask the operator for an explanation of the micromouse robot. The judges also reserve the right to stop a run, declare disqualification, or give instructions as appropriate (e.g., if the structure of the maze is jeopardized by continuing operation of the robot).
28. A contestant may not feed information on the maze to the micromouse robot. Therefore, changing ROMs or downloading programs is NOT allowed once the maze is revealed.
However, contestants are allowed to:
 - a. Change switch settings (e.g., to change algorithms (for example, from left-turning to right-turning - again, entering data on maze size or content is NOT inclusive of this rule.)
 - b. Replace batteries between runs
 - c. Adjust sensors
 - d. Change speed settings
 - e. Make repairs
29. A contestant may not alter a robot in a manner that alters its weight (e.g. removal of a bulky sensor array or switching to lighter batteries to get better speed after mapping the maze is not allowed).
30. All robots, whether or not they have competed in previous contests, compete on an equal basis.
31. The robot must meet all other qualifications and must be presented to the judges by the original design team at the time designated in the official contest schedule.
32. Once checked in, the robot will remain at the judges' station until the team's time to run.
33. A pit area, with access to a 110-volt standard outlet, will be provided.
34. Teams must bring documentation of their design process and the iterations that have taken place during the current school year. (i.e., Engineers Notebook or Portfolio)
35. Decisions of the judges are final and binding.

EXAMPLE - Maze

NOT ACTUAL MAZE LAYOUT

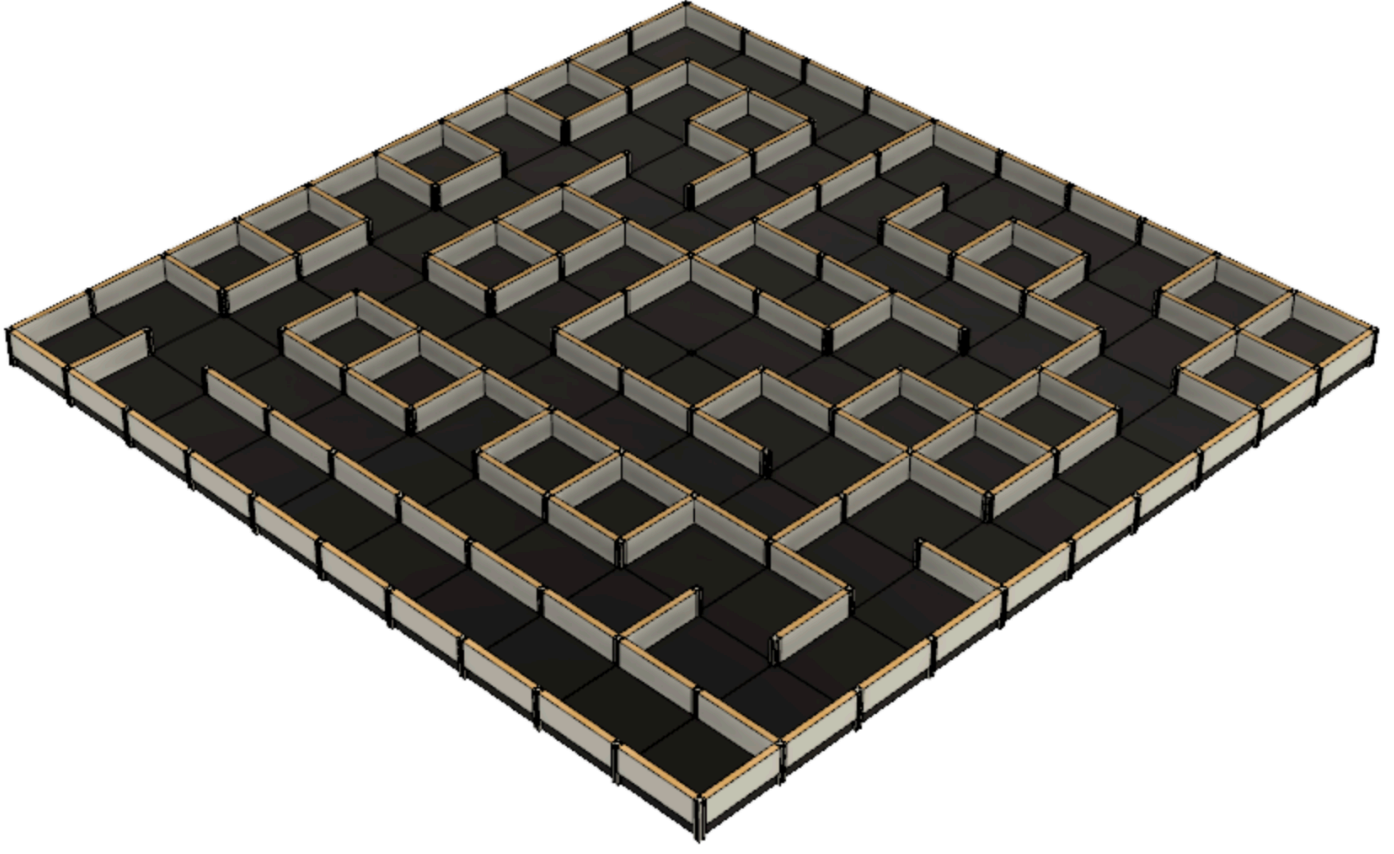

Pre-Competition Device Evaluation/ Interviews – Micromouse Contest

LEVEL: _____ Middle School _____ High School _____ Post Secondary

SCHOOL: _____

CAPTAIN: _____

Documentation Inspected (ie. Engineers Notebook or Portfolio) Yes: _____ No: _____

Judging Criteria

Size Requirements	
(maximum) 7" wide 7" long 7" high	Check if the requirement has been met. _____
Fastest Maze Run	

Entries not meeting any of the above criteria must be brought into compliance before being allowed to compete.

Judge's Comments:

Judge's Signature: _____

Mini-Sumo Robot

Elementary, Middle School, High School

Contest Description

The Mini-Sumo Robot Contest requires a student team to build a self-propelled, self-controlled, sensing robot designed to force another Sumo Robot outside a four (4) foot competition ring. The competition ring will be a square painted flat black, measuring 4' across. There is an inside square surrounded by a one-inch (1") wide, painted or taped, flat white square. Another white one-inch (1") wide line will surround the inner ring with one-inch (1") between them. When any part of the robot crosses completely over the 1" white outer line while being pushed by the opposing robot, it will lose the heat.

Rules

1. The Sumo must be powered by electrical storage batteries. No other power sources will be allowed. These batteries must be sealed, and all possible precautions must be incorporated into the design to prevent accidental spills. The judges may disqualify any design that is determined to be unsafe.
2. Plastic (PET, PETG, ABS, PLA, etc.) is the only material that can be used for the chassis and body of the robot. No other types of materials are allowed (i.e., metal, carbon fiber, wood)
3. Motors, electronics, axles, fasteners, and adhesives can be any material but cannot be used in such a way to enhance the structural integrity, armor the robot, or enhance any defenses.
4. A robot may be disqualified at the Event Organizer's discretion if it is deemed to violate the spirit of rules 2 or 3. Contact the event organizer ahead of time if you are not sure your robot meets the above criteria.
5. The Sumo must use sensing devices to govern the motion of the Sumo and must use sensors to detect the other Sumo and/or the edge of the white circle.
6. Robots cannot exceed 1.5 Kilograms in weight.
7. Robots cannot exceed a maximum size of 20cm x 20cm x 20cm. Any robot entered that does not meet the size requirement by the end of the device evaluation or expands beyond that size during competition will be disqualified. **Device evaluation will take place at the time indicated on the Official Schedule.**
8. The Sumo Robot drive wheels **must** be non-destructive to the playing surface.
9. The Sumo Robot may not have a remote off/on switch.
10. Double elimination contests will decide the winner of the contest.
11. At the beginning of each competition, with the power switch in the "off" position, the Sumo handler(s) will position their Sumo as instructed by the judges. Four start configurations will be possible:

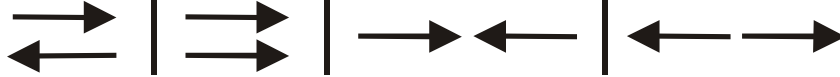

- At the command of the judge/facilitator, the handler(s) will turn the power switch to the "on" position.
9. **(New for 2026)** When one robot causes **any part** of their opponent to go past the outer white line, that robot is declared the winner of that engagement. To be a loss the robot must have been pushed out by the opposing robot. Driving beyond the outer white line while not under direct contact with an opponent does not constitute a "win" and is declared a "fault".
 10. **(New for 2026)** If a fault is declared, the robots are positioned in the same starting position, and the contest begins anew.
 11. **(New for 2026)** If a robot causes three faults, the other robot is declared the winner of the match.
 12. **(New for 2026)** If both Sumos leave the ring at the same time, a "no-contest" is declared, and the two Sumos are repositioned, and the contest begins anew.
 13. **(New for 2026)** If, after one minute, no winner is declared, the contest is determined to be a "draw," and the two Sumos are randomly repositioned in one of the possible start configurations, and the contest begins anew. If three encounters in a row end in a "draw", the judges shall declare a winner based on action observed within the ring and on the design of the selected Sumo robot.
 12. A pit area, with access to a 110-volt standard outlet, will be provided.
 13. Teams must bring documentation of their design process and the iterations that have taken place during the current school year. (i.e., Engineers Notebook or Portfolio)
 14. Decisions of the judges are final and binding.

Mini-Sumo Ring Details

Isometric View of the Mini-Sumo Competition Ring

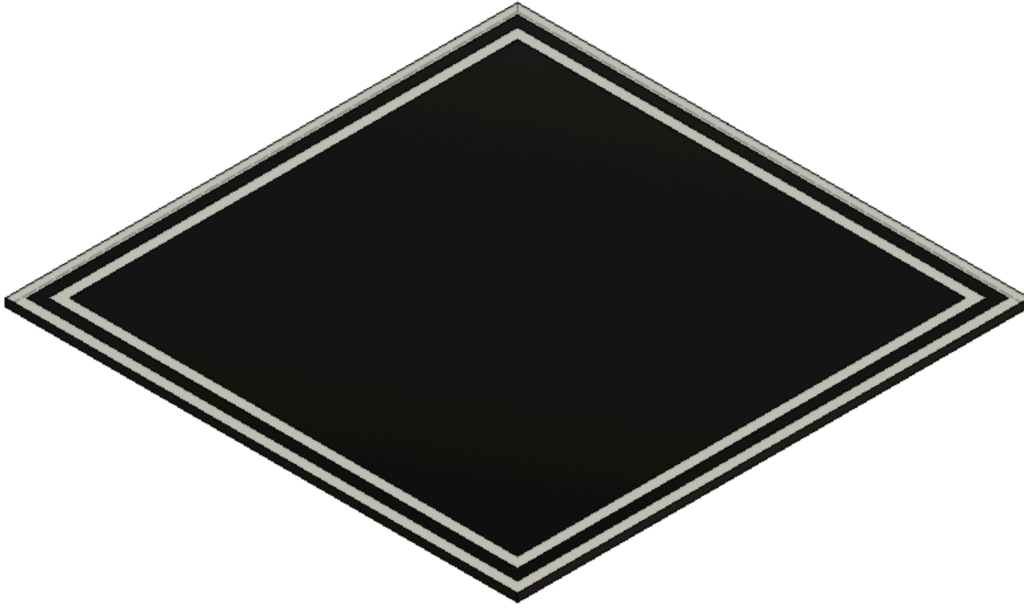

Close-up detail of the lines with dimensions

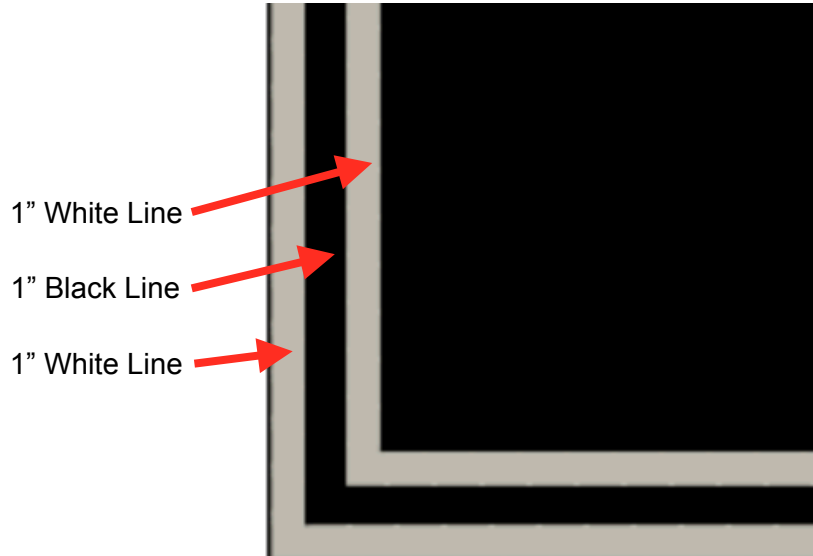

Pre-Competition Device Evaluation/ Interviews Mini-Sumo Robot

LEVEL: _____ Elementary _____ Middle School _____ High School

SCHOOL: _____

CAPTAIN: _____

Documentation Inspected (ie. Engineers Notebook or Portfolio) Yes: _____ No: _____

Criteria

Sumo Weight	
Weight Size Requirements <i>(Maximum 1.5 Kg)</i>	Weight = _____
Sumo Measurements	
Size Requirements <i>(maximum 20cm x 20cm x 20cm)</i>	Check if within size requirements _____

Elimination Heats will be held at the time published on the Official Schedule

Entries not meeting any of the above criteria must be brought into compliance before being allowed to compete.

Judge's Comments:

Judge's Signature: _____

Rescue Robot

Middle School, High School

Contest Description

In the Rescue Robot contest, the participants build a remote controlled vehicle able to operate within a 18-foot long and 10-foot wide playing field. The vehicle is to travel the field and pick up four colored ping-pong balls from four holding devices (pick pylons) locations and place them into a receiving jig (drop pylons). The event is intended to simulate the environment a robot might be required to navigate in the event of a building collapse.

Rules

1. Each remote-controlled vehicle (RCV) must be designed and constructed by the student(s).
2. Out-of-box RCVs are not allowed. However, out-of-box RCVs may be dismantled and components used to construct a modified RCV; maximum out-of-box content shall be 40%.
3. The RCV shall not exceed 18" in width, 18" in length, and 10" in height at the beginning of each match. Vehicles outside the size criteria must be brought into compliance before being allowed to compete. Once the match has begun, the RCV can expand beyond the beginning size.
Device evaluation will take place at the time indicated on the Official Schedule.
4. Each vehicle must have the ability to change between at least two different frequencies or utilize a transmitter/control technology that features frequency binding.
5. Double elimination matches will decide the winner of the contest.
6. **(New for 2026)** At the beginning of the match the judge will randomly assign which color ping pong ball each robot will retrieve. There are four (4) pick pylons for each robot, one set of orange and one of white. There will be two drop pylons, one orange and one white, that the team must place their color ball onto.
7. The starting line for the RCV will be designated on the playing field.
8. **ONE** team member will be the designated operator during the timed evaluation. Once the match has begun, only the designated operator and/or the judge(s) may contact the vehicle, controller, and any part of the vehicle or playing surface.
9. The designated operator must stand in the designated operator area, as directed by the judging team.
10. Each robot must stay on its own side of the middle barrier. Any robot crossing mid-field will forfeit that match.
11. **(New for 2026)** The robot must incorporate some type of imaging sensor or camera that can wirelessly transmit visual data to the operator for navigation, where line-of-sight between the operator and vehicle is impossible. All robot movement will be beyond the visible line of sight for the operator.
12. If a ping-pong ball is dropped inside the playing field, the robot can retrieve it and continue play.
13. If a ping-pong ball is dropped outside of the playing field, the judge will return it to its original holding device.
14. If a vehicle becomes immobilized for any reason, the designated operator may ask a judge to return the vehicle to the start position. If the vehicle is in the process of moving a ball, that ball must be returned to the holding device that it originated from. There will be no penalty other than having to begin from the start position.
15. Each match will be 3 minutes in length. If one team retrieves all four ping-pong balls of their designated color, the match ends, and they are declared the winner.
16. If, at the end of 3 minutes, both teams have the same number of ping-pong balls in the receiving jigs, then the 1st team that scored is the winner. If neither team has scored, the match continues until the first ball is scored, and that team is declared the winner.
17. Robots should be designed to traverse an environment that would result from a residential building collapse. (i.e., bricks, stone rubble, collapsed beams, wood/steel studs, stairs, inclines from collapsed walls)
18. The playing field layout will not be released prior to Thursday of the NRC. Prepare accordingly.
19. A pit area, with access to a 110-volt standard outlet, will be provided.
20. Teams must bring documentation of their design process and the iterations that have taken place during the current school year. (i.e., Engineers Notebook or Portfolio)
21. Decisions of the judges are final and binding.

Pick Pylon – Rescue Robot

Note: Height of Pick Pylons will be between 3" and 6" off of the base surface.

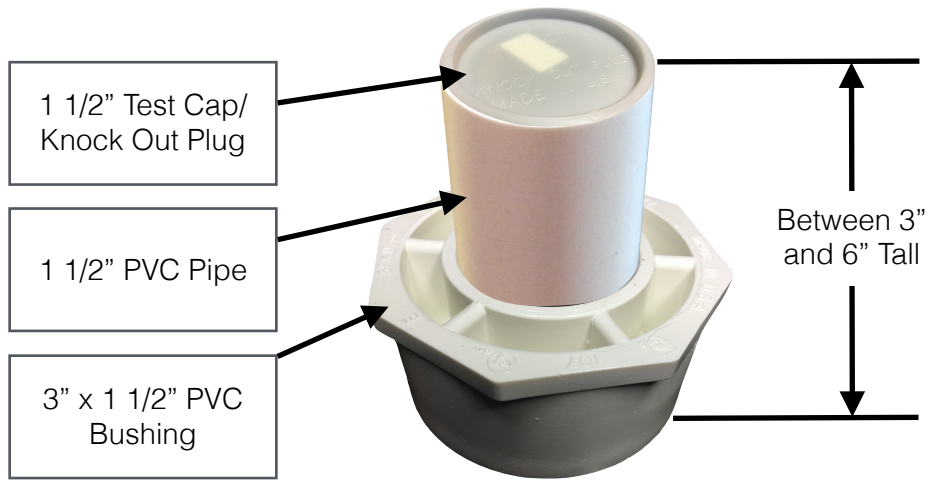

Drop Pylon – Rescue Robot

Note: Drop Pylons will be filled with dry sand for mass and stability. Pylon is 4 inches high.

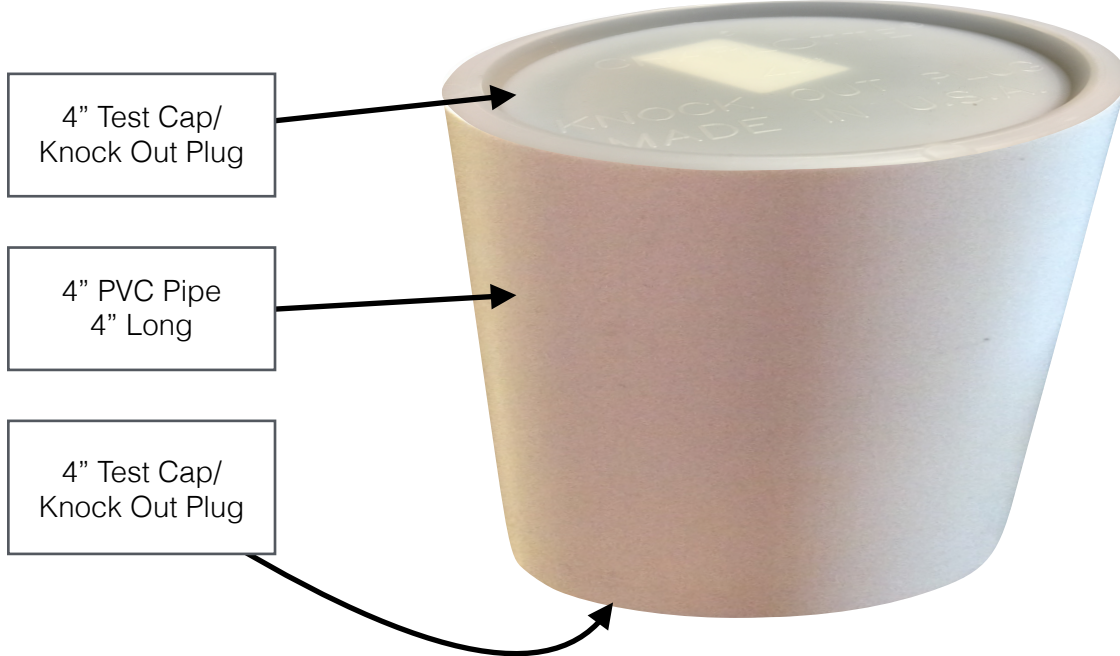

Pre-Competition Device Evaluation/ Interviews – Rescue Robot

LEVEL: _____ Middle School _____ High School

SCHOOL: _____

CAPTAIN: _____

Documentation Inspected (ie. Engineers Notebook or Portfolio) Yes: _____ No: _____

Judging Criteria

Rescue Robot	
<i>(Maximum out-of-box content is 40%)</i>	Check if the requirement has been met. _____
Size Requirements	
<i>(maximum)</i> 18" wide 18" long 10" high	Check if the requirement has been met. _____

Entries not meeting any of the above criteria must be brought into compliance before being allowed to compete.

Judge's Comments:

Judge's Signature: _____

Robo Hockey

Remote-Controlled
Middle School, High School

Contest Description

The Robo Hockey contest requires a student team to build **two** remote-controlled robots that will compete in a simulated hockey event against two robotic opponents. The team that scores the most goals in a three-minute match wins. The event is held in a double-elimination format tournament.

Rules

1. The robot must be powered by electrical storage batteries. No other power sources will be allowed. These batteries must be sealed, and all possible precautions must be incorporated into the design to prevent accidental spills.
2. Each robot must be radio-controlled with the ability to change between at least two different frequencies.
3. **(New for 2026)** The robot must fit inside a 12" x 12" x 12" space and cannot exceed 10 pounds. Any robot entered that does not meet the size requirement by the end of the device evaluation will be disqualified.
4. Only the shooting mechanism may expand beyond the 12" x 12" x 12" size during competition. This mechanism may extend for shooting the "puck" ONLY and must immediately withdraw to within the 12" x 12" x 12" envelope. At no time may the shooting mechanism be extended to block the goal, another robot, or as a defensive move.
5. **Device evaluation will take place at the time indicated on the Official Schedule**
6. The robot drive wheels **must** be non-destructive to the playing surface.
7. This event is a full-contact sport. Due to the rough nature of the match, robots may suffer damage. If both robots on a team are damaged beyond repair, the team must forfeit the match.
8. Any robot that is deemed too dangerous to the hockey field, judges, or spectators by the NRC staff or judges will be disqualified.
9. At the conclusion of each match the winning robot must be weighed to ensure that legal weight has been maintained.
10. Robots may have a maximum speed of 10 feet per second.
11. Double elimination contests will decide the winner.
12. At the beginning of each competition the robot handler(s) will position their robot on the playing surface. Each robot will start in one of the four corners of the playing surface. At the command of the judge/facilitator, the handler(s) will begin the contest.
13. Each robot may have a maximum storage of 200 PSI and a maximum kinetic PSI of 100
14. A robot may not at any time enclose more than 50% of the hockey puck (sides or top)
15. A robot may never intentionally lift the hockey puck.
16. Each match will be three minutes in duration. Time will **NOT** stop on a penalty or score.
17. A team is automatically declared the winner if they score eight goals more than the opposing team.
18. In the event of a tied score at the end of time, the team that scored the first point in the match is declared the winner. In the event of a 0-0 score, the match will be determined with a shootout. Each team will shoot one foot from the goal line and will continue moving back from the goal one additional foot until a team fails to score.
19. Matches will use a Franklin NHL Roll-A-Puck Street/Roller Hockey Puck.
20. At the beginning of the match the puck will be placed in the center of the playing surface.
21. Each robot must have an actuator that can "shoot" the puck when the robot is in a stationary position.
22. Scoring: A point will only be scored if the puck was shot outside of the goal's perimeter and **completely** passes the goal line. The puck entering the goal as a result of only impacting a moving robot does not count as a "shot." ie. Shooter does not engage the puck.
23. No robot is allowed inside either team's goal perimeter.
24. A pit area, with access to 110-volt standard outlet, will be provided

25. Teams must bring documentation of their design process and the iterations that have taken place during the current school year. (i.e., Engineers Notebook or Portfolio)
26. Decisions of the judges are final and binding.

Penalties:

1. If a team gets two penalties, their opponent scores one point.

Grounds for a Penalty:

- a. Intentionally going within a goal perimeter
- b. Extending the Shooting mechanism to block or as a defensive move

Arena Specifications:

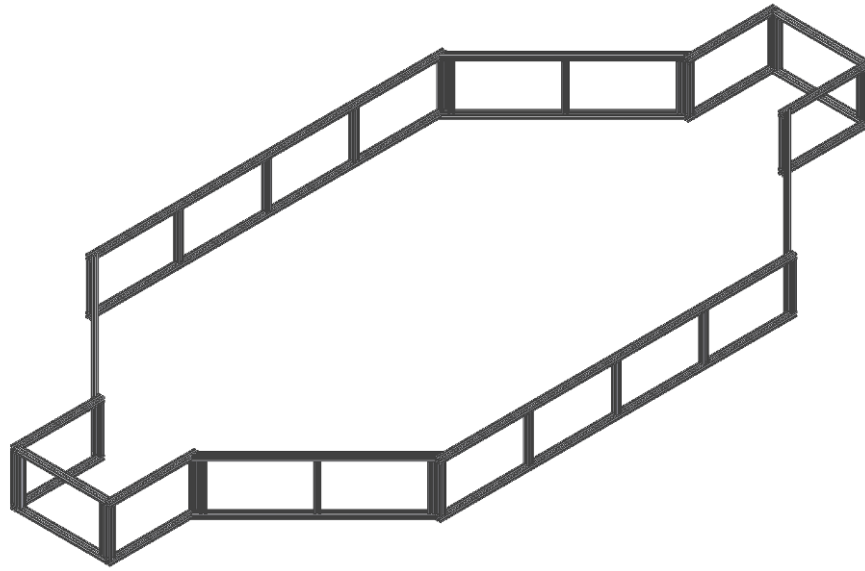

Top View of the Arena

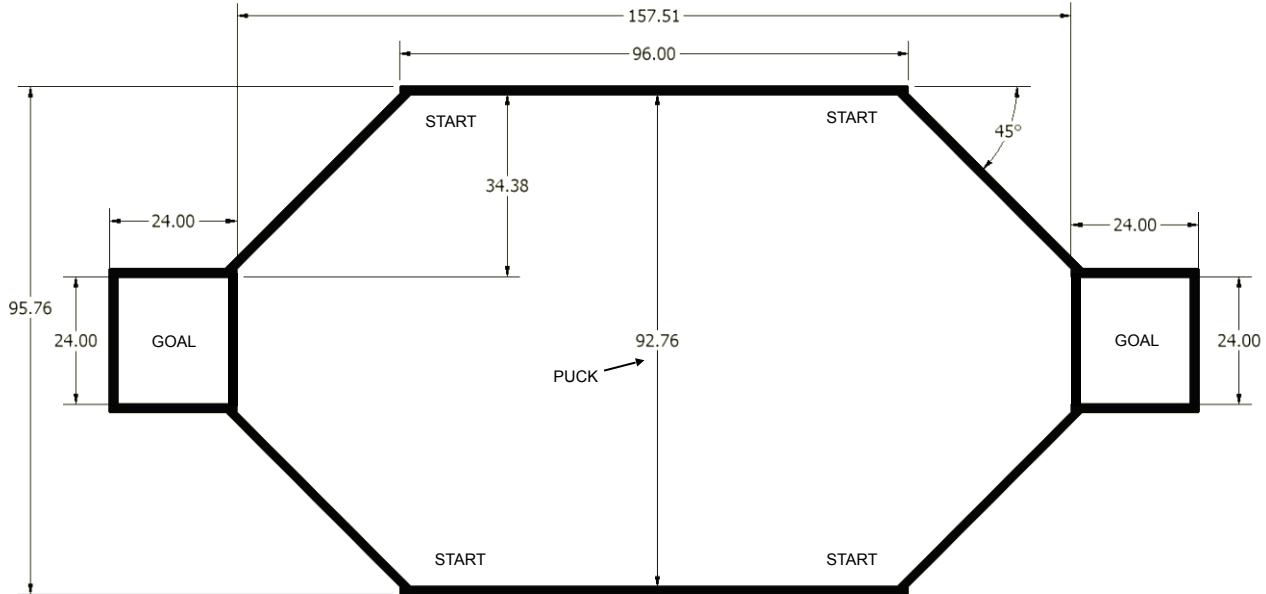

Pre-Competition Device Evaluation/ Interviews Robo Hockey

LEVEL: _____ Middle School _____ High School _____ Post Secondary

SCHOOL: _____

CAPTAIN: _____

Documentation Inspected (ie. Engineers Notebook or Portfolio) Yes: _____ No: _____

Criteria

Robot Weight	Robot 1	Robot 2
Weight Requirements (≤ 10 Pounds)	Weight =	Weight =
Robot Requirements	Check if the requirement has been met.	
Size Requirements (maximum 12" x 12" x 12")	_____	_____
Energy Storage Requirements maximum storage of 200 PSI	_____	_____
maximum kinetic PSI of 100	_____	_____
maximum speed of 10 feet per second	_____	_____
robot has an actuator that can "shoot" the puck when the robot is in a stationary position	_____	_____

***Entries not meeting any of the above criteria must be brought
into compliance before being allowed to compete.***

Judge's Comments:

Judge's Signature: _____

Robot Maze Contest

Elementary, Middle School, High School

Contest Description

In the Robot Maze Contest, students use a robot to navigate a right/left turn maze.

Rules

1. A single-level right and left turn maze will be used.
2. Any type of commercially available or student-fabricated robot is eligible. Umbilical cords and wireless control devices **will not** be allowed.
3. The maximum physical size of the robot shall not exceed 7" x 7" x 7" high. For each one-half inch (1/2") that exceeds the maximum limitation, five (5) seconds will be added to the robot's elapsed time. Note: The maze runways are approximately 9.25 inches wide and wall are 3 inches high. **Device evaluation will take place at the time indicated on the Official Schedule.**
4. The maze is composed of multiple 10-inch by 10-inch square sections. The walls of the maze are 3 inches high and .75 inches thick (assume 5% tolerance for mazes). Thus, the internal navigable area within a square is 9.25 inches by 9.25 inches. The outside wall encloses the entire maze.
5. The sides of the maze walls are painted white, the floor of the maze is painted black, and the top of the walls may be any color or unpainted. The maze is made of wood, finished with non-gloss paint with aluminum 80/20 posts on each corner of the 10" x 10" sections.
6. The robot must not cross over any walls and must remain in contact with the maze floor at all times.
7. **WARNING:** Do not assume the walls, the tops of the walls, or the floor are consistently white or black. Fading may occur; parts from different mazes may be used. Do not assume the floor provides a given amount of friction. It is simply painted plywood and may be quite slick. There may be a seam between the two sheets on which any low-hanging parts of a robot may snag.
8. Each robot is allowed three (3) runs, with the best time being considered the official time.
9. The maximum time to complete the maze is five minutes.
10. Once a run begins, touching the robot ends that attempt.
11. A blueprint of the maze listing the exact dimensions is on the next page.
12. Scoring is based on the following:
 - a. The shortest elapsed time for completion of the maze from the starting line to the finish line will be used to determine the winner in each division. The time will start when the front of the mouse crosses the start line and will stop when the robot completely crosses the finish line.
 - b. In the event of a tie for first place, each team will be allowed two additional runs. The team with the best time is the winner and the other team is awarded second place.
 - c. If the results of the second run are also a tie, contestants will be asked to make an oral presentation showing the logic used to develop the robot and how the robot uses information received by the sensors to determine the path through the maze.
13. A pit area, with access to 110-volt standard outlet, will be provided.
14. Teams must bring documentation of their design process and the iterations that have taken place during the current school year. (i.e., Engineers Notebook or Portfolio)
15. Decisions of the judges are final and binding.

Robot Maze

High School

Isometric View of Complete Maze

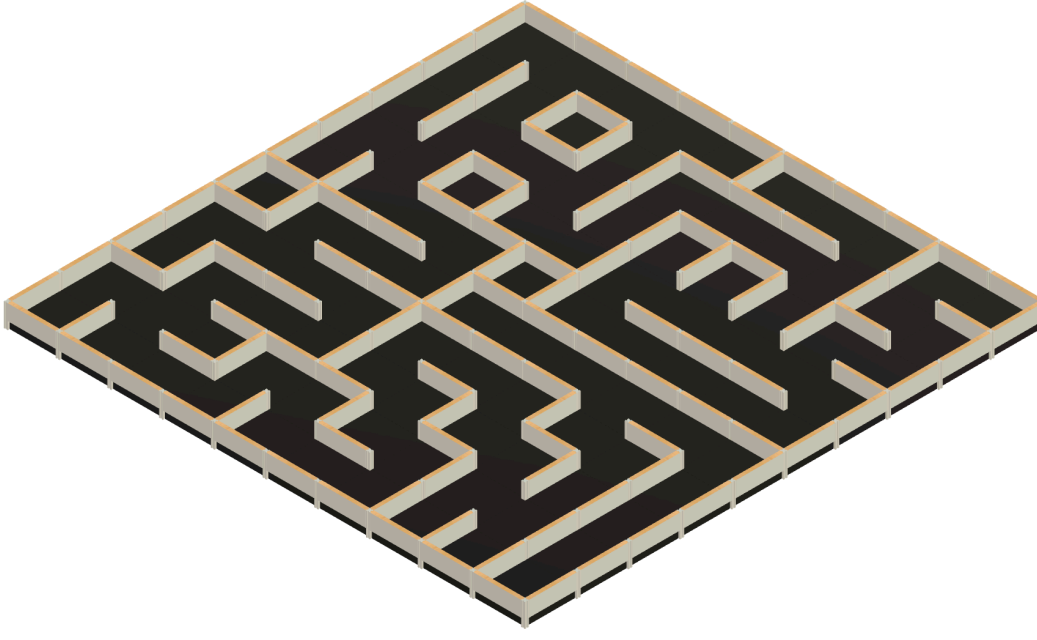

Top View of Complete Maze

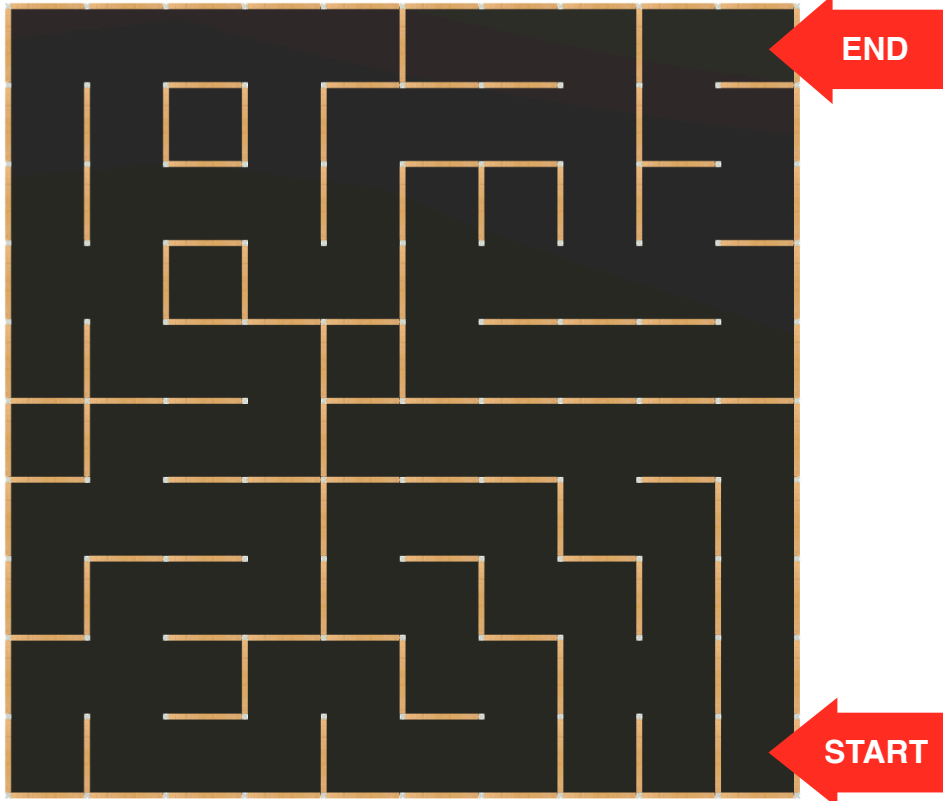

Robot Maze

Elementary / Middle School

Isometric View of Complete Maze

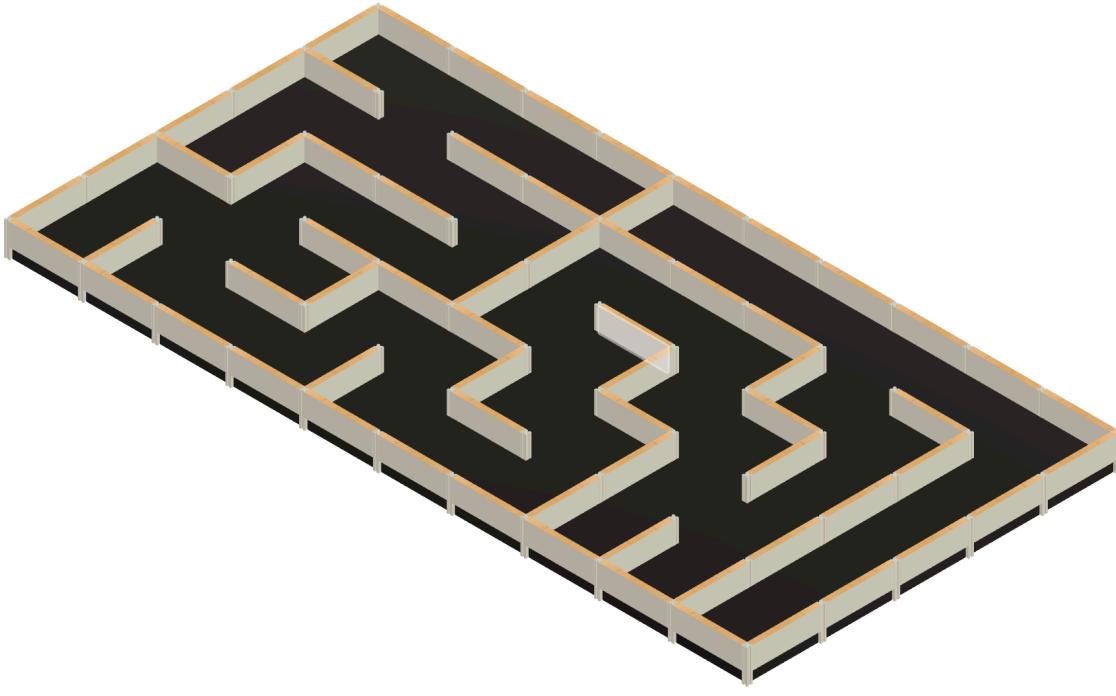

Top View of Complete Maze

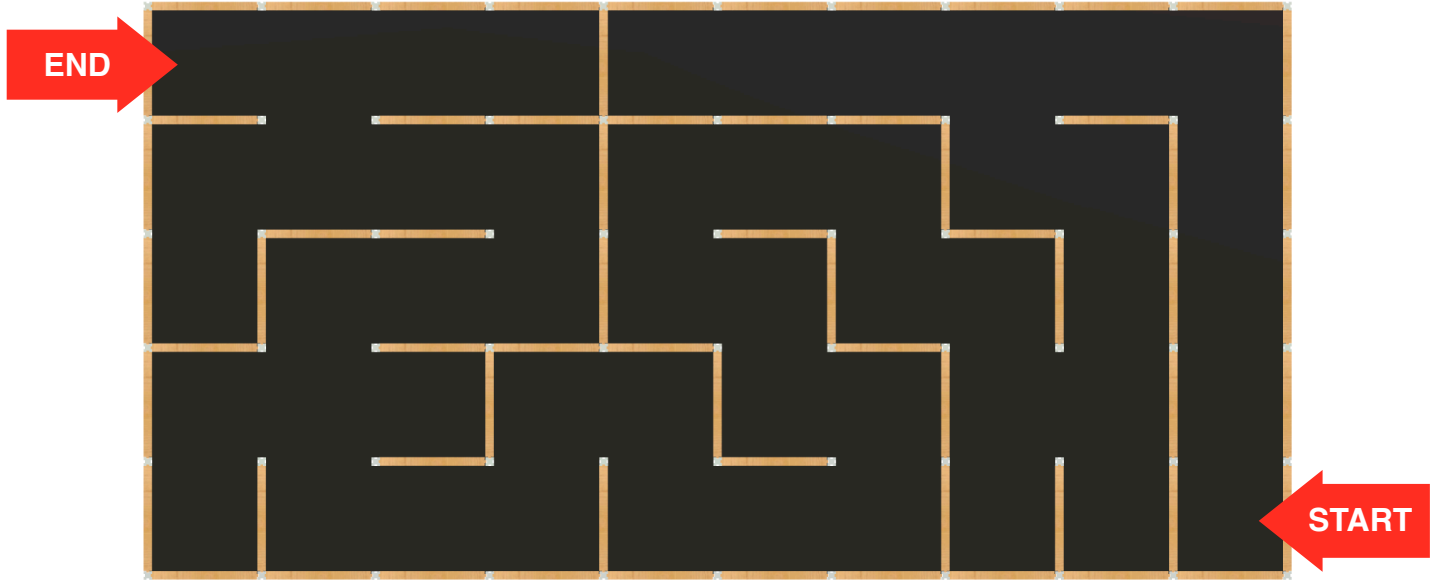

FINAL EVENT - Robot Maze Contest

LEVEL: _____ Elementary _____ Middle School

SCHOOL: _____

CAPTAIN: _____

1. Penalty for Oversize
2. Time required to complete course (seconds): Best time out of 3 runs will be official time
3. Final Scoring Totals (Note, lower scores are better than higher scores)

Documentation Inspected (ie. Engineers Notebook or Portfolio) Yes: _____ No: _____

Criteria	Size requirement 7"x7"x7" high	Measure and indicate if it exceeds size requirement by number of one-half inches (1/2")	Total
Number of one-half inches (1/2") entry exceeds size requirement			
Penalty Seconds			x 5
1. Total Penalty Seconds for Oversize To Add to Elapsed Run Time			
First Run			Subtotal
Time required to complete course			
Total Time for First Run			
Second Run			Subtotal
Time required to complete course			
Total Time for Second Run			
Third Run			Subtotal
Time required to complete course			
Total Time for Third Run			
Best Run (From Run 1, 2, or 3)			Total
2. Time required to complete course			
			Total Points
Penalty for Oversize (if any) (from #1)			
Best Time in Seconds (from #2)			
FINAL SCORE			

								61	62	
				50	51	52	53	60	59	
	44	45	46	49				54	57	58
	43		47	48				55	56	
	42	41	40							
	37	38	39				7	6	5	
	36	35	34	17	16	15	8	9	4	
	31	32	33	18	19	14	13	10	3	
	30		26	25	20	21	12	11	2	
	29	28	27	24	23	22			1	



	38	37						7	6	5
	36	35	34	17	16	15	8	9	4	
	31	32	33	18	19	14	13	10	3	
	30		26	25	20	21	12	11	2	
	29	28	27	24	23	22			1	



Judge's Comments:

Judge's Signature: _____

Robot Problem Solving

Middle School, High School

Contest Description

In the Robot Problem Solving Contest, students use a computer software program and a small robotic arm to solve a problem that occurs in a typical manufacturing plant.

Rules

1. This is a team competition, and a team consists of two (2) students from a single school and division.
2. Each team will provide their own computer and power strip for the competition and a VEX CTE Workcell kit from vexrobotics.com
 - a. Any additional equipment and/or supplies will be provided at the competition
3. Scoring is based on the elapsed time required to run the program (30%), completion of the given problem (30%), and creativity of the solution (40%).
4. The team will be given a problem to solve using only their computer, VEX CTE Workcell kit, and the supplies provided by the National Robotics Challenge personnel.
5. Each team will have three (3) hours to solve the given problem and program their robot.
6. As each team completes their solution they will notify the National Robotics Challenge staff and can be judged at that time.
7. A team table with two chairs and access to a 110-volt standard outlet will be provided.
8. Decisions of the judges are final and binding.

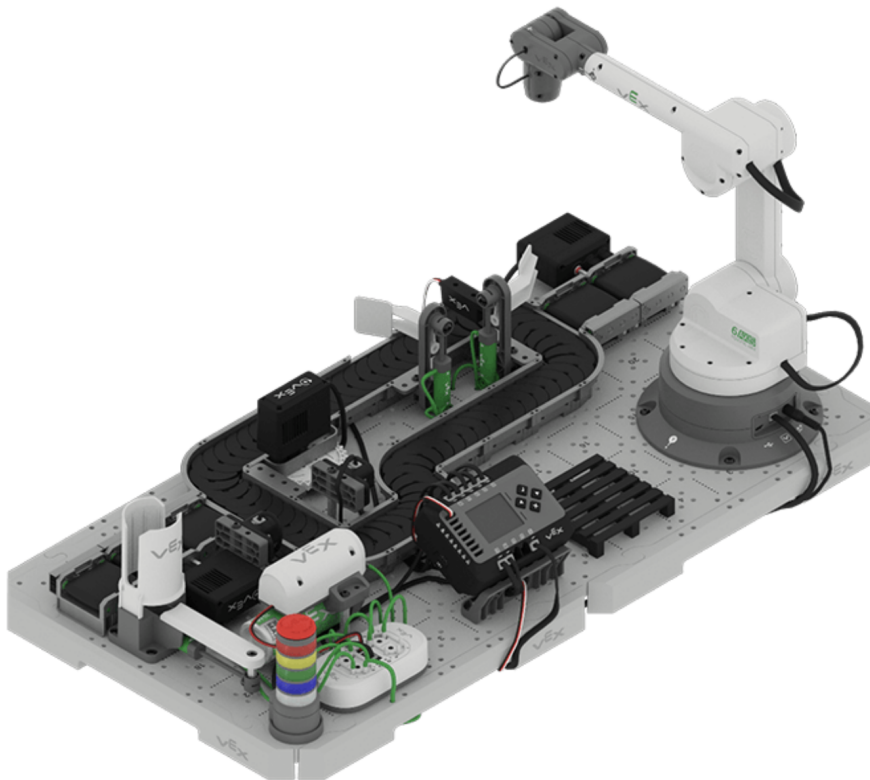

Sumo Robot

Self-Controlled - Middle School, High School, Post-Secondary

Contest Description

The Sumo Robot Contest requires a student team to build a self-propelled, autonomous, sensing robot designed to force another Sumo Robot outside a ring. The competition ring will be a square painted flat black, measuring 8' across. There is an inside square surrounded by a two-inch (2") wide, painted or taped, flat white square. Another white one-inch (1") wide line will surround the inner ring with 2 inches (2") between them. When any part of the robot crosses completely over the 1" white outer ring while being pushed by the opposing robot, it will lose the heat.

Rules

1. The robot must be powered by electrical storage batteries. No other power sources will be allowed. These batteries must be sealed, and all possible precautions must be incorporated into the design to prevent accidental spills. The judges may disqualify any design that is determined to be unsafe.
2. If a design incorporates non-electric actuators (i.e., pneumatics, hydraulics), all power must come entirely from onboard sources powered by electricity. For example: if a robot uses a pneumatic cylinder to run an arm, the robot would need to include an on-board air pump to provide the air pressure for operation.
3. **(New for 2026)** Robots must be self-controlled and use sensing devices to govern their motion. Robots must use sensors to either detect the other robot and the white line.
4. **(New for 2026)** All Sumo components **must** be non-destructive to the playing surface.
5. **(New for 2026)** No component can be deliberately designed to drag on the playing surface during locomotion.
6. **(New for 2026)** All robots must have easily visible and controlled mobility in order to compete. Methods of mobility are limited to:
 - 6.1. Walking: Walking robots have no rolling elements in contact with the floor and no continuous rolling or cam-operated motion in contact with the floor, either directly or via a linkage. Motion is "continuous" if continuous operation of the drive motor(s) produces continuous motion of the robot.
 - 6.2. Shuffling (rotational cam-operated legs)
7. **(New for 2026)** Rolling methods of robot mobility are not permitted. (wheels, tracks, or the whole robot)
8. Any robot that is deemed too dangerous to other robots, the playing surface, or competitors will be disqualified.
9. Robot Size Limitations:
 - a. Middle School Division: The robot must fit inside a 20" x 20" x 20" space and weigh less than 15 lbs.
 - b. High School Division: The robot must fit inside a 20" x 20" x 20" space and weigh less than 20 lbs.
 - c. Post-Secondary Division: The robot must fit inside a 20" x 20" x 20" space and weigh less than 20 lbs.
10. Any robot entered that does not meet the size requirement by the end of the device evaluation will be disqualified. **Device evaluation will take place at the time indicated on the Official Schedule**
11. A robot may expand in size after a match begins, but must not physically separate into pieces and must remain a single centralized robot. Robots violating these restrictions shall lose the match. Screws, nuts, and other robot parts with a total mass of less than 15 grams falling off from a robot shall not cause the loss of match.

12. Robot operation must begin automatically **no less than** five seconds after being started by the user. Robots starting before the five-second mark forfeit the match.
13. Weight may not be added after the robot has been weighed and evaluated by the judges.
14. Robots must be carried or carted to and from the competition ring. Robots may not be driven outside of the competition ring.
15. Double elimination contests will decide the winner of each division.
16. At the beginning of each competition, with the robot deactivated, the Sumo handler(s) will position their Sumo one foot apart as instructed by the judges. Four start configurations will be possible:

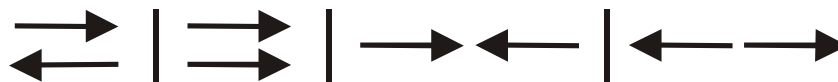

17. At the command of the judge/facilitator, the handler(s) will activate their robot.
18. **All High School and Post-Secondary division robots must have a visible RED latching emergency stop button on top of the robot in case of a malfunction.**
19. When one robot causes **any part** of their opponent to go past the outer white line, that robot is declared the winner of that engagement. To be a loss the robot must have been pushed out by the opposing robot. Driving beyond the outer white line while not under direct contact with an opponent does not constitute a “win” and is declared a “fault”.
20. If a fault is declared, the robots are positioned in the same starting position, and the contest begins anew.
21. If a robot causes three faults in a row, the other robot is declared the winner of the match.
22. If both Sumos leave the ring at the same time, a "no-contest" is declared, and the two Sumos are repositioned, and the contest begins anew.
23. If, after one minute, no winner is declared, the contest is determined to be a “draw,” and the two Sumos are randomly repositioned in one of the possible start configurations, and the contest begins anew. If three encounters in a row end in a “draw”, the judges shall declare a winner based on action observed within the ring and on the design of the selected Sumo robot.
24. All Sumo Robot matches will be in a “best of three” format.
25. A pit area, with access to 110-volt standard outlet, will be provided.
26. Teams must bring documentation of their design process and the iterations that have taken place during the current school year. (i.e., Engineers Notebook or Portfolio)
27. At the conclusion of each match the winning robot must be weighed and measured to ensure that legal size limits have been maintained. Failure to pass this verification will result in a forfeiture of the match.
28. Decisions of the judges are final and binding.



Example
Emergency Stop
(see rule 16)

Sumo Ring Details

Isometric View of the Sumo Competition Ring

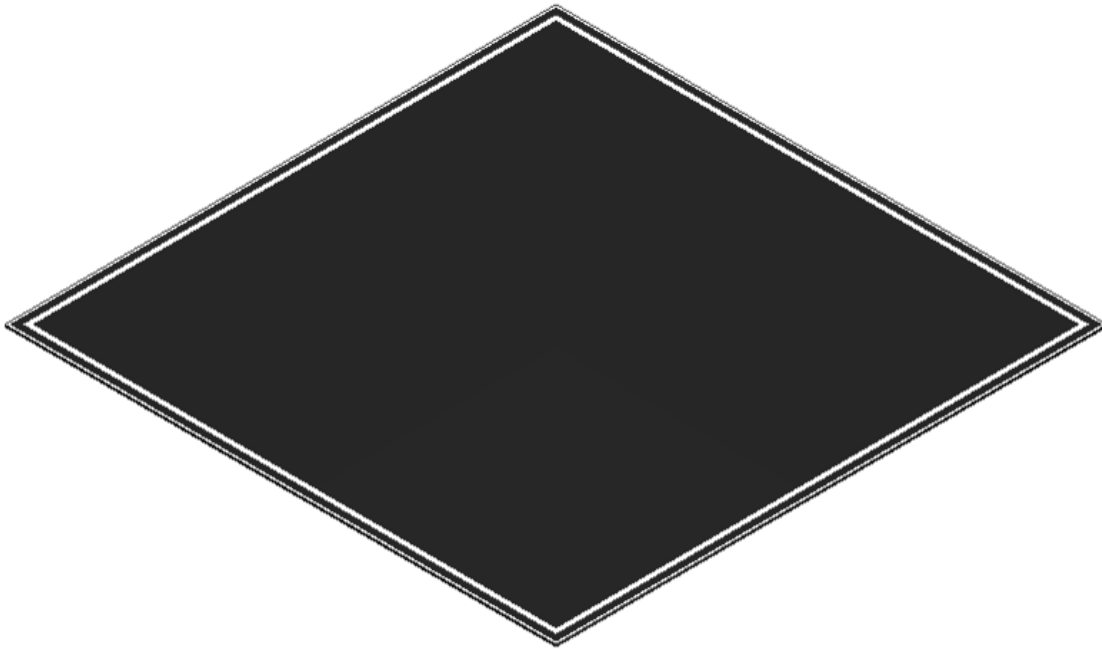

Close-up detail of the lines with dimensions

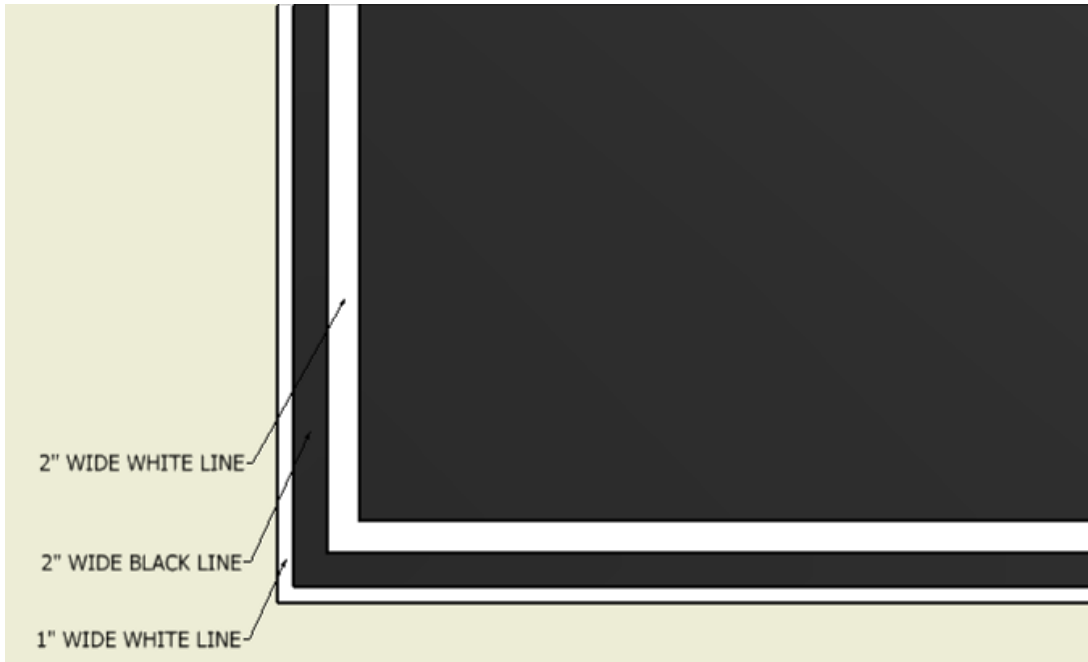

Pre-Competition Device Evaluation/ Interviews Sumo Robot

EVENT: Sumo Robot

LEVEL: _____ Middle School(15 lbs) _____ High School(20 lbs) _____ Post Secondary(20 lbs)

SCHOOL: _____

CAPTAIN: _____

Documentation Inspected (ie. Engineers Notebook or Portfolio) Yes: _____ **No:** _____

Criteria

Sumo Weight

Weight Size Requirements
Middle School ≤ 15 lbs
High School / Post Secondary ≤ 20 lbs

Weight = _____ lbs

Sumo Size

Size Requirements
Middle School = 20" x 20" x 20"
High School = 20" x 20" x 20"
Post-Secondary = 20" x 20" x 20"

Check if the requirement has been met.

Mobility

Walking robots have no rolling elements in contact with the floor and no continuous rolling or cam-operated motion in contact with the floor, either directly or via a linkage.

Walking _____

OR

Shuffling (rotational cam-operated legs)

Shuffling _____

Safety

RED latching emergency stop button on **top** of the robot

Check if the requirement has been met.

Five Second Delayed Start Tested

Check if the requirement has been met.

Entries not meeting any of the above criteria must be brought into compliance before being allowed to compete.

Judge's Comments:

Judge's Signature: _____