

Valtek[®] Valdisk[™]
High-Performance Butterfly
Control Valve

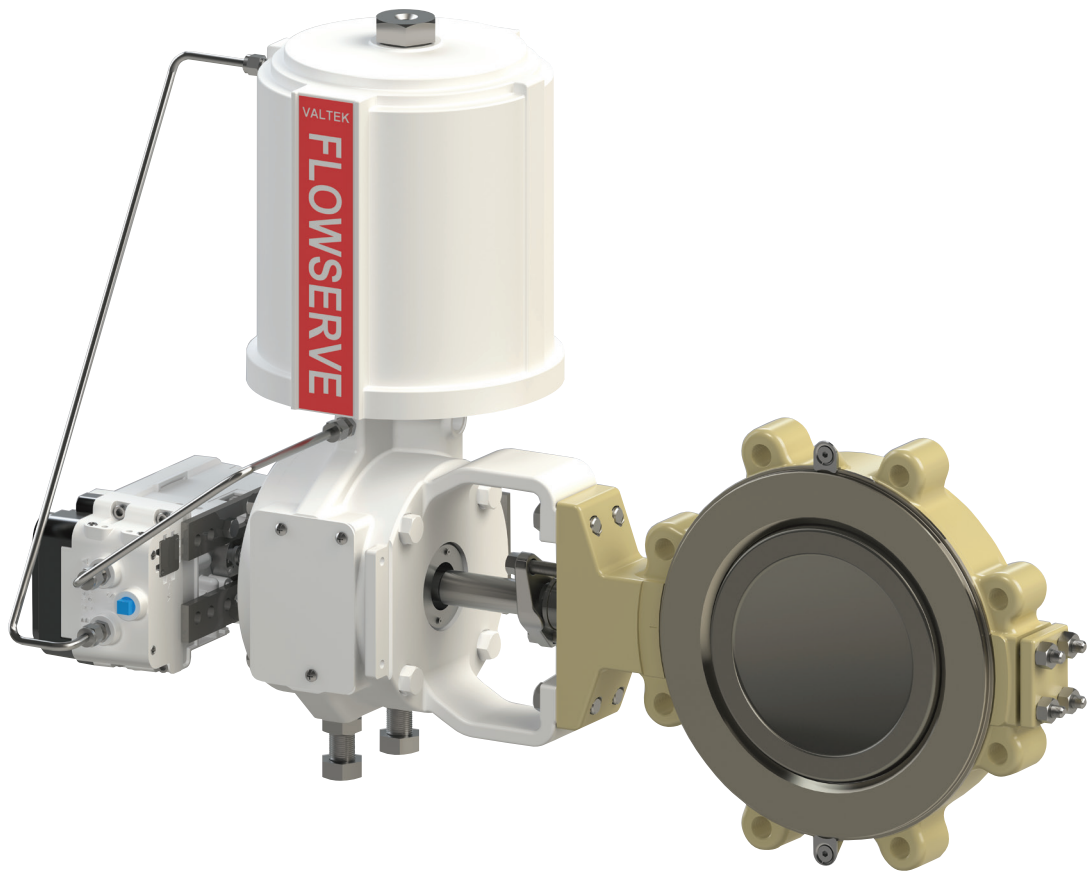

Valtek Valdisk butterfly control valve

Flowserve has an unrivaled combination of technical expertise and practical experience to help you solve the toughest fluid motion control challenges. We help maximize your systems' efficiency and uptime by applying flow-specific technologies and advanced aftermarket capabilities, all supported by a vast team of technical resources.

Industry-leading throttling performance

The Valtek Valdisk valve is a high-performance butterfly control valve. Its double-offset shaft provides eccentric-cammed disc rotation to lift it out of the seat, thus immediately eliminating seat friction, to improve throttling control and reduce seat wear. A one-piece splined shaft connected to a clamped actuator lever provides excellent throttling control. Its soft seating arrangement is designed for bubble-tight shutoff while maintaining low breakout torque.

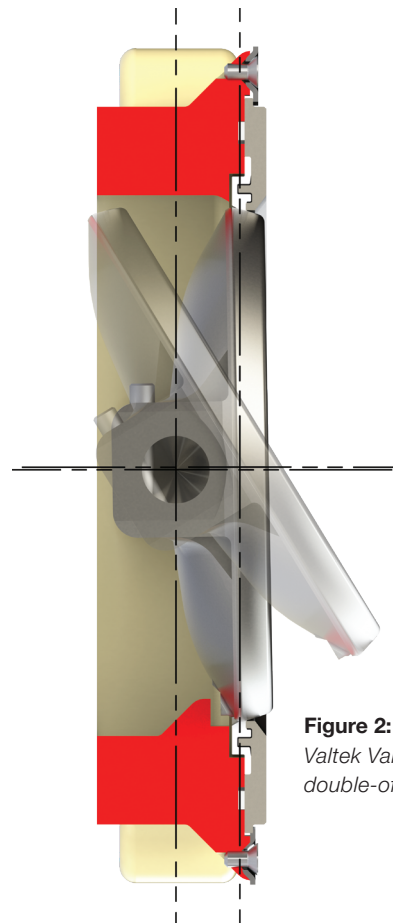

Figure 2: Side view of Valtek Valdisk valve showing double-offset butterfly disc

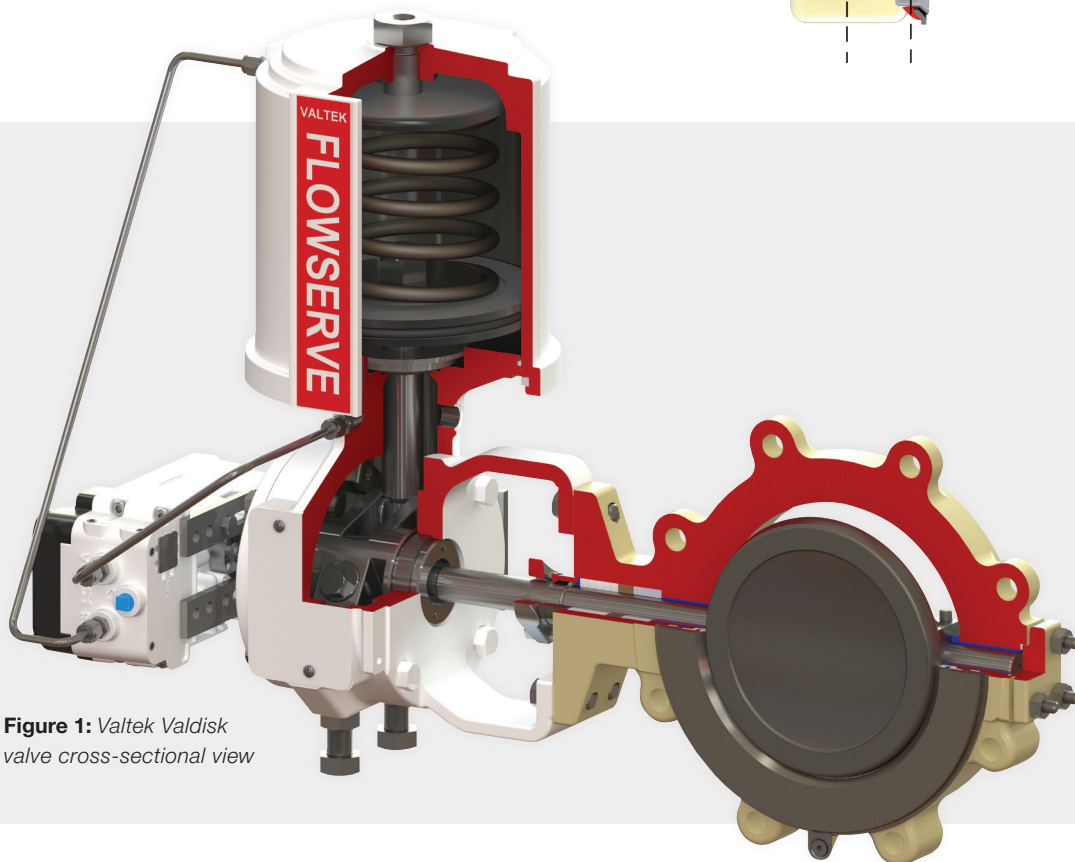

Figure 1: Valtek Valdisk valve cross-sectional view

Table 1: Features and advantages

Features	Advantages
Eccentric-cammed disc	The disc rotates out of seat immediately, eliminating seat friction, to improve throttling control and reduce seat wear.
Splined shaft end	A one-piece, splined shaft end, combined with actuator lever clamp, eliminates lost motion between shaft and actuator to improve throttling control. ⁽¹⁾
Pinned shaft to disc	Tapered shaft to disc pins provide tight connections for excellent control without requiring the shaft to be drilled. ⁽¹⁾
Contoured disc	Inherently linear flow characteristic provides good control over the entire flow range.
Excellent shut-off	Soft seat (Class VI) and metal seat (Class IV) provide reliable long-life, shut-off capability.
Multiple packing options	Packing provides low emissions for a variety of applications, complying with industry standards.
Flow capacity	High flow capacity exceeds that of typical globe valves.
Bolted seat retainer	An uninterrupted gasket surface allows for a wide variety of gasketing.
Bolted shaft flange	Robust design provides safety and eases maintenance.
Shaft retention	Anti-blowout protection provides safety compliance to ASME B16.34 and API 609.
Position indication	Marked for easy visual indication of disc position.
Disc stop in body	The disc stop prevents damage to seat due to over-stroking.
Cylinder actuator	High thrust and stiffness enable precision throttling with air pressure up to 150 psi (10.3 bar).

(1) For sizes up to NPS 16.

Table 2: Specifications

Options	ASME	DIN
Sizes	NPS 2 to 60	DIN 80 to 600
Pressure class	ASME Class 150 to 600	PN 10 to 40
End connection	ASME 16.5 and ASME B16.47	EN 1092-1
Body material	WCC, CF8M; alloys upon request	1.0619, 1.4408; alloys upon request
Face-to-face	API 609 and MSS SP-68; Valtek standard for larger sizes	EN 558 series 20/16
Body style	Lug, wafer (flange-less), double-flanged	Lug, wafer
Packing	PTFE V-ring, braided PTFE, graphite braid, SureGuard™ XT, SafeGuard™	
Packing type	Single, twin, vacuum, live-loaded, fire-safe	
Fire safety	API 607, ISO 10497	
Fugitive emissions	ISO 15848-1	
Temperature	-196°C to 427°C (-320°F to 800°F)	
Shut-off	ANSI/FCI 70-2: Class IV (metal seat) and VI (soft seat)	

Design standards

ASME (B16.34, B16.10, B16.25), API 609, PED, DIN, CRN, ISO, NACE, EN

Test standards

ASME B16.34, ANSI/FCI 70-2

Certifications/approvals

ISO 9001, PED, CRN, TRCU, SIL

Parts list and materials of construction

Figure 3: Exploded view and parts list

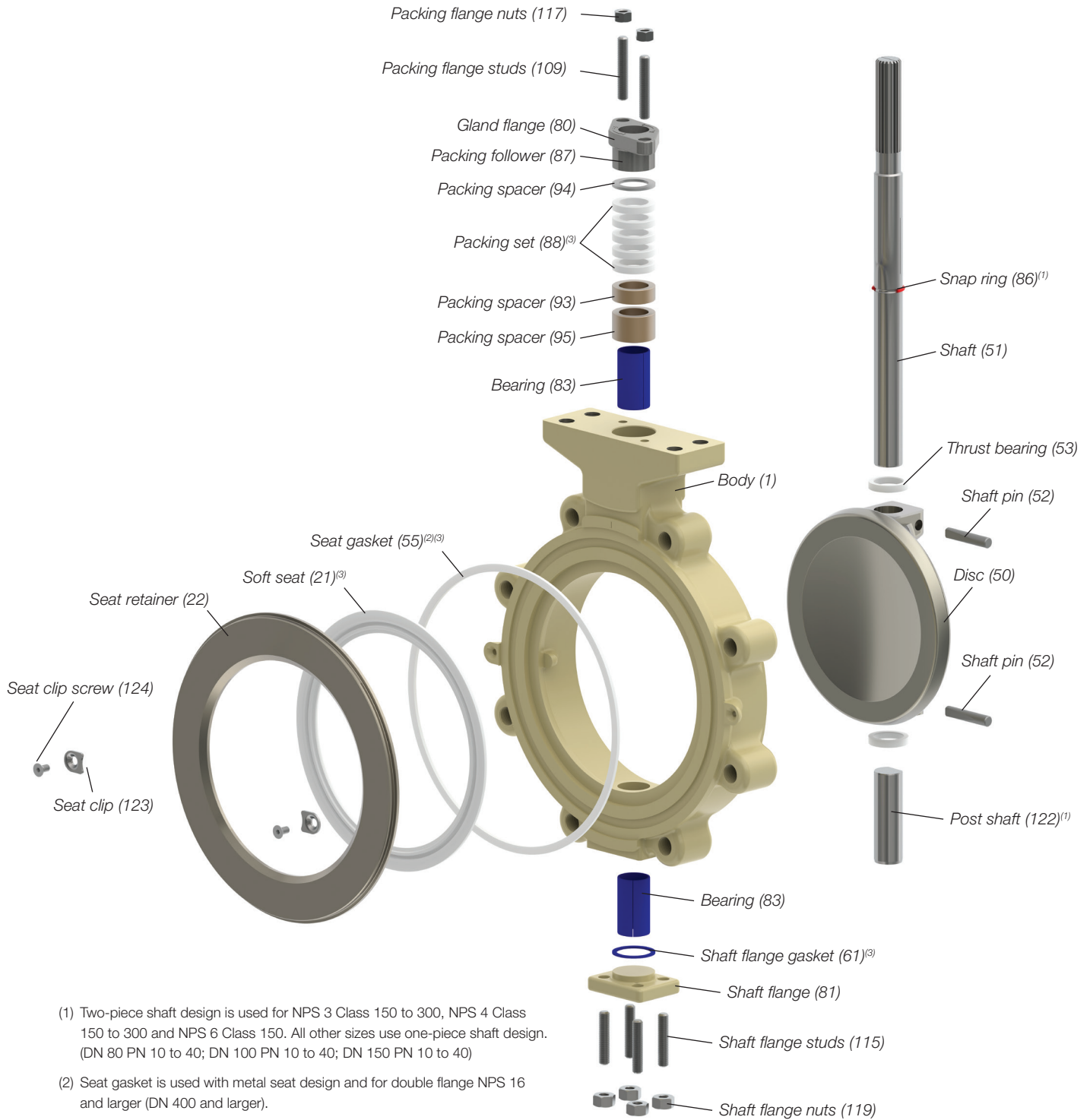

(1) Two-piece shaft design is used for NPS 3 Class 150 to 300, NPS 4 Class 150 to 300 and NPS 6 Class 150. All other sizes use one-piece shaft design. (DN 80 PN 10 to 40; DN 100 PN 10 to 40; DN 150 PN 10 to 40)

(2) Seat gasket is used with metal seat design and for double flange NPS 16 and larger (DN 400 and larger).

(3) Recommended spare parts.

Table 3: Materials of construction

Item	Part	Material	Temperature Range ⁽¹⁾	
			°C	°F
1/50	Body/disc	WCC carbon steel	-29 to 427	-20 to 800
		1.0619	-29 to 427	-20 to 800
		CF8M stainless steel	-254 to 454	-425 to 850
		1.4408	-254 to 454	-425 to 850
		WC9 chrome moly	-29 to 593	-20 to 1,100
		LCC carbon steel	-46 to 343	-50 to 650
		Monel®	-29 to 482	-20 to 900
51/52/122	Shaft/pins/post shaft	Hastelloy C®	-198 to 371	-325 to 700
		17-4 PH H1025	-40 to 427	-40 to 800
		Nitronic 50®	-254 to 538	-425 to 1,000
		Inconel 718®	-253 to 649	-423 to 1,200
		Monel K-500®	-253 to 371	-423 to 700
83	Bearings	Hastelloy C	-198 to 538	-325 to 1,000
		316/PTFE/Kevlar	-101 to 232	-150 to 450
		Inconel 625®/PTFE/Kevlar	-101 to 232	-150 to 450
		Monel/PTFE/Kevlar	-101 to 232	-150 to 450
		Ultimet®	-254 to 427	-425 to 800
21	Soft seat	Alloy 6	-254 to 538	-425 to 1,100
		PTFE	-73 to 177	-100 to 350
		Glass-filled PTFE	-73 to 232	-100 to 450
		UHMWPE	-101 to 85	-150 to 185
		PCTFE	-198 to 149	-325 to 300
55	Seat gasket ⁽³⁾	PEEK™	-73 to 260	-100 to 500
		PTFE	-73 to 177	-100 to 350
		Glass-filled PTFE	-73 to 232	-100 to 450
		UHMWPE	-101 to 85	-150 to 185
		PCTFE	-198 to 149	-325 to 300
20/22	Metal seat/seat retainer	PEEK™	-73 to 260	-100 to 500
		Spiral graphite	-51 to 538	-60 to 1,000
		316 stainless steel	-268 to 316	-450 to 600
		316 stainless steel with Alloy 6	-268 to 649	-450 to 1,200
		Inconel 625	-198 to 649	-325 to 1,200
88	Packing set ⁽²⁾⁽³⁾	Monel K-500	-268 to 316	-450 to 600
		PTFE V-Ring or braid	-73 to 204	-100 to 400
		PTFE/Glass V-Ring	-73 to 260	-100 to 500
		LATTYflon 3265 LM	-73 to 204	-100 to 400
		SafeGuard	-51 to 232	-60 to 450
		SureGuard XT	-29 to 288	-20 to 550
		Graphite braid or rib-braid	-51 to 538	-60 to 1,000
117/119	Packing and shaft flange nuts	Carbon braid	-51 to 427	-60 to 800
		Carbon steel	-29 to 427	-20 to 800
109/115	Packing and shaft flange studs	Stainless steel	-254 to 454	-425 to 850
		Carbon steel	-29 to 427	-20 to 800
80	Gland flange	Stainless steel	-254 to 454	-425 to 850
		WCC carbon steel	-29 to 427	-20 to 800
81	Shaft flange	CF8M stainless steel	-254 to 454	-425 to 850
		WCC carbon steel	-29 to 427	-20 to 800
61	Shaft flange gasket	CF8M stainless steel	-254 to 454	-425 to 850
53	Thrust bearing	Graphite	-51 to 538	-60 to 1,000
93/94/95	Packing spacer	316 stainless steel with nitrided surface	-254 to 538	-425 to 1,000
87	Packing follower	Same as body		
123/124	Seat clip and screw	316 stainless steel	N/A	N/A
86	Snap ring	316 stainless steel	N/A	N/A

(1) Temperature of service fluid.

(2) Temperature range is extended by 93°C (200°F) in both directions when body extension is used.

(3) Temperature limited to 427°C (800°F) in oxidizing services.

® Hastelloy is a registered trademark of Haynes International.

® Inconel is a registered trademark of the International Nickel Co., Inc.

® Monel is a registered trademark of International Nickel Co.

® Nitronic is a registered trademark of AK Steel.

® PEEK is a registered trademark of Victrex plc Corp.

Seats

Soft seat

Unique seat design utilizes the pressure drop across the valve to help energize the soft seat to bubble-tight shutoff in either flow direction, including alternating flow applications. This is done in such a way that seating capacity is increased as differential pressure is increased.

ANSI/FCI 70-2 Class VI shutoff.

Metal seat

Metal seats are used for applications involving temperatures higher than those permitted by the soft seat. The design incorporates a highly flexible lip, which assures full-circle contact between the seat and disc when the valve is closed.

ANSI/FCI 70-2 Class IV shutoff.

Dual fire-safe seat

This seat arrangement incorporates the unique design of the soft seat for tight shutoff plus a metal seat that provides full seat contact in the event a fire damages the soft seat.

ANSI/FCI 70-2 Class VI shutoff.



Figure 4: Soft seating arrangement

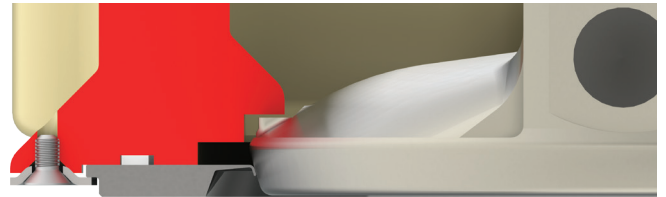

Figure 5: Metal seating arrangement

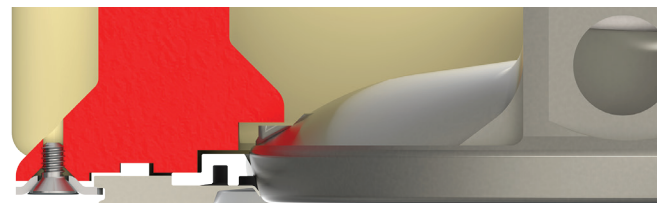

Figure 6: Dual fire-safe seating arrangement

Bonnets

Standard bonnet

Standard Valdisk bodies have the bonnet (packing bore) integral to the body.

Temperature Range: -30°C to 400°C (-22°F to 752°F)¹

Extended bonnet

The extended bonnet is bolted to the Valdisk body, moving the packing further from the fluid temperature to allow more extreme temperatures.

Temperature Range: -100°C to 800°C (-148°F to 1,472°F)¹

Cryogenic bonnet

The cryogenic bonnet is an extension welded to the Valdisk body. When oriented properly in the pipeline, the design of the cryogenic bonnet extension permits stagnated, moderate-temperature gas to form in the bonnet, protecting the packing from colder service fluid.

Temperature Range: -196°C (-320°F)^{1,2}

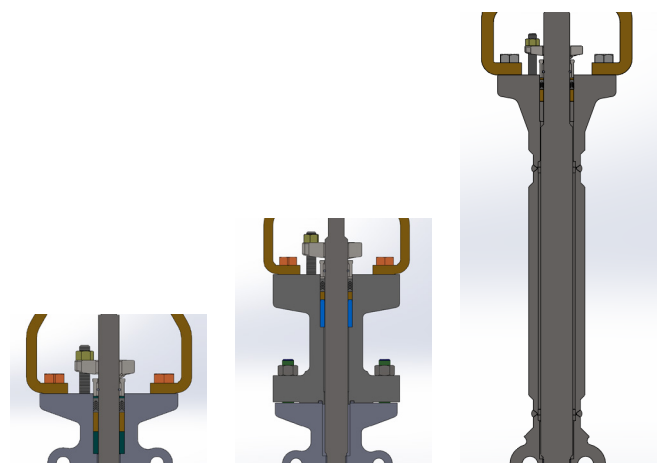

Figure 7: Standard bonnet

Figure 8: Extended bonnet

Figure 9: Cryogenic bonnet

(1) Temperature capabilities are dependent on many factors, including body materials, pressure class and packing selection. See Technical Bulletin for Standard and Environmental Packing Systems for specific temperature limits.

(2) Consult factory for colder temperatures down to -253°C (-423°F).

Table 4: Valdisk Cv – Soft and metal seats

Valve Size		Pressure Class		Soft Seat		Metal Seat/Dual Seat	
				Shaft Upstream	Shaft Downstream	Shaft Upstream	Shaft Downstream
NPS	DN	PN	ANSI	Cv 100	Cv 100	Cv 100	Cv 100
2	-	-	150	71	72	55	55
		-	300	71	72	55	55
		-	600	71	72	55	55
3	80	10/16/25	150	209	208	177	177
		40	300	160	169	135	143
		-	600	160	169	135	143
4	100	10/16/25	150	478	451	448	423
		40	300	373	374	344	345
		-	600	340	341	311	312
6	150	10/16/25	150	1,200	1,119	1,155	1,080
		40	300	991	931	941	885
		-	600	818	798	770	752
8	200	10/16/25	150	2,240	2,290	2,170	2,220
		40	300	1,800	1,690	1,750	1,640
		-	600	1,470	1,430	1,390	1,350
10	250	10/16/25	150	3,830	3,480	3,760	3,410
		40	300	3,210	2,800	3,130	2,730
		-	600	2,270	2,050	2,140	1,940
12	300	10/16/25	150	5,890	5,390	5,800	5,300
		40	300	4,990	4,330	4,900	4,250
		-	600	3,610	3,250	3,460	3,110
14	350	10/16/25	150	7,550	6,840	7,460	6,760
		40	300	5,790	5,040	5,640	4,910
		-	600	3,960	3,580	3,790	3,430
16	400	10/16/25	150	10,660	9,700	10,600	9,600
		40	300	7,630	6,670	7,460	6,520
		-	600	6,330	5,750	6,130	5,570
18	450	10/16/25	150	12,150	12,100	12,100	11,900
		40	300	8,340	7,710	8,190	7,580
		-	600	6,040	5,960	5,880	5,800
20	500	10/16/25	150	17,300	16,200	17,200	16,100
		40	300	11,200	9,750	11,000	9,610
		-	600	8,280	7,720	8,110	7,560
24	600	10/16/25	150	24,100	24,400	23,500	23,700
		40	300	16,300	15,500	16,100	15,300
		-	600	11,400	11,500	11,200	11,300
28	-	-	150	36,100	34,000	36,000	33,800
30	-	-	150	41,500	39,100	41,400	38,900
36	-	-	150	62,300	60,900	62,100	60,700
42	-	-	150	83,200	79,900	83,000	79,700
48	-	-	150	110,000	109,200	109,800	108,900
54	-	-	150	143,000	144,100	142,700	143,800
60	-	-	150	177,800	181,600	177,500	181,300

Chart 1: Valdisk Cv – Soft and metal seats

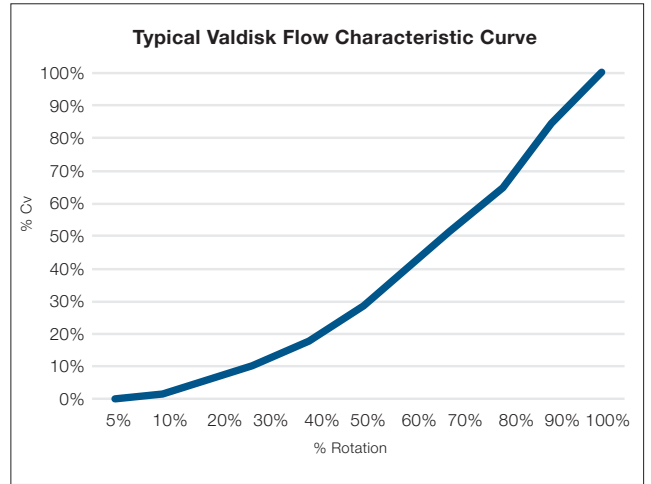

Maximum allowable shutoff pressure drops — Shaft limits

Table 5: Shaft limits, bar

Material	Temp, °C	Maximum Allowable Pressure Drop, bar																				
		NPS 2			NPS 3 (DN 80)			NPS 4 (DN 100)			NPS 6 (DN 150)			NPS 8 (DN 200)			NPS 10 (DN 250)			NPS 12 (DN 300)		
		Class 150	Class 300	Class 600	Class 150 (PN 10/16/25)	Class 300 (PN 40)	Class 600	Class 150 (PN 10/16/25)	Class 300 (PN 40)	Class 600	Class 150 (PN 10/16/25)	Class 300 (PN 40)	Class 600	Class 150 (PN 10/16/25)	Class 300 (PN 40)	Class 600	Class 150 (PN 10/16/25)	Class 300 (PN 40)	Class 600	Class 150 (PN 10/16/25)	Class 300 (PN 40)	Class 600
17-4 PH	-45 to 38	20	52	66	20	52	104	20	52	104	20	52	100	20	52	93	20	52	104	20	48	90
	93	20	49	49	20	52	104	20	52	104	20	52	96	20	52	89	20	52	104	20	46	86
	149	20	29	29	20	52	100	20	52	102	20	52	91	20	52	85	20	52	104	20	44	82
	204	13	13	13	20	51	94	20	52	96	20	52	86	20	52	80	20	48	104	19	41	77
	260	12	12	12	20	49	90	20	52	92	20	52	82	20	52	77	20	46	104	18	40	74
	316	11	11	11	20	47	86	20	52	88	20	52	79	20	52	73	20	44	104	17	38	71
	371	11	11	11	20	45	83	20	52	85	20	52	76	20	52	70	20	42	104	17	36	68
Inconel 718	427	11	11	11	20	43	79	20	52	80	20	51	72	20	51	67	19	40	104	16	35	65
	-45 to 38	20	52	66	20	52	104	20	52	104	20	52	101	20	52	94	20	52	104	20	49	91
	93	20	49	49	20	52	104	20	52	104	20	52	101	20	52	93	20	52	104	20	49	91
	149	20	29	29	20	52	104	20	52	104	20	52	99	20	52	92	20	52	104	20	48	90
	204	13	13	13	20	52	104	20	52	104	20	52	98	20	52	91	20	52	104	20	47	89
	260	12	12	12	20	52	104	20	52	104	20	52	97	20	52	90	20	52	104	20	47	88
	316	11	11	11	20	52	104	20	52	104	20	52	96	20	52	90	20	52	104	20	46	87
Nitronic 50	371	11	11	11	20	52	104	20	52	104	20	52	95	20	52	88	20	52	104	20	46	86
	427	11	11	11	20	52	104	20	52	104	20	52	94	20	52	87	20	52	104	20	45	85
	-45 to 38	20	52	66	20	39	54	20	52	87	20	52	78	20	52	73	20	40	104	17	38	70
	93	20	49	49	20	36	49	20	48	80	20	50	71	20	50	66	19	36	104	16	34	64
	149	20	29	29	20	34	47	20	46	75	20	48	67	20	47	63	18	34	104	15	32	61
	204	13	13	13	20	32	44	20	44	72	19	45	64	20	45	59	17	33	104	14	31	58
	260	12	12	12	20	31	42	20	42	69	18	44	61	20	43	57	16	31	104	14	30	55
Monel K-500	316	11	11	11	20	30	41	20	40	66	17	42	59	19	41	55	15	30	100	13	28	53
	371	11	11	11	20	28	39	20	38	63	17	40	56	18	40	52	15	29	96	12	27	51
	427	11	11	11	20	25	34	17	33	55	14	35	49	16	34	45	13	25	83	11	24	44
	-45 to 38	20	52	60	20	29	40	20	47	77	20	49	69	20	49	64	18	34	104	15	33	62
	93	20	49	49	20	28	39	20	46	75	20	48	67	20	47	62	18	33	104	15	32	61
	149	20	29	29	20	28	38	20	45	74	20	47	66	20	46	61	17	32	104	15	32	59
	204	10	10	10	20	27	38	20	44	73	19	46	65	20	46	61	17	32	104	14	31	59
316	N/A	N/A	N/A	20	27	37	20	44	72	19	46	64	20	46	60	17	32	104	14	31	58	
371	N/A	N/A	N/A	20	26	36	20	43	70	19	44	63	20	44	58	16	31	104	14	30	57	

Material	Temp, °C	Maximum Allowable Pressure Drop, bar																					
		NPS 14 (DN 350)			NPS 16 (DN 400)			NPS 18 (DN 450)			NPS 20 (DN 500)			NPS 24 (DN 600)			NPS 28	NPS 30	NPS 36	NPS 42	NPS 48	NPS 54	NPS 60
		Class 150 (PN 10/16/25)	Class 300 (PN 40)	Class 600	Class 150 (PN 10/16/25)	Class 300 (PN 40)	Class 600	Class 150 (PN 10/16/25)	Class 300 (PN 40)	Class 600	Class 150 (PN 10/16/25)	Class 300 (PN 40)	Class 600	Class 150 (PN 10/16/25)	Class 300 (PN 40)	Class 600	Class 150	Class 150	Class 150	Class 150	Class 150	Class 150	Class 150
17-4 PH	-45 to 38	20	52	103	20	66	103	20	52	77	20	52	76	20	52	83	20	20	20	21	20	20	20
	93	20	51	99	20	63	99	20	50	73	19	49	72	20	50	79	20	20	19	20	20	19	19
	149	19	48	94	20	60	94	20	48	70	19	47	69	20	48	76	19	20	18	19	19	18	18
	204	18	45	88	20	56	88	20	45	65	17	44	65	19	45	71	18	19	17	18	18	17	17
	260	17	44	85	20	54	85	20	43	63	17	43	62	18	43	68	17	18	16	17	17	16	17
	316	16	42	81	20	52	81	20	41	60	16	41	60	17	41	65	16	18	16	16	17	16	16
	371	16	40	78	19	50	78	20	40	58	15	39	57	17	40	63	16	17	15	16	16	15	15
Inconel 718	427	15	38	74	18	47	74	20	38	55	15	37	54	16	38	59	15	16	14	15	15	14	15
	-45 to 38	20	52	104	20	52	104	20	52	77	20	52	76	20	52	83	20	20	20	20	20	20	20
	93	20	52	104	20	52	104	20	52	77	20	52	76	20	52	83	20	20	20	20	20	20	20
	149	20	52	103	20	52	102	20	52	76	20	51	75	20	52	82	20	20	20	20	20	20	20
	204	20	52	101	20	52	101	20	51	75	20	51	74	20	51	81	20	20	20	20	20	20	20
	260	20	51	100	20	52	100	20	51	74	20	50	73	20	51	80	20	20	20	20	20	19	20
	316	20	51	100	20	52	99	20	50	74	20	50	73	20	50	80	20	20	20	20	20	19	19
Nitronic 50	371	20	50	98	20	52	98	20	50	73	19	49	72	20	50	79	20	20	20	20	20	19	19
	427	19	50	97	20	52	96	20	49	72	19	48	71	20	49	77	19	20	20	19	20	19	19
	-45 to 38	16	41	81	20	51	77	20	41	60	16	40	59	17	41	65	16	17	18	16	16	15	16
	93	15	38	73	18	47	70	20	37	54	14	37	54	16	37	59	15	16	17	15	15	14	14
	149	14	36	70	17	44	66	19	35	51	14	35	51	15	35	56	14	15	16	14	14	13	14
	204	13	34	66	16	42	63	19	33	49	13	33	48	14	33	53	13	14	15	13	14	12	13
	260	13	33	63	16	40	60	18	32	47	12	32	47	14	32	51	13	14	14	13	13	12	12
Monel K-500	316	12	31	61	15	38	58	17	31	45	12	30	45	13	31	49	12	13	14	12	12	11	12
	371	12	30	58	14	37	56	16	30	43	11	29	43	12	30	47	12	13	13	12	12	11	11
	427	10	26	50	12	32	48	14	26	37	10	25	37	11	26	40	10	11	11	10	10	10	10
	-45 to 38	14	37	71	18	45	67	20	36	53	14	36	52	15	36	57	14	15	13	14	15	14	14
	93	14	36	69	17	44	65	19	35	51	14	35	51	15	35	55	14	15	13	14	14	13	14
	149	14	35	68	17	43	64	19	34	50	13	34	50	15	34	54	14	15	12	14	14	13	13
	204	13	35	67	17	43	63	19	34	50	13	34	49	14	34	54	13	15	12	13	14	13	13
316	13	34	67	16	42	62	19	34	49	13	33	49	14	34	53	13	14	12	13	14	13	13	
371	13	33	65	16	41	61	18	33	48	13	32	48	14	33	52	13	14	12	13	13	12	13	

Table 6: Shaft limits, psi

Material	Temp, °F	Maximum Allowable Pressure Drop, psi																				
		NPS 2			NPS 3 (DN 80)			NPS 4 (DN 100)			NPS 6 (DN 150)			NPS 8 (DN 200)			NPS 10 (DN 250)			NPS 12 (DN 300)		
		Class 150	Class 300	Class 600	Class 150 (PN 10/16/25)	Class 300 (PN 40)	Class 600	Class 150 (PN 10/16/25)	Class 300 (PN 40)	Class 600	Class 150 (PN 10/16/25)	Class 300 (PN 40)	Class 600	Class 150 (PN 10/16/25)	Class 300 (PN 40)	Class 600	Class 150 (PN 10/16/25)	Class 300 (PN 40)	Class 600	Class 150 (PN 10/16/25)	Class 300 (PN 40)	Class 600
17-4 PH	-50 to 100	290	750	954	290	750	1,500	290	750	1,500	290	750	1,450	290	750	1,350	290	750	1,500	290	700	1,310
	200	290	705	705	290	750	1,500	290	750	1,500	290	750	1,386	290	750	1,290	290	750	1,500	290	669	1,252
	300	290	420	420	290	750	1,451	290	750	1,483	290	750	1,323	290	750	1,232	290	742	1,500	290	639	1,195
	400	185	185	185	290	742	1,360	290	750	1,390	290	750	1,240	290	750	1,154	290	695	1,500	274	599	1,120
	500	171	171	171	290	715	1,310	290	750	1,339	290	750	1,194	290	750	1,112	290	670	1,500	264	577	1,079
	600	159	159	159	290	683	1,252	290	750	1,279	290	750	1,141	290	750	1,063	290	640	1,500	252	551	1,031
	700	157	157	157	290	656	1,202	290	748	1,228	290	750	1,096	290	750	1,020	287	615	1,500	242	529	990
800	155	155	155	290	623	1,142	290	711	1,167	290	740	1,041	290	736	969	273	584	1,500	230	503	941	
Inconel 718	-50 to 100	290	750	954	290	750	1,500	290	750	1,500	290	750	1,459	290	750	1,358	290	750	1,500	290	704	1,318
	200	290	705	705	290	750	1,500	290	750	1,500	290	750	1,459	290	750	1,351	290	750	1,500	290	704	1,318
	300	290	420	420	290	750	1,500	290	750	1,500	290	750	1,440	290	750	1,341	290	750	1,500	290	695	1,301
	400	185	185	185	290	750	1,500	290	750	1,500	290	750	1,421	290	750	1,323	290	750	1,500	290	686	1,284
	500	171	171	171	290	750	1,500	290	750	1,500	290	750	1,404	290	750	1,308	290	750	1,500	290	678	1,269
	600	159	159	159	290	750	1,500	290	750	1,500	290	750	1,395	290	750	1,299	290	750	1,500	290	674	1,260
	700	157	157	157	290	750	1,500	290	940	1,500	290	750	1,376	290	750	1,281	290	750	1,500	290	664	1,244
800	155	155	155	290	750	1,500	290	927	1,500	290	750	1,358	290	750	1,264	290	750	1,500	290	655	1,227	
Nitronic 50	-50 to 100	290	750	954	290	569	784	290	750	1,268	290	750	1,131	290	750	1,053	290	579	1,500	250	546	1,022
	200	290	705	705	290	518	714	290	703	1,154	290	732	1,030	290	728	959	270	527	1,500	227	497	930
	300	290	420	420	290	490	675	290	665	1,092	289	692	974	290	689	907	255	499	1,500	215	470	880
	400	185	185	185	290	466	642	290	633	1,038	275	658	927	290	655	863	243	474	1,500	204	447	837
	500	171	171	171	290	447	616	290	607	996	264	631	889	283	628	828	233	455	1,500	196	429	803
	600	159	159	159	290	428	590	290	581	954	253	605	851	271	602	793	223	436	1,443	188	411	769
	700	157	157	157	290	411	567	290	558	916	243	581	817	260	578	761	214	419	1,386	180	395	739
800	155	155	155	290	355	490	253	482	792	210	502	706	225	499	658	185	362	1,197	156	341	638	
Monel K-500	-50 to 100	290	750	865	290	420	578	290	683	1,121	290	711	1,001	290	707	932	262	489	1,500	221	483	904
	200	290	705	705	290	408	561	290	663	1,089	288	690	972	290	687	905	255	475	1,500	214	469	878
	300	290	420	420	290	400	551	290	651	1,068	283	677	953	290	674	888	250	466	1,500	210	460	861
	400	150	150	150	290	397	546	290	645	1,059	281	671	945	290	668	880	248	462	1,500	209	456	854
	500	50	50	50	290	392	540	290	638	1,048	277	664	935	290	661	870	245	457	1,500	206	451	845
	600	N/A	N/A	N/A	290	389	535	290	633	1,038	275	658	927	290	655	863	243	453	1,500	204	447	837
	700	N/A	N/A	N/A	290	381	525	290	620	1,018	270	645	908	290	642	845	238	444	1,500	200	438	820

Material	Temp, °F	Maximum Allowable Pressure Drop, psi																					
		NPS 14 (DN 350)			NPS 16 (DN 400)			NPS 18 (DN 450)			NPS 20 (DN 500)			NPS 24 (DN 600)			NPS 28	NPS 30	NPS 36	NPS 42	NPS 48	NPS 54	NPS 60
		Class 150 (PN 10/16/25)	Class 300 (PN 40)	Class 600	Class 150 (PN 10/16/25)	Class 300 (PN 40)	Class 600	Class 150 (PN 10/16/25)	Class 300 (PN 40)	Class 600	Class 150 (PN 10/16/25)	Class 300 (PN 40)	Class 600	Class 150 (PN 10/16/25)	Class 300 (PN 40)	Class 600	Class 150	Class 150	Class 150	Class 150	Class 150	Class 150	Class 150
17-4 PH	-50 to 100	290	750	1,500	290	750	1,500	290	750	1,110	290	750	1,100	290	750	1,200	290	290	290	290	290	290	290
	200	287	736	1,433	290	750	1,433	290	726	1,061	282	717	1,051	290	726	1,147	286	290	277	285	290	277	280
	300	274	703	1,369	290	750	1,369	290	694	1,013	269	684	1,004	290	694	1,095	273	290	265	272	281	265	267
	400	257	658	1,283	290	750	1,283	290	650	949	252	641	941	274	650	1,026	256	278	248	255	263	248	251
	500	247	634	1,236	290	750	1,236	290	626	914	243	618	906	264	626	989	246	268	239	245	254	239	241
	600	236	606	1,181	290	748	1,181	290	598	874	232	590	866	252	598	945	235	256	228	235	242	228	231
	700	227	582	1,134	280	718	1,134	290	574	839	223	567	831	242	574	907	226	246	219	225	233	219	221
800	215	553	1,077	266	682	1,077	290	546	797	212	539	790	230	546	862	215	233	208	214	221	208	210	
Inconel 718	-50 to 100	290	750	1,500	290	750	1,500	290	750	1,117	290	750	1,107	290	750	1,207	290	290	290	290	290	290	290
	200	290	750	1,500	290	750	1,500	290	750	1,117	290	750	1,107	290	750	1,207	290	290	290	290	290	290	290
	300	290	750	1,490	290	750	1,483	290	750	1,102	290	745	1,092	290	750	1,192	290	290	290	290	290	288	290
	400	290	750	1,470	290	750	1,463	290	745	1,088	289	735	1,078	290	745	1,176	290	290	290	290	290	285	287
	500	290	746	1,453	290	750	1,446	290	736	1,075	286	726	1,065	290	736	1,162	290	290	290	289	290	281	284
	600	289	741	1,443	290	750	1,437	290	731	1,068	284	722	1,058	308	731	1,155	288	290	290	287	290	279	282
	700	285	731	1,424	290	750	1,417	290	721	1,054	280	712	1,044	304	721	1,139	284	290	290	283	290	276	278
800	281	721	1,405	290	750	1,398	290	712	1,039	276	702	1,030	300	712	1,124	280	290	290	279	289	272	275	
Nitronic 50	-50 to 100	234	601	1,170	289	741	1,114	290	593	866	230	585	858	250	593	936	232	252	265	232	239	221	228
	200	213	547	1,065	263	675	1,014	290	540	788	210	533	781	227	540	852	211	229	241	211	218	201	208
	300	202	517	1,008	249	638	960	282	511	746	198	504	739	215	511	806	200	217	228	200	206	190	196
	400	192	492	959	236	607	913	268	486	709	189	479	703	204	486	767	190	206	217	190	196	181	187
	500	184	472	920	227	582	876	257	466	680	181	460	674	196	466	736	182	198	208	182	188	174	179
	600	176	452	881	217	558	838	247	446	652	173	440	646	188	446	704	175	190	199	175	180	166	172
	700	169	434	846	209	536	805	237	428	626	166	423	620	180	428	677	168	182	192	168	173	160	165
800	146	375	731	180	463	696	205	370	541	144	365	536	156	370	585	145	157	166	145	149	138	142	
Monel K-500	-50 to 100	207	531	1,035	255	656	967	290	524	766	204	518	759	221	524	828	206	224	190	206	213	196	203
	200	201	516	1,00																			

Maximum allowable shutoff pressure drops — Bearing limits

Table 7: Bearing limits, bar

Material	Temp, °C	Maximum Allowable Pressure Drop, bar									
		Valve Size									
		NPS 2	NPS 3 (DN 80)	NPS 4 (DN 100)	NPS 6 (DN 150)	NPS 8 (DN 200)	NPS 10 (DN 250)	NPS 12 (DN 300)	NPS 14 (DN 350)	NPS 16 (DN 400)	NPS 18 (DN 450)
316/PTFE/Kevlar	-45 to 93	103	103	103	103	97	103	103	97	97	90
	149	97	97	97	97	90	97	97	90	90	83
	204	83	83	83	83	76	83	83	76	76	69
	260	34	34	34	34	28	34	34	28	28	24
	316 to 427	-	-	-	-	-	-	-	-	-	-
Ultimet	-45 to 93	76	76	76	76	76	76	76	76	76	76
	149	69	69	69	69	69	69	69	69	69	69
	204	62	62	62	62	62	62	62	62	62	62
	260	59	59	59	59	59	59	59	59	59	59
	316	55	55	55	55	55	55	55	55	55	55
	371	52	52	52	52	52	52	52	52	52	52
Alloy 6	-45 to 149	103	103	103	103	103	103	103	103	103	103
	204	97	97	97	97	97	97	97	97	97	97
	260	90	90	90	90	90	90	90	90	90	90
	316	83	83	83	83	83	83	83	83	83	83
	371	76	76	76	76	76	76	76	76	76	76
	427	69	69	69	69	69	69	69	69	69	69

Material	Temp, °C	Maximum Allowable Pressure Drop, bar								
		Valve Size								
		NPS 20 (DN 500)	NPS 24 (DN 600)	NPS 28	NPS 30	NPS 36	NPS 42	NPS 48	NPS 54	NPS 60
316/PTFE/Kevlar	-45 to 93	90	83	20	20	20	20	20	20	20
	149	83	76	20	20	20	20	20	20	20
	204	69	62	14	14	14	14	14	14	14
	260	24	21	10	10	10	10	10	10	10
	316 to 427	-	-	-	-	-	-	-	-	-
Ultimet	-45 to 93	76	76	76	76	76	76	76	76	76
	149	69	69	69	69	69	69	69	69	69
	204	62	62	62	62	62	62	62	62	62
	260	59	59	59	59	59	59	59	59	59
	316	55	55	55	55	55	55	55	55	55
	371	52	52	52	52	52	52	52	52	52
Alloy 6	-45 to 149	103	103	103	103	103	103	103	103	103
	204	97	97	97	97	97	97	97	97	97
	260	90	90	90	90	90	90	90	90	90
	316	83	83	83	83	83	83	83	83	83
	371	76	76	76	76	76	76	76	76	76
	427	69	69	69	69	69	69	69	69	69

Table 8: Bearing limits, psi

Material	Temp, °F	Maximum Allowable Pressure Drop, psi									
		Valve Size									
		NPS 2	NPS 3 (DN 80)	NPS 4 (DN 100)	NPS 6 (DN 150)	NPS 8 (DN 200)	NPS 10 (DN 250)	NPS 12 (DN 300)	NPS 14 (DN 350)	NPS 16 (DN 400)	NPS 18 (DN 450)
316/PTFE/Kevlar	-50 to 200	1,500	1,500	1,500	1,500	1,400	1,500	1,500	1,400	1,400	1,300
	300	1,400	1,400	1,400	1,400	1,300	1,400	1,400	1,300	1,300	1,200
	400	1,200	1,200	1,200	1,200	1,100	1,200	1,200	1,100	1,100	1,000
	500	500	500	500	500	400	500	500	400	400	350
	600 to 800	-	-	-	-	-	-	-	-	-	-
Ultimet	-50 to 200	1,100	1,100	1,100	1,100	1,100	1,100	1,100	1,100	1,100	1,100
	300	1,000	1,000	1,000	1,000	1,000	1,000	1,000	1,000	1,000	1,000
	400	900	900	900	900	900	900	900	900	900	900
	500	850	850	850	850	850	850	850	850	850	850
	600	800	800	800	800	800	800	800	800	800	800
	700	750	750	750	750	750	750	750	750	750	750
Alloy 6	-50 to 300	1,500	1,500	1,500	1,500	1,500	1,500	1,500	1,500	1,500	1,500
	400	1,400	1,400	1,400	1,400	1,400	1,400	1,400	1,400	1,400	1,400
	500	1,300	1,300	1,300	1,300	1,300	1,300	1,300	1,300	1,300	1,300
	600	1,200	1,200	1,200	1,200	1,200	1,200	1,200	1,200	1,200	1,200
	700	1,100	1,100	1,100	1,100	1,100	1,100	1,100	1,100	1,100	1,100
	800	1,000	1,000	1,000	1,000	1,000	1,000	1,000	1,000	1,000	1,000

Material	Temp, °F	Maximum Allowable Pressure Drop, psi								
		Valve Size								
		NPS 20 (DN 500)	NPS 24 (DN 600)	NPS 28	NPS 30	NPS 36	NPS 42	NPS 48	NPS 54	NPS 60
316/PTFE/Kevlar	-50 to 200	1,300	1,200	290	290	290	290	290	290	290
	300	1,200	1,100	290	290	290	290	290	290	290
	400	1,000	900	200	200	200	200	200	200	200
	500	350	300	150	150	150	150	150	150	150
	600 to 800	-	-	-	-	-	-	-	-	-
Ultimet	-50 to 200	1,100	1,100	1,100	1,100	1,100	1,100	1,100	1,100	1,100
	300	1,000	1,000	1,000	1,000	1,000	1,000	1,000	1,000	1,000
	400	900	900	900	900	900	900	900	900	900
	500	850	850	850	850	850	850	850	850	850
	600	800	800	800	800	800	800	800	800	800
	700	750	750	750	750	750	750	750	750	750
Alloy 6	-50 to 300	1,500	1,500	1,500	1,500	1,500	1,500	1,500	1,500	1,500
	400	1,400	1,400	1,400	1,400	1,400	1,400	1,400	1,400	1,400
	500	1,300	1,300	1,300	1,300	1,300	1,300	1,300	1,300	1,300
	600	1,200	1,200	1,200	1,200	1,200	1,200	1,200	1,200	1,200
	700	1,100	1,100	1,100	1,100	1,100	1,100	1,100	1,100	1,100
	800	1,000	1,000	1,000	1,000	1,000	1,000	1,000	1,000	1,000

Maximum allowable shutoff pressure drops — Seat Limits

Table 9: Seat limits — NPS 2 to 12 (DN 80 to 300), bar and psi

Material	Temperature		Maximum Allowable Pressure Drop	
	°C	°F	bar	psi
PTFE	-45 to 38	-50 to 100	62	900
	93	200	32	470
	149	300	13	190
	177	350	5	70
	260 to 427	500 to 800	-	-
Glass-filled PTFE	-45 to 38	-50 to 100	72	1,050
	93	200	38	550
	149	300	15	200
	204	400	8	110
	232	450	3	50
	316 to 427	600 to 800	-	-
UHMWPE	-73 to 38	-100 to 100	76	1,100
	93	200	31	450
	149 to 427	300 to 800	-	-
316 SS/316L SS/ 304 SS (with or without Alloy 6)	-45 to 38	-50 to 100	24.1/65.5	350/950
	93	200	24.1/65.5	350/950
	149	300	22.8/59.7	330/865
	204	400	21.4/53.1	310/770
	260	500	19.3/47.6	280/690
	316	600	16.6/41.4	240/600
	371	700	15.2/36.6	220/530
	427	800	13.1/31.7	190/460

Table 10: Seat limits – NPS 14 to 60 (DN 350 to 600), bar and psi

Material	Temperature		Maximum Allowable Pressure Drop	
	°C	°F	bar	psi
PTFE	-45 to 38	-50 to 100	62	900
	93	200	32	470
	149	300	13	190
	177	350	5	70
	260 to 427	500 to 800	-	-
Glass-filled PTFE	-45 to 38	-50 to 100	72	1,050
	93	200	38	550
	149	300	14	200
	204	400	8	110
	232	450	3	50
	316 to 427	600 to 800	-	-
UHMWPE	-73 to 38	-100 to 100	76	1,100
	93	200	31	450
	149 to 427	300 to 800	-	-
316 SS, 316L SS, 304 SS (with or without Alloy 6)	-45 to 38	-50 to 100	24.1/65.5	350/950
	93	200	24.1/65.5	350/950
	149	300	22.8/59.7	330/865
	204	400	21.4/53.1	310/770
	260	500	19.3/47.6	280/690
	316	600	16.6/41.4	240/600
	371	700	15.2/36.6	220/530
	427	800	13.1/31.7	190/460

Dimensions

Lug style, NPS 3 to 16 (DN 80 to 400), Class 150 to 600 (PN 10 to 40)

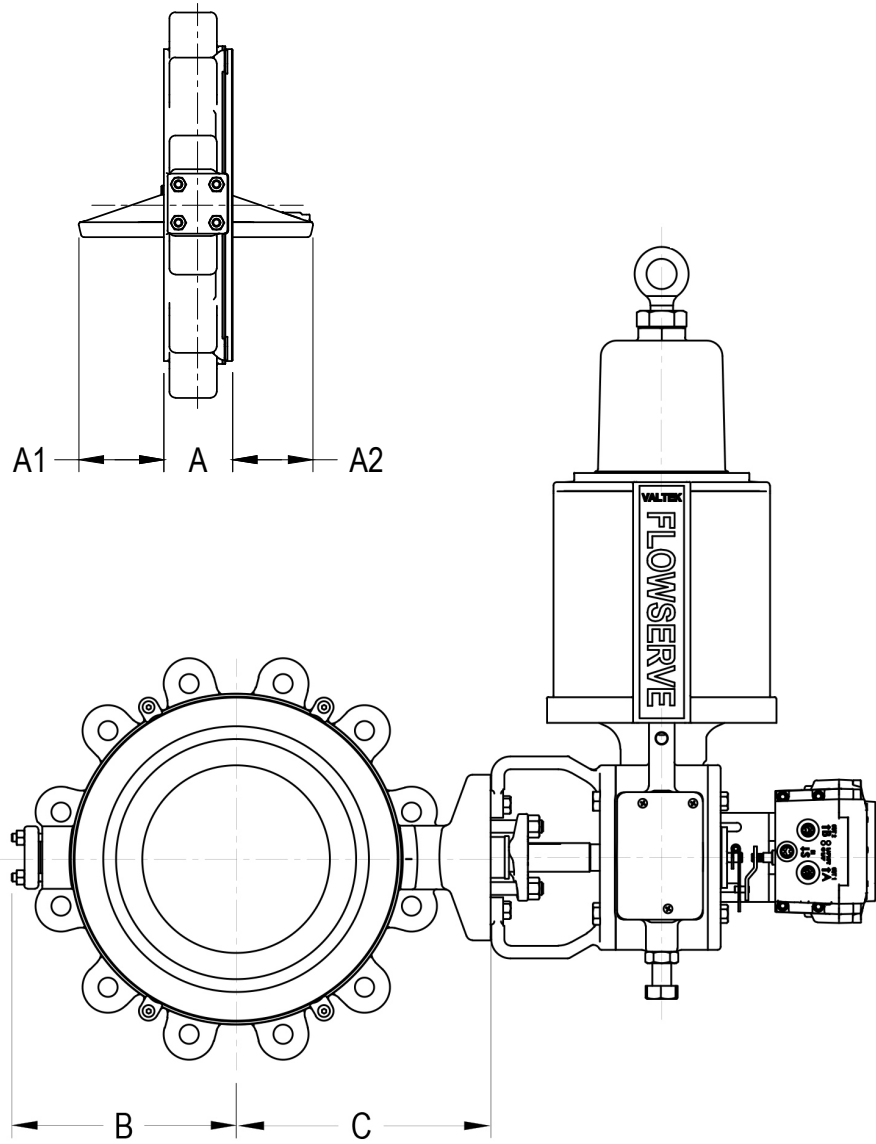

Table 11: Dimensions⁽¹⁾ – Lug style, NPS 3 to 16 (DN 80 to 400), Class 150 to 600 (PN 10 to 40)

Metric

Valve Size	ASME, mm						Valve Size	DIN, mm						Weight ⁽²⁾ , kg
	Class	A	A1	A2	B	C		Pressure Rating	A	A1	A2	B	C	
3	150	48	20	10	99	124	DN 80	PN 10/16/25	46	22	11	123	124	24
	300	48	20	10	124	124		PN 40	64	9	11	124	125	26
	600	54	16	8	124	124		-	-	-	-	-	-	27
4	150	54	28	23	128	141	DN 100	PN 10/16/25	52	30	23	126	141	29
	300	54	28	19	145	161		PN 40	64	18	19	142	161	32
	600	64	24	13	160	168		-	-	-	-	-	-	50
6	150	57	49	42	142	186	DN 150	PN 10/16/25	56	50	42	146	186	49
	300	59	49	40	181	192		PN 40	76	39	33	188	192	57
	600	78	37	30	211	197		-	-	-	-	-	-	72
8	150	64	70	60	185	223	DN 200	PN 10/16/25	60	74	60	200	223	61
	300	73	61	59	221	229		PN 40	89	45	59	220	229	73
	600	102	45	45	255	233		-	-	-	-	-	-	137
10	150	71	88	83	224	254	DN 250	PN 10/16/25	68	91	84	223	253	76
	300	83	82	79	250	266		PN 40	114	56	74	256	266	138
	600	117	69	50	311	282		-	-	-	-	-	-	198
12	150	81	113	105	271	292	DN 300	PN 10/16/25	78	115	104	280	292	101
	300	92	100	98	295	302		PN 40	114	85	92	295	302	167
	600	140	82	65	342	321		-	-	-	-	-	-	249
14	150	92	115	118	295	305	DN 350	PN 10/16/25	79	126	119	319	305	157
	300	117	108	95	340	325		PN 40	127	103	91	340	325	257
	600	155	82	67	372	356		-	-	-	-	-	-	341
16	150	102	138	138	329	353	DN 400	PN 10/16/25	102	137	138	344	353	196
	300	133	124	108	370	397		PN 40	140	119	107	374	397	316
	600	178	97	87	406	404		-	-	-	-	-	-	441

U.S.

Valve Size	ASME, in.						Weight ⁽²⁾ , lb
	Class	A	A1	A2	B	C	
3	150	1.88	0.8	0.4	3.9	4.9	54
	300	1.88	0.8	0.4	4.9	4.9	58
	600	2.12	0.6	0.3	4.9	4.9	60
4	150	2.12	1.1	0.9	5.0	5.6	63
	300	2.12	1.1	0.8	5.7	6.3	70
	600	2.50	0.9	0.5	6.3	6.6	110
6	150	2.25	1.9	1.7	5.6	7.3	109
	300	2.31	1.9	1.6	7.1	7.6	125
	600	3.06	1.5	1.2	8.3	7.8	159
8	150	2.50	2.8	2.4	7.3	8.8	134
	300	2.88	2.4	2.3	8.7	9.0	160
	600	4.00	1.8	1.8	10.0	9.2	302
10	150	2.81	3.5	3.3	8.8	10.0	168
	300	3.25	3.2	3.1	9.9	10.5	304
	600	4.62	2.7	2.0	12.2	11.1	436
12	150	3.19	4.4	4.1	10.7	11.5	223
	300	3.62	3.9	3.9	11.6	11.9	369
	600	5.50	3.2	2.5	13.5	12.6	550
14	150	3.62	4.5	4.6	11.6	12.0	346
	300	4.62	4.3	3.8	13.4	12.8	567
	600	6.12	3.2	2.6	14.7	14.0	752
16	150	4.00	5.4	5.4	12.9	13.9	432
	300	5.25	4.9	4.3	14.6	15.6	697
	600	7.00	3.8	3.4	16.0	15.9	972

(1) For actuator dimensions, refer to pages 18 and 19.

(2) Weight equals weight of the valve plus the actuator.

Dimensions⁽¹⁾

Lug style, NPS 18 to 60 (DN 450 to 600), Class 150 to 600 (PN 10 to 40)

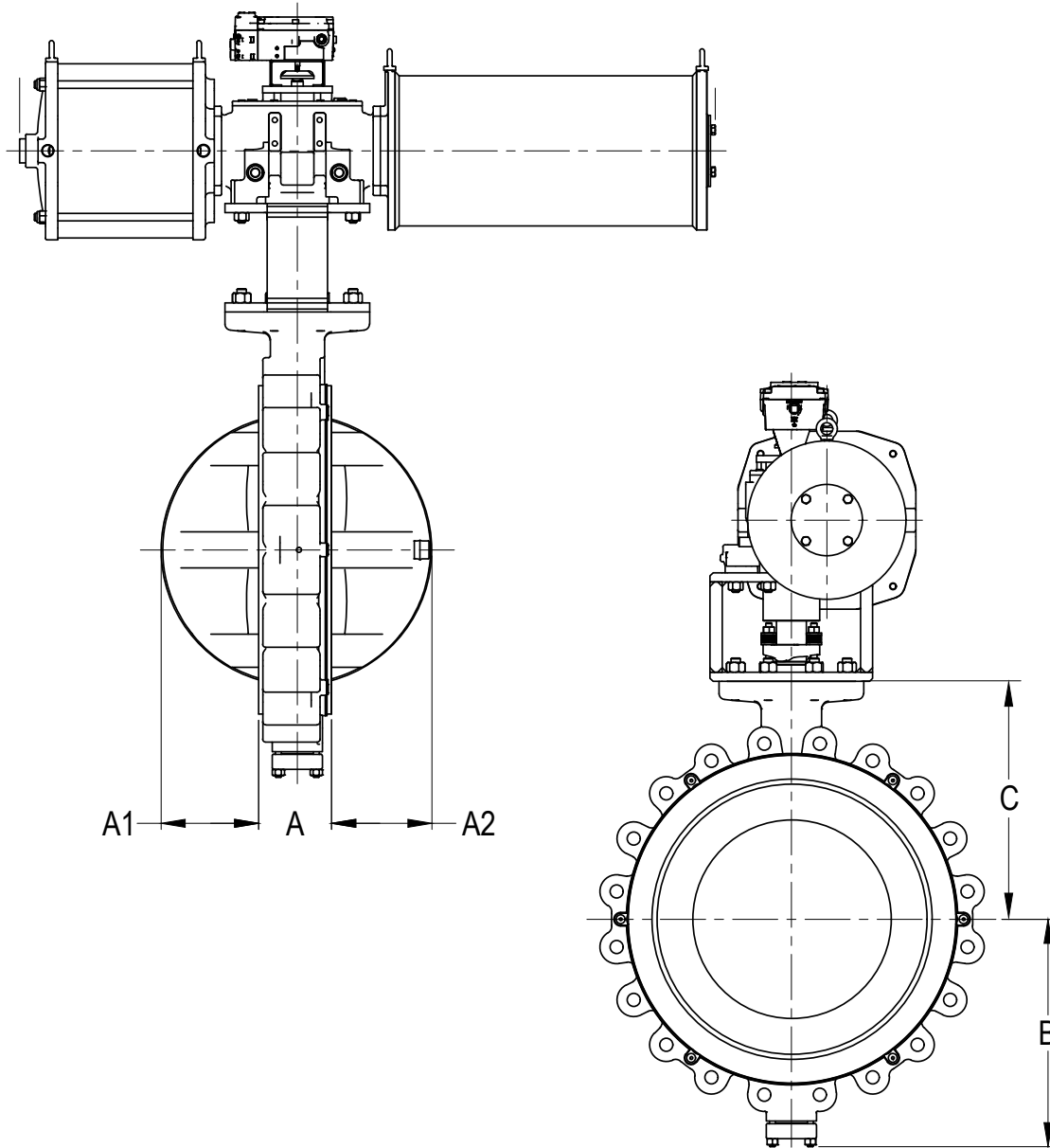

(1) For actuator dimensions, refer to the relevant actuator technical bulletin.

Table 12: Dimensions⁽¹⁾ – Lug style, NPS 18 to 60 (DN 450 to 600), Class 150 to 600 (PN 10 to 40)

Metric

Valve Size	ASME, mm						Valve Size	Pressure Rating	DIN, mm					Actuator Mounting Pattern	Weight ⁽²⁾ , kg
	Class	A	A1	A2	B	C			A	A1	A2	B	C		
18	150	114	154	151	381	396	DN 450	PN 10/16/25	114	154	151	398	396	F16	170
	300	149	132	128	417	404		PN 40	152	132	125	410	404	F30	313
	600	200	100	103	454	442		-	-	-	-	-	-	F35	469
20	150	127	173	181	414	441	DN 500	PN 10/16/25	127	173	181	413	438	F25	240
	300	159	147	147	454	454		PN 40	152	153	146	450	454	F30	370
	600	216	109	123	474	507		-	-	-	-	-	-	F40	642
24	150	154	205	212	479	505	DN 600	PN 10/16/25	154	205	212	478	502	F25	370
	300	181	189	182	524	543		PN 40	178	189	182	528	538	F35	629
	600	232	143	152	545	553		-	-	-	-	-	-	F40	952
28	150	162	261	254	542	637	-	-	-	-	-	-	F25	528	
30	150	165	290	274	580	669	-	-	-	-	-	-	F30	624	
36	150	200	349	332	681	777	-	-	-	-	-	-	F35	1,313	
42	150	251	399	370	793	881	-	-	-	-	-	-	F40	1,615	
48	150	276	458	436	881	983	-	-	-	-	-	-	F48	2,263	
54	150	270	533	520	956	1,067	-	-	-	-	-	-	F48	2,946	
60	150	286	609	583	1,034	1,151	-	-	-	-	-	-	F48	3,810	

U.S.

Valve Size	ASME, in.						Actuator Mounting Pattern	Weight ⁽²⁾ , lb
	Class	A	A1	A2	B	C		
18	150	4.50	6.1	6.0	15.0	15.6	F16	375
	300	5.88	5.2	5.0	16.4	15.9	F30	690
	600	7.88	3.9	4.1	17.9	17.4	F35	1,035
20	150	5.00	6.8	7.1	16.3	17.4	F25	530
	300	6.25	5.8	5.8	17.9	17.9	F30	815
	600	8.50	4.3	4.9	18.7	20.0	F40	1,415
24	150	6.06	8.1	8.3	18.9	19.9	F25	816
	300	7.12	7.5	7.2	20.6	21.4	F35	1,388
	600	9.13	5.6	6.0	21.5	21.8	F40	2,100
28	150	6.38	10.3	10.0	21.4	25.1	F25	1,165
30	150	6.50	11.4	10.8	22.8	26.4	F30	1,377
36	150	7.88	13.7	13.1	26.8	30.6	F35	2,895
42	150	9.88	15.7	14.6	31.2	34.7	F40	3,560
48	150	10.88	18.1	17.2	34.7	38.7	F48	4,990
54	150	10.62	21.0	20.5	37.6	42.0	F48	6,496
60	150	11.25	24.0	23.0	40.7	45.3	F48	8,400

(1) For actuator dimensions, please see the relevant actuator technical bulletin.

(2) Weight is only for body sub-assembly.

VR actuator dimensions

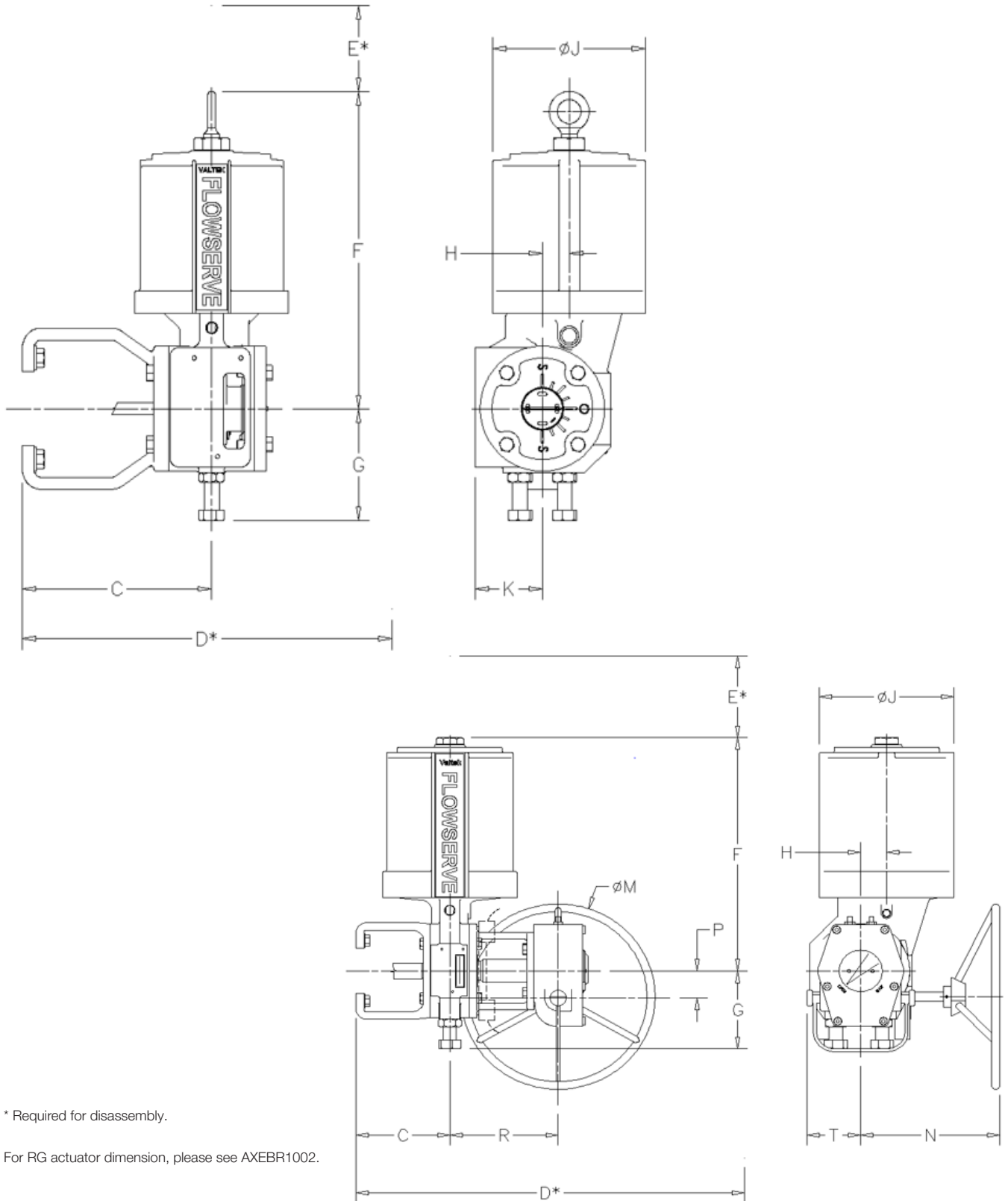

* Required for disassembly.

For RG actuator dimension, please see AXEBR1002.

Table 13: VR actuator dimensions and weights

Actuator Size	Hand-wheel	Spring	C		D		E		F		G		H		J		Weight	
			mm	in.	mm	in.	mm	in.	mm	in.	mm	in.	mm	in.	mm	in.	kg	lbs
25	None	Standard	170	6.7	439	17.3	152	6.0	338	13.3	119	4.7	28	1.1	165	6.5	12	26
		Extended	170	6.7	439	17.3	236	9.3	439	17.3	119	4.7	28	1.1	165	6.5	14	31
	HW	Standard	170	6.7	752	29.6	152	6.0	338	13.3	119	4.7	28	1.1	165	6.5	26	57
		Extended	170	6.7	752	29.6	236	9.3	439	17.3	119	4.7	28	1.1	165	6.5	28	62
50	None	Standard	170	6.7	597	23.5	203	8.0	467	18.4	145	5.7	51	2.0	231	9.1	27	59
		Extended	170	6.7	597	23.5	249	9.8	610	24.0	145	5.7	51	2.0	231	9.1	32	71
	HW	Standard	170	6.7	1,003	39.5	203	8.0	467	18.4	145	5.7	51	2.0	231	9.1	62	137
		Extended	170	6.7	1,003	39.5	249	9.8	610	24.0	145	5.7	51	2.0	231	9.1	68	149
100	None	Standard	170	6.7	686	27.0	279	11.0	577	22.7	193	7.6	61	2.4	318	12.5	63	140
		Dual	170	6.7	686	27.0	279	11.0	577	22.7	193	7.6	61	2.4	318	12.5	68	150
	HW	Standard	170	6.7	1,171	46.1	279	11.0	577	22.7	193	7.6	61	2.4	318	12.5	124	273
		Dual	170	6.7	1,171	46.1	279	11.0	577	22.7	193	7.6	61	2.4	318	12.5	128	283
200	None	Standard	170	6.7	686	27.0	279	11.0	592	23.3	193	7.6	61	2.4	445	17.5	91	200
		Dual	170	6.7	686	27.0	279	11.0	592	23.3	193	7.6	61	2.4	445	17.5	95	210
	HW	Standard	170	6.7	1,171	46.1	279	11.0	592	23.3	193	7.6	61	2.4	445	17.5	113	250
		Dual	170	6.7	1,171	46.1	279	11.0	592	23.3	193	7.6	61	2.4	445	17.5	118	260

Actuator Size	Hand-wheel	Spring	K		M		N		P		R		T		Weight		
			mm	in.	mm	in.	mm	in.	mm	in.	mm	in.	mm	in.	kg	lbs	
25	None	Standard	71	2.8	N/A	N/A	N/A	N/A	N/A	N/A	N/A	N/A	N/A	N/A	N/A	12	26
		Extended	71	2.8	N/A	N/A	N/A	N/A	N/A	N/A	N/A	N/A	N/A	N/A	N/A	14	31
	HW	Standard	N/A	N/A	249	9.8	269	10.6	79	3.1	188	7.4	74	2.9	26	57	
		Extended	N/A	N/A	249	9.8	269	10.6	79	3.1	188	7.4	74	2.9	28	62	
50	None	Standard	94	3.7	N/A	N/A	N/A	N/A	N/A	N/A	N/A	N/A	N/A	N/A	27	59	
		Extended	94	3.7	N/A	N/A	N/A	N/A	N/A	N/A	N/A	N/A	N/A	N/A	32	71	
	HW	Standard	N/A	N/A	300	11.8	295	11.6	132	5.2	257	10.1	137	5.4	62	137	
		Extended	N/A	N/A	300	11.8	295	11.6	132	5.2	257	10.1	137	5.4	68	149	
100	None	Standard	122	4.8	N/A	N/A	N/A	N/A	N/A	N/A	N/A	N/A	N/A	N/A	63	140	
		Dual	122	4.8	N/A	N/A	N/A	N/A	N/A	N/A	N/A	N/A	N/A	N/A	68	150	
	HW	Standard	N/A	N/A	457	18.0	338	13.3	64	2.5	257	10.1	127	5.0	124	273	
		Dual	N/A	N/A	457	18.0	338	13.3	64	2.5	257	10.1	127	5.0	128	283	
200	None	Standard	122	4.8	N/A	N/A	N/A	N/A	N/A	N/A	N/A	N/A	N/A	N/A	91	200	
		Dual	122	4.8	N/A	N/A	N/A	N/A	N/A	N/A	N/A	N/A	N/A	N/A	95	210	
	HW	Standard	N/A	N/A	457	18.0	338	13.3	64	2.5	257	10.1	127	5.0	113	250	
		Dual	N/A	N/A	457	18.0	338	13.3	64	2.5	257	10.1	127	5.0	118	260	

Mounting orientations

Figure 10: Valve orientations

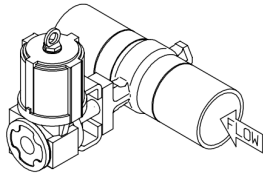

Left-hand mount (standard)

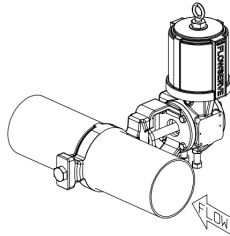

Right-hand mount

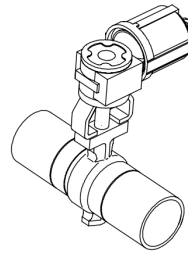

Vertical shaft mount

Note: Valve orientations not applicable for vertical pipe.

Figure 11: Actuator orientations

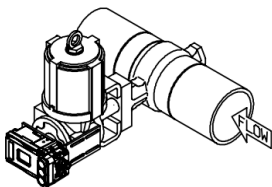

Orientation 1 (standard)

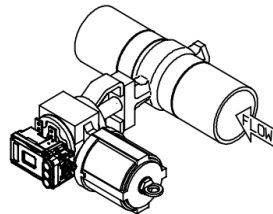

Orientation 2

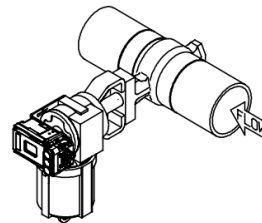

Orientation 3

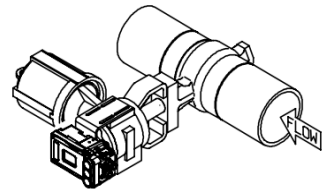

Orientation 4

Note: Images shown with the valve mounted in the left-hand orientation as an example only. Actuator orientations may also accommodate the valve mounted in the right-hand or vertical shaft orientations.

- For right-hand mount, move flow arrow point of view to opposite end of the pipe.
- For vertical shaft mount, rotate valve shaft to vertical orientation.

Note: Orientation 3 is not recommended by factory due to retaining ring

corrosion and subsequent failure from water standing in actuator.

Figure 12: Handwheel orientations

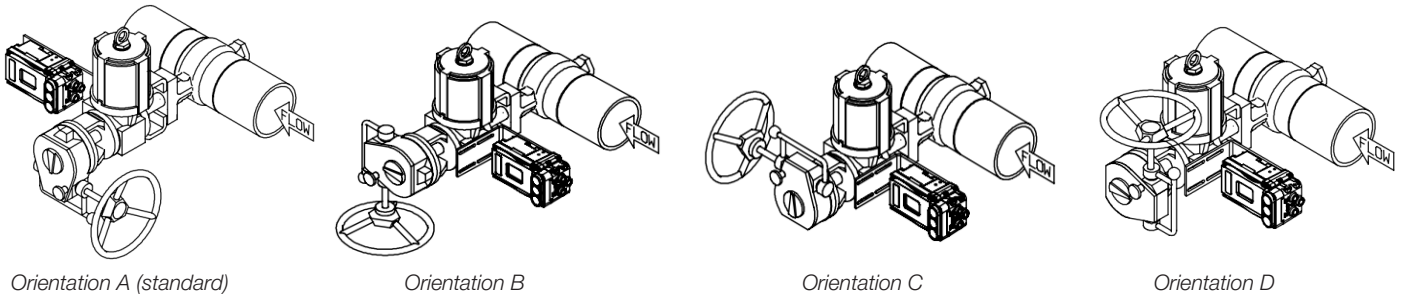

Note: Images shown with the valve mounted in the left-hand orientation as an example only. Actuator orientations may also accommodate the valve mounted in the right-hand or vertical shaft orientations.

- For right-hand mount, move flow arrow point of view to opposite end of the pipe.
- For vertical shaft mount, rotate valve shaft to vertical orientation.

Note: Orientation D is not recommended, as handwheel may collide with larger actuators. Consult factory if chosen.

Logix™ 3800 digital positioner

You can have it all: simple configuration and calibration, powerful diagnostics and reliable performance.

The Logix 3800 digital positioner from Flowserve helps plant owners and operators maximize production while minimizing operating costs. This high-precision positioner simplifies installation through easy configuration and calibration. It also facilitates improvements in process uptime, reliability and throughput. Advanced diagnostics not only identify developing problems in the control valve, but also help guide corrective actions to ensure reduced return-to-operation times.

Predictive diagnostics

With five pressure sensors, the Logix 3800 digital positioner enables operators to identify and assess the severity of developing problems in valves and actuators so action can be taken before a critical event.

- Supply pressure warning — Monitors the instrument air supply pressure
- Friction high/low warnings — Monitor the adjustment of the packing and seals
- Pneumatic leak warning — Monitors excessive air consumption indicating leaks in actuator or tubing
- Fail-safe position error — Detects problems with the fail-safe actuator spring
- Backlash warning — Monitors the linkage of the actuator to the valve and detects loose connections



Global service network



Service when and where you need it most

Flowserve Quick Response Centers (QRCs) are strategically located around the world to ensure rapid response to your time-critical repair needs, routine maintenance and product upgrades.

Single point of contact

Our QRCs serve as a local, single point of contact for the full inventory of Flowserve products and services, including the machinery to manufacture custom-built units. We offer better than 95% on-time performance for all repairs and can turn around new and custom-built units within 72 hours.

Time-critical repairs

To meet your time-critical repair needs, Flowserve offers 24-hour emergency repair, free pick-up and delivery within QRC service areas, and mobile and on-site repairs. When a service technician is needed on-site, we can have one there within 24 hours anywhere in North America, and 48 hours outside of North America.

To locate a Flowserve representative near you, visit www.flowserve.com



Flowserve Corporation
5215 North O'Connor Blvd.
Suite 700
Irving, Texas 75039-5421 USA

VATB000262-02 (EN/A4) June 2023

Flowserve Corporation has established industry leadership in the design and manufacture of its products. When properly selected, this Flowserve product is designed to perform its intended function safely during its useful life. However, the purchaser or user of Flowserve products should be aware that Flowserve products might be used in numerous applications under a wide variety of industrial service conditions. Although Flowserve can provide general guidelines, it cannot provide specific data and warnings for all possible applications. The purchaser/user must therefore assume the ultimate responsibility for the proper sizing and selection, installation, operation, and maintenance of Flowserve products. The purchaser/user should read and understand the Installation Instructions included with the product, and train its employees and contractors in the safe use of Flowserve products in connection with the specific application.

While the information and specifications contained in this literature are believed to be accurate, they are supplied for informative purposes only and should not be considered certified or as a guarantee of satisfactory results by reliance thereon. Nothing contained herein is to be construed as a warranty or guarantee, express or implied, regarding any matter with respect to this product. Because Flowserve is continually improving and upgrading its product design, the specifications, dimensions and information contained herein are subject to change without notice. Should any question arise concerning these provisions, the purchaser/user should contact Flowserve Corporation at any one of its worldwide operations or offices.

©2023 Flowserve Corporation. All rights reserved. This document contains registered and unregistered trademarks of Flowserve Corporation. Other company, product, or service names may be trademarks or service marks of their respective companies.