

Titan™ T400

Cone Crusher



Crusher

- Full top service
- Patented Hybrid Bearings
 - More stable cone head
 - Higher capacity
 - Less friction
 - Allows easy, more frequent bearing inspection
- Re-usable Concave Collet
 - No wedges or sledge hammer required
- Patented Thread Scraper
- Metric Design
- Thread Locking Mechanism
- Patented Anti-Spin System
 - Hydraulic restraint
 - Uses cone-lube oil
 - Automatic reset
 - Less parts/repair cost
- Balanced eccentric assembly
 - No socket or socket liner to remove
- FEA Stress Analysis
- Cast Steel Frame With Bronze Radial and Thrust Bearings
- Hydraulic Relief and Clearing System
- Dynamic Bowl Adjust System
- Receiving hopper
- Manganese chamber liners
- Per-wired alarm panel and hydraulics operation panels
- Basic tool kit
- Operation and maintenance manuals

Oil Lube System

- 10/15hp oil pump assembly
- 95gal (360L) tank oil
- Oil filter(s)
- (2) 3kW oil heaters

Hydraulic System

- 15/20hp pump assembly
- 30gal (114L) tank
- Pressure and return filters
- 3kW oil heater, cooler, and control panel with pendant

TRAC10® Automation System (Optional)

- Operator Interface Terminal - 12" full color touchscreen display
- Remote crusher setting adjustment and tracking
- Overload protection
- Automatic liner calibration
- Liner wear tracking and compensation
- Ability to modify settings while crushing
- Parameter history, alarm logging, and PLC communication
- Package can operate up to 4 crushers with one display

Crusher Options

- Electric motor(s)
- Motor slide rails
- V-belt drive and guard
- Air-to-oil cooling system
- High ambient/high altitude air-to-oil cooling system
- Cold weather package
- Stationary feed basket
- Deluxe tool kit including all lifting devices
- TRAC10® Automatic power adjust mode
- TRAC10® Automatic feed control
- TRAC10® Wi-Fi connection
- TRAC10® Remote diagnostics package

	T200	T300	T400	T500
A	66.20" (1,682 mm)	74.85" (1,902 mm)	80.05" (2,034 mm)	88.68" (2,253 mm)
B	59.20" (1,504 mm)	67.85" (1,724 mm)	73.05" (1,856 mm)	81.68" (2,075 mm)
C	18.11" (460 mm)	19.29" (490 mm)	20.58 (523mm)	
D	39.76" (1,010 mm)	44.49" (1,131 mm)	48.82" (1,241 mm)	57.25" (1,455 mm)
E	46.85" (1,190 mm)	55.75" (1,417 mm)	65.11" (1,654 mm)	74.69" (1,898 mm)
F	62.60" (1,591 mm)	74.80" (1,900 mm)	92.52" (2,351 mm)	107.09" (2,721 mm)
H	77.08" (1,958 mm)	89.87" (2,283 mm)	105.75" (2,687 mm)	114.34" (2,905 mm)
I	35.94" (913 mm)	42in (1,067mm)	54.44" (1,383 mm)	57.09" (1,451 mm)
J	41.14" (1,045 mm)	44.49" (1,131 mm)	51.31" (1,304 mm)	57.25" (1,455 mm)
L	42.91" (1,090 mm)	51.97" (1,321 mm)	65.35" (1,660 mm)	69.5" (1,766 mm)
M	21.46" (546 mm)	25.98" (660 mm)	32.68" (831 mm)	34.75" (883 mm)
N	51.57" (1,310 mm)	62.99" (1,600 mm)	74.41" (1,891 mm)	83.45" (2,120 mm)
O	21.46" (546 mm)	25.98" (660mm)	32.68" (831 mm)	34.75" (883 mm)
P	42.91" (1,090 mm)	51.97" (1,321 mm)	65.35" (1,660 mm)	69.50" (1,766 mm)

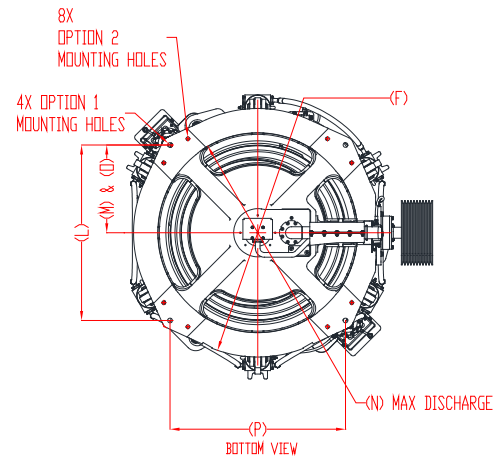
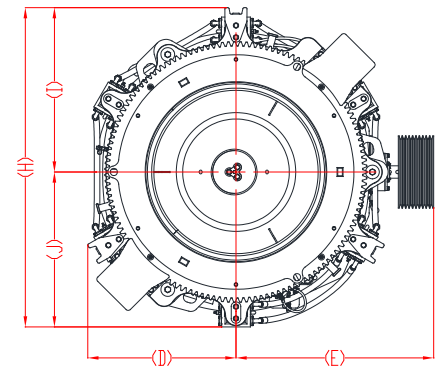
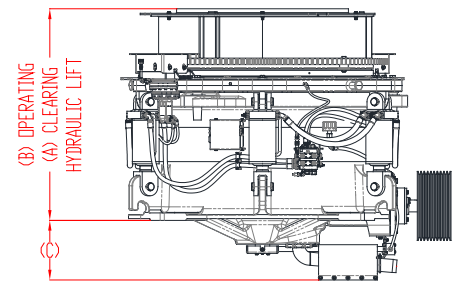

	T200	T300	T400	T500
Head Diameter	36" (915mm)	44" (1,120mm)	52" (1,321mm)	57" (1,450mm)
Operating Range	900 - 1,100 RPM	850 - 1,050 RPM	825 - 1,050 RPM	825 - 1,050 RPM
Maximum Feed Size*	8.70" (220mm)	11.20" (285mm)	12.30" (314mm)	14.20" (36mm)
Clearing Stroke	7" (178mm)	7" (178mm)	7" (178mm)	7" (178mm)
Horsepower	200 (150kw)	300 (225kw)	400 (300kw)	500 (375kw)
Total Weight	22,000lb (9,979kg)	35,800 lb (16,239kg)	51,800lb (23,496 kg)	75,100lb (34,065kg)
Upper Frame Assembly with Liner	8,000lb (3,629kg)	12,900lb (5,851kg)	18,000lb (8,165 kg)	26,500lb (12,020kg)
Main Frame Assembly with Main Shaft and Liners	8,790lb (3,987kg)	12,200lb (5,534 kg)	17,800 lb (8,074kg)	26,900 lbs (12,202kg)