

◀ TD-120
TD-14
TDT-340
Appearance Dimensions

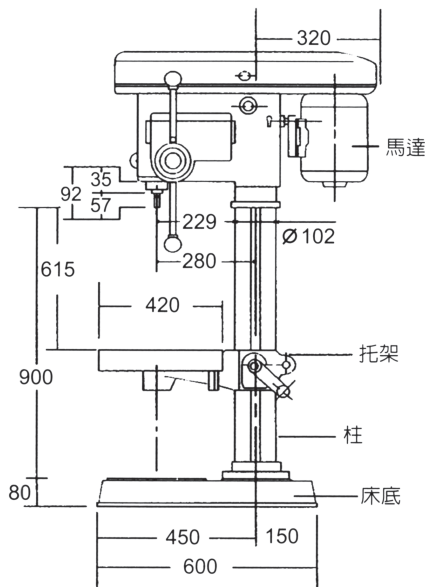
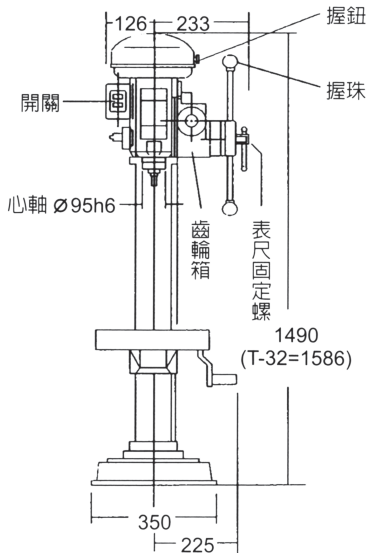

◀ TD-250 TD-25
TDT-25 TDT-32
Appearance Dimensions

Dimensions		Model		Auto Stroke		Manual Stroke		Tapping Manual Stroke		
		TD-120	TD-250	TD-14	TD-25	TDT-340	TDT-25	TDT-32		
Taper	Spindle	MT 2#	MT 3#	MT 2#	MT 3#	MT 2#	MT 3#	MT 2#	MT 3#	MT 3#
	Chuck	JT 6#	JT 6#	JT 6#	JT 6#	JT 6#	JT 6#	JT 6#	JT 6#	JT 6#
Max. drilling capacity(mm)		Ø16	Ø25	Ø16	Ø25	攻牙Ø13 鑽孔Ø16	攻牙Ø18 鑽孔Ø25	鑽孔	攻牙Ø32	
Spindle Stroke(mm)		93	133	100	140	100	140	140		
Motor		1HP	2HP	1HP	2HP	1HP	2HP	2HP		
Choices of speed		4	9	4	9	9	9	4		
Spindle R.P.M.	Range	50Hz	466~1675	200~1600	480~2300	160~1342	250~960	160~1342	55~175	
		60Hz	560~2010	210~1700	550~2700	190~1610	300~1150	190~1610	65~210	
Weight (kg)	WO.Motor	87	180	87	173	86	178	195		
	W.Motor	102	206	102	199	101	204	221		