

SPINDLE STROKE :

	AF-111	AF1-112(AF1-112S)	AF2-126(AF2-126S)
Max. drilling capacity(mm)	Ø6	Ø6	Ø9
Spindle nose taper	J.T.1		J.T.6
Max. spindle stroke(mm)	80		120
Drilling feed stroke	50		90
Min.required rapid feed stroke	30		30
Spindle speed(r.p.m)	6000,4000,2700,1800,1200,800		5000, 3550, 2500, 1800, 1250, 900
Drilling feed rate(mm/sec)	0.4~20		0.4~20
Thrust power(AT 5kg/cm ²)kgf	100(kgf)		150(kgf)
Working air pressure(kgf/cm ²)	5		5
Motor 3-Phases	2相Phases-2P-200W		3相Phases-2P-375W
Weight	15		31

尺寸圖

⑩ 直結型

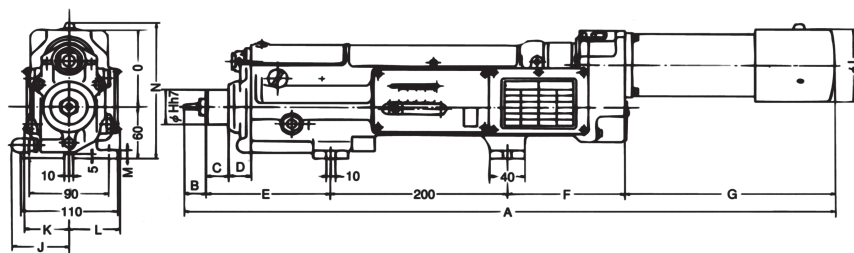

⑪ 折返し型

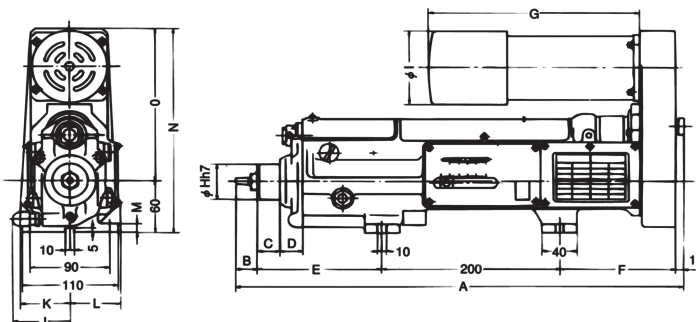

給気ジョイント：エルボユニオンSRL-081¹/₈"

尺寸表(mm) :

機種	記號	A	B	C	D	E	F	G	H	I	J	K	L	M	N	O	主軸端型式
標準タイプ	AF1-111	753	25	25	25	140	132	256	42	84.6	65	50	56	10	160	90	JT No.1
	AF2-125	920	40	33	27	125	268	287	60	104	70	63	63	12	205	119	JT No.6
	AF1-112	506	25	25	25	140	130	256	42	84.6	65	56	56	10	242	189	JT No.1
	AF2-126	646	40	33	27	125	270	287	60	104	70	63	63	12	296	236	JT No.6

鑽孔能力(mm) :

r.p.m 主軸回轉數	被削材質 軸數	鋼(S45C)				鑄鐵(F C20)				鋁合金(A1100)			
		1軸	2軸	3軸	4軸	1軸	2軸	3軸	4軸	1軸	2軸	3軸	4軸
AF1	800	8	4	3	2.5	10	5	3.5	3.5	10	5	3.5	3.5
	1200	6	3	2.5	2	8	4	3.5	3	8	4	3.5	3
	1800	4	2.5	2	1.5	6	3.5	3	2	6	3.5	3	2
	2700	3	2	1.5		4	2.5	2		4	3	2	
	4000	2	1.5			3	2			3	2		
	6000	1				2				2			
AF2	900	9	6	5	4	11	7	5.5	4.5	12	7	5.5	4.5
	1250	7	5.5	4	3	9	6	5	3.5	10	6	5	3.5
	1800	6	5	3	2	7	5.5	3.5	2.5	9	5.5	3.5	2.5
	2500	5	4	2.5		6	4.5	3		6	4.5	3	
	3550	3	2.5			4	3			5	3		
	5000	2				3				3			