

SPRAYTHRU™ AND RINSEMASTER® SYSTEMS



SprayThru™ Systems, for barrels or racks, decrease plating times and improve plating uniformity. **RinseMaster® Systems** reduce water consumption, leave parts without dragout, and save line length.

The **SprayThru Barrel** is used in both the **SprayThru Plating** and **RinseMaster** systems. The **RinseMaster** system can also be utilized for rack plating. The RinseMaster uses a single tank to achieve the

equivalent water savings of a 5 station counterflow rinse, leaving parts clean and free of cross contamination.

Designed to grow with your needs, all systems are upgradeable and can be incorporated into existing lines. A new **RinseMaster Tank Conversion Kit** allows you to convert your existing tanks for use with the **RinseMaster System**.

The SprayThru™ Barrel

The **SprayThru™** barrel is the heart of Hardwood Line's high efficiency **SprayThru™** Plating and Rinsing systems.

The **SprayThru** barrel is equipped with either an internal spray nozzle or spray bar. This enables solution or water to be sprayed directly inside the barrel. When used in a plating station, solution can be pumped directly inside the barrel. This provides a higher level of concentrated solution next to the parts during the plating cycle thereby yielding faster, higher quality plating.

The **SprayThru** barrel can also be utilized on all the process tanks on your line. When coupled with a **RinseMaster** rinsing system it delivers rinse water directly to the load.

The **SprayThru** barrel is available in a complete range of sizes and cylinder configurations and can be retrofitted to your existing superstructure.

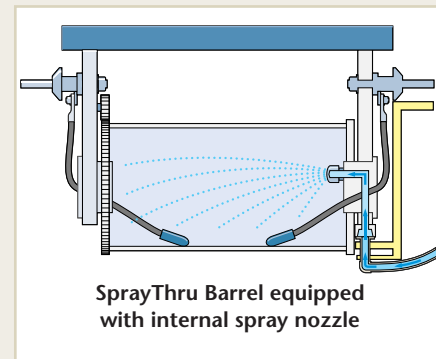

SprayThru Barrel equipped with internal spray nozzle

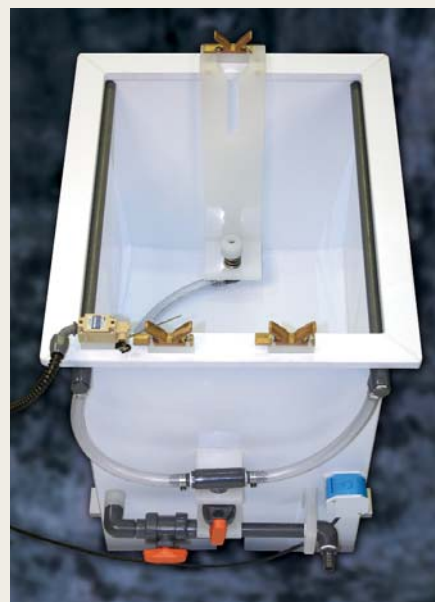

RinseMaster Tank

SprayThru Tanks can either be configured as process tanks or rinse tanks. When a **SprayThru** barrel is seated on a Z-Bracket, a switch on the tank saddle activates either the **RinseMaster** on a rinse tank or a solution pump on a **SprayThru** process tank.

The **RinseMaster** tank is a single station tank equipped with perforated spray bars and a Z-bracket. A barrel is rinsed from the inside and outside while racks are sprayed from both sides, top and bottom to ensure complete coverage.

A pitched bottom allows spent rinse water to be re-directed to the appropriate tank or location. Since a **RinseMaster** only requires one tank, valuable floor space can be re-allocated to more cost efficient process stations thereby further increasing productivity.

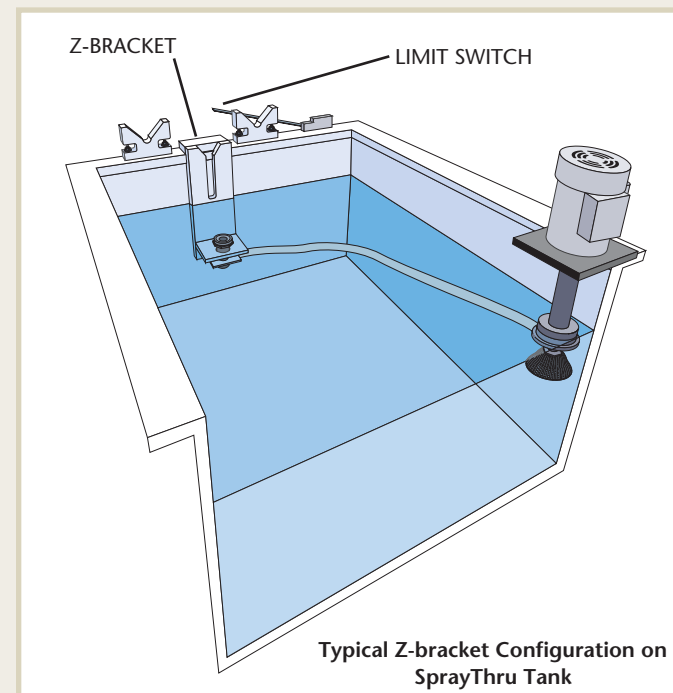

Typical Z-bracket Configuration on SprayThru Tank

1 UNIT DRAGOUT

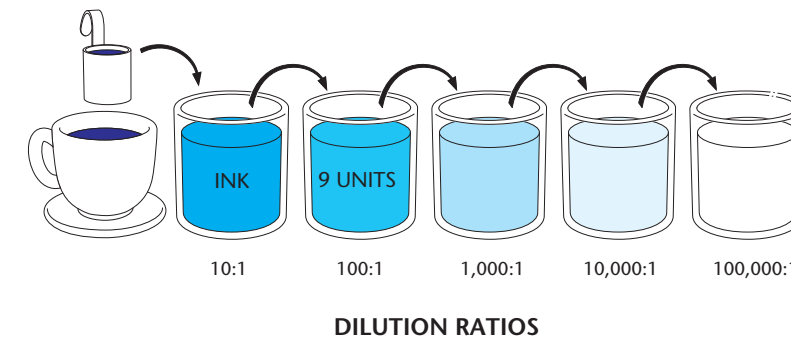

DILUTION RATIOS

THE PRINCIPLE BEHIND COUNTERFLOW RINSING

This diagram illustrates the principle of counterflow rinsing. As the ladle representing dragout is moved from tank #1 to tank #2, the dragout is diluted by a ratio of 10 to 1. Each successive tank further increases this dilution ratio by 10 to 1. At tank #5 the dilution ratio is 100,000 to 1. (See table on back page)

Counterflow rinsing, long the industry standard for maximum efficiency, always required multiple rinse stations. The more rinse stations in a line, the better the rinse quality. However, this increase in rinse quality was offset by the fact that now, more valuable floor space was being utilized for rinsing operations; space that could be dedicated to more cost efficient process stations. In addition, more stations resulted in wasted time for multiple transfers. Any gain made in rinse efficiency was lost to inefficient use of floor space and increased cost.

The **RinseMaster®** delivers five counterflow sprays to either a rack or barrel inside a rinsing tank. Each of the five sprays rinse the work with progressively cleaner water – ending with a fresh water spray.

During each rinse cycle, only the water used in the first spray is redirected away from the system or processed for recovery. The subsequent sprays are collected by the **RinseMaster** for reuse in the following cycles.

The net result is exceptional rinse ratios using very little water. Since only the water from the first spray in the five spray cycle is discharged, it is only that relatively small amount that requires further handling. In some cases the water collected from the first spray can be used to make up for losses due to either evaporation or dragout from the barrel or rack. This unique situation can result in an almost totally closed loop system without waste treatment.

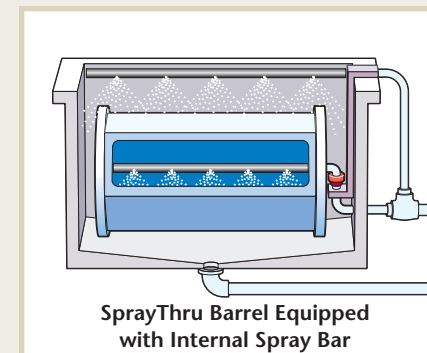

SprayThru Barrel Equipped with Internal Spray Bar

Spray rinsing turns the counterflow concept around. The processed work is not moved from tank to tank, but instead is placed in a single tank where the **RinseMaster** delivers consecutively cleaner water sprays to the barrel or rack.

A **SprayThru** Rinsing System consists of three main components;

- 1) **SprayThru** barrel or rack,
- 2) **RinseMaster** tank,
- 3) **RinseMaster**

This is also an extremely cost effective solution; no replacement cost of lost dragout chemistry; no treatment or disposal costs.

The **RinseMaster** uses a non-pressurized open tank configuration. Removable top and side panels provide easy access to the float switches as well as simplifying periodic cleaning. The two tanks are positioned in a containment tray to capture any spills, should they occur.

The **RinseMaster** uses 2 pumps. An electric pump delivers rinse water to the tank. An air diaphragm pump (AODD) returns sprayed water. Strainers in the return and spray lines prevent suspended particles from making their way back to the holding tanks. An audible pressure sensitive alarm tells you when the filters need cleaning.

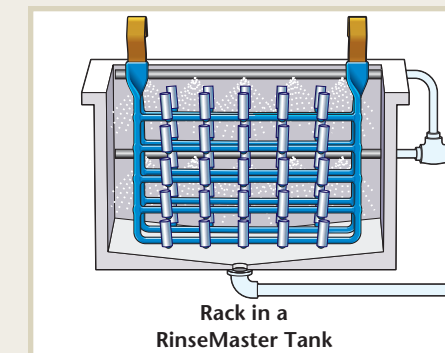

Rack in a RinseMaster Tank

HOW SPRAY RINSING WORKS

THE RinseMaster

HOW THE RinseMaster WORKS

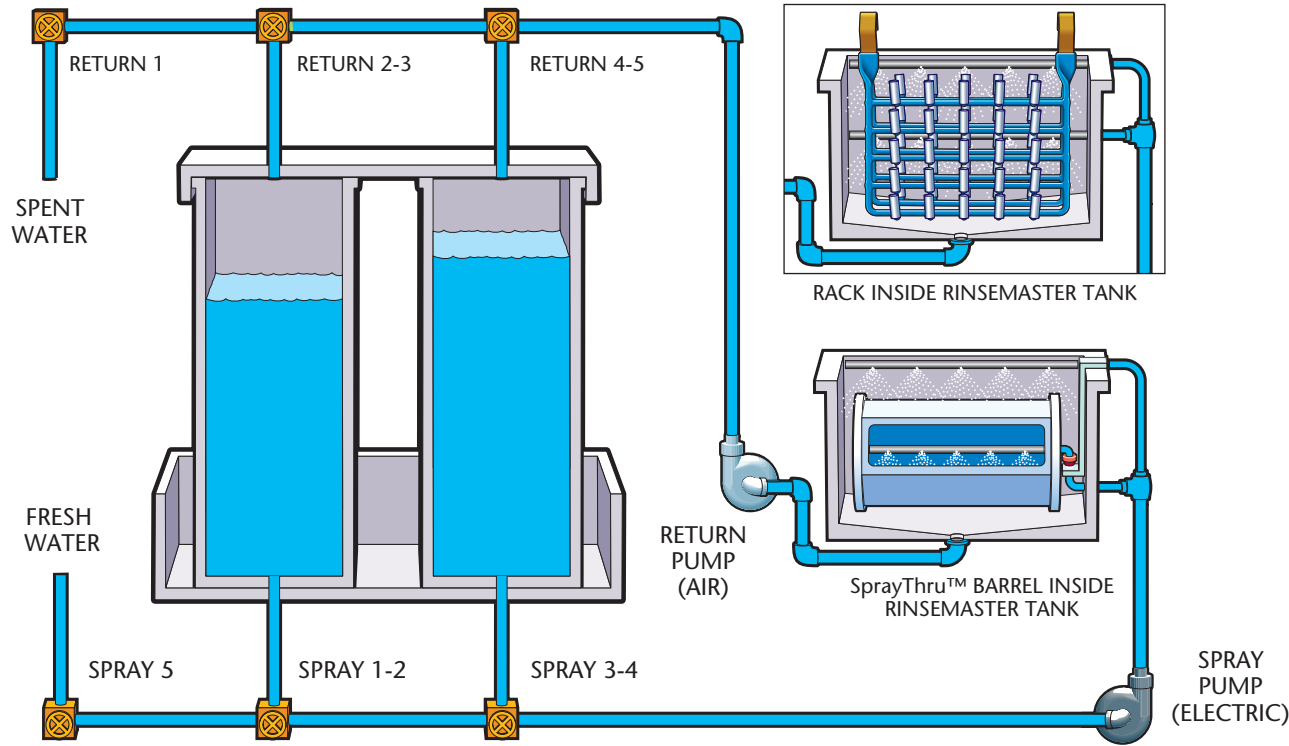

TYPICAL RinseMaster SYSTEM CONFIGURATION

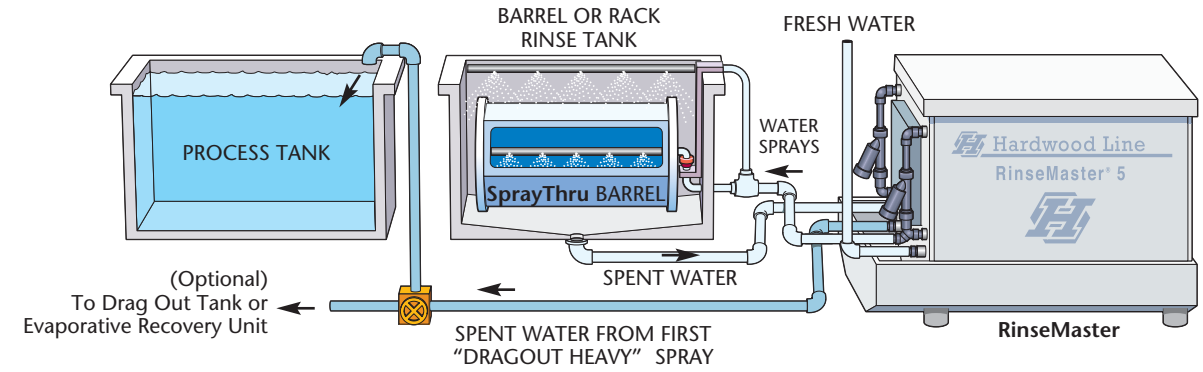

This System Recovers ALL Dragout Chemicals, Eliminating 100% of Waste.

WATER USAGE COMPARISON OF CONVENTIONAL LINES WITH A RINSEMASTER LINE		Line Length feet Meters	Water Usage Per Rinse Station gal/min liters/min	Water Usage Per Load gal/bbl/hr liters/bbl/hr	Total water Usage Per 5 Brls/Hour gal/hr liters/hr	Total Water Usage ⁽²⁾ gal/year liters/year	Water Savings using 5 RinseMasters
Line A	5 Single Running Rinses	42 12.8	4.00 15	240 910	1,200 4,540	4,992,000 18,896,716	97.9%
Line B	5 Triple Counterflow Rinses	68 20.7	1.50 5.7	18 68	90 340	374,000 1,417,253	72.2%
Line C	5 RinseMasters (1)	42 12.8	.42 1.6	5 19	25 95	104,000 393,682	

(1) Each RinseMaster delivers the equivalent of a 5 station counterflow rinse.
 (2) Figures based on a 260 work day year, running two shifts per day.

LINE A - USING SINGLE RINSES

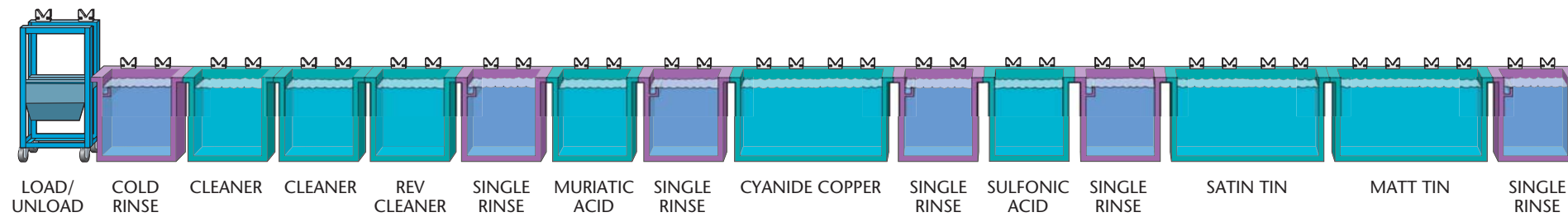

LINE B - USING TRIPLE COUNTERFLOW RINSES

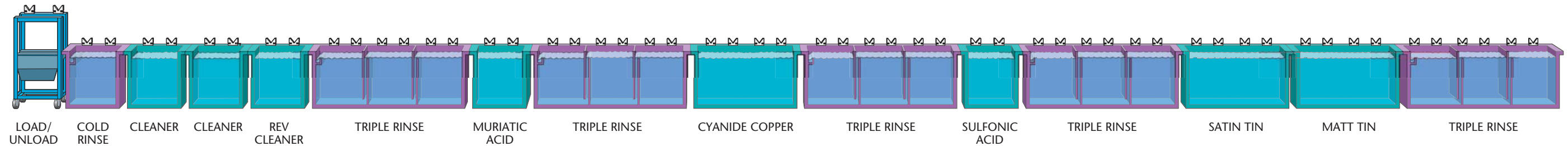

LINE C - USING 5 RINSEMASTERS

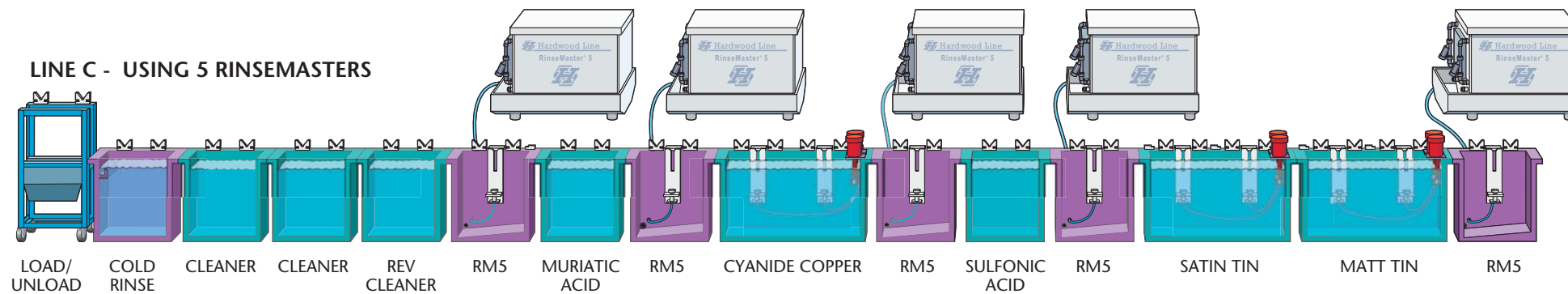

COMPARISON OF CONVENTIONAL LINES WITH A RINSEMASTER LINE

All three lines yield 5 loads per hour and offer similar dilution ratios.
 Line A is 42 feet (12.8m) long and uses 1,200 gallons (4,542 liters) of water per hour.
 Line B is 68 feet (20.7m) long and uses 90 gallons (340 liters) of water per hour.
 Line C is 42 feet (12.8m) long and uses 25 gallons (95 liters) of water per hour.

Line C produces superior plating, improved water conservation and the same output as Lines A & B but uses only a fraction of the water and a small portion of the floor space.

Line C actually delivers the equivalent of five 5-station counterflow rinses as compared to line B which is only providing five 3-station counterflow rinses. It actually provides a better result since the last rinse in Line C is a fresh water rinse.

For water usage comparisons see chart above.

RinseMaster CONSTRUCTION

The RinseMaster is engineered to perform in the demanding plating environment.

Rugged chemically resistant construction insures both maximum durability and minimum maintenance. The system control cabinet houses one micro-processor

controller that allows you to easily modify timer settings to suit your individual requirements. Spray duration, dilution ratios and spray pressure are adjustable for complete flexibility.

RinseMaster FEATURES

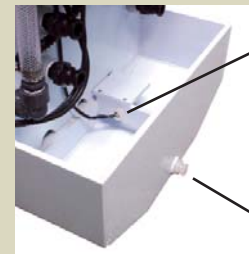

CONTAINMENT ALARM FLOAT SWITCH ALERTS TO ANY LEAKAGE WITHIN THE UNIT

DRAIN PLUG

CONTAINMENT TRAY DETAIL

PROGRAMMABLE CONTROLLER

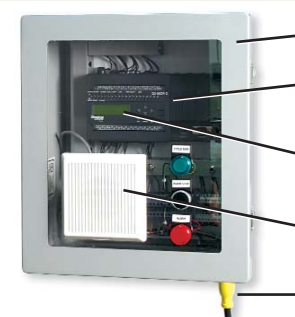

- NON-METALLIC ENCLOSURE
- PLC WITH ADJUSTABLE TIMERS
- ALARM CONDITION DISPLAY
- ALARM HORN
- QUICK DISCONNECT

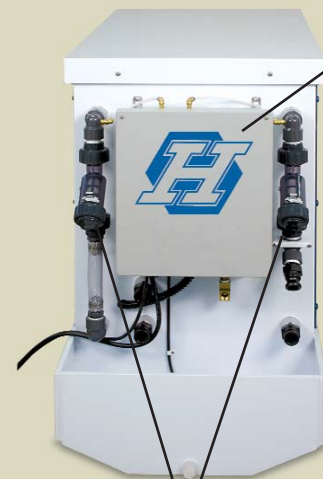

AIR CONTROLS CABINET

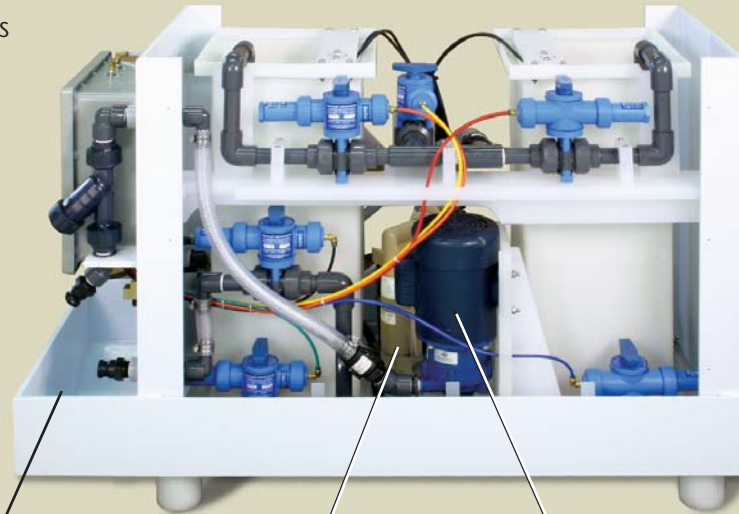

PRESSURE SENSITIVE RETURN AND SPRAY TRAPS

CONTAINMENT TRAY (SEE DETAIL)

AIR OPERATED RETURN PUMP

ELECTRICALLY OPERATED SPRAY PUMP

RinseMaster SPECIFICATIONS

Electrical:	115 to 230 VAC, 1 PH, 50-60 Hz., 15 Amps max.	Operating Weight: (Floor Mounted Unit)	530 lbs., 240 kg
Air:	80 psi min., 5.5 BAR min. 125 psi max., 8.62 BAR max. 104°F max., 40°C max. 40 to 50 cfm, oil free	Dimensions:	57"L x 24"W x 37-1/2"H 145cm L x 61cm W x 95cm (Before External Connections)
Ambient Air:	33°F to 104°F, .6°C to 40°C	Minimum Cycle Time:	1.5 Minutes (approx.)
Water:	130°F max., 54.4°C max. 25-100 psi, 1.72-6.8 BAR	Maximum Cycle Time:	30 Minutes (approx.)
Approx. Shipping Weight (crated):	385 lbs. approx., 175 kg approx.	Material in Contact with Solution:	EPDM, PE, PP, PVC, Teflon, Viton
Dry Weight (uncrated):	305 lbs., 138 kg	Spray & Return Tubing:	1" ID, 2.54cm ID
		Fresh and Discard Water Connections:	1" FPT & 1" Barbed Fittings 2.54cm FTP & 2.54cm Barbed Fittings

Specifications subject to change without notice.

TANK CONVERSION KITS

SprayThru™ Plating and Rinsing Systems employ four main components;

- 1) The SprayThru barrel,
- 2) The SprayThru Tank
- 3) The RinseMaster
- 4) The RinseMaster Tank

The SprayThru Tank is designed to work with the SprayThru barrel on all the process tanks of your line.

The RinseMaster tank is specifically engineered to integrate with the RinseMaster and its cycle of spray rinses.

Hardwood Line offers two Tank Conversion Kits enabling you to convert your current tanks to either SprayThru tanks or RinseMaster tanks, making them fully compatible with the your SprayThru system.

Each Tank Conversion Kit is custom manufactured to fit your existing tanks and can be easily installed at your facility by your own personnel, saving you both time and money.

SprayThru Tank Conversion Kit

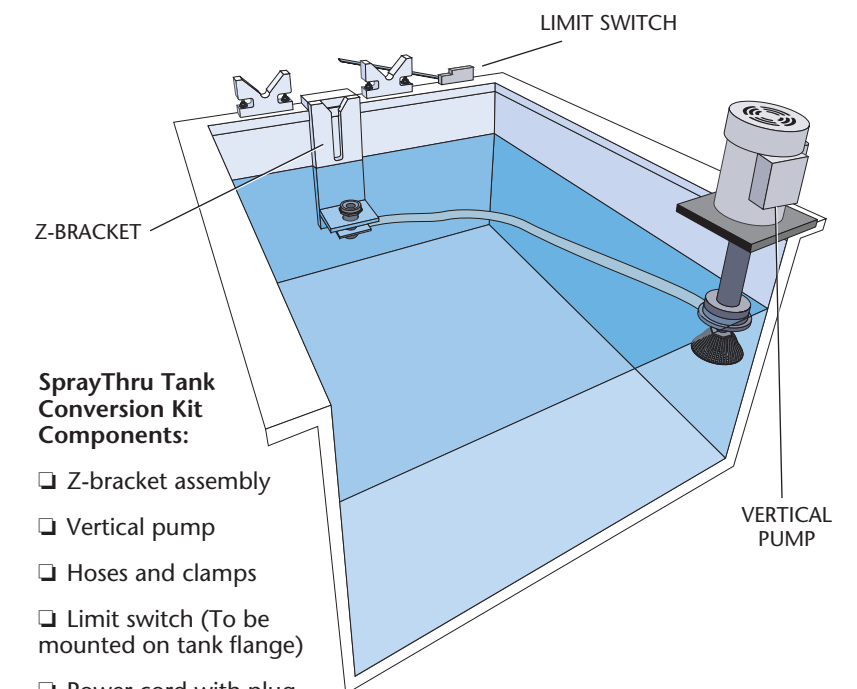

SprayThru Tank Conversion Kit Components:

- Z-bracket assembly
- Vertical pump
- Hoses and clamps
- Limit switch (To be mounted on tank flange)
- Power cord with plug
- Installation instructions

RinseMaster Tank Conversion Kit

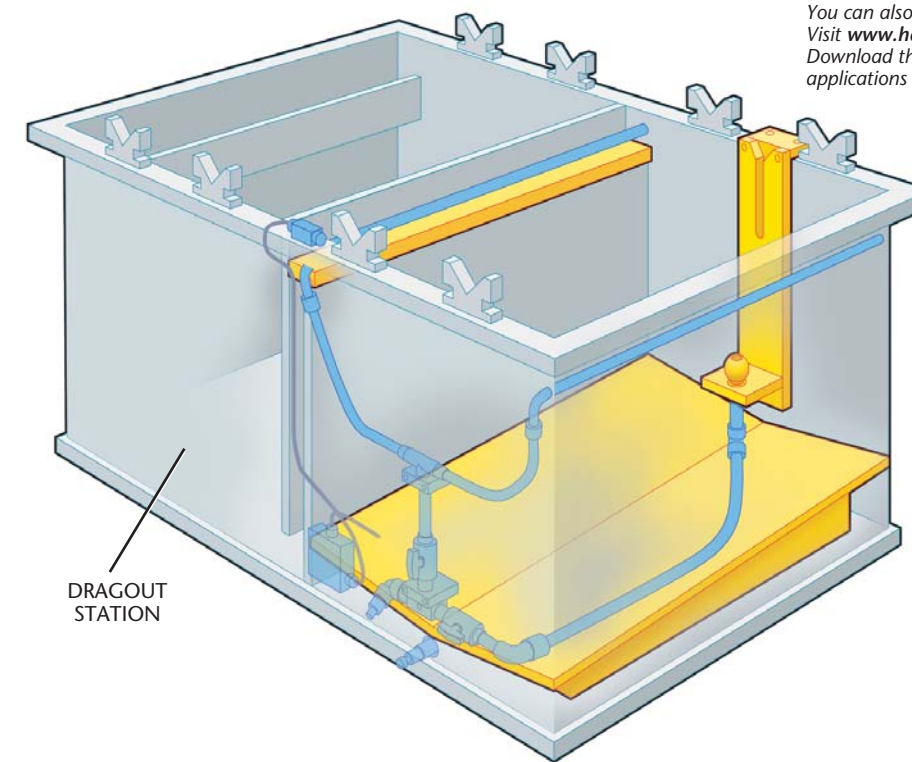

To help us assist you in specifying a Tank Conversion Kit, Call us at 800-443-0093 and we will fax you a "specs" form. You can also download this form from our website. Visit www.hardwoodline.com. Click on the Literature button. Download the file called "Tank Conversion Brl.pdf" for barrel applications or "Tank Conversion Racks.pdf" for rack applications.

RinseMaster Tank Conversion Kit Components:

- Sloped bottom assembly
- Tube of sealer
- Z-bracket assembly
- Pipe and valve assembly
- Top plugs
- Hoses and clamps
- Junction box assembly (includes liquid level switch & limit switch)
- Bulkhead fitting
- Installation instructions

Highlighted in yellow and blue is a typical RinseMaster Tank Conversion Kit installed into one station of a 2-station rinse tank. The other side is now utilized as a dragout station and plumbed to receive the "solution heavy" discharge from the first spray of the RinseMaster. The overflow of the "dragout" tank is directed back to the process tank, making up for losses due to evaporation and dragout. This greatly reduces the quantity of water sent to waste treatment.

COUNTERFLOW WATER USAGE TABLE

DILUTION RATIO	GALLONS (LITERS) OF WATER TO DILUTE 1 GALLON (LITER) OF DRAGOUT*					COUNTERFLOW RINSES gallons/liters	
	1	2	3	4	5		
100:1	99	10.0	4.7	3.2	2.5	(RinseMaster)	
1,000:1	999	31.0	10.0	5.6	4.0		
5,000:1	4,999	70.0	17.0	8.4	5.5		
10,000:1	9,999	100.0	21.0	10.0	6.3		
20,000:1	19,999	141.0	27.0	12.0	7.2		

* Numbers are approximate. Actual water usage is dependent on flow rates, distribution of rinse water across the load surface and other factors.

BARREL AND RACK USAGE

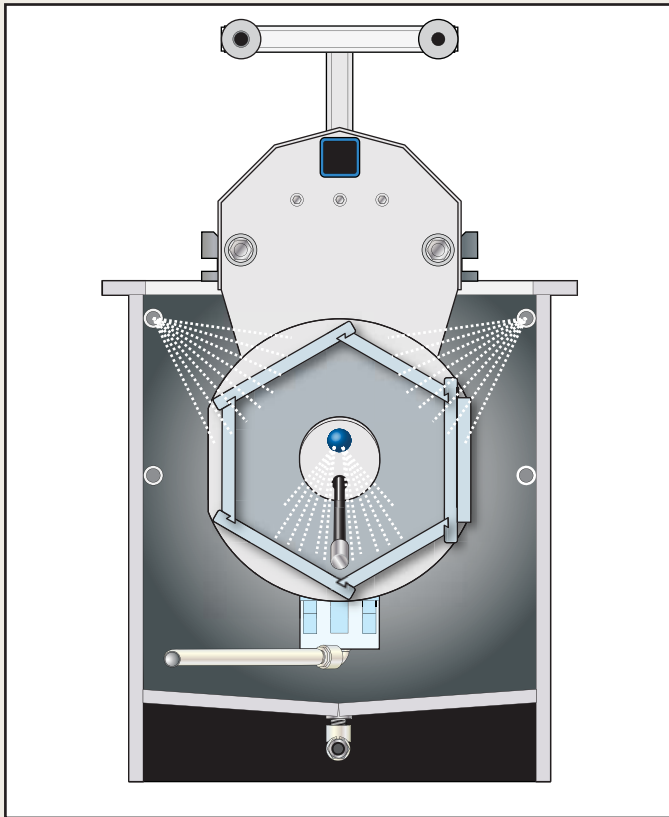

A SprayThru Barrel seated in RinseMaster tank.
The same tank can also be used for Racks.

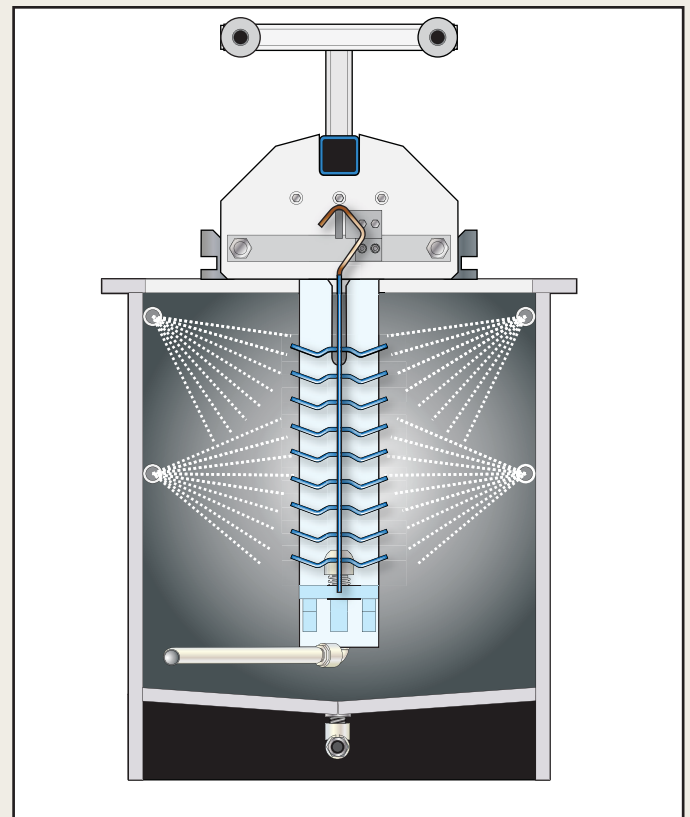

A Rack being rinsed inside a RinseMaster tank.
The same tank can also be used for barrels

Warranty

This equipment is warranted by HARDWOOD LINE MANUFACTURING COMPANY, to the original user for one year following the date of purchase against defects in materials or workmanship when installed and operated according to our instructions and limitations, and when used with approved solutions. We will, at our option, repair or replace any part or assembly proven to be defective when it is returned prepaid to our plant. Pump metal parts (i.e., motors, etc.) are not warranted against corrosion. This warranty is in lieu of any others. We assume no responsibility for consequential damages.

Patent Nos. 4,790,904 - 5,063,949 - 5,139,039 - 5,194,095 & Pending

© HARDWOOD LINE MFG .CO. 3/07

For More Information, Please Call:
800-443-0093



Hardwood Line
MANUFACTURING COMPANY
4045 N. Elston Avenue, Chicago, Illinois 60618
Phone: (773) 463-2600 Fax: (773) 463-9222
e-mail: sales@hardwoodline.com
web site: www.hardwoodline.com

Printed in U.S.A.