

Popup Drink Thru

**BUNN ITCB-DV Manual
and Cleaning**

June 2021

Confidential & Proprietary

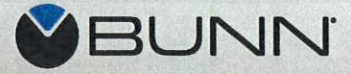

A photograph of a white ceramic teapot pouring tea into a white cup on a saucer. The cup is filled with a golden-brown liquid. In the foreground, a glass coffee cup filled with a dark, frothy beverage is visible. The background features a blue and white patterned fabric with a star and circular motifs.

TEA

Steeping a flawless infusion...

BASICS

SOLVING WATER PROBLEMS

WATER PROBLEMS AFFECTING ICED TEA QUALITY

Water hardness is caused by a high mineral content. Tests show any hardness in excess of 200 ppm can cause clouding in iced tea. Chemical taste and/or odor caused by chlorination of municipal water and the presence of hydrogen sulfide in the water can also detract from tea flavor. In addition, the presence of particulate matter in water can cause scale and lime accumulation, detracting from the operational efficiency of automatic tea steeping equipment.

To minimize problems associated with a less than optimal water supply, the Tea Association recommends installation of filtration/conditioning equipment and water softening equipment to reduce or eliminate water hardness caused by excessive mineral content. In extreme hard water areas, a preventive maintenance service arrangement may be necessary.

Water Hardness Map

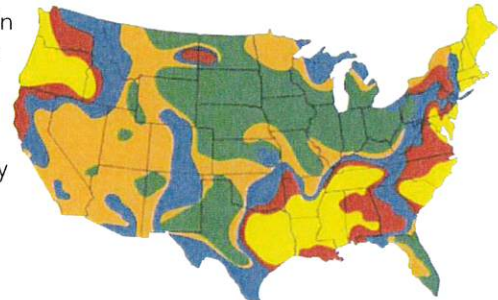

THE IMPORTANCE OF ROUTINE CLEANING

To guarantee your steeping equipment is clean and your customers receive only the best fresh-steeped iced tea, follow these simple steps:

Prepare only enough tea that you expect to sell within 12 hours. Discard any unused tea after 12 hours.

To protect tea flavor and to avoid bacterial contamination and growth, clean and sterilize tea steeping and storage equipment at least once a day as follows:

- Dismantle dispensing spigots, hoses, storage reservoirs (removing gaskets, "O" rings, etc) and rinse in warm water along with other steeping and storage utensils.
- Wash in hot water using a dish detergent. Remove any encrusted soil deposits with a brush or cleaning pad.
- Rinse thoroughly with clean hot water.
- Sanitize non-stainless steel parts by immersing for at least 1 minute in hot water at 180°F (82.2°C) or by rinsing in warm water mixed with chlorine (minimum 50 ppm – one capful of chlorine bleach to one gallon of water). Do not use chlorine bleach on stainless steel urns or dispensers – it will promote small leaks.
- Disassemble dispenser spigot, then clean and sanitize according to manufacturer's directions.
- Replace any worn gaskets, "O" rings, or any other scratched or damaged parts before reassembling.



THE ELEMENTS OF TEA STEEPING

WATER

All tea, both hot and iced, is affected by water quality. Because of tea's light flavor, the quality of input water is crucial to the beverage.



TEMPERATURE

Temperature is critical to tea steeping and varies based on the type of tea being steeped. Recommended steeping temperatures range from 160°F (71.1°C) to 210°F (98.9°C).



TIME

In order for the leaves to unfurl during steeping, tea needs to be exposed to hot water for a certain amount of time. This time will vary depending on the type of tea and the temperature of the water.



Actual steeping times will vary with the preferences of the individual tea consumer.

TEA

Today, iced tea accounts for 75-80 percent of America's tea consumption. Of the more than 240 million pounds of tea packaged for consumption in the United States, over 65 percent comes in tea bags.



CLEANING

To protect tea flavor and to avoid bacterial contamination and growth, the Tea Association of the USA recommends that storage and dispensing equipment for tea be cleaned and disinfected at least once a day. Detailed cleaning instructions are given under "The Importance of Routine Cleaning."



THE ART OF TEA STEEPING

The finished tea will be only as good as the quality of the water source and tea used in the preparation. The Tea Association recommends water filtration of the incoming supply and proper cleaning of all equipment.

At 3 to 45 cents per serving, hot tea can be an excellent low cost/high profit beverage for the foodservice operator. You can realize even more profit from iced tea.

THE TEA STEEPING PROCESS

Heating the water

If you are preparing water for hot tea, you can heat it on the stove or use a hot water dispenser. Bring fresh cold water to the correct temperature for the type of tea being brewed. Never allow water to boil for a long period of time, because it will dissipate the air bubbles and “flatten” the beverage, adversely affecting the taste. Iced tea steep water should be at least 195°F (90.6°C).

Steeping the tea

For single-serve hot tea, if you use tea bags, add one tea bag for each cup of tea you expect to serve. If you are using loose tea, place 1 teaspoon per cup in an infuser.

Temperatures recommended by the Tea Association of the USA for each type of tea:

- **Black tea** – 3-5 minutes at 201-210°F (96.1 – 98.9°C)
- **Darjeeling tea** – 3 minutes at 190-195°F (87.8 – 90.6°C)
- **Oolong tea** – 3-5 minutes at 175-195°F (79.4 – 90.6°C)
- **Chinese green tea** – 1- 3 minutes at 170-180°F (76.7 – 82.2°C)
- **Japanese green tea** – 1 to 2 minutes at 160-175°F (71.1 – 79.4°C)
- **White tea** – 3 to 4 minutes at about 185°F (85°C)



For iced tea, pour one quart of boiling water for each 1 ounce tea bag used over the tea and steep for 3-5 minutes. Minimally, tea leaves should be exposed to water at a temperature of 195 °F (90.6 °C) for approximately 5 minutes. Remove tea bag and add fresh, cold tap water to yield final quantity of iced tea.

If you are using an automatic iced tea brewer, place the tea into the steeping basket and start the steeping cycle. When steeping is finished, stir contents with a sanitized stirrer if steeping equipment is not equipped with an auto-blend feature.

For commercial purposes, “sun” tea is not an acceptable practice for steeping tea.

Serving

As with other beverages, merchandising tea is a vital step. Whether you choose to enhance your iced tea servers with colorful wraps or serve your hot tea in a porcelain teapot, your goal is to entice your customers to buy more of this beverage. An appropriate server also affects the flavor of the beverage. Hot tea should be kept hot and iced tea, cold.

SOLVING WATER PROBLEMS

WATER PROBLEMS AFFECTING ICED TEA QUALITY

Water hardness is caused by a high mineral content. Tests show any hardness in excess of 200 ppm can cause clouding in iced tea. Chemical taste and/or odor caused by chlorination of municipal water and the presence of hydrogen sulfide in the water can also detract from tea flavor. In addition, the presence of particulate matter in water can cause scale and lime accumulation, detracting from the operational efficiency of automatic tea steeping equipment.

To minimize problems associated with a less than optimal water supply, the Tea Association recommends installation of filtration/conditioning equipment and water softening equipment to reduce or eliminate water hardness caused by excessive mineral content. In extreme hard water areas, a preventive maintenance service arrangement may be necessary.

Water Hardness Map

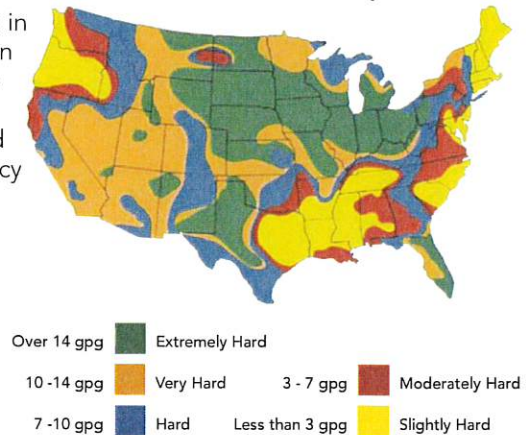

THE IMPORTANCE OF ROUTINE CLEANING

To guarantee your steeping equipment is clean and your customers receive only the best fresh-steeped iced tea, follow these simple steps:

Prepare only enough tea that you expect to sell within 12 hours. Discard any unused tea after 12 hours.

To protect tea flavor and to avoid bacterial contamination and growth, clean and sterilize tea steeping and storage equipment at least once a day as follows:

- Dismantle dispensing spigots, hoses, storage reservoirs (removing gaskets, "O" rings, etc) and rinse in warm water along with other steeping and storage utensils.
- Wash in hot water using a dish detergent. Remove any encrusted soil deposits with a brush or cleaning pad.
- Rinse thoroughly with clean hot water.
- Sanitize non-stainless steel parts by immersing for at least 1 minute in hot water at 180°F (82.2°C) or by rinsing in warm water mixed with chlorine (minimum 50 ppm – one capful of chlorine bleach to one gallon of water). Do not use chlorine bleach on stainless steel urns or dispensers – it will promote small leaks.
- Disassemble dispenser spigot, then clean and sanitize according to manufacturer's directions.
- Replace any worn gaskets, "O" rings, or any other scratched or damaged parts before reassembling.

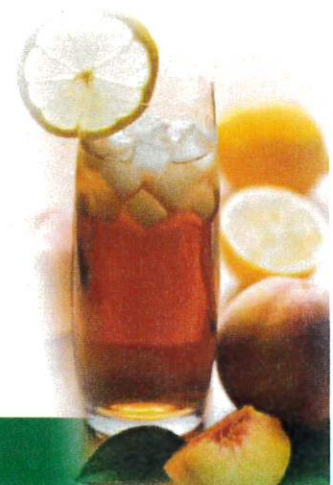

A FLAWLESS INFUSION YOUR CUSTOMERS CANNOT FORGET

A soothing potion or a bracing beverage. The perfect concoction of subtle flavors or a mouth-watering pick-me-up on a steaming day. Multi-faceted, aromatic and flavorful. Flawless tea starts with the tea leaves slowly unfurling in steeping, and ends as your patron savors a perfect cup of tea.

THE ART OF SELECTING TEA

TYPES OF TEA

Black teas are withered, rolled, fully oxidized and dried.

Flavored teas are usually black but could be any teas with flavor added.

Oolong teas are partially oxidized and feature leaves that are withered, rolled, partially oxidized and dried.

Green teas are not allowed to oxidize and their leaves are steamed, rolled and dried.

White teas are very rare and produced predominately in China. White tea is actually defined by a process which lacks the rolling stage of usual tea production.



GRADES OF TEA

As a part of their processing, tea leaves go through sieves with graduated mesh to sort them for commercial sale. These sieves divide them into three grades: **leaf, broken, and fines.**

Leaf grades are made up of the larger leaves left after the broken grades have been sifted out.

In orthodox manufacture, **broken** grades made up of smaller and broken leaves represent roughly 80 percent of the total crop.

The name for the smallest grade produced is **Fines (Dust)**. This grade is very useful for a quick brewing, strong cup of tea.

Tea selection and steeping information provided by the Tea Association of the USA.



BUNN AND TEA

For hot tea, iced tea – or both – choose BUNN equipment. Besides creating traditional fresh-brewed tea, BUNN equipment offers operators the choice of single cup brewing or of making tea from concentrate.

SERVE HOT TEA EASILY

Precision Temperature Water Dispensers – a great way to have the right temperature water instantly for your tea. BUNN hot water dispensers can dispense 2-10 gallons and a pourover model is also available (OHW).

Single Cup Brewing – a single cup of wonderful tea is no problem with the AutoPOD Brewer. This tiny dynamo can preinfuse tea with water so that the tea leaves have the appropriate amount of contact time to water, then pulse brew for perfect steeping.

THE ANSWER TO YOUR ICED TEA QUESTIONS

Before 1978, when George Bunn introduced the first iced tea brewer to the foodservice industry, there were very few options for those who wanted to serve fresh iced tea. But that's all changed... here are some of the many BUNN iced tea brewers.

Fresh Brewed Iced Tea with the TB3 – available in regular, quick-brew and low-profile models, all the tea brewers will brew 16.3 to 26.7 gallons (61.7 to 101.1 litres) per hour of tea from real tea leaves. The three-gallon brewers (TB3, TB3Q) brew into any style server that can hold up to 4 gallons. Choose from a variety of servers to meet your needs.

Tea Concentrate Offers Another Option – Using tea concentrate reduces the amount of time necessary to serve iced tea. For many foodservice establishments, tea concentrate is the perfect solution. The Tea Concentrate Dispenser (TCD-1 or TCD-2) offers another option for these environments.

Hot Tea, Iced Tea – Serve Them Both with the ITCB – Leave it to the company that introduced the commercial iced tea brewer to come up with a brewer that will make both hot and iced tea (and hot coffee too). Ideal for use where space is limited, the Infusion Series® Tea and Coffee Brewer incorporates BrewWISE® precision and simplicity into a tea brewer.



5020 Ash Grove Drive, Springfield, IL 62711 USA
(800) 637-8606 | +1 (217) 529-6601 | www.bunn.com



BUNN® TECHNICAL TRAINING

ITCB



Index

Unit 1: Installation

Site Requirements	4
Location of the Serial Number	4
Water Supply Install	4
Electrical Install	5
Initial Start-Up	5

Unit 2: Setup

Setup and Programming	7
Programming Lockout	7
Level 1 Programming	7
Level 2 Programming	8
Uploading a Recipe Using a Recipe Card	10
Calibrating the Sprayhead Flow Rate	10
Calibrating the Dilution Flow Rate	11
Default Values	11

Unit 3: Machine Composition

Exterior Overview	13
Product Outlets and Removable Parts	13
User Interface	13
Accessing the Inside of the Brewer	13
Machine Function and Operations	13
Main Control Board	13
Filling System	14
Heating System	14
Dispensing System	14
Dilution System	15

Unit 4: Preventive Maintenance

Preventive Maintenance	17
Draining the Tank	17
PM Steps	17

Unit 5: Troubleshooting

Service Tools	20
Test Outputs	20
Test Switches	21
Test Frequency	21
Service Fault Messages	21
Triac Map	22

UNIT 1 INSTALLATION

Unit Objectives

Given a realistic scenario depicting a new site install, the learner will be able to install and setup the brewer for retail turnover without error.

Given a new machine, all the necessary tools and safety equipment, the learner will be able to install the brewer without error.

The learner will be able to verify that the site requirements have been met.

The learner will be able to locate and document the serial number.

The learner will be able to hook up the water supply.

The learner will be able to hook up the electrical supply.

Installation

Site Requirements

Space

- Height clearance for either 30.87" or 34.04" depending on model
- Footprint able to accommodate 11W x 24D
- Counter able to support 100lbs. (operating weight of the brewer with a full 5 gallon tea server)
- Level installation surface, brewer level on the surface

Water Treatment

- Sediment filtration to reduce large particles
- Taste and odor filter to remove chlorine
- Scale filtration as needed
- For best results a Bunn Easy Clear® filtration system should be used

Plumbing

- .75-11.5 NH (hose thread) fitting (¼" flare adapter included)
- Dedicated water supply with shut-off
- Connected to the cold water supply
- Water pressure 20-90psi
- Minimum water flow of 1.25GPM

Electrical (120VAC)

- 120VAC
- 2-wire plus ground (L1, neutral, ground)
- 15 amp dedicated circuit (breaker, plug, and receptacle)
- Receptacle within 5 feet of the machine

Electrical (208VAC or 240VAC)

- 120/208VAC or 120/240VAC
- 3-wire plus ground (L1, L2, neutral, ground)
- 20 amp dedicated circuit (breaker, plug, and receptacle)
- Receptacle within 5 feet of the machine

Location of the Serial Number

The machine's serial number is located on the data plate which is adhered to the front panel below the dilution nozzle. The complete serial number will need to be documented on all work orders and warranty tags. The serial number is also stored in memory on the control board.

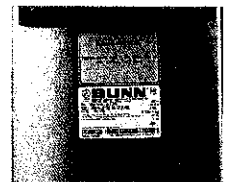

Water Supply Install

Step 1: Remove the shipping cap from the fitting on the rear of the brewer.

Step 2: Install the .75-11.5 NH to ¼" flare adapter on the rear of the brewer; be sure to use the included rubber washer.

Step 3: Flush the water line.

Step 4: Attach the water line to the ¼" flare fitting on the back of the machine.

Step 5: Turn on the water supply.

Electrical Install

An electrician must provide electrical service as specified in conformance with all local, state, and federal electrical codes.

The ITCB is a dual voltage unit. There is a voltage switch located on the back of the brewer. The brewer is wired from the factory with a 2-wire+ground power cord and plug rated for 120VAC at 15amps. For 208VAC or 240VAC configurations, the 3-wire+ground power cord must be ordered from BUNN: P/N: 01699.0000. The technician must supply a 20amp rated, 4-wire plug.



For 120V brewers:

Step 1: Plug brewer into the power source.

For 120/208VAC or 120/240VAC brewers:

Step 1: Remove the rear panel.

Step 2: Disconnect the 2-wire+ground cord from the terminal block.

Step 3: Feed the 3-wire+ground power cord through the strain relief.

Step 4: Attach the wire ends to the terminal block.

Step 5: Attach the ground wire to connector below the terminal block.

Step 6: Check that all connections are tight.

Step 7: Place the dual voltage toggle switch in the correct position.

Step 8: Tighten the strain relief and replace the rear panel.

Step 9: Plug the unit into the power source.

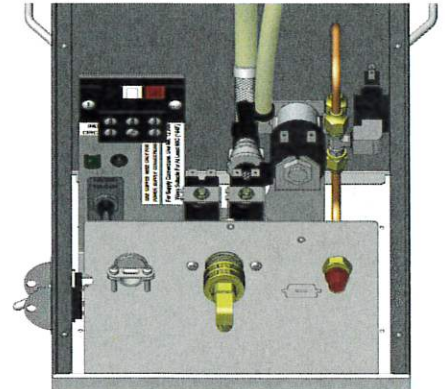

Initial Start-Up

Step 1: Place the main power switch into the On position.

When the machine is turned on and the Enable Brew On/Off switch is pressed, it will begin to fill the tank.

**PLEASE WAIT
TANK FILLING**

After the tank fills the machine will automatically begin the heating cycle. This will take approximately 20 minutes.

**HEATING
WATER TEMP XXXX°**

Once the water temperature has reached the programmed Brew Lockout temperature it will display the ready screen. The machine will continue to heat until it reaches its programmed shut-off temperature.

**READY TO BREW
WATER TEMP: 205°**

UNIT 2 SETUP

Unit Objectives

Given a realistic scenario depicting a new site install, the learner will be able to install and setup the brewer for retail turnover without error.

Given an installed machine, all the necessary tools and safety equipment, the learner will be able to set the machine up for initial operation.

The learner will be able to power on the machine.

The learner will be able to access and scroll through the programming options.

The learner will be able to perform the calibrations.

Setup and Programming

Accessing and using the brewer's programming features is done from the front panel and requires no special tools.

The programming menu is accessed through a hidden switch located on the right side of the display. The hidden switch on the left side will allow you to scroll backwards.

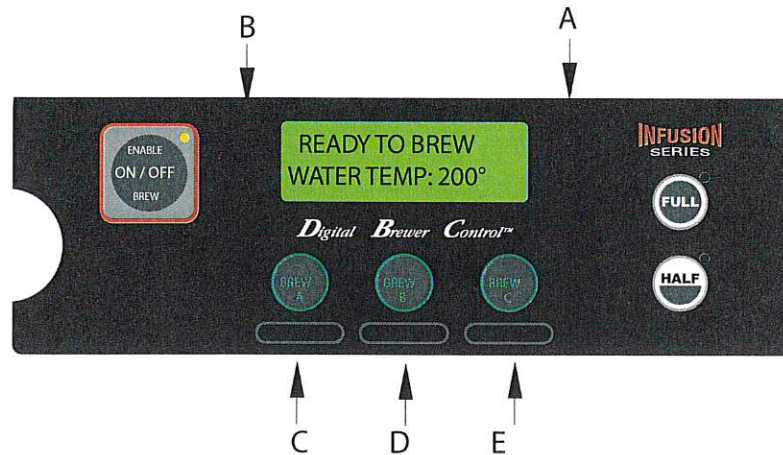

A. Right Hidden Switch: This is used to access the programming mode and is also used to scroll forward through the function list.

B. Left Hidden Switch: This is used to scroll backwards through the function list.

C. Brew A: This is used to select options that appear on the display during programming.

D. Brew B: This is used to select options that appear on the display during programming.

E. Brew C: This is used to select options that appear on the display during programming.

To exit the programming mode at any time, press and release the ON/OFF button located on the user interface. The display will return to the main screen.

Programming Lockout

If the programming cannot be access then the programming lockout switch is in the Lock position. The switch is located on the control board. Remove the top panel, locate the switch and place it into the Unlock position.

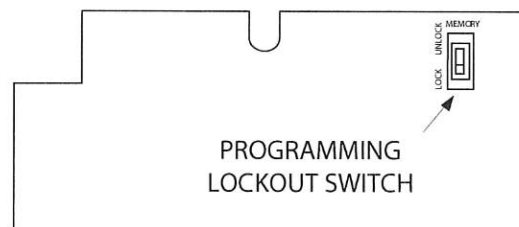

P3048

Note: Prior to serial number ICB00007479, the lockout switch will be located on the memory module board.

Level 1 Programming

Press the hidden switch for one second to access.

BREW LOCKOUT ?
ON DONE OFF

This function allows the operator to prevent or allow brewing if the water temperature is less than the Set Ready temperature.

Level 2 Programming

Press and hold the hidden switch for 5 seconds

Set Language?

NO YES

This function allows the operator to select the language used for the display.

UNITS

Metric DONE ENG

This function allows the operator to select if numeric settings are displayed in English or Metric units.

REVIEW RECIPES ?

NO YES

This function allows the operator to view the brew settings for the various coffee recipes stored into the brewer. It also allows the operator to modify any of the brew settings for a particular recipe stored in the brewer.

ASSIGN RECIPE ?

NO YES

This function allows the operator to assign a recipe to (or disable) each of the 3 brew switches (A, B, C). Any saved recipes listed under "Review Recipes" can be assigned to a brew switch. Only one recipe per brew switch is allowed.

SET NEW RECIPE ?

NO YES

This function allows the operator to set Brew Volumes, Bypass %, Pulse Brew/Preinfusion Times and Drip Out Times for each coffee name stored in the grinder's memory.

MASTER TEMP 205°

(-) DONE (+)

This function allows the operator to adjust the brew water temperature in the tank. This also sets the hot water faucet dispense temperature.

READY DEGREE 5°

(-) DONE (+)

This function allows the operator to set the minimum temperature allowable to start a brew cycle. The range can be from 2° to 20° F below the set temperature. The water must be at the Ready temperature or higher for the display to indicate Ready To Brew. If brew lockout is enabled, the brewing process won't start below this Ready temperature.

ENABLE ADS ?

NO DONE YES

This function allows the operator to choose whether or not to display an advertising message. An ad can be saved to the brewer by either writing the ad using the programming commands, or by entering the ad into the brewer using an Ad Card. This message will be displayed when the brewer is not in use.

ENABLE SANITATION

NO DONE YES

This function allows the operator to enable the sanitation function and set the time before a cleaning alert will be displayed.

ENABL ENERGYSAVR

NO DONE YES

This function allows the operator to enable the Energy Savings mode function and set the idle time. Once the set idle time has expired, the operator can choose to have the heaters either turn off, or reduce the tank holding temp to 140° F (60° C).

ENABLE FRESH TIMER

NO DONE YES

This function allows the operator to enable the Freshness Alert and set the expiration time. The expiration time is the amount of time the product is allowed to sit in the server/dispenser before a fresh batch is brewed.

XX REFILL XXX
(-) DONE (+)

This function allows the operator to adjust the sensitivity of the refill circuit. This is mainly a troubleshooting feature. Water in different geographical locations can have different conductivities. By adjusting the sensitivity of the refill circuit, this will allow the brewer to operate under various water conditions.

SPRAY OZ/M: XX.X
(-) DONE (+)

This function allows the operator to view or enter the actual flow rate coming out of each sprayhead. This is Not used to control the actual flow rate, but to tell the internal processor how fast the water is flowing.

DILUTE OZ/M: XX.X
(-) DONE (+)

This function allows the operator to view or to enter the actual flow rate coming out of the dilution nozzle. This is not used to control the actual flow rate, but to tell the internal processor how fast the water is flowing.

CALIBRATE FLOW?
NO YES

This function allows the operator to test and enter the actual flow rate of the sprayhead(s) and the bypass/dilution for each side of the brewer by dispensing each separately for one minute. The volumes are then entered into the brewer.

BREW COUNTERS?
NO YES

This function allows the operator to track the total number of brew cycles completed, as well as the number of batches brewed using each of the brew buttons. There are (up to) three resettable counters, and one life counter that is not resettable.

SET RECIPES TEMPS
NO YES

This function allows the operator to set separate temperatures for each selected recipe.

ENTER ASSET #
NO YES

This function allows the operator to enter the machine's asset number. This can be useful for tracking the usage or service of an individual machine within a group.

ENTER SERVICE #
NO YES

This function allows the operator to enter in the telephone number to call if service is needed. The service number will be displayed anytime there is a fault message displayed.

SERVICE TOOLS
NO YES

(For Authorized Service Personnel Only)

This function allows the testing of individual components and the ability to check switches for proper function. This function also tests the funnel sensor coil's frequency (diagnostic tool for troubleshooting purposes only). Refer to Service Manual for in depth procedures.

FACTORY DEFAULTS
NO YES

This function allows the operator to erase **all** of the previously entered recipes and ad messages. Factory-set default values will replace All previous settings.

Uploading a Recipe Using a Recipe Card

The recipe card includes all the information needed to set up that particular tea/coffee name. The information from the recipe card is loaded into the brewer's memory by holding the chip area up to the brewer's sensing coil. This information can include all the recipe settings for that particular name. These can all be loaded in seconds.

Note: Instructions to program the brewer are printed on the recipe card, along with the tea or coffee name that is being programmed.

Procedure to program the coffee name:

Step 1: Remove the funnel.

Step 2: Position the recipe card vertically, so that the top end of the chip is beneath the sensing coil (located on the under side of the front panel).

Step 3: After a short pause the display will read "Card Contains Recipe For" then will change to "Recipe Name" (SHOW-QUIT-SAVE). All brewing parameters for that recipe are now transferred from the card to the brewer.

Step 4: To show (view) this information, press and release SHOW. The display will scroll through all of the brew settings for that recipe. This display will then return to "Card Contains Recipe For" then will change to "Recipe Name" (SHOW-QUIT-SAVE).

Step 5: If all brew settings are correct, press SAVE. The display will read "Recipe Name Setup Complete". All brew settings for that name are now stored in the Brewer's memory.

Step 6: If the brewing information is not correct, or it is desired to exit the setup before the settings are loaded into the brewer's memory, press QUIT. The display will read "Recipe Name Not Saved". The display will then return to the main screen.

Note: This just saves the recipe in the brewer's memory. To use for brewing, you must still assign the recipe to a brew button.

Calibrating the Sprayhead Flow Rate

Step 1: Place a measuring container with a minimum capacity of 60 ounces beneath the funnel of the brewer. Water can also be dispensed into the server and then into the measuring container.

Step 2: Press and hold the right hidden switch to enter level 2 programming. Continue to press the right hidden switch until the display reads "Calibrate Flow?".

Step 3: Press YES to advance to the "Spray Head Cal?" function screen.

Step 4: Press YES. The display will read "Container Ready?" If the container is under the funnel, press YES. The display will read "Calibrate Spray... Press Brew to Start".

Step 5: Press and release the BREW switch (on the side to be calibrated for Dual Brewers). The display will read "Calibrate Spray...60 Sec to Finish". The 60 second timer on the display will count down to zero. When the counter reaches zero, the display will change to OZ, along with the existing ounces per minute.

Step 6: Measure the amount of water in the container and using the (-) or (+), adjust the amount on the display to match the amount in the container. Then press DONE.

Step 7: The display should now read "New Spray Flow" along with the correct flow rate of the sprayhead in ounces per minute. After 5 seconds, the display will return to the "Calibrate Flow?" screen.

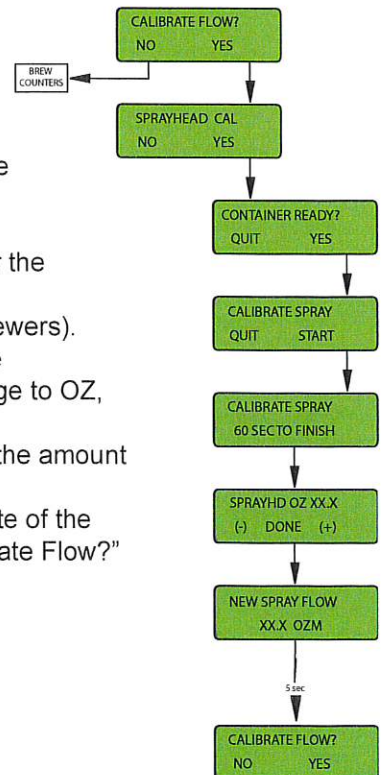

Calibrating the Dilution Flow Rate

Step 1: Place the measuring container with a minimum capacity of 130 ounces beneath the dilution nozzle on the brewer. Water can also be dispensed into the server and then into the measuring container.

Step 2: Press and hold the right hidden switch to enter level 2 programming. Continue to press the right hidden switch until the display reads "Calibrate Flow?".

Step 3: Press and release YES to advance to the "Sprayhead Cal?" function screen.

Step 4: Press and release NO to advance to the "Dilution Calibration" screen.

Step 5: Press YES. The display will read "Container Ready?" If the container is under the nozzle, press YES. The display should read "Calibrate Dilute .. Press Brew to Start".

Step 6: Press and release the BREW switch. The display will read "Calibrate Dilute... 60 Sec to Finish". The 60 second timer on the display will count down to zero. When the counter reaches zero, the display will change to "Dilute OZ/M" along with the existing ounces per minute.

Step 7: Measure the amount of water in the container and using the (-) or (+), adjust the amount on the display to match the amount in the container. Then press DONE.

Step 8: The display should now read "New Dilute Flow" along with the correct flow rate of the bypass in ounces per minute. After about 5 seconds, the display will return to the "Calibrate Flow?" screen.

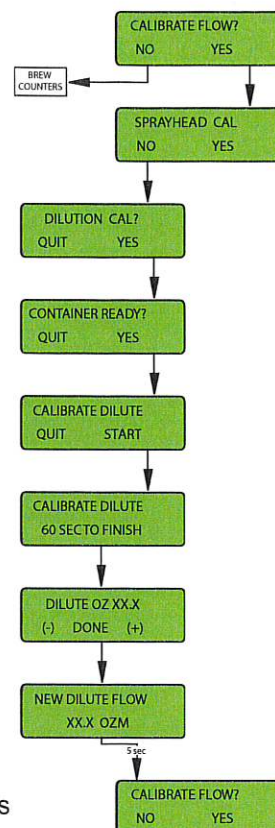

Master Tank Temp

The Master tank temperature is the maximum temperature for the tank. The Set Recipe Temps allows the operator to set temperature for all recipes and will override the Master temp.

Explanation:

Setting recipe temps will override the Master Temp. The tank will hold at the lowest temperature between the three selected recipes stored in the brew buttons. For instance, let's say Brew A's recipe temperature is set at 205°, Brew B's recipe temperature is set at 205°, and Brew C's recipe temperature is set at 200°. The tank will hold at 200°. If Brew A or Brew B is pressed, the tank will heat to the 205° temperature. The brew button must be pressed again in order for a brew to start. After the completion of that brew, the tank will return to the 200° holding temperature. It may take awhile for the tank to return to the lower temperature.

Factory Default Values

Brew Lockout	Disabled
Set Language	English
Units	English
Master Temp	205°
Ready Degree	5°
Enable Ads	Disabled
Enable Sanitation	Disabled
Enable EnergySavr	Disabled
Enable Fresh timer	Disabled
Refill	155
Spray Oz.	24.0
Dilution Oz.	71.0
Set Recipe Temps	Coffee: 200°/Tea: 205°

UNIT 3 MACHINE COMPOSITION

Unit Objectives

Given a realistic scenario in which the learner has access to the machine's internal components the learner will understand the composition and functions of the brewer.

Given a realistic scenario requiring the learner to access the internal components of the machine the learner will be able to remove rear panel and top panel.

The learner will remove the rear panel and top panel.

Given an operating machine the learner will be able to give a general explanation of how the unit operates.

The learner will be able to identify the functions of the main control board .

The learner will be able to identify the components and functions of the filling system.

The learner will be able to identify the components and functions of the heating system.

The learner will be able to identify the components and functions of the dispensing system.

The learner will be able to identify the components and functions of the dilution system.

Machine Composition

Exterior Overview

Product Outlets and Removable Parts

- User interface (A)
- Display (B)
- Hot water outlet (C)
- Sprayhead (D)
- Dilution Nozzle (E)
- Funnel sensing coil (F)
- Data plate (G)
- Flip down tray (H)
- On/off switch (on the side)

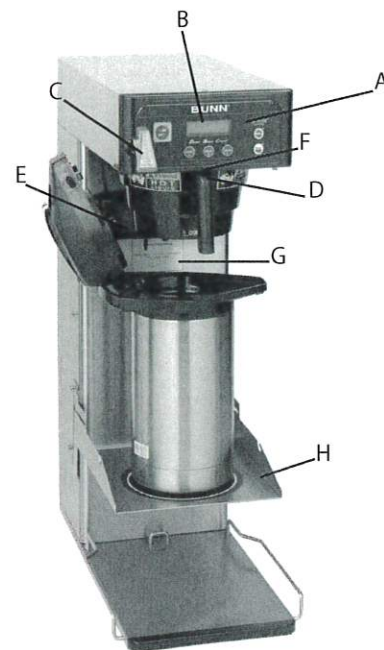

User Interface

The user interface is a membrane switch adhered to the front of the brewer. The membrane is connected to the control board by a ribbon cable. The user interface allows the user to select the product, batch size and to begin the brew cycle.

The machine's display is mounted to the control board. The display is visible on the front of the machine and provides information to the user and to the technician.

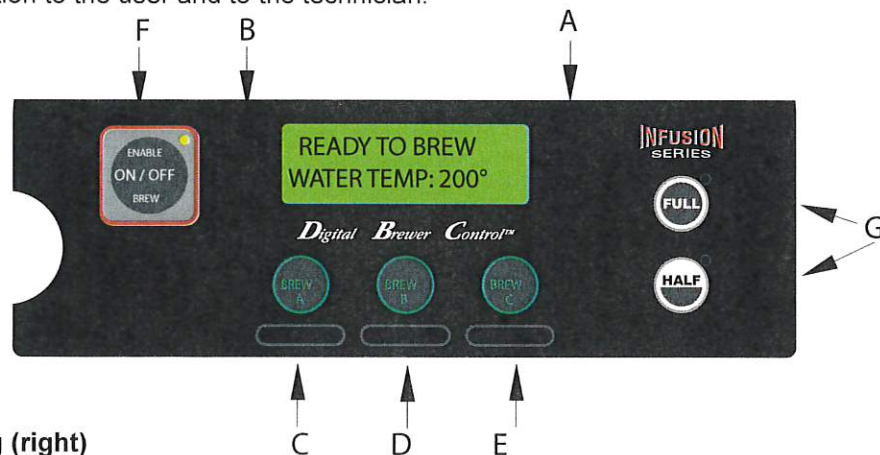

A. Programming (right)

Pressing and holding this pad allows entry into the programming menus. Pressing and releasing the pad steps through each function screen while in the programming mode.

B. Programming (left)

This hidden pad can be used to scroll backwards through the function list while in programming mode.

C, D, E. Brew (A, B, C) and Function

When the ON/OFF is ON and the brewer is on the main screen (not in programming mode), momentarily pressing and releasing this pad will begin a brew cycle. These are also used to program the brewer when in the programming mode.

F. On/Off Switch

Pressing the "ON/OFF" pad will alternately turn the brewer on and off. Pressing this pad during the brew cycle will interrupt the brew cycle, stopping the flow of water. Pressing this pad during programming of the brewer will exit the setup and return to the main screen.

G. BATCH SELECTOR PADS

Pressing the pad corresponding to the Half or Full batch selects the amount of product to be brewed. Pressing a different pad after a brew cycle has been initiated does not change the brew batch in progress. Light indicates the selected batch to brew. Also used in programming to adjust settings on both batch sizes.

Accessing the Inside of the Brewer

The majority of service work to the ITCB brewer will require the removal of either the rear panel or the top panel. The top panel is secured with 1 flathead screw. The rear panel is secured with either 6, 7 or 10 flathead screws, depending on the age of the machine.

Machine Function and Operations

Main Control Board

The main control is the brain of the brewer. In the Digital Brewer Control (DBC®) system, the control board is the single component that contains all of the programming software, it interprets all the data it receives from the level and temperature sensors and activates components to fulfill those demands. The main control board responds to the users input through the membrane switch and activates and controls the brew cycle. The control board can receive data from Smart Funnels® through a sensing coil on the front of the machine.

In a digital tea brewer the control board takes the place of the liquid level control board, the timer board, the dilution timer and the mechanical thermostat. All of these components are combined into a single unit.

Filling System

The fill system maintains the level of water in the brewer's tank. Anytime water is drawn off of the tank during a brew cycle or from the hot water outlet, the fill circuit activates to refill the tank.

The fill system consists of:

- 120VAC solenoid inlet valve
- Flow control
- Fill probe

Water enters the rear of the brewer from the supply line and first goes through a plastic strainer mounted in the combination inlet solenoid/dilution solenoid assembly. From the solenoid valve the water flows through a .50 gallon per minute flow control washer and then into the bottom of the water tank.

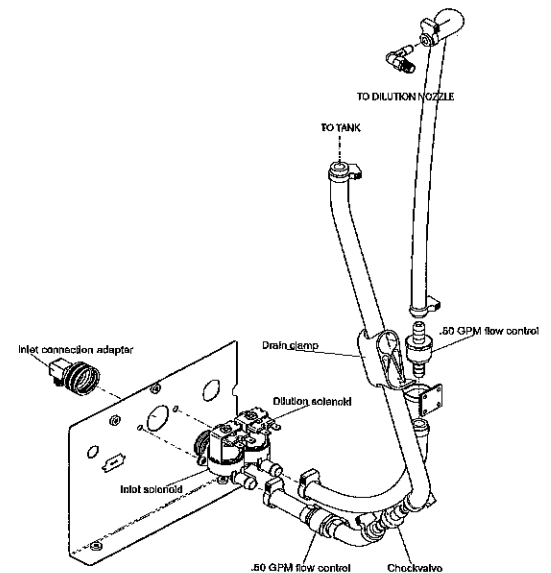

The 120VAC solenoid inlet valve is activated by the control board anytime the brewer calls for water. The valve opens and allows water to flow, under line pressure, to the tank where the silicon tube connects to a fill tube attached to the tank.

The control board monitors the level of water in the tank through a low voltage level probe mounted to the top of the tank. The control board grounds a 2.5VAC signal to the tank through the water. If it loses this signal, the control board will activate the inlet valve.

Heating System

The heating system consists of:

- Water tank
- Heating elements
- High-limit thermostats
- Temperature sensor
- DV switch

The heating circuit maintains the water in the tank at a preset temperature this ensures that the water is always ready for brewing.

Water for brewing is contained in a 200 ounce stainless steel tank. This tank contains a 1680W @ 120VAC heating element that is powered by the line voltage into the machine. The heating element is controlled by the control board through a mechanical relay. The dual voltage ITCB brewer adds an additional 1800W for 208/240VAC heating element; the two elements are wired in series.

The control board monitors the water in the tank by a temperature sensor that is in contact with the water. This temperature sensor is a digital thermistor; the control board reads the temperature as value of resistance. The temperature sensor allows the control board to trigger the heating element triac when the temperature drops below its programmed value and shut down the trigger voltage when the water temperature reaches the programmed holding value.

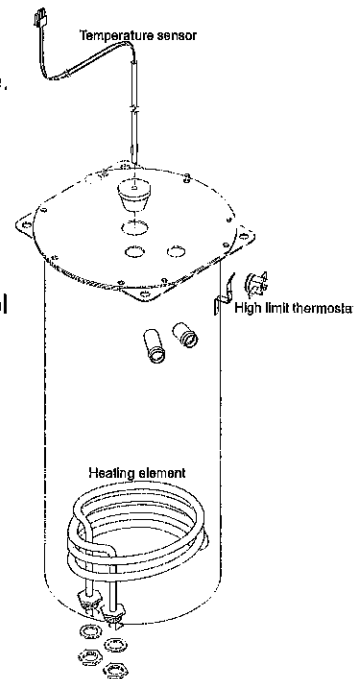

Dispensing System

The dispensing system consists of:

- Dispense valve
- Sprayhead
- Funnel

The ITCB brewer is a gravity dump brewing system. During the brew cycle the dispense valve will open allowing water to flow from the tank to the sprayhead. The dispense solenoid is 120VAC valve. The sprayhead not only serves to diffuse the water over the product but also serves as the outlet flow control.

For coffee brewing the ITCB can be programmed with pulse brew routines. The control board will open and close the dispense valve multiple times during the brew cycle.

Because the ITCB can brew both coffee and tea it can accept multiple funnels. For tea brewing the funnel will have a small outlet restrictor to facilitate the water have a longer contact time with the tea (steeping) and a strainer screen to prevent tea leaves from following to the server. For coffee brewing the ITCB can accept a standard coffee funnel or a Smart funnel.

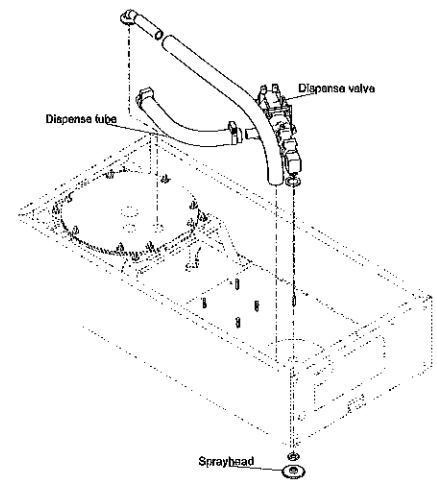

Dilution System

The dilution system consists of:

- Dilution valve
- Flow regulator
- Dilution nozzle

The ITCB features quick brew by default, but a delay can be programmed. The brewer will dump water directly into the tea server to dilute the tea concentrate during the tea brew cycle. The dilution solenoid is a 120VAC valve mounted onto the same body as the inlet solenoid. During a tea brew cycle, the dilution solenoid will open; water will flow through a .50GPM flow control washer and out of the dilution nozzle.

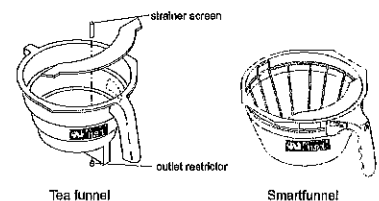

UNIT 4 PREVENTIVE MAINTENANCE

Unit Objectives

Given a realistic scenario depicting a machine requiring a preventive maintenance, the learner will be able to identify which elements of a component need to be serviced without error.

Given a machine, all the necessary tools and safety equipment, the learner will be able to identify the components that need to be serviced for the PM.

In order to maintain proper operation and long service life BUNN recommends performing the preventative maintenance every 6 months. Individual customers will vary with some customers choosing not to receive preventative maintenance.

Tools Required:

- Flat blade screwdriver
- Channel lock pliers
- Needle nose pliers
- Delimiting tool (BUNN P/N: 38227.0000)

Prior to servicing the brewer:

- Disconnect the electrical supply
- Shut off the water supply
- Remove the top panel
- Drain the tank (see below)

Draining the Tank

Step 1: Use a flat blade screwdriver to remove the 7 or 10 screws securing the rear panel onto the chassis, remove the panel.

Step 2: Locate the hose clamp on the fill tube, and clamp off the water line.

Step 3: Remove the clip securing the bottom end of the fill line to the check valve and remove the line from the check valve.

Step 4: Place the water line over a sink or bucket and remove the hose clamp to allow the tank to drain.

PM Steps

Step 1: Disassemble and clean the strainer assembly:

- Use Channel lock pliers to remove the 1/4" flare to 3/4" hose thread adapter fitting from the water inlet assembly
- Use needle nose pliers to gently pull the strainer straight out.
- Rinse the mesh screen to remove any debris build-up.
- Reassembly is the opposite of disassembly.

Step 2: Remove and clean the temperature sensor:

- Gently pull the temperature sensor from the grommet in the top of the tank.
- Wipe any mineral build-up from the probe.
- Reinstallation is the opposite of removal.

Step 3: Remove and clean the fill probe:

- Gently pull the fill probe out of the grommet .
- Wipe any mineral deposits off of the probe.
- Reinstallation is the opposite of removal.

Step 4: Remove and clean the sprayhead:

- Using the pointed end of the delimiting tool, remove any mineral build-up from the sprayhead outlet holes.
- Clean sprayhead fitting

Step 5: Rebuild the dispense solenoid:

- Remove the hose clamps that secure the tubing to the valve.
- Remove the two nuts that hold the solenoid bracket to the machine.
- Gently remove the tubing from the valve body.
- Using a flat blade screwdriver, remove the four screws and separate the valve assembly.
- Replace plunger, spring, and rubber seat using the rebuild kit BUNN P/N: 11517.0008.
- Clean any mineral build-up from the valve.
- Reassembly is the opposite of disassembly.

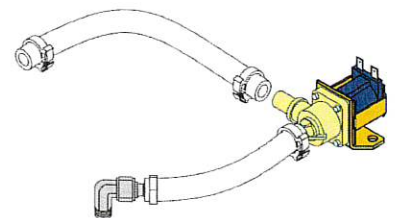
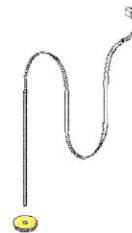

Step 6: Replace the seat cup in the hot water faucet:

- Unscrew the faucet bonnet from the assembly.
- Remove the old faucet seat cup.
- Install the new seat cup BUNN P/N: 02766.0000.
- Reassembly is the opposite of disassembly.
- Visually examine the power cord for any damage.
- Visually examine the water supply for any leaks.

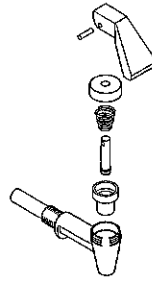

Step 7: Clean the funnel:

- Unscrew the outlet tip and remove the tip and screen.
- Sanitize the tip, screen, and funnel with warm water and sanitize solution.

Step 8: Replace the tea server seat cups:

- Drain the server.
- Unscrew the faucet handle.
- Remove and replace the seat cup.



Step 9: Calibrate the sprayhead and dilution flow rates.

UNIT 5 TROUBLESHOOTING

Unit Objectives

Given a realistic scenario depicting a broken machine, the learner will be able to effectively troubleshoot, diagnosis, and repair the problem returning the machine to normal operation.

Given a machine displaying an error message, all the necessary tools and safety equipment, the learner will be able to diagnosis the problem.

Given a list of error messages and issues, the learner will be to identify the probable cause of the message or issue.

Given a brewer with a defective component, the learner will be able to test the component to determine the cause of the defect.

Service Tools

The ITCB brewer features on-board troubleshooting. Since all of the machine's components are controlled or activated by the control board you can activate and test components individually from the user interface. This allows you to listen to solenoid valves opening, observing the flow of water or test to see if a component is receiving voltage using a meter.

The Service Tools option is located in Level 2 of the programming. Enter level 2 programming by pressing and holding the right hidden switch for 5 seconds. Use the right hidden switch to scroll to the Service Tools Screen.



Press the Brew C button to select Yes. This will enter the Service Tools feature.

In the Service Tools selection there are 3 screens available, by selecting Yes, you will enter that test function, by selecting NO you will move to the next test.

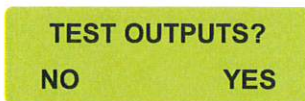

Outputs- Test Outputs supplies voltage to load components in the brewer

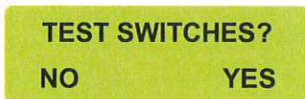

Switches- Tests the inputs from the membrane switch



Frequency- Indicates the transmit frequency of the funnel sensing coil

Test Outputs

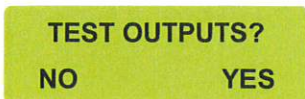

The following components can be tested individually:

- Brew valve
- Dilution valve
- Refill valve
- Tank heater triac
- Sweetener valve

Test Switches

TEST SWITCHES?

NO YES

Press any of the input buttons on the membrane switch, the display will show which button is being pressed.

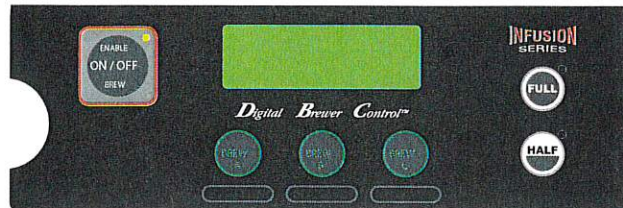

Test Frequency

TEST FREQUENCY?

NO YES

The funnel sensing circuit is tuned to 125 kHz. If the circuit is not tuned correctly, then the funnel information will not be transferred to the brewer. Therefore, the microprocessor is constantly fine tuning to get as close as possible to 125 kHz. It has eight possible tuning steps numbered 0 - 7. When you look at the "TEST FREQUENCY" screen you see something like (124.7 KHZ .5) The 124.7 is the frequency, and the 5 is the tuning step. The decimal point next to the 5 indicates the funnel is being detected; if the funnel is removed the decimal point should turn off.

Service Fault Messages

The brewer features several error messages for problems occurring within the machine. These error messages will show up on the display.

HEATING TIME
TOO LONG

This message will be shown if the control board does not see the programmed water temperature with 60 minutes.

FILL TIME TOO
LONG

This message will be shown if the control board does not see the tank fill within 30 minutes.

TEMP SENSOR
OUT OF RANGE

This message will be shown if the control board loses contact with the temperature sensor or senses a short in the connection.



ITCB Calibrating the Dilution Flow Rate



This function allows the operator to test and enter the actual flow rate of the bypass/dilution.

- Step 1:** Place the measuring container with a minimum capacity of 130 ounces beneath the dilution nozzle on the brewer. Water can also be dispensed into the server and then into the measuring container.
- Step 2:** Press and hold the right hidden switch to enter level 2 programming. Continue to press the right hidden switch until the display reads "Calibrate Flow?".
- Step 3:** Press and release YES to advance to the "Sprayhead Cal?" function screen.
- Step 4:** Press and release NO to advance to the "Dilution Calibration" screen.
- Step 5:** Press YES. The display will read "Container Ready?" If the container is under the nozzle, press YES. The display should read "Calibrate Dilute .. Press Brew to Start".
- Step 6:** Press and release the BREW switch. The display will read "Calibrate Dilute.... 60 Sec to Finish". The 60 second timer on the display will count down to zero. When the counter reaches zero, the display will change to "Dilute OZ/M" along with the existing ounces per minute.
- Step 7:** Measure the amount of water in the container and using the (-) or (+), adjust the amount on the display to match the amount in the container. Then press DONE.
- Step 8:** The display should now read "New Dilute Flow" along with the correct flow rate of the bypass in ounces per minute. After about 5 seconds, the display will return to the "Calibrate Flow?" screen.



ITCB Calibrating the Sprayhead Flow Rate



This function allows the operator to test and enter the actual flow rate of the sprayhead(s).

- Step 1:** Place a measuring container with a minimum capacity of 60 ounces beneath the funnel of the brewer. Water can also be dispensed into the server and then into the measuring container.
- Step 2:** Press and hold the right hidden switch to enter level 2 programming. Continue to press the right hidden switch until the display reads "Calibrate Flow?".
- Step 3:** Press YES to advance to the "Spray Head Cal?" function screen.
- Step 4:** Press YES. The display will read "Container Ready?" If the container is under the funnel, press YES. The display will read "Calibrate Spray... Press Brew to Start".
- Step 5:** Press and release the BREW switch (on the side to be calibrated for Dual Brewers). The display will read "Calibrate Spray...60 Sec to Finish". The 60 second timer on the display will count down to zero. When the counter reaches zero, the display will change to OZ, along with the existing ounces per minute.
- Step 6:** Measure the amount of water in the container and using the (-) or (+), adjust the amount on the display to match the amount in the container. Then press DONE.
- Step 7:** The display should now read "New Spray Flow" along with the correct flow rate of the sprayhead in ounces per minute. After 5 seconds, the display will return to the "Calibrate Flow?" screen.

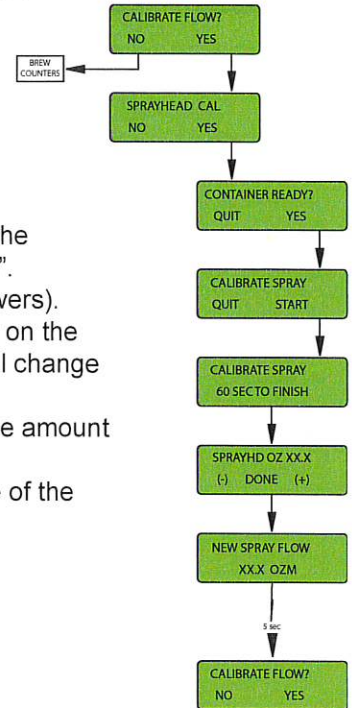

The recipe card includes all the information needed to set up that particular tea/coffee name. The information from the recipe card is loaded into the brewer's memory by holding the chip area up to the brewer's sensing coil. This information can include all the recipe settings for that particular name. These can all be loaded in seconds.

Note: Instructions to program the brewer are printed on the recipe card, along with the tea or coffee name that is being programmed.

Procedure to program the coffee name:

Step 1: Remove the funnel.

Step 2: Position the recipe card vertically, so that the top end of the chip is beneath the sensing coil (located on the under side of the front panel).

Step 3: After a short pause the display will read "Card Contains Recipe For" then will change to "Recipe Name" (SHOW-QUIT-SAVE). All brewing parameters for that recipe are now transferred from the card to the brewer.

Step 4: To show (view) this information, press and release SHOW. The display will scroll through all of the brew settings for that recipe. This display will then return to "Card Contains Recipe For" then will change to "Recipe Name" (SHOW-QUIT-SAVE).

Step 5: If all brew settings are correct, press SAVE. The display will read "Recipe Name Setup Complete". All brew settings for that name are now stored in the Brewer's memory.

Step 6: If the brewing information is not correct, or it is desired to exit the setup before the settings are loaded into the brewer's memory, press QUIT. The display will read "Recipe Name Not Saved". The display will then return to the main screen.

PM Steps

Step 1: Disassemble and clean the strainer assembly:

- Use Channel lock pliers to remove the 1/4" flare to 3/4" hose thread adapter fitting from the water inlet assembly
- Use needle nose pliers to gently pull the strainer straight out.
- Rinse the mesh screen to remove any debris build-up.
- Reassembly is the opposite of disassembly.

Step 2: Remove and clean the temperature sensor:

- Gently pull the temperature sensor from the grommet in the top of the tank.
- Wipe any mineral build-up from the probe.
- Reinstallation is the opposite of removal.

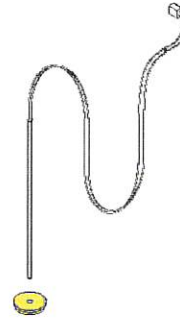

Step 3: Remove and clean the fill probe:

- Gently pull the fill probe out of the grommet .
- Wipe any mineral deposits off of the probe.
- Reinstallation is the opposite of removal.

Step 4: Remove and clean the sprayhead:

- Using the pointed end of the delimiting tool, remove any mineral build-up from the sprayhead outlet holes.

Step 5: Rebuild the dispense solenoid:

- Remove the hose clamps that secure the tubing to the valve.
- Remove the two nuts that hold the solenoid bracket to the machine.
- Gently remove the tubing from the valve body.
- Using a flat blade screwdriver, remove the four screws and separate the valve assembly.
- Replace plunger, spring, and rubber seat using the rebuild kit BUNN P/N:11517.0008.
- Clean any mineral build-up from the valve.
- High-limit thermostats.
- Reassembly is the opposite of disassembly.

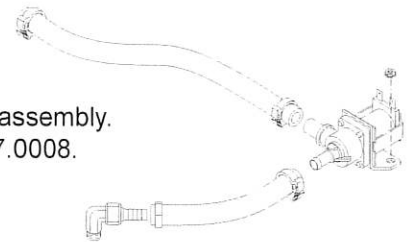

Step 6: Replace the seat cup in the hot water faucet (annually):

- Unscrew the faucet bonnet from the assembly.
- Remove the old faucet seat cup.
- Install the new seat cup BUNN P/N: 02766.0000.
- Reassembly is the opposite of disassembly.
- Visually examine the power cord for any damage.
- Visually examine the water supply for any leaks.



Step 7: Clean the funnel:

- Unscrew the outlet tip and remove the tip and screen.
- Sanitize the tip, screen, and funnel with warm water and sanitize solution.

Step 8: Replace the tea server seat cups:

- Drain the server.
- Unscrew the faucet handle.
- Remove and replace the seat cup.



Step 9: Calibrate the sprayhead and dilution flow rates.

BUNN®

ICB/ITCB GRAPHIC OVERLAY KIT INSTRUCTIONS

GENERAL: The following instructions are for GRAPHIC OVERLAY KITS #39173.0000 & #39173.0001. Determine which graphic layer below is to be installed before proceeding.

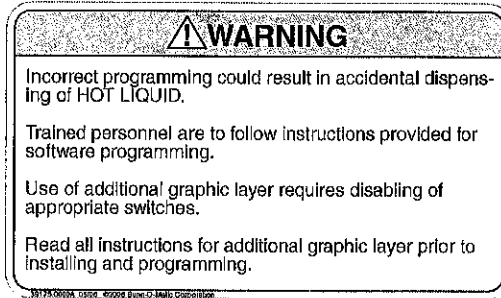

NOTICE: Read all instructions prior to installing and programming. When servicing or programming, remove the additional graphic layer to access all switches.

Graphic Layer to be used:

Required Action:

#1



No additional programming changes required

#2



Follow instructions to disable "Brew B" Button and set "Full" and "Half" Buttons to same recipe settings.

#3



Follow instructions to disable "Brew A" and "Brew C" Buttons.

BUNN-O-MATIC CORPORATION
POST OFFICE BOX 3227
SPRINGFIELD, ILLINOIS 62708-3227
PHONE: (217) 529-6601 FAX: (217) 529-6644

Procedure to deactivate Brew Button(s) (for graphic layers 2 & 3):

Notice: Read all instructions prior to installing and programming. Make programming changes before applying additional graphics layer. Make programming changes with factory graphics so all switches are visible and labeled.

1. Press and hold the right hidden button until the display reads **SET LANGUAGE**. Press the right hidden button until the display reads **ASSIGN RECIPE?** Press **YES**.
2. The display should now read **SELECT RECIPE BREW SWITCH A**, and then will display the recipe currently assigned to the Brew A button.
 - a. To disable Brew A (for graphic layer #3), use (+) to scroll to the end of the recipes until the display reads **DISABLED**. Press and release **DONE** to disable brew button A.
 - b. To keep Brew A enabled (for graphic layer #1 or #2), use (-) and (+) to scroll through available recipes until the desired recipe is displayed. Press and release **DONE** to set that recipe for brew button A.
3. The display should now read **SELECT RECIPE BREW SWITCH B**, and then will display the recipe currently assigned to the Brew B button.
 - a. To disable Brew B (for graphic layer #2), use (+) to scroll to the end of the recipes until the display reads **DISABLED**. Press and release **DONE** to disable brew button B.
 - b. To keep Brew B enabled (for graphic layer #1 or #3), use (-) and (+) to scroll through available recipes until the desired recipe is displayed. Press and release **DONE** to set that recipe for brew button B.
4. The display should now read **SELECT RECIPE BREW SWITCH C**, and then will display the recipe currently assigned to the Brew C button.
 - a. To disable Brew C (for graphic layer #3), use (+) to scroll to the end of the recipes until the display reads **DISABLED**. Press and release **DONE** to disable brew button C.
 - b. To keep Brew C enabled (for graphic layer #1 or #2), use (-) and (+) to scroll through available recipes until the desired recipe is displayed. Press and release **DONE** to set that recipe for brew button C.
5. The display should now read **REVIEW RECIPES**. To exit to the **MAIN SCREEN**, press and release the **ON/OFF** button.

Procedure to disable multiple batch size option (for graphic layer #2):

Notice: Read all instructions prior to installing and programming. Make programming changes before applying additional graphics layer. Make programming changes with factory graphics so all switches are visible and labeled.

NOTE: If using a graphic layer with no batch buttons, the recipe settings for **HALF** and **FULL** batch must be identically set to ensure the desired recipe is used.

NOTE: Each recipe assigned to a brew switch must be modified. Verify what recipes are assigned to the brew switches before modifying recipes.

1. If Brew A is NOT disabled: With the ON/OFF switch off (LED is not lit), press the Brew A button to verify the assigned recipe for Brew A. If Brew A is disabled, proceed to step 2.
2. If Brew B is NOT disabled: With the ON/OFF switch off (LED is not lit), press the Brew B button to verify the assigned recipe for Brew B. If Brew A is disabled, proceed to step 3.

3. If Brew C is NOT disabled: With the ON/OFF switch off (LED is not lit), press the Brew C button to verify the assigned recipe for Brew C.
4. Refer to Installation & Operating Manual to modify recipe settings for each of the recipes identified above.

IMPORTANT!! Half and Full batch settings must be identical!

5. For ICB, modify/verify settings for:
 - a) Brew Oz.
 - b) % Bypass
 - c) Pulse Brew
 - d) Drip Time
6. For ITCB, modify/verify settings for:
 - a) Brew Oz.
 - b) Dilute Oz.
 - c) Dilute Delay
 - d) Pulse Brew
 - e) Drip Time
7. For graphic layers #1 and 2, repeat steps #5 or 6 for each recipe that is assigned to a brew button.

Procedure to install additional graphic layer:

CAUTION!

Read all instructions prior to installing and programming. Brewer must be unplugged before applying the additional layer. Failure to unplug brewer may result in unintentional activation of brewer, or unwanted changes to programming settings.

Once all programming is set correctly as stated above, follow these steps to install the additional graphics layer on the brewer:

1. Unplug brewer from power source.
2. Remove protective backing from the graphic layer.
3. Using the outside edge and LCD window, line up new graphic layer and place over existing layer. The existing/old layer should not be visible.
4. Firmly press around outer edges, corners and around the LCD window to ensure the adhesive is properly engaged.
5. Apply flavor labels to new graphics layer.
6. Plug brewer back into correct power source.

BUNN®

ITCB Flip Tray Instructions

PART NUMBERS

29504.0003	6	Shoulder Screw
00970.0000	6	8-32 Nut
38578.0000	1	Anti-skid Decal
38704.0000	1	Tray Assy (contains tray and decal)

INSTRUCTIONS

1. For use with thermal carafes and smaller decanters; place the tray in the upper position as shown in Figure 1.
2. For use with airpots; place the tray in the lower position, as shown in Figure 2.
3. For use with large dispensers, or for brewing tea; place the tray in the storage position as shown in Figure 3.



FIGURE 1



FIGURE 2

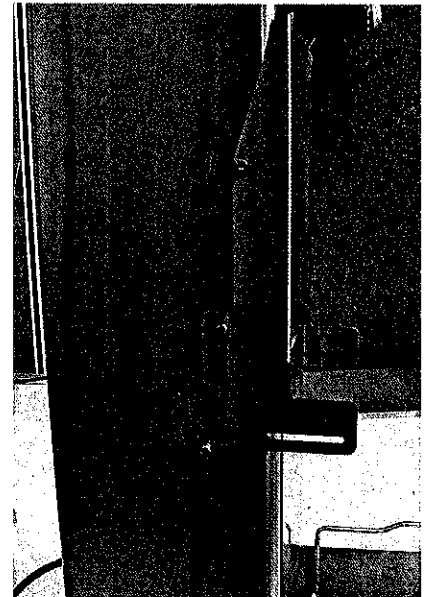

FIGURE 3

BUNN-O-MATIC CORPORATION

POST OFFICE BOX 3227

SPRINGFIELD, ILLINOIS 62708-3227

PHONE: (217) 529-6601 FAX: (217) 529-6644

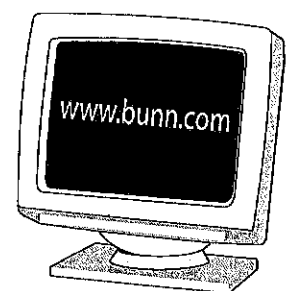

BUNN®

ITCB FAUCET Installation

INTRODUCTION

This instruction details installation of the hot water faucet on the front control panel.

CONTENTS

ITEM	PART NO.	QTY.	DESCRIPTION
1	12422.0009	2	Clamps
2	32591.0031	1	Tubing .5" x 14.0"
3	41193.0001	1	Tubing .375" x 1.2"
4	29075.0000	1	Faucet
5	01544.0000	1	Washer
6	29264.0000	1	Nut

INSTRUCTIONS

1. With tank empty and unit unplugged – remove top cover and front panel.
2. Remove the cap and clamp from tank fitting.

If faucet is to be installed on the front of the hood:

NOTE: *It is recommended to remove the control board prior to installing the faucet to the front of the hood.*

3. Remove the black plug on the front of the bezel.
4. Install .5" ID tubing approx. 14.0" long over tank fitting and secure with 12422.009 clamp (fully tighten).
5. Insert faucet shank through the bezel and secure to hood with 01544.0000 washer and 29264.0000 nut. Make sure faucet is straight when tightening.
6. Install the short (1.2") .375" ID tubing 41193.0001 over end of faucet shank.
7. Slide loose end of the 1/2" tubing from the tank over the .375" tubing on the faucet shank. Secure with 12422.0009 clamp (fully tighten).
8. Turn on the water.
9. Plug in the brewer and allow it to fill.
10. Check the new connections for leaks.
11. Reinstall top cover and front panel.

BUNN-O-MATIC CORPORATION

POST OFFICE BOX 3227

SPRINGFIELD, ILLINOIS 62708-3227

PHONE: (217) 529-6601 FAX: (217) 529-6644

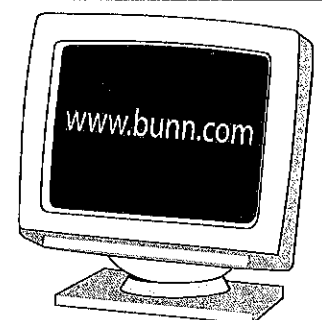

BUNN®

***ITCB
ITCB-DV
Infusion Series®***

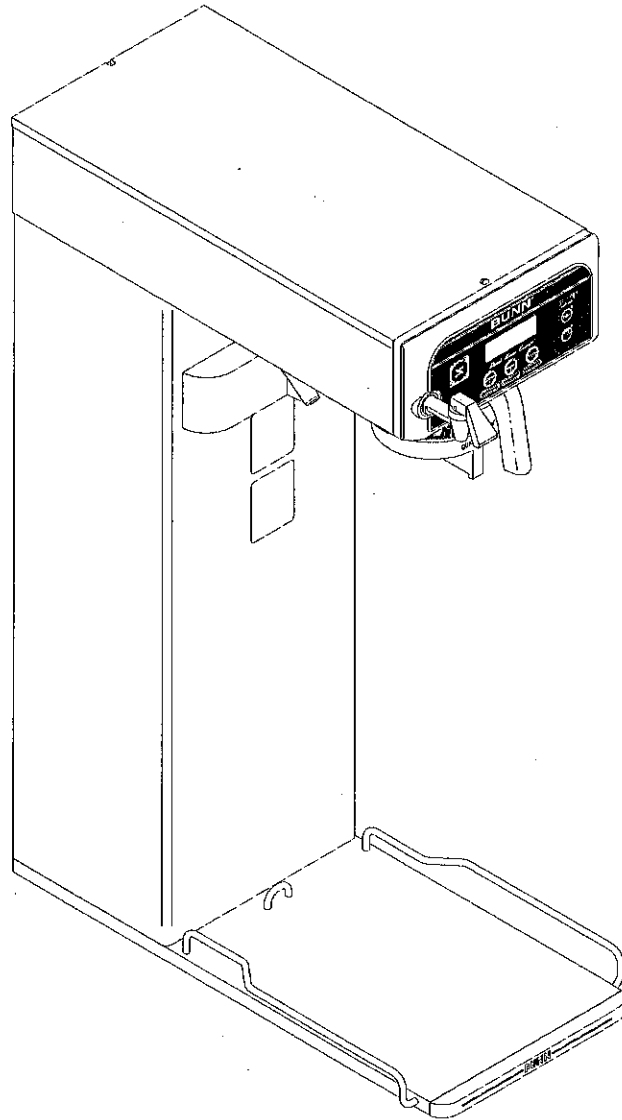

OPERATING & SERVICE MANUAL

BUNN-O-MATIC CORPORATION

POST OFFICE BOX 3227

SPRINGFIELD, ILLINOIS 62708-3227

PHONE: (217) 529-6601 FAX: (217) 529-6644

BUNN-O-MATIC COMMERCIAL PRODUCT WARRANTY

Bunn-O-Matic Corp. ("BUNN") warrants equipment manufactured by it as follows:

- 1) All equipment other than as specified below: 2 years parts and 1 year labor.
- 2) Electronic circuit and/or control boards: parts and labor for 3 years.
- 3) Compressors on refrigeration equipment: 5 years parts and 1 year labor.
- 4) Grinding burrs on coffee grinding equipment to grind coffee to meet original factory screen sieve analysis: parts and labor for 3 years or 30,000 pounds of coffee, whichever comes first.

These warranty periods run from the date of installation BUNN warrants that the equipment manufactured by it will be commercially free of defects in material and workmanship existing at the time of manufacture and appearing within the applicable warranty period. This warranty does not apply to any equipment, component or part that was not manufactured by BUNN or that, in BUNN's judgment, has been affected by misuse, neglect, alteration, improper installation or operation, improper maintenance or repair, damage or casualty. This warranty is conditioned on the Buyer 1) giving BUNN prompt notice of any claim to be made under this warranty by telephone at (217) 529-6601 or by writing to Post Office Box 3227, Springfield, Illinois 62708-3227; 2) if requested by BUNN, shipping the defective equipment prepaid to an authorized BUNN service location; and 3) receiving prior authorization from BUNN that the defective equipment is under warranty.

THE FOREGOING WARRANTY IS EXCLUSIVE AND IS IN LIEU OF ANY OTHER WARRANTY, WRITTEN OR ORAL, EXPRESS OR IMPLIED, INCLUDING, BUT NOT LIMITED TO, ANY IMPLIED WARRANTY OF EITHER MERCHANTABILITY OR FITNESS FOR A PARTICULAR PURPOSE. The agents, dealers or employees of BUNN are not authorized to make modifications to this warranty or to make additional warranties that are binding on BUNN. Accordingly, statements by such individuals, whether oral or written, do not constitute warranties and should not be relied upon.

If BUNN determines in its sole discretion that the equipment does not conform to the warranty, BUNN, at its exclusive option while the equipment is under warranty, shall either 1) provide at no charge replacement parts and/or labor (during the applicable parts and labor warranty periods specified above) to repair the defective components, provided that this repair is done by a BUNN Authorized Service Representative; or 2) shall replace the equipment or refund the purchase price for the equipment.

THE BUYER'S REMEDY AGAINST BUNN FOR THE BREACH OF ANY OBLIGATION ARISING OUT OF THE SALE OF THIS EQUIPMENT, WHETHER DERIVED FROM WARRANTY OR OTHERWISE, SHALL BE LIMITED, AT BUNN'S SOLE OPTION AS SPECIFIED HEREIN, TO REPAIR, REPLACEMENT OR REFUND.

In no event shall BUNN be liable for any other damage or loss, including, but not limited to, lost profits, lost sales, loss of use of equipment, claims of Buyer's customers, cost of capital, cost of down time, cost of substitute equipment, facilities or services, or any other special, incidental or consequential damages.

BUNN, Infusion Series, BrewWISE, CDBC, DBC, ITCB, MHG, Pre-Infusion, Pulse Brew, Smart Funnel, Energy Savings, BUNNLink, Smart Reader, Freshness Timer and Sanitation Alert are either trademarks or registered trademarks of Bunn-O-Matic Corporation.

INTRODUCTION

This equipment will brew either tea or coffee into an awaiting dispenser or reservoir. It can be easily configured for 120V 15 amp, 120/208V 20 amp or 120/240V 20 amp. The brewer may have an auxillary hot water faucet. It is only for indoor use on a sturdy counter or shelf.

The Infusion Series combines BrewWISE, CDBC and Tea Brewers into one. ITCB is able to brew both tea and coffee with recipe settings and has the following features: Pre-Infusion and Pulse Brew, quick and standard brew, and BrewWISE. It has an LCD for digital readout and programming along with the Smart Funnel options for coffee. The user is able to select regular or quick brew for tea programming. Other features are Energy Savings mode, BUNNLink compatible, Smart Reader compatible, Freshness Timer and Sanitation Alert.

CONTENTS

Warranty	2
Introduction	3
User Notices	4
Electrical Requirements	6
Plumbing Requirements	7
Tank Drain	7
Operating Controls	8
Initial Set-Up	9
Tea Brewing	9
Coffee Brewing	10
Cleaning	11
Glossary	12
Programming	14
Troubleshooting	63
Wiring Diagrams	77

ITCB-DV	Dual Voltage Machine
ITCB-C-DV	Dual Voltage Machine for Canada
ITCBA	230 Volt Machine
ITCBB	200 Volt Machine

USER NOTICES

Carefully read and follow all notices in this manual and on the equipment. All labels on the equipment should be kept in good condition. Replace any unreadable or damaged labels.

This equipment is to be installed to comply with the Basic Plumbing Code of the Building Officials and Code Administrators International, Inc. (BOCA) and the Food Service Sanitation Manual of the Food and Drug Administration (FDA).

#00656.0000

⚠ WARNING

DO NOT OVERLOAD CIRCUIT. ALWAYS ELECTRICALLY GROUND THE CHASSIS OR ADAPTOR PLUG. DO NOT DEFORM PLUG OR CORD. FOLLOW NATIONAL AND LOCAL ELECTRICAL CODES. KEEP COMBUSTIBLES AWAY.

FAILURE TO COMPLY RISKS EQUIPMENT DAMAGE, FIRE OR SHOCK HAZARD.

READ THE ENTIRE OPERATING MANUAL BEFORE USING THIS PRODUCT

00986.0000E 5/98 ©1994 Bunn-O-Matic Corporation

#00986.0000

⚠ WARNING

 **FUNNEL CONTENTS ARE HOT**

DISCARD DECANTER IF:

- CRACKED
- SCRATCHED
- BOILED DRY
- HEATED WHEN EMPTY USED ON HIGH FLAME OR EXPOSED ELECTRIC ELEMENTS

READ THE ENTIRE OPERATING MANUAL BEFORE USING THIS PRODUCT FAILURE TO COMPLY RISKS INJURY

PN: 00656.0000F 6/98 © 1985 BUNN-O-MATIC CORPORATION

#00658.0000

⚠ WARNING

To reduce the risk of electric shock, do not remove or open cover. No user-serviceable parts inside. Authorized service personnel only. Disconnect power before servicing.

37881.0000

USER NOTICES (CONT.)

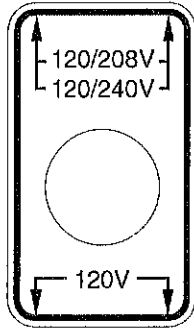

#34056.0001



#03408.0000

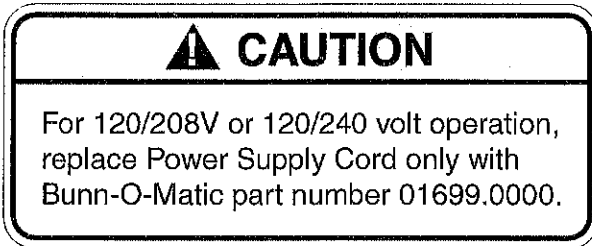

#34072.0000

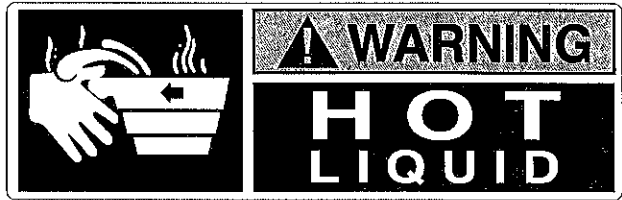

#03409.0000

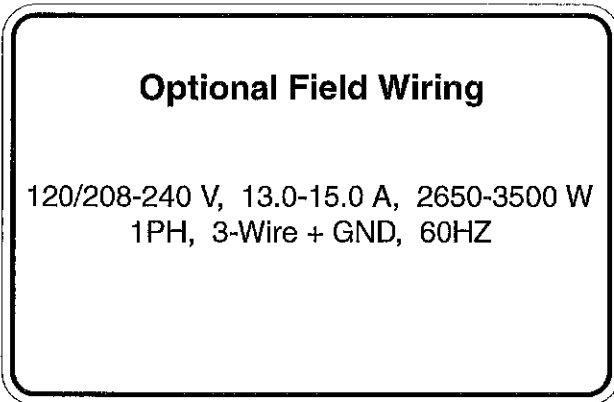

#29710.0009

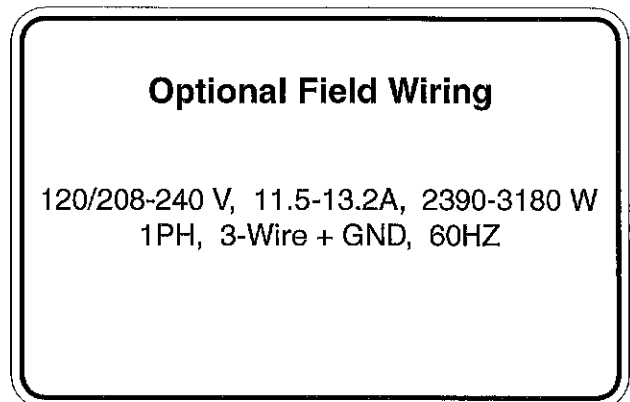

#29710.0010

ELECTRICAL REQUIREMENTS

WARNING - The brewer must be disconnected from the power source until specified in *Initial Set-Up*.

Requirements for brewers without an attached cord set are as follows:

Refer to Data Plate on the Brewer, and local/national electrical codes to determine circuit requirements.

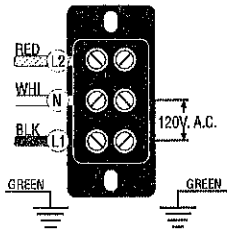

**120V AC
single phase models**

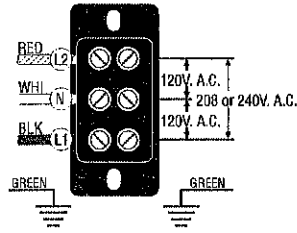

**120/208 & 120/240V AC
single phase models**

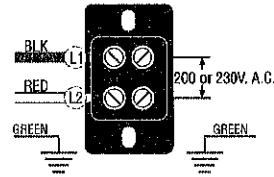

**200 or 230V AC
single phase models**

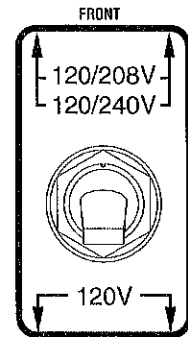
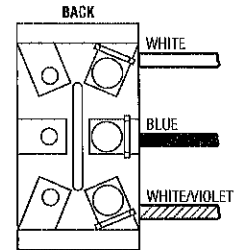

**DUAL VOLT
TOGGLE SWITCH**

Note: The two electrical services above require 3 current carrying conductors (Neutral, L1 and L2) and a separate conductor for earth ground

Note: This electrical service consists of 2 current carrying conductors (L1 and L2) and a separate conductor for earth ground.

ELECTRICAL HOOK-UP

CAUTION – Improper electrical installation will damage electronic components.

1. An electrician must provide electrical service.
2. Determine the available on-site electrical service.
3. Select the desired unit voltage based on the available on-site electrical service.
4. Using a voltmeter, check the voltage and color coding of each conductor at the electrical source.
5. Remove the back access panel to gain access to the terminal block.
6. Feed the supply leads through the strain relief at the rear of the brewer.
7. Using the above diagrams, connect the desired electrical service to the field wiring terminal block.
8. If wiring the machine for operation on 120/208 or 120/240 volts with a Power Supply Cord, the Power Supply Cord must be UL Listed Flexible Cord Type SO, SJO, SJTO, HSJO or SJOW, No. 12 AWG, 4 Conductor, Rated 90° C. Attachment Plug Cap must be UL Listed, NEMA 14-20P or L14-20P Configuration, Rated 125/250V, 20 AMPS. If wiring the brewer for operation at 200V or 230V with a Power Supply Cord, the Power Supply Cord must be of type "H07RN-F" with <HAR> marking, 1.5 mm² conductor size, rated minimum 90°C. Attachment male plug must be appropriate for Local/National use and must meet any Local/National Regulatory requirements/certifications if applicable. The Power Supply Cord must be at least 3 feet (.91 m) long and maximum 6 feet (1.82 m) long (measured from Strain Relief to end of the Attachment Plug Cap).
- NOTE:** If the power cord is damaged, it must be replaced by the manufacturer or its service agent or a similarly qualified person in order to avoid a hazard.
9. Connect the brewer to the power source and verify th
9. Connect the brewer to the power source and verify the voltage at the terminal block.
10. Set toggle switch on component bracket to the appropriate position and replace the access panel.
11. If plumbing is to be hooked up later be sure the brewer is disconnected from the power source. If plumbing has been hooked up, the brewer is ready for *Initial Set-Up*.

PLUMBING REQUIREMENTS

This brewer must be connected to a cold water system with operating pressure between 20 and 90 psi (138 and 620 kPa) from a ½" (12.7 mm) or larger supply line. A shut-off valve should be installed in the line before the brewer. Install a regulator in the line when pressure is greater than 90 psi (620 kPa) to reduce it to 50 psi (345 kPa). The water inlet fitting is ¼" (6.35 mm) flare.

NOTE - Bunn-O-Matic recommends ¼" (6.35 mm) copper tubing for installations of less than 25 feet (7.62 m) and ⅜" (9.5 mm) for more than 25 feet (7.62 m) from the ½" (12.7) water supply line. A tight coil of copper tubing in the water line will facilitate moving the brewer to clean the counter top. Bunn-O-Matic does not recommend the use of a saddle valve to install the brewer. The size and shape of the hole made in the supply line by this type of device may restrict water flow.

This equipment must be installed to comply with the Basic Plumbing Code of the Building Officials and Code Administrators International, Inc. (BOCA) and the Food Service Sanitation Manual of the Food and Drug Administration (FDA). For models installed outside the U.S.A., you must comply with the applicable Plumbing/Sanitation Code for your area.

PLUMBING HOOK UP

1. Flush the water line and securely attach it to the inlet fitting at the bottom rear of the brewer.
2. Turn on the water supply.

TANK DRAIN

1. Remove back access cover.
2. Close the white clamp on the drain hose.
3. Unfasten the hose clamp at the inlet valve. Remove the hose from the valve.
4. Place the end of the drain hose in a container that has a minimum capacity of 2.0 gallons (7.5 liters).
5. Release the white clamp to drain the water from the tank.
6. When tank is empty, leave the white clamp open, and install the hose back on the valve. Tighten the hose clamp at the end of the hose around the valve fitting.
7. Replace the back access cover.

OPERATING CONTROLS

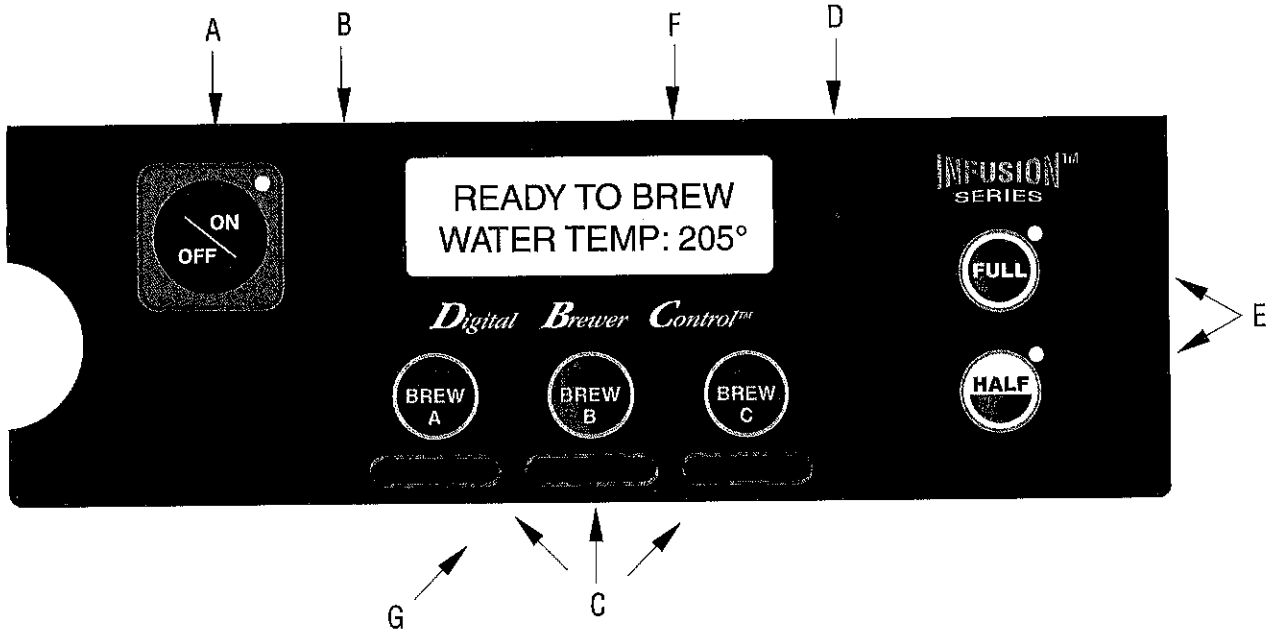

A. ON/OFF SWITCH

Pressing the "ON/OFF" pad will alternately turn the brewer on and off. Pressing this pad during the brew cycle will interrupt the brew cycle, stopping the flow of water. Pressing this pad during programming of the brewer will exit the setup and return to the main screen.

B. PROGRAMMING (left)

This hidden pad can be used to scroll backwards through the function list while in programming mode.

C. BREW (A,B,C) and FUNCTION

When the ON/OFF is ON and the brewer is on the main screen (not in programming mode), momentarily pressing and releasing this pad will begin a brew cycle. These are also used to program the brewer when in the programming mode.

D. PROGRAMMING (right)

Pressing and holding this pad allows entry into the programming menus. Pressing and releasing the pad steps through each function screen while in the programming mode.

E. BATCH SELECTOR PADS

Pressing the pad corresponding to the Half or Full batch selects the amount of product to be brewed. Pressing a different pad after a brew cycle has been initiated does not change the brew batch in progress. Light indicates the selected batch to brew. Also used in programming to adjust settings on both batch sizes.

F. FUNCTION SCREEN

This is the display which shows the various functions of the brewer and allows the programming to be accomplished.

G. FUNNEL SENSING COIL

This is used to "receive" information from the Smart Funnel handle, recipe cards, and ad cards.

INITIAL SET-UP

1. Insert an empty funnel into the funnel rails.
2. Place an empty server under the funnel.
3. Connect the brewer to the power source. Make sure the ON/OFF switch is ON (LED will be lit).
4. Water will flow into the tank and stop when the tank is filled to its capacity. Display will show **PLEASE WAIT... TANK FILLING** until tank is filled with water.
5. Wait approximately twenty minutes for the water in the tank to heat to the proper temperature. Display will show **READY TO BREW... WATER TEMP: 205°** when tank is at operating temperature. Some water will drip from the funnel during this time; this is due to expansion and should not occur thereafter.
6. Place a small vessel beneath the faucet and open the faucet handle. Release it when you hear the tank refilling.
7. Water volumes and flow settings have been preset at the factory. Refer to adjustments for the Set Brew Volumes section of this manual should the volume need to be increased or decreased.
8. The brewer is now ready for use in accordance with the instructions for Tea Brewing and Coffee Brewing.

Brew water temperature is factory set at 200° F (93.3° C)
Areas of high altitude will require lowering this temperature to prevent boiling. This chart should be used as a guide when readjusting the brew water temperature.

Altitude (Feet)	Boiling point of water		Recommended water temperature	
	° F	° C	° F	° C
-1000	213.8	101.0	200	93.3
-500	212.9	100.5	200	93.3
0	212.0	100.0	200	93.3
500	211.1	99.5	200	93.3
1000	210.2	99.0	200	93.3
1500	209.3	98.5	200	93.3
2000	208.4	98.0	200	93.3
2500	207.4	97.4	200	93.3
3000	206.5	96.9	199	92.8
3500	205.6	96.4	198	92.2
4000	204.7	95.9	197	91.7
4500	203.8	95.4	196	91.1
5000	202.9	94.9	195	90.6
5500	201.9	94.4	195	90.6
6000	201.0	93.9	194	90.0
6500	200.1	93.4	193	89.4
7000	199.2	92.9	192	88.9
7500	198.3	92.4	191	88.3
8000	197.4	91.9	190	87.8
8500	196.5	91.4	189	87.2
9000	195.5	90.8	188	86.7
9500	194.6	90.3	187	86.1
10000	193.7	89.8	186	85.6

VIEWING ASSIGNED RECIPES & ASSET NUMBER

1. Make sure the ON/OFF switch is OFF (LED will not be lit).
2. Press and hold BREW A. The display will show the name of the recipe assigned to Brew A along with SWITCH NOT ON. This is to indicate that a brew cannot be initiated while the ON/OFF switch is OFF.
3. Repeat for BREW B and BREW C.
4. Make sure the ON/OFF switch is OFF. To view the asset number of the machine, press and hold the left hidden button until the display reads: **ANXXXXXX...ASSET NUMBER**. Release the left hidden button.
5. After a 5 second delay, the display will read: **ITCBXXXXXX**. This is the serial number of the machine.

TEA BREWING

1. Begin each brew cycle with a clean empty brew funnel and server. (Be sure the server lid doesn't interfere with the flow of dilution water.)
2. Insert a BUNN filter into the funnel.
3. Pour the packet of loose fresh tea leaves into the filter. Approximately three to five ounces is recommended for three gallons of beverage.
4. Level the bed of tea leaves by gently shaking.
5. Slide the funnel into the funnel rails until it stops.
6. The ON/OFF must be ON. Select which batch size to brew.
7. Momentarily press and release the assigned BREW button. There may be certain situations in which the brew cycle will not begin when BREW is pressed:
 - a. **SWITCH NOT ON** - ON/OFF must be ON.
 - b. **BREW TEMPERATURE TOO LOW** – wait until heated or cancel **BREW LOCKOUT** option (Page 17).
 - c. **CHECK FUNNEL** – remove funnel, empty previously brewed leaves and replace with fresh tea leaves.
 - d. **DISABLED** - select different brew button or batch size.
8. If none of the above messages are displayed, the display will read **NOW BREWING** and show the time remaining in the brew cycle.
9. Following the brew will be a countdown of drip time **DRIPPING** which shows the time remaining until the tea no longer drips from the funnel tip.
10. Carefully remove the brew funnel and discard the tea leaves and filter only after visible dripping stops.

COFFEE BREWING

WITHOUT A SMART FUNNEL AND G9-2T DBC GRINDER:

1. Begin each brew cycle with a clean empty brew funnel.
2. Insert a BUNN filter into the funnel.
3. Pour the fresh coffee into the filter and level the bed of grounds by gently shaking.
4. Slide the funnel into the funnel rails until it stops.
5. Place an empty server under the funnel.
6. The ON/OFF must be ON. Select the FULL batch size.
7. Momentarily press and release the assigned BREW button. There may be certain situations in which the brew cycle will not begin when BREW is pressed:
 - a. **SWITCH NOT ON** - ON/OFF must be ON.
 - b. **BREW TEMPERATURE TOO LOW** – wait until heated or cancel **BREW LOCKOUT** option (Page 17).
 - c. **CHECK FUNNEL** – remove funnel, empty previously brewed grounds and replace with fresh.
 - d. **DISABLED** - select different brew button or batch size.
 - e. **COFFEE FUNNEL?** – appears when brew volume is greater than 86.0 oz. (2.54 L) and pulse brew is disabled. Check to make sure the correct funnel is in place, and then press BREW again.
8. If none of the above messages are displayed, the display will read **NOW BREWING** and show the time remaining in the brew cycle.
9. Following the brew will be a countdown of drip time **DRIPPING** which shows the time remaining until the coffee no longer drips from the funnel tip.
10. Carefully remove the brew funnel and discard the grounds and filter only after visible dripping stops.

WITH A SMART FUNNEL AND G9-2T DBC or MHG GRINDER:

1. Select the small batch size on the grinder.
2. Insert a BUNN filter into the funnel.
3. Grind the selected amount of fresh coffee into the Smart Funnel using the G9-2T DBC or MHG with Smart Funnel operation and level the grounds by gently shaking.
4. Slide the funnel into the funnel rails. The brewer will read the coffee name and size ground through the chip in the funnel handle.

NOTE: The brewer will automatically match the brew batch size to the grinder batch size:

<u>GRINDER</u>	<u>BREWER</u>
Small	Half Batch
Medium	Full Batch
Large	*Full Batch

*If BREW is pressed with a large grinder batch, the display will read: **INCORRECT GRIND...BATCH SIZE WRONG**, and then **PRESS BREW TO BREW ANYWAY**.

5. Place an empty server under the funnel.
6. The ON/OFF must be ON.
7. Momentarily press and release the assigned BREW button. There may be certain situations in which the brew cycle will not begin when BREW is pressed:
 - a. **SWITCH NOT ON** - ON/OFF must be ON.
 - b. **BREW TEMPERATURE TOO LOW** – wait until heated or cancel **BREW LOCKOUT** option (Page 17).
 - c. **CHECK FUNNEL** – remove funnel, empty previously brewed grounds and replace with fresh.
 - d. **INCORRECT GRIND** - Indicates a large batch was ground using the grinder. Check batch size and grind weight.
8. If none of the above messages are displayed, the display will read **NOW BREWING** and show the time remaining in the brew cycle.
9. Following the brew will be a countdown of drip time **DRIPPING** which shows the time remaining until the coffee no longer drips from the funnel tip.
10. Carefully remove the brew funnel and discard the grounds and filter only after visible dripping stops.

CLEANING

CAUTION – CLEAN AND SANITIZE YOUR ICED TEA BREWER **DAILY**

1. Remove and thoroughly clean the entire brew funnel. The funnel tip and screen must be free from any tea particles or residue. Reassemble the funnel.
2. Remove and thoroughly rinse the sprayhead. The holes must be open and clear of any mineral deposits. Wipe the sprayhead panel clean with a damp cloth.

NOTE – Any buildup on the sprayhead may restrict water flow, and impact your brewing. For consistently great tea and coffee, clean sprayhead weekly with sprayhead cleaning tool (#38227.0000). Upon visual inspection it may appear that light passes through all holes in the sprayhead, but a thin film of residue can pass light and still impede water flow.

- a. Remove sprayhead from brewer.
 - b. Use the pointed end of sprayhead cleaning tool to remove any mineral deposits from the sprayhead holes.
 - c. Insert the long end of sprayhead cleaning tool into the sprayhead fitting, and rotate several times to remove any mineral deposits from the fitting.
3. The use of a damp cloth rinsed in any mild, nonabrasive, liquid detergent is recommended for cleaning all surfaces on Bunn-O-Matic equipment. Do **NOT** clean this equipment with a water jet device.

CAUTION – DO NOT KEEP BREWED ICED TEA OVERNIGHT. THE SERVER MUST BE CLEANED DAILY.

See page 50 of instruction manual for calibration routine to verify sprayhead flow rate matches programmed flow rate. Brewer may need to be re-calibrated due to lime build up. If brewer is cleaned and build up removed, brewer must be re-calibrated to achieve desired volumes.

GLOSSARY

AD CARD: An assembly consisting of computer chips and an instruction label. Used for loading advertising messages into the brewer.

AUTO PULSE BREW SETUP: The setting of a pulse brew routine by entering in the total desired brew time. The brewer will then calculate and perform a pulse brew routine using a predetermined formula.

BREW LOCKOUT: The inability to initiate a brew if the water temperature is less than the ready temperature programmed into the brewer.

CHIP: A computer chip containing either recipes for specific coffee flavors or advertising messages that are read by the sensing coil on the brewer. One chip is embedded in each Smart Funnel handle to carry the coffee flavor name and batch size ground from the grinder to the brewer.

DILUTION: Water added to tea concentrate.

DILUTION DELAY: The length of time from when the brew is initiated until the dilution water starts.

DRIP TIME: The length of time from when the water spray over the grounds ends to the time when no water or product drips from the funnel tip.

ENERGY SAVINGS MODE: If enabled, the brewer will either shut down or reduce the tank holding temperature to 140°F (60°C) after the set idle time.

FACTORY DEFAULTS: The factory preset brew settings that were installed into the brewer's memory.

FIRST ON-TIME: During a pulse brew, this is the time set for the initial flow of water over the grounds or tea leaves.

FRESHNESS TIMER: If enabled, the brewer will display an alert if a new tea or coffee batch has not been brewed before the set time has expired.

FUNNEL SENSING COIL: A sensor at the front of the brewer that reads what name and batch size of coffee was ground into the funnel and allows for the brewer to automatically set itself to what is read from the funnel handle. Also used to read in recipe and ad card information.

IDLE TIME (ENERGY SAVINGS MODE): If ENERGY SAVINGS Mode is enabled, the length of time the brewer is inactive before the machine turns off or holds at 140°F (60°C).

LAST ON-TIME: During a pulse brew, this is the time set for the second on-time and each alternative on-time for the remainder of the brew.

MAIN SCREEN: The term used to describe the screen that is displayed when the brewer is not in use. This screen is also displayed after exiting the programming mode.

MANUAL PULSE BREW SETUP: The setting of a pulse brew routine by manually entering in the 1st on time, off time and last on time.

MASTER TEMP: The temperature at which the tank will heat to and hold. If the brewer is in Master Temp mode, all initiated brews will be at this temperature.

OFF-TIME: During a pulse brew or preinfusion, this is the time set for the length of time that the water is not spraying over the grounds.

PREINFUSION: The process of beginning a brewing cycle with an initial spray of water onto the grounds followed by a pause in the spray. After the programmed pause, the spray continues without interruption until the end of the brewing cycle.

PULSE BREW: The process that allows the brew water to start, and then stop, repeatedly over the grounds or tea leaves in order to derive the best flavor from the coffee or tea. Pulse brew is also used in some instances to

GLOSSARY (Continued)

prevent a funnel overflow.

RECIPE: Set of brewing parameters stored in the brewer. The parameters are unique for each tea and coffee name. Tea recipes include brew ounces, dilution ounces, dilution delay, pulse brew, and drip time. Coffee recipes include brew ounces, pulse brew and drip time.

RECIPE CARD: An assembly consisting of a computer chip and an instruction label. Used for loading a recipe into the brewer and the companion DBC Grinder.

RECIPE TEMPS: Allows a different temperature to be set for each brew recipe.

NOTE – Using this setting will override the Master Temp setting. The tank will hold at the lowest set temperature. A short heating time may be required if all brew recipes are not set at the same temperature.

SANITATION MODE: If enabled, the brewer will display a message after a set amount of time indicating the machine needs cleaning and sanitizing.

TEA 1, TEA 2, TEA 3, HOT TEA, ICED COFFEE, NO-NAME COFFEE: The preset recipes stored in the brewer. Used by the brewer when there is no coffee name stored in the Smart Funnel or if a recipe card is not used.

WARNING TIME (FRESHNESS TIMER): If the Freshness Timer is enabled, the length of time from when the brew was completed until a “Freshness Alert” message will display, communicating that a fresh batch of product needs to be brewed.

PROGRAMMING

Using the menu-driven display on the front of the brewer, the operator has the ability to alter or modify various brewing parameters such as brew temperatures, brew volumes, dilution volumes, pulse brew, etc. This allows for the precise brewing of various flavors of tea and coffee.

Programming of the brewer is achieved by entering a certain function. Then, by the use of hidden programming switches and the brew/function buttons, the operator can customize the brewing process to their specifications.

PROGRAMMING SWITCHES

To access the programming mode, and to scroll through the different function screens, hidden programming switches are used. There are five of these switches that will be used for the setup of the brewer.

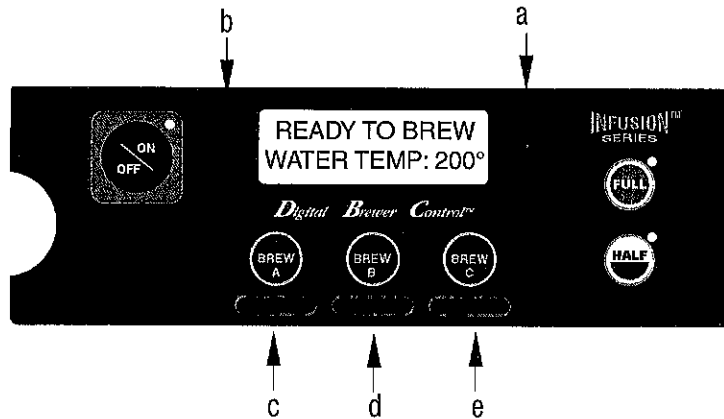

- a) **Right Programming (hidden) button** (just to the right of the display): This is used to access the programming mode, and is also used to scroll forward through the function list.
- b) **Left Programming (hidden) button** (just to the left of the display): This is used to scroll backwards through the function list.
- c) **Brew A**: This is used to select options that appear on the display during programming.
- d) **Brew B**: This is used to select options that appear on the display during programming.
- e) **Brew C**: This is used to select options that appear on the display during programming.

PROGRAMMING SECTION

PROGRAMMING SWITCHES-----	14	REVIEW/MODIFY/SETUP COFFEE RECIPES	
PROGRAMMING THE BREWER -----	15	BREW OZ -----	34
FUNCTION FLOW CHART-----	16	PULSE BREW-----	35
BREW LOCKOUT -----	17	DRIP TIME-----	39
SET LANGUAGE -----	18	SET TEMP -----	40
UNITS-----	19	READY DEGREE -----	41
REVIEW RECIPES -----	20	ENABLE ADS -----	42
ASSIGN RECIPE -----	21	ENABLE SANITATION -----	44
DISABLE BREW SWITCH -----	21	ENABLE ENERGY SAVER-----	45
SET NEW RECIPE (USING A SMART		ENABLE FRESHNESS TIMER -----	46
FUNNEL AND GRINDER)-----	22	REFILL -----	47
SET NEW RECIPE (USING RECIPE CARD) -----	24	FLOW RATES-----	48
SET NEW RECIPE (NO SMART FUNNEL,		CALIBRATE FLOW -----	50
GRINDER OR RECIPE CARD)-----	25	BREW COUNTERS-----	52
REVIEW/MODIFY/SETUP TEA RECIPES		SET RECIPE TEMPS-----	53
BREW OZ -----	26	ASSET NUMBER-----	54
DISABLE BATCH SIZE -----	26	SERVICE NUMBER -----	55
DILUTE OZ -----	27	SERVICE TOOLS-----	56
DILUTE DELAY -----	28	FACTORY DEFAULTS-----	60
PULSE BREW-----	29	DEFAULT SETTINGS-----	61
DRIP TIME -----	33		

PROGRAMMING THE BREWER

The programming of the brewer is divided into two levels. There is one function in Level 1. All other functions are accessed in Level 2.

The following function screens are in order of appearance. Each screen will have instructions on how to access and the procedures to program the various functions of the brewer.

IMPORTANT PROGRAMMING NOTES - READ CAREFULLY -

To exit the programming mode at any time, press and release the ON/OFF pad located on the front switch panel. The display will return to the **MAIN SCREEN**.

If none of the five programming switches are pressed within one minute during the setup of the brewer, the programming of the function screen that is being set will be exited and the display will return to the **MAIN SCREEN**.

Always remember to place a container and funnel under the sprayhead when operating the brewer during the set-up of **CALIBRATE FLOW**, and testing the brew and dilution valves in **SERVICE TOOLS/TEST OUTPUTS**.

MAIN SCREEN

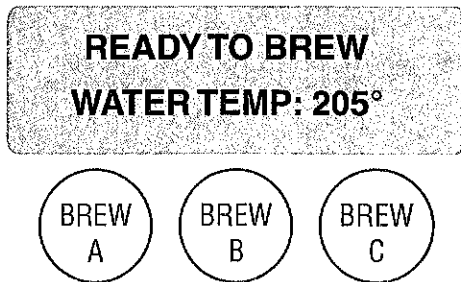

This screen will be shown when the brewer is ready for use. The screen displays the water temperature in the tank. When the water in the tank reaches the correct set temperature, the display will change from **HEATING** to **READY TO BREW**.

PROGRAMMING LOCKOUT SWITCH ((located on the memory module board prior to S/N ICB0007479 - located on the main circuit board S/N ICB0007479 and after))

This switch can be set to prevent access to the programming settings of the brewer. Once all the correct brew settings are programmed, the operator can set the switch to the "ON" position to prohibit anyone from changing the settings. With the switch in the "ON" position, the programming menus can still be accessed to view the current settings. However, no changes will be saved.

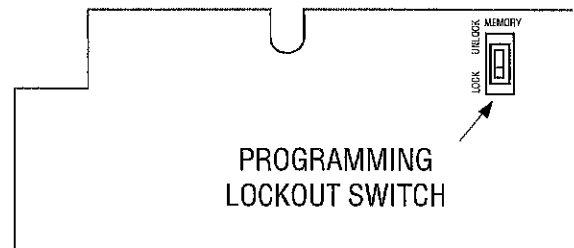

P3048

PROGRAMMING THE BREWER (cont.)

PROGRAMMING FUNCTIONS - FLOW CHART

PROGRAMMING FUNCTIONS - LEVEL 1

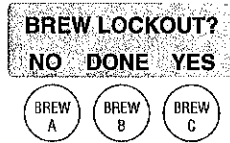

PROGRAMMING FUNCTIONS - LEVEL 2

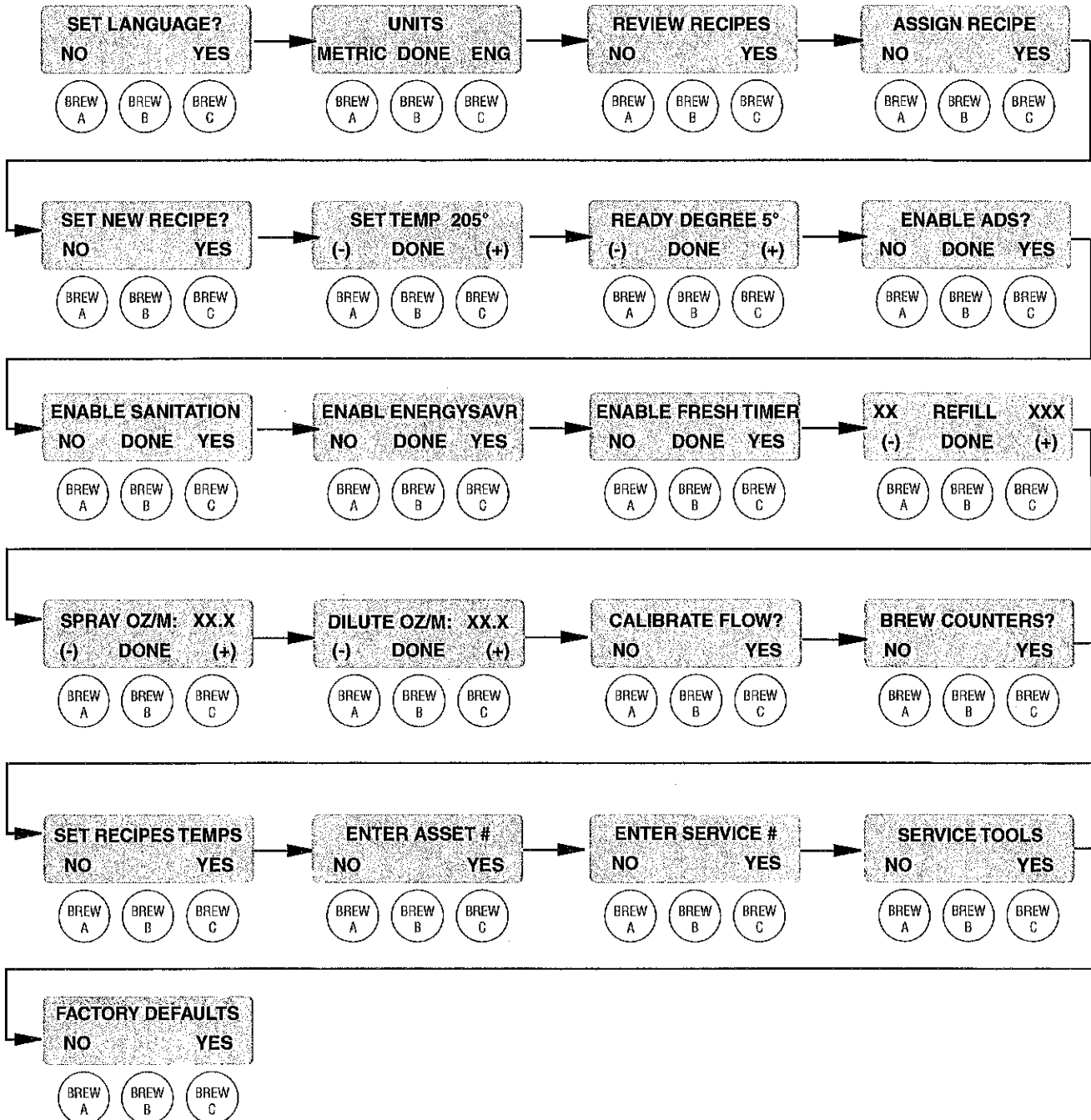

PROGRAMMING THE BREWER (cont.)

PROGRAMMING FUNCTIONS - LEVEL I

BREW LOCKOUT

This function allows the operator to prevent or allow brewing if the water temperature is less than the set **READY** temperature.

Procedure for setting Brew Lockout:

1. To access this function screen press and hold the right hidden button. Release when the display reads:

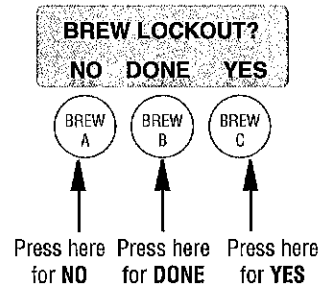

2. The **YES** or **NO** should be flashing. Select **YES** to prevent brewing if the water temperature is below the set **READY** temperature. Select **NO** to permit brewing at any water temperature.
3. When finished, press and release **DONE**. This will exit this function screen and return to the **MAIN SCREEN** on the display.

PROGRAMMING THE BREWER (cont.)

PROGRAMMING FUNCTIONS - LEVEL 2 (cont.)

The functions in the second level of programming allow the operator to adjust brew settings and other feature options.

To access the level 2 function screens press and hold the right hidden button. Release when the display reads:

SET LANGUAGE

This function allows the operator to select the language used for the display.

Procedure for setting Language:

1. Press and hold the right hidden button until the display reads **SET LANGUAGE?** and release.
2. Press **YES** to proceed. The display should now read **ENGLISH**. Using **(-)** and **(+)**, scroll through the available languages until the desired language is shown on the display.
3. When finished, press **DONE**. If the language selected is different from the current settings, the display will read **CHANGE LANGUAGE? ARE YOU SURE?** and then will change to **CHANGE LANGUAGE?** To convert the display to the new language, press **YES**. To retain the current language, press **NO**.
4. The display should now read **UNITS**. To exit programming and return to the **MAIN SCREEN**, press and release the ON/OFF button.

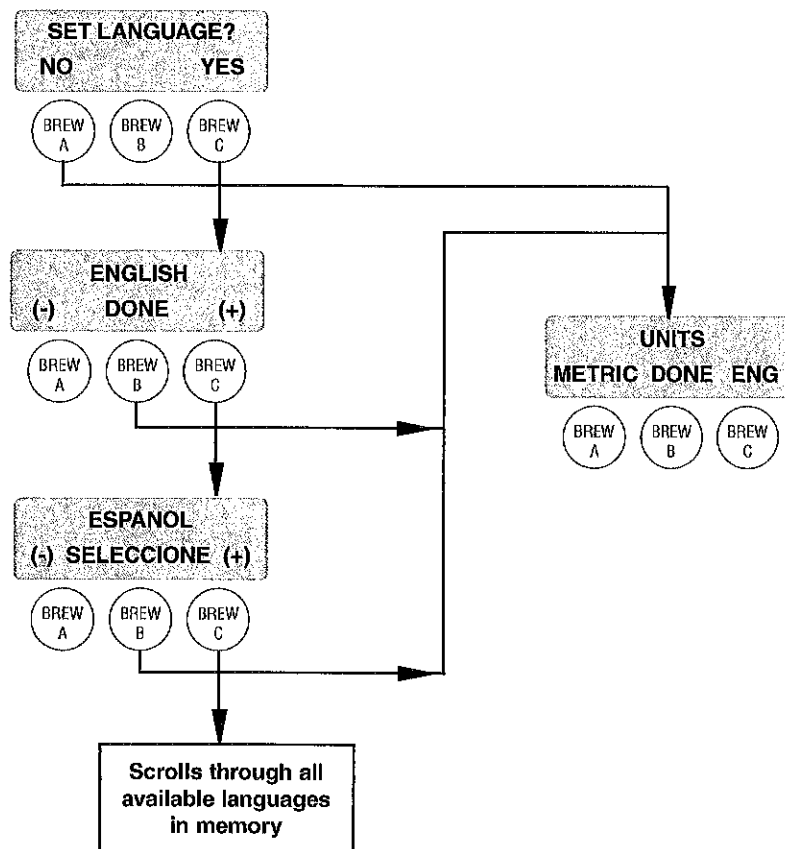

PROGRAMMING THE BREWER (cont.)

PROGRAMMING FUNCTIONS - LEVEL 2 (cont.)

UNITS

This function allows the operator to select if numeric settings are displayed in English or Metric units.

Procedure for setting the Units:

1. Press and hold the right hidden button until the display reads **SET LANGUAGE?** Press and release the right hidden button until the display reads **UNITS**. The **METRIC** or **ENG** should be flashing.
2. Select **METRIC** to have settings displayed in Metric units. Select **ENG** to have setting displayed in English units.

NOTE: Changing the **UNIT** settings will restore ALL settings to Factory Default.

3. When done, press and release **DONE** to retain your settings and advance to the next programming screen. To exit programming and return to the Main Screen, press and release the ON/OFF button.

NOTE: This manual is written based on Factory Default settings (English Units). If the brewer is set for Metric Units, display will be different. (ex: Brew oz will become Brew ml).



PROGRAMMING THE BREWER (cont.)

PROGRAMMING FUNCTIONS - LEVEL 2 (cont.)

REVIEW RECIPES (Modify recipe, set up standard recipes)

This function has three parts:

1. It allows the operator to view the brew settings for the various tea and coffee recipes stored into the brewer.
2. It allows the operator to modify (change) any of the brew settings for a particular recipe stored in the brewer.
3. It is used to set up the standard recipes for Tea, Hot Tea, Iced Coffee and No-Name Coffee.

Procedure for reviewing the recipes:

1. Press and hold the right hidden button until the display reads **SET LANGUAGE**. Press the right hidden button until the display reads **REVIEW RECIPES**. Press **YES**.
2. The display should now read **TEA 1**, along with **MODIFY SHOW** and **NEXT**.
3. Press and release **SHOW**. The screen will scroll through all the brew settings for that particular recipe. When finished, the display will return to the recipe name just viewed.
4. To see the settings again, press **SHOW**. To advance to the next recipe, press **NEXT**.

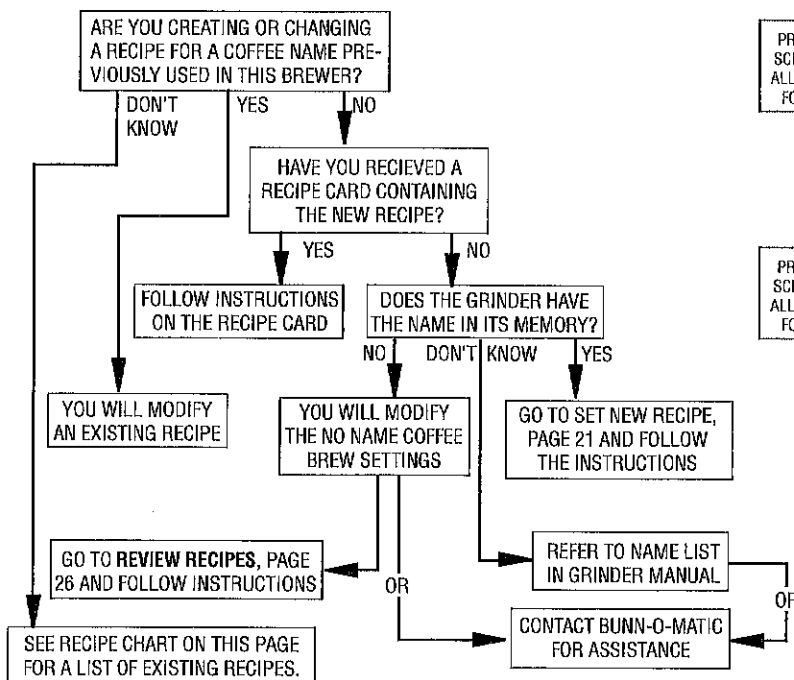

5. To exit, press **NEXT** until the display reads **THAT WAS THE LAST RECIPE**.
6. After 5 seconds, the display will return to the **REVIEW RECIPES** screen. Press and release **NO** to advance to the next function screen, or press and release the ON/OFF pad to exit the programming mode and return to the **MAIN SCREEN**.

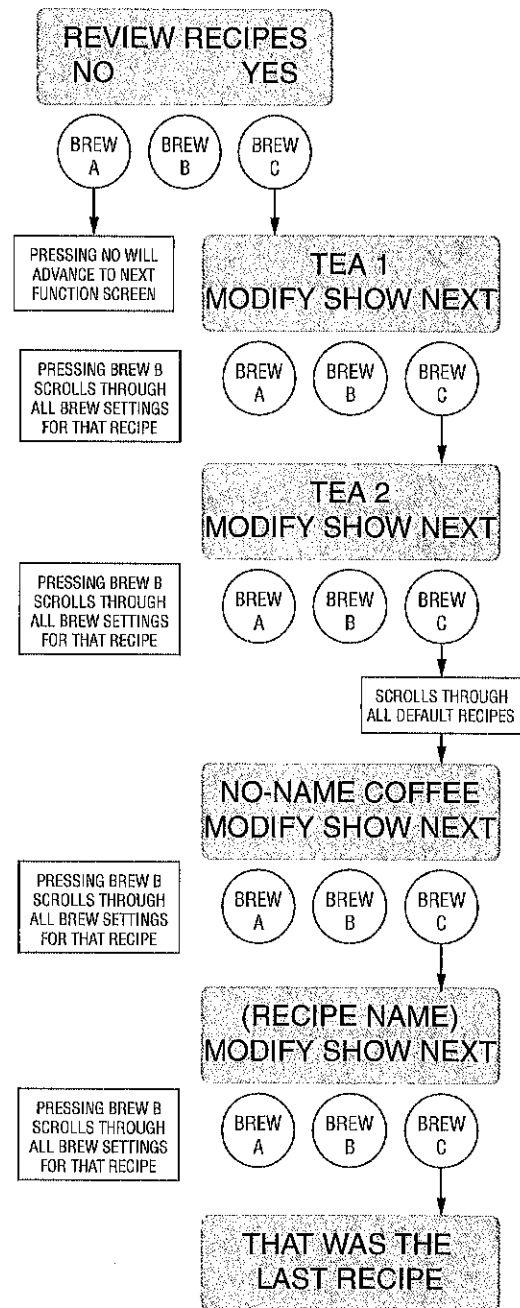

P2859

RECIPE CHART	
Tea 1	Iced Coffee
Tea 2	No Name Coffee
Tea 3	
Hot Tea	

PROGRAMMING THE BREWER (cont.)

PROGRAMMING FUNCTIONS - LEVEL 2 (cont.)

ASSIGN RECIPE

This function allows the operator to assign recipes to the three brew buttons. Standard recipes (TEA 1, TEA 2, TEA 3, HOT TEA, ICED COFFEE, NO-NAME COFFEE) and any saved recipes from a Smart Funnel or Recipe Card can be assigned to a brew button. Only one recipe per brew button is allowed, for a total three recipes available to brew.

NOTE: Factory Defaults assign the TEA 1 recipe to Brew A, HOT TEA recipe to Brew B, and NO-NAME COFFEE to Brew C.

Procedure to select switch recipes:

1. Press and hold the right hidden button until the display reads **SET LANGUAGE**. Press the right hidden button until the display reads **SELECT SWITCH RECIPE?** Press **YES**.
2. The display should now read **SELECT RECIPE BREW SWITCH A**, and then **TEA 1**.
3. Using **(-)** and **(+)**, scroll through the stored recipes in the brewer's memory until the desired recipe name is reached.
4. Press and release **DONE** to set that recipe for brew button A.
5. The display should now read **SELECT RECIPE BREW SWITCH B**, and then **HOT TEA**.
6. Using **(-)** and **(+)**, scroll through the stored recipes in the brewer's memory until the desired recipe name is reached.
7. Press and release **DONE** to set that recipe for brew button B.
8. The display should now read **SELECT RECIPE BREW SWITCH C**, and then **NO-NAME COFFEE**.
9. Using **(-)** and **(+)**, scroll through the stored recipes in the brewer's memory until the desired recipe name is reached.
10. Press and release **DONE** to set that recipe for brew button C.
11. The display should now read **REVIEW RECIPES**.

Procedure to disable a Brew Switch:

1. Follow the same procedure as above. When selecting the recipe for the brew switch to be disabled, use **(-)** and **(+)** to scroll until the display reads **DISABLED**.

2. Press and release **DONE** to disable that brew switch on that side.

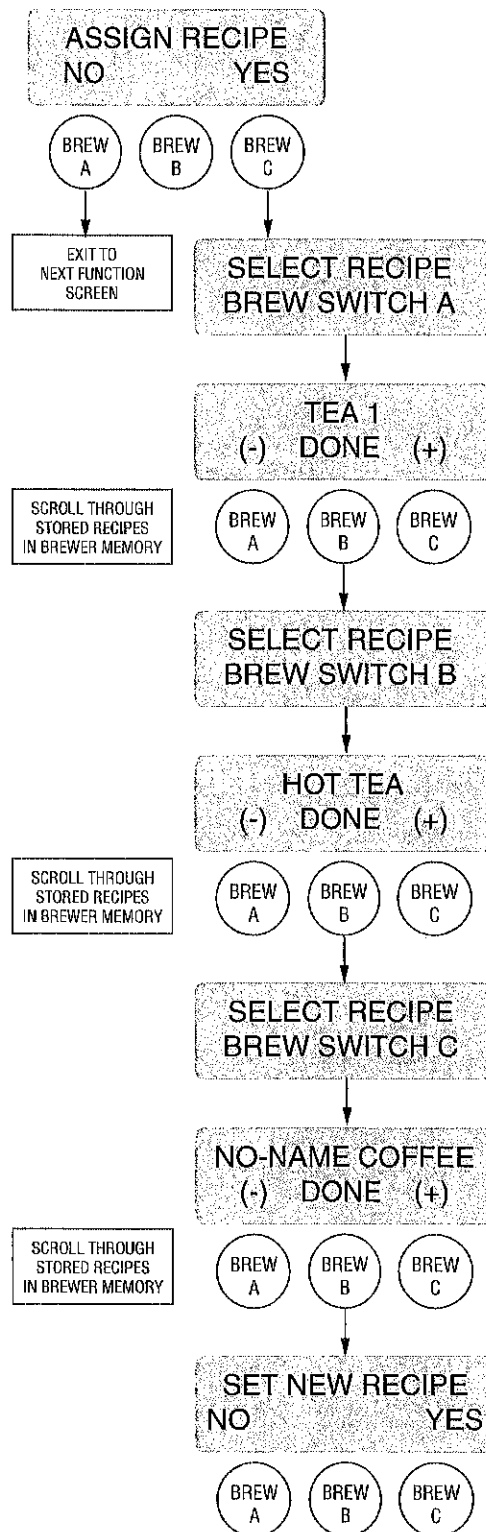

PROGRAMMING THE BREWER (cont.)

PROGRAMMING FUNCTIONS - LEVEL 2 (cont.)

SET NEW RECIPE (to set a new COFFEE recipe using a Smart Funnel or RECIPE CARD)

Using a Smart Funnel and a G9-2T DBC or MHG Grinder:

This function allows the operator to set **BREW VOLUMES, PULSE BREW TIMES AND DRIP OUT TIMES** for each coffee name preset in the grinder's memory.

Certain coffee names are stored in the grinder's memory. When a particular name of coffee is ground into the Smart Funnel, that name and the batch size selected are transferred from the grinder to the programming **CHIP** located in the funnel handle. The funnel is then inserted into the brewer's funnel rails. The **SENSING COIL** on the brewer reads the information contained in the handle. The name of the coffee flavor will then appear on the display. This allows the operator to set the **BREW VOLUME, PULSE BREW TIMES** and **DRIP OUT TIME** for that particular coffee name. It also allows the operator to set other brewing parameters, such as **BREW TEMPERATURE, BREW LOCKOUT**, etc. Each coffee name can be set individually to provide optimum brewing quality.

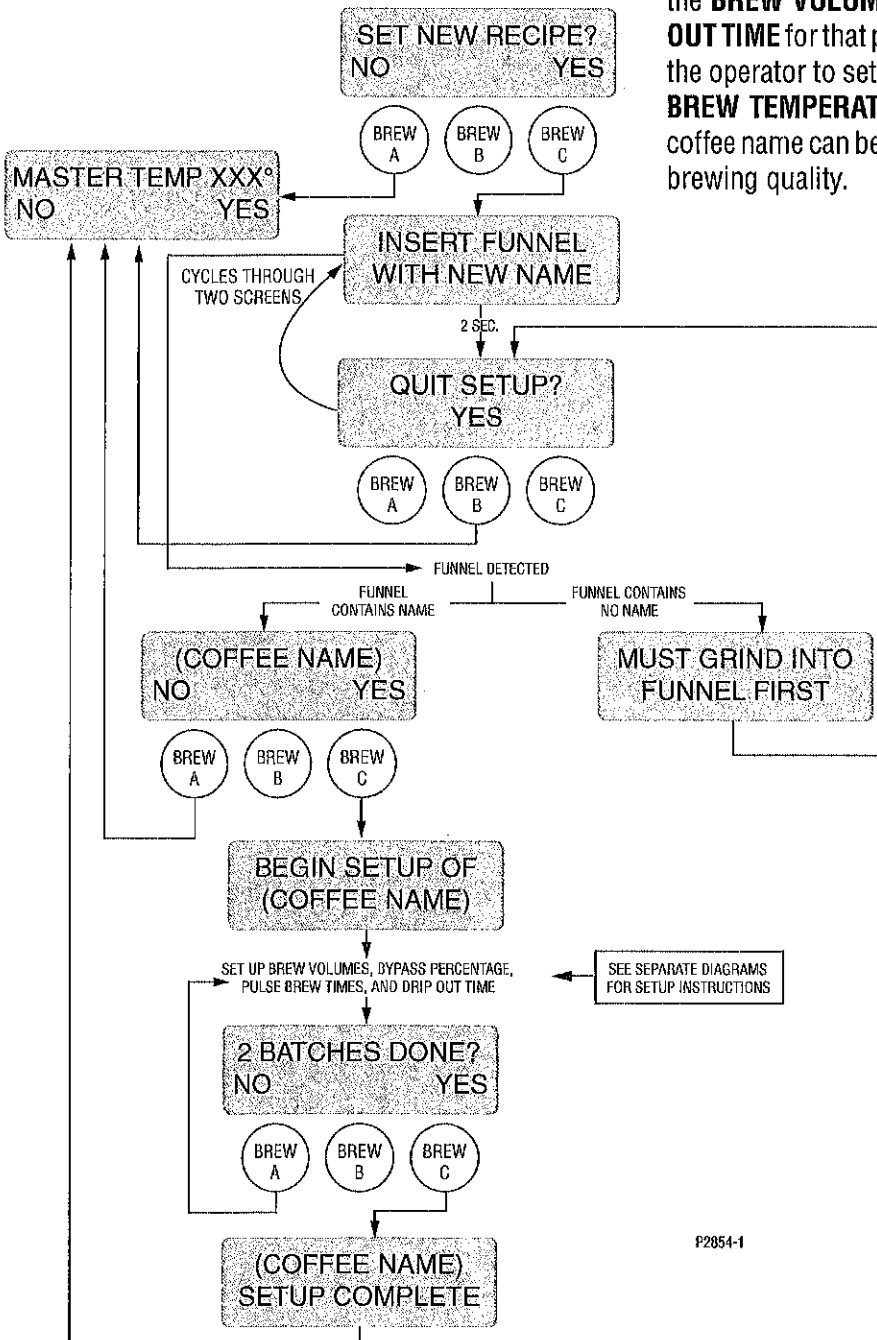

P2854-1

PROGRAMMING THE BREWER (cont.)

PROGRAMMING FUNCTIONS - LEVEL 2 (cont.)

Procedure for Setting the Recipe:

NOTE: Before beginning setup, place a server beneath the brew funnel.

1. Insert the funnel into the grinder and select the small batch size to grind. It is not necessary to have coffee beans in the hopper(s) in order to program the brewer. The coffee name is pre-selected and stored in the grinder's memory for the side being ground.
2. Press the GRIND pad. When the grinder stops grinding, remove the funnel.
3. On the brewer, press and hold the right hidden button until the display reads **SET LANGUAGE**. Press and release the right hidden button until the display reads **SET NEW RECIPE**. Release the right hidden button.
4. Press and release **YES**. The display should read **INSERT FUNNEL WITH NEW NAME**, then **QUIT SETUP?** These two displays will repeatedly cycle.
5. Insert the funnel into the rails on the brewer. The display should read the name of the coffee that was ground into the funnel, along with a **NO** and **YES**. If the name on the display is correct, press **YES**.
6. If, for some reason, the name of the coffee from the grinder did not load properly into the funnel, or if a grind has not yet been done, the display will read **MUST GRIND INTO FUNNEL FIRST**. It will be necessary to grind another batch following steps 1 and 2.

NOTE: If brewer memory is full, the display will read **RECIPE STORAGE AREA IS FULL** and then **REMOVE A FLAVOR?** To remove a recipe press and release **YES**. Press **NEXT** to scroll through the stored recipes. When the display reads the name of the recipe to be removed, press and release **REMOVE**. The display will read **REMOVE?** Press **CANCEL** to exit the **SET NEW RECIPE** function. Press **OK** to remove that recipe. The display will then show **BEGIN SETUP OF (COFFEE NAME)**. Continue with step 7.

7. If the grind is acknowledged by the brewer, the display will read **BEGIN SETUP OF (COFFEE NAME)**. Then the screen will display **BREW OZ** and a batch light will be blinking. (Refer to page 34 for description of **BREW OZ** function).
8. Using **(-)** and **(+)**, set the amount of brew water to be dispensed for that batch size.

9. When finished, press the other batch size and repeat step #8.
10. When finished setting both batch sizes, press and release **DONE**. The display should read **2 BATCHES DONE?**
11. If both batch sizes are not correct press and release **NO** to return to the **BREW OZ** setup screen and repeat steps #8, 9 and 10.
12. If both batch sizes are correct, press and release **YES** to advance to the **SET PULSE BREW** function. (Refer to page 35 for description of the **SET PULSE BREW** function).
13. To **SET PULSE BREW** press **YES** and proceed with the setup instructions for **SETTING PULSE BREW**, on page 35.
14. To skip setting the **PULSE BREW** and to use the **FACTORY DEFAULTS**, press **NO** to proceed to the **DRIP TIMES** function.

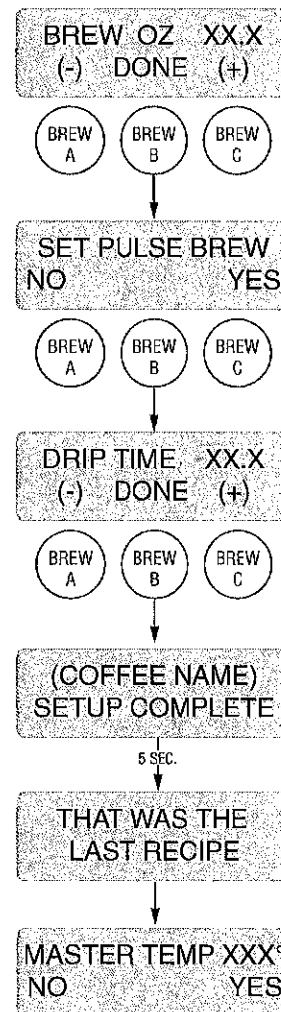

P2855

36748 051304

PROGRAMMING THE BREWER (cont.)

PROGRAMMING FUNCTIONS - LEVEL 2 (cont.)

15. The display should now read **DRIP TIME**, along with either the word **OFF** or a time showing. A batch light will also be blinking.
16. Using **(-)** and **(+)**, set the amount of time from when the brew spray ends to when the funnel is emptied of hot liquid.
17. When finished, press the other batch size and repeat step #16
18. When finished setting both batch sizes, press **DONE**. The display should read **2 BATCHES DONE?**
19. Press and release **YES**. The screen should show the name of the coffee being programmed (modified) along with **SETUP COMPLETE**.
20. After a 5 second delay, the display will advance to the next coffee name in the brewer's memory. If no other coffee names are present, the display will read **THAT WAS THE LAST RECIPE**, and advance to the **MASTER TEMP** screen.

SET NEW RECIPE

Using a **RECIPE CARD** to load coffee names and brew settings

The G9-2T DBC or MHG Grinder's memory contains certain coffee names. If the operator uses a coffee name that is not already stored in the grinder's memory, a **RECIPE CARD** can be obtained from the factory. The **RECIPE CARD** would include all the information needed to set up that particular coffee name. The information from the **RECIPE CARD** is loaded into the grinder's memory, then into the brewer's memory by holding the chip area up to the equipment's **SENSING COIL**. This information can include the coffee name, **BREW VOLUMES**, **PULSE BREW TIMES** and **DRIP OUT TIME** for that particular coffee name. These can all be loaded in seconds.

Contact Bunn-O-Matic Corporation for the availability of **RECIPE CARDS**.

NOTE: Instructions to program the brewer and grinder are printed on the **RECIPE CARD**, along with the coffee name that is being programmed.

Procedure to program the coffee name:

1. Remove the funnel (if present) from the funnel rails.

2. Position the **RECIPE CARD** vertically, so that the top end of the **CHIP** is beneath the **SENSING COIL** (located on the middle of the underneath side of the front display panel).
3. After a short pause the display will read **CARD CONTAINS RECIPE FOR** then will change to **(COFFEE NAME) SHOW QUIT SAVE**. All brewing parameters for that coffee flavor are now transferred from the **CARD** to the brewer.

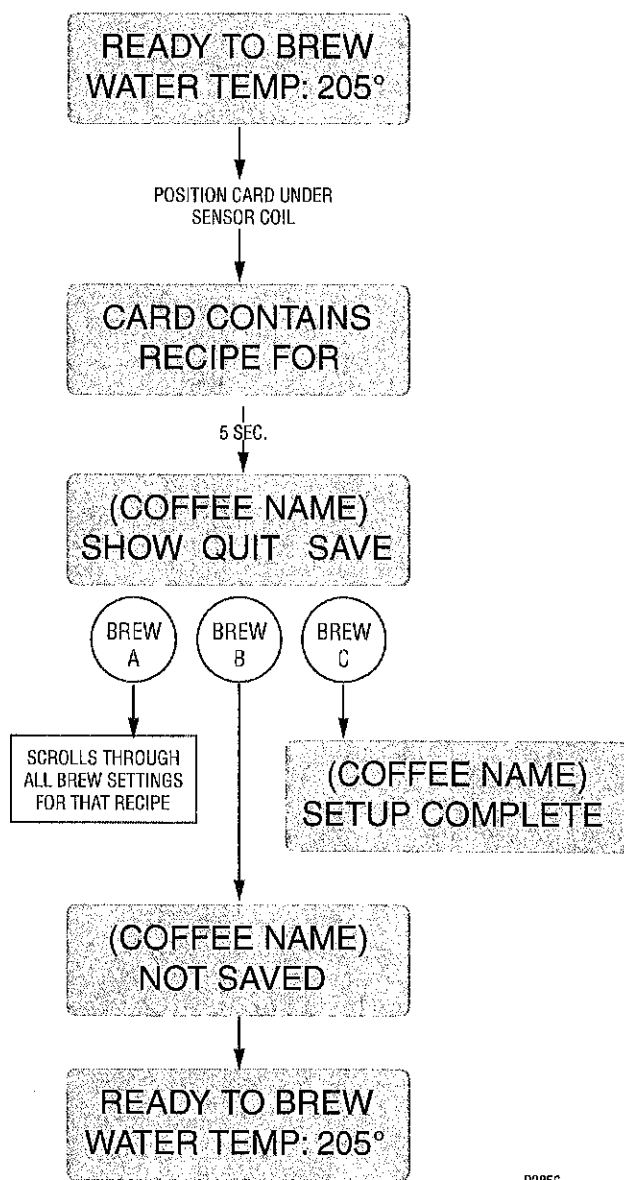

P2856

PROGRAMMING THE BREWER (cont.)

PROGRAMMING FUNCTIONS - LEVEL 2 (cont.)

4. To show (view) this information, press and release **SHOW**. The display will scroll through all of the brew settings for that recipe. This display will then return to **CARD CONTAINS RECIPE FOR** then will change to **(COFFEE NAME) SHOW QUIT SAVE**.
5. If all brew settings are correct, press **SAVE**. The display will read **(COFFEE NAME) SETUP COMPLETE**. All brew settings for that name are now stored in the brewer's memory.
6. If the brewing information is not correct, or it is desired to exit the setup before the settings are loaded into the brewer's memory, press **QUIT**. The display will read **(COFFEE NAME) NOT SAVED**. The display will then return to the **MAIN SCREEN**.

SET NEW RECIPE

If not using a Smart Funnel and/or a G9-2T DBC or MGH Grinder and/or a Recipe Card

It is possible to operate the brewer without using a Smart Funnel and/or G9-2T DBC or MGH Grinder. If a standard funnel or if a non-DBC grinder is used the brewer will automatically select the recipe assigned to that brew button. This means that no name was read from the funnel's handle.

For instructions on programming the **NO-NAME COFFEE** settings, refer to the **REVIEW RECIPES** function on page 34. The same steps are followed for setting the **NO-NAME COFFEE** recipe as those that are used to modify a recipe. Note that when the display reads **NO-NAME COFFEE**, that is when **MODIFY** should be pressed in order to set the parameters.

NOTE: Before beginning setup, insert a funnel into the funnel rails and place a server or dispenser beneath the brew funnel.

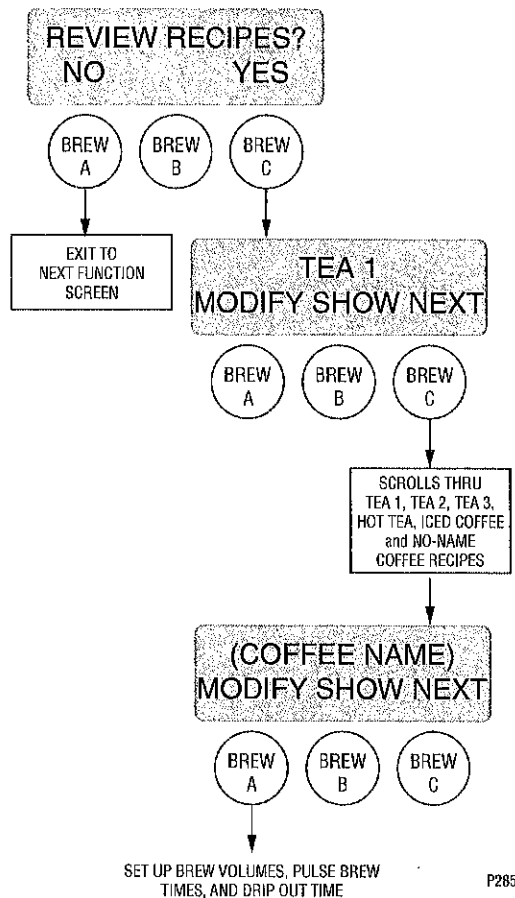

P2857

PROGRAMMING THE BREWER (cont.)

PROGRAMMING FUNCTIONS - LEVEL 2 (cont.)

Procedure for modifying TEA recipes:

Tea recipes: BREW OZ:

Range: OFF, 10.0 oz to 135.0 oz (.3-4.0 L) for both batch sizes

This function allows adjustment of the brew (tea concentrate) volumes for each batch.

1. Press and hold the right hidden button until the display reads **SET LANGUAGE**. Press the right hidden button until the display reads **REVIEW RECIPES**.
2. Press **YES** to proceed. The display should now read **TEA 1**, along with **MODIFY SHOW NEXT**.
3. Press and release **NEXT** to advance to the desired recipe to be modified.
4. Press and release **MODIFY**. The display should read **BREW OZ:** and a batch light will be blinking. Press and release the batch size to be modified.
5. Using **(-)** and **(+)**, set the amount of brew water to be dispensed **over** the tea leaves for that particular batch size.
6. When finished, press the other batch size and repeat step #5.
7. When finished setting both batch sizes, press and release **DONE**. The display should read **2 BATCHES DONE?**
8. If both batch sizes are not correct, press and release **NO** to return to the **BREW OZ:** setup screen and repeat steps #5, 6, and 7.
9. If both batch sizes are correct, press **YES**. This will advance to the **DILUTE OZ:** function. To exit to the **MAIN SCREEN**, press and release the ON/OFF button.

Procedure to disable a batch size:

1. Follow same procedure as above. Select the batch size to be disabled.
2. Using **(-)** and **(+)**, scroll until the display reads **BREW OZ OFF**.
3. Press and release **DONE**. This will disable this batch size for that recipe.

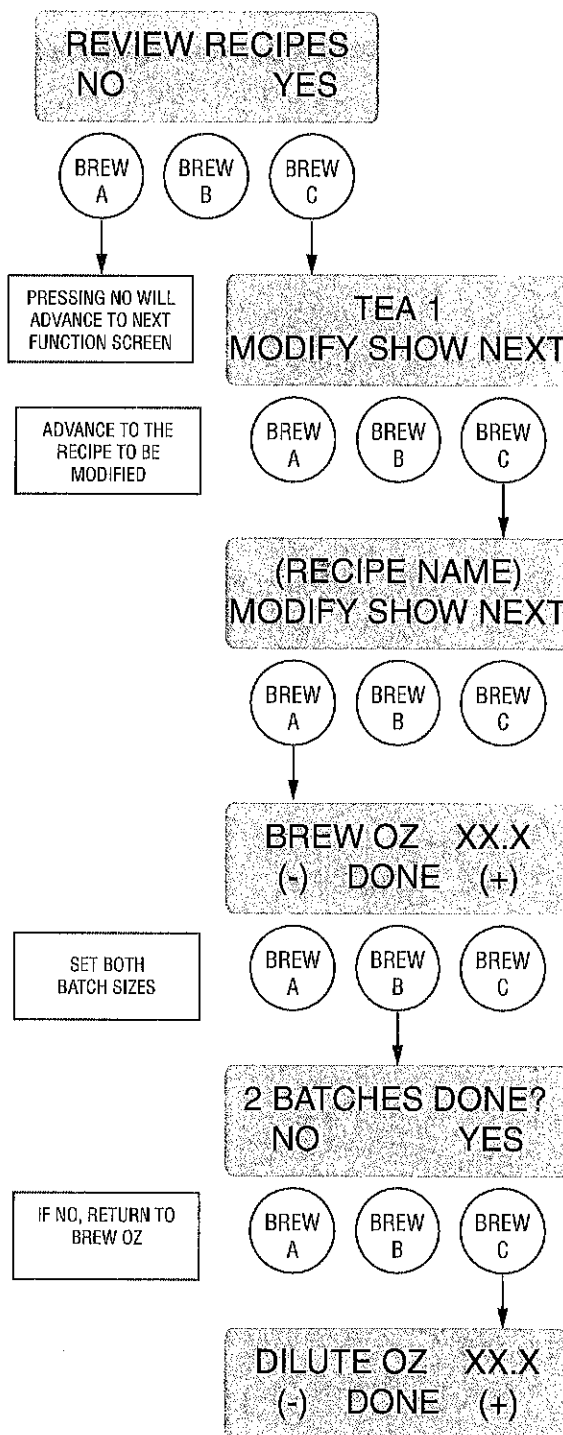

P2860

PROGRAMMING THE BREWER (cont.)

PROGRAMMING FUNCTIONS - LEVEL 2 (cont.)

Tea recipes: **DILUTE OZ:**

Range: 0.0 oz to 580.0 oz (0-17.1 L) for both batch sizes

This function allows adjustment of the dilution volumes for each batch.

NOTE: If the brewer is already on the **DILUTE OZ:** screen, skip steps 1 through 6, and proceed directly to step 7.

1. Press and hold the right hidden button until the display reads **SET LANGUAGE**. Press the right hidden button until the display reads **REVIEW RECIPES**.
2. Press **YES** to proceed. The display should now read **TEA 1**, along with **MODIFY SHOW NEXT**.
3. Press and release **NEXT** to advance to the desired recipe to be modified.
4. Press and release **MODIFY**. The display should read **BREW OZ:**
5. Press and release **DONE**. The display should read **2 BATCHES DONE?**
6. Press and release **YES**. The display should now read **DILUTE OZ:** and a batch light will be blinking. Press and release the batch size to be modified.
7. Using **(-)** and **(+)**, set the amount of dilution water for that particular batch size to be dispensed through the nozzle into the tea dispenser.
8. When finished, press the other batch size and repeat step # 7.
9. When finished setting both batch sizes, press and release **DONE**. The display should read **2 BATCHES DONE?**
10. If both batch sizes are not correct, press and release **NO** to return to the **DILUTE OZ:** setup screen and repeat steps 7, 8 and 9.
11. If both batch sizes are correct, press **YES**. This will advance to the **DILUTE DELY** function. To exit to the **MAIN SCREEN**, press and release the ON/OFF button.

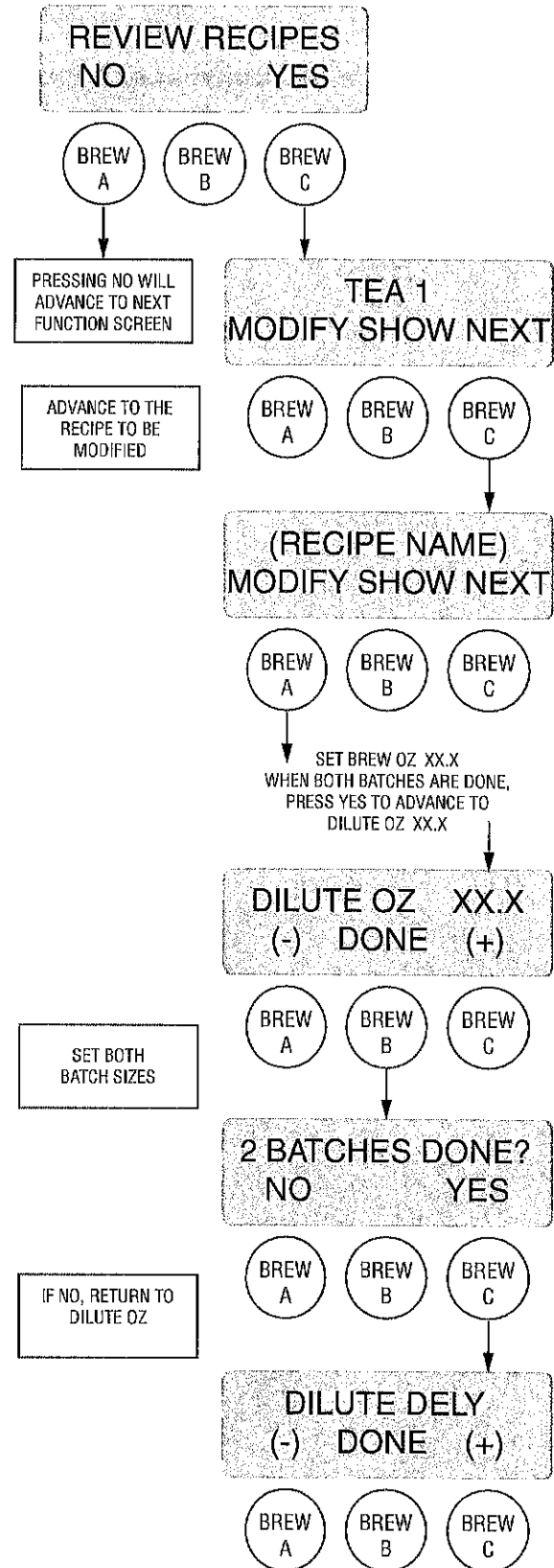

P2861

PROGRAMMING THE BREWER (cont.)

PROGRAMMING FUNCTIONS - LEVEL 2 (cont.)

Tea recipes: DILUTE DELAY

Range: OFF to 10 minutes for both batch sizes

This function allows the operator to adjust the timing for the start of the dilution water. The **OFF** setting will begin dilution flow immediately after the brew button is pressed (simultaneously with the brew water). If a time is set for Dilution Delay, the dilution water dispense will be delayed for that set time after the brew button is pressed and the brew started.

NOTE: If the brewer is already on the **DILUTE DELY** screen, skip steps 1 through 8, and proceed directly to step 9.

1. Press and hold the right hidden button until the display reads **SET LANGUAGE**. Press the right hidden button until the display reads **REVIEW RECIPES**.
2. Press **YES** to proceed. The display should now read **TEA 1**, along with **MODIFY SHOW NEXT**.
3. Press and release **NEXT** to advance to the desired tea recipe to be modified.
4. Press and release **MODIFY**. The display should read **BREW OZ:**
5. Press and release **DONE**. The display should read **2 BATCHES DONE?**
6. Press and release **YES**. The display should now read **DILUTE OZ:**
7. Press and release **DONE**. The display should read **2 BATCHES DONE?**
8. Press and release **YES**. The display should now read **DILUTE DELY:** and a batch light will be blinking. Press and release the batch size to be modified.
9. Using **(-)** and **(+)**, set the time delay for the dilution water for that particular batch size.
10. When finished, press the other batch size and repeat step # 9.
11. When finished setting both batch sizes, press and release **DONE**. The display should read **2 BATCHES DONE?**
12. If both batch sizes are not correct, press and release **NO** to return to the **DILUTE DELY** setup screen and repeat steps 9, 10 and 11.
13. If both batch sizes are correct, press **YES**. The display should now show the Brew Oz, Dilution Oz, and Dilution Delay setting for the batch size just programmed. After a 5 second delay, the display will read **SET PULSE BREW**. To exit to the **MAIN SCREEN**, press and release the ON/OFF button.

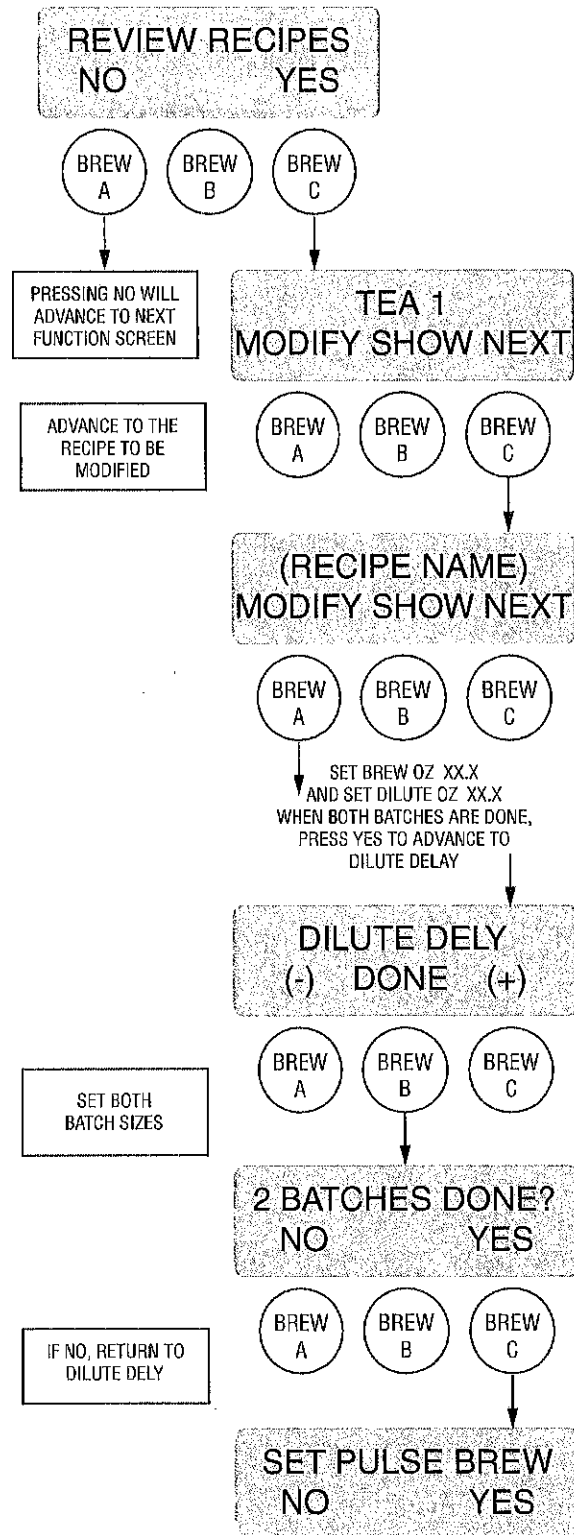

P2862

PROGRAMMING THE BREWER (cont.)

PROGRAMMING FUNCTIONS - LEVEL 2 (cont.)

TEA RECIPES:

SET PULSE BREW

This function allows the operator to program the brewer to “pulse” the sprayhead flow on and off during a brew cycle (start and stop the flow of water out of the sprayhead). This feature allows the ability to “fine-tune” the brewer for specific flavor profiles. Pulse brewing can be set up for any and all batch sizes.

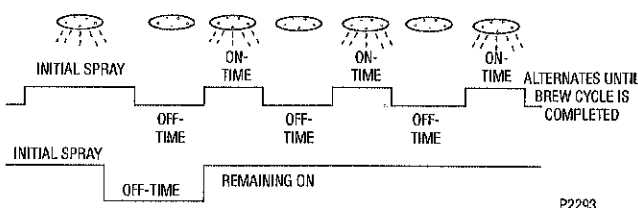

- a) **1st ON TIME** – This time is the duration from when the brew button is pressed to when the desired water level in the funnel is reached. (Soaking the tea leaves)
- b) **OFF-TIME** – This time is the duration from when the water in the funnel reaches the desired **ON TIME** to when it drains out of the funnel to a desired lower level.
- c) **LAST ON-TIME** – This time is the duration from when the water in the funnel drains down to the lower level to when it fills the funnel to a desired higher level. (Soaking the tea leaves)

These three times can be set two different ways. The first is by setting the total brew time and using a calculated pulse routine. This is done by utilizing the **EASY PULSE BREW** screen and following the setup for that function.

Setting Pulse Brew – EASY Pulse Brew

Range: Minimum: will adjust to the minimum time required to brew that batch using the set brew volumes and flow rate for the sprayhead. Maximum – will adjust depending on settings. Will always be minimum time + 3 minutes. The brewer will automatically calculate what the **1ST ON TIME**, **OFF TIMES**, and **LAST ON TIME** will be using the initial on time, plus a 7 pulse routine.

The other option allows the actual times to be entered for each of the settings. This is done by utilizing the **MANUAL PULSE BREW** screen and following the subsequent steps under that function.

Setting Pulse Brew – MANUAL Pulse Brew

Range: **1ST ON TIME** – off to 1 minute
OFF TIME – off to 20 seconds
LAST ON TIME – Pre-Infusion to 1 minute

PROGRAMMING THE BREWER (cont.)

PROGRAMMING FUNCTIONS - LEVEL 2 (cont.)

Setting Pulse Brew – EASY Pulse Brew

NOTE: If the brewer is already on the **SET PULSE BREW** screen, skip steps 1 through 9, and proceed directly to step 10.

1. Press and hold the right hidden button until the display reads **SET LANGUAGE**. Press the right hidden button until the display reads **REVIEW RECIPES**.
2. Press **YES** to proceed. The display should now read **TEA 1**, along with **MODIFY SHOW NEXT**.
3. Press and release **NEXT** to advance to the desired recipe to be modified.
4. Press and release **MODIFY**. The display should read **BREW OZ:**
5. Press and release **DONE**. The display should read **2 BATCHES DONE?**
6. Press and release **YES**. The display should now read **DILUTE OZ:**
7. Press and release **DONE**. The display should read **2 BATCHES DONE?**
8. Press and release **YES**. The display should now read **DILUTE DELY:**
9. Press and release **DONE**. The display should now show the Brew Oz, Dilution Oz, and Dilution Delay setting for the batch size just programmed. After a 5 second delay, the display will read **SET PULSE BREW**.
10. Press and release **YES**. The display should now read **SELECT METHOD**.
11. Press and release **EASY**. With EASY flashing, press and release **NEXT** to advance.
12. The display should now read **BREW TIME:** and a batch light will be blinking. Press and release the batch size to be modified.
13. Using **(-)** and **(+)**, set the total brew time desired including spray times and off times.
14. When finished, press the other batch size and repeat step # 13.
15. When finished setting both batch sizes, press and release **DONE**. The display will show the pulse settings to accommodate the brew time entered. Press and release each batch size to display the settings for that batch. After a delay, the display should read **2 BATCHES DONE?**
16. If both batch sizes are not correct, press and release **NO** to return to the **BREW TIME** setup screen and repeat steps 13, 14 and 15.

17. If both batch sizes are correct, press **YES**. The display should now read **DRIP TIME:**. To exit to the **MAIN SCREEN**, press and release the **ON/OFF** button.

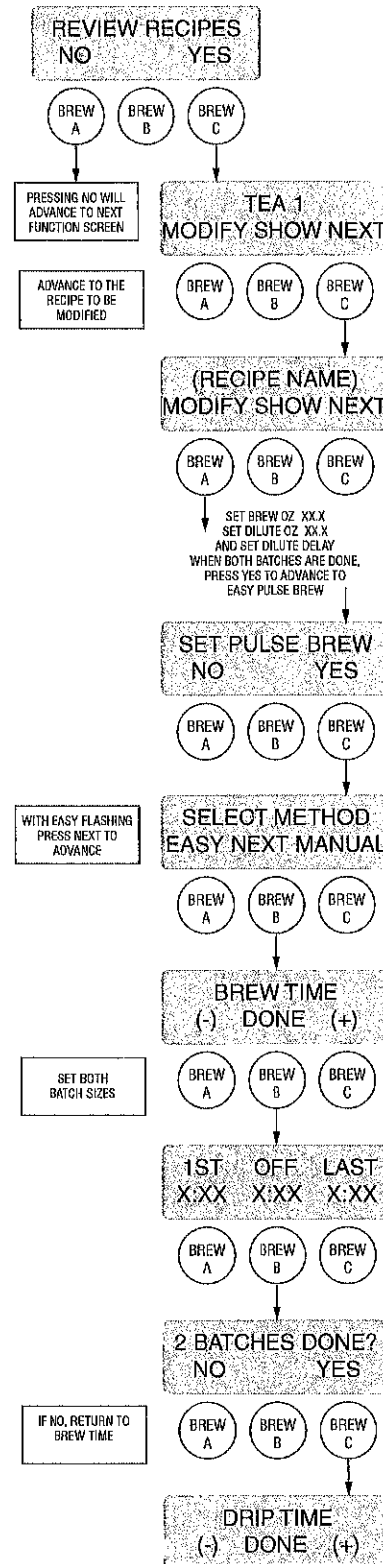

PROGRAMMING THE BREWER (cont.)

PROGRAMMING FUNCTIONS - LEVEL 2 (cont.)

Setting Pulse Brew – MANUAL Pulse Brew

NOTE: If the brewer is already on the **SET PULSE BREW** screen, skip steps 1 through 9, and proceed directly to step 10.

1. Press and hold the right hidden button until the display reads **SET LANGUAGE**. Press the right hidden button until the display reads **REVIEW RECIPES**.
2. Press **YES** to proceed. The display should now read **TEA 1**, along with **MODIFY SHOW NEXT**.
3. Press and release **NEXT** to advance to the desired recipe to be modified.
4. Press and release **MODIFY**. The display should read **BREW OZ:**
5. Press and release **DONE**. The display should read **2 BATCHES DONE?**
6. Press and release **YES**. The display should now read **DILUTE OZ:**
7. Press and release **DONE**. The display should read **2 BATCHES DONE?**
8. Press and release **YES**. The display should now read **DILUTE DELY:**
9. Press and release **DONE**. The display should now show the Brew Oz, Dilution Oz, and Dilution Delay setting for the batch size just programmed. After a 5 second delay, the display will read **SET PULSE BREW**.
10. Press and release **YES**. The display should now read **SELECT METHOD**.
11. Press and release **MANUAL**. With **MANUAL** flashing, press and release **NEXT**.
12. The display should now read **1ST ON TIME** and a batch light will be blinking. Press and release the batch size to be modified.
13. Using **(-)** and **(+)**, adjust the **1ST ON TIME**.
14. When finished, press the other batch size and repeat step # 13.
- NOTE:** To disable pulse brew, set **1ST ON TIME** to **OFF**. Brewer will automatically pulse on tea recipes with a brew volume greater than 86.0 oz.
15. When finished setting both batch sizes, press and release **DONE**.
16. The display should now read **OFF TIME**. Adjust the **OFF TIME** using **(-)** and **(+)**.
17. When finished, press the other batch size and repeat step # 16.
18. When finished setting both batch sizes, press and release **DONE**.
19. The display should now read **LAST ON:**. Adjust the **LAST ON TIME** using **(-)** and **(+)**. If **PREINFUSION** is desired, set the **LAST ON TIME** to **PreI**.
20. When finished, press the other batch size and repeat step # 19.
21. When finished setting both batch sizes, press and release **DONE**.
22. The display will show the three times just entered. Press and release each batch size to display the settings for that batch. If the **1ST ON TIME** is set to **OFF**, the display will read **PULSE BREW DISABLED**. After a 5 second delay, the display will read **2 BATCHES DONE?**
23. If both the pulse brew settings for both batch sizes are not correct, press and release **NO** to return to the **1ST ON TIME** setup screen and repeat steps 13 through 22.
24. If both batch sizes are correct, press **YES**. The display should now read **DRIP TIME**. To exit to the **MAIN SCREEN**, press and release the **ON/OFF** button.

PROGRAMMING THE BREWER (cont.)

PROGRAMMING FUNCTIONS - LEVEL 2 (cont.)

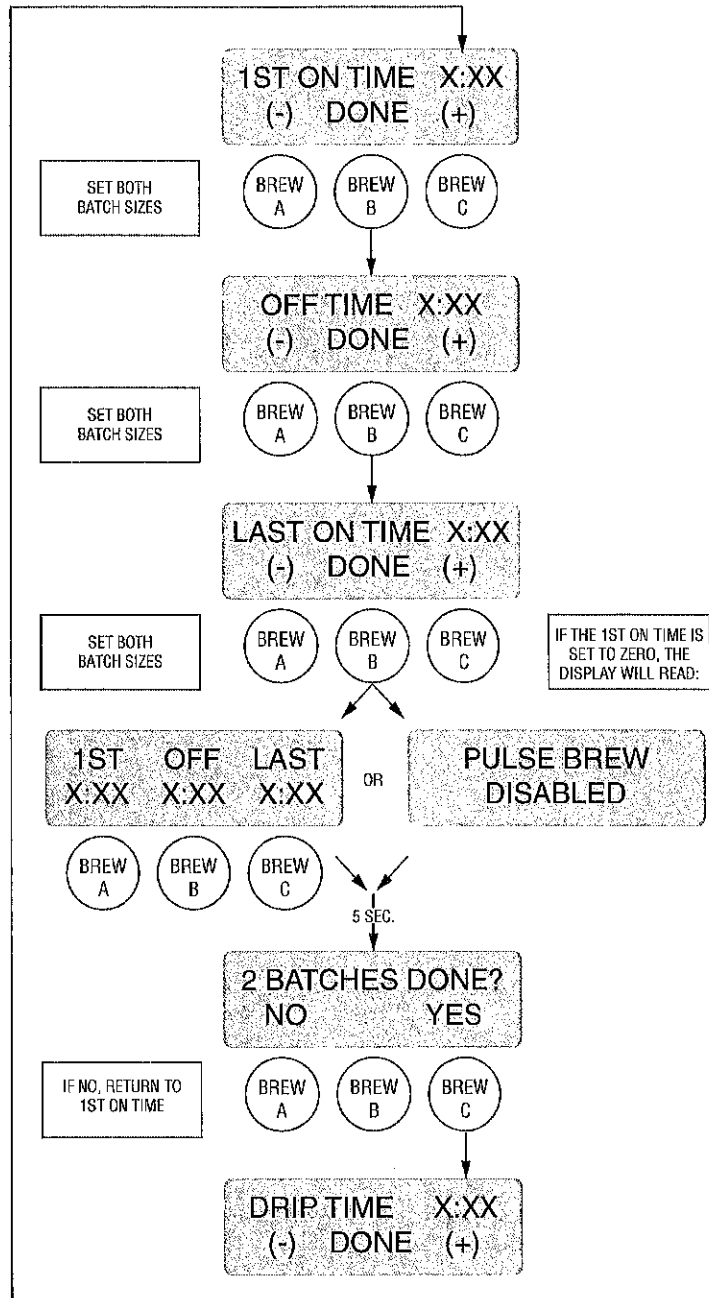
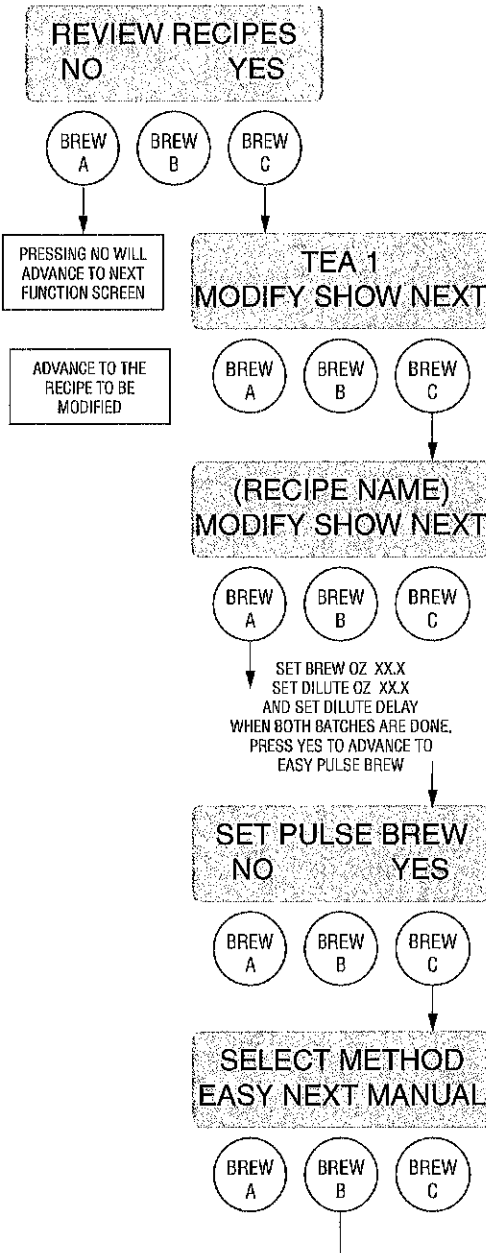

PROGRAMMING THE BREWER (cont.)

PROGRAMMING FUNCTIONS - LEVEL 2 (cont.)

TEA RECIPES:

DRIP TIME

This function allows the operator to adjust the **DRIP TIME** (time from end of sprayhead flow to when liquid stops dripping from the funnel). When the brew cycle is complete, the display will show **DRIPPING** and will countdown the time until the funnel empties.

Setting DRIP TIME:

Range: OFF to 5 minutes for all batch sizes.

NOTE: If the brewer is already in the **DRIP TIME** screen, skip steps 1 through 10 and proceed directly to step 11.

1. Press and hold the right hidden button until the display reads **SET LANGUAGE**. Press the right hidden button until the display reads **REVIEW RECIPES**.
2. Press **YES** to proceed. The display should now read **TEA 1**, along with **MODIFY SHOW NEXT**.
3. Press and release **NEXT** to advance to the desired recipe to be modified.
4. Press and release **MODIFY**. The display should read **BREW OZ:**
5. Press and release **DONE**. The display should read **2 BATCHES DONE?**
6. Press and release **YES**. The display should now read **DILUTE OZ:**
7. Press and release **DONE**. The display should read **2 BATCHES DONE?**
8. Press and release **YES**. The display should now read **DILUTE DELY:**
9. Press and release **DONE**. The display should now show the Brew Oz, Dilution Oz, and Dilution Delay setting for the batch size just programmed. After a 5 second delay, the display will read **SET PULSE BREW**.
10. Press and release **NO**. The display should now read **DRIP TIME** and a batch light should be flashing.
11. Using the **(-)** and **(+)**, set the amount of time from when the brew solenoid shuts off to when drip-out occurs for that batch size.
12. When finished, press the other batch size and repeat step 11.
13. When finished, press **DONE**. The display should read **2 BATCHES DONE?**

14. If both batch sizes are not correct, press and release **NO** to return to the **DRIP TIME** setup screen and repeat steps 11 through 13.
15. If both batch sizes are correct, press **YES**. The display should show the name of the recipe being programmed (modified) along with **SETUP COMPLETE**. After a 5 second delay, the display will advance to the next recipe name in the brewer's memory. To exit to the **MAIN SCREEN**, press and release the ON/OFF button.

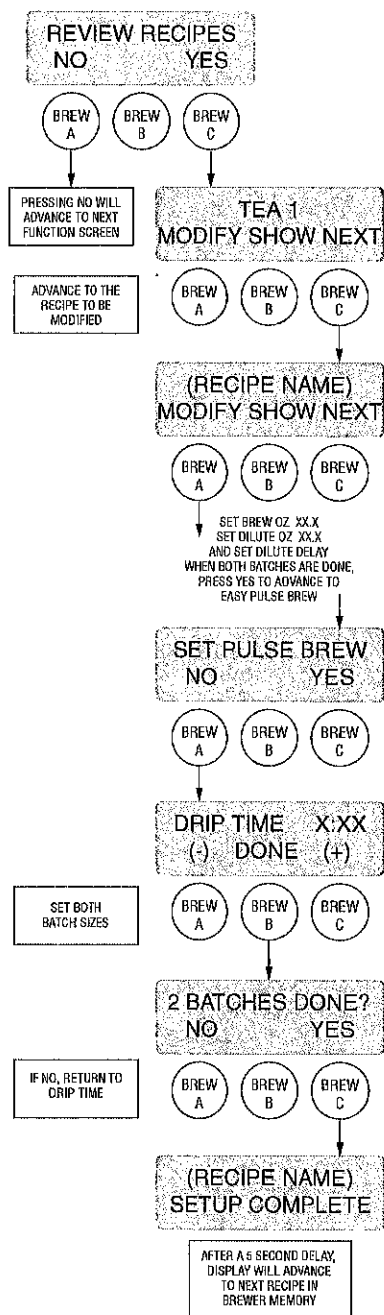

P2865

PROGRAMMING THE BREWER (cont.)

PROGRAMMING FUNCTIONS - LEVEL 2 (cont.)

Procedure for modifying COFFEE recipes:

Coffee recipes: **BREW OZ:**

Range: **OFF 10.0 oz to 135.0 oz (0.0-4.0L)** for both batch sizes

This function allows adjustment of the brew volumes for each batch.

1. Press and hold the right hidden button until the display reads **SET LANGUAGE**. Press the right hidden button until the display reads **REVIEW RECIPES**.
2. Press **YES** to proceed. The display should now read **TEA 1**, along with **MODIFY SHOW NEXT**.
3. Press and release **NEXT** to advance to the desired coffee recipe to be modified.
4. Press and release **MODIFY**. The display should read **BREW OZ:** and a batch light will be blinking. Press and release the batch size to be modified.
5. Using **(-)** and **(+)**, set the amount of brew water to be dispensed **over** the grounds for that particular batch size.
6. When finished, press the other batch size and repeat step #5.
7. When finished setting both batch sizes, press and release **DONE**. The display should read **2 BATCHES DONE?**
8. If both batch sizes are not correct, press and release **NO** to return to the **BREW OZ:** setup screen and repeat steps #5, 6, and 7.
9. If both batch sizes are correct, press **YES**. This will advance to **SET PULSE BREW**. To exit to the **MAIN SCREEN**, press and release the ON/OFF button.

Procedure to disable a batch size:

1. Follow same procedure as above. Select the batch size to be disabled.
2. Using **(-)** and **(+)**, scroll until the display reads **BREW OZ OFF**.
3. Press and release **DONE**. This will disable this batch size for that recipe.

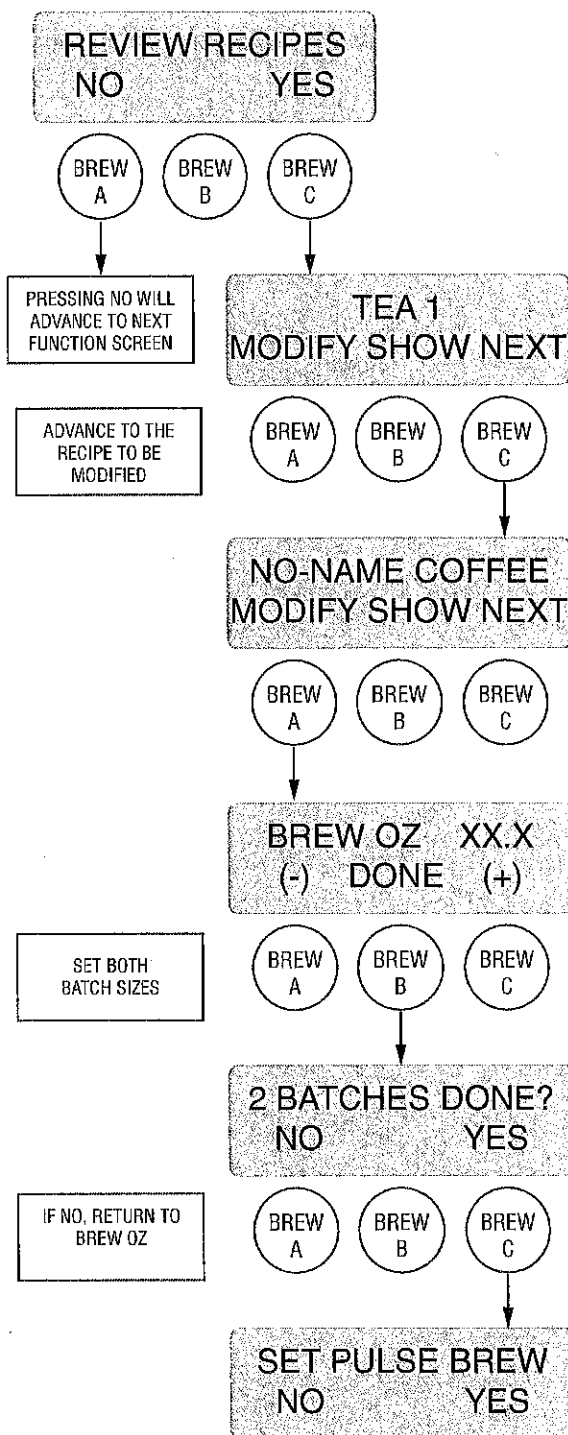

P2866

PROGRAMMING THE BREWER (cont.)

PROGRAMMING FUNCTIONS - LEVEL 2 (cont.)

COFFEE RECIPES:

SET PULSE BREW

This function allows the operator to program the brewer to “pulse” the sprayhead flow on and off during a brew cycle (start and stop the flow of water out of the sprayhead). This feature allows the ability to “fine-tune” the brewer for specific flavor profiles. Pulse brewing can be set up for any and all batch sizes.

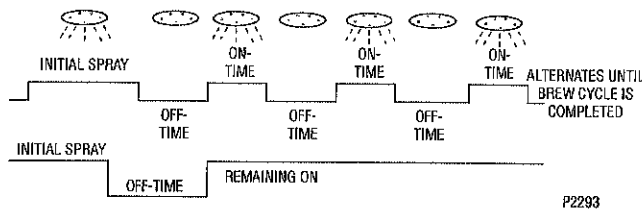

- a) **1st ON TIME** – This time is the duration from when the brew button is pressed to when the desired water level in the funnel is reached. (Soaking the grounds)
- b) **OFF-TIME** – This time is the duration from when the water in the funnel reaches the desired **ON TIME** to when it drains out of the funnel to a desired lower level.
- c) **LAST ON-TIME** – This time is the duration from when the water in the funnel drains down to the lower level to when it fills the funnel to a desired higher level. (Soaking the grounds)

These three times can be set two different ways. The first is by setting the total brew time and using a calculated pulse routine. This is done by utilizing the **EASY PULSE BREW** screen and following the setup for that function.

Setting Pulse Brew – EASY Pulse Brew

Range: **Minimum:** will adjust to the minimum time required to brew that batch using the set brew volumes and flow rate for the sprayhead. **Maximum** – will adjust depending on settings. Will always be minimum time + 3 minutes. The brewer will automatically calculate what the **1ST ON TIME**, **OFF TIMES**, and **LAST ON TIME** will be using the initial on time, plus a 7 pulse routine.

The other option allows the actual times to be entered for each of the settings. This is done by utilizing the **MANUAL PULSE BREW** screen and following the subsequent steps under that function.

Setting Pulse Brew – MANUAL Pulse Brew

Range: **1ST ON TIME – OFF** to 4 minutes

OFF TIME – OFF to 4 minutes

LAST ON TIME – Pre-Infusion to 4 minutes

PROGRAMMING THE BREWER (cont.)

PROGRAMMING FUNCTIONS - LEVEL 2 (cont.)

Setting Pulse Brew – EASY Pulse Brew

NOTE: If the brewer is already on the **SET PULSE BREW** screen, skip steps 1 through 6, and proceed directly to step 7.

1. Press and hold the right hidden button until the display reads **SET LANGUAGE**. Press the right hidden button until the display reads **REVIEW RECIPES**.
2. Press **YES** to proceed. The display should now read **TEA 1**, along with **MODIFY SHOW NEXT**.
3. Press and release **NEXT** to advance to the desired coffee recipe to be modified.
4. Press and release **MODIFY**. The display should read **BREW OZ:**
5. Press and release **DONE**. The display should read **2 BATCHES DONE?**
6. Press and release **YES**. The display should now read **SET PULSE BREW**.
7. Press and release **YES**. The display should now read **SELECT METHOD**.
8. Press and release **EASY**. With EASY flashing, press and release **NEXT** to advance.
9. The display should now read **BREW TIME:** and a batch light will be blinking. Press and release the batch size to be modified.
10. Using **(-)** and **(+)**, set the total brew time desired including spray times and off times.
11. When finished, press the other batch size and repeat step # 10.
12. When finished setting both batch sizes, press and release **DONE**. The display should read **2 BATCHES DONE?**
13. If both batch sizes are not correct, press and release **NO** to return to the **BREW TIME** setup screen and repeat steps 10, 11 and 12.
14. If both batch sizes are correct, press **YES**. The display will show the pulse settings to accommodate the brew time entered. Press and release each batch size to display the settings for that batch. After a delay, the display should now read **DRIP TIME:**. To exit to the **MAIN SCREEN**, press and release the **ON/OFF** button.

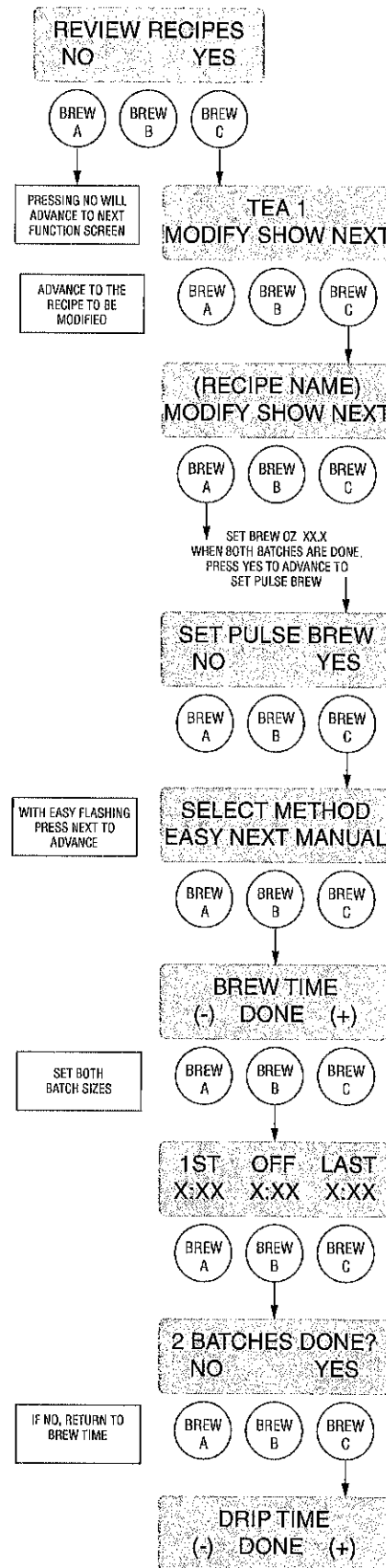

P2867

PROGRAMMING THE BREWER (cont.)

PROGRAMMING FUNCTIONS - LEVEL 2 (cont.)

Setting Pulse Brew – MANUAL Pulse Brew

NOTE: If the brewer is already on the **SET PULSE BREW** screen, skip steps 1 through 6, and proceed directly to step 7.

1. Press and hold the right hidden button until the display reads **SET LANGUAGE**. Press the right hidden button until the display reads **REVIEW RECIPES**.
 2. Press **YES** to proceed. The display should now read **TEA 1**, along with **MODIFY SHOW NEXT**.
 3. Press and release **NEXT** to advance to the desired coffee recipe to be modified.
 4. Press and release **MODIFY**. The display should read **BREW OZ:**
 5. Press and release **DONE**. The display should read **2 BATCHES DONE?**
 6. Press and release **YES**. The display should now read **SET PULSE BREW**.
 7. Press and release **YES**. The display should now read **SELECT METHOD**.
 8. Press and release **MANUAL**. With **MANUAL** flashing, press and release **NEXT**.
 9. The display should now read **1ST ON TIME** and a batch light will be blinking. Press and release the batch size to be modified.
 10. Using (-) and (+), adjust the **1ST ON TIME**.
 11. When finished, press the other batch size and repeat step # 10.
 12. When finished setting both batch sizes, press and release **DONE**.
 13. The display should now read **OFF TIME**. Adjust the **OFF TIME** using (-) and (+).
 14. When finished, press the other batch size and repeat step # 13.
- NOTE:** To disable pulse brew, set **1ST ON TIME** to OFF. For recipes with a brew volume greater than 86.0 oz. and pulse brew disabled, the following message will appear after the **BREW** button is pressed, **COFFEE FUNNEL?...PRESS BREW "X"**.
15. When finished setting both batch sizes, press and release **DONE**.
 16. The display should now read **LAST ON:**. Adjust the **LAST ON TIME** using (-) and (+). If **PREINFUSION** is desired, set the **LAST ON TIME** to **Prel**.
 17. When finished, press the other batch size and repeat step # 16.
 18. When finished setting both batch sizes, press and release **DONE**.
 19. The display will show the three times just entered. Press and release each batch size to display the settings for that batch. If the **1ST ON TIME** is set to **OFF**, the display will read **PULSE BREW DISABLED**. After a 5 second delay, the display will read **2 BATCHES DONE?**
 20. If both the pulse brew settings for both batch sizes are not correct, press and release **NO** to return to the **1ST ON TIME** setup screen and repeat steps 10 through 19.
 21. If both batch sizes are correct, press **YES**. The display should now read **DRIP TIME**. To exit to the **MAIN SCREEN**, press and release the **ON/OFF** button.

PROGRAMMING THE BREWER (cont.)

PROGRAMMING FUNCTIONS - LEVEL 2 (cont.)

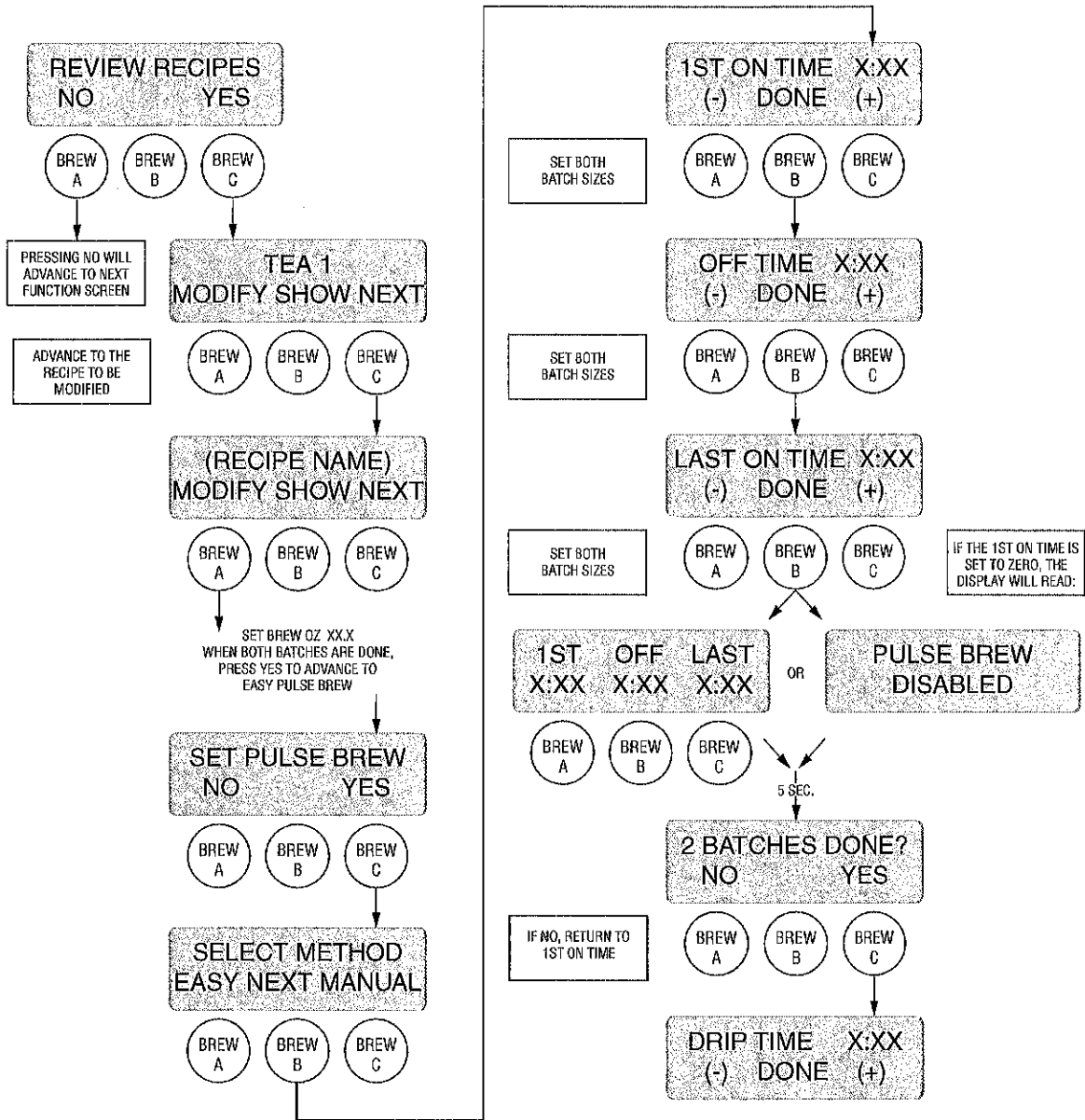

P2868

PROGRAMMING THE BREWER (cont.)

PROGRAMMING FUNCTIONS - LEVEL 2 (cont.)

COFFEE RECIPES:

DRIP TIME

This function allows the operator to adjust the **DRIP TIME** (time from end of sprayhead flow to when liquid stops dripping from the funnel). When the brew cycle is complete, the display will show **DRIPPING** and will countdown the time until the funnel empties.

Setting DRIP TIME:

Range: OFF to 5 minutes for all batch sizes.

NOTE: If the brewer is already in the **DRIP TIME** screen, skip steps 1 through 7 and proceed directly to step 8.

1. Press and hold the right hidden button until the display reads **SET LANGUAGE**. Press the right hidden button until the display reads **REVIEW RECIPES**.
2. Press **YES** to proceed. The display should now read **TEA 1**, along with **MODIFY SHOW NEXT**.
3. Press and release **NEXT** to advance to the desired coffee recipe to be modified.
4. Press and release **MODIFY**. The display should read **BREW OZ:**
5. Press and release **DONE**. The display should read **2 BATCHES DONE?**
6. Press and release **YES**. The display will read **SET PULSE BREW**.
7. Press and release **NO**. The display should now read **DRIP TIME** and a batch light should be flashing.
8. Using the **(-)** and **(+)**, set the amount of time from when the brew solenoid shuts off to when drip-out occurs for that batch size.
9. When finished, press the other batch size and repeat step 8.
10. When finished, press **DONE**. The display should read **2 BATCHES DONE?**
11. If both batch sizes are not correct, press and release **NO** to return to the **DRIP TIME** setup screen and repeat steps 8 through 10.
12. If both batch sizes are correct, press **YES**. The

display should show the name of the recipe being programmed (modified) along with **SETUP COMPLETE**. After a 5 second delay, the display will advance to the next recipe name in the brewer's memory. If no other coffee names are present, the display will read **THAT WAS THE LAST RECIPE**. To exit to the **MAIN SCREEN**, press and release the **ON/OFF** button.

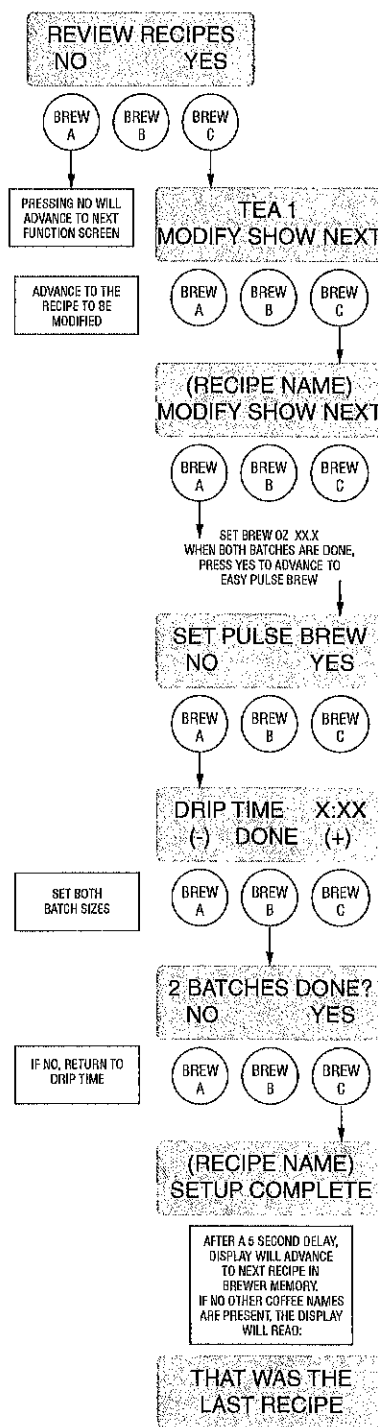

P2869

PROGRAMMING THE BREWER (cont.)

PROGRAMMING FUNCTIONS - LEVEL 2 (cont.)

MASTER TEMP

This function allows the operator to adjust the brew water temperature in the tank. This also sets the hot water faucet dispense temperature.

Procedure for setting the Master Temp

Range: 185° to 207° F (85°-97° C)

1. Press and hold the right hidden button until the display reads **SET LANGUAGE**. Press the right hidden button until the display reads **MASTER TEMP**.
2. Using (-) and (+), adjust the brew and faucet temperature.
3. When finished, press and release **DONE** to save the new setting and to advance to the next function screen, **READY DEGREE**. Press and release the ON/OFF pad to exit programming and return to the **MAIN SCREEN**.

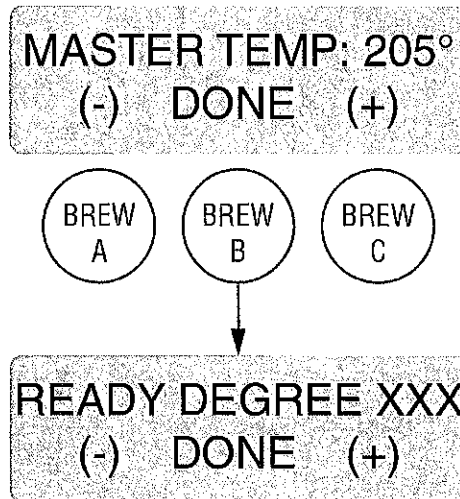

P2870

PROGRAMMING THE BREWER (cont.)

PROGRAMMING FUNCTIONS - LEVEL 2 (cont.)

READY DEGREE

This function allows the operator to set the minimum temperature allowable to start a brew cycle. The range can be from 2° to 20° F within the set temperature. The water must be at the **READY** temperature or higher for the display to indicate **READY TO BREW**. If brew lockout is enabled, the brewing process will not start below this **READY** temperature.

Procedure to set ready temperature

Range: 2° to 20° F (1° - 10° C)

1. Press and hold the right hidden button until the display reads **SET LANGUAGE**. Press the right hidden button until the display reads **READY DEGREE**.
2. Using **(-)** and **(+)**, adjust the ready temperature.
3. When finished, press and release **DONE** to save the new setting and to advance to the next function screen, **ENABLE ADS**. Press and release the ON/OFF pad to exit programming and return to the **MAIN SCREEN**.

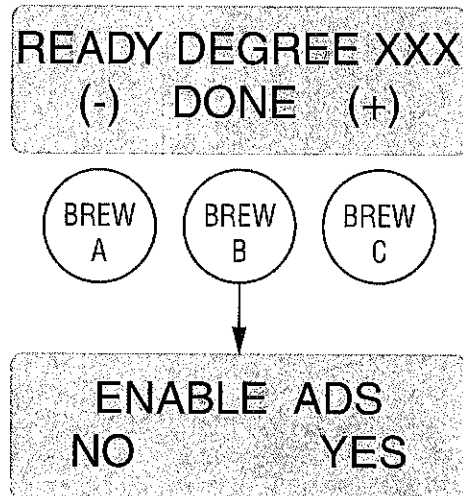

P2871

PROGRAMMING THE BREWER (cont.)

PROGRAMMING FUNCTIONS - LEVEL 2 (cont.)

ENABLE ADS

This function allows the operator to choose whether or not to display an advertising message. An ad can be saved to the brewer by either writing the ad using the programming commands, or by entering the ad into the brewer using an **AD CARD**. This message will be displayed when the brewer is not in use.

Procedure to Enable/Disable Ads:

1. Press and hold the right hidden button until the display reads **SET LANGUAGE**. Press the right hidden button until the display reads **ENABLE ADS**. The **YES** or **NO** will be flashing to indicate the current selection.
2. Press and release the **NO** button to disable this function (no ads will be displayed on the screen), or:
3. Press and release the **YES** button to enable this function (ads will be displayed on the screen).
4. When finished, press and release **DONE** to save the new setting and advance to the next function screen.
5. If **NO** was selected, the display should now read **ENABLE SANITATION**. To exit programming and return to the **MAIN SCREEN**, press and release the ON/OFF pad.
6. If **YES** was selected, the display should now read **NEW AD?**. This screen allows the operator to select between using an ad card to read in a new ad, writing an ad, or using the ad currently stored in the brewer's memory (if an ad was previously saved).

Procedure to WRITE an Ad:

NOTE: Writing and saving a new ad will erase any previously saved ad in the brewer's memory.

7. From the **NEW AD?** screen, press and release **WRITE**.
8. The display should now read **2 LINES 16 CHARS AVAILABLE**, and then **SCROL THRU ALPHA, NEXT -> NEXT LETTER**, and then **WRITE TOP LINE?**. The ad can be up to 32 characters long, 16 per line. The ad will be written in two steps, first the top line, then the bottom line.
9. To write the top line of a new ad, press and release **YES**. To skip the top line and only write a bottom

line, press and release **NO** and proceed to step 13. To exit programming and return to the **MAIN SCREEN**, press and release the ON/OFF pad.

10. The display will now read **A** with a flashing cursor below it. Press and hold the **SCROLL** button to scroll through the alphabet and available characters. When the desired character is shown on the display, press and release **NEXT** to move to the next character in the top line.
11. Repeat step 10 until the top line is complete.
12. Press and release **DONE**. The display should now read **WRITE BTM LINE?**.
13. To write the bottom line of the new ad, press and release **YES**.
14. To skip the bottom line, press and release **NO**.
 - a. If neither a top nor bottom line was written, the display should now read **ENABL SANITATION**.
 - b. If only a top line was written, the ad will be displayed followed by **SAVE?** Proceed to step 18.
15. The display will now read **A** with a flashing cursor below it. Press and hold the **SCROLL** button to scroll through the alphabet and available characters. When the desired character is shown on the display, press and release **NEXT** to move to the next character in the bottom line.
16. Repeat step 15 until the bottom line is complete.
17. Press and release **DONE**. The display will now show the written ad, and then **SAVE?**
18. To cancel saving the ad, press and release **NO**. The display should now read **ADVERTISEMENT NOT SAVED!** and then will return to the **NEW AD** screen. To exit programming and return to the **MAIN SCREEN**, press and release the ON/OFF pad.
19. To correct or edit the ad, press and release **EDIT**. The display should now read **WRITE TOP LINE?** Repeat steps 10 through 17.
20. To save the ad as it is shown, press and release **YES**. The display should now read **ADVERTISEMENT SETUP COMPLETE**, and then **ENABL SANITATION**. To exit programming and return to the **MAIN SCREEN**, press and release the ON/OFF pad.

PROGRAMMING THE BREWER (cont.)

PROGRAMMING FUNCTIONS - LEVEL 2 (cont.)

ENABLE ADS (Continued)

Procedure to READ in a New Ad:

NOTE: Saving a new ad will erase any previously saved ad in the brewer's memory.

1. From the **NEW AD?** screen, press and release **CARD**.
2. The display will show **INSERT AD CARD**. Place the AD CARD vertically so that the top end of the "chip" is beneath the sensing coil (located on the middle of the underneath side of the front display panel).

3. After a short pause, the display will read **CARD CONTAINS AD**. To view the ad, press and release **SHOW**. To save the ad to the brewer's memory, press and release **SAVE**. To cancel, Press **QUIT**.
4. After the ad is saved, the display will read **AD SETUP COMPLETE**, and then will advance to to next programming function, **ENABLE SANITATION**.

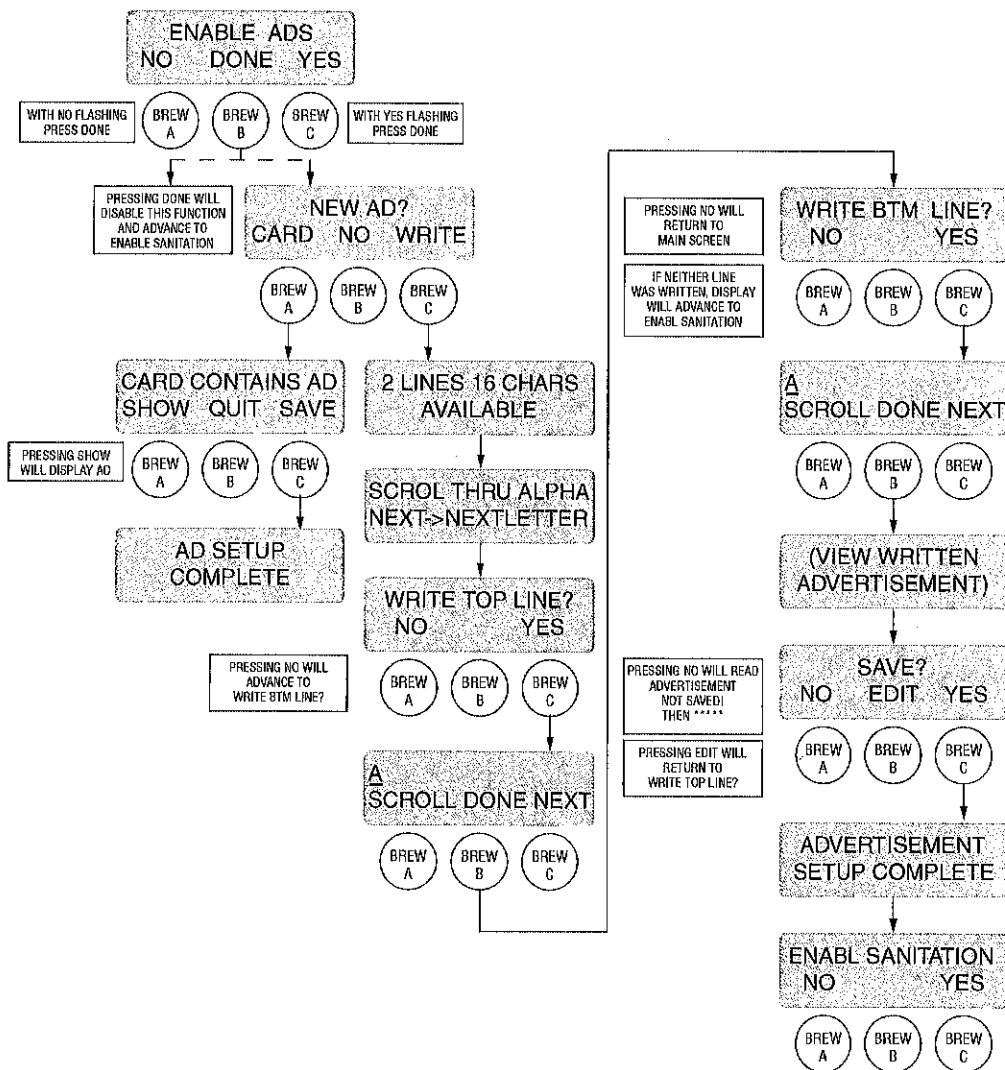

P2872

PROGRAMMING THE BREWER (cont.)

PROGRAMMING FUNCTIONS - LEVEL 2 (cont.)

ENABL SANITATION

This function allows the operator to enable the sanitation function and set the time before a cleaning alert will be displayed.

Procedure for enabling sanitation:

Range: 0.0 to 72.0 hrs.

1. Press and hold the right hidden button until the display reads **SET LANGUAGE**. Press the right hidden button until the display reads **ENABL SANITATION**. The **YES** or **NO** will be flashing to indicate the current selection.
2. Press and release the **NO** button to disable this function (no sanitation alert will be displayed on the screen), or:
3. Press and release the **YES** button to enable this function (a sanitation alert will be displayed on the screen).
4. When finished, press and release **DONE** to save the new setting and advance to the next function screen.
5. If **NO** was selected, the display should now read **ENABLE ENERGYSAVR**. To exit programming and return to the **MAIN SCREEN**, press and release the ON/OFF pad.
6. If **YES** was selected, the display should now read **X.X HRS -> CLEAN**. This screen allows the operator to set the amount of time from when a brew is completed until a sanitize alert will be displayed. Use (-) and (+) to adjust the set time. When finished, press and release **DONE**.

NOTE: The timer will not begin until after a brew cycle has been completed.

7. The display should now read **X.X HRS UNTIL NEXT CLEAN**, and then advance to the next programming function, **ENABLE ENERGYSAVR**.
8. Once the set time has expired, the display will read **PLEASE SANITIZE**, and then **PRESS FULL FOR 3 SEC TO CANCEL**.
9. Clean and sanitize the machine.
10. When finished, press and hold the FULL batch button to reset the Sanitation timer. The display should now read **SANITATION COMPLETE** and then will return to the **MAIN SCREEN**.

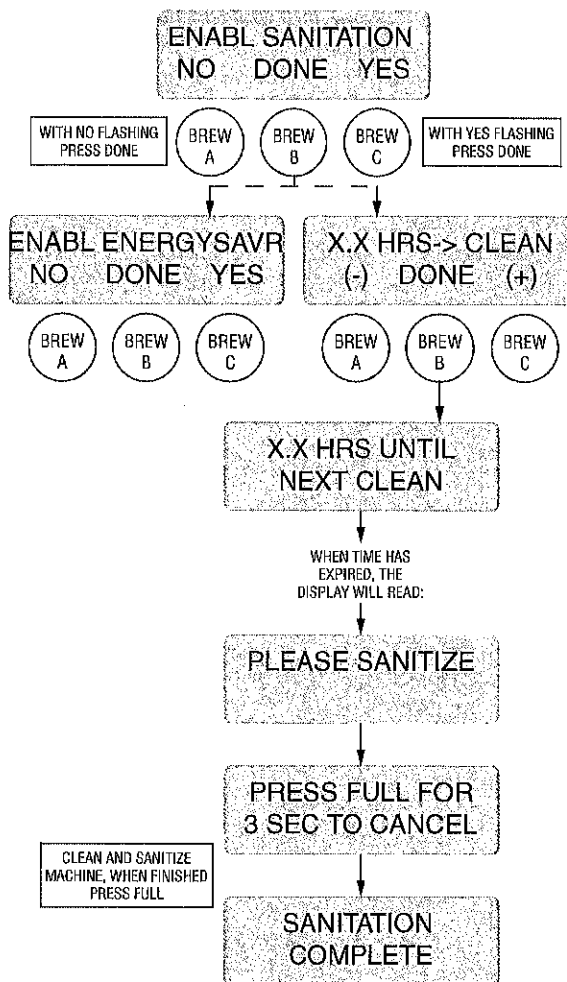

P2873

PROGRAMMING THE BREWER (cont.)

PROGRAMMING FUNCTIONS - LEVEL 2 (cont.)

ENABLE ENERGYSAVR

This function allows the operator to enable the mode function and set the idle time. Once the set idle time has expired, the operator can choose to have the heaters either turn off, or reduce the tank holding temp to 140° F (60° C).

Procedure to enable energy savings mode:

Range: 0.5 to 24.0 hrs. If enabled, default setting is 140°F tank temperature after 4.0 hrs. idle time.

1. Press and hold the right hidden button until the display reads **SET LANGUAGE**. Press the right hidden button until the display reads **ENABLE ENERGYSAVR**. The **YES** or **NO** will be flashing to indicate the current selection.
2. Press and release the **NO** button to disable this function, or:
3. Press and release the **YES** button to enable this function (the heaters will either turn off or the tank will hold at 140° F).
4. When finished, press and release **DONE** to save the new setting and advance to the next function screen.
5. If **NO** was selected, the display should now read **EnableFreshTimer**. To exit programming and return to the **MAIN SCREEN**, press and release the ON/OFF pad.
6. If **YES** was selected, the display should now read **X.X HRS -> IDLE**. This screen allows the operator to set the amount of time the brewer is not in use before nap mode engages. Using **(-)** and **(+)**, adjust the idle time. When finished, press and release **DONE**.
7. The display should now read **AFTER IDLE TIME?** Once the set idle time has expired, the heaters can either be shut off or held at a lower temperature of 140° F.
8. To have the machine shut off after the set idle time, press and release **OFF** and then **DONE** to save the settings. The display should read **MACHINE OFF AFTER X.X HRS**, and then **EnableFreshTimer**.
9. To have the heaters hold at the lower 140° F temperature, press and release **140° F** and then **DONE** to save the settings. The display should read **MACHINE AT 140° F AFTER X.X HRS**, and then **EnableFreshTimer**.

10. Once the idle time has expired, the display will read either **ENERGY SAVER...NO TEMPERATURE** or **ENERGY SAVER...REDUCED TEMPERATURE**, depending on the settings. This screen will alternate with **PRESS ANY SWITCH TO RE-HEAT**.

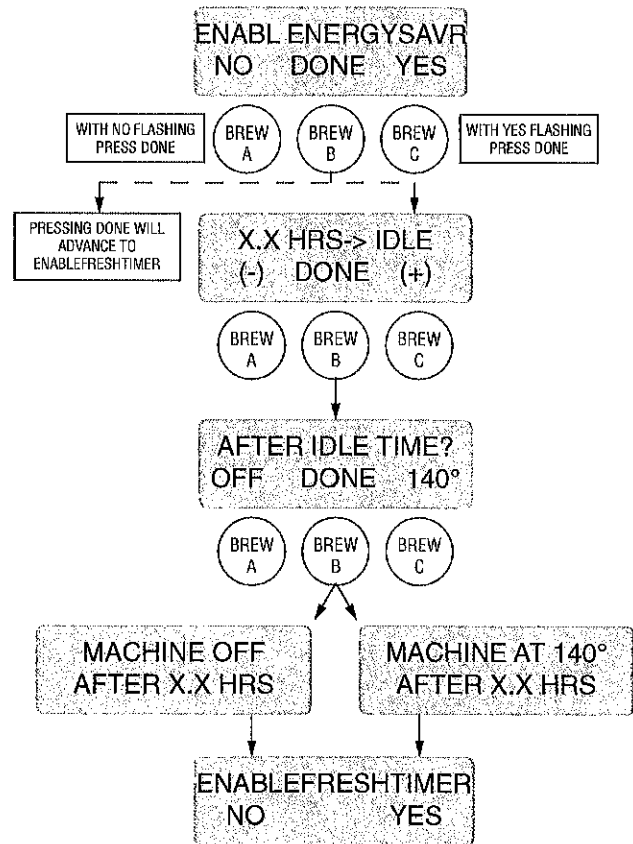

P2874

PROGRAMMING THE BREWER (cont.)

PROGRAMMING FUNCTIONS - LEVEL 2 (cont.)

ENABLE FRESH TIMER

This function allows the operator to enable the Freshness Alert and set the expiration time. The expiration time is the amount of time the product is allowed to sit in the server/dispenser before a fresh batch is brewed.

Procedure for enabling/setting the Freshness Timer:

Range: Iced Tea 0.5 to 10.0 hrs. Hot Tea 0.5 to 8.0 hrs. Iced Coffee 0.5 to 8.0 hrs. Coffee 0.5 to 4.0 hrs. If enabled, default setting is 8.0 hrs. for Iced Tea, 2.0 hrs for Hot Tea, 4.0 hrs for Iced Coffee, and 2.0 hrs. for Coffee.

1. Press and hold the right hidden button until the display reads **SET LANGUAGE**. Press the right hidden button until the display reads **ENABLEFRESH-TIMER**.
2. Press and release the **NO** button to disable this function, or:
3. Press and release the **YES** button to enable this function (the unit will display a message once the set time has expired).
4. When finished, press and release **DONE** to save the new setting and advance to the next function screen.
5. If **NO** was selected, the display should now read **REFILL**. To exit programming and return to the **MAIN SCREEN**, press and release the ON/OFF pad.
6. If **YES** was selected, the display should now read **TEA**. This screen allows the operator to set the amount of time from the end of brewing a batch of tea until a Freshness Alert message will be displayed. Using **(-)** and **(+)**, adjust the freshness time for tea. When finished, press and release **DONE**.
7. The display should now read **HOT TEA**. Using **(-)** and **(+)**, adjust the freshness time for hot tea. When finished, press and release **DONE**.
8. The display should now read **ICED COFFEE**. Using **(-)** and **(+)**, adjust the freshness time for iced coffee. When finished, press and release **DONE**.
9. The display should now read **COFFEE**. Using **(-)** and **(+)**, adjust the freshness time for coffee. When finished, press and release **DONE**.
10. This display should now read **REFILL**. To exit programming and return to the **MAIN SCREEN**, press and release the ON/OFF pad.

11. Once the set time has expired, the display will read **FRESHNESS ALERT BREW X**, and then **FRESHNESS ALERT BREW FRESH BATCH** alternating with the **MAIN SCREEN**.
12. Empty the server/dispenser the previous batch was brewed into and replace under the funnel.
13. Brew a new batch
14. The freshness timer will reset. The display should now return to the **MAIN SCREEN**.

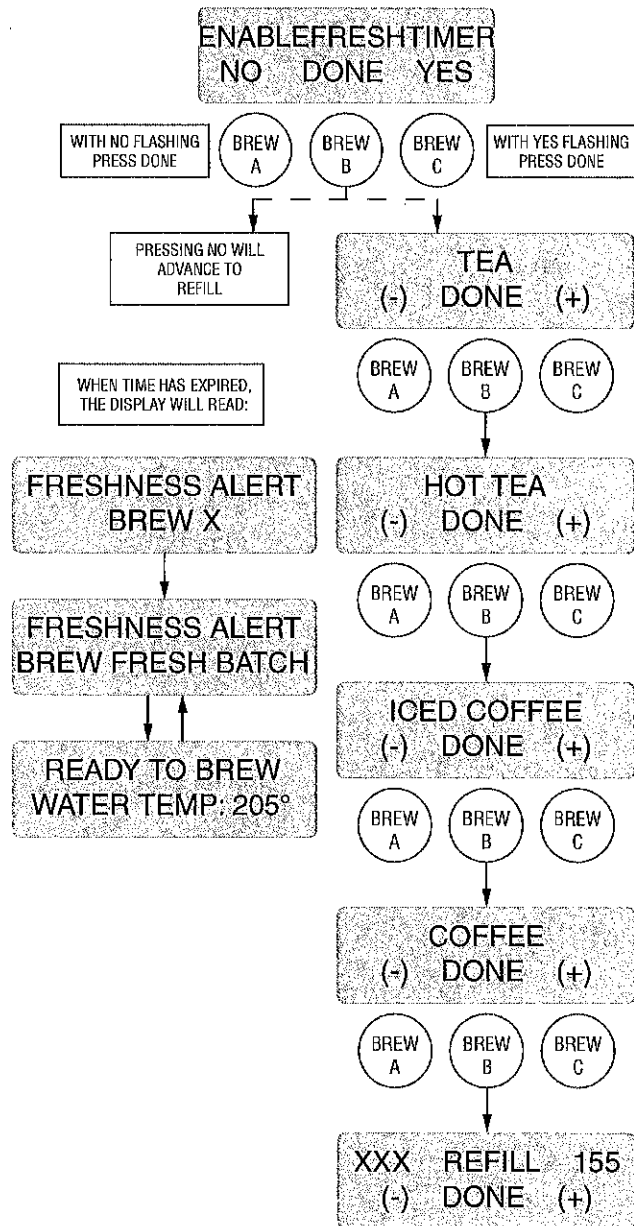

PROGRAMMING THE BREWER (cont.)

PROGRAMMING FUNCTIONS - LEVEL 2 (cont.)

REFILL

Range: 0 to 155

This function allows the operator to adjust the sensitivity of the refill circuit. This is mainly a troubleshooting feature. Water in different geographical locations can have different conductivities. By adjusting the sensitivity of the refill circuit, this will allow the brewer to operate under various water conditions.

Procedure to set the sensitivity threshold of the refill circuit:

NOTE: Make sure the water in the tank is touching the refill probe.

1. Press and hold the right hidden button until the display reads **SET LANGUAGE**. Press the right hidden button until the display reads **REFILL** and shows a number on both sides of the word.
2. To adjust the threshold setting, press **(-)** to decrease or **(+)** to increase the setting.

NOTE: Always make sure that the number on the right is larger than the number on the left when water is in contact with the refill probe in the tank.

3. When finished, press and release **DONE**. This saves the new setting and advances to the next function screen **SPRAY OZ/M**. To exit programming and return to the **MAIN SCREEN**, press and release the ON/OFF pad.

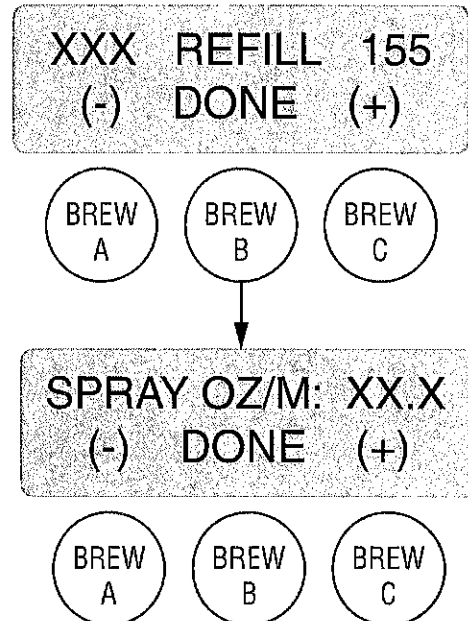

P2876

PROGRAMMING THE BREWER (cont.)

PROGRAMMING FUNCTIONS - LEVEL 2 (cont.)

SPRAY OZ/M

This function allows the operator to view or to enter the actual flow rate coming out of the sprayhead. This is **NOT** used to change the actual flow rate, but to tell the internal controller how fast the water is flowing.

Procedure to adjust the sprayhead flow rate setting:

1. Press and hold the right hidden button until the display reads **SET LANGUAGE**. Press the right hidden button until the display reads **SPRAY OZ/M**. The number represents what the brewer thinks is the flow rate out of the sprayhead.
2. If the actual flow rate of the sprayhead is known but is different than the number on the display, use the (-) and (+) to enter the correct flow rate.
3. When finished, press and release **DONE**. This saves the new setting and advances to the next function screen, **DILUTE OZ/M**. To exit programming and return to the **MAIN SCREEN**, press and release the ON/OFF pad.

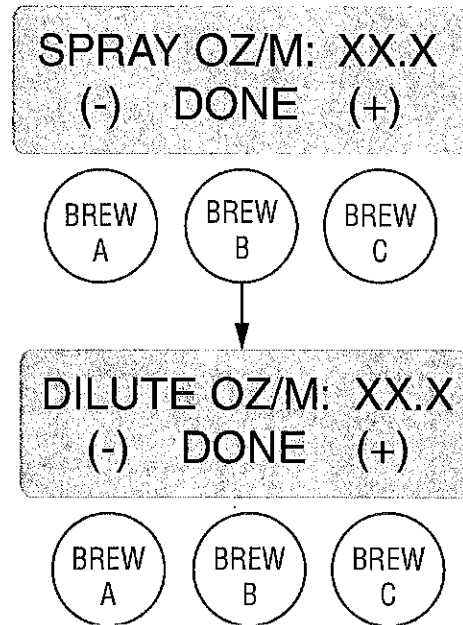

P2877

PROGRAMMING THE BREWER (cont.)

PROGRAMMING FUNCTIONS - LEVEL 2 (cont.)

DILUTE OZ/M

This function allows the operator to view or to enter the actual flow rate coming out of the dilution nozzle. This is **NOT** used to change the actual flow rate, but to tell the internal controller how fast the water is flowing.

Procedure to adjust the dilution flow rate setting:

1. Press and hold the right hidden button until the display reads **SET LANGUAGE**. Press the right hidden button until the display reads **DILUTE OZ/M**. The number represents what the brewer thinks is the flow rate out of the dilution nozzle.
2. If the actual flow rate of the nozzle is known but is different than the number on the display, use the **(-)** and **(+)** to enter the correct flow rate.
3. When finished, press and release **DONE**. This saves the new setting and advances to the next function screen, **CALIBRATE FLOW**. To exit programming and return to the **MAIN SCREEN**, press and release the ON/OFF pad.

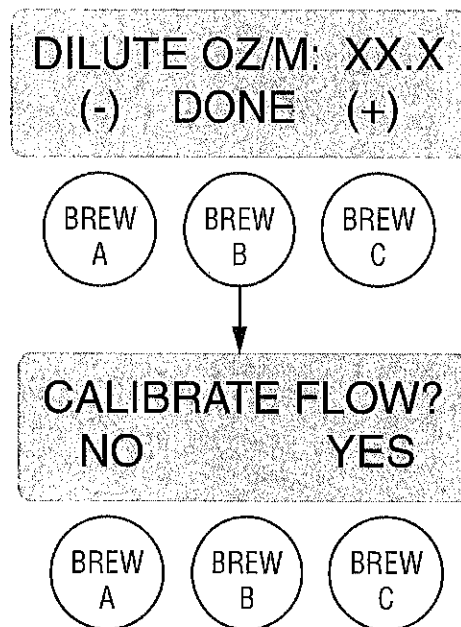

F2878

PROGRAMMING THE BREWER (cont.)

PROGRAMMING FUNCTIONS - LEVEL 2 (cont.)

CALIBRATE FLOW

This function allows the operator to enter the actual flow rate of the sprayhead and the dilution by dispensing both separately for one minute. The volumes are then entered into the brewer.

Procedure to calibrate the sprayhead flow rate:

1. Place a container, accurately graduated and with a minimum capacity of 60 ounces (1.77 liters), beneath the funnel.
2. Press and hold the right hidden button until the display reads **SET LANGUAGE**. Press the right hidden button until the display reads **CALIBRATE FLOW**.
3. Press and release **YES** to advance to the **SPRAY HEAD CAL** function screen. (Pressing **NO** in the **CALIBRATE FLOW** screen will advance to the next function screen, **BREW COUNTERS**).
4. Press and release the **YES** pad. The display should read **CONTAINER READY?** If the container is under the funnel, press **YES**.
5. The display should read **CALIBRATE SPRAY**. Press and release **START** to begin the sprayhead flow for calibration. The display should read **CALIBRATE SPRAY... 60 SEC TO FINISH**. The 60-second timer on the display will count down to zero. When the counter reaches zero, the display will change to **SPRAY HD OZ/M**, along with a number.
6. Measure the amount of water in the container and use the **(-)** and **(+)** pads to adjust the amount of the display to match the amount in the container. Then press **DONE**.
7. The display should now read **NEW SPRAY FLOW**, along with the correct flow rate of the sprayhead. After about 5 seconds, the display will return to the **CALIBRATE FLOW** screen.
8. To exit the **CALIBRATE FLOW** function and advance to the next function screen, press and release **NO**. To exit programming, press and release the ON/OFF button to return to the **MAIN SCREEN**.



PROGRAMMING THE BREWER (cont.)

PROGRAMMING FUNCTIONS - LEVEL 2 (cont.)

CALIBRATE FLOW (Continued)

Procedure to calibrate the dilution flow rate:

1. Place a container, accurately graduated and with a minimum capacity of 130 ounces, beneath the funnel.

NOTE: If the display is already on the **DILUTION CAL** screen, skip steps 2 & 3 and proceed directly to step 4.

2. Press and hold the right hidden button until the display reads **SET LANGUAGE**. Press the right hidden button until the display reads **CALIBRATE FLOW**.
3. Press and release **YES** to advance to the **SPRAY HEAD CAL** function screen. Press and release **NO** to advance to **DILUTION CAL**.
4. Press and release the **YES** pad. The display should read **CONTAINER READY?** If the container is under the funnel, press **YES**.
5. The display should read **CALIBRATE DILUTE**. Press and release **START** to begin the dilution flow for calibration. The display should read **CALIBRATE DILUTE...60 SEC TO FINISH**. The 60-second timer on the display will count down to zero. When the counter reaches zero, the display will change to **DILUTE OZ/M**, along with a number.
6. Measure the amount of water in the container and using the **(-)** and **(+)** pads, adjust the amount of the display to match the amount in the container. Then press **DONE**.
7. The display should now read **NEW DILUTE FLOW**, along with the correct flow rate of the sprayhead. After about 5 seconds, the display will return to the **CALIBRATE FLOW** screen, **BREW COUNTERS**. To exit programming, press and release the ON/OFF button to return to the **MAIN SCREEN**.

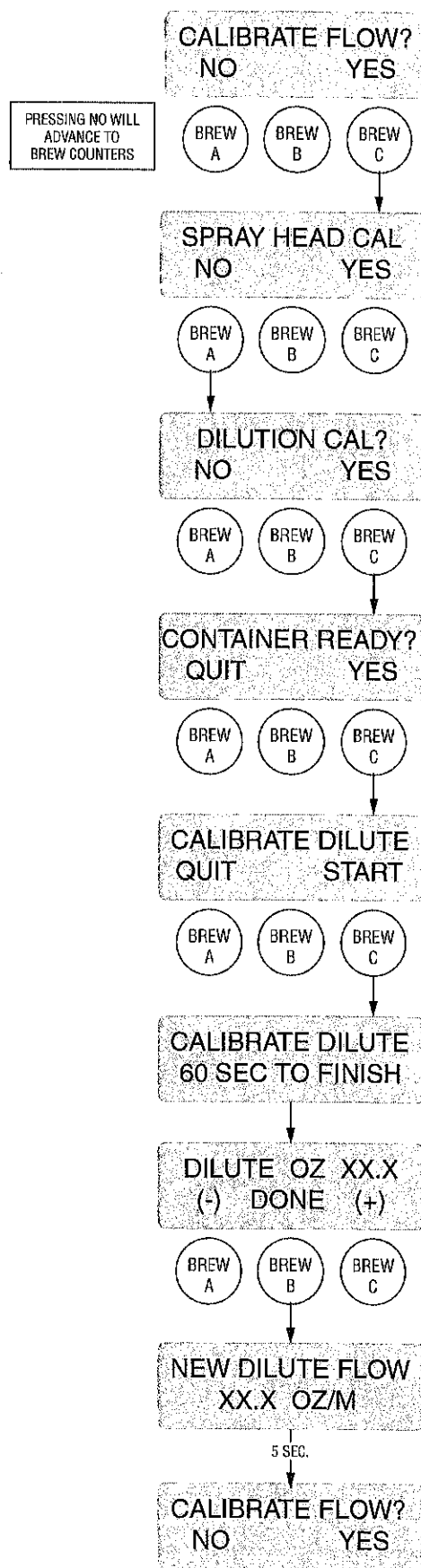

PROGRAMMING THE BREWER (cont.)

PROGRAMMING FUNCTIONS - LEVEL 2 (cont.)

BREW COUNTERS

This function allows the operator to track the total number of brew cycles completed, as well as the number of batches brewed using each of the brew buttons. There are three resettable counters, and one life counter that is not resettable.

Procedure to view/reset the brew counters:

1. Press and hold the right hidden button until the display reads **SET LANGUAGE**. Press the right hidden button until the display reads **BREW COUNTERS**.
2. Pressing **NO** will advance to the next programming function, **RECIPE TEMP**. Press **YES** to view the first brew counter (**TOTAL LIFE BREWS**). This number represents the total number of brew cycles this brewer has completed. This counter is non-resettable. Press **NEXT** to advance to the next brew counter, **BREW A**.
3. This counter represents the number of brews for Brew A. To reset the counter to zero, press and release **RESET**. Press and release **NEXT** to advance to the next counter.
4. Repeat step 3 for the remaining two counters, **BREW B** and **BREW C**.
5. When finished, press **NEXT** to advance to the next programming function, **SET RECIPE TEMPS**. To exit programming, press and release the ON/OFF button to return to the **MAIN SCREEN**.

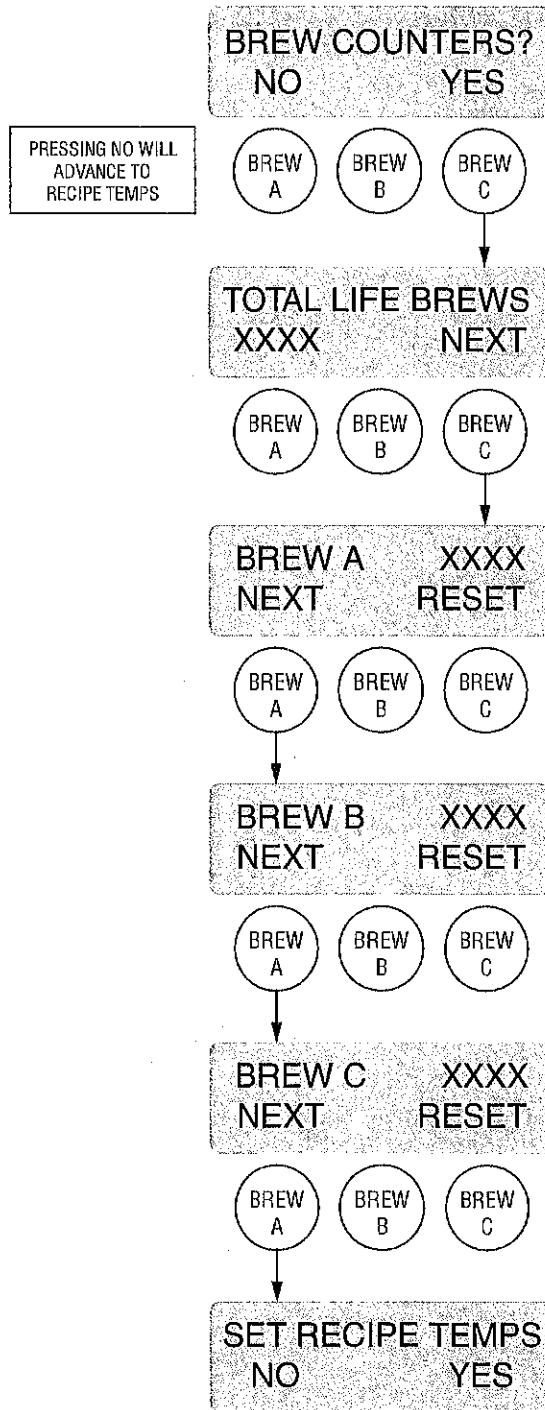

P2881

PROGRAMMING THE BREWER (cont.)

PROGRAMMING FUNCTIONS - LEVEL 2 (cont.)

SET RECIPE TEMPS

This function allows the operator to set separate temperatures for each selected recipe.

NOTE: Setting recipe temps will override the **MASTER TEMP**. The tank will hold at the lowest temperature between the three selected recipes stored in the brew buttons. For instance, let's say Brew A's recipe temperature is set at 205°, Brew B's recipe temperature is set at 205°, and Brew C's recipe temperature is set at 200°. The tank will hold at 200°. If Brew A or Brew B is pressed, the tank will heat to the 205° temperature. The brew button must be pressed again in order for a brew to start. After the completion of that brew, the tank will return to the 200° holding temperature. It may take awhile for the tank to return to the lower temperature.

1. Press and hold the right hidden button until the display reads **SET LANGUAGE**. Press the right hidden button until the display reads **SET RECIPE TEMPS**.
2. To set different temperatures for different recipes, press and release **YES**. Pressing **NO** will advance to the next programming function, **SERVICE TOOLS**.
3. The display should read **WILL OVERRIDE THE MASTER TEMP**, and then **OVERRIDE?** To retain the **MASTER TEMP** setting, press and release **NO**. To set separate recipe temperatures, press and release **YES**.
4. The display should read **TEA 1**. Using **(-)** and **(+)**, adjust the temperature for **TEA 1**. When finished, press and release **DONE**.
5. The screen should now read **TEA 2**. Use **(-)** and **(+)** to adjust the temperature for **TEA 2**. When finished, press and release **DONE**.
6. Repeat for all standard and stored recipes.
7. After the last temperature has been entered, press **DONE**. The screen should now read **TANK WILL HOLD AT LOWEST TEMP**, and then advance to the **ENTER ASSET #** screen. To exit programming, press and release the ON/OFF button to return to the **MAIN SCREEN**.

NOTE: To return to using the **MASTER TEMP** setting after **RECIPE TEMPS** have been used, press and hold

the right hidden switch until the display reads **SET LANGUAGE**. Press and release the right hidden switch until the display reads **SET RECIPE TEMPS**. Press and release **YES**. The display will read **WILL OVERRIDE THE**

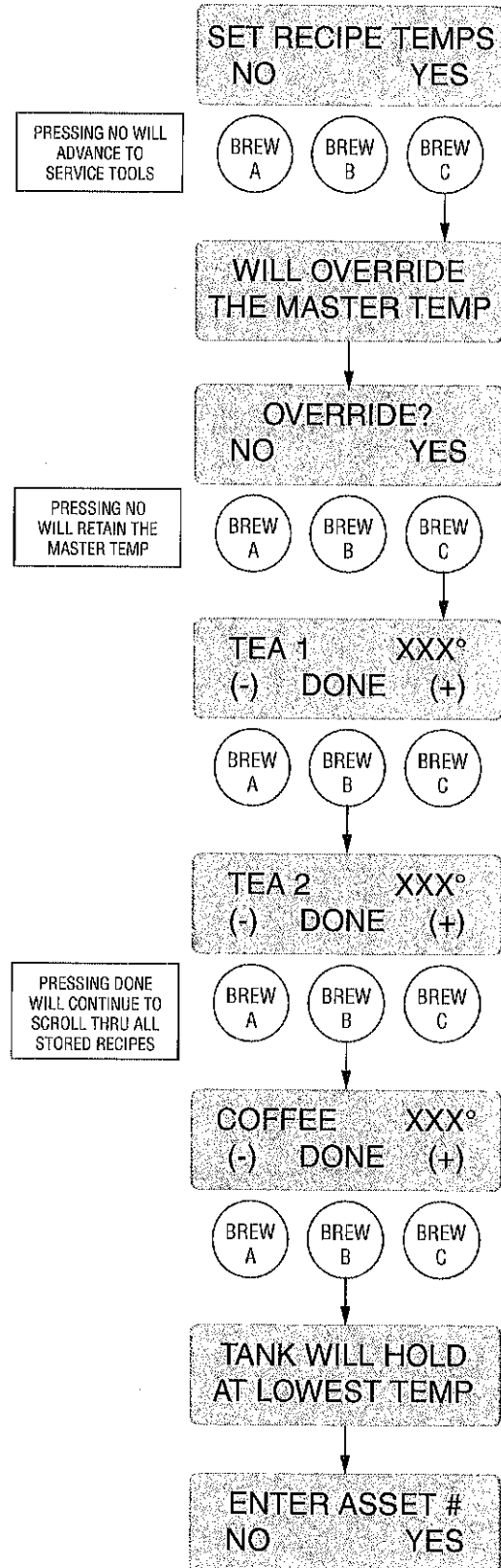

PROGRAMMING THE BREWER (cont.)

PROGRAMMING FUNCTIONS - LEVEL 2 (cont.)

ASSET NUMBER

This function allows the operator to enter in the machine's asset number. This can be useful for tracking the usage or service of an individual machine within a group.

Procedure to enter the asset number:

1. Press and hold the right hidden button until the display reads **SET LANGUAGE**. Press the right hidden button until the display reads:
ENTER ASSET #?
2. Press and release **YES**. The display will now read **AN XXXXXX**.
(-) DONE (+)
3. Using **(-)** and **(+)**, set the asset number of the machine.
4. When finished, press and release **DONE**. The display will now read **SERVICE #**.

NOTE: See page 9 for steps on how to view the Asset Number.

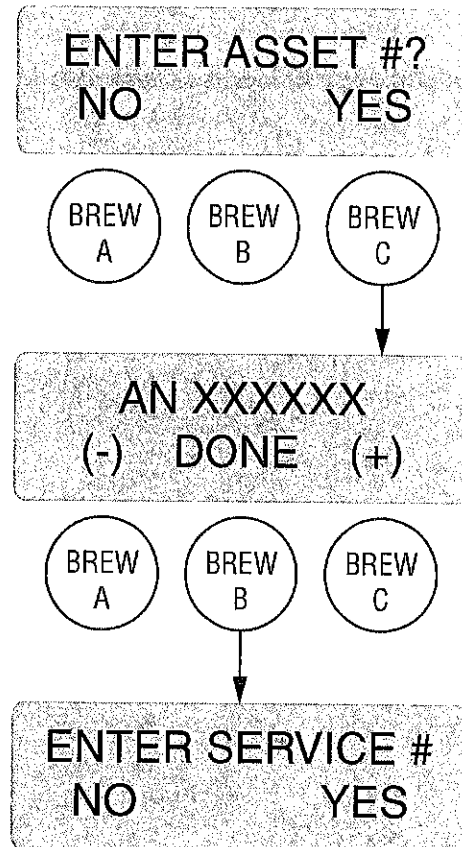

P2951

PROGRAMMING THE BREWER (cont.)

PROGRAMMING FUNCTIONS - LEVEL 2 (cont.)

SERVICE NUMBER

This function allows the operator to enter in the telephone number to call if service is needed. The service number will be displayed anytime there is a fault message displayed. (See Troubleshooting on page 63)

Procedure to enter the service number:

1. Press and hold the right hidden button until the display reads **SET LANGUAGE**. Press the right hidden button until the display reads:
ENTER SERVICE #?
2. Press and release **YES**. The display will now read **SCROL THRU #'S NEXT ->NEXT NUMBER**, followed by **000-000-0000**. Up to 16 characters are available.
3. Press the **SCROL** button to scroll through the numbers. When the desired number is shown, press and release **NEXT** to move to the next digit in the phone number.
4. Repeat Step 3 until the entire number is entered.
5. Press and release **DONE**. The display will now read **SERVICE TOOLS?**

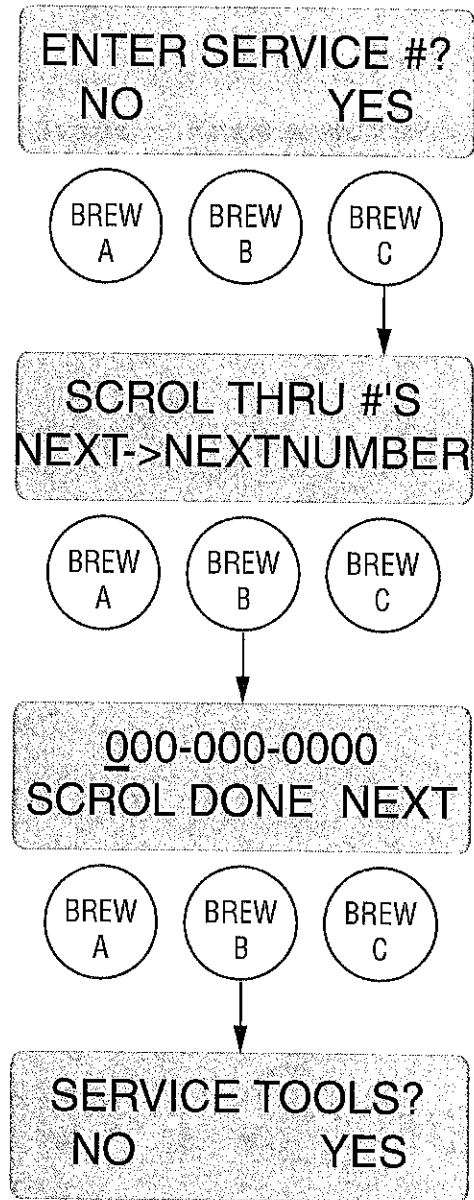

P3049

PROGRAMMING THE BREWER (cont.)

PROGRAMMING FUNCTIONS - LEVEL 2 (cont.)

SERVICE TOOLS

This function allows the testing of individual components and the ability to check switches for proper function. This function also tests the funnel sensor coil's frequency (diagnostic tool for troubleshooting purposes only).

Procedure to test components and outputs:

The following components can be individually tested:

Brew Valve
Dilution Valve
Refill Valve
Tank Heater Relay
Tank Heater Triac

1. Place a funnel into the rails of the brewer.
 2. Place a server beneath the funnel.
 3. Press and hold the right hidden button until the display reads **SET LANGUAGE**. Press the right hidden button until the display reads **SERVICE TOOLS**.
 4. Press and release **YES**. The display should now read **TEST OUTPUTS?** Press and release **YES** to test individual components and outputs. Pressing **NO** will advance to the next programming function, **TEST SWITCHES**.
 5. The display should now read **BREW VALVE**. To test the brew valve, press **ON**. If the brew valve is functional, water should run from the funnel.
 6. Press **OFF** to end the flow of water.
 7. Press **NEXT** to advance to the next component to be tested.
- NOTE:** To bypass testing any component, press **NEXT** to advance to the next component without testing the previous one.
8. The display should now read **DILUTION**. To test the dilution valve, press **ON**. If the dilution valve is functional, water should run from the nozzle.
 9. Press **OFF** to end the flow of water.
 10. Press **NEXT** to advance to the next component to be tested, **REFILL VALVE**.
 11. To test the **REFILL VALVE**, press **ON**. If the refill valve is functional, the sound of the valve operating will be heard.
 12. Press **OFF** to end testing of the refill valve.
 13. Press **NEXT** to advance to the next component to be tested, **TANK HEATR RELAY**.
 14. To test the tank heater relay, connect a voltmeter across each of the tank heaters to check for voltage.
 15. Press **ON**. The correct voltage should be present at the heater terminals.
 16. Press **OFF** to end testing of the tank heater relay.
- NOTE:** The tank heater will automatically turn off if left on too long.
17. Press **NEXT** to advance to the next component to be tested, **TANK HEATR TRIAC**.
 18. To test the tank heater triac, connect a voltmeter across each of the tank heaters to check for voltage.
 19. Press **ON**. The correct voltage should be present at the heater terminals.
 20. Press **OFF** to end testing of the tank heater triac.
 21. Press **NEXT** to **TEST OUTPUTS?**. To exit programming, press and release the ON/OFF button to return to the **MAIN SCREEN**.

PROGRAMMING THE BREWER (cont.)

PROGRAMMING FUNCTIONS - LEVEL 2 (cont.)

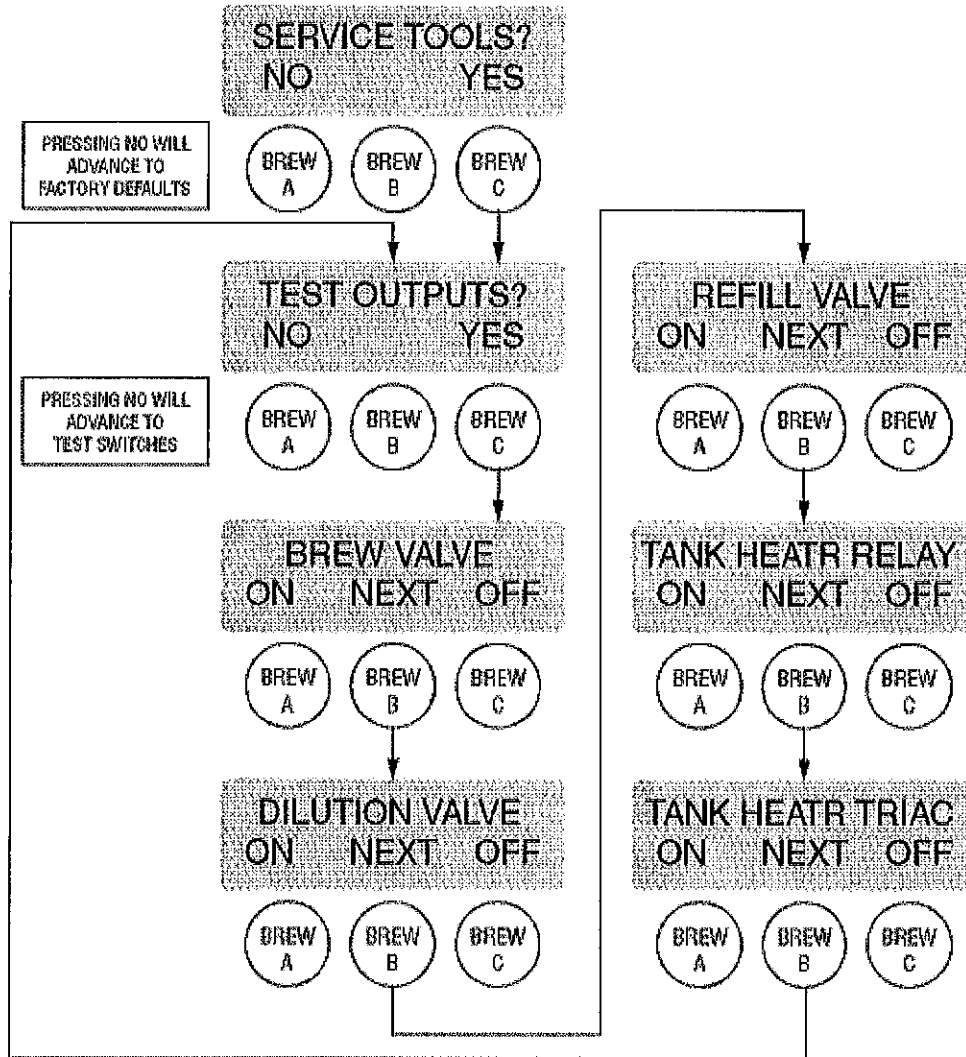

P2883

PROGRAMMING THE BREWER (cont.)

PROGRAMMING FUNCTIONS - LEVEL 2 (cont.)

Procedure to test switches:

The following switches can be individually tested:

- Half Batch
- Full Batch
- Left Hidden
- Brew A
- Brew B
- Brew C
- On/Off

1. Press and hold the right hidden button until the display reads **SET LANGUAGE**. Press the right hidden button until the display reads **SERVICE TOOLS**.
2. Press and release **YES**. The display should now read **TEST OUTPUTS?** Press and release **NO** to advance to **TEST SWITCHES**.
3. Press and release **YES**. The display should now read **RIGHT HIDDEN TO EXIT**, and then **NOTHING PRESSED**.
4. From this screen, press any of the switches on the front of the brewer. While the switch is pressed, the display shows the name of that switch. If the name does not appear, or if it remains after the switch has been released, the switch is defective. Each switch can be tested in this manner.

After all switches have been tested, press and release the right hidden button to return to the **TEST SWITCHES** screen. To exit programming, press and release the ON/OFF button to return to the **MAIN SCREEN**.

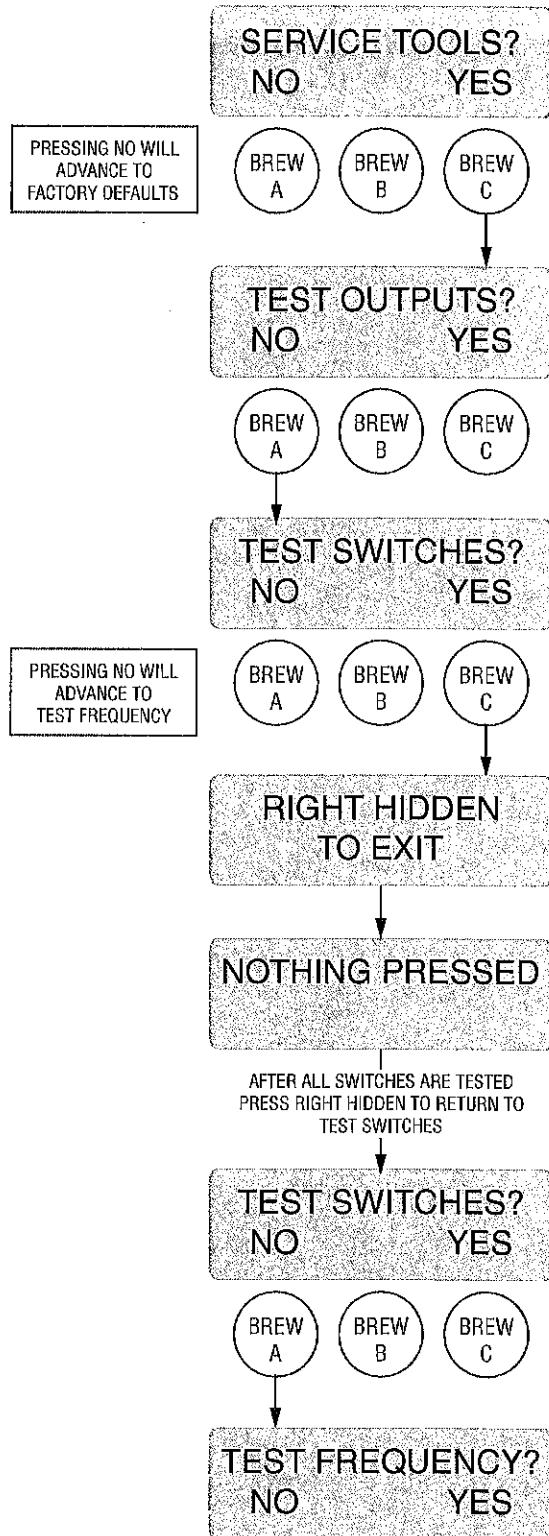

P2884

PROGRAMMING THE BREWER (cont.)

PROGRAMMING FUNCTIONS - LEVEL 2 (cont.)

Procedure to test coil frequency:

1. Press and hold the right hidden button until the display reads **SET LANGUAGE**. Press the right hidden button until the display reads **SERVICE TOOLS**.
2. Press and release **YES**. The display should now read **TEST OUTPUTS?** Press and release **NO** to advance to **TEST SWITCHES**.
3. Press and release **NO** to advance to **TEST FREQUENCY**.
4. The display should now show the frequency of the sensor coil circuit. This is for diagnostic service use when troubleshooting this circuit.
5. After the coil has been tested, press and release the **ON/OFF** button to return to the **MAIN SCREEN**.

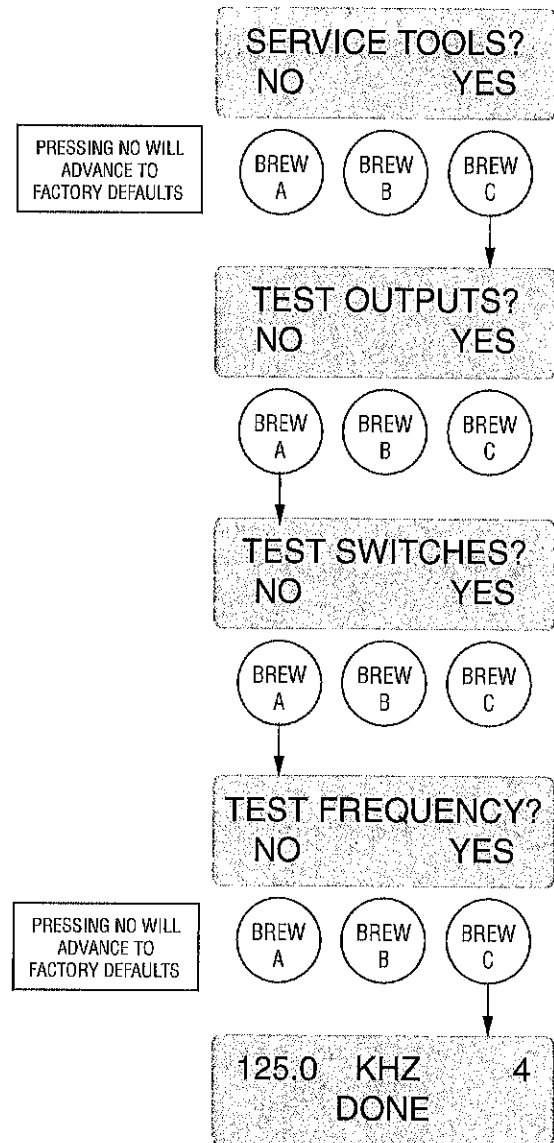

P2885

PROGRAMMING THE BREWER (cont.)

PROGRAMMING FUNCTIONS - LEVEL 2 (cont.)

FACTORY DEFAULTS

This function allows the operator to erase **ALL** of the previously entered recipes and ad messages. Factory-set default values will replace **ALL** previous settings.

Procedure to set factory defaults:

1. Press and hold the right hidden button until the display reads **SET LANGUAGE**. Press the right hidden button until the display reads **FACTORY DEFAULTS**.
2. Pressing **NO** will return to the **MAIN SCREEN**. Press **YES** to restore defaults. The display will read **WILL REPLACE ALL BREW SETTINGS** followed with **ARE YOU SURE?**
3. Pressing **NO** in this confirmation screen will revert to the **MAIN SCREEN** without resetting the brewing setups to the defaults. Press **YES** to load the defaults. After factory defaults have been restored, the display will return to the **MAIN SCREEN**. The factory default valves will have replaced **ALL** previously entered values. It will **NOT** reset the life brew counter. If factory defaults are restored, it will be necessary to recalibrate the flow rates. Refer to pages 50-51.

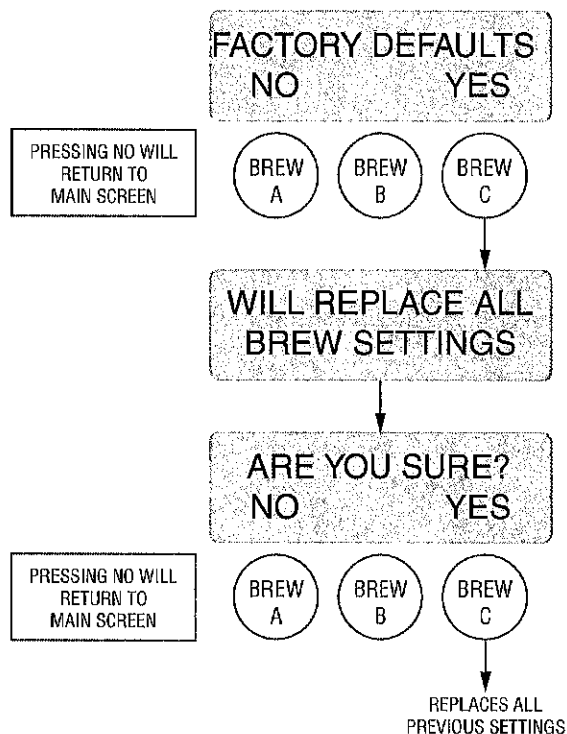

P2886

PROGRAMMING THE BREWER (cont.)

PROGRAMMING FUNCTIONS - LEVEL 2 (cont.)

FACTORY DEFAULT VALUES

Brew Lockout - Disabled

Language - English

Units - English

SWITCH RECIPE

Brew A – TEA 1

Brew B – HOT TEA

Brew C – NO-NAME COFFEE

TEA 1 RECIPE:

BREW VOLUMES

Half Batch – 38 OZ

Full Batch – 76 OZ

DILUTION VOLUMES

Half Batch – 160 OZ

Full Batch – 320 OZ

DILUTION DELAY

Half Batch – 0:00

Full Batch – 0:00

PULSE BREW TIMES

Half Batch – Manual :30/:15/:15

Full Batch – Manual :30/:15/:15

DRIP OUT TIMES

Half Batch – 0:55

Full Batch – 1:20

TEA 2 RECIPE:

BREW VOLUMES

Half Batch – 38 OZ

Full Batch – 76 OZ

DILUTION VOLUMES

Half Batch – 160 OZ

Full Batch – 320 OZ

DILUTION DELAY

Half Batch – 0:00

Full Batch – 0:00

PULSE BREW TIMES

Half Batch – Disabled

Full Batch – Disabled

DRIP OUT TIMES

Half Batch – 1:55

Full Batch – 2:40

TEA 3 RECIPE:

BREW VOLUMES

Half Batch – 45 OZ

Full Batch – 90 OZ

DILUTION VOLUMES

Half Batch – 160 OZ

Full Batch – 320 OZ

DILUTION DELAY

Half Batch – 0:00

Full Batch – 0:00

PULSE BREW TIMES

Half Batch – Manual :30/:15/:15

Full Batch – Manual :30/:15/:15

DRIP OUT TIMES

Half Batch – 1:00

Full Batch – 1:20

PROGRAMMING THE BREWER (cont.)
PROGRAMMING FUNCTIONS - LEVEL 2 (cont.)

FACTORY DEFAULT VALUES (Continued)

HOT TEA RECIPE:

BREW VOLUMES
Half Batch - 64 OZ
Full Batch - 64 OZ

PULSE BREW TIMES

Half Batch - Manual :30/:15/:15
Full Batch - Manual :30/:15/:15

DRIP OUT TIMES

Half Batch - 1:15
Full Batch - 1:15

ICED COFFEE RECIPE:

BREW VOLUMES
Half Batch - 64 OZ
Full Batch - 64 OZ

DILUTION VOLUMES

Half Batch - 0 OZ
Full Batch - 0 OZ

DILUTION DELAY

Half Batch - 0:00
Full Batch - 0:00

PULSE BREW TIMES

Half Batch - Disabled
Full Batch - Manual :45/:10/:15

DRIP OUT TIMES

Half Batch - 1:00
Full Batch - 1:30

NO-NAME COFFEE RECIPE:

BREW VOLUMES

Half Batch - 64 OZ
Full Batch - 64 OZ

PULSE BREW TIMES

Half Batch - Manual :40/:10/:26
Full Batch - Manual :40/:10/:26

DRIP OUT TIMES

Half Batch - 1:00
Full Batch - 1:00

Master Temp - 205°

Ready Temp - 5°

Enable Ads - Disabled

Enable Sanitation - Disabled

Enable Energy Saver Mode - Disabled

IDLE - 4 HRS, THEN 140°

Enable Freshness Timer - Disabled

TEA - 8 HRS

HOT TEA - 2 HRS

ICED COFFEE - 4 HRS

COFFEE - 2 HRS

Spray Oz/m - 26

Dilution Oz/m - 73

Recipe Temps

TEA 1 - 205°

TEA 2 - 205°

TEA 3 - 205°

HOT TEA - 205°

ICED COFFEE - 200°

COFFEE - 200°

TROUBLESHOOTING

A troubleshooting guide is provided to suggest probable causes and remedies for the most likely problems encountered. If the problem remains after exhausting the troubleshooting steps, contact the Bunn-O-Matic Technical Service Department.

- Inspection, testing, and repair of electrical equipment should be performed only by qualified service personnel.
- All electronic components have 120-240 volt ac and low voltage dc potential on their terminals. Shorting of terminals or the application of external voltages may result in board failure.
- Intermittent operation of electronic circuit boards is unlikely. Board failure will normally be permanent. If an intermittent condition is encountered, the cause will likely be a switch contact or a loose connection at a terminal or crimp.
- Solenoid removal requires interrupting the water supply to the valve. Damage may result if solenoids are energized for more than ten minutes without a supply of water.
- The use of two wrenches is recommended whenever plumbing fittings are tightened or loosened. This will help to avoid twists and kinks in the tubing.
- Make certain that all plumbing connections are sealed and electrical connections tight and isolated.
- This brewer is heated at all times. Keep away from combustibles.

- WARNING** –
- Exercise extreme caution when servicing electrical equipment.
 - Unplug the brewer when servicing, except when electrical tests are specified.
 - Follow recommended service procedures.
 - Replace all protective shields or safety notices.

TROUBLESHOOTING (cont.)

PROBLEM	PROBABLE CAUSE	REMEDY
Temperature Too Low	1. Water temperature in the tank does not meet the ready temperature.	A) Wait for the brewer to heat to the proper temperature. B) Disable the BREW LOCKOUT function. See page 17 for procedure.
Heating Time Too Long	1. Tank Heater failure. 2. Control Board/Thermistor failure	Service required Service required
Fill Time Too Long	1. Water shut off to brewer 2. Tank Drain clamp is shut 3. Inlet Solenoid failure 4. Control Board Failure 5. ON/OFF switch is OFF	Check water supply shut-off Check tank drain clamp Service Required Service Required Turn switch ON
Temp Sensor Out Of Range, Check For Bad Connections	1. Temperature Sensor Probe wire(s) broken or not making connection	Check wire and connection of both black and white wires of temperature probe.
Temp Sensor Out Of Range, Check Wire For Shorts	1. Temperature Sensor Probe wire(s) shorted to housing or to each other.	Check to confirm that wire(s) are not pinched between two surfaces or connected to each other.
Equipment will not operate	1. No power or incorrect voltage	Measure the voltage at the terminal block and confirm that it matches the voltage specified on the brewer data plate withing +/- 10%.

TROUBLESHOOTING (cont.)

<u>PROBLEM</u>	<u>PROBABLE CAUSE</u>	<u>REMEDY</u>
Brew cycle will not start	1. No water	Check plumbing and shut-off valves
	2. No power or incorrect voltage to the brewer	Check for voltage across the terminals at the terminal block.
	3. ON/OFF switch	Test the ON/OFF switch. Refer to the test switch procedures on page 58.
	4. Brew switch	Test the BREW switch. Refer to the test switch procedures on page 57.
	5. Brew valve	Test the brew valve. Refer to the test outputs procedures on page 56.
	6. Control Board	Substitute a control board known to be in good working order.

TROUBLESHOOTING (cont.)

PROBLEM	PROBABLE CAUSE	REMEDY
Automatic refill will not operate or display shows FILL TIME TOO LONG	<ol style="list-style-type: none"> 1. No water 2. Tank drain clamp 3. Water Strainer 4. Refill probe or Sensitivity setting 5. Refill valve 	<p>Check plumbing and shut-off valves</p> <p>Check tank drain clamp</p> <p>Direction of flow arrow must be pointing towards direction of water flow.</p> <p>Remove the strainer and check for obstructions. Clear or replace.</p> <p>Check the sensitivity setting. Refer to the REFILL function on page 47. If the left three digit number is less than the right number, the machine “thinks” it is full and the refill valve should be off. If the left number is larger than the right, then the refill valve will automatically be turned on to fill the tank. The right number is the threshold setting and can be adjusted to compensate for extreme water conditions: very pure, low conductance water requires a higher setting, while high mineral content, high conductance water requires a lower setting. Note that the left number changes from a high value when water is NOT touching the refill probe to a low value when water IS touching the probe. For best operation, the right number should be set to a value midway between these low and high numbers. Before changing the setting, confirm that the refill probe is free of scale buildup and the connection to it is</p>

TROUBLESHOOTING (cont.)

PROBLEM

Automatic refill will not operate or display shows FILL TIME TOO LONG (Continued)

PROBABLE CAUSE

5. Refill valve (Continued)

6. Control Board

7. ON/OFF Switch

REMEDY

secure. Test the refill valve. Refer to the test outputs procedures on page 56.

Refill valve – Disconnect the brewer from the power source and remove wires from refill valve coil. Check for continuity across the terminals of the solenoid coil. If continuity is not present, replace the refill valve. If continuity is present, the coil may be stuck closed. Shut water off to brewer. Press the ON/OFF switch to turn off the brewer. Open the faucet and drain water down in the tank until flow stops or slows to a trickle. Attach a voltmeter to the terminals of the refill solenoid. Connect the brewer to the power source. Press the ON/OFF switch to turn the brewer on. Within five seconds, voltage should be present at the solenoid terminals. If voltage is not present, refer to the wiring schematic and check the wiring harness.

Substitute a control board known to be in good working order.

TROUBLESHOOTING (cont.)

<u>PROBLEM</u>	<u>PROBABLE CAUSE</u>	<u>REMEDY</u>
Water flows into tank continuously with power removed from brewer.	1. Refill valve	Foreign material lodged in valve, holding it in open state.
	2. Refill probe or sensitivity setting	Check the sensitivity setting. Refer to the REFILL function on page 47. If the left three digit number is less than the right number, the machine "thinks" it is full and the refill valve should be off. If the left number is larger than the right, then the refill valve will automatically be turned on to fill the tank. The right number is the threshold setting and can be adjusted to compensate for extreme water conditions: very pure, low conductance water requires a higher setting, while high mineral content, high conductance water requires a lower setting. Note that the left number changes from a high value when water is NOT touching the refill probe to a low value when water IS touching the probe. For best operation, the right number should be set to a value midway between these low and high numbers. Before changing the setting, confirm that the refill probe is free of scale buildup and the connection to it is secure.
	3. Control Board	Substitute a control board known to be in good working order.

TROUBLESHOOTING (cont.)

<u>PROBLEM</u>	<u>PROBABLE CAUSE</u>	<u>REMEDY</u>
Water will not heat or display shows HEATING TIME TOO LONG.	1. Limit Thermostat	Remove power from the brewer. Check for continuity through the limit thermostat. CAUTION: Do not eliminate or bypass limit thermostat. Use only replacement part 29329.0001.
	2. Temperature probe	Remove the probe from the grommet and submerge in a water bath of approximately 70°F (21°C). Connect an ohmmeter to the pins in the connector. At 60°F (16°C), the reading should be 15.3k ± 2k OHMS, at 70°F (21°C) the reading should be 11.8k ± 2k OHMS, and at 80°F (27°C) the reading should be 9.3k ± 2k OHMS. If the probe is within these parameters, reconnect to the control board.
	3. Toggle switch	Check that the toggle switch connections are secure and properly wired. Check the toggle switch selects the correct voltage.

TROUBLESHOOTING (cont.)

<u>PROBLEM</u>	<u>PROBABLE CAUSE</u>	<u>REMEDY</u>
Water will not heat or display shows HEATING TIME TOO LONG. (Continued)	4. Tank heaters	Remove power from the brewer. Check for continuity between the white terminal of the terminal block (or red terminal on 208/240V models) and the black wire on the relay on the control board (Toggle switch must be in 120/208-240V position on 208V and 240V models). There should be a low OHM reading. If not continuity is present, check for a wiring or switch problem (consult wiring schematic), then replace the tank heater if no wiring or switch problem is found.
	5. Control Board	Remove power from the brewer. Connect a voltmeter across the tank heater. Reapply power to the brewer and refer to testing outputs on page 56. If the voltage measured when the tank heater is turned on is very low or zero, then substitute a control board known to be good working order.

TROUBLESHOOTING (cont.)

<u>PROBLEM</u>	<u>PROBABLE CAUSE</u>	<u>REMEDY</u>
Dilution cycle will not start	1. Dilution valve	Test the dilution valve. Refer to the test outputs procedures on page 56.
	2. Recipe settings	Check to make sure the current recipe has a dilution volume set. Coffee recipes will not have dilution.
	3. Strainer	Direction of flow arrow must be pointing towards the brewer. Remove the strainer and check for obstructions. Clear or replace.

TROUBLESHOOTING (cont.)

PROBLEM	PROBABLE CAUSE	REMEDY
Spitting or unusual steaming from sprayhead or air vent.	1. Lime buildup	Inspect the probe and tank assembly for excessive lime deposits. Delime as required.
	2. Temperature probe	Remove the probe from the grommet and submerge in a water bath of approximately 70°F (21°C). Connect an ohmmeter to the pins in the connector. At 60°F (16°C), the reading should be 15.3k ± 2k OHMS, at 70°F (21°C) the reading should be 11.8k ± 2k OHMS, and at 80°F (27°C) the reading should be 9.3k ± 2k OHMS. If the probe is within these parameters, reconnect to the control board.
	3. Control Board	Remove power from the brewer. Connect a voltmeter across the tank heater. Reapply power to the brewer and refer to testing outputs on page 56. If the voltage measured when the tank heater is turned on is very low or zero, then substitute a control board known to be good working order.
Dripout time too long	1. Funnel tip	The brew funnel should be cleaned thoroughly before each brew cycle to lessen the chance of tealeaf or ground particles clogging the dripout tip.

TROUBLESHOOTING (cont.)

<u>PROBLEM</u>	<u>PROBABLE CAUSE</u>	<u>REMEDY</u>
Inconsistent beverage level in server/dispenser	1. Strainer	Direction of flow arrow must be pointing towards the brewer. Remove the strainer and check for obstructions. Clear or replace.
	2. Improper water pressure	Check operating water pressure to the brewer. It must be between 20 and 90 psi (138 and 620 kPa).
	3. Brew valve	Test the brew valve. Refer to test outputs on page 56. Turn the valve on for 30 seconds and collect the water dispensed from the spray-head. Repeat the test several times to confirm a consistent volume of dispensed water. If not consistent, check the valve, tubing and spray-head for lime buildup.
	4. Dilution valve	If dilution is being used on the inconsistent brewing recipe, test the dilution valve. Refer to test outputs on page 56. Turn the valve on for 30 seconds and collect the water collected from the nozzle. Repeat the test several times to confirm a consistent volume of dispensed water. If not consistent, check the valve, tubing and nozzle for lime buildup.
	5. Lime buildup	Inspect for lime buildup that could block the tank, tank fittings, tubing, valves and sprayhead.
	6. Brew volume adjustment	Adjust the brew volume as required to achieve the recommended volume for each brew cycle.

TROUBLESHOOTING (cont.)

<u>PROBLEM</u>	<u>PROBABLE CAUSE</u>	<u>REMEDY</u>
Dripping from sprayhead.	1. Brew valve	Repair or replace leaky valve
Water overflows filter.	1. Type of paper filter	BUNN paper filters should be used for proper extraction
	2. No sprayhead	Check sprayhead
Beverage overflows server.	1. Beverage left in server from previous brew	The brew cycle should be started only with an empty server under the funnel.
	2. Brew volume adjustment	Adjust the brew volumes as required to achieve the recommended volume for each brew cycle.

TROUBLESHOOTING (cont.)

<u>PROBLEM</u>	<u>PROBABLE CAUSE</u>	<u>REMEDY</u>
Weak beverage.	1. Type of paper filter	BUNN paper filters should be used for proper extraction
	2. Coffee or tealeaves	For coffee, a sufficient quantity of fresh drip or regular grind should be used for proper extraction. For tea, a sufficient quantity of fresh, loose tea leaves should be used for proper extraction.
	3. Sprayhead	Bunn-O-Matic sprayhead should be used to properly wet the bed of ground coffee or tealeaves in the funnel
	4. Funnel Loading	The BUNN paper filter should be centered in the funnel and the bed of grounds or tealeaves leveled by gently shaking.
	5. Water temperature	Empty the server, remove its cover, and place the server beneath the sprayhead. Place empty funnel over the server entrance (not in the funnel rails). Press brew. Check the water temperature immediately below the sprayhead with a thermometer. The reading should not be less than 195°F (90.5° C).
	6. Incorrect recipe	Consider adjusting brew volumes, dilution volumes, dilution delay and pulse brew routines. Contact Bunn-O-Matic for suggestions.

TROUBLESHOOTING (cont.)

<u>PROBLEM</u>	<u>PROBABLE CAUSE</u>	<u>REMEDY</u>
Brewer is making unusual noises.	1. Solenoids	The mounting screws on the solenoids must be tight or they will vibrate during operation
	2. Plumbing lines	Plumbing lines should not be resting on the countertop.
	3. Water supply	The brewer must be connected to a cold water line. Water pressure to the brewer must not be higher than 90 psi (620 kPa). Install a regulator if necessary to lower the working pressure to approximately 50 psi (345 kPa).
	4. Tank heaters	Remove and clean lime off tank heaters.

SCHEMATIC WIRING DIAGRAM ITCB-DV

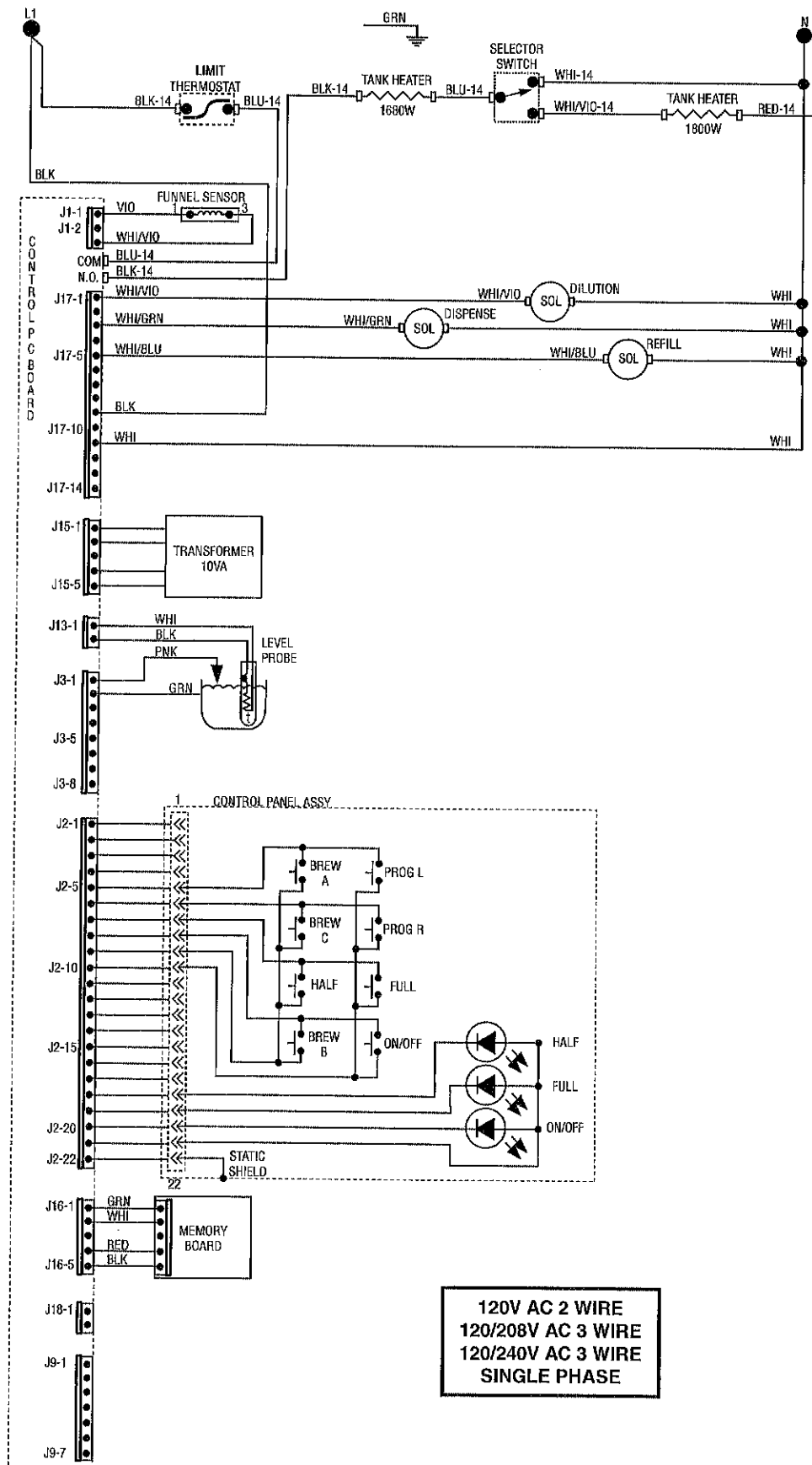

120V AC 2 WIRE
120/208V AC 3 WIRE
120/240V AC 3 WIRE
SINGLE PHASE

SCHEMATIC WIRING DIAGRAM ITCBA, ITCBB

