

# ATH845

TELEHANDLER



**ATLAS**  
— IRON CE —



## Specification

### Capacities

Max. capacity	8818 lbs
Max. lifting height	45.3 ft
Max. outreach	23.0 ft

### Weight and dimensions

Overall length to carriage	l11	21.0 ft
Length to face of forks	l1	25.0 ft
Min transport size	l12	18.4 ft
Overall width	b1	7.7 ft
Track width	b2	6.4 ft
Overall height	h17	8.4 ft
Wheelbase	y	11.8 ft
Ground clearance	m4	1.2 ft
Overall cab width	b4	2.8 ft
Tilt-up angle	a4	12 °
Tilt-down angle	a5	90 °
External turning radius(over tyres)	—	13.5 ft
Unladen weight(with fork)	—	28660 lbs
Tires type	—	Tubeless
Standard tires	l/e/s	440/80-24
Forks length/ width/ section	—	4.0 ft x 0.4 ft / 0.2 ft

### Performances

Lifting	16 s
Lowering	12.4 s
Extension	17.3 s
Retraction	13 s
Crowd	4.8 s
Dump	4.0 s

### Engine

Engine brand	Deutz
Engine norm	EPA 4
Displacement	220 cu in
Engine model	TCD3.6 L4
Number of cylinders	4
I.C. Engine power rating - Power	121 hp
Max. torque	354lb/ft 2000 rpm

### Transmission

Transmission type	Torque converter (optional hydrostatic)
Number of gears (forward / reverse)	4 / 4
Max. travel speed	40 km/h
Parking brake	Automatic air-cut brake (optional wet disc brake)
Service brake	immersed multi-discs braking on front & rear axles

### Hydraulics

Hydraulic pump type	Gear pump (optional piston pump)
Hydraulic flow	31.7 gal

### Tank capacities

Engine oil	1.5 gal
Hydraulic oil	44.9 gal
Fuel tank	51.5 gal

### Noise and vibration

Noise at driving position (LpA)	79 dB
Noise to environment (LwA)	106 dB
Vibration on hands / arms	< 2.50 m/s <sup>2</sup>

### Miscellaneous

Steering wheels (front / rear)	2 / 2
Drive wheels (front / rear)	2 / 2
Safety cab homologation	FOPS level 2 cab

\*Parameters and dimensions are subject to the actual product

# ATH845

TELEHANDLER



**ATLAS**  
IRON CE

## DIMENSIONS

All dimensions are approximate

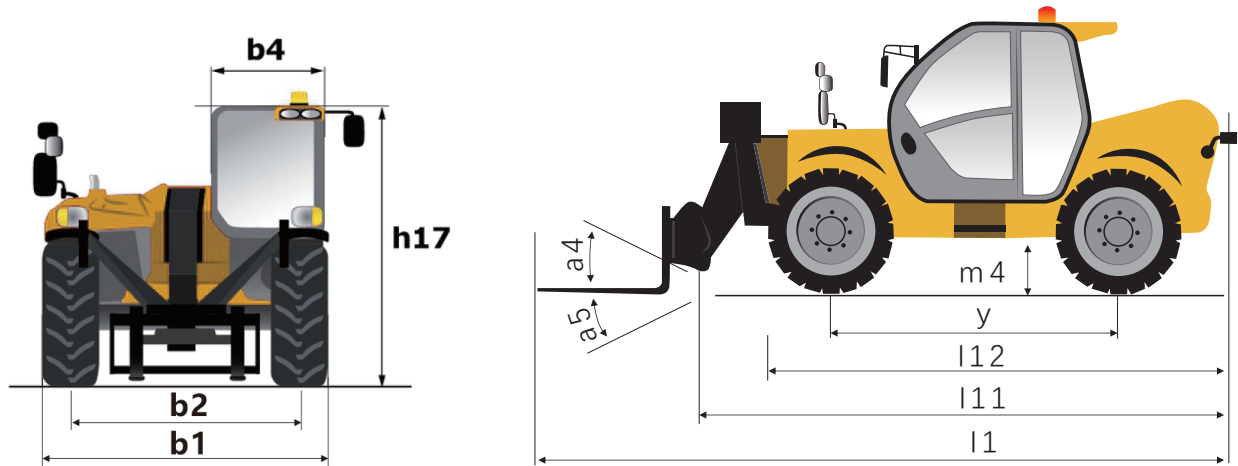

## LOAD CHART

Machine on tyres with forks - with levelling device Metric

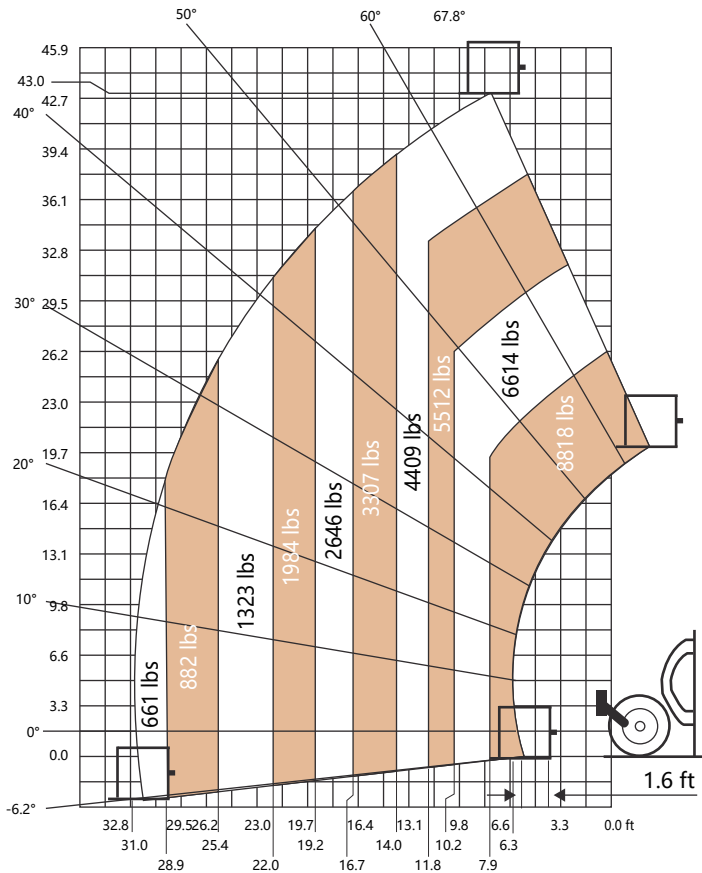

Machine on lowered stabilisers with forks Metric

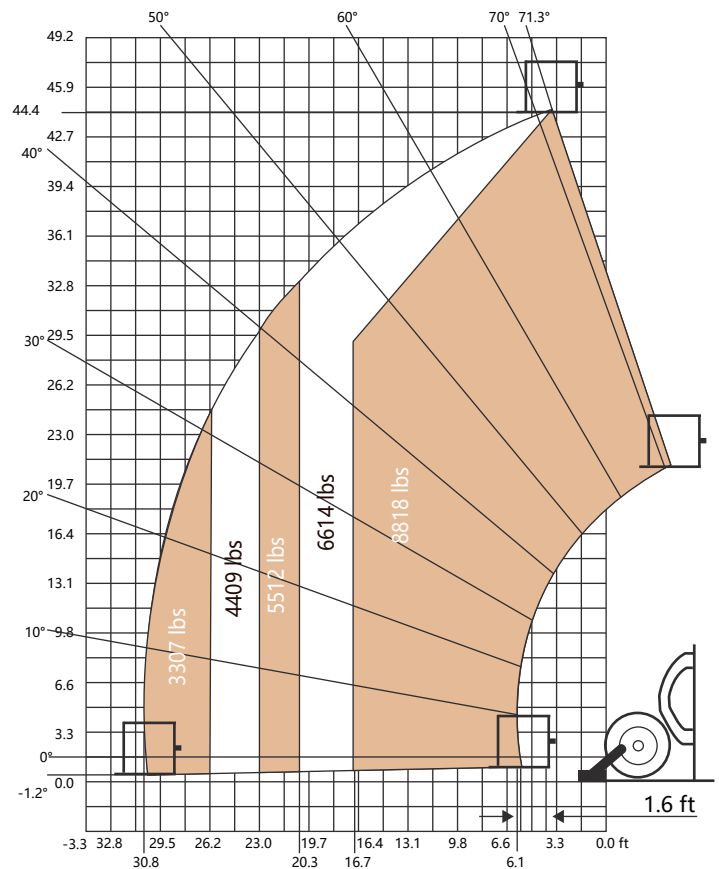

# ATH845

TELEHANDLER



**ATLAS**  
— IRON CE —

## ATTACHMENTS



**CrassCutter**



**Rallet fork**

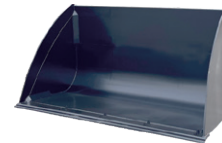

**Bucket**



**Mixed bucket**



**Crane Arm**



**Snow Blower**



**Mixed barrel**



**Road Roller**



**BaleFork**



**Road Sweeper**



**Grapple bucket**

Pleasant Working Environment



lift cylinder



High shear forces



Easy to open engine hoo

