



Europe - 2026

# Catalog

Ovens, accessories  
and consumables

**PRÁTICA**  
EUROPE

# Welcome to *Prática*



Prática, founded in 1991, offers advanced equipment for the food preparation market, with a broad product portfolio that includes a strong range of speed ovens. The company operates a fully integrated 250,000 sq. ft. manufacturing facility in Minas Gerais, Brazil, employing more than 700 team members—55 of whom are dedicated to Research & Development.

Prática maintains a growing international presence with branches in the United States, Europe, and Chile, and exports its products to over 60 countries worldwide.

Our purpose is to empower customers to prepare high-quality food without waste. We understand the important role we play in the food chain that begins in the fields where crops are grown and ends when food is prepared and served. Through state-of-the-art technology, integrated product solutions, and robust pre- and post-sales support, we enhance our customers' operations in quality, productivity, and profitability.

Guided by strong values, a unified team, and a forward-looking vision, Prática is steadily advancing toward an increasingly prominent position in the global foodservice industry.

# Purpose

Prática's purpose is to help our customers prepare **quality food without waste**.

This purpose, also a commitment, unfolds into three complementary dimensions: well-being, productivity, and preservation. We believe that when we execute our work with excellence and stay true to this purpose, we contribute to the well-being of people, support growth and development opportunities for our customers, and help preserve our shared home: planet Earth.

Quality food  
without waste.



Well-being



Productivity



Sustainability

# Vision

To be a world-class company with global impact, recognized for excellence in our service, products, operations, and leadership.

# Values



COMPETITIVENESS



DEDICATION TO  
THE CUSTOMER



RESPECT



AGILITY



COMMITMENT



PROACTIVITY



WILLINGNESS  
TO IMPROVE



INNOVATION



SPIRIT OF  
COLLABORATION



HONESTY AND  
INTEGRITY



AUSTERITY



GRATITUDE

# Present in over 60 countries

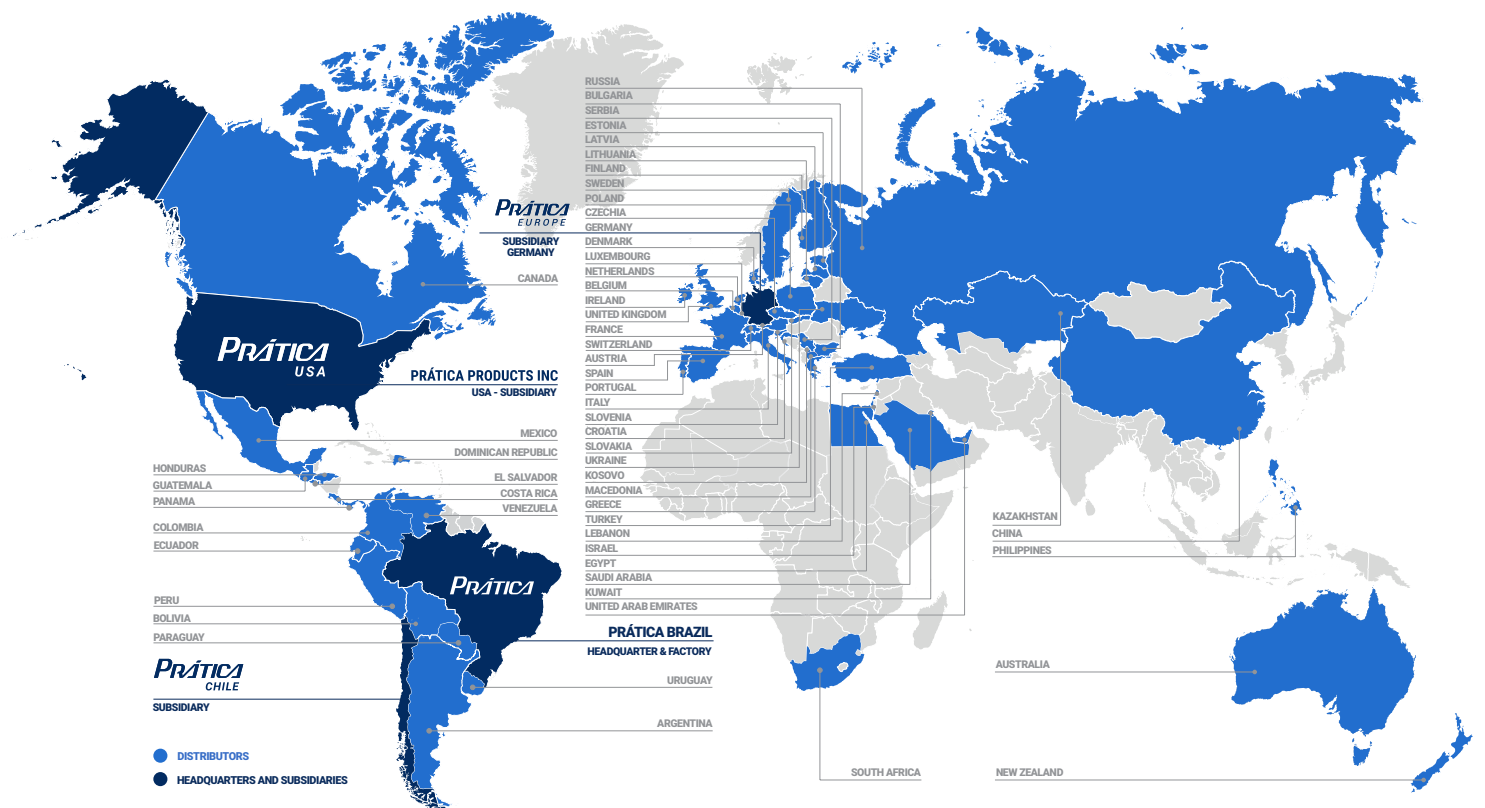

 Zoom in to get a better view.





**8** Fit Express

**10** Fit Lite

**12** Fit SM

**14** Fit XL

**16** Fit ST

**20** Forza STi

**24** Technology

**30** Accessories

# Speed Ovens

Prática's speed ovens are ultra-fast, high-performing ovens used for preparing and finishing fresh, refrigerated, or frozen foods. Each use results in excellent appearance, crunchiness, and taste.

With cutting-edge technology, the ovens work with multiple heat sources, such as impinged hot air, microwave, and direct radiation. They are equipped with a ventless system through an easily removable catalytic converter and require no extraction hood for operation, making it easy to clean and maintain.

With a friendly touchscreen interface, Prática speed ovens have easy operation and quick preparations and are ideal for service with agility and quality.



Fit Line

# Fit Express

The Fit Express high-speed oven is designed to efficiently finish refrigerated, fresh, or frozen foods, such as breakfast sandwiches, chicken wings, muffins, lasagnas, mac & cheese, sub sandwiches, and other partially prepared dishes. It delivers excellent flavor, appearance, and crispiness. The combination of impinged air and microwaves allows for heating, browning, or toasting foods faster than traditional methods.



## Colors

Fit Express Black

Fit Express Silver

- ✔ Fits on 15.2" width countertops and cooks 12" pizzas.
- ✔ **User interface:** full-color user-friendly touchscreen display. Drag and drop features.
- ✔ **IOK:** Create, edit, and organize groups, recipes, and complete menus directly on the oven or from your computer using Wi-Fi or USB flash drive and send them to all connected ovens.
- ✔ **Multi-language system:** Portuguese, English, Spanish, French, German, Polish, Russian, Mandarin, Greek.
- ✔ **Ventless:** no hoods needed.
- ✔ The **removable catalytic converter** allows operators to perform the cleaning without the need for a maintenance service call.
- ✔ **Secures consistent results:** through precise control, even heat distribution, rapid cooking, built-in sensors, and customization options, ensuring uniform and efficient cooking for reliable outcomes.
- ✔ **Independently adjust** microwave power, temperature, and impinged air while programming recipes on the oven.
- ✔ **No side vents,** allowing zero side clearance.
- ✔ **Elegant & Intuitive:** Stores unlimited recipes, with their own steps, settings, icons, or photos.
- ✔ **Temperatures up to 536°F:** The impinged air convection technology combined with microwave capabilities enables users to cook food faster than when using traditional processes.
- ✔ **Heat insulation:** prevents the surrounding area from heating up and keeps the surface cool to the touch.

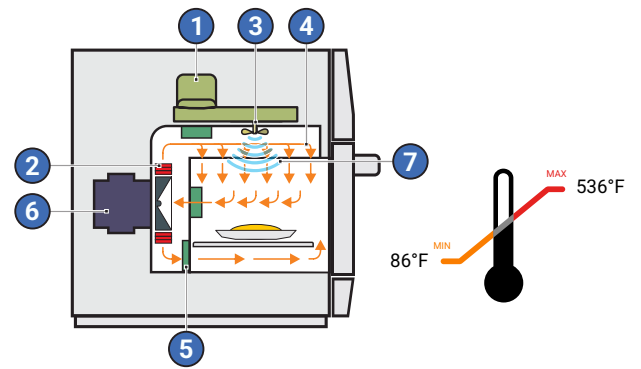

- 1. Magnetron
- 2. Resistance (infrared)
- 3. Stirrer
- 4. Impinged Air
- 5. Catalytic Converter
- 6. Blower Motor
- 7. Microwaves

## Cook Times

Ham & Cheese Panini	<b>50 sec</b>
Italian Sub	<b>55 sec</b>
Fresh Omelet	<b>1 min 30 sec</b>
Frozen Pizza 30cm	<b>2 min</b>
Steamed Salmon	<b>2 min 30 sec</b>



CERTIFIED  
**VENTLESS**  
WITH EASILY REMOVABLE  
CATALYTIC CONVERTER.

### Standard accessories



**BUILT-IN**  
Speed Grill



Aluminum Paddle



Solid Basket



**Click to learn more**

 **1 year warranty** for parts and labor, with the exception of naturally worn items.

Fit Express											
Region	Voltage (V)	Phases	Freq. (Hz)	Power (kW)	Circuit breaker (A)	Cable	Socket	Product dimensions (Height x Width x Depth)	Boxed product dimensions (Height x Width x Depth)	Chamber dimensions (Height x Width x Depth)	Clearance (Left   Back   Right side)
Europe	230	Single	50	6.8	32	3x4	32A(2P+E)	659 x 386 x 693 (mm) <b>71.3kg</b>	850 x 510 x 900 (mm) <b>87kg</b>	133 x 315 x 308 (mm) <b>13L</b>	0 / 0 / 0 (mm)
	380	Multi		6.5	16	5x2,5	16A(3P+N+E)				
	400	Multi		6.8	16	5x2,5	16A(3P+N+E)				

\*Prática recommends installing a type D circuit breaker. The electrical installation must comply with local regulations.



## Fit Line **Fit Lite**

The Fit Lite high-speed oven is designed for the regeneration and finishing of fresh or refrigerated food items, such as sandwiches, pizzas, pastries, and other pre-prepared products. It delivers consistent results in heating, browning, and gratinating, ensuring uniform appearance and texture. By combining high-speed impinged air with microwave energy, the Fit Lite reduces preparation time compared to traditional cooking methods while maintaining product quality. The Fit Lite is not recommended for frozen food.



# Colors

Fit Lite Silver

- ❖ **Ideal for fresh or refrigerated food items.** Not recommended for frozen food.
- ❖ Designed for **regeneration, finishing, and gratination** of pre-prepared food.
- ❖ Countertop speed oven developed for **commercial foodservice applications.**
- ❖ Cooking technology combines **high-speed impinged air and microwave energy** for faster preparation compared to conventional methods.
- ❖ **User interface:** full-color touchscreen display for recipe selection and operation.
- ❖ **Recipe programming:** independently adjust microwave power, temperature, air speed, and cooking time.
- ❖ **Multi-step recipes:** allows up to 8 programmable steps per recipe.
- ❖ Recipe and settings transfer via **USB flash drive.**
- ❖ **Manual mode available** for testing preparations and developing new recipes.
- ❖ **Speed Grill** required during operation to ensure proper cooking performance.
- ❖ Maximum temperature up to **280°C (536°F).**

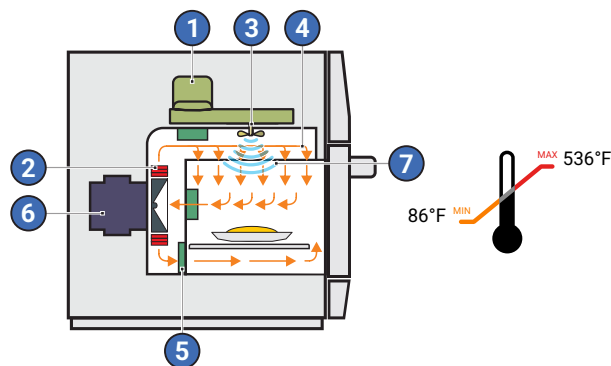

- 1. Magnetron
- 2. Resistance (infrared)
- 3. Stirrer
- 4. Impinged Air
- 5. Catalytic Converter
- 6. Blower Motor
- 7. Microwaves

## Cook Times

Pastries	<b>25 sec</b>
Sub Sandwiches	<b>1 min</b>
Hot Dog	<b>50 sec</b>
Paninis	<b>1 min</b>



### Standard accessories



**1 year warranty** for parts and labor, with the exception of naturally worn items.

Fit Lite											
Region	Voltage (V)	Phases	Freq. (Hz)	Power (kW)	Circuit breaker (A)	Cable	Socket	Product dimensions (Height x Width x Depth)	Boxed product dimensions (Height x Width x Depth)	Chamber dimensions (Height x Width x Depth)	Clearance (Left   Back   Right side)
United Kingdom	230	Single	50	3	13	3x1,5	13A(2P+E)	619 x 386 x 680 (mm) <b>56kg</b>	850 x 510 x 900 (mm) <b>72kg</b>	133 x 315 x 308 (mm) <b>13L</b>	0 / 0 / 0 (mm)
Europe	230	Single	50	3.4	16	3x2,5	16A(2P+E)	619 x 386 x 680 (mm) <b>56kg</b>	850 x 510 x 900 (mm) <b>72kg</b>	133 x 315 x 308 (mm) <b>13L</b>	0 / 0 / 0 (mm)

\*Prática recommends installing a type D circuit breaker. The electrical installation must comply with local regulations.



## Fit Line **Fit SM** Single mag

The Fit Single Mag high-speed oven is designed to efficiently finish refrigerated or fresh food items, such as breakfast sandwiches, pizzas, sub sandwiches, pastries and more! It delivers excellent flavor, appearance, and crispiness. The combination of impinged air and microwaves allows for heating, browning, or toasting foods faster than traditional methods. The Fit SM is not recommended for frozen food.



# Colors

Fit SM Silver

- ✔ **Ideal for fresh or refrigerated food items.** Not recommended for frozen food.
- ✔ **Energy efficient:** It is designed to be energy-efficient, so you save money on electricity compared to other models.
- ✔ Fits on 15.2" width countertops and cooks 12" pizzas and sandwiches.
- ✔ **User interface:** full-color user-friendly touchscreen display. Drag and drop features.
- ✔ **IOK:** Create, edit, and organize groups, recipes, and complete menus directly on the oven or from your computer using Wi-Fi or USB Flash Drive and send them to all connected ovens.
- ✔ **Ventless:** no hoods needed.
- ✔ The **removable catalytic converter** allows operators to perform the cleaning without the need for a maintenance service call.
- ✔ **Independently adjust** microwave power, temperature, and impinged air while programming recipes on the oven.
- ✔ **No side vents,** allowing zero side clearance.
- ✔ **Elegant & Intuitive:** Stores unlimited recipes, with their own steps, settings, icons, or photos.
- ✔ **Temperatures up to 536°F:** The impinged air convection technology combined with microwave capabilities enables users to cook food faster than when using traditional processes.
- ✔ **Heat insulation:** prevents the surrounding area from heating up and keeps the surface cool to the touch.

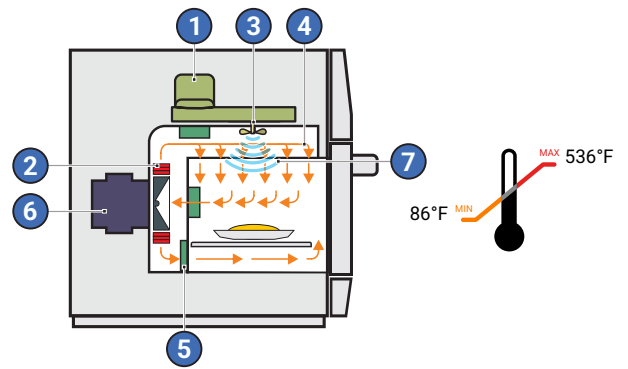

- 1. Magnetron
- 2. Resistance (infrared)
- 3. Stirrer
- 4. Impinged Air
- 5. Catalytic Converter
- 6. Blower Motor
- 7. Microwaves

## Cook Times

Pastries	25 sec
Sub Sandwiches	40 sec
Hot Dog	50 sec
Paninis	1 min 10 sec



**CERTIFIED**  
**VENTLESS**  
WITH EASILY REMOVABLE CATALYTIC CONVERTER.

### Standard accessories



[Click to learn more](#)

**1 year warranty** for parts and labor, with the exception of naturally worn items.

Fit SM Single Mag											
Region	Voltage (V)	Phases	Freq. (Hz)	Power (kW)	Circuit breaker (A)	Cable	Socket	Product dimensions (Height x Width x Depth)	Boxed product dimensions (Height x Width x Depth)	Chamber dimensions (Height x Width x Depth)	Clearance (Left   Back   Right side)
Europe	230	Single	50	3	13 16	3x1,5	13A(2P+E) 16A(2P+E)	619 x 386 x 693 (mm) <b>62kg</b>	850 x 510 x 900 (mm) <b>77.7kg</b>	133 x 315 x 308 (mm) <b>13L</b>	0 / 0 / 0 (mm)

\*Prática recommends installing a type D circuit breaker. The electrical installation must comply with local regulations.



## Fit Line Fit XL

The Fit XL high-speed oven features a 16-inch chamber and is designed to efficiently finish refrigerated, fresh, or frozen foods, such as breakfast sandwiches, chicken wings, muffins, lasagnas, mac & cheese, sub sandwiches, and other partially prepared dishes. Capable of handling larger portions, it is ideal for medium and large businesses. The Fit XL delivers excellent flavor, appearance, and crispiness. By combining impinged air and microwaves, it heats, browns, and toasts foods faster than traditional methods.



# Colors

Fit XL Black  
Fit XL Silver

BACK TO MENU

- ❖ 16-inch chamber.
- ❖ Capable of handling larger portions, it is ideal for medium and large businesses.
- ❖ Stores **unlimited recipes** with up to 8 steps each, divided into 16 groups.
- ❖ **USB port** for system updates and importing/exporting groups, recipes, and settings.
- ❖ **Wi-Fi capabilities**, enabling remote management for system updates and importing/exporting groups, recipes, and settings via the IOK online platform.
- ❖ **Adjustable temperature** from 86°F (30°C) to 536°F (280°C).
- ❖ **Independent control** of impinged air (high-speed air blast) and microwaves.
- ❖ **User-friendly touchscreen panel.**
- ❖ Constructed from **stainless steel.**
- ❖ **Certified Ventless** – no need for vent hoods. Easy-to-remove catalytic converter for hassle-free cleaning.
- ❖ **Additional functionalities:** Test Mode and Favorites.
- ❖ Daily cleaning guide with explanatory **videos displayed on the screen**, demonstrating the step-by-step process.
- ❖ **Warranty:** one (1) year covering manufacturer defects, part failures, and pre-approved labor, and two (2) years on all the heating elements, magnetrons, and blower motor of the oven.

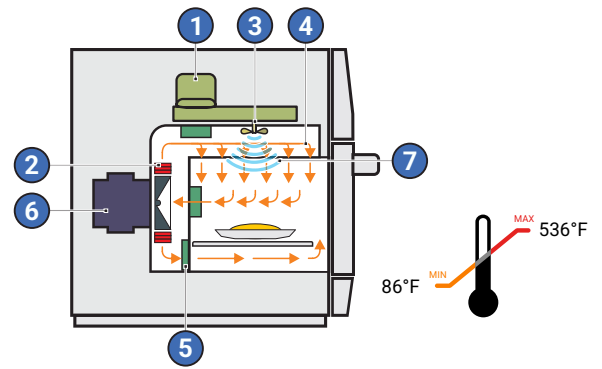

- 1. Magnetron
- 2. Resistance (infrared)
- 3. Stirrer
- 4. Impinged Air
- 5. Catalytic Converter
- 6. Blower Motor
- 7. Microwaves

## Cook Times

Frozen Pizza 40cm	<b>3 min 30 sec</b>
3 Sub Sandwiches	<b>1 min</b>
6 Paninis	<b>1 min 30 sec</b>
Frozen Fries 900g	<b>4 min 30 sec</b>



**CERTIFIED**  
**VENTLESS**  
 WITH EASILY REMOVABLE  
 CATALYTIC CONVERTER.

### Standard accessories

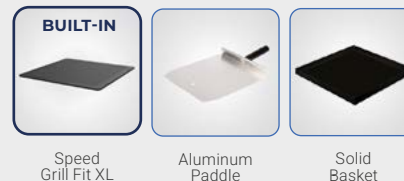

[Click to learn more](#)

Fit XL											
Region	Voltage (V)	Phases	Freq. (Hz)	Power (kW)	Circuit breaker (A)	Cable	Socket	Product dimensions (Height x Width x Depth)	Boxed product dimensions (Height x Width x Depth)	Chamber dimensions (Height x Width x Depth)	Clearance (Left   Back   Right side)
Europe	230	Single	50	6.8	32	3x4	32A(2P+E)	658 x 488 x 795 (mm) <b>82kg</b>	905 x 590 x 960 (mm) <b>103kg</b>	139 x 417 x 410 (mm) <b>23.7L</b>	0 / 0 / 0 (mm)
	380	Multi		6.5	16	5x2,5	16A(3P+N+E)				
	400	Multi		6.8	16	5x2,5	16A(3P+N+E)				

\*Prática recommends installing a type D circuit breaker. The electrical installation must comply with local regulations.



## Fit Line **Fit ST** Stackable

The Fit ST high-speed oven features a 12-inch chamber and can be stacked up to two units high. It is designed to efficiently finish refrigerated, fresh, or frozen foods, such as breakfast sandwiches, chicken wings, muffins, lasagnas, mac & cheese, sub sandwiches, and other partially prepared dishes. Ideal for any business size, the oven delivers excellent flavor, appearance, and crispiness. By combining impinged air and microwaves, it heats, browns, and toasts foods faster than traditional methods.



## Colors

Fit ST Black

Fit ST Silver

- ✔ The FIT ST can be stacked up to 2 units (1+1).
- ✔ Stores unlimited recipes with up to 8 steps each, divided into 16 groups.
- ✔ USB port for system updates and importing/exporting groups, recipes, and settings.
- ✔ Wi-Fi capabilities, enabling remote management for system updates and importing/exporting groups, recipes, and settings via the IOK online platform.
- ✔ Adjustable temperature from 86°F (30°C) to 536°F (280°C).
- ✔ Independent control of impinged air (high-speed air blast) and microwaves.
- ✔ User-friendly touchscreen panel.
- ✔ Constructed from stainless steel.
- ✔ Certified Ventless – no need for vent hoods. Easy-to-remove catalytic converter for hassle-free cleaning.
- ✔ Additional functionalities: Test Mode and Favorites.
- ✔ Daily cleaning guide with explanatory videos displayed on the screen, demonstrating the step-by-step process.
- ✔ Warranty: one (1) year covering manufacturer defects, part failures, and pre-approved labor, and two (2) years on all the heating elements, magnetrons, and blower motor of the oven.

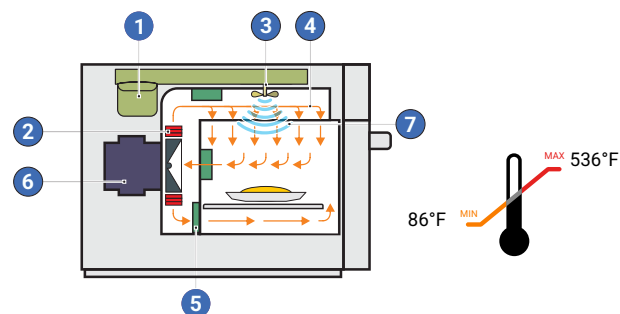

1. Magnetron
2. Resistance (infrared)
3. Stirrer
4. Impinged Air
5. Catalytic Converter
6. Blower Motor
7. Microwaves

## Cook Times

Ham & Cheese Panini	50 sec
Italian Sub	55 sec
Fresh Omelet	1 min 30 sec
Frozen Pizza 30cm	2 min
Steamed Salmon	2 min 30 sec



CERTIFIED

**VENTLESS**

WITH EASILY REMOVABLE CATALYTIC CONVERTER.

### Standard accessories

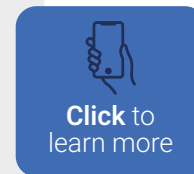

Fit ST Single Mag*											
Region	Voltage (V)	Phases	Freq. (Hz)	Power (kW)	Circuit Breaker (A)	Cable	Socket	Product dimensions (Height x Width x Depth)	Boxed product dimensions (Height x Width x Depth)	Chamber dimensions (Height x Width x Depth)	Clearance (Left   Back   Right side)
Europe	230	Single	50	3	13 16	3x1,5	13A(2P+E) 16A(2P+E)	425 x 518 x 697 (mm) 61kg	722 x 620 x 825 (mm) 83kg	133 x 315 x 308 (mm) 13L	0 / 0 / 25 (mm)

Fit ST Double Mag											
Region	Voltage (V)	Phases	Freq. (Hz)	Power (kW)	Circuit Breaker (A)	Cable	Socket	Product dimensions (Height x Width x Depth)	Boxed product dimensions (Height x Width x Depth)	Chamber dimensions (Height x Width x Depth)	Clearance (Left   Back   Right side)
Europe	230 380 400	Single Multi Multi	50	6.8 6.5 6.8	32 16 16	3x4 5x2,5 5x2,5	32A(2P+E) 16A(3P+N+E) 16A(3P+N+E)	425 x 518 x 697 (mm) 72kg	722 x 620 x 825 (mm) 94kg	133 x 315 x 308 (mm) 13L	0 / 0 / 25 (mm)

\*Prática recommends installing a type D circuit breaker. The electrical installation must comply with local regulations.

A C C E S S O R Y

# PANINI PRESS

For FIT Lite, FIT SM, FIT Express and FIT ST - USE ONLY





## The Panini Press is an optional accessory for the FIT Line, ideal for making delicious sandwiches and paninis with grill marks.

- ❖ Specifically designed for use with the FIT Lite, FIT Express, Fit SM, and Fit ST.
- ❖ It is constructed from aluminum and coated with a non-stick layer.
- ❖ Versatility: Accommodates a variety of foods with an opening range of 0.7" to 2.9" between the top and bottom grills.
- ❖ Create perfectly pressed, grill-marked paninis, melts, subs, burritos, quesadillas, and more.
- ❖ Easy Installation, use, and cleaning.
- ❖ Comes with an exclusive paddle for sliding food between the top and bottom plates, also ensuring safe opening and closing.
- ❖ It is possible to keep the panini press in the chamber, even when cooking other items without grill marks, by placing the basket on top of it.

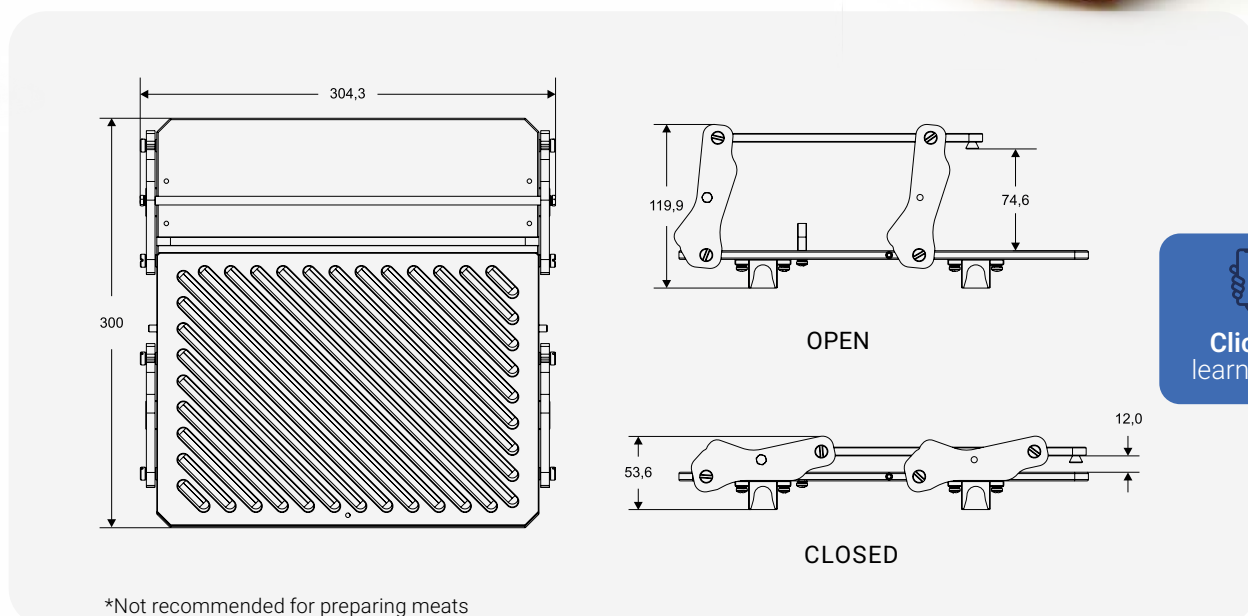

\*Not recommended for preparing meats





# Forza STi

## Stackable

Designed to ensure swift and exceptional deliveries, even during peak demands, the Forza STi proves to be an ideal solution for QSR (Quick Service Restaurant) establishments, as well as pizzerias, bakeries, hotels, kiosks, and convenience stores. The production of pizzas, flatbreads, cookies, and more becomes even better with the Forza STi, ensuring superior appearance, flavor, and textures. The combination of impinged air and infrared radiation allows for heating, browning, or toasting foods faster than traditional methods.



## Two Possibilities:

Forza STi  
Double Stacked

Forza STi



- ✔ Secures consistent results: through precise control, even heat distribution, rapid cooking, built-in sensors, and customization options, ensuring uniform and efficient cooking for reliable outcomes.
- ✔ Pizzas up to 16": fresh or par-baked dough, thin or thick crust.
- ✔ Stackable: can be stacked up to two ovens.
- ✔ The Forza STi double consists of two units stacked, which means each cavity requires independent power and each cavity has its own independent controls, allowing the temperature to be set individually, up to 626°F each.
- ✔ Elegant & Intuitive: stores unlimited recipes, with their own steps, settings, icons, or photos.
- ✔ User interface: full-color user-friendly touchscreen display. Drag and drop features.
- ✔ Multi-language system: Portuguese, English, Spanish, French, German, Polish, Russian, Mandarin, Greek.
- ✔ IOK: Create, edit, and organize groups, recipes, and complete menus directly on the oven or from your computer using Wi-Fi or USB Flash Drive and send them to all connected ovens.
- ✔ Ventless: no hoods needed.
- ✔ The removable catalytic converter allows operators to perform the cleaning without the need for a maintenance service call.
- ✔ Heat insulation: prevents the surrounding area from heating up and keeps the surface cool to the touch.

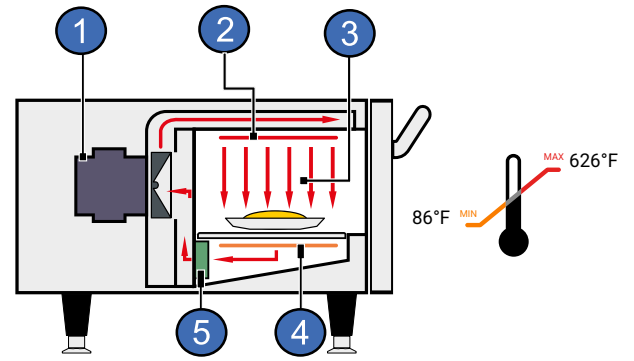

1. Blower Motor
2. Impingement Heater
3. Impinged Air
4. IR heater
5. Catalytic Converter

## Cook Times

Bruschettas	45 sec
Toasted Sub Sandwich	55 sec
Fresh Dough 40cm Pizza	3 min 30 sec
Half size sheet pan of cookies	10 min
Flatbread Pizza	2 min 15 sec

CERTIFIED  
**VENTLESS**  
WITH EASILY REMOVABLE  
CATALYTIC CONVERTER.

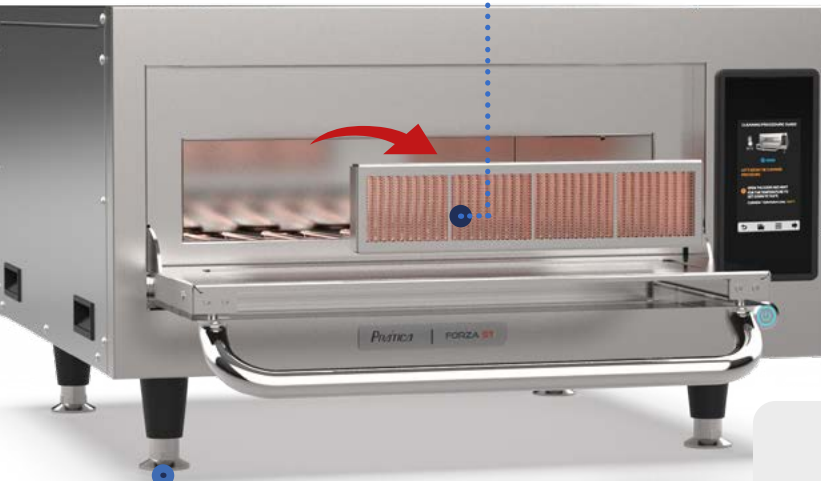

Optional adjustable feet

### Standard accessories



Click to learn more



1 year warranty for parts and labor, with the exception of naturally worn items.

## Forza STi

Region	Voltage (V)	Phases	Freq. (Hz)	Power (kW)	Circuit Breaker (A)	Cable	Socket	Product dimensions (Height x Width x Depth)	Boxed product dimensions (Height x Width x Depth)	Chamber dimensions (Height x Width x Depth)	Clearance (Left   Back   Right side)
Europe	230	Single	50	6.6	32	3x4	32A(2P+E)	Without feet 340 x 705 x 788 (mm)	640 x 845 x 955 (mm)	93 x 460 x 435 (mm)	0 / 0 / 25 (mm)
	380	Multi		6.2	16	5x2.5	16A(3P+N+E)	67kg			
	400	Multi		6.6	16	5x2.5	16A(3P+N+E)	67kg			
							With feet 442 x 705 x 788 (*)				

\*Prática recommends installing a type D circuit breaker. The electrical installation must comply with local regulations.

# FORZA STi



BACK TO MENU



**Small footprint**

13.3 x 27.7 x 31  
height x width x depth (")



**Ventless technology**

No need for hoods  
for operation



**Prepares 16" pizzas**

In 3 min 30 sec



**Temperatures  
up to 626°F**

Separate controls for  
temperature, and air  
impingement, bottom  
IR element of the chamber



**Double glass door  
& lighted cavity**

See cooking  
progress as the  
oven is working



**Energy  
efficient**

Low energy  
consumption



**Stainless steel**

Exterior & interior



**Each cavity has its own  
controls**

Can be used independently  
of the other

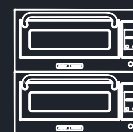

**Stackable**

Can be stacked up to  
two ovens high



# User-friendly Features

Available in all Prática's high-speed oven models.



## Removable Catalytic converter

Easy access and removal of the catalytic converter.



## Removable Air Filter

Designed for simple cleaning and maintenance.



BACK TO MENU

# Get it Ready in 2 taps!



Full color **user-friendly** touchscreen display



## **Elegant and Intuitive**

Our ovens store unlimited recipes, with their own steps, settings, icons, or photos.

## **Simple and Optimized**

A fresh spin on providing a great user interface while simplifying the basic oven operations for the end user.

# Features



Wi-Fi connectivity



**Multi-language system**  
(Portuguese, English, Spanish, French, German, Polish, Russian, Mandarin, Greek)

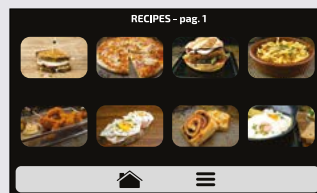

Photo library for recipes



Cleaning guide video with instructions



# Minimal Clearance

Advanced cooling design eliminates side vents and louvers allowing minimal to zero side clearance.

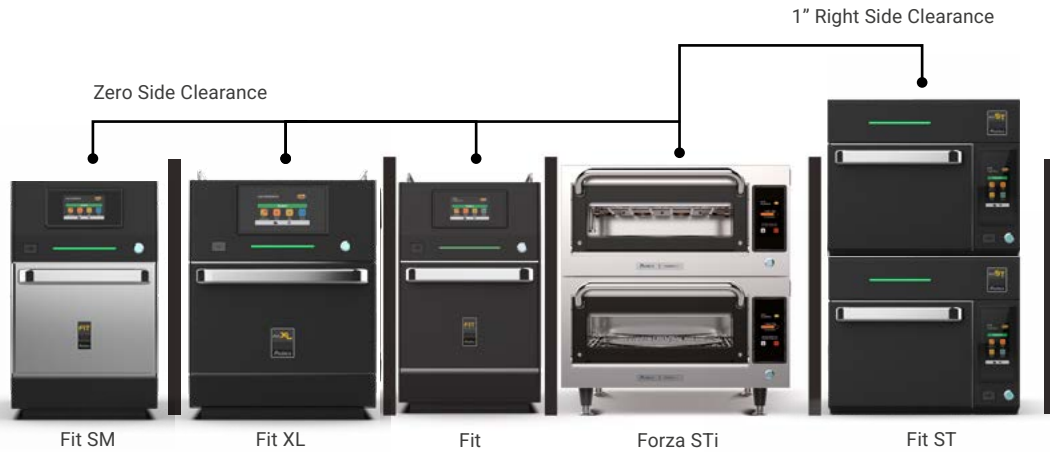

**i**  
Rear clearances are automatically set with factory-installed bumpers.

CERTIFIED

**VENTLESS**

No hoods needed for operation!

The Catalytic Converter turns grease-laden vapor into water, allowing the oven to operate with no need for exhaust hoods.\*

The Catalytic Converter is removable, allowing operators to perform the cleaning without the need for a maintenance service call.

All Prática's high-speed ovens have been tested and passed EPA202, allowing them to be certified as non-grease emitting appliances.

\*The high-speed ovens can't be used to cook foods classified as 'raw fatty proteins', such as bone-in, skin-on chicken, raw bacon, raw hamburger, etc. Failure to comply may damage the catalytic converter.



# PRÁTICA'S SMART HIGH-SPEED OVENS THE FUTURE OF COOKING

IOK is your all-in-one system for smarter kitchen management. It keeps your ovens aligned, your menus consistent, and your business ready to grow—whether you operate one store or many.



**MANAGE GROUPS AND RECIPES FROM YOUR COMPUTER**

Create, edit, remove, and distribute groups and recipes from the computer to all compatible ovens.



**CUSTOMIZE THE DISPLAY IMAGE OF RECIPES**

Illustrate recipes with real images of your products.



**RECEIVE SOFTWARE UPDATES**

Always count on system improvements for free, from small adjustments to major updates (such as a new interface or function, for example).

# PRÁTICA IOK USES YOUR WI-FI TO ALLOW FOR SEAMLESS MANAGEMENT OF EQUIPMENT ACROSS MULTIPLE LOCATIONS

Standardize your production and keep track of your ovens even when you are out of your kitchen.



All our touchscreen models come with Wi-Fi capabilities and can be connected to the IOK.



The IOK is 100% included with your oven purchase—no extra cost or monthly payments required.



With IOK, you can manage and monitor your equipment from anywhere, on any device—PC, Mac, mobile, or tablet.



Manage all your ovens and menus from one place—no need to handle them separately. Perfect for multi-oven locations and chains.



Create, edit, and organize groups, recipes, and complete menus directly on the oven or from your computer and send them to all connected ovens.



Customize the recipe icons with photos of your own dishes.



The IOK helps with the consistency of your recipe programming which allows your menu and recipes to be consistent from start to finish.



Update your ovens anytime, anywhere—Wi-Fi or USB.



Access the exclusive Cookbook with complete recipe suggestions created by Prática's Chefs.



Get customer support via chat using the IOK platform.



Click to  
learn more



BACK TO MENU

# Speed Ovens Accessories

## Panini Press

**Compatibility:** Fit Lite / Fit Express / Fit SM / Fit ST  
**Part Number:** 800552



## Speed Grill

**Compatibility:** Fit Express / FIT SM / FIT ST | Fit XL  
**Part Number:** 800526 | 800558

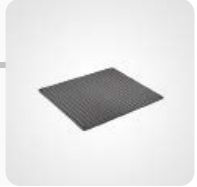

## Solid Basket

**Compatibility:** Fit Express / FIT SM / FIT ST | Fit XL  
**Part Number:** 800525 | 800561



## Pizza Screen

**Compatibility:** Forza STi  
**Part Number:** 760466



## Wave Perforated Basket

**Compatibility:** Fit Express / FIT SM / FIT ST / FIT XL  
**Part Number:** 800540



## Aluminum Paddle

**Compatibility:** Fit Express / FIT SM / FIT ST | Fit XL  
**Part Number:** 800507 | 800560



## Aluminum Paddle Forza STi

**Compatibility:** Forza STi  
**Part Number:** 800512



## Glass Cleaning Tool

**Compatibility:** Forza STi  
**Part Number:** 618213



## Easy Clean Liner

**Compatibility:** Fit Lite / Fit Express / FIT SM / FIT ST / FIT XL  
**Part Number:** 800591



# Part numbers listing

Part Number	Description	Model	Voltage	Freq.	Color
990114	Forza STi 230V 1 Phase 50/60Hz CE/RoHS	FORZA STI	230V Single	50/60HZ	-
990123	Fit Express Stainlees Steel 380V 3 Phases 50Hz CE/RoHS	FIT EXPRESS	380V Multi	50HZ	SILVER
990128	Fit Express Stainlees Steel 230V 1 Phase 50Hz CE/RoHS	FIT EXPRESS	230V Single	50HZ	SILVER
990131	Fit Express Stainlees Steel 400V 3 Phases 50Hz CE/RoHS	FIT EXPRESS	400V Multi	50HZ	SILVER
990138	Fit Express Black 230V 1 Phase 50Hz CE/RoHS	FIT EXPRESS	230V Single	50HZ	BLACK
990139	Fit Express Black 230V 400V 3 Phases 50Hz CE/RoHS	FIT EXPRESS	400V Multi	50HZ	BLACK
990140	Fit Express Black 380V 3 Phases CE/RoHS	FIT EXPRESS	380V Multi	50HZ	BLACK
990154	Fit Express Single Mag 13A Black 230V 1 Phase 50Hz CE/RoHS	FIT SM	230V Single	50HZ	BLACK
990156	Fit Express Single Mag 13A Stainlees Steel 230V 1 Phase 50Hz CE/RoHS	FIT SM	230V Single	50HZ	SILVER
990164	Fit ST Stainless Steel 380V 3 Phases 50Hz	FIT ST	380V Multi	50HZ	SILVER
990171	Fit Express Single Mag 13A Black 230V 1 Phase 50Hz CE/RoHS w/ plug CEE 7/7	FIT SM	230V Single	50HZ	BLACK
990173	Fit Express Single Mag 13A Stainlees Steel 230V 1 Phase 50Hz CE/RoHS w/ plug CEE 7/7	FIT SM	230V Single	50HZ	SILVER
990180	Fit XL Stainlees Steel 380V 3 Phases 50Hz CE/RoHS	FIT XL	380V Multi	50HZ	SILVER
990185	Fit ST Black 380V 3 Phases 50Hz CE/RoHS	FIT ST	380V Multi	50HZ	BLACK
990186	Fit ST Black 380V 3 Phases 50Hz	FIT ST	380V Multi	50HZ	SILVER
990187	Fit ST Black 380V 3 Phases 50Hz	FIT ST	380V Multi	50HZ	BLACK
990195	Fit XL Stainlees Steel 380V 3 Phases 50Hz CE/RoHS	FIT XL	380V Multi	50HZ	SILVER
990203	Fit XL Black 380V 3 Phases 50Hz CE/RoHS	FIT XL	380V Multi	50HZ	BLACK
990205	Fit XL Black 380V 3 Phases 50Hz CE/RoHS	FIT XL	380V Multi	50HZ	BLACK
990206	Fit XL Stainlees Steel 400V 3 Phases 50Hz	FIT XL	400V Multi	50HZ	SILVER
990207	Fit XL Black 400V 3 Phases 50Hz	FIT XL	400V Multi	50HZ	BLACK
990218	Fit ST Single Mag 13A Stainlees Steel 380V 3 Phases 50Hz	FIT ST SM	380V Multi	50HZ	SILVER
990219	Fit ST Single Mag 13A Black 380 3 Phases 50Hz CE/RoHS	FIT ST SM	380V Multi	50HZ	BLACK
990224	Fit ST Stainlees Steel 400V 3 Phases 50Hz	FIT ST	400V Multi	50HZ	SILVER
990225	Fit ST Black 400V 3 Phases 50Hz CE/RoHS	FIT ST	400V Multi	50HZ	BLACK
990256	Fit Lite Silver 230V 1 Phase 50Hz	FIT LITE	230V Single	50HZ	SILVER
990257	Fit Lite Silver 230V 1 Phase 50Hz w/ plug CEE 7/7	FIT LITE	230V Single	50HZ	SILVER
990258	Fit Lite Silver 13A 230V 1 Phase 50Hz	FIT LITE	230V Single	50HZ	SILVER
990245	Forza STi 380/400V 50/60Hz 3 Phases	FORZA STI	380/400 Multi	50/60HZ	-





# Prática and REPA: working together across Europe.

Prática is partnering with REPA in Europe to provide you with fast and easy spare parts shopping.

REPA manages Prática parts program with 100% original spares and the largest inventory of in-stock parts worldwide. REPA's warehouses ensure immediate availability of a vast selection of spare parts and consumables for all industries at your fingertips while collaborating with top-notch freight forwarders.

**Prática and REPA understand how crucial it is to keep your business running smoothly, and we're committed to supporting your operations by ensuring your equipment always performs at its best.**

REPA is the leading European spare parts distributor for foodservice equipment, coffee, vending machines and household appliances and is a trusted partner to equipment manufacturers. Since 2022 REPA is a division of Parts Town Unlimited, the global leader in high-tech distribution of mission-critical equipment replacement parts, related products and services for the foodservice, residential appliance and HVAC industries.

With state-of-the-art webshops, high stock availability, highly innovative logistics centers that assure the fastest delivery of spare parts in the industry, REPA provides every customer with the right part, at the right time, everywhere.

[www.repagroup.com](http://www.repagroup.com)

 **REPA**  
A Parts Town unlimited Company

BACK TO MENU





# The fastest way

to get your menu done!

**PRÁTICA**



BACK TO MENU



***PRÁTICA***  
***EUROPE***

[www.practicaeurope.com](http://www.practicaeurope.com)

[contact@practicaeurope.com](mailto:contact@practicaeurope.com)