



Version V8.3
FIBRE CEMENT FLOORBOARD



CEMBLOC.
DRYBLOC TG4
18, 20 & 22 mm

FLOORBOARD

GUIDE

Innovators of Fibre Cement Products

Fibre Cement Flooring - DryBloc® TG4

CEMBLOC.

DryBloc TG4 Description.

Technical Datasheet

CEMBLOC® DryBloc® TG4 is available in thicknesses 18mm and 22mm. The DryBloc® TG4 is an A1 fire rated solution thanks to its natural material, being fibre cement. CEMBLOC® DryBloc® TG4 is a T&G (tongue and groove) profile, reinforced cement fibre board, reinforced by natural minerals on both sides boasting an impressive loading capacities. These dry-fit screed replacement panels at only 18mm and 22mm thick offer minimal floor height and save on drying times when compared to traditional screeds. The DryBloc® is exceptionally unique as it offers an outstanding thermal conductivity value 0.216 W/mk when used in conjunction with underfloor heating systems. DryBloc®'s high density (1350kg /m³) provides excellent airborne sound performance through many types of separating floors. It is a high performing multipurpose building board that's designed purposely to provide fireproof, acoustic and waterproof protection, with very high dimensional stability which makes it a high performance alternative to Gypsum and Cement Particle for any construction type.

DryBloc® TG4 is superior flooring board with exceptional dimensional stability of (<0.19%) compared to alternatives such as chipboard, gypsum fibre and cement bonded particle board.

Advantages Of Use.

- Protects sub-construction system.
- Environment friendly.
- Does not contain any harmful substances to health.
- Asbestos free.
- A1 Fire Class
- Does not release toxic gas during the fire.
- Resistant to moisture and water.
- Resistant to the effects of sunlight.
- Resistant to seasonal changes.
- Easy assembly and modification procedures.
- Easy to cut with PCD circular saw
- Eliminates drying times of wet screed.
- Extends and protects the life of insulation material when used in heat and sound insulation systems.
- Extremely high dimensional stability (<0.19%) when compared to chipboard, gypsum and cement particle.
- It is odorless and does not release toxic gas.
- Resistant to biological and chemical wastes.
- Insect-proof, non-putrescible, no molding.
- Offers different solutions in all areas of building projects.
- Can be used with insulating material of any desired thickness.
- Can be used in fine details with smooth cutting surfaces.
- Very high impact resistance compared to gypsum based boards.

Standard Dimensions.

Thickness

18mm, 22mm

Dimensions

1200 x 600m



Technical Specifications.

Water Impermeability	Pass - No formation of drops of water was found after being tested.
Thermal Insulation	0.133 m ² K/w (20mm)
Thermal Conductivity	0.216 W/mK
Bending Strength (Modulus Of Rupture as tested on 18mm variant)	MOR Average 20,31 MPa, Equilibrium condition: MOR average: 21,95 MPa, Wet condition: MOR average: 20,31 MPa,
Recommended Span	<600mm (22mm) <450mm (18mm)
Water Absorption	<29%
Wet Expansion Rate	0.19%
Heating Shrinkage Rate	0.18%
Density	1350 kg/m ³ (± 50kg)
Fire Propagation	Class "0" (<2) (BS 476-Part 6)
Fire Resistance	Class 1 (BS 476-Part 7)
Combustibility	Non-Combustible
Reaction To Fire	A1
Distributed Loading Capacity (Internal use)	As chart below

Joist Spacing (ctrs) Thickness	CL	CL
	DryBloc® TG4 18/22 Recommended for spans up to 450mm	DryBloc® TG4 22 Recommended for spans up to 600mm
18mm	3.50 kN	Not suitable for use
	356.9 kg	Not suitable for use
22mm	4.70 kN	2.70 kN
	479.26 kg	275.32 kg

- Concentrated load is applied over an area of 500mm x 500mm
- Allowable maximum deflection is limited to l/250 of joist spacing.
- CL, Continuous load.
- For spans 450mm and above we recommend DryBloc® TG4/22 and for spans below 450mm, DryBloc® TG4/18 subject to expected loading



Reference To Acoustic Ratings.

Steel Joist Floor
DnT,w + Ctr

54dB

LnT,W (with 4.5mm resilient layer)

57dB

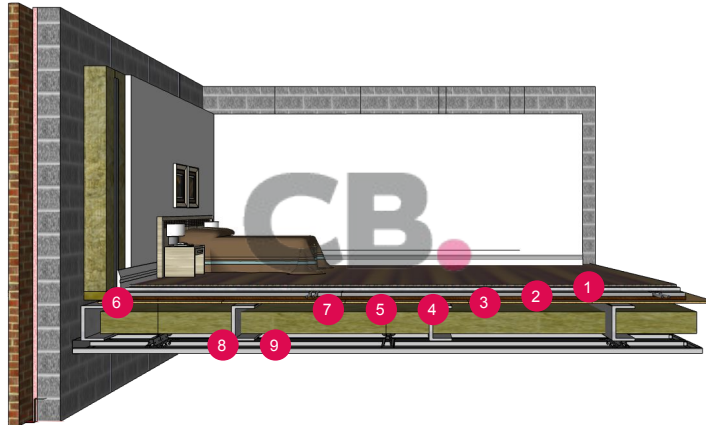

1. Sheet vinyl or LVT flooring
2. Adhesive layer (self levelling)
3. DryBloc® TG4 18mm
4. Routed UFH Insulation
5. 4.5mm resilient layer
6. L Shaped Flanking Strip
7. Minimum 25mm timber floor joists
8. Minimum 225mm steel floor joists
9. Heavy duty resilient bars
10. 2 x 15mm acoustic plasterboard

Profiled Metal Decking
DnT,w + Ctr

53dB

LnT,W (with 4.5mm resilient layer)

49dB

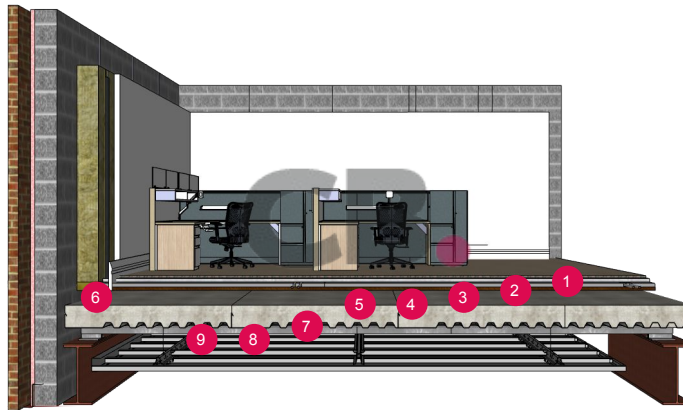

1. Engineered wooden flooring
2. Decoupling layer or adhesive
3. DryBloc® TG4 18mm
4. Routed UFH insulation
5. 4.5mm resilient layer
6. L Shaped Flanking Strip
7. 130mm concrete and profiled metal deck.
8. MF ceiling (min 100mm void)
9. 1 x 9.5mm acoustic plasterboard

Timber Joist Floor
DnT,w + Ctr

51dB

LnT,W (with 4.5mm resilient layer)

58dB

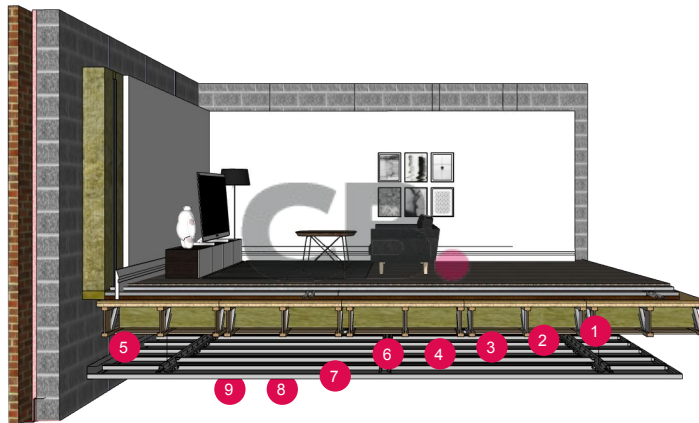

1. Carpet and Underlay
2. DryBloc® TG4 18mm
3. Routed UFH Insulation
4. 4.5mm resilient layer
5. L Shaped Flanking Strip
6. Chipboard Structural Deck
7. Minimum 25mm timber floor joists
8. Heavy duty resilient bars
9. 2 x 15mm acoustic plasterboard

Concrete Insitu Floor
DnT,w + Ctr

53dB

LnT,W (with 4.5mm resilient layer)

49dB

ΔL_w (with 4.5mm resilient layer)

20dB

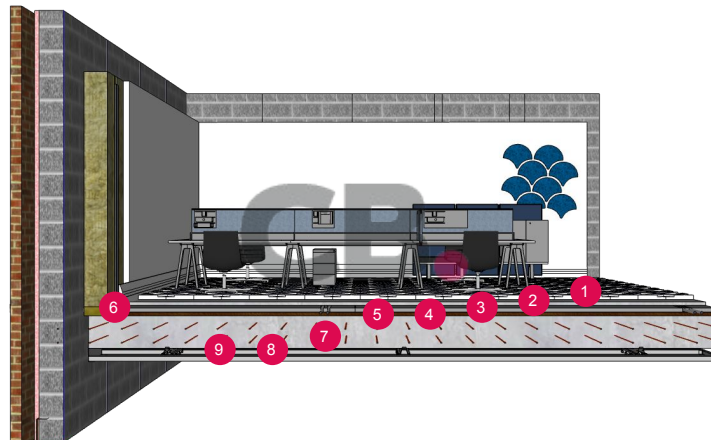

1. Ceramic Tiles
2. Electric UFH cables set in tile adhesive
3. DryBloc® TG4 18mm
4. Routed UFH insulation
5. 4.5mm resilient layer
6. L Shaped Flanking Strip
7. 200mm Reinforced insitu concrete slab
8. MF ceiling (min 100mm void)
9. 1 x 9.5mm acoustic plasterboard

Tongue and Groove Profile.

Drawing (mm)

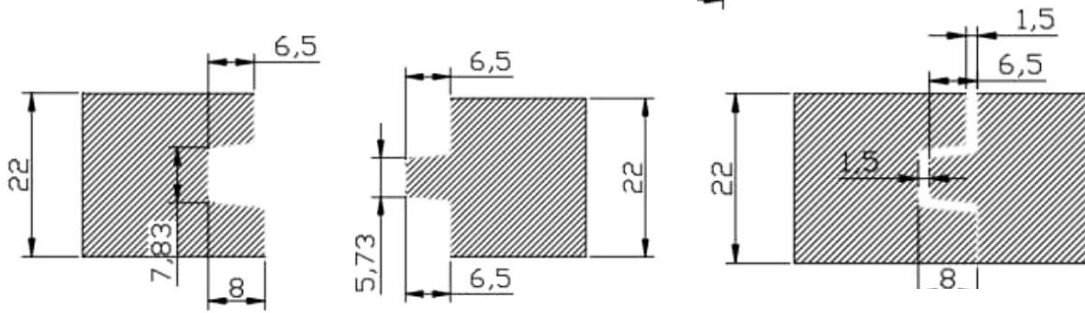

Can be used in conjunction with routed insulation for (UFH) Under Floor Heating applications, 0.216 W/mk.. Suited to both a timber joist and steel joisted floor. Can also be used as part of a build up onto a Metsec style decking. Span joists at 400/ 600mm (DryBloc® TG4 18mm/22mm)

Wet screed replacement.
 Suitable for beam and block constructions.
 Access flooring.
 Raised terrace.
 Mezzanine flooring (DryBloc® TG4 38mm)
 Replace traditional style timber floorboards.

References.

A: Staggered Pattern (as shown below)

B: Fixing Locations (as shown in red circles below)

If the boards join between joists, we recommend installing noggins for added support.

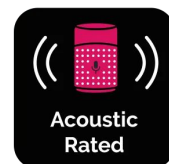
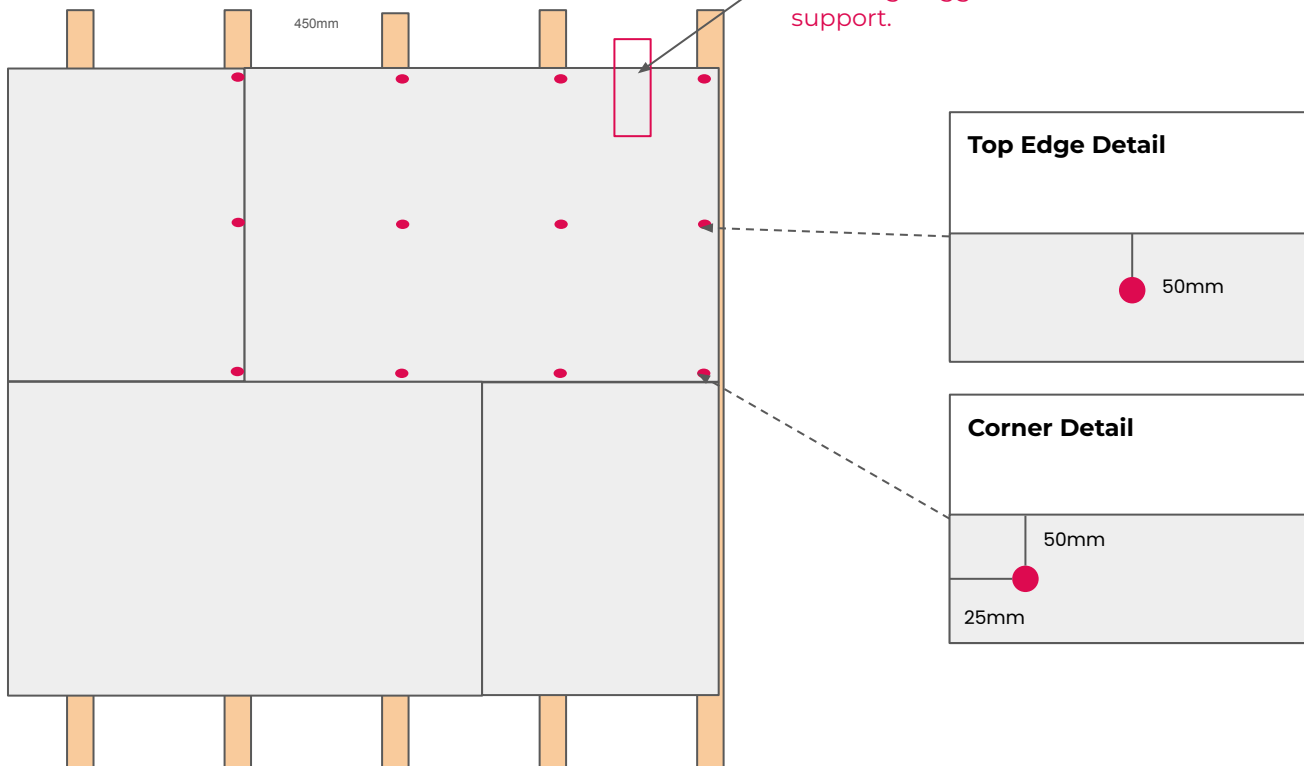

System Configuration:

- Board joints: Bond every tongue & groove with CemBond Max Strength sealant/adhesive
- Perimeter isolation: Install PhonoStrip cork-polymer flanking band continuously at all perimeters, thresholds, and abutments (maintains 6–10 mm movement/isolation gap).
- Mechanical fixings: CEMBLOC® FCB 42mm screws (9 per board)
- Primer: CEMBLOC® SBR Primer is advised wherever a new bonded layer is applied. Follow the CEMBLOC® SBR Primer datasheet for coverage, dilution, number of coats, and drying/overcoat times. This is advised due to the nature of fibre cement being porous, without a primed layer, the board will soak up any water / moisture potentially affecting any adhesive / bonded layer

Structural Limits

- Direct to joists at up to <600mm (22mm) and <450mm (18mm) subject to loading (refer to distributed Loading Capacity table in page 3) - recommended to use 22mm for any joist centre over 400mm for an optimised solution. Ensure joists are level and adequately stiff, control twist with noggins as required
- Minimum pad/washer: recommend a $\geq 50 \times 50$ mm washers/pads for anything approaching the 3–5 kN concentrated loads to reduce the localised stress
- Avoid placing heavy point loads mid-panel without plates — redistribute heavy furniture or equipment onto multiple joists or plates to span across the joists to evenly distribute the load accordingly.

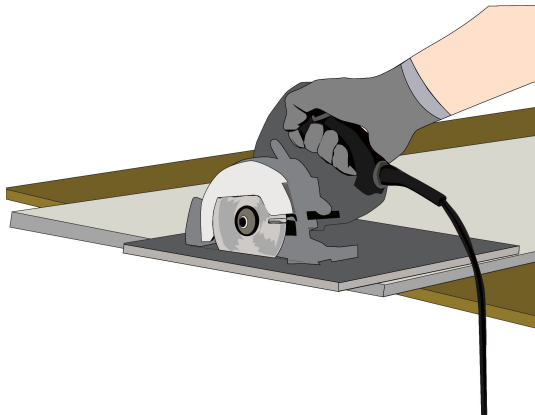

Step 1. Cut boards to size.

Cut CEMBLOC® DryBloc® TG4 using a circular saw fixed with a suitable vacuum extractor and a Polycrystalline Diamond (PCD) Saw blade to avoid excessive wear on other blade types. This method will cut boards easily at the same time mitigating dust. Our CEMBLOC® boards can be cut with either a fine tooth hand saw or power saw, whilst ensuring suitable dust control measures are taken (eg localised extraction where possible, protective safety glasses, gloves and respiratory masks as per MSDS) and observing all necessary health and safety regulations. Boards should be fixed with the board text facing upwards (smooth texture).

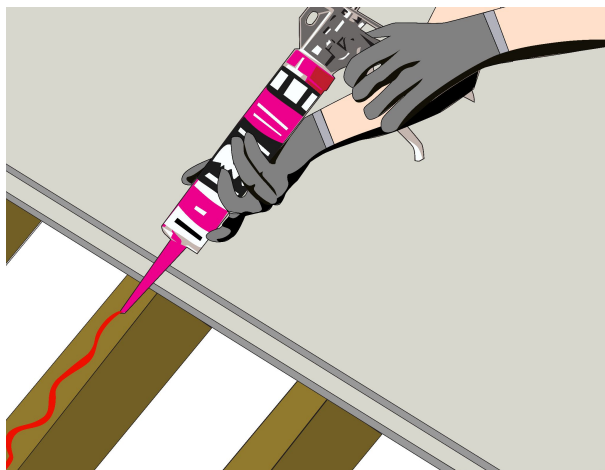

Step 2. Bond boards to joists.

CEMBLOC® DryBloc® TG4 can be fixed to timber or steel joists installed at a maximum of 600mm centres (for 22mm only), ideally at 450mm centres. To achieve an acceptable finish, it is important that floor joists are level prior to laying.

Apply a 3-5mm bead of high strength Cembond MAX Strength Cement Fibre Adhesive to the joist, then position the first board and so on.

Step 2 continued - *Installation note to be aware of.*

If when laying the boards down and a raised lip appears whilst butting one board to the next, please follow the below guidelines.

1. * One potential solution to address this concern is to flip the problematic board so that the rougher side is facing upwards, positioning it next to an upward-facing smooth surface. By doing this, you should be able to effectively resolve this issue directly on site.
2. * Another way to address any unevenness, we would recommend the use of a higher mass adhesive to bond the finishing floor to the DryBloc, ensuring a more secure and stable result.

Installation Guidelines for DryBloc TG4.



Step 3. Mechanically fix with screws (Skip if using above UFH)

Secure with a minimum of 6Nr CEMBLOC® FCB Screws 4.2mm x 42mm self-drilling and self-countersinking. (up to 9Nr for uncut boards) REF:B self drilling point and a countersunk head screws, placed a minimum of 12mm from the square edge and 5mm from the side of the joist. Ensure screws are placed a minimum distance of 25mm from the tongue and groove edge.

Make sure you have the boards smooth side up. *see step 2, note 1 & 2 if complications occur.

Step 4. Apply adhesive to grooves.

Lay CEMBLOC® DryBloc® TG4 in a staggered pattern (similar to a brick pattern REF:A) Our Tongue and groove joints do not need to end on a joist but all square edges should be fully supported. Secure boards together by applying Cembond MS - MAX Strength Cement Fibre Adhesive 310m along the length of the board's groove and before inserting the tongue of the next board.

Priming may be required depending on the chosen floor finish. As fibre cement is a porous material, the board can absorb moisture if left unprimed.

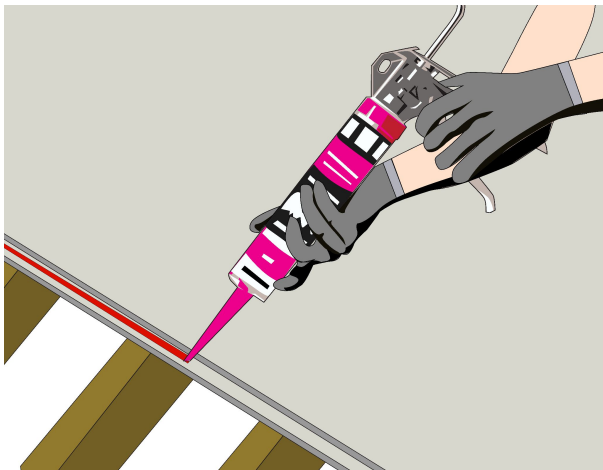

Tongue and grooved boards: Are usually laid with their longer edges perpendicular to the span of the joists. Joints between the shorter edges are to be supported with a noggin along its centreline. Tongue and grooved joints between boards should be glued using CemBond Max Strength. This allows the boards to be fully supported by the joists along their entire length, enhancing the floor's strength and stability.

If there is a cumulative build up across multiple joists, with joist spacing.

* A potential solution would be to slightly adjust the layout of the boards to stagger the joints, which might help to alleviate the cumulative gap issue.

* Additionally, you could consider trimming a small section off the first board, which would realign the rest of the boards with the joists for better coverage.

Ensure to allow an expansion gap around the perimeter of the floor

Material Safety (MSDS).**Health And Safety Best Practises.**

Dust: When processing the boards, for example, cutting, drilling, sanding etc, these will generate dust. As a result, attention should be paid to the dust particles generated and measures put in place to minimise their effect. Please process the boards in a well ventilated area with the use of localised extraction to avoid dust inhalation.

Skin Contact:

- **Acute Effect:** The dust from these products may cause irritation of the skin due to friction but is not absorbed through the skin.
- **Precautions:** Direct contact with dust and debris should be avoided by wearing full body covering overalls. .
- **Measures taken if effect experienced:** Wash thoroughly with soap and water.

Ingestion:

- **Effect:** When processing, the dust may affect food and beverages, indigestion of the dust may result in abdominal discomfort.
- **Precautions:** Do not attempt to eat the board, put the board near the face and avoid touching your face and mouth when previously dealt with the board.
- **Measures taken if effect experienced:** Ingestion is unlikely due to product size. However should this occur, seek medical attention immediately.

Inhaled:

- **Effect:** The dust from processing may cause irritation of nose, throat, lung and cause coughing and sneezing via breath.
- **Precautions:** During dry cutting ,drilling, routing , sanding and any continuous handling where dust is generated, used an approved particulate dust mask .
- **Measures taken if effect experienced:** Go into a open area with plenty of air circulation outdoors and drink plenty of water, until acute effects have gone.

If any acute effects persist, seek medical attention immediately.

Handling Requirements.

Minimise the dust generation at the workplace. When there is cutting, sawing, sanding or grinding during the installation and handling of this product, it should be carried out at well ventilated area (e.g. outdoor, open-area). Work area should be cleaned regularly by wet sweeping or vacuuming.

Cembloc panels are stacked on timber pallets. The boards must be stored in a ventilated and dry environment on a flat, level surface protected from contamination. To avoid excessive flexing of the boards, long edges must be supported when lifting and handling.

Storage:

Store in a dry well ventilated area. The boards should be protected from excessive humidity and temperature changes, such as rain, sun, wind and moisture. The boards must always be stored on flat level surface.

Contact us.

Let's talk about your project.

We are proud of our reputation for excellent service.

Whether you require, part or full load deliveries, our team will make sure we do everything possible to help you and your project, as together we can build better.



England, UK Sales Office.

Middlewich, Cheshire.

Mainline: +44 (0)208 050 5302

Enquiries: support@cembloc.com

Finance: accounts@cembloc.com



Texas, US Sales Office.

Sunridge Business Park, 101 Sunridge Blvd

Wilmer TX75172

Enquiries: support@cembloc.com



Dubai, UAE Sales Office.

The European Business Centre,

2534+G2J - Dubai Investments Park

Enquiries: support@cembloc.com



Paris, France Sales Office.

COMING SOON



Sydney, Australia Sales Office.

Hollinsworth Road, Marsden Park,

NSW 2765

Enquiries: support@cembloc.com