



立足台灣、胸懷亞洲、放眼天下

Footing At Taiwan, Broad Minded of Asia & Glance on World



**主上工業股份有限公司**

PRAISE PRECISION IND. CO., LTD.

台灣台中市東區天乙街66號

66, TAN YE ST., EAST DIST., TAICHUNG, TAIWAN

TEL:886-4-22810909(代表號 REP.)

FAX:886-4-22810923

<http://www.7-hero.com.tw>

E-mail:seven.hero@msa.hinet.net

Skype:praiskype

Skype:praiskype01

版權所有 翻印必究 2014.6

**7-HERO®**

七豪牌

**主上工業股份有限公司**

PRAISE PRECISION IND. CO., LTD.

**切削刀具 CUTTING TOOLS**





七豪~七好

七豪七好七樣好

品質一流絕對好

精度準確實在好

韌性強度真正好

耐磨耐溫壽命好

修邊倒角美觀好

售後服務保證好



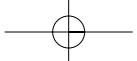

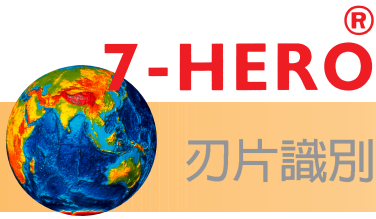
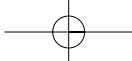

# 刀片識別系統/Turning Insert Identification System

<b>A</b>	<b>B</b>	<b>C</b>
<b>D</b>	<b>E</b>	<b>F</b>
<b>G</b>	<b>N</b>	<b>P</b>

② 離隙角 Relief angle

<b>H</b>	<b>O</b>	<b>P</b>	<b>R</b>	<b>S</b>
<b>T</b>	<b>C</b>	<b>D</b>	<b>E</b>	<b>M</b>
<b>V</b>	<b>L</b>	<b>A</b>	<b>B</b>	<b>K</b>

① 刀片形狀 Insert shape

tolerances  
IC: theoretical diameter of the insert inscribed circle  
T: thickness  
B: see figure below

tolerance class	tolerance on "IC"		tolerance on "B"		tolerance on "T"	
	in	mm	in	mm	in	mm
C	±0.010	±0.025	±0.0005	±0.013	±0.001	±0.025
H	±0.005	±0.013	±0.0005	±0.013	±0.001	±0.025
E	±0.010	±0.025	±0.0010	±0.025	±0.001	±0.025
G	±0.010	±0.025	±0.0010	±0.025	±0.005	±0.13
M	see tables at right		see tables at right		±0.005	±0.13
U	see tables at right		see tables at right		±0.005	±0.13

③ 精度記號 Tolerance

<b>N</b>		<b>T</b>	
<b>R</b>		<b>Q</b>	
<b>F</b>		<b>U</b>	
<b>A</b>		<b>B</b>	
<b>M</b>		<b>H</b>	
<b>G</b>		<b>C</b>	
<b>W</b>		<b>J</b>	

④ 溝孔記號 Insert type

inch	<b>C</b>	<b>N</b>	<b>M</b>	<b>G</b>	—	<b>4</b>	<b>3</b>	<b>2</b>			
(metric)	<b>C</b>	<b>N</b>	<b>M</b>	<b>G</b>		<b>12</b>	<b>04</b>	<b>08</b>			
position	①	②	③	④		⑤	⑥	⑦	⑧	⑨	⑩

切刃長和內接圓記號 | 5 | 尺寸 Size

inch	IC		metric cutting edge length								
	in	mm	C	D	R	S	T	V	W		
1.2 (5)	5/22	3.97	—	04	03	03	06	—	—		
1.5 (6)	3/16	4.76	04	05	04	04	08	08	—		
1.8 (7)	7/22	5.56	05	06	05	05	09	09	03		
—	0.236	6.00	—	—	06	—	—	—	—		
2	1/4	6.35	06	07	06	06	11	11	04		
2.5	5/16	7.94	08	09	07	07	13	13	05		
—	0.315	8.00	—	—	08	—	—	—	—		
3	3/8	9.52	09	11	09	09	16	16	06		
—	0.394	10.00	—	—	10	—	—	—	—		
3.5	1/6	11.11	11	13	11	11	19	19	07		
—	0.472	12.00	—	—	12	—	—	—	—		
4	1/2	12.70	12	15	12	12	22	22	08		
4.5	9/16	14.29	14	17	14	14	24	24	09		
5	5/8	15.88	16	19	15	15	27	27	10		
—	0.630	16.00	—	—	16	—	—	—	—		
5.5	11/16	17.46	17	21	17	17	30	30	11		
6	3/4	19.05	19	23	19	19	33	33	13		
—	0.787	20.00	—	—	20	—	—	—	—		
7	7/8	22.22	22	27	22	22	38	38	15		
—	0.984	25.00	—	—	25	—	—	—	—		
8	1	25.40	25	31	25	25	44	44	17		
10	1-1/4	31.75	32	38	31	31	54	54	21		
—	1.260	32.00	—	—	32	—	—	—	—		

⑥ 厚度 Thickness

thickness		symbol	
in	mm	inch	metric
1/32	0.79	0.5 (1)	—
1/16	1.59	1 (2)	01
5/64	1.98	1.2	T1
3/32	2.38	1.5 (3)	02
1/8	3.18	2	03
5/22	3.97	2.5	T3
3/16	4.76	3	04
7/32	5.56	3.5	05
1/4	6.35	4	06
5/16	7.94	5	07
3/8	9.52	6	09
7/16	11.11	7	11
1/2	12.70	8	12

NOTE: Inch sizes in parenthesis for "alternate sizes" D or E (under 1/4 inch IC).

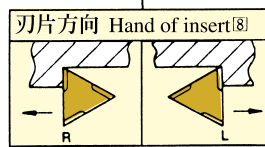

⑦ 刀尖R記號 Corner radius

corner radius		symbol	
in	mm	inch	metric
.004	0.1	0	01
.008	0.2	0.5	02
1/64	0.4	1	04
1/32	0.8	2	08
3/64	1.2	3	12
1/16	1.6	4	16
5/64	2.0	5	20
3/32	2.4	6	24
7/64	2.8	7	28
1/8	3.2	8	32
round insert (inch)	—	—	00
round insert (metric)	—	—	M0

⑨ & ⑩ 切邊狀況及切屑處理  
Cutting edge condition & chip control

- T-負向 Negative land
- K-輕切削 Light feed chip control
- 雙向 Kiniooc 刀片
- M-重切削進刀 Heavy feed chip control
- 深化 Floor keniooc
- N-窄域 Narrow land
- 刀片切屑為單邊 Insert(w) chip control on one side
- W-重切削 Heavy duty chip control
- 單向寬域 Wide land keniooc insert one side
- J-拋光至 4 微米吋 AA (推進刀面)
- UF-特別精細加工 Ultra-fine finishing

NOTE: Inch sizes in parenthesis for "alternate sizes" D or E (under 1/4 inch IC).

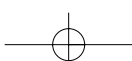

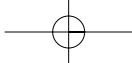

# 內徑車刀架識別系統/Boring Bar Identification System

**S-steel(鋼)**  
**A-steel(w)thru coolant**  
 (刀柄中心出水)  
**D-Devibrator(防震刀架)**  
**C-Carbide(鎢鋼)**  
**E-Carbide(w)thru coolant**  
 (鎢鋼刀柄中心出水)  
**H-Interchangeable head**  
 (可更換刀頭)  
**R-Rotating head(迴轉刀頭)**  
 Boring bar or head type(刀架或刀頭型式)

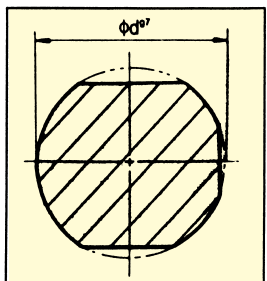

N	0°	
P	11°	
C	7°	
B	5°	

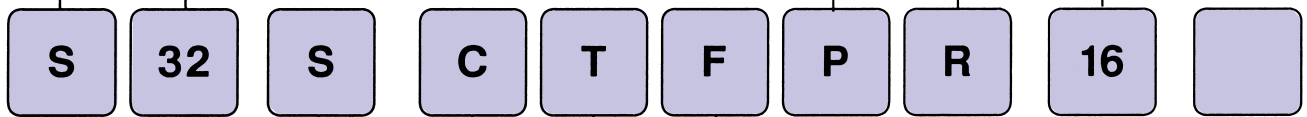
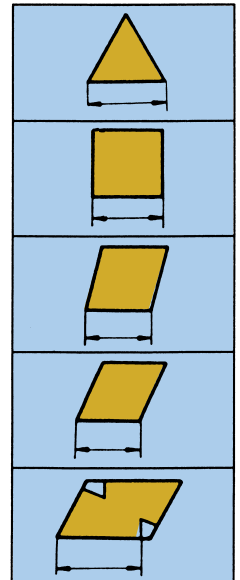
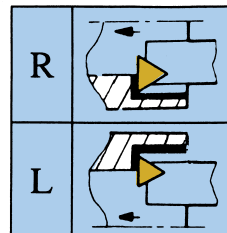

柄長 Shank length $l_1$ (mm)	
K	125
M	150
Q	180
R	200
S	250
T	300
U	350
V	400
W	450
Y	500
X	Special

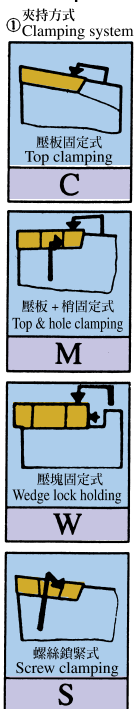

T	60°	
S	90°	
C	80°	
D	55°	
K	55°	
W	80°	

L	95°	
U	93°	
F	90°	
K	75°	
Z	93°	
Q	108°	

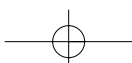

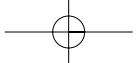

# 外徑車刀架識別系統/Turning Tool Holders Identification System

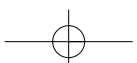
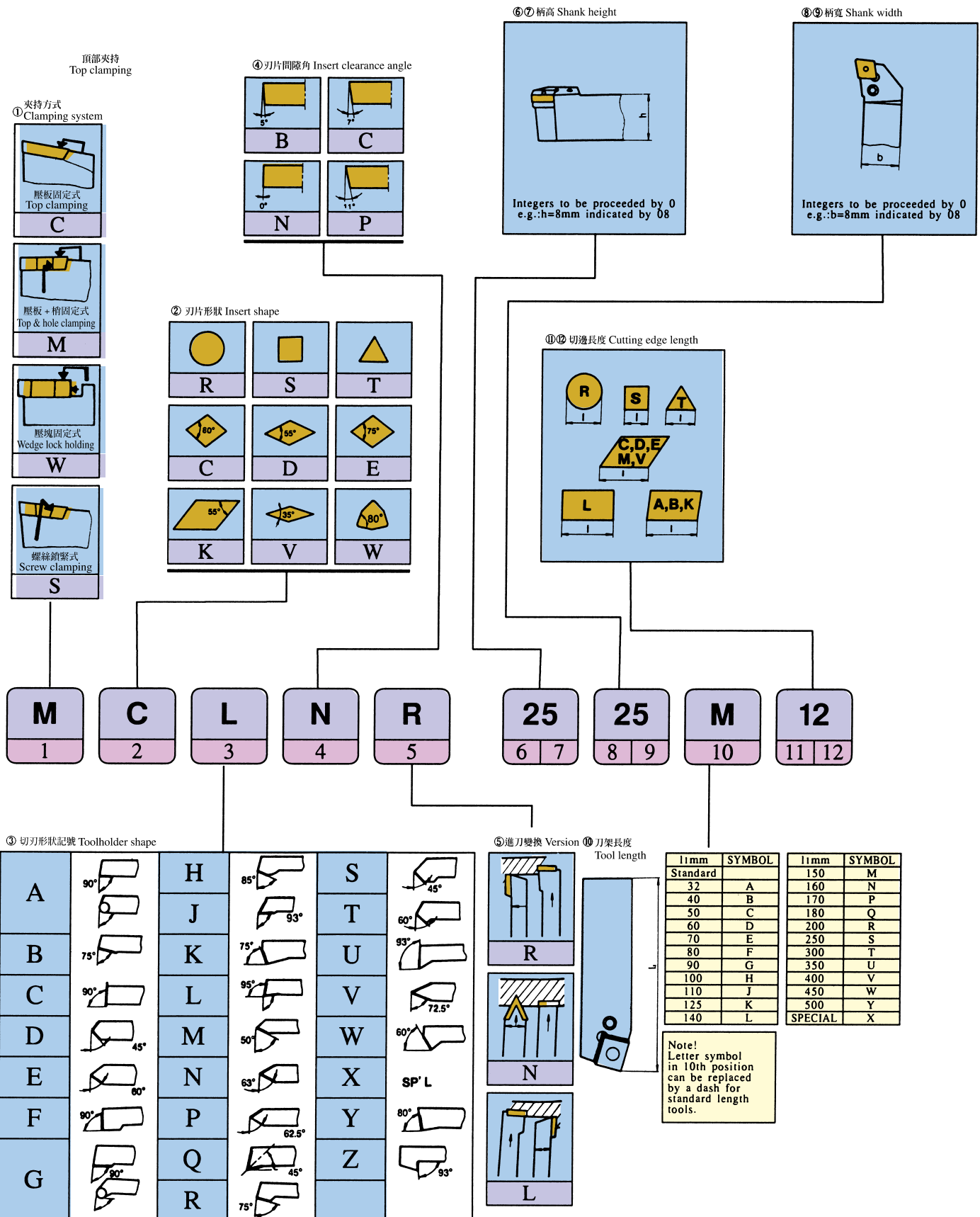

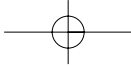

# 唯有正確選擇適當刀具 足以解決全部切削問題 亦唯有主上適堪此大任

**YOUR COMPLETE SOLUTION BY  
CHOOSING THE RIGHT CUTTING TOOL  
TO SOLVE HARD JOB AND ONLY PRAISE  
YOU CAN TRUSTED**

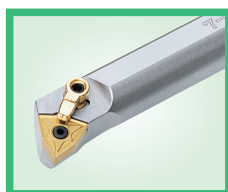

內徑車刀架系列/Boring Bar Series  
(合金鋼柄/Alloy-Steel Shank) .....A001~A011

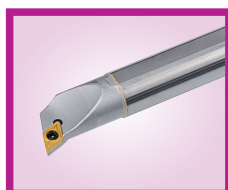

內徑車刀架系列/Boring Bar Series  
(超微粒碳化鎢鋼柄/Micro Grain Tungsten Carbide Steel Shank) .....B001~B005

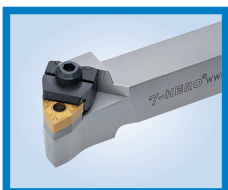

外徑車刀架系列  
Tool Holders Series .....C001~C013

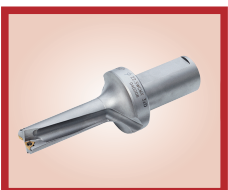



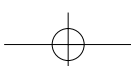

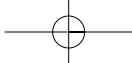



捨棄式快速鑽頭/Rapid Drills(W)  
Throw-Away Insert .....D001~D007

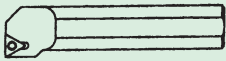

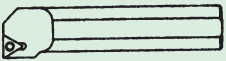
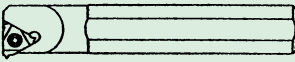
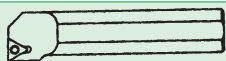
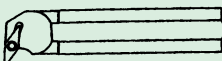
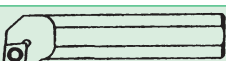

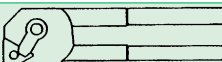

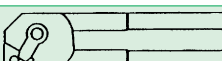
# 索引 INDEX

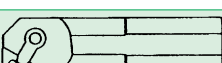
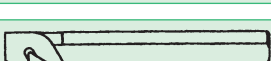
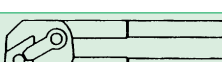
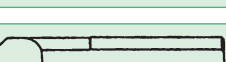
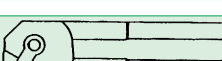
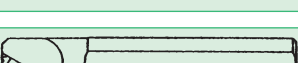
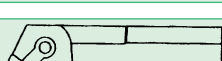
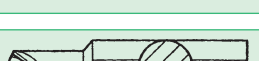
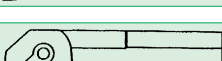
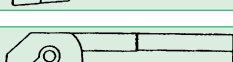
## 內徑車刀架系列/Boring Bar Series (合金鋼柄/Alloy-Steel Shank)

	<b>STFC</b> A001		<b>GIVR</b> A007
	<b>STUC</b> A002		<b>SINR</b> A007
	<b>STUP</b> A002		<b>SVUC</b> A008
	<b>SCLC</b> A003		<b>SVJC</b> A008
	<b>SCLP</b> A003		<b>MTFN</b> A009
	<b>SDUC</b> A004		<b>MTUN</b> A009
	<b>SDQC</b> A004		<b>MTUN-A</b> A009
	<b>SDZC</b> A005		<b>MDUN</b> A010
	<b>STWC</b> A005		<b>CTFP</b> A010
	<b>SNR</b> A006		<b>MWLN</b> A011
	<b>SWUB</b> A006		<b>MCLN</b> A011
			<b>MCKN</b> A011

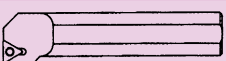
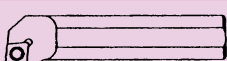
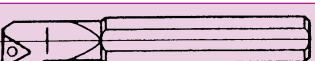
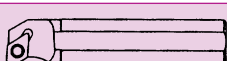
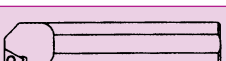
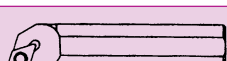

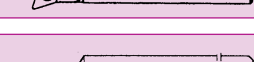
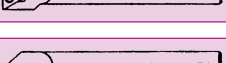
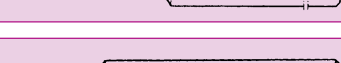

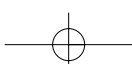

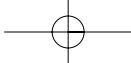

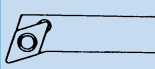
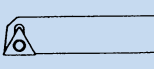
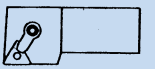
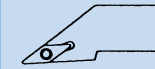

## 內徑車刀架系列/Boring Bar Series (超微粒碳化鎢鋼柄/Micro Grain Tungsten Carbide Steel Shank)

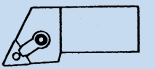
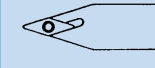
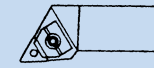
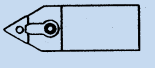
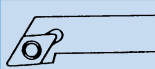
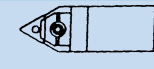
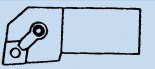
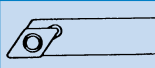
	<b>STFC</b> B001		<b>SCLP</b> B003
	<b>STUB</b> B001		<b>SDUC</b> B004
	<b>STUP</b> B002		<b>SDQC</b> B004
	<b>STUC</b> B002		<b>SCLC</b> B005
	<b>SCLC</b> B003		<b>SWUB</b> B005

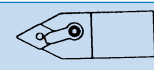
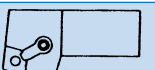
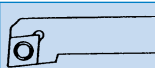
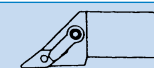
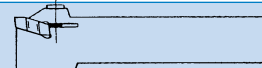
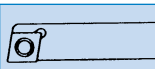
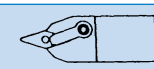
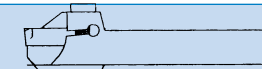
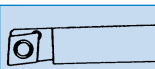
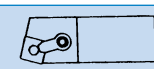
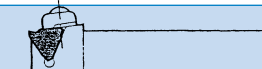

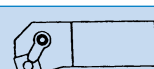
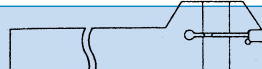

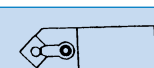
## 外徑車刀架系列 Tool Holders Series

 <b>SDQC C001</b>	 <b>STAC C004</b>	 <b>MTGN C008</b>
 <b>SVJC C001</b>	 <b>WTXN C005</b>	 <b>MTJN C008</b>
 <b>SVVCN C001</b>	 <b>WTJN C005</b>	 <b>MTEN C009</b>
 <b>SDJC C002</b>	 <b>WTEN C005</b>	 <b>MCLN C009</b>
 <b>SDAC C002</b>	 <b>MDJN C006</b>	 <b>MCKN C010</b>
 <b>SDNCN C002</b>	 <b>MDNN C006</b>	 <b>MCRN C010</b>
 <b>SCLC C003</b>	 <b>MVJN C006</b>	 <b>GHGR C011</b>
 <b>SCAC C003</b>	 <b>MVVN C007</b>	 <b>DGTR C012</b>
 <b>SCLC-N C003</b>	 <b>MSBN C007</b>	 <b>KGBR C014</b>
 <b>MWLN C004</b>	 <b>MSKN C007</b>	 <b>KTKHR C013</b>
 <b>WWLNC004</b>	 <b>MSDN C008</b>	 <b>SER C014</b>

## 捨棄式快速鑽頭 Rapid Drills(W)Throw-Away Insert

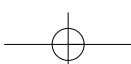
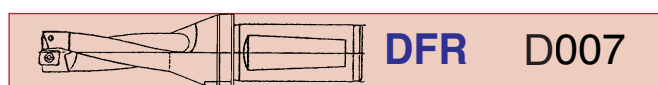
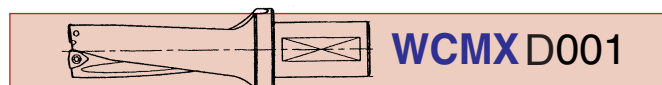

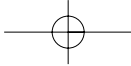



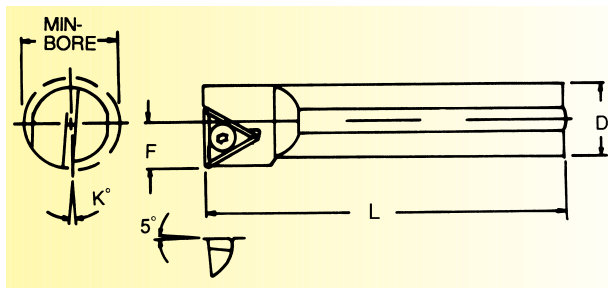
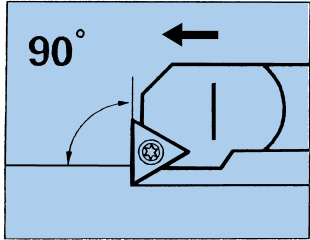

# 內徑車刀架系列/Boring Bar Series (合金鋼柄/Alloy-Steel Shank)

## STFC



訂購編號 Style No.	產品型號 Model No.	部位尺寸 Dimensions(mm)					刀片 Insert	零件 Parts		訂價 (NT\$)
		D	F	L	B	K°				
	S08H-STFCR/L09	8	6	100	12	12°	TCMM 0902□□		T-7	
	S10K-STFCR/L09	10	7	125	14	15°				
	S12M-STFCR/L09	12	9	150	16	10°				
	S12M-STFCR/L11	12	9	150	16	10°	TCMM 1102□□		T-8	
	S16Q-STFCR/L11	16	11	180	20	6°				
	S20R-STFCR/L11	20	13	200	25	3°				

A

- 01
- 02
- 03
- 04
- 05
- 06
- 07
- 08
- 09
- 10
- 11

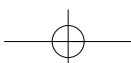

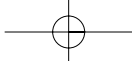

# 內徑車刀架系列/Boring Bar Series (合金鋼柄/Alloy-Steel Shank)

## STUC/STUP

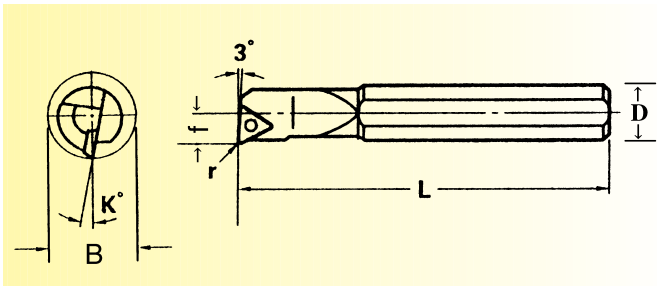
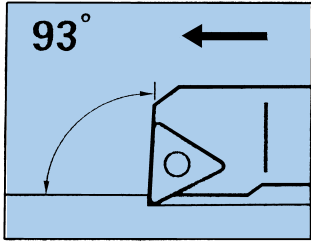

訂購編號 Style No.	產品型號 Model No.	部位尺寸 Dimensions(mm)					刀片 Insert	零件 Parts		訂價 (NT\$)			
		D	F	L	B	K°							
	S08H-STUCR/L09	8	6	100	10	12°	TCMM 0902□□	CS22	T-7				
	S10K-STUCR/L09	10	7	125	12	15°							
	S10K-STUCR/L11	10	7	125	12	15°	TCMM 1102□□	CS25	T-8				
	S12M-STUCR/L11	12	9	150	14	10°							
	S14N-STUCR/L11	14	8	160	16	8°							
	S16Q-STUCR/L11	16	11	180	20	6°							
	S20R-STUCR/L11	20	13	200	25	3°							
	S25R-STUCR/L16	25	14	200	28	3°				TCMM16T3	CS35	T-15	
	S0807H-STUBR06-08	8	4	100		12°	TBGT0601	CS20	T-6				
	S08H-STUPR/L08	8	5	100	10	10°	TPGT0802	CS22	T-7				
	S10K-STUPR09-12	10	6	125	12	8°	TPMT 0902□□	CS25	T-8				
	S12M-STUPR/L09	12	8	150	16	5°							
	S12M-STUPR09-14	12	7	150	14								
	S10K-STUPR/L11	10	6	125	12	8°	TPGT 1103□□	CS30	T-10				
	S12M-STUPR/L11	12	8	150	16	6°							
	S12M-STUPR11-14	12	7	150	14	7°							
	S14N-STUPR/L11	14	8	160	16	5°							
	S16Q-STUPR/L11	16	10	180	20	2°							
	S16Q-STUPR11-18	16	9	180	18	4°							
	S20R-STUPR/L11	20	12.5	200	25	2°							
	S20R-STUPR11-22	20	12.5	200	22	2°							
	S20R-STUPR/L16	20	12.5	200	25	3°				TPGT 1604□□	CS40	T-15	
	S25R-STUPR/L16	25	16	200	32	2°							

A

- 01
- 02
- 03
- 04
- 05
- 06
- 07
- 08
- 09
- 10
- 11

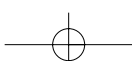

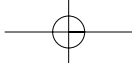

# 內徑車刀架系列/Boring Bar Series (合金鋼柄/Alloy-Steel Shank)

## SCLC/SCLP

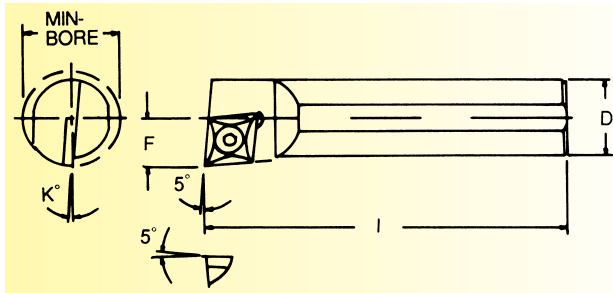
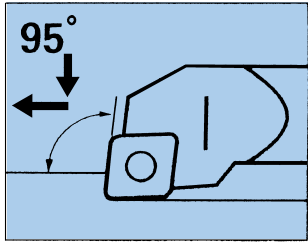

訂購編號 Style No.	產品型號 Model No.	部位尺寸 Dimensions(mm)					刀片 Insert	零件 Parts		訂價 (NT\$)
		D	F	L	B	K°				
	S08H-SCLCR/L06	8	6	100	12	9°	CCMT 0602□□	CS25	T-8	
	S08H-SCLCR06-10	8	5.5	100	10	9°				
	S10K-SCLCR/L06	10	7	125	14	7°				
	S10K-SCLCR06-12	10	6	125	12	7°				
	S12M-SCLCR/L06	12	9	150	16	6°				
	S12M-SCLCR06-	12	7	150	14	6°				
	S16Q-SCLCR/L06	16	9	180	18	7°				
	S12M-SCLCR09	12	9	150	16	7°	CCMT 09T3□□	CS35	T-15	
	S14N-SCLCR/L09	14	8	160	16	6°				
	S16Q-SCLCR09-18	16	9	180	18	7°				
	S20R-SCLCR/L09	20	13	200	25	5°				
	S25R-SCLCR/L09	25	17	200	32	5°				

	S08H-SCLPR/L06	8	6	100	12	7°	CPMT 0602□□	CS25	T-8	
	S10K-SCLPR/L06	10	7	125	14	7°				
	S12M-SCLPR/L06	12	9	150	16	6°				
	S10K-SCLPR08-12	10	6	125	12	7°	CPMT 0802□□	CS30	T-10	
	S12M-SCLPR08	12	8	150	16	6°				
	S12M-SCLPR08-14	12	7	150	14	6°				
	S12M-SCLPR09	12	8	150	16	6°	CPMT 0903□□	CS35	T-15	
	S16Q-SCLPR/L09	16	10	180	20	4°				
	S16Q-SCLPR09-18	16	9	180	18	4°				
	S20R-SCLPR/L09	20	12.5	200	25	4°				
	S20R-SCLPR09-22	20	11	200	22	4°				
	S25R-SCLPR/L09	25	16	200	32	4°				

A  
01  
02  
03  
04  
05  
06  
07  
08  
09  
10  
11

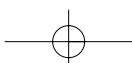

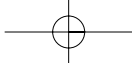

# 內徑車刀架系列/Boring Bar Series (合金鋼柄/Alloy-Steel Shank)

## SDUC

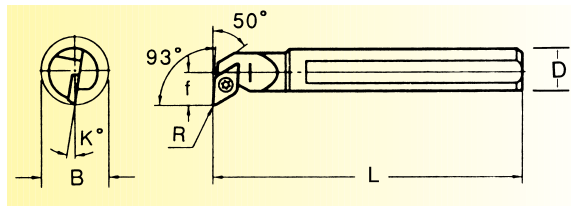
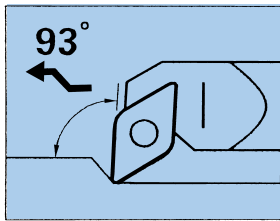

訂購編號 Style No.	產品型號 Model No.	部位尺寸 Dimensions(mm)					刀片 Insert	零件 Parts		訂價 (NT\$)
		D	f	L	B	K°				
	S10K-SDUCR/L07	10	7	125	13	10°	DCMT 0702□□	CS25	T-8	
	S12M-SDUCR/L07	12	9	150	16	8°				
	S14N-SDUCR/L07	14	8	160	16	7°				
	S16Q-SDUCR/L07	16	11	180	20	6°				
	S16Q-SDUCR/L11	16	11	180	20	6°	DCMT 11T3□□	CS35	T-15	
	S20R-SDUCR/L11	20	13	200	25	8°				
	S25R-SDUCR/L11	25	17	200	32	4°				

## SDQC

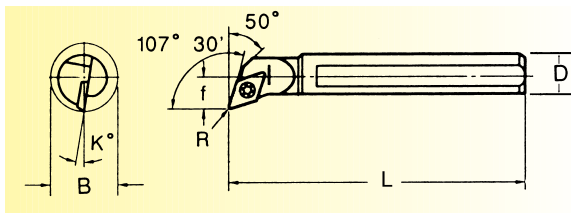
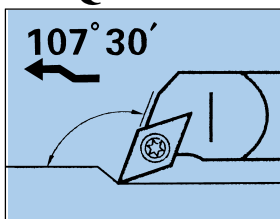

訂購編號 Style No.	產品型號 Model No.	部位尺寸 Dimensions(mm)					刀片 Insert	零件 Parts		訂價 (NT\$)
		D	f	L	B	K°				
	S10K-SDQCR/L07	10	7	125	13	10°	DCMT 0702□□	CS25	T-8	
	S12M-SDQCR/L07	12	9	150	16	8°				
	S16Q-SDQCR/L07	16	11	180	20	6°				
	S16Q-SDQCR/L11	16	11	180	20	6°	DCMT 11T3□□	CS35	T-15	
	S20R-SDQCR/L11	20	13	200	25	8°				
	S25R-SDQCR/L11	25	17	200	32	4°				

A

- 01
- 02
- 03
- 04
- 05
- 06
- 07
- 08
- 09
- 10
- 11

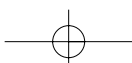

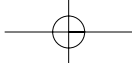

## 內徑車刀架系列/Boring Bar Series (合金鋼柄/Alloy-Steel Shank)

### SDZC

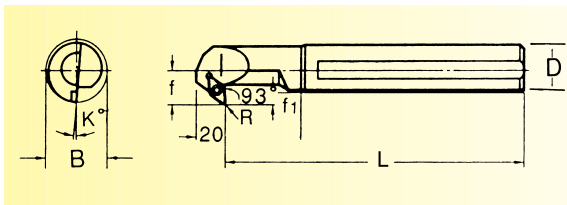
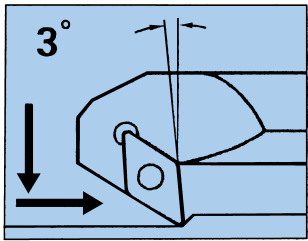

訂購編號 Style No.	產品型號 Model No.	部位尺寸 Dimensions(mm)					刀片 Insert	零件 Parts		訂價 (NT\$)		
		D	f	L	B	K°						
	S10M-SDZCR/L07	10	8.5	150	14	10°	DCMT 0702□□	CS25	T-8			
	S12M-SDZCR/L07	12	10.5	150	17	9°						
	S16Q-SDZCR/L07	16	12.5	180	21	8°						
	S20R-SDZCR/L11	20	15.5	200	26	8°	DCMT 11T3□□	CS35	T-15			
	S25R-SDZCR/L11	25	18	200	33	6°						

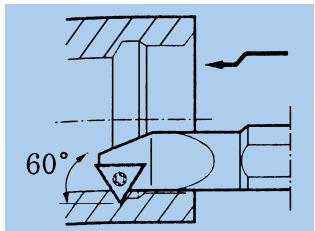

### STWC

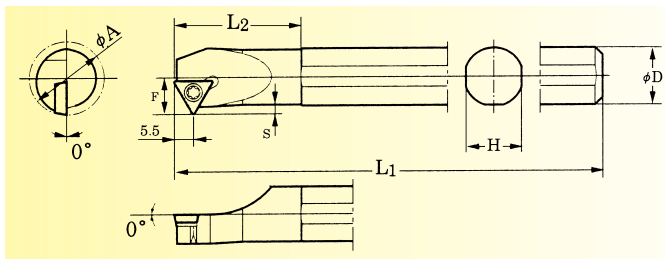

訂購編號 Style No.	產品型號 Model No.	部位尺寸 Dimensions(mm)								刀片 Insert	零件 Parts		訂價 (NT\$)	
		B	D	H	L <sub>1</sub>	L <sub>2</sub>	F	S						
	S08H-STWCR09	12	8	7	100	-	6	2.5	TCMT0902	CS25	T-8			
	S10M-STWCR11	13	10	9	150	-	6.5	2.5						
	S12M-STWCR11	15	12	11	150	-	7.5	2.5				TCMT1102		
	S16Q-STWCR11	19	16	15	180	-	9.5	2.5						
	S20R-STWCR11	23	20	18	200	-	11.5	2.5						
	S25R-STWPR16	28	25	23	200	-	14	2.5	TPMT1604	CS40	T-15			
	S25R-STWCR16	28	25	23	200	-	14	2.5	TCMT16T3	CS40	T-15			

A  
01  
02  
03  
04  
05  
06  
07  
08  
09  
10  
11

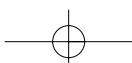

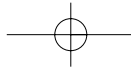

## 內徑車刀架系列/Boring Bar Series (合金鋼柄/Alloy-Steel Shank)

SNR

內徑車牙

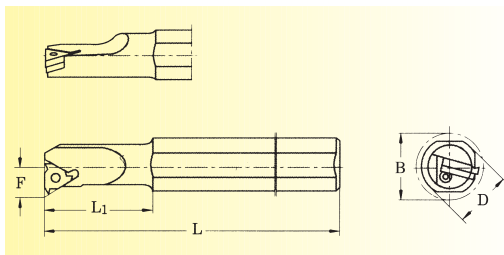
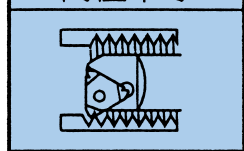

### 內徑牙刀架 / Boring Bars for Internal Threading

訂購編號 Style No.	產品型號 Model No.	部位尺寸 Dimensions(mm)				刀片 Insert	零件 Parts		訂價 (NT\$)
		D	L	L <sub>1</sub>	B				
	SIRO007- K08	16	125	18	8	8NR	CS22	T7	
	SNR1610- L11	16	140	28/17	12	11NR	CS25	T8	
	SNR1613- M16	16	150	28/17	16	16NR	CS35	T15	
	SNR2013- M16	20	150	20	16	16NR	CS35	T15	
	SNR2013- M16	20	150	35	16	16NR	CS35	T15	
	SNR16- M16	16	150	-	20	16NR	CS35	T15	
	SNR20- M16	20	150	-	24	16NR	CS35	T15	

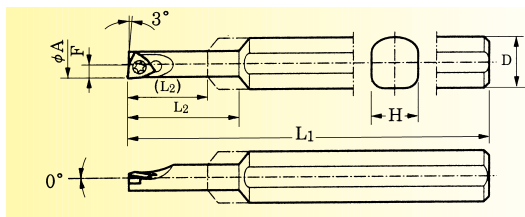
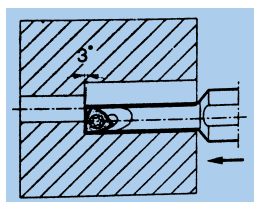

### 小徑內孔車刀架 / Boring Bars for Small Hole

訂購編號 Style No.	產品型號 Model No.	部位尺寸 Dimensions(mm)					刀片 Insert	零件 Parts		訂價 (NT\$)
		B	D	H	L <sub>2</sub>	L <sub>1</sub>				
	S0805H-SWUBR02	6	8	7	18	100	WBGT0201	CS20	T6	
	S1005H-SWUBR06-06	6	10	9	15/20	100	WBMT0601			
	S1006H-SWUBR06-07	7	10	9	20	100	WBMT0601			
	S1007H-SWUBR08-08	8	10	9	20	100	WBMT0802			
	S1205H-SWUBR06-06	6	12	11	15/20	100	WBMT0601			
	S0805H-SWUCR02-06	6	8	7	20	100	WCMT0201	CS20	T6	
	S06H-STUBR06-07	7	6	5	-	100	TBMT0601			
	S0806H-STUBR06	7	8	7	20	100	TBGT0601			
	S1006H-STUBR06	7	10	9	20	100	TBGT0601	CS18	T6	
	S1004H-SCLCR03	5	10	9	12	100	CCGT03			
	S1005H-SCLCR03	6	10	9	15	100	CCGT03			
	S1006H-SCLCR04	7	10	9	20	100	CCGT04			
	S06H-SCLCR04	7	6	5	-	100	CCGT04	CS22	T7	
	S0807H-SCLCR06	8	8	7	20	100	CCMT0602	CS25	T8	
	S1607K-SCLCR06-08	8	16	15	20	120	CCMT0602			
	S1608K-SCLCR06-09	9	16	15	20	120	CCMT0602			
	S1609K-SCLCR06-10	10	16	15	20	120	CCMT0602			

A

- 01
- 02
- 03
- 04
- 05
- 06
- 07
- 08
- 09
- 10
- 11

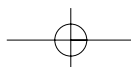

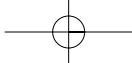

# 內徑車刀架系列/Boring Bar Series (合金鋼柄/Alloy-Steel Shank)

## GIVR

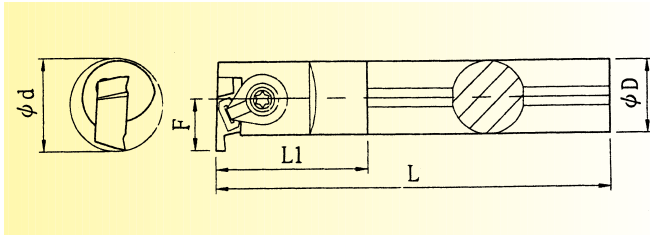
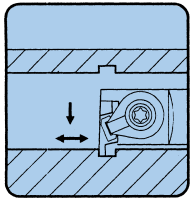

## 內徑開槽刀架 / Internal Groove Tooling Holder

訂購編號 Style No.	產品型號 Model No.	部位尺寸 Dimensions(mm)					刀片 Insert	零件 Parts			訂價 (NT\$)
		D	F	B	L	L1					
	GIVR/L1216-1SS	16	6	12	150	20	GVR 100SS-300SS	CPS-4V	T-10		
	GIVR/L1416-1S	16	7	14	150	24	GVR 100S-340S	CPS-5F	T-15		
	GIVR/L1516-1A	16	7.5	15	150	28	GVR 100A-340A	CPS-5V	T-15		
	GIVR/L1616-1A	16	8	16	150	28	GVR 100A-340A	CPS-5V	T-15		
	GIVR/L1916-1A	16	9.5	19	150	-	GVR 100A-340A	CPS-5V	T-15		
	GIVR/L2020-1B	20	10	20	180	35	GVR 145B-250B	CPS-5V	T-15		
	GIVR/L2020-2B	20	10	20	180	35	GVR 280B-400B	CPS-5V	T-15		
	GIVR/L2520-1B	20	12.5	25	200	-	GVR 145B-250B	CPS-5V	T-15		
	GIVR/L2520-2B	20	12.5	25	200	-	GVR 280B-400B	CPS-5V	T-15		
	GIVR/L2525-1C	25	12.5	25	180	50	GVR 280C-340C	CPS-6V	T-15		
	GIVR/L2525-2C	25	12.5	25	180	50	GVR 400C-500C	CPS-6V	T-15		

◎SUITABLE: KEYOCERA INSERT

## SINR

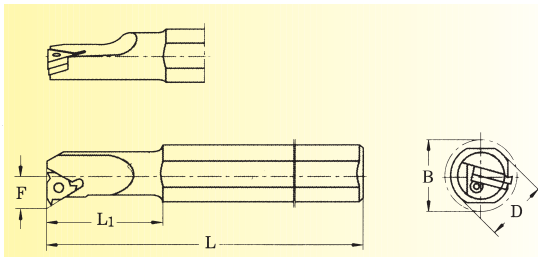
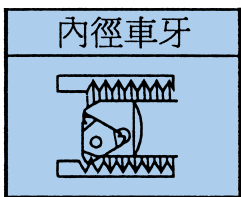

## 內徑牙刀架 / Boring Bars for Internal Threading

訂購編號 Style No.	產品型號 Model No.	部位尺寸 Dimensions(mm)				刀片 Insert	零件 Parts					訂價 (NT\$)
		D	L	L1	B							
	SINR0612-06	12	100	10	6.4	06IR	-	-	CS20	-	T-6	
	SINR0808-08	8	125	18	8	08IR	-	-	CS22	-	T-7	
	SINR0816-08	16	125	18	8	08IR	-	-	CS22	-	T-7	
	SINR1012-11	12	150	27	10	11IR/L	-	-	CS30	-	T-10	
	SINR/L-1210-11	10	125	-	12	11IR/L	-	-	CS25	-	T-8	
	SINR/L-1216-11	16	150	25	12	11IR/L	-	-	CS30	-	T-10	
	SINR/L-1516-11	16	150	30	15	11IR/L	-	-	CS30	-	T-10	
	SINR/L-2016-16	16	150	37	20	16IR/L	-	-	CS35115	-	T-15	
	SINR/L-2420S-16	20	180	40	24	16IR/L	AI16	AE16	CS35115	CS6-0306	T-15	
	SINR/L-3025S-16	25	200	40	30	16IR/L	AI16	AE16	CS35115	CS6-0306	T-15	
	SINR/L-3732S-16	32	250	45	37	16IR/L	AI16	AE16	CS35115	CS6-0306	T-15	
	SINR/L-4440T-16	40	300	32	44	16IR/L	AI16	AE16	CS35115	CS6-0306	T-15	

◎SUITABLE: KEYOCERA INSERT

A  
01  
02  
03  
04  
05  
06  
07  
08  
09  
10  
11

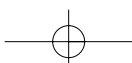

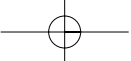

# 內徑車刀架系列/Boring Bar Series (合金鋼柄/Alloy-Steel Shank)

## SVUC

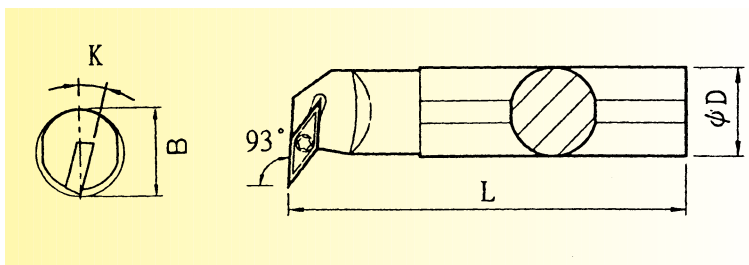
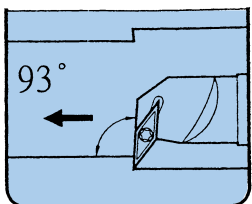

訂購編號 Style No.	產品型號 Model No.	部位尺寸 Dimensions(mm)			刀片 Insert	零件 Parts		訂價 (NT\$)
		D	B	L				
	S16Q-SVUCR/L11	16	22	180	VCMT1103	CS25	T-8	
	S20R-SVUCR/L11	20	27	200	VCMT1103	CS25	T-8	
	S25R-SVUCR/L16	25	33	200	VCMT1604	CS35	T-15	

## SVJC

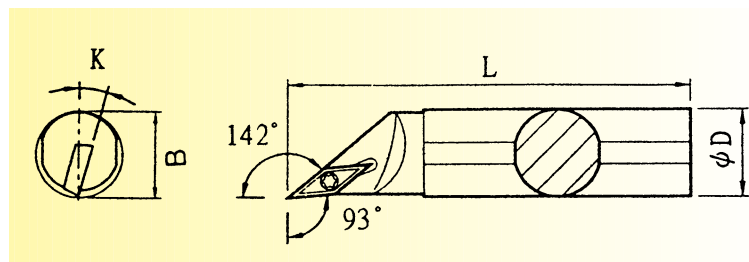
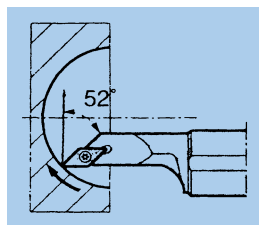

訂購編號 Style No.	產品型號 Model No.	部位尺寸 Dimensions(mm)			刀片 Insert	零件 Parts		訂價 (NT\$)
		D	B	L				
	S12M-SVJCR/L11	12	14	150	VCMT1103	CS25	T-8	
	S16Q-SVJCR/L16	16	18	180	VCMT1604	CS35	T-15	
	S20R-SVJCR/L16	20	25	200	VCMT1604	CS35	T-15	
	S25R-SVJCR/L16	25	32	200	VCMT1604	CS35	T-15	
	S32S-SVJCR/L16	32	40	250	VCMT1604	CS35	T-15	

A  
01  
02  
03  
04  
05  
06  
07  
08  
09  
10  
11

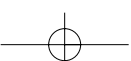

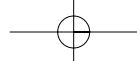

# 內徑車刀架系列/Boring Bar Series (合金鋼柄/Alloy-Steel Shank)

**MTFN**  
90°

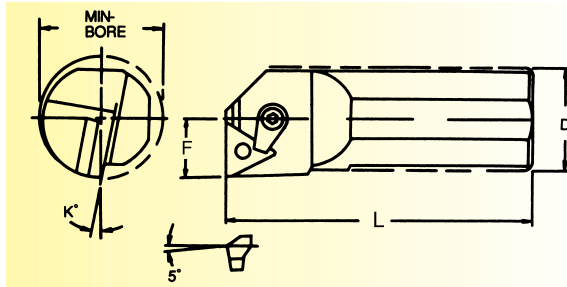

訂購編號 Style No.	產品型號 Model No.	部位尺寸 Dimensions(mm)					K°	零件 Parts					訂價 (NT\$)
		D	F	L	B	Insert 1		Insert 2	Part 1	Part 2	Part 3		
	S20R-MTFNR/L16	20	13	200	25	17°	TNMG 16 04 08	-	LCS-510	CP50-26	CS70-21		
	S25R-MTFNR/L16	25	17	200	32	12°	TNMG 16 04 08	-	LCS-510	CP50-22	CS70-22		
	S32S-MTFNR/L16	32	22	250	40	10°	TNMG 16 04 08	SMT-322	LCS-513	CP50-22	CS70-22		
	S40T-MTFNR/L16	40	27	300	50	10°	TNMG 16 04 08	SMT-322	LCS-513	CP50-22	CS70-22		
	S50U-MTFNR/L16	50	35	350	63	8°	TNMG 16 04 08	SMT-322	LCS-513	CP50-22	CS70-22		

**MTUNR**  
93°

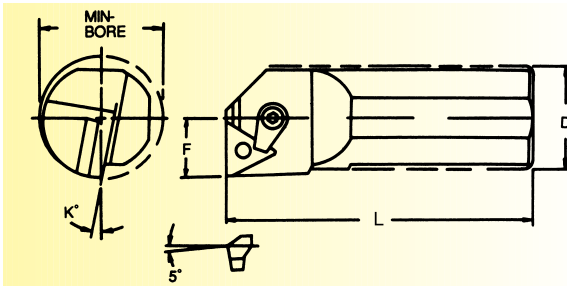

訂購編號 Style No.	產品型號 Model No.	部位尺寸 Dimensions(mm)					K°	零件 Parts					訂價 (NT\$)
		D	F	L	B	Insert 1		Insert 2	Part 1	Part 2	Part 3		
	S20R-MTUNR/L16	20	13	200	25	17°	TNMG 16 04 08	-	LCS-510	CP50-26	CS70-21		
	S25R-MTUNR/L16	25	17	200	32	12°	TNMG 16 04 08	-	LCS-510	CP50-22	CS70-22		
	S32S-MTUNR/L16	32	22	250	40	10°	TNMG 16 04 08	SMT-322	LCS-513	CP50-22	CS70-22		
	S40T-MTUNR/L16	40	27	300	50	10°	TNMG 16 04 08	SMT-322	LCS-513	CP50-22	CS70-22		
	S50U-MTUNR/L16	50	35	350	63	8°	TNMG 16 04 08	SMT-322	LCS-513	CP50-22	CS70-22		

**MTUNR-A**  
93°

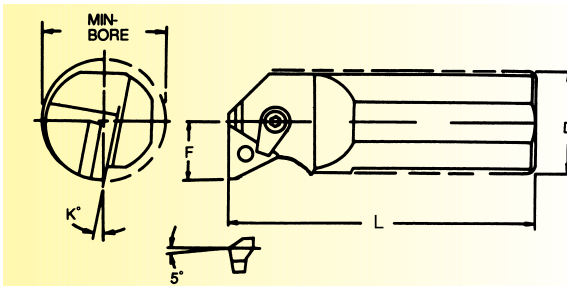

訂購編號 Style No.	產品型號 Model No.	部位尺寸 Dimensions(mm)					K°	零件 Parts					訂價 (NT\$)
		D	F	L	B	Insert 1		Insert 2	Part 1	Part 2	Part 3		
	S20R-MTUNR/L16A	20	13	200	25	17°	TNMG 16 04 08	-	LCS-510	CP50-26	CS70-21		
	S25R-MTUNR/L16A	25	17	200	32	12°	TNMG 16 04 08	-	LCS-510	CP50-22	CS70-22		
	S32S-MTUNR/L16A	32	22	250	40	10°	TNMG 16 04 08	SMT-322	LCS-513	CP50-22	CS70-22		
	S40T-MTUNR/L16A	40	27	300	50	10°	TNMG 16 04 08	SMT-322	LCS-513	CP50-22	CS70-22		
	S50U-MTUNR/L16A	50	35	350	63	8°	TNMG 16 04 08	SMT-322	LCS-513	CP50-22	CS70-22		

A  
01  
02  
03  
04  
05  
06  
07  
08  
09  
10  
11

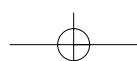

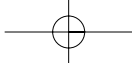

## 內徑車刀架系列/Boring Bar Series (合金鋼柄/Alloy-Steel Shank)

**MDUN**  
93°

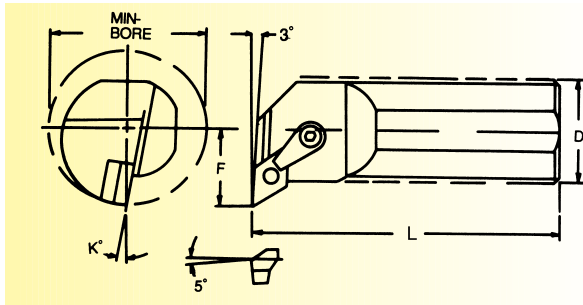

訂購編號 Style No.	產品型號 Model No.	部位尺寸 Dimensions(mm)					刀片 Insert	零件 Parts					訂價 (NT\$)
		D	F	L	B	K°							
	S25R- MDUNR/L15	25	17	200	32	12°							
	S32S- MDUNR/L15	32	22	250	40	10°							
	S40T- MDUNR/L15	40	27	300	50	10°							
	S50U- MDUNR/L15	50	35	350	63	10°							

**CTFP**  
90°

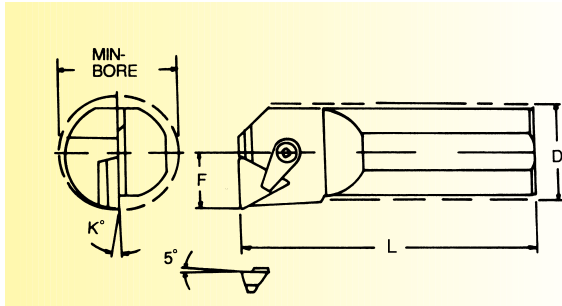

訂購編號 Style No.	產品型號 Model No.	部位尺寸 Dimensions(mm)					刀片 Insert	零件 Parts					訂價 (NT\$)
		D	F	L	B	K°							
	S16Q- CTFPR/L11	16	11	180	22	0°		-	-				
	S20R- CTFPR/L11	20	13	200	36	0°		-	-				
	S25R- CTFPR/L16	25	17	200	34	3°							
	S32S- CTFPR/L16	32	22	250	44	3°							

**A**

- 01
- 02
- 03
- 04
- 05
- 06
- 07
- 08
- 09
- 10
- 11

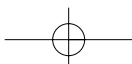

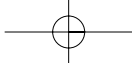

# 內徑車刀架系列/Boring Bar Series (合金鋼柄/Alloy-Steel Shank)

**MWLN**  
95°

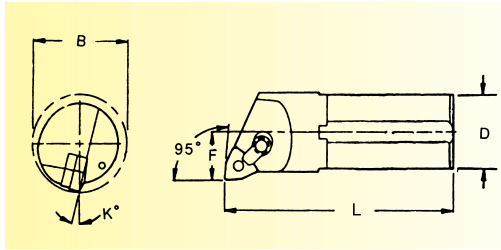

訂購編號 Style No.	產品型號 Model No.	部位尺寸 Dimensions(mm)					刀片 Insert	零件 Parts					訂價 (NT\$)
		D	F	L	B	K°							
	S20R- MWLNR/L08	20	13	200	25	17°	WNLG 08 04 □□	-	LCS- 511	CP50- 26	CS70- 21		
	S25R- MWLNR/L08	25	17	200	32	14°	WNLG 08 04 □□	-	LCS- 511	CP50- 22	CS70- 22		
	S32S- MWLNR/L08	32	22	250	40	14°	WNLG 08 04 □□	SMW-432	LCS- 617	CP50- 22	CS70- 22		
	S40T- MWLNR/L08	40	27	300	50	12°	WNLG 08 04 □□	SMW-432	LCS- 617	CP50- 22	CS70- 22		
	S50U- MWLNR/L08	50	35	350	63	12°	WNLG 08 04 □□	SMW-432	LCS- 617	CP50- 22	CS70- 22		

**MCLN**  
95°

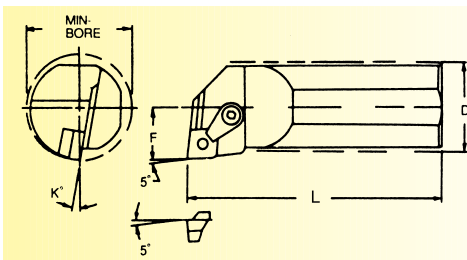

訂購編號 Style No.	產品型號 Model No.	部位尺寸 Dimensions(mm)					刀片 Insert	零件 Parts					訂價 (NT\$)
		D	F	L	B	K°							
	S20R- MCLNR/L12	20	13	200	25	17°	CNMG 12 04 08	-	LCS- 511	CP50- 26	CS70- 21		
	S25R- MCLNR/L12	25	17	200	32	14°	CNMG 12 04 08	-	LCS- 511	CP50- 22	CS70- 22		
	S32S- MCLNR/L12	32	22	250	40	14°	CNMG 12 04 08	SMC- 432	LCS- 617	CP50- 22	CS70- 22		
	S40T- MCLNR/L12	40	27	300	50	12°	CNMG 12 04 08	SMC- 432	LCS- 617	CP50- 22	CS70- 22		
	S50U- MCLNR/L12	50	35	350	63	12°	CNMG 12 04 08	SMC- 432	LCS- 617	CP50- 22	CS70- 22		

**MCKN**  
75°

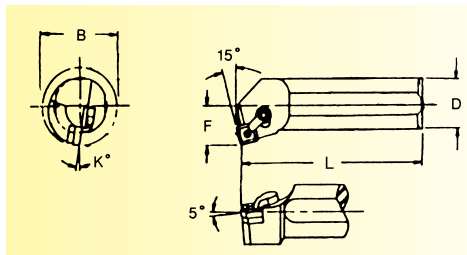

訂購編號 Style No.	產品型號 Model No.	部位尺寸 Dimensions(mm)					刀片 Insert	零件 Parts					訂價 (NT\$)
		D	F	L	B	K°							
	S20R- MCKNR/L12	20	13	200	25	17°	CNMG 12 04 □□	-	LCS- 511	CP50- 26	CS70- 21		
	S25R- MCKNR/L12	25	17	200	32	14°	CNMG 12 04 □□	-	LCS- 511	CP50- 22	CS70- 22		
	S32S- MCKNR/L12	32	22	250	40	12°	CNMG 12 04 □□	SMC- 432	LCS- 617	CP50- 22	CS70- 22		
	S40T- MCKNR/L12	40	27	300	50	12°	CNMG 12 04 □□	SMC- 432	LCS- 617	CP50- 22	CS70- 22		
	S50U- MCKNR/L12	50	35	350	63	12°	CNMG 12 04 □□	SMC- 432	LCS- 617	CP50- 22	CS70- 22		

A  
01  
02  
03  
04  
05  
06  
07  
08  
09  
10  
11

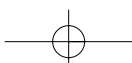

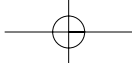

# 內徑車刀架系列/Boring Bar Series (超微粒碳化鎢鋼柄/Micro Grain Tungsten Carbide Steel Shank)

## STFC

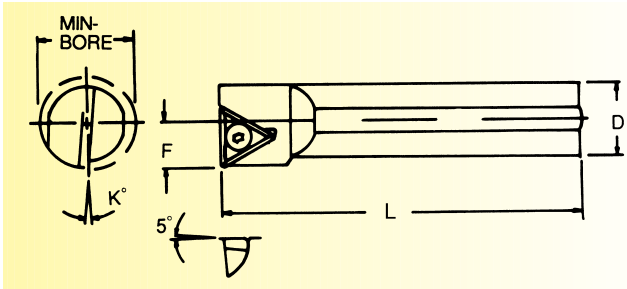
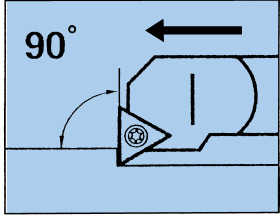

訂購編號 Style No.	產品型號 Model No.	部位尺寸 Dimensions(mm)					刀片 Insert	零件 Parts		訂價 (NT\$)
		D	F	L	B	K°				
	C08K-STFCR09	8	6	125	12	12°	TCMM 0902□□	CS25	T-8	
	C10M-STFCR09	10	7	150	14	15°				
	C12Q-STFCR09	12	9	180	16	10°				
	C12Q-STFCR11	12	9	180	16	10°	TCMM 1102□□	CS25	T-8	
	C16R-STFCR11	16	11	200	20	6°				
	C20S-STFCR11	20	13	250	25	3°				

## STUB

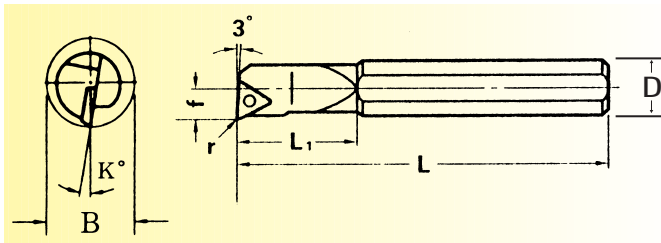
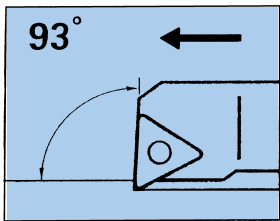

B  
01  
02  
03  
04  
05

訂購編號 Style No.	訂購編號 Model No.	部位尺寸 Dimensions(mm)					刀片 Insert	零件 Parts		訂價 (NT\$)
		D	F	L	B	L1				
	C06J-STUBR/L06-07	6	3.5	110	7	-	TBGT 0601□□	CS20	T-6	
	C0807K-STUBR/L06-08	8	4	125	8	25				
	C0807K-STUBR/L06-08	8	4	125	8	35				
	C07J-STUBR06-08	6	4	110	8	-				
	C08K-STUBR06-09	8	4.5	125	9	-				

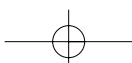

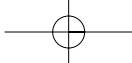

# 內徑車刀架系列/Boring Bar Series (超微粒碳化鎢鋼柄/Micro Grain Tungsten Carbide Steel Shank)

## STUP

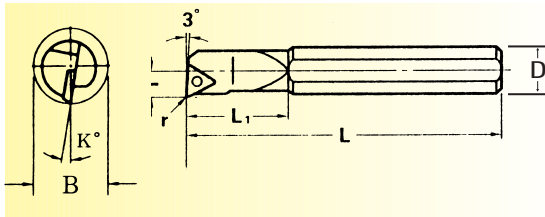
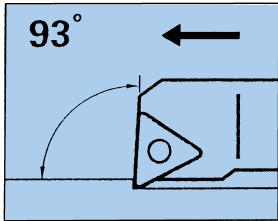

訂購編號 Style No.	產品型號 Model No.	部位尺寸 Dimensions(mm)					刀片 Insert	零件 Parts		訂價 (NT\$)
		D	F	L	B	K°				
	C08K-STUPR08	8	5	125	10	10°	TPGT0802	CS22	T-7	
	C08K-STUPR09	8	5	125	10	10°	TPMT 0902□□	CS25	T-8	
	C10M-STUPR09	10	6	150	12	8°				
	C12M-STUPR09	12	8	150	14	5°				
	C12Q-STUPR09	12	7	180	14	5°				
	C10M-STUPR11	10	6	150	12	8°	TPGT 1103□□	CS30	T-10	
	C12M-STUPR11	12	8	150	14	6°				
	C12Q-STUPR11	12	7	180	14	7°				
	C16M-STUPR11	16	10	150	18	2°				
	C16R-STUPR11	16	9	200	18	4°				
	C20Q-STUPR11	20	11.5	180	22	2°				
	C20R-STUPR11	20	11.5	200	22	2°				
	C20S-STUPR11	20	11.5	250	22	2°				
	C20S-STUPR16	20	12.5	250	25	3°	TPGT 1604□□	CS40	T-10	
	C25T-STUPR16	25	16	300	32	2°				

## STUC

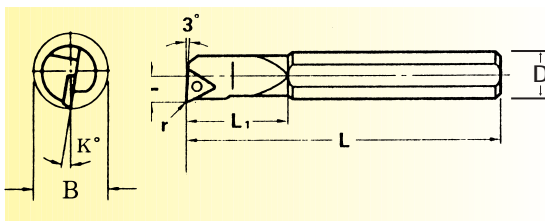
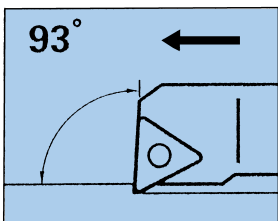

訂購編號 Style No.	產品型號 Model No.	部位尺寸 Dimensions(mm)					刀片 Insert	零件 Parts		訂價 (NT\$)
		D	F	I	B	K°				
	C08K-STUCR09	8	5.5	125	10	12°	TCMM 0902□□	CS25	T8	
	C10M-STUCR09	10	6.5	150	12	15°				
	C12M-STUCR09	12	7.5	150	14	10°				
	C12Q-STUCR09	12	7.5	180	14	10°				
	C10M-STUCR11	12	6.5	180	12	10°	TCMM 1102□□	CS25	T8	
	C12M-STUCR11	12	7.5	150	14	10°				
	C12Q-STUCR11	12	7.5	180	14	10°				
	C16M-STUCR11	16	9.5	150	18	6°				
	C16R-STUCR11	16	9.5	200	18	6°				
	C20Q-STUCR11	20	11.5	180	22	3°				
	C20R-STUCR11	20	11.5	200	22	3°				
	C20S-STUCR11	20	11.5	250	22	3°				

B  
01  
02  
03  
04  
05

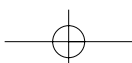

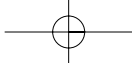

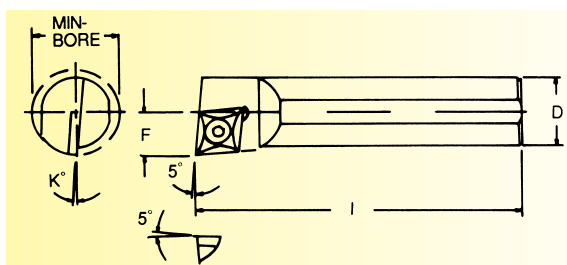
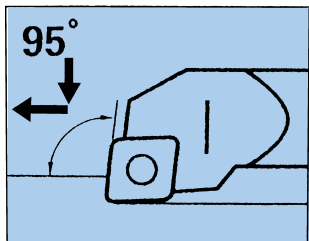

# 內徑車刀架系列/Boring Bar Series (超微粒碳化鎢鋼柄/Micro Grain Tungsten Carbide Steel Shank)

## SCLC/SCLP

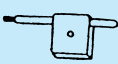

訂購編號 Style No.	產品型號 Model No.	部位尺寸 Dimensions(mm)					刀片 Insert 	零件 Parts 		訂價 (NT\$)
		D	F	L	B	K°				
	C0807K-SCLCR06-08	8	4	125	8	9°	CCMT 0602□□	CS25	T-8	
	C08K-SCLCR06-09	8	4.5	125	9	9°				
	C08K-SCLCR06-10	8	5.5	125	10	9°				
	C10M-SCLCR06	10	6.5	150	12	7°				
	C12K-SCLCR06	12	7.5	125	14	7°				
	C12M-SCLCR06	12	7.5	150	14	6°				
	C12Q-SCLCR06	12	7.5	180	14	6°				
	C16R-SCLCR06	16	9	200	18	7°				
	C12M-SCLCR09	12	7	150	14	6°	CCMT 09T3□□	CS35	T-15	
	C12Q-SCLCR09	12	7	180	14	6°				
	C16M-SCLCR09	16	11	150	18	7°				
	C16R-SCLCR09	16	9	200	18	7°				
	C20Q-SCLCR09	20	11.5	180	22	5°				
	C20R-SCLCR09	20	11.5	200	22	5°				
	C20S-SCLCR09	20	13	250	22	5°				
	C25T-SCLCR09	25	17	300	32	5°				

	C08K-SCLPR06	8	6	125	12	7°	CPMT 0602□□	CS25	T-8	
	C10M-SCLPR06	10	7	150	14	7°				
	C12Q-SCLPR06	12	9	180	16	6°				
	C10M-SCLPR08-12	10	6	150	12	7°	CPMT 0802□□	CS30	T-10	
	C12Q-SCLPR08	12	8	180	16	6°				
	C12Q-SCLPR08-14	12	7	180	14	6°				
	C12Q-SCLPR09	12	8	180	16	6°	CPMT 0903□□	CS40	T-15	
	C16R-SCLPR09	16	10	200	20	4°				
	C16R-SCLPR09-18	16	9	200	18	4°				
	C20S-SCLPR09	20	12.5	250	25	4°				
	C20S-SCLPR09-22	20	11	250	22	4°				
	C25T-SCLPR09	25	16	300	32	4°				

**B**  
01  
02  
03  
04  
05

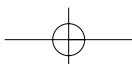

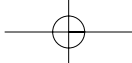

# 內徑車刀架系列/Boring Bar Series (超微粒碳化鎢鋼柄/Micro Grain Tungsten Carbide Steel Shank)

## SDUC

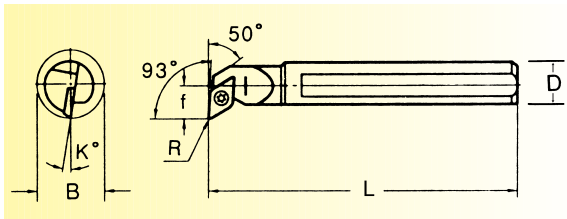
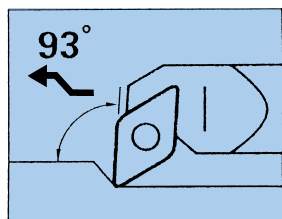

訂購編號 Style No.	產品型號 Model No.	部位尺寸 Dimensions(mm)					刀片 Insert	零件 Parts		訂價 (NT\$)
		D	f	L	B	K°				
	C10M-SDUCR07	10	7	150	13	10°	DCMT 0702□□	CS25	T-8	
	C12K-SDUCR07	12	9	125	16	8°				
	C12M-SDUCR07	12	9	150	16	8°				
	C12Q-SDUCR07	12	9	180	16	8°				
	C16M-SDUCR07	16	11	150	20	6°				
	C16R-SDUCR07	16	11	200	20	6°				
	C16R-SDUCR11	16	11	200	20	6°	DCMT 11T3□□	CS40	T-15	
	C20Q-SDUCR11	20	13	180	25	8°				
	C20R-SDUCR11	20	13	200	25	8°				
	C20S-SDUCR11	20	13	250	25	8°				
	C25R-SDUCR11	25	17	200	32	4°				
	C25S-SDUCR11	25	17	250	32	4°				
	C25T-SDUCR11	25	17	300	32	4°				

## SDQC

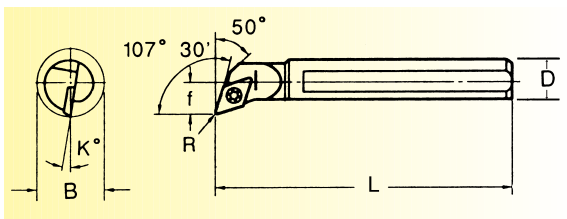
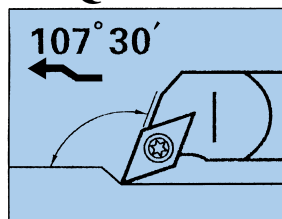

B  
01  
02  
03  
04  
05

訂購編號 Style No.	產品型號 Model No.	部位尺寸 Dimensions(mm)					刀片 Insert	零件 Parts		訂價 (NT\$)
		D	f	L	B	K°				
	C10M-SDQCR07	10	7	150	13	10°	DCMT 0702□□	CS25	T-8	
	C12Q-SDQCR07	12	9	180	16	8°				
	C16R-SDQCR07	16	11	200	20	6°				
	C20S-SDQCR11	20	13	250	25	8°	DCMT 11T3□□	CS40	T-15	
	C25T-SDQCR11	25	17	300	32	4°				

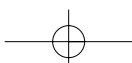

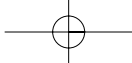

# 內徑車刀架系列/Boring Bar Series (超微粒碳化鎢鋼柄/Micro Grain Tungsten Carbide Steel Shank)

## SCLC

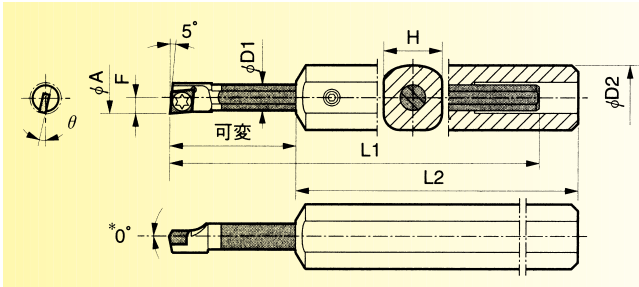
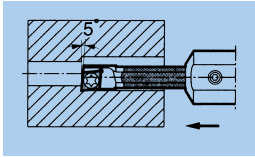

訂購編號 Style No.	產品型號 Model No.	部位尺寸 Dimensions(mm)							刃片 Insert	零件 Parts		訂價 (NT\$)
		phi A	phi D1	H	L1	L2	F	phi D2				
	C04G-SCLCR03-05	5	4	14	90	100	2.5	16	CCGT0301	CS18	T6	
	C05H-SCLCR03-06	6	5	14	100	100	3	16				
	C06J-SCLCR04-07	7	6	14	110	100	3.5	16	CCGT04T0	CS22	T7	
	C07J-SCLCR04-08	8	7	14	110	100	4	16				

## SWUB

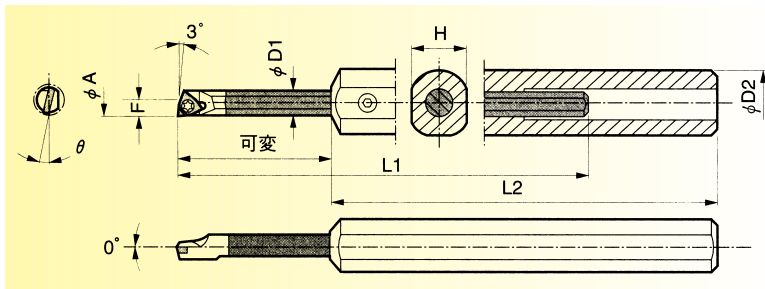
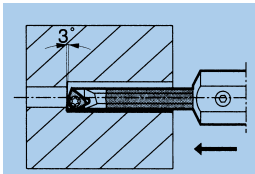

訂購編號 Style No.	產品型號 Model No.	部位尺寸 Dimensions(mm)							刃片 Insert	零件 Parts		訂價 (NT\$)		
		phi A	phi D1	H	L1	L2	F	phi D2						
	C04G-SWUBR06-5.5	5.5	4	14	90	100	3	16	WBMT0601	CS20	T6			
	C05H-SWUBR06-06	6	5	14	100	100	3	16						
	C06J-SWUBR06-07	7	6	14	110	100	3.5	16						
	C07J-SWUBR06-08	8	7	14	110	100	4	16						
	C0807K-SWUBR06-08	8	8	14	125	100	4	16						

**B**  
01  
02  
03  
04  
05

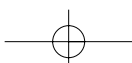

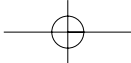

## 外徑車刀架系列/Tool Holders Series

### SDQC

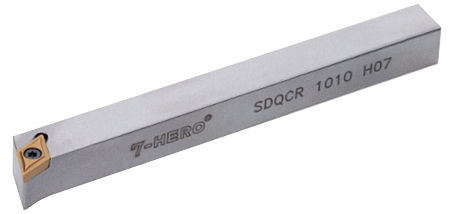
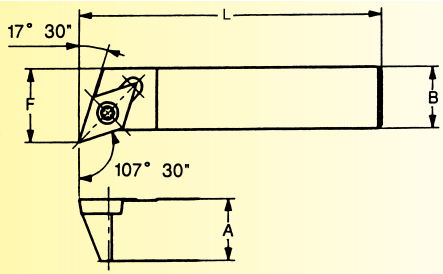

訂購編號 Style No.	產品型號 Model No.	部位尺寸 Dimensions(mm)				刀片 Insert	零件 Parts			訂價 (NT\$)
		A	B	L	F					
	SDQCR/L- 1010H07	10	10	100	12	DC □ □ 0702 □ □	CS25	T- 8		
	SDQCR/L- 1212H11	12	12	100	16	DC □ □ 11T3 □ □	CS40	T- 15		
	SDQCR/L- 1616H11	16	16	100	20	DC □ □ 11T3 □ □	CS40	T- 15		
	SDQCR/L- 2020K11	20	20	125	25	DC □ □ 11T3 □ □	CS40	T- 15		
	SDQCR/L- 2525M11	25	25	150	32	DC □ □ 11T3 □ □	CS40	T- 15		

### SVJC

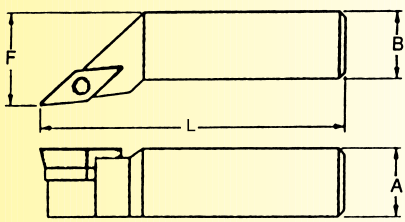

訂購編號 Style No.	產品型號 Model No.	部位尺寸 Dimensions(mm)				刀片 Insert		零件 Parts			訂價 (NT\$)
		A	B	L	F						
	SVJCR/L- 1010K11	10	10	125	10.5	VC □ □ 1103 □ □	-	-	CS25	T- 8	
	SVJCR/L- 1212K11	12	12	125	12.5	VC □ □ 1103 □ □	-	-	CS25	T- 8	
	SVJCR/L- 1616H11	16	16	100	16.5	VC □ □ 1103 □ □	-	-	CS25	T- 8	
	SVJCR/L- 1616K11	16	16	125	16.5	VC □ □ 1103 □ □	-	-	CS25	T- 8	
	SVJCR/L- 1616K16	16	16	125	16.5	VC □ □ 1604 □ □	-	-	CS35	T-15	
	SVJCR/L- 2020K16	20	20	125	25	VC □ □ 1604 □ □	SMV- 321	SN535	CS35	T-15	
	SVJCR/L- 2525M16	25	25	150	32	VC □ □ 1604 □ □	SMV- 321	SN535	CS35	T-15	

### SVVC

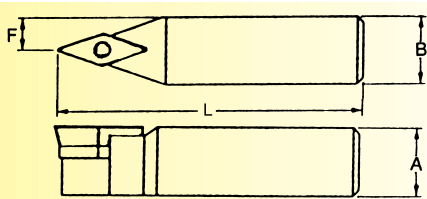

訂購編號 Style No.	產品型號 Model No.	部位尺寸 Dimensions(mm)				刀片 Insert		零件 Parts			訂價 (NT\$)
		A	B	L	F						
	SVVCN- 1010K11	10	10	100	5	VC □ □ 1103 □ □	-	-	CS25	T- 8	
	SVVCN- 1212K11	12	12	100	6	VC □ □ 1103 □ □	-	-	CS25	T- 8	
	SVVCN- 1616K11	16	16	100	8	VC □ □ 1103 □ □	-	-	CS25	T- 8	
	SVVCN- 2020K16	20	20	125	10	VC □ □ 1604 □ □	SMV- 321	SN535	CS35	T-15	
	SVVCN- 2525M16	25	25	150	12.5	VC □ □ 1604 □ □	SMV- 321	SN535	CS35	T-15	

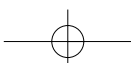

C  
01  
02  
03  
04  
05  
06  
07  
08  
09  
10  
11  
12  
13  
14

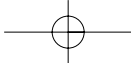

## 外徑車刀架系列/Tool Holders Series

### SDJC

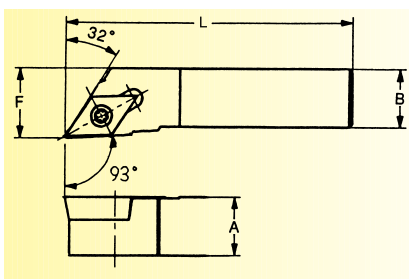

### SDJC-N

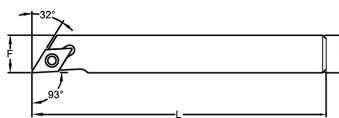

訂購編號 Style No.	產品型號 Model No.	部位尺寸 Dimensions(mm)				刀片 Insert	零件 Parts		訂價 (NT\$)
		A	B	L	F				
	SDJCR/L-0808H07/N	8	8	100	10		CS25	T-8	
	SDJCR/L-1010K07/N	10	10	100	12		CS25	T-8	
	SDJCR/L-1212K11/N	12	12	100	16		CS40	T-15	
	SDJCR/L-1616H11/N	16	16	100	20		CS40	T-15	
	SDJCR/L-1616K11/N	16	16	125	20		CS40	T-15	
	SDJCR/L-2020K11	20	20	125	25		CS40	T-15	
	SDJCR/L-2525M11	25	25	150	32		CS40	T-15	

### SDAC

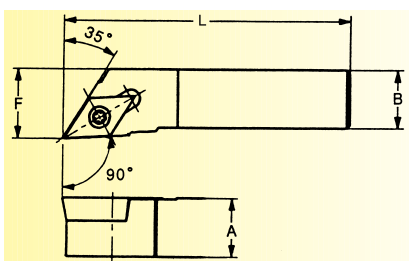

訂購編號 Style No.	產品型號 Model No.	部位尺寸 Dimensions(mm)				刀片 Insert	零件 Parts		訂價 (NT\$)
		A	B	L	F				
	SDACR/L-0808H07	8	8	100	8.5		CS25	T-8	
	SDACR/L-1010H07	10	10	100	10.5		CS25	T-8	
	SDACR/L-1212H11	12	12	100	12.5		CS40	T-15	
	SDACR/L-1616H11	16	16	100	16.5		CS40	T-15	

### SDNCN

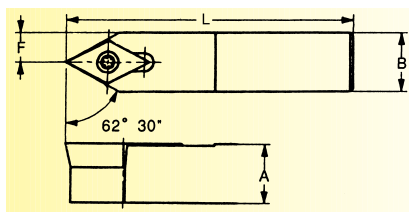

訂購編號 Style No.	產品型號 Model No.	部位尺寸 Dimensions(mm)				刀片 Insert	零件 Parts		訂價 (NT\$)
		A	B	L	F				
	SDNCN-0808H07	8	8	100	4		CS25	T-8	
	SDNCN-1010H07	10	10	100	5		CS25	T-8	
	SDNCN-1212H11	12	12	100	6		CS40	T-15	
	SDNCN-1616H11	16	16	100	8		CS40	T-15	
	SDNCN-2020K11	20	20	125	10		CS40	T-15	
	SDNCN-2525M11	25	25	150	12.5		CS40	T-15	

C

- 01
- 02
- 03
- 04
- 05
- 06
- 07
- 08
- 09
- 10
- 11
- 12
- 13
- 14

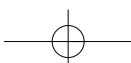

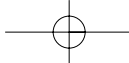

## 外徑車刀架系列/Tool Holders Series

### SCLC

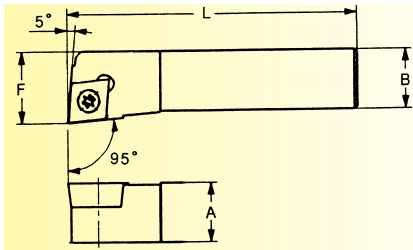

訂購編號 Style No.	產品型號 Model No.	部位尺寸 Dimensions(mm)				刀片 Insert	零件 Parts		訂價 (NT\$)
		A	B	L	F				
	SCLCR/L- 0808H06	8	8	100	10	CC□□0602□□	CS25	T- 8	
	SCLCR/L- 1010H06	10	10	100	12	CC□□0602□□	CS25	T- 8	
	SCLCR/L- 1212H09	12	12	100	16	CC□□09T3□□	CS35	T- 15	
	SCLCR/L- 1616H09	16	16	100	20	CC□□09T3□□	CS35	T- 15	
	SCLCR/L- 2020K09	20	20	125	25	CC□□09T3□□	CS35	T- 15	
	SCLCR/L- 2525M09	25	25	150	32	CC□□09T3□□	CS35	T- 15	
	SCLCR/L- 2020K12	20	20	125	25	CC□□1204□□	CS40	T- 15	
	SCLCR/L- 2525M12	25	25	150	32	CC□□1204□□	CS40	T- 15	

### SCAC

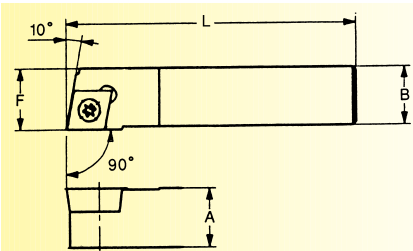

訂購編號 Style No.	產品型號 Model No.	部位尺寸 Dimensions(mm)				刀片 Insert	零件 Parts		訂價 (NT\$)
		A	B	L	F				
	SCACR/L- 0808H06	8	8	100	8.5	CC□□0602□□	CS25	T- 8	
	SCACR/L- 1010H06	10	10	100	10.5	CC□□0602□□	CS25	T- 8	
	SCACR/L- 1212H09	12	12	100	12.5	CC□□09T3□□	CS35	T- 15	

### SCLC-N

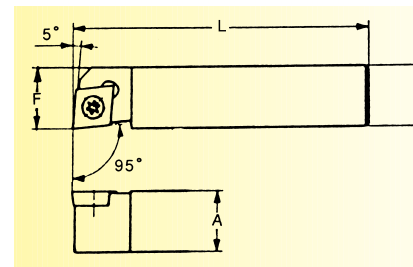

訂購編號 Style No.	產品型號 Model No.	部位尺寸 Dimensions(mm)				刀片 Insert	零件 Parts		訂價 (NT\$)
		A	B	L	F				
	SCLCR/L- 0808H06N	8	8	100	8	CC□□0602□□	CS25	T- 8	
	SCLCR/L- 1010H06N	10	10	100	10	CC□□0602□□	CS25	T- 8	
	SCLCR/L- 1212H09N	12	12	100	12	CC□□09T3□□	CS35	T- 15	
	SCLCR/L- 1616H09N	16	16	100	16	CC□□09T3□□	CS35	T- 15	

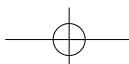

C  
01  
02  
03  
04  
05  
06  
07  
08  
09  
10  
11  
12  
13  
14

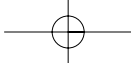

## 外徑車刀架系列/Tool Holders Series

### WWLN 95°

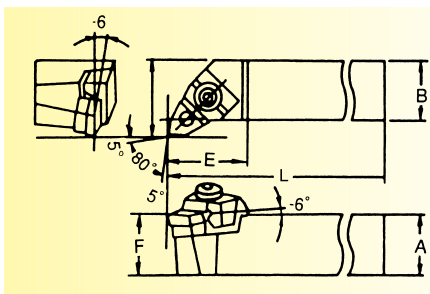

訂購編號 Style No.	產品型號 Model No.	部位尺寸 Dimensions(mm)					刀片 Insert		零件 Parts					訂價 (NT\$)
		A	B	L	E	F								
	WWLNR/L- 2020K08	20	20	125	32	25								
	WWLNR/L- 2525M08	25	25	150	32	32								
	WWLNR/L- 3225P08	32	25	170	32	32								

### MWLN

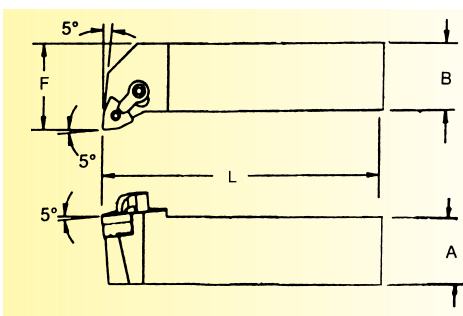

訂購編號 Style No.	產品型號 Model No.	部位尺寸 Dimensions(mm)				刀片 Insert		零件 Parts				訂價 (NT\$)
		A	B	L	F							
	MWLN/L- 2020K08	20	20	125	25							
	MWLN/L- 2525M08	25	25	150	32							
	MWLN/L- 3225P08	32	25	170	32							
	MWLN/L- 3232P08	32	32	170	40							

### STAC

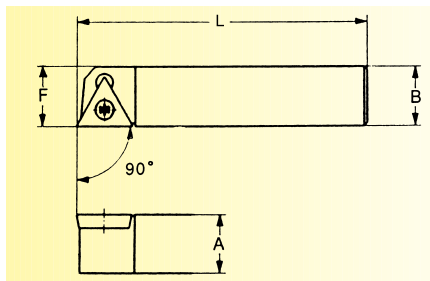

訂購編號 Style No.	產品型號 Model No.	部位尺寸 Dimensions(mm)				刀片 Insert	零件 Parts		訂價 (NT\$)
		A	B	L	F				
	STACR/L- 0808H06	8	8	100	8.5				
	STACR/L- 1010H09	10	10	100	10.5				
	STACR/L- 1212H11	12	12	100	12.5				
	STACR/L- 1616H11	16	16	100	16.5				

- C
- 01
- 02
- 03
- 04
- 05
- 06
- 07
- 08
- 09
- 10
- 11
- 12
- 13
- 14

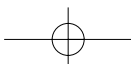

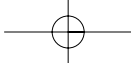

## 外徑車刀架系列/Tool Holders Series

**WTJN**  
93°

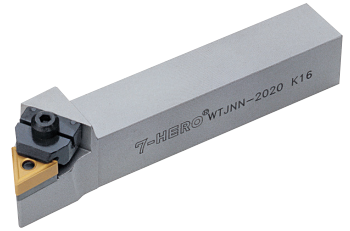
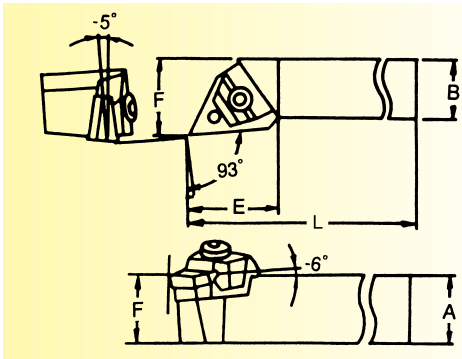

訂購編號 Style No.	產品型號 Model No.	部位尺寸 Dimensions(mm)					刀片 Insert		零件 Parts					訂價 (NT\$)
		A	B	L	E	F								
	WTJNR/L- 2020K16	20	20	125	32	25								
	WTJNR/L- 2525M16	25	25	150	32	32								

**WTEN**  
60°

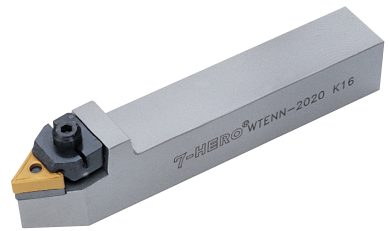
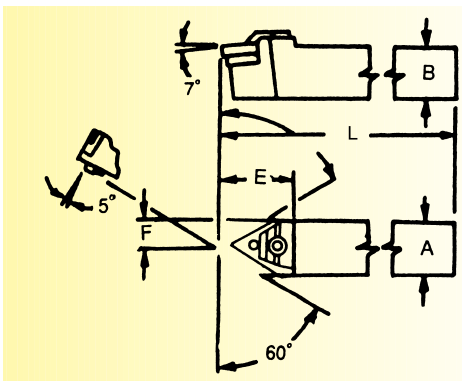

訂購編號 Style No.	產品型號 Model No.	部位尺寸 Dimensions(mm)					刀片 Insert		零件 Parts					訂價 (NT\$)
		A	B	L	E	F								
	WTENN- 2020K16	20	20	125	32	10								
	WTENN- 2525M16	25	25	150	38	12.5								

**WTXN**

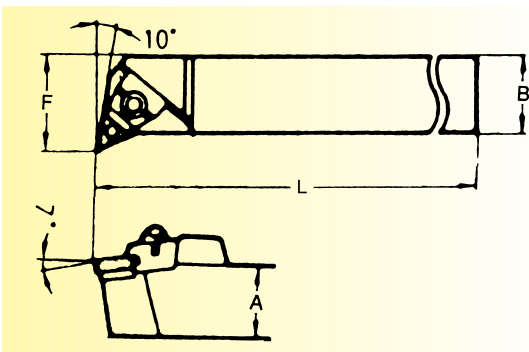

訂購編號 Style No.	產品型號 Model No.	部位尺寸 Dimensions(mm)					刀片 Insert		零件 Parts					訂價 (NT\$)
		A	B	L	E	F								
	WTXNR/L- 2020K16	20	20	125	32	25								
	WTXNR/L- 2525M16	25	25	150	32	32								

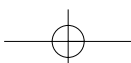

C  
01  
02  
03  
04  
05  
06  
07  
08  
09  
10  
11  
12  
13  
14

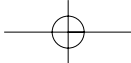

## 外徑車刀架系列/Tool Holders Series

### MDJN 93°

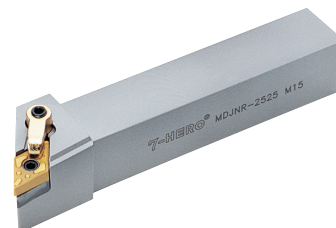
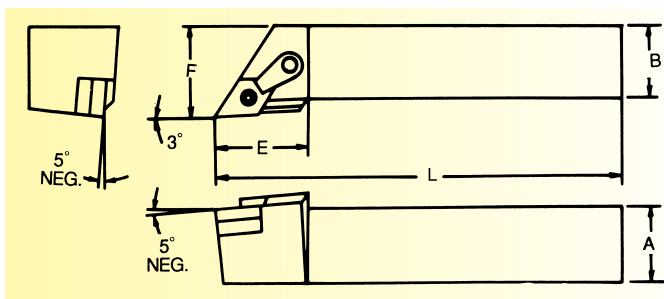

訂購編號 Style No.	產品型號 Model No.	部位尺寸 Dimensions(mm)					刀片 Insert	零件 Parts					訂價 (NT\$)
		A	B	L	E	F							
	MDJNR/L- 2020K15	20	20	125	36	25							
	MDJNR/L- 2525M15	25	25	150	36	32							
	MDJNR/L- 3225P15	32	25	170	36	32							

### MDNN 63°

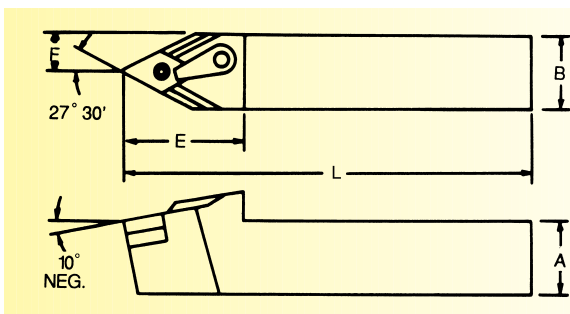

訂購編號 Style No.	產品型號 Model No.	部位尺寸 Dimensions(mm)					刀片 Insert	零件 Parts					訂價 (NT\$)
		A	B	L	E	F							
	MDNNR/L- 2525M15	25	25	150	41	12.5							
	MDNNR/L- 3225P15	32	25	170	41	12.5							

### MVJN 93°

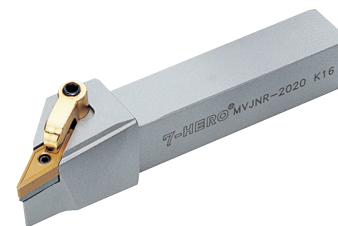
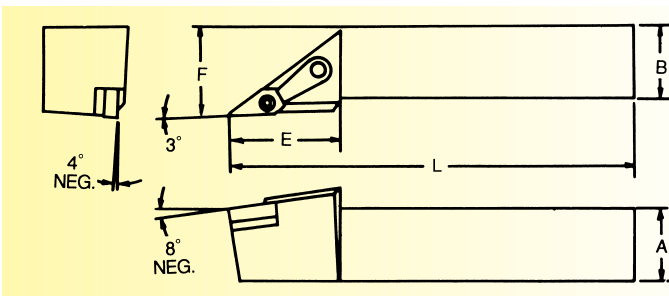

訂購編號 Style No.	產品型號 Model No.	部位尺寸 Dimensions(mm)					刀片 Insert	零件 Parts					訂價 (NT\$)
		A	B	L	E	F							
	MVJNR/L- 2020K16	20	20	125	37	25							
	MVJNR/L- 2525M16	25	25	150	37	32							
	MVJNR/L- 3225P16	32	25	170	37	32							
	MVJNR/L- 3232P16	32	32	170	37	32							

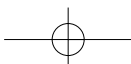

- C
- 01
- 02
- 03
- 04
- 05
- 06
- 07
- 08
- 09
- 10
- 11
- 12
- 13
- 14

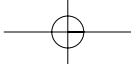

## 外徑車刀架系列/Tool Holders Series

**MVVN**  
72°30'

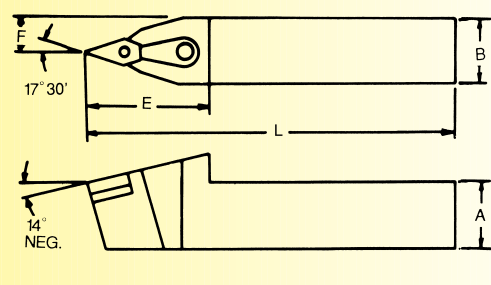

訂購編號 Style No.	產品型號 Model No.	部位尺寸 Dimensions(mm)					刀片 Insert	零件 Parts					訂價 (NT\$)
		A	B	L	E	F							
	MVVNN-2020K 16K	20	20	125	42	10.57	VNMG 16 04 08	SMV-322	LCS-513	CP50-25	CS70-22		
	MVVNN-2525M 16K	25	25	150	42	13.06	VNMG 16 04 08	SMV-322	LCS-513	CP50-25	CS70-22		
	MVVNN-3225P 16K	32	25	170	42	13.06	VNMG 16 04 08	SMV-322	LCS-513	CP50-25	CS70-22		
	MVVNN-3232P 16K	32	32	170	42	16	VNMG 16 04 08	SMV-322	LCS-513	CP50-25	CS70-22		
	MVVNR-2020K 16K	20	20	125	45	20	VNMG 16 04 08	SMV-322	LCS-513	CP50-25	CS70-22		
	MVVNR-2525M 16K	25	25	150	45	27	VNMG 16 04 08	SMV-322	LCS-513	CP50-25	CS70-22		

**MSB**  
75°

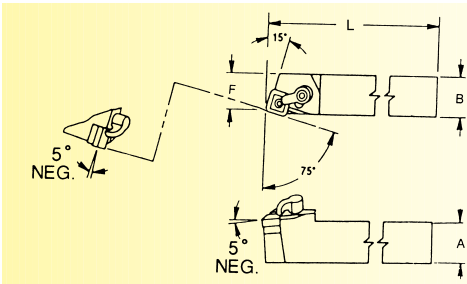

訂購編號 Style No.	產品型號 Model No.	部位尺寸 Dimensions(mm)				刀片 Insert	零件 Parts					訂價 (NT\$)
		A	B	L	F							
	MSBNR/L-2020K12	20	20	125	17	SN□□ 1204□□	SMS-432	LCS-617	CP50-22	CS70-22		
	MSBNR/L-2525M12	25	25	150	22		SMS-432	LCS-617	CP50-22	CS70-22		
	MSBNR/L-3225P12	32	25	170	22		SMS-432	LCS-617	CP50-22	CS70-22		

**MSK**  
75°

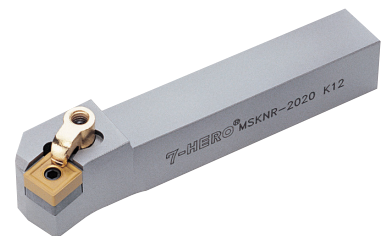
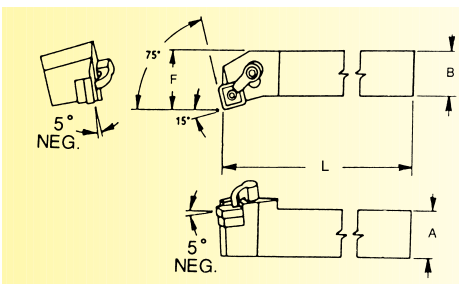

訂購編號 Style No.	產品型號 Model No.	部位尺寸 Dimensions(mm)				刀片 Insert	零件 Parts					訂價 (NT\$)
		A	B	L	F							
	MSKNR/L-2020K12	20	20	125	25	SN□□ 1204□□	SMS-432	LCS-617	CP50-22	CS70-22		
	MSKNR/L-2525M12	25	25	150	32		SMS-432	LCS-617	CP50-22	CS70-22		
	MSKNR/L-3225P12	32	25	170	32		SMS-432	LCS-617	CP50-22	CS70-22		

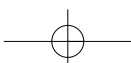

C  
01  
02  
03  
04  
05  
06  
07  
08  
09  
10  
11  
12  
13  
14

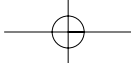

## 外徑車刀架系列/Tool Holders Series

**MSD  
45°**

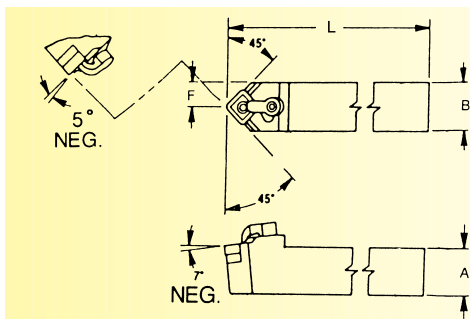

訂購編號 Style No.	產品型號 Model No.	部位尺寸 Dimensions(mm)				刀片 Insert	零件 Parts				訂價 (NT\$)
		A	B	L	F						
	MSDNN-2020K12	20	20	125	10.3	SN□□ 1204□□	SMS-432	LCS-617	CP50-22	CS70-22	
	MSDNN-2525M12	25	25	150	12.8		SMS-432	LCS-617	CP50-22	CS70-22	
	MSDNN-3225P12	32	25	170	12.8		SMS-432	LCS-617	CP50-22	CS70-22	

**MTGN  
90°**

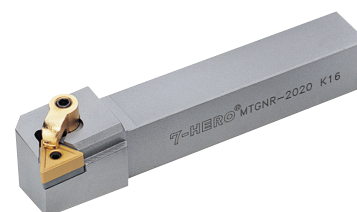
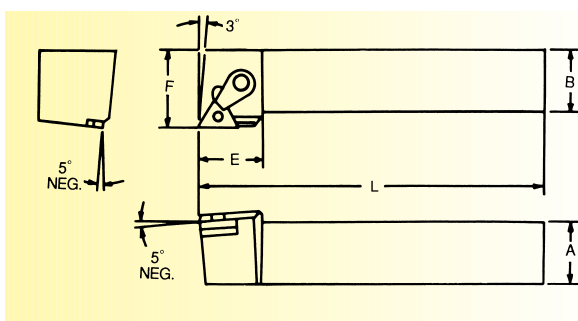

訂購編號 Style No.	產品型號 Model No.	部位尺寸 Dimensions(mm)					刀片 Insert	零件 Parts				訂價 (NT\$)
		A	B	L	E	F						
	MTGNN/L-1616H16	16	16	100	30	20	TNMG 16 04 08	SMT-322	LCS-513	CP50-22	CS70-22	
	MTGNN/L-2020K16	20	20	125	32	25	TNMG 16 04 08	SMT-322	LCS-513	CP50-22	CS70-22	
	MTGNN/L-2525M16	25	25	150	32	32	TNMG 16 04 08	SMT-322	LCS-513	CP50-22	CS70-22	

**MTJN  
93°**

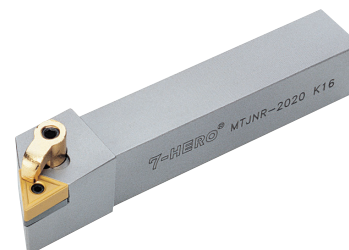
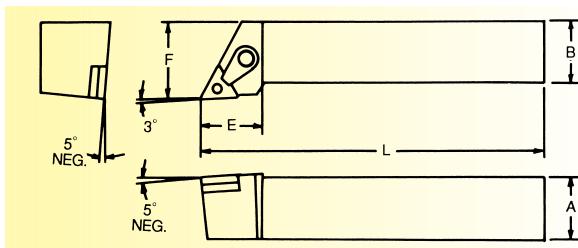

訂購編號 Style No.	產品型號 Model No.	部位尺寸 Dimensions(mm)					刀片 Insert	零件 Parts				訂價 (NT\$)
		A	B	L	E	F						
	MTJNN/L-1616H16	16	16	100	30	20	TNMG 16 04 08	SMT-322	LCS-513	CP50-22	CS70-22	
	MTJNN/L-2020K16	20	20	125	32	25	TNMG 16 04 08	SMT-322	LCS-513	CP50-22	CS70-22	
	MTJNN/L-2525M16	25	25	150	32	32	TNMG 16 04 08	SMT-322	LCS-513	CP50-22	CS70-22	
	MTJNN/L-3225P16	32	25	170	32	32	TNMG 16 04 08	SMT-322	LCS-513	CP50-22	CS70-22	
	MTJNN/L-3232P16	32	25	170	32	40	TNMG 16 04 08	SMT-322	LCS-513	CP50-22	CS70-22	

C  
01  
02  
03  
04  
05  
06  
07  
08  
09  
10  
11  
12  
13  
14

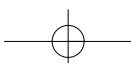

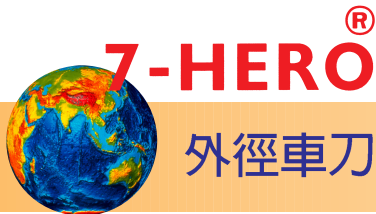
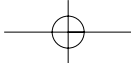

## 外徑車刀架系列/Tool Holders Series

### MTEN 60°

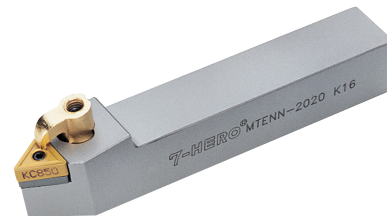
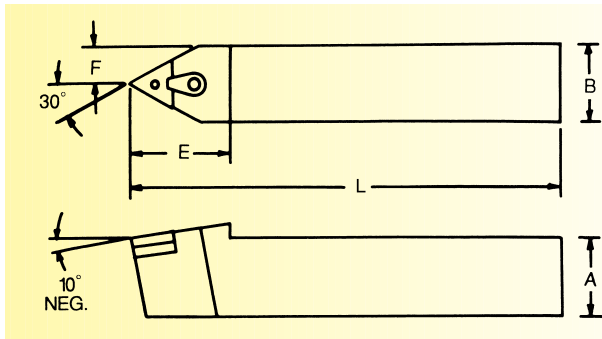

訂購編號 Style No.	產品型號 Model No.	部位尺寸 Dimensions(mm)					刀片 Insert	零件 Parts					訂價 (NT\$)
		A	B	L	E	F							
	MTENN-2020K16	20	20	125	32	10.46	TNGM 16 04 08	SMT-322	LCS-513	CP50-22	CS70-22		
	MTENN-2525M16	25	25	150	32	12.95	TNGM 16 04 08	SMT-322	LCS-513	CP50-22	CS70-22		
	MTENN-3225P16	32	25	170	32	12.5	TNGM 16 04 08	SMT-322	LCS-617	CP50-22	CS70-22		
	MTENN-3232P16	32	32	170	32	16	TNGM 16 04 08	SMT-322	LCS-617	CP50-22	CS70-22		
	MTENN-2525M22	25	25	150	35	12.5	TNGM 22 04 08	SMT-433	LCS-617	CP50-28	CS7-8030		
	MTENN-3225P22	32	25	170	35	12.5	TNGM 22 04 08	SMT-433	LCS-617	CP50-28	CS7-8030		
	MTENN-3232P22	32	32	170	35	16	TNGM 22 04 08	SMT-433	LCS-617	CP50-28	CS7-8030		

### MCLN 95°

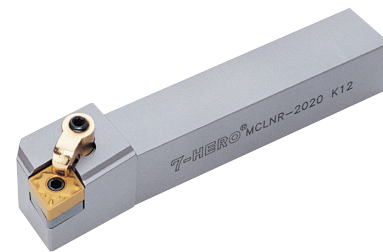
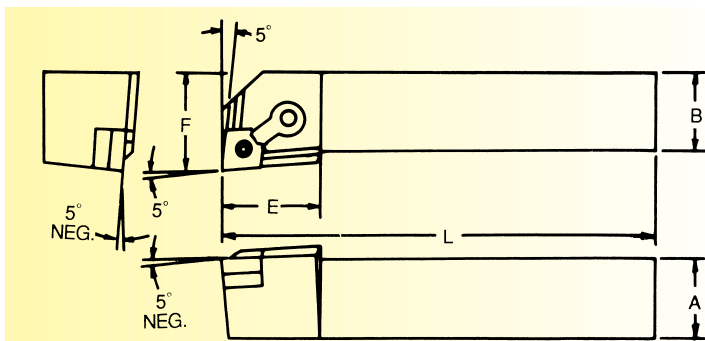

訂購編號 Style No.	產品型號 Model No.	部位尺寸 Dimensions(mm)					刀片 Insert	零件 Parts					訂價 (NT\$)
		A	B	L	E	F							
	MCLNR/L-1616H12	16	16	100	32	20	CNMG 12 04 08	SMC-432	LCS-617	CP50-22	CS70-22		
	MCLNR/L-2020K12	20	20	125	32	25	CNMG 12 04 08	SMC-432	LCS-617	CP50-22	CS70-22		
	MCLNR/L-2525M12	25	25	150	32	32	CNMG 12 04 08	SMC-432	LCS-617	CP50-22	CS70-22		
	MCLNR/L-3225P12	32	25	170	32	32	CNMG 12 04 08	SMC-432	LCS-617	CP50-22	CS70-22		
	MCLNR/L-3232P12	16	16	170	32	40	CNMG 12 04 0	SMC-432	LCS-617	CP50-22	CS70-22		
	MCLNR/L-2525P16	32	25	150	32	32	CNMG 16 06 08	SMC-533	LCS-0822	CP50-22	CS70-22		
	MCLNR/L-3225P16	25	25	170	32	32	CNMG 16 06 08	SMC-533	LCS-0822	CP50-22	CS70-22		
	MCLNR/L-3232P16	32	32	170	32	40	CNMG 16 06 08	SMC-533	LCS-0822	CP50-22	CS70-22		

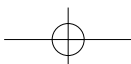

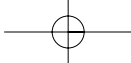

## 外徑車刀架系列/Tool Holders Series

**MCKN**  
75°

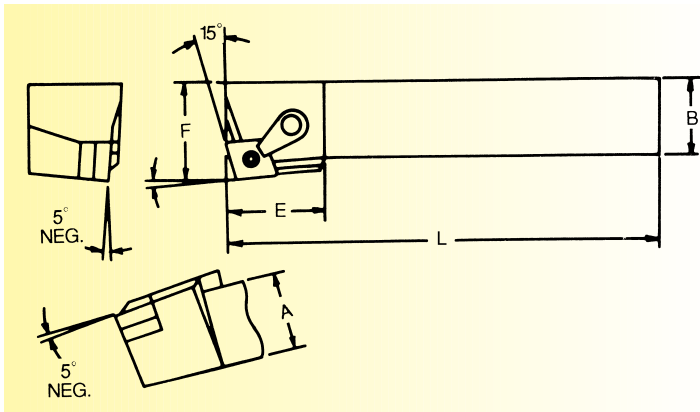

訂購編號 Style No.	產品型號 Model No.	部位尺寸 Dimensions(mm)					刀片 Insert	零件 Parts					訂價 (NT\$)
		A	B	L	E	F							
	MCKNR/L- 2020K12	20	20	125	32	25							
	MCKNR/L- 2525M12	25	25	150	32	32							
	MCKNR- 3225P12	32	25	170	32	32							
	MCKNR- 3232P12	32	32	170	32	40							

**MCRN**  
75°

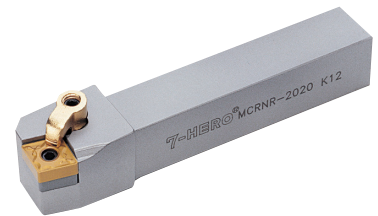
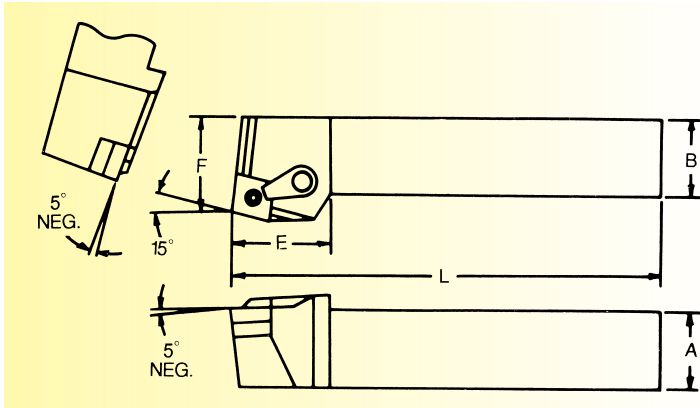

訂購編號 Style No.	產品型號 Model No.	部位尺寸 Dimensions(mm)					刀片 Insert	零件 Parts					訂價 (NT\$)
		A	B	L	E	F							
	MCRNR/L- 2020K12	20	20	125	32	25							
	MCRNR/L- 2525M12	25	25	150	32	32							
	MCRNR- 3225P12	32	25	170	32	32							
	MCRNR- 3232P12	32	32	170	32	40							

C  
01  
02  
03  
04  
05  
06  
07  
08  
09  
10  
11  
12  
13  
14

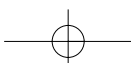

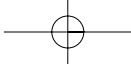

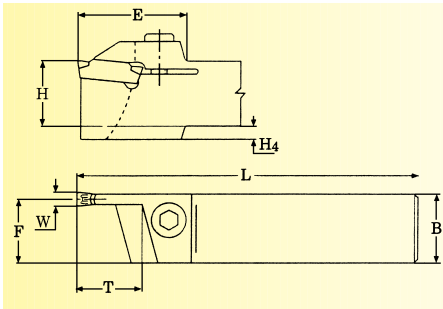

## 外徑車刀架系列/Tool Holders Series





C  
01  
02  
03  
04  
05  
06  
07  
08  
09  
10  
11  
12  
13  
14

- 可開槽、擴槽及外徑深加工等。
- 可切斷、修端面。
- Can be made grooving and enlarged also, so that for deep hole processing.
- Can be made cut off & end face dressing.

### 外徑深加工霸王刀刀架 / Chief Boring Bars for External Deep Turning

訂購編號 Style No.	產品型號 Model No.	部位尺寸 Dimensions(mm)				刀片 Insert	零件 Parts		訂價 (NT\$)
		H × B	L	T	W				
	GHGR-16-3	16 × 16	120	20	3	GIP-3	P-CS650-M	P-LW040-M	
	GHGR-20-2	20 × 20	120	20	2	GIP-2			
	GHGR-20-3	20 × 20	120	20	3	GIP-3			
	GHGR-20-4	20 × 20	120	20	4	GIP-4			
	GHGR-25-2	25 × 25	135	20	2	GIP-2			
	GHGR-25-3	25 × 25	135	20	3	GIP-3			
	GHGR-25-4	25 × 25	135	20	4	GIP-4			
	GHGR-25-5	25 × 25	135	20	5	GIP-5			

訂購編號 Style No.	產品型號 Model No.	部位尺寸 Dimensions(mm)				刀片 Insert	零件 Parts		訂價 (NT\$)
		H × B	L	T	W				
	GHDR12-3	12 × 12	120	8	3	GIP-3	P-CS650-M	P-LW040-M	
	GHDR16-4	16 × 16	120	10	4	GIP-4			
	GHDR20-3	20 × 20	120	9	3	GIP-3			
	GHDR20-4	20 × 20	120	10	4	GIP-4			
	GHDR20-5	20 × 20	135	12	5	GIP-5			
	GHDR25-3	25 × 25	135	9	3	GIP-3			
	GHDR25-4	25 × 25	135	10	4	GIP-4			
	GHDR25-5	25 × 25	135	12	5	GIP-5			
	KGMR1616K-3-20L	16 × 16	125	20	3	GMM3020	P-CS650-M	P-LW040-M	
	KGMR2020K-2-17L	20 × 20	125	17	2	GMM2020			
	KGMR2020K-3-10L	20 × 20	125	10	3	GMM3020			
	KGMR2020K-3-20L	20 × 20	125	20	3	GMM3020			
	KGMR2020K-3-20XL	20 × 20	125	20	3	GMM3020			
	KGMR2020K-4-10L	20 × 20	125	10	4	GMM4020			
	KGMR2020K-4-20L	20 × 20	125	20	4	GMM4020			
	KGMR2525K-2-17L	25 × 25	140	17	2	GMM2020			
	KGMR2525K-3-10L	25 × 25	140	10	3	GMM3020			
	KGMR2525K-3-20L	25 × 25	140	20	3	GMM3020			
	KGMR2525K-3-20XL	25 × 25	140	20	3	GMM3020			
	KGMR2525K-4-10L	25 × 25	140	10	4	GMM4020			
	KGMR2525K-4-20L	25 × 25	140	20	4	GMM4020			
	KGMR2525K-4-20XL	25 × 25	140	20	4	GMM4020			

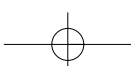

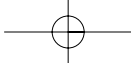

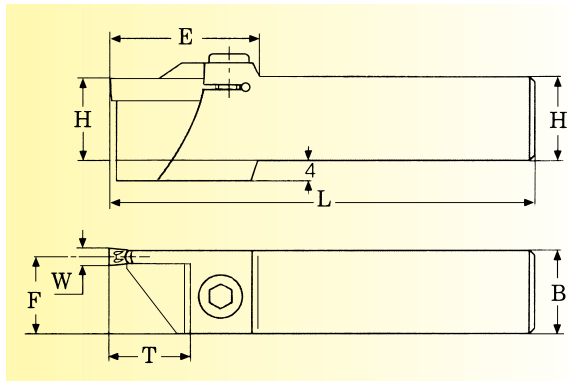

## 外徑車刀架系列/Tool Holders Series



### 外徑切斷刀刀架 / Tool Holders for External Cutting off

訂購編號 Style No.	產品型號 Model No.	部位尺寸 Dimensions(mm)				刀片 Insert 	零件 Parts  		訂價 (NT\$)		
		W	H×B	L	T						
	DGTR-10B-2D-15	2	10×10	120	15	DGN	P-CS650-M	P-LW040-M			
	DGTR-12B-2D-15	2	12×12	120	15						
	DGTR-12B-3D-15	3	12×12	120	15						
	DGTR-16B-2D-16	2	16×16	120	16						
	DGTR-16B-3D-16	3	16×16	120	16						
	DGTR-20B-2D-18	2	20×20	125	18						
	DGTR-20B-3D-20	3	20×20	125	20						
	DGTR-20B-4D-20	4	20×20	125	20						
	DGTR-25B-2D-18	2	25×25	140	18						
	DGTR-25B-3D-20	3	25×25	140	20						
	DGTR-25B-4D-25	4	25×25	140	25						
	DGHR-1616K-3-16L	3	16×16	125	16	DGM30CT	P-CS650-M	P-LW040-M			
	DGHR-2020K-3-20L	3	20×20	125	20	DGM30CT					
	DGHR-2020K-3-20XL	3	20×20	125	20	DGM30CT					
	DGHR-2020K-3-25AL	3	20×20	125	25	DGJ30CE					
	DGHR-2020K-3-25L	3	20×20	125	25	DGM30CE					
	DGHR-2020K-4-20L	4	20×20	125	20	DGM40CT					
	DGHR-2020K-4-20XL	4	20×20	125	20	DGM40CT					
	DGHR-2020K-4-25AL	4	20×20	125	25	DGJ40CE					
	DGHR-2020K-4-25L	4	20×20	125	25	DGM40CE					
	DGHR-2020K-5-25AL	5	20×20	125	25	DGJ50CE					
	DGHR-2020K-5-25L	5	20×20	125	25	DGM50CT					
	DGHR-2525M-3-20L	3	25×25	140	20	DGM30CT			P-CS650-M	P-LW040-M	
	DGHR-2525M-3-20XL	3	25×25	140	20	DGM30CT					
	DGHR-2525M-3-25AL	3	25×25	140	25	DGJ30CE					
	DGHR-2525M-3-25L	3	25×25	140	25	DGM30CE					
	DGHR-2525M-4-20L	4	25×25	140	20	DGM40CT					
	DGHR-2525M-4-20XL	4	25×25	140	20	DGM40CT					
	DGHR-2525M-4-25AL	4	25×25	140	25	DGJ40CE					
	DGHR-2525M-4-25L	4	25×25	140	25	DGM40CE					
	DGHR-2525M-5-25AL	5	25×25	140	25	DGJ50CE					
	DGHR-2525M-5-25L	5	25×25	140	25	DGM50CT					
	KGAR-2020K-3-20L	3	20×20	125	20	GA30	P-CS650-M	P-LW040-M			
	KGAR-2020K-4-20L	4	20×20	125	20	GA40					
	KGAR-2525M-3-20L	3	25×25	140	20	GA30					
	KGAR-2525M-4-20L	4	25×25	140	20	GA40					

C

- 01
- 02
- 03
- 04
- 05
- 06
- 07
- 08
- 09
- 10
- 11
- 12
- 13
- 14

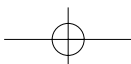

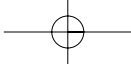

## 外徑車刀架系列/Tool Holders Series

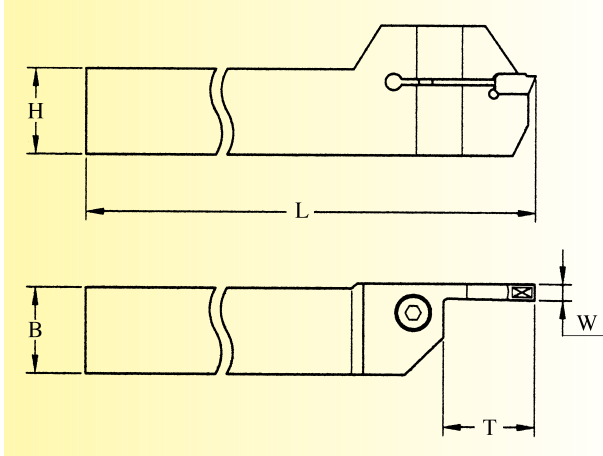

C  
01  
02  
03  
04  
05  
06  
07  
08  
09  
10  
11  
12  
13  
14

### 外徑切斷刀刀架 / Tool Holders for External Cutting off

訂購編號 Style No.	產品型號 Model No.	部位尺寸 Dimensions(mm)				刀片 Insert	零件 Parts		訂價 (NT\$)		
		W	H×B	L	T						
	KTKHR-2020K-2	2	20×20	125	20	TKN2	P-CS650-M	P-LW040-M			
	KTKHR-2525M-2	2	25×25	150	20						
	KTKHR-2020K-3	3	20×20	125	22	TKN3					
	KTKHR-2525M-3	3	25×25	150	22						
	A3SCR-1212X02-10L	2.2	12×12	130	10	3.90022	CS40	T-15			
	A3SCR-1616K02-16L	2.2	16×16	125	16	3.90022	P-CS650-M	P-LW040-M			
	A3SCR-1616K03-16L	3	16×16	125	16	3.90030					
	A3SCR-2020K01-16L	1.6	20×20	125	16	3.90016					
	A3SCR-2020K02-16L	2.2	20×20	125	16	3.90022					
	A3SCR-2020K03-16L	3	20×20	125	16	3.90030					
	A3SCR-2020K03-26L	3	20×20	125	26	3.90030					
	A3SCR-2525M02-16L	2.2	25×25	150	16	3.90022					
	A3SCR-2525M02-26L	2.2	25×25	150	26	3.90022					
	A3SCR-2525M03-16L	3	25×25	150	16	3.90030					
	A3SCR-2525M03-26L	3	25×25	150	26	3.90030					
	KGSPR-1212M2.4-14L	2.4	12×12	125	14	GS-2.4N			P-CS650-M	P-LW040-M	
	KGSPR-1616K2.4-20L	2.4	16×16	130	20	GS-2.4N					
	KGSPR-1616K3.2-20L	3.2	16×16	125	20	GS-3.2N					
	KGSPR-2020K2.4-20L	2.4	20×20	125	20	GS-2.4N					
	KGSPR-2020K3.2-20L	3.2	20×20	125	20	GS-3.2N					
	KGSPR-2525M2.4-25L	2.4	25×25	150	25	GS-2.4N					
	KGSPR-2525M3.2-25L	3.2	25×25	150	25	GS-3.2N					
	RF151.23-2020-3-20L	3	20×20	125	20	N151.2-30	P-CS650-M	P-LW040-M			
	RF151.23-2020-3-20XL	3	20×20	125	20	N151.2-40					
	RF151.23-2020-4-20L	4	20×20	125	20	N151.2-40					
	RF151.23-2525-3-20L	3	25×25	150	20	N151.2-30					
	RF151.23-2525-3-20XL	3	25×25	150	20	N151.2-30					
	RF151.23-2525-3-25L	3	25×25	150	25	N151.2-30					
	RF151.23-2525-4-20L	4	25×25	150	20	N151.2-40					
	RF151.23-2525-4-25L	4	25×25	150	25	N151.2-40					

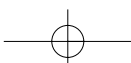

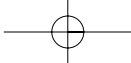

## 外徑車刀架系列/Tool Holders Series

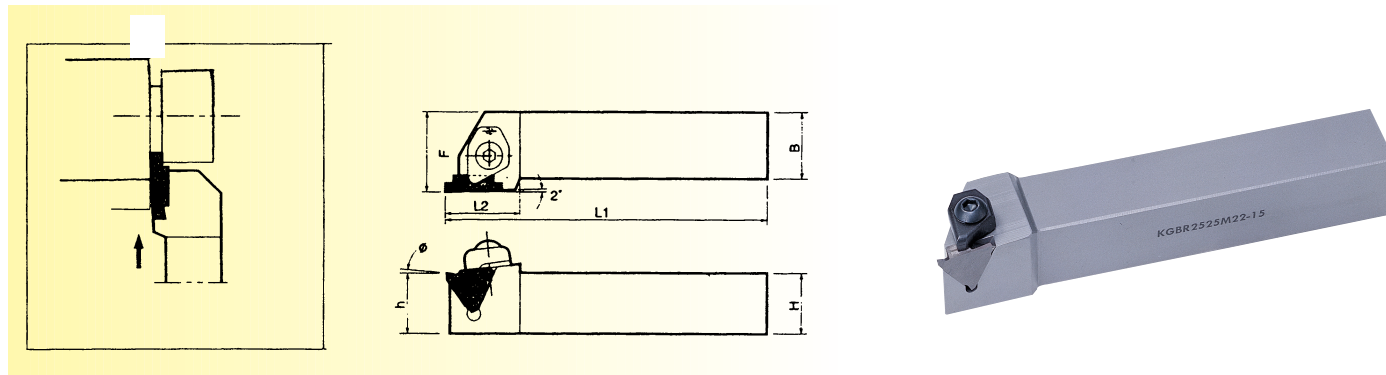

### 外徑開槽刀架 / External Groove Tooling Holder

訂購編號 Style No.	產品型號 Model No.	部位尺寸 Dimensions(mm)					刀片 Insert	零件 Parts					訂價 (NT\$)
		H=h	B	L1	L2	F							
	KGBR2020K22-15	20	20	125	25.5	25	GB43R125~230	CGBR/L	BH6 × 25	SP- 6	P-LW040-M		
	KGBR2525M22-15	25	25	150	25.5	30							
	KGBR2020K22-25	20	20	125	25.5	25	GB43R250~330	CGBR/L	BH6 × 25	SP- 6	P-LW040-M		
	KGBR2525M22-25	25	25	150	25.5	30							
	KGBR2020K22-35	20	20	125	25.5	25	GB43R350~480	CGBR/L	BH6 × 25	SP- 6	P-LW040-M		
	KGBR2525M22-35	25	25	150	25.5	30							

◎SUITABLE: KEYOCERA INSERT

### SER

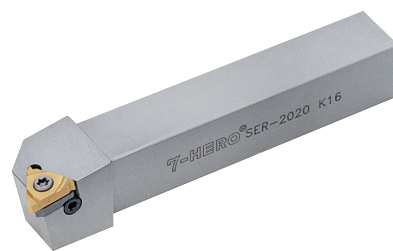
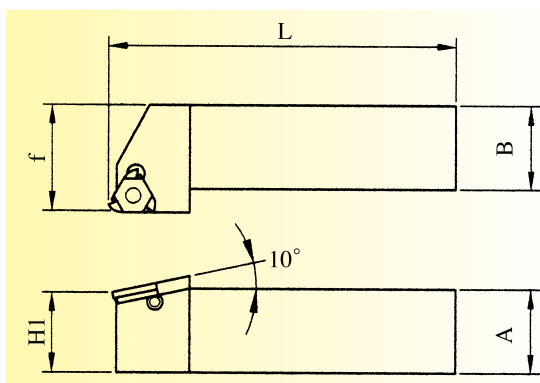
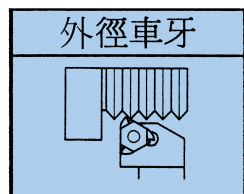

訂購編號 Style No.	產品型號 Model No.	部位尺寸 Dimensions(mm)					刀片 Insert	零件 Parts					訂價 (NT\$)
		L	A	B	H <sub>1</sub>	f							
	SER/L- 1616H- 16	100	16	16	16	20	16ER/L	AE16	AI16	CS35115	CS6- 0306	T- 15	
	SER/L- 2020K- 16	125	20	20	20	25							
	SER/L- 2525M- 16	150	25	25	25	32							
	SER/L- 3232P- 16	170	32	32	32	40							

C  
01  
02  
03  
04  
05  
06  
07  
08  
09  
10  
11  
12  
13  
14

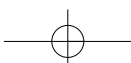

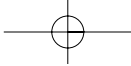

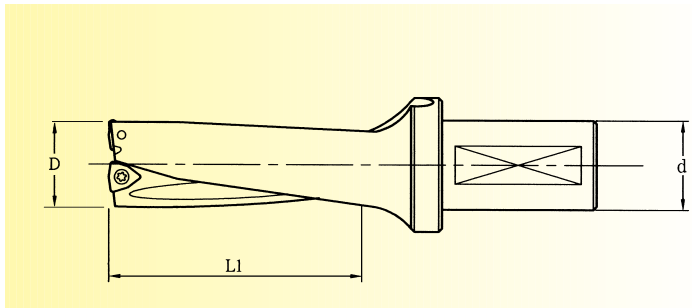

## 捨棄式快速鑽頭/Rapid Drills(W) Throw-Away Insert

D  
01  
02  
03  
04  
05  
06  
07



### 捨棄式快速鑽頭 / Rapid Drills(W) Throw-Away Insert

訂購編號 Style No.	產品型號 Model No.	部位尺寸 Dimensions(mm)			刀片 Insert	零件 Parts		訂價 (NT\$)
		D	L <sub>1</sub> (D×2)	d				
	14WCMX	14	28	25	 WCMX 030208	CS25	T8	
	15WCMX	15	30					
	16WCMX	16	32					
	17WCMX	17	34					
	18WCMX	18	36					
	19WCMX	19	38					
	20WCMX	20	40					
	21WCMX	21	42					
	22WCMX	22	44					
	23WCMX	23	46					
	24WCMX	24	48					

訂購編號 Style No.	產品型號 Model No.	部位尺寸 Dimensions(mm)			刀片 Insert	零件 Parts		訂價 (NT\$)
		D	L <sub>1</sub> (D×3)	d				
	14WCMX	14	42	25	 WCMX 030208	CS25	T8	
	15WCMX	15	45					
	16WCMX	16	48					
	17WCMX	17	51					
	18WCMX	18	54					
	19WCMX	19	57					
	20WCMX	20	60					
	21WCMX	21	63					
	22WCMX	22	66					
	23WCMX	23	69					
	24WCMX	24	72					

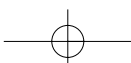

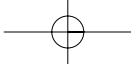

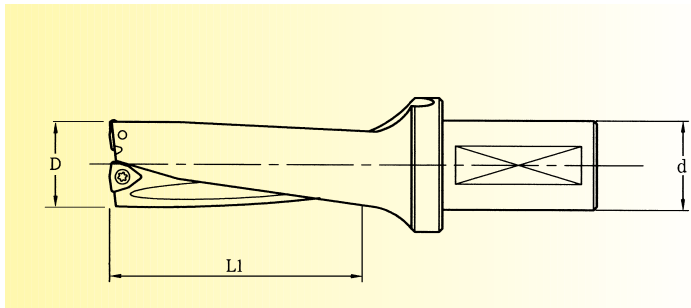

## 捨棄式快速鑽頭/Rapid Drills(W) Throw-Away Insert



D  
01  
02  
03  
04  
05  
06  
07

### 捨棄式快速鑽頭 / Rapid Drills(W) Throw-Away Insert

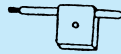
訂購編號 Style No.	產品型號 Model No.	部位尺寸 Dimensions(mm)			刃片 Insert 	零件 Parts  		訂價 (NT\$)
		D	L <sub>1</sub> (D×2)	d				
	14WCMX	14	28	32	WCMX 030208	CS25	T8	
	15WCMX	15	30					
	16WCMX	16	32					
	17WCMX	17	34					
	18WCMX	18	36					
	19WCMX	19	38					
	20WCMX	20	40					
	21WCMX	21	42					
	22WCMX	22	44					
	23WCMX	23	46					
	24WCMX	24	48					
	25WCMX	25	50					
	26WCMX	26	52					
	27WCMX	27	54					
	28WCMX	28	56					
	29WCMX	29	58					
	30WCMX	30	60					
	31WCMX	31	62					
	32WCMX	32	64					
	33WCMX	33	66					
	34WCMX	34	68					
	35WCMX	35	70					
	36WCMX	36	72					
	37WCMX	37	74					
					WCMX 050308	CS30	T10	
					WCMX 06T308	CS35	T15	

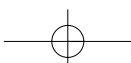

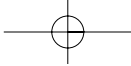

## 捨棄式快速鑽頭/Rapid Drills(W) Throw-Away Insert

D  
01  
02  
03  
04  
05  
06  
07

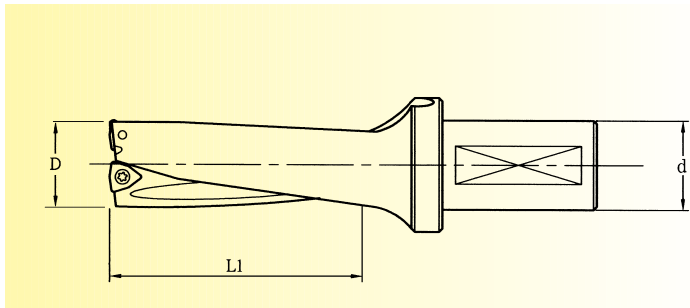

### 捨棄式快速鑽頭 / Rapid Drills(W) Throw-Away Insert

訂購編號 Style No.	產品型號 Model No.	部位尺寸 Dimensions(mm)			刃片 Insert	零件 Parts		訂價 (NT\$)
		D	L <sub>1</sub> (D×2)	d				
	38WCMX	38	76	40	WCMX 06T308	CS35	T15	
	39WCMX	39	78					
	40WCMX	40	80					
	41WCMX	41	82					
	42WCMX	42	84					
	43WCMX	43	86		WCMX 080408	CS40		
	44WCMX	44	88					
	45WCMX	45	90					
	46WCMX	46	92					
	47WCMX	47	94					
	48WCMX	48	96					
	49WCMX	49	98					
	50WCMX	50	100					
	51WCMX	51	102					
	52WCMX	52	104					
	53WCMX	53	106		WCMX 06T308 4片刃片 (W) four inserts	CS35		
	54WCMX	54	108					
	55WCMX	55	110					
	56WCMX	56	112					
	57WCMX	57	114					
	58WCMX	58	116					
	59WCMX	59	118					
	60WCMX	60	120					
	61WCMX	61	122					
	62WCMX	62	124					
	63WCMX	63	126					
	64WCMX	64	128					

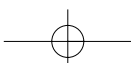

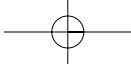

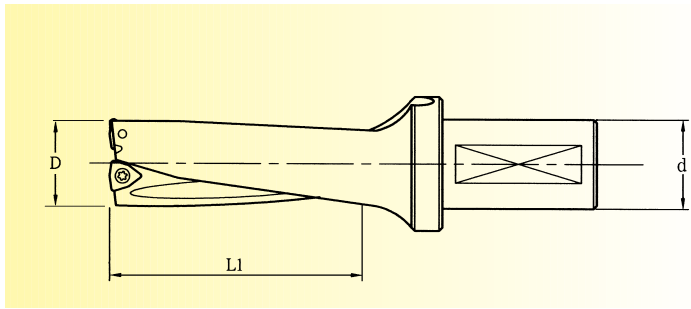

## 捨棄式快速鑽頭/Rapid Drills(W) Throw-Away Insert



D  
01  
02  
03  
04  
05  
06  
07

### 捨棄式快速鑽頭 / Rapid Drills(W) Throw-Away Insert

訂購編號 Style No.	產品型號 Model No.	部位尺寸 Dimensions(mm)			刀片 Insert	零件 Parts		訂價 (NT\$)
		D	L <sub>1</sub> (D×3)	d				
	14WCMX	14	42	32	WCMX 030208	CS25	T8	
	15WCMX	15	45					
	16WCMX	16	48					
	17WCMX	17	51					
	18WCMX	18	54					
	19WCMX	19	57					
	20WCMX	20	60					
	21WCMX	21	63					
	22WCMX	22	66					
	23WCMX	23	69					
	24WCMX	24	72					
	25WCMX	25	75					
	26WCMX	26	78					
	27WCMX	27	81					
	28WCMX	28	84					
	29WCMX	29	87					
	30WCMX	30	90					
	31WCMX	31	93					
	32WCMX	32	96					
	33WCMX	33	99					
	34WCMX	34	102					
	35WCMX	35	105					
	36WCMX	36	108					
	37WCMX	37	111					
	38WCMX	38	114	40	WCMX 06T308	CS35	T15	
	39WCMX	39	117					
	40WCMX	40	120					

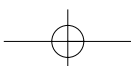

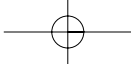

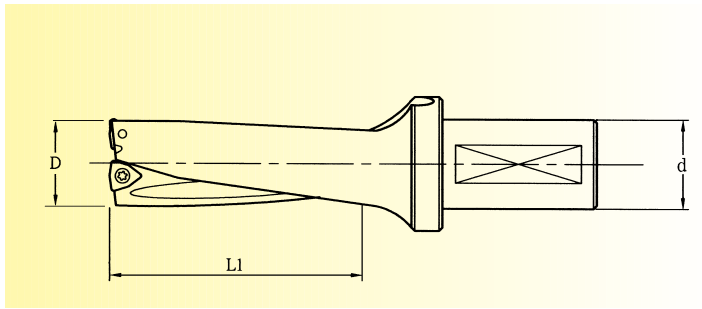

## 捨棄式快速鑽頭/Rapid Drills(W) Throw-Away Insert

D  
01  
02  
03  
04  
05  
06  
07



### 捨棄式快速鑽頭 / Rapid Drills(W) Throw-Away Insert

訂購編號 Style No.	產品型號 Model No.	部位尺寸 Dimensions(mm)			刀片 Insert	零件 Parts		訂價 (NT\$)
		D	L1 (D×3)	d				
	41WCMX	41	123	40	WCMX 06T308	CS35	T15	
	42WCMX	42	126					
	43WCMX	43	129					
	44WCMX	44	132					
	45WCMX	45	135					
	46WCMX	46	138					
	47WCMX	47	141		WCMX 080412	CS40		
	48WCMX	48	144					
	49WCMX	49	147					
	50WCMX	50	150					
	51WCMX	51	153					
	52WCMX	52	156					
	53WCMX	53	159		WCMX 06T308 4片刀片 (W) four inserts	CS35		
	54WCMX	54	162					
	55WCMX	55	165					
	56WCMX	56	168					
	57WCMX	57	171					
	58WCMX	58	174					
	59WCMX	59	177					
	60WCMX	60	180					
	61WCMX	61	183					
	62WCMX	62	186					
	63WCMX	63	189					
	64WCMX	64	192					

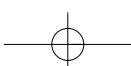

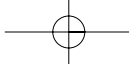

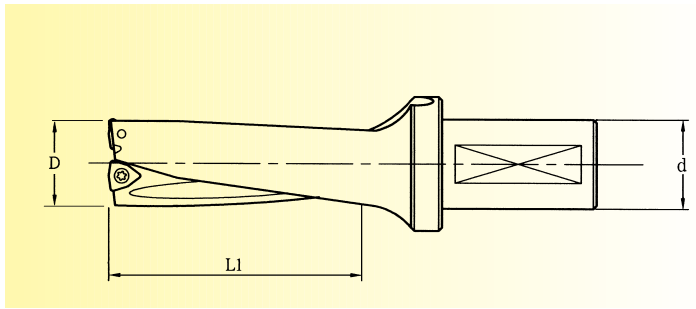

## 捨棄式快速鑽頭/Rapid Drills(W) Throw-Away Insert



D  
01  
02  
03  
04  
05  
06  
07

## 捨棄式快速鑽頭 / Rapid Drills(W) Throw-Away Insert

訂購編號 Style No.	產品型號 Model No.	部位尺寸 Dimensions(mm)			刀片 Insert 	零件 Parts  		訂價 (NT\$)
		D	L <sub>1</sub> (D×4)	d				
	14WCMX	14	56	32	WCMX 030208	CS25	T8	
	16WCMX	16	64					
	19WCMX	19	76					
	20WCMX	20	80					
	21WCMX	21	84					
	22WCMX	22	88					
	23WCMX	23	92					
	24WCMX	24	96					
	25WCMX	25	100					
	26WCMX	26	104					
	27WCMX	27	108	40	WCMX 050308	CS30	T10	
	28WCMX	28	112					
	29WCMX	29	120					
	34WCMX	34	136					
	39WCMX	39	156					
	41WCMX	41	164					
	43WCMX	43	172					
	44WCMX	44	176					
	47WCMX	47	188					
	50WCMX	50	200					
	54WCMX	54	216	WCMX 080412	CS40	T15		
	59WCMX	59	236					
					WCMX 06T308	CS35	T15	

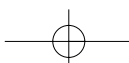

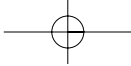



## 捨棄式快速鑽頭/Rapid Drills(W) Throw-Away Insert

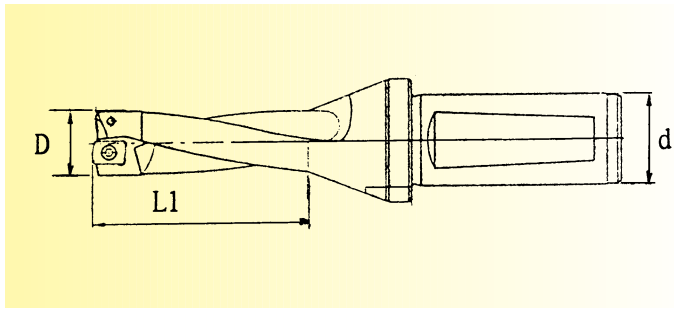

D  
01  
02  
03  
04  
05  
06  
07



- 小徑鑽孔、鋼性強、切削效率高。
- Small drilling bore, rugged & hi cutting efficiency.

### 捨棄式快速鑽頭 / Rapid Drills(W) Throw-Away Insert

訂購編號 Style No.	產品型號 Model No.	部位尺寸 Dimensions(mm)			刀片 Insert 	零件 Parts 		訂價 (NT\$)
		D	L1 (D×2)	d				
	12.5DFR	12.5	25	25	DFR 020204	CS20	T6	
	13DFR	13	26					
	13.5DFR	13.5	27					
	14DFR	14	28					
	14.5DFR	14.5	29					
	15DFR	15	30					
	15.5DFR	15.5	31					
	16DFR	16	32					

訂購編號 Style No.	產品型號 Model No.	部位尺寸 Dimensions(mm)			刀片 Insert 	零件 Parts 		訂價 (NT\$)
		D	L1 (D×3)	d				
	12.5DFR	12.5	38	25	DFR 020204	CS20	T6	
	13DFR	13	39					
	13.5DFR	13.5	41					
	14DFR	14	42					
	14.5DFR	14.5	44					
	15DFR	15	45					
	15.5DFR	15.5	47					
	16DFR	16	48					

©SUITABLE: KENNAMETAL INSERT

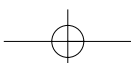



**ADONAI**®

## ROTARY BROACING TOOLS 迴轉沖削刀具

專利  
PATENT



- **ADONAI** 轉削孔刀具可製作六角孔、四角孔、星形孔、異形孔或其他特殊外形。

The **ADONAI** broaching tools can produce hexagonal and square holes, can also produce Torx and other special internal and external forms.

- **ADONAI** 轉削孔刀具適用於一般車床、CNC自動車床、綜合加工機、鑽床等。

The **ADONAI** broaching tools can also be used on lathes, CNC automatic lathes, machine centers, drilling machines.



主上工業股份有限公司  
PRAISE PRECISION IND.CO.,LTD.



ADONAI®

KNURLING TOOLS

滾花刀系列  
(車花、壓花)

專利  
PATENT



7-HERO®

七豪牌

主上工業股份有限公司  
PRAISE PRECISION IND.CO.,LTD.

7-HERO®

七豪牌

GROOVING TOOLS

切槽刀具系列

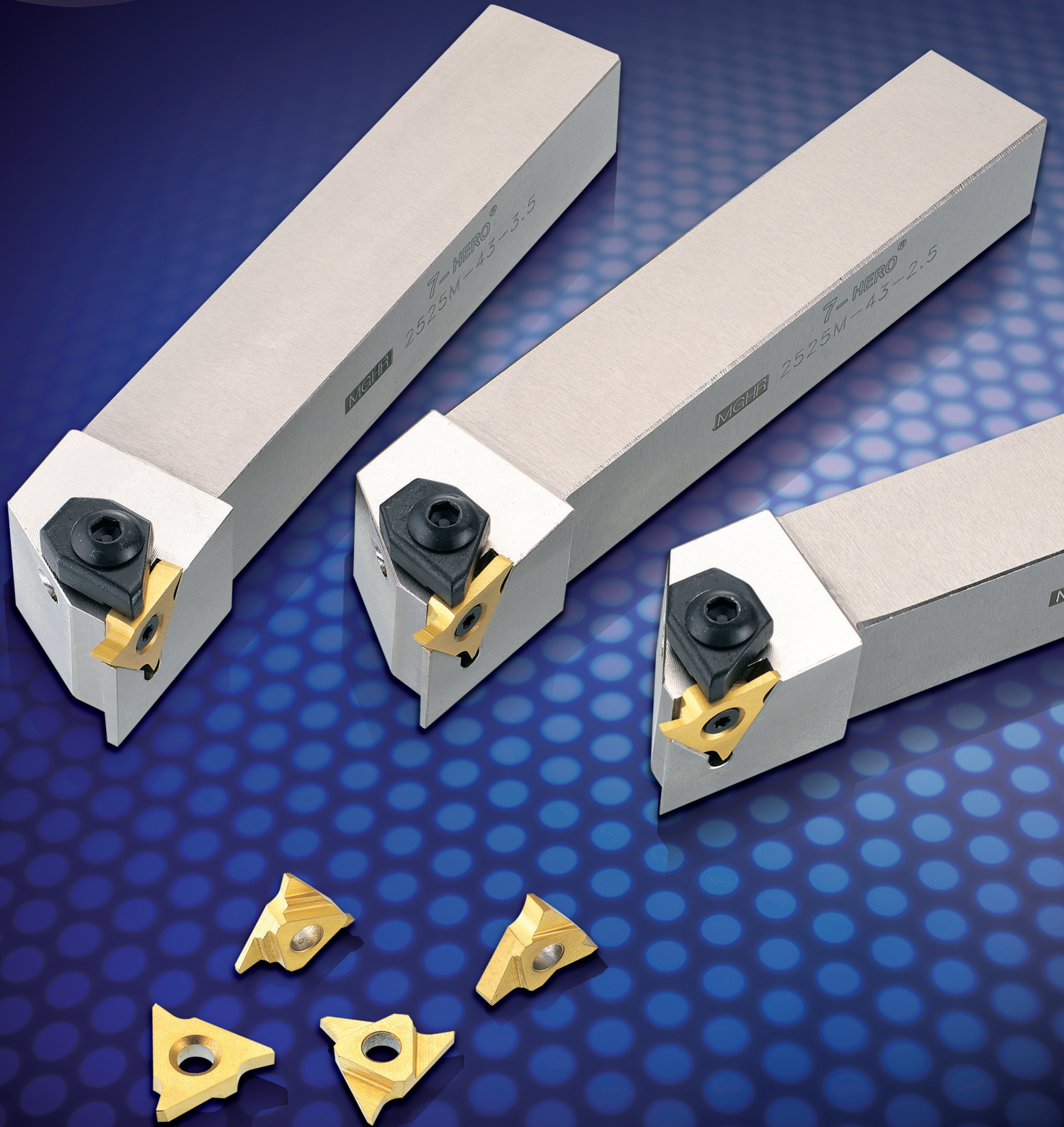

主上工業股份有限公司  
PRAISE PRECISION IND. CO., LTD.

7-HERO®

七豪牌

SOLID CENTER OF  
CARBIDE TIPPED  
鎢鋼頂針



主上工業股份有限公司  
PRAISE PRECISION IND. CO., LTD.

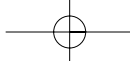

# 防震超微粒鎢鋼柄小徑搪刀架

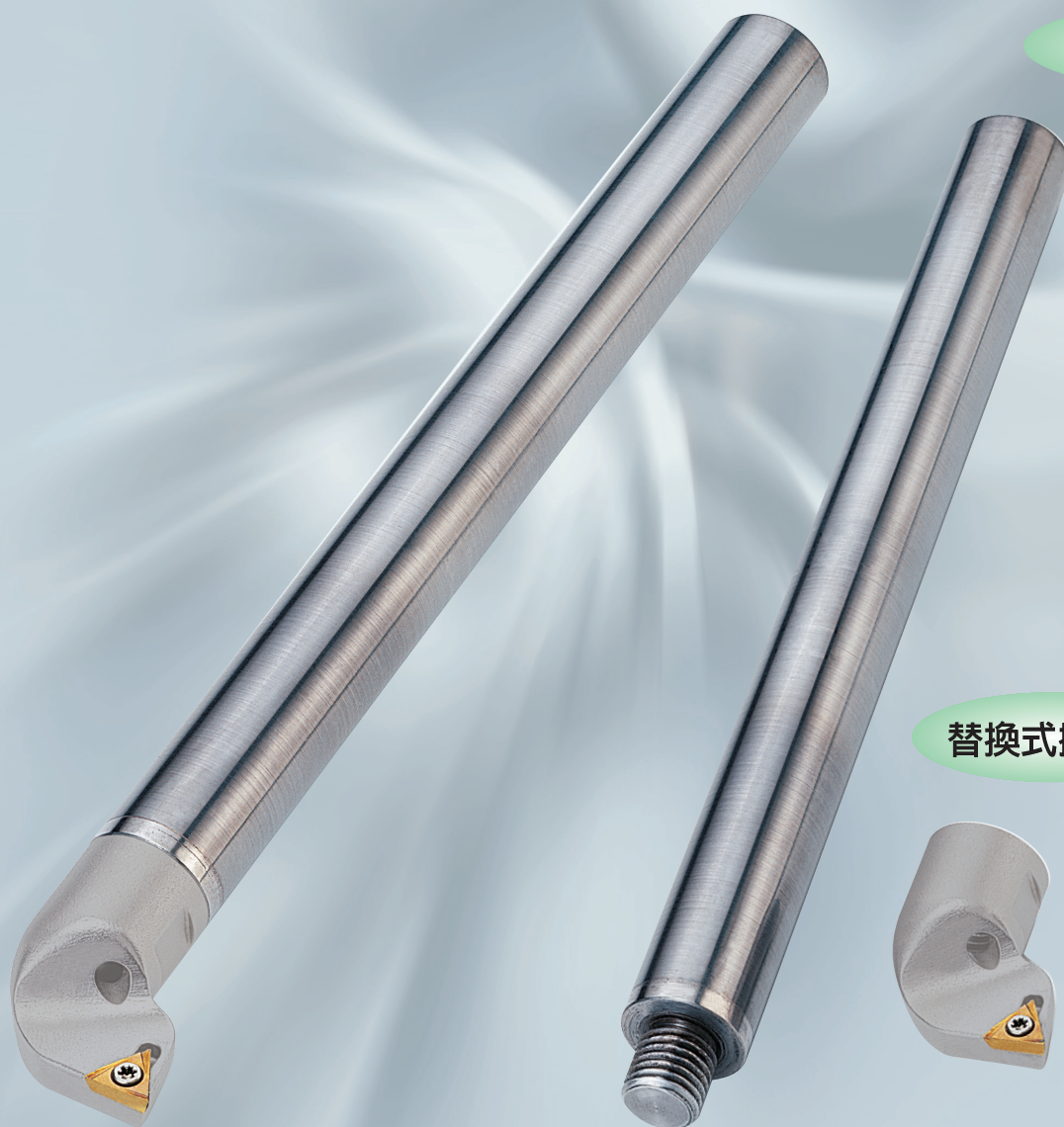

鎢鋼柄小徑搪刀桿

替換式搪刀頭



- 防震、鋼性超強  
(適合小徑深孔、精加工)
- 搪孔範圍從 $\phi 9\text{m/m}$ ~ $\phi 40\text{m/m}$
- 柄徑  $\phi 8$ 、 $\phi 10$ 、 $\phi 12$ 、 $\phi 16$   
規格齊全，價格公道

