

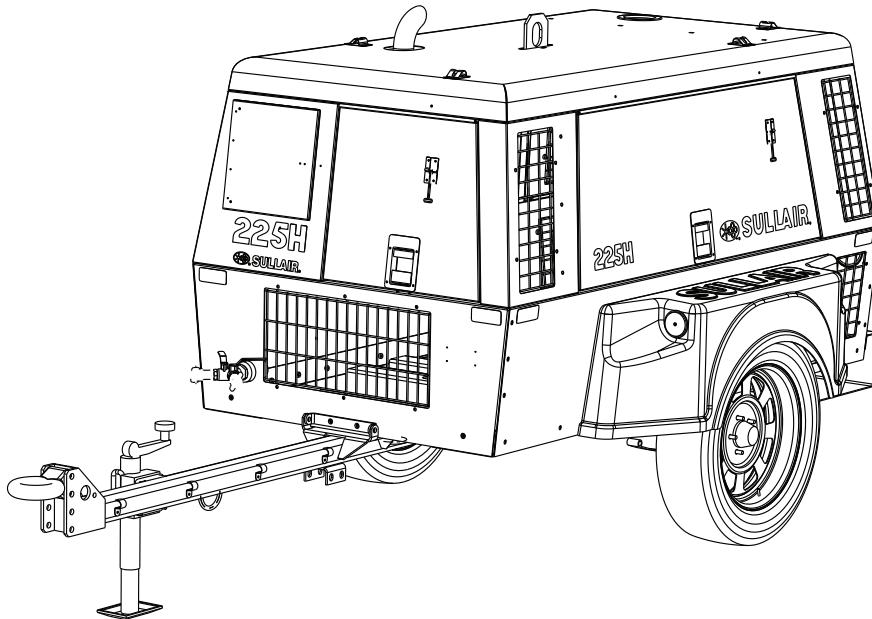

USER MANUAL

PORTABLE AIR COMPRESSOR 225H AND 260

CATERPILLAR, DEUTZ AND JOHN DEERE



WARRANTY NOTICE

Failure to follow the instructions
and procedures in this manual or,
misuse of this equipment will
VOID its warranty!

PART NUMBER:
02250177-848 R00

**KEEP FOR
FUTURE
REFERENCE**

©SULLAIR CORPORATION

The information in this manual is current
as of its publication date, and applies to
compressor **serial number:**

200812090000

and all subsequent serial numbers.



AIR CARE SEMINAR TRAINING

Sullair Air Care Seminars are courses that provide hands-on instruction for the proper operation, maintenance, and servicing of Sullair products. Individual seminars on portable compressors and compressor electrical systems are offered at regular intervals throughout the year at Sullair's corporate headquarters training facility located at Michigan City, Indiana.

Instruction includes training on the function and installation of Sullair service parts, troubleshooting common faults and malfunctions, and actual equipment operation. These seminars are recommended for maintenance, contractor maintenance, and service personnel.

For detailed course outlines, schedule, and cost information contact:

SULLAIR CUSTOMER CARE TRAINING DEPARTMENT

1-888-SULLAIR or
219-879-5451 (ext. 5623)
www.sullair.com

- Or Write -

Sullair Corporation
3700 E. Michigan Blvd.
Michigan City, IN 46360
Attn: Service Training Department.



TABLE OF CONTENTS

SECTION 1—SAFETY

3	1.1	GENERAL
3	1.2	TOWING
6	1.3	PRESSURE RELEASE
7	1.4	FIRE AND EXPLOSION
8	1.5	MOVING PARTS
9	1.6	HOT SURFACES, SHARP EDGES AND SHARP CORNERS
9	1.7	TOXIC AND IRRITATING SUBSTANCES
10	1.8	ELECTRICAL SHOCK
10	1.9	LIFTING
10	1.10	ENTRAPMENT
11	1.11	JUMP STARTING
12	1.12	IMPLEMENTATION OF LOCKOUT/TAGOUT
13	1.13	CALIFORNIA PROPOSITION 65
14	1.14	SYMBOLS AND REFERENCES

SECTION 2—DESCRIPTION

17	2.1	INTRODUCTION
17	2.2	DESCRIPTION OF COMPONENTS
19	2.3	SULLAIR COMPRESSOR UNIT, FUNCTIONAL DESCRIPTION
19	2.4	COMPRESSOR COOLING AND LUBRICATION SYSTEM, FUNCTIONAL DESCRIPTION
20	2.5	COMPRESSOR DISCHARGE SYSTEM, FUNCTIONAL DESCRIPTION
21	2.6	CAPACITY CONTROL SYSTEM, FUNCTIONAL DESCRIPTION
24	2.7	PIPING AND INSTRUMENTATION—COMPRESSOR SYSTEM
26	2.8	PIPING AND INSTRUMENTATION—ENGINE SYSTEM
28	2.9	AIR INLET SYSTEM, FUNCTIONAL DESCRIPTION
29	2.10	INSTRUMENT PANEL GROUP, FUNCTIONAL DESCRIPTION
31	2.11	WIRING DIAGRAM—JD & DEUTZ
32	2.12	WIRING DIAGRAM—CAT
33	2.13	ELECTRICAL SYSTEM, FUNCTIONAL DESCRIPTION
33	2.14	COMPRESSOR SHUTDOWN & WARNING SYSTEM, FUNCTIONAL DESCRIPTION

TABLE OF CONTENTS

SECTION 3—SPECIFICATIONS

35	3.1	SPECIFICATIONS – 225H AND 260 JOHN DEERE
37	3.2	SPECIFICATIONS – 225H AND 260 DEUTZ
39	3.3	SPECIFICATIONS—225H AND 260 CATERPILLAR
40	3.4	LUBRICATION GUIDE – COMPRESSOR
41	3.5	APPLICATION GUIDE
41	3.6	LUBRICATION GUIDE – ENGINE

SECTION 4—GENERAL

43	4.1	GENERAL
43	4.2	PURPOSE OF CONTROLS
44	4.3	INITIAL STARTUP/SHUTDOWN PROCEDURE
45	4.4	RESTART PROCEDURE

SECTION 5—MAINTENANCE

47	5.1	GENERAL
47	5.2	ENGINE COOLANT REQUIREMENT FOR RADIATORS
47	5.3	DAILY MAINTENANCE
47	5.4	MAINTENANCE AFTER INITIAL 50 HOURS OF OPERATION
48	5.5	MAINTENANCE EVERY 50 HOURS
48	5.6	MAINTENANCE EVERY 100 HOURS
48	5.7	MAINTENANCE EVERY 250 HOURS
48	5.8	MAINTENANCE EVERY 1500 HOURS
48	5.9	PART REPLACEMENT AND ADJUSTMENT PROCEDURES
54	5.10	TROUBLESHOOTING

SECTION 6—NOISE CONTROL

57	6.1	NOISE EMISSIONS WARRANTY
57	6.2	TAMPERING WITH THE NOISE CONTROL SYSTEM IS PROHIBITED
58	6.3	NOISE EMISSIONS MAINTENANCE AND MAINTENANCE RECORD LOG

Section 1

SAFETY

NOTE



**OPERATOR IS REQUIRED TO READ
ENTIRE INSTRUCTION MANUAL.**

1.1 GENERAL

Sullair Corporation designs and manufactures all of its products so they can be operated safely. However, the responsibility for safe operation rests with those who use and maintain these products. The following safety precautions are offered as a guide which, if conscientiously followed, will minimize the possibility of accidents throughout the useful life of this equipment. **Read the CIMA Safety Manual prior to compressor operation and towing, if applicable in your area.**

The air compressor should be operated only by those who have been trained and delegated to do so, and who have read and understood this Operator's Manual. Failure to follow the instructions, procedures and safety precautions in this manual can result in accidents and injuries.

NEVER start the air compressor unless it is safe to do so. **DO NOT** attempt to operate the air compressor with a known unsafe condition. Tag the air compressor and render it inoperative by disconnecting the battery so others who may not know of the unsafe condition will not attempt to operate it until the condition is corrected.

Use and operate the air compressor only in full compliance with all pertinent OSHA requirements and/or all pertinent Federal, State and Local codes or requirements.

DO NOT modify the compressor except with written factory approval.

Each day, walk around the air compressor and inspect for leaks, loose or missing parts, damaged parts or parts out of adjustment. Perform all recommended daily maintenance.

Inspect for torn, frayed, blistered or otherwise deteriorated and degraded hoses. Replace as required.

! CAUTION

Estimated hose life based on a 5-day 8-hour work week is 3 years. These conditions exist on an 8-hour shift only. Any other operation of the equipment other than 8-hour shifts would shorten the hose life based on hours of operation.

1.2 TOWING (I)

PREPARING TO TOW

! WARNING

Do NOT tow the compressor should its weight exceed the rated limit of the tow vehicle, as the vehicle may not brake safely with excess weight. See rated limit in tow vehicle Operator's Manual, and review its instructions and other requirements for safe towing.

(I) WHILE NOT TOWED IN THE USUAL SENSE OF THE WORD, MANY OF THESE INSTRUCTIONS ARE DIRECTLY APPLICABLE TO SKID-MOUNTED PORTABLE AIR COMPRESSORS AS WELL.

- A. Prior to hitching the air compressor to the tow vehicle, inspect all attachment parts and equipment, checking for (i) signs of excessive wear or corrosion, (ii) parts that are cracked, bent, dented or otherwise deformed or degraded, and (iii) loose nuts, bolts or other fasteners. Should any such condition be present, **DO NOT TOW** until the problem is corrected.
- B. Back the tow vehicle to the compressor and position it in preparation for coupling the compressor.
- C. If the compressor is provided with a drawbar latched in the vertical upright position, carefully unlatch drawbar and lower it to engage the coupling device. If not, raise drawbar to engage coupling device or otherwise couple the compressor to the towing vehicle.

WARNING

This equipment may be tongue heavy. DO NOT attempt to raise or lower the drawbar by hand if the weight is more than you can safely handle.

Use the screw jack provided or a chain fall if you cannot lift or lower it without avoiding injury to yourself or others. Keep hands and fingers clear of the coupling device and all other pinch points. Keep feet clear of drawbar to avoid injury in case it should slip from your hands.

- D. Make sure the coupling device is fully engaged, closed and locked.
- E. If chains are provided, pass each chain through its point of attachment on the towing vehicle; then hook each chain to itself by passing the grab hook over (not through) a link. Cross chains under front of drawbar before passing them through points of attachment on towing vehicle to support front of drawbar in case it should accidentally become uncoupled.
- F. Make sure that the coupling device and adjacent structures on the towing vehicle (and also, if utilized, chain adjustment, brake and/or electrical interconnections) **DO NOT** interfere with or restrict motion of any part of the compressor, including its coupling device, with respect to the towing vehicle when maneuvering over any anticipated terrain.

- G. If provided, make sure chain length, brake and electrical interconnections provide sufficient slack to prevent strain when cornering and maneuvering, yet are supported so they cannot drag or rub on road, terrain or towing vehicle surfaces which might cause wear that could render them inoperative.

WARNING

This equipment may be tongue heavy. DO NOT attempt to raise or lower the drawbar by hand if the weight is more than you can safely handle.

CAUTION

Retract the front screw jack only after attaching the compressor to the tow vehicle. Raise the screw jack to its full up position and pull the pin connecting the jack to the drawbar. Rotate the screw jack to its stowed position, parallel to the drawbar, and reinsert the pin. Make sure the jack is secured in place prior to towing.

If a caster wheel is provided on the screw jack it is part of the screw jack and can not be removed. Follow the same procedure for stowing away the wheeled jack as you would for the standard screw jack. Pull the pin connecting the jack to the drawbar and raise the screw jack to its full up position. Rotate the screw jack to its stowed position, parallel to the drawbar, and reinsert the pin. Make sure the jack is secured in place prior to towing.

- H. On two-wheeled models, fully retract front screw jack and any rear stabilizer legs. If a caster wheel is provided on the screw jack it is part of the screw jack, and can not be removed. Follow the same procedure for stowing away the wheeled jack as you would for the standard screw jack. Pull the pin connecting the jack to the drawbar and raise the screw jack to its full upright position. Rotate the screw jack to its stowed position, parallel to the drawbar, and reinsert the pin. Make sure the jack is secured in place prior to towing.

SECTION 1

- I. Make sure tires are in good condition and are the size (load range) specified and are inflated to the specified pressures. **DO NOT** change the tire size or type. Also, make sure wheel bolts, lugs or nuts are tightened to the specified torques.
 - J. If provided, make sure all dual stop, tail directional and clearance lights are operating properly and that their lenses are clean and functional. Also, make sure all reflectors and reflecting surfaces, including the slow moving vehicle emblem on compressors provided with same, are clean and functional.
 - K. Make sure all service air hoses (not air brake hoses) are disconnected or are fully stowed and secured on hose reels, if provided.
 - L. Make sure all access doors and tool box covers are closed and latched. If the compressor is large enough to hold a man, make sure all personnel are out before closing and latching access doors.
 - M. Make sure parking brakes in towing vehicle are set, or that its wheels are chocked or blocked, or that it is otherwise restrained from moving. Then, release the compressor parking brakes, if provided.
 - N. Make sure the compressor wheels are not chocked or blocked, and that all tie-downs, if any, are free.
 - O. Test running brake operation, including break-away switch operation if provided, before attempting to tow the compressor at its rated speed or less when conditions prevail.
 - P. **DO NOT** carry loose or inappropriate tools, equipment or supplies on or in the compressor.
 - Q. **DO NOT** load this equipment with accessories or tools such that it is unbalanced from side to side or front to back. Such unbalance will reduce the towability of this equipment and may increase the possibility of tipping, rolling over, jackknifing, etc. Loss of control of the towing vehicle may result.
- according to posted speed limits, weather, traffic, road or terrain conditions:
1. Two axle four-wheel or three axle six-wheel steerable models: 15 MPH (24 km/h).
 2. All other models: 55 MPH (88 km/h).
- C. Remember that the portable air compressor may approach or exceed the weight of the towing vehicle. Maintain increased stopping distances accordingly. **DO NOT** make sudden lane changes, U-turns or other maneuvers. Such maneuvers can cause the compressor to tip, roll over, jackknife or slide and cause loss of control of the towing vehicle. Tipping, rolling over, etc. can occur suddenly without warning. U-turns especially should be made slowly and carefully.
 - D. Avoid grades in excess of 15° (27%).
 - E. Avoid potholes, rocks and other obstructions, and soft shoulders or unstable terrain.
 - F. Maneuver in a manner that will not exceed the freedom of motion of the compressor's drawbar and/ or coupling device, in or on the towing vehicle's coupling device and/or adjacent structure whether towing forward or backing up, regardless of the terrain being traversed.
 - G. **DO NOT** permit personnel to ride in or on the compressor.
 - H. Make sure the area behind, in front of, and under the compressor is clear of all personnel and obstructions prior to towing in any direction.
 - I. **DO NOT** permit personnel to stand or ride on the drawbar, or to stand or walk between the compressor and the towing vehicle.

PARKING OR LOCATING COMPRESSOR

- A. Park or locate compressor on a level surface, if possible. If not, park or locate compressor across grade so the compressor does not tend to roll downhill. **DO NOT** park or locate compressor on grades exceeding 15° (27%).
- B. Make sure compressor is parked or located on a firm surface that can support its weight.
- C. Park or locate compressor so the wind, if any, tends to carry the exhaust fumes and radiator heat away from the compressor air inlet openings, and also where the compressor will not be exposed to excessive dust from the work site.
- D. On steerable models, park compressor with front wheels in straight-ahead position.

- E. Set parking brakes and disconnect breakaway switch cable and all other interconnecting electrical and/or brake connections, if provided.
- F. Block or chock both sides of all wheels.
- G. If provided, unhook chains and remove them from the points of chain attachment on the towing vehicle, then hook chains to bail on drawbar or wrap chains around the drawbar and hook them to themselves to keep chains off the ground which might accelerate rusting.
- H. Lower front screw jack and/or any front and rear stabilizer legs. Make sure the surface they contact has sufficient load bearing capability to support the weight of the compressor.

WARNING

This equipment may be tongue heavy. **DO NOT** attempt to raise or lower the drawbar by hand if the weight is more than you can safely handle.

CAUTION

Retract the front screw jack only after attaching the compressor to the tow vehicle. Raise the screw jack to its full up position and pull the pin connecting the jack to the drawbar. Rotate the screw jack to its stowed position, parallel to the drawbar, and reinsert the pin. Make sure the jack is secured in place prior to towing.

On two-wheeled models, fully retract front screw jack and any rear stabilizer legs. If a caster wheel is provided on the screw jack it is part of the screw jack and can not be removed. Follow the same procedure for stowing away the wheeled jack as you would for the standard screw jack. Pull the pin connecting the jack to the drawbar and raise the screw jack to its full up position. Rotate the screw jack to its stowed position, parallel to the drawbar, and reinsert the pin. Make sure the jack is secured in place prior to towing.

- I. If a caster wheel is provided on the screw jack, it is part of the screw jack and cannot be removed. Follow the same procedure for stowing away the

wheeled jack as you would for the standard screw jack. Raise the screw jack to its full upright position and pull the pin connecting the jack to the drawbar. Rotate the screw jack to its stowed position, parallel to the drawbar and reinsert the pin. Make sure the jack is secured in place prior to towing.

- J. Disconnect coupling device, keeping hands and fingers clear of all pinch points. If the compressor is provided with a drawbar, **DO NOT** attempt to lift the drawbar or if hinged, to raise it to the upright position by hand, if the weight is more than you can safely handle. Use a screwjack or chain fall if you cannot lift or raise the drawbar without avoiding injury to yourself or others.
- K. When possible, stow hinged drawbar in the vertical upright position. Make certain it is securely latched in the vertical upright position. Keep feet clear of drawbar at all times to avoid crushing accidents in case it should slip from your hands or otherwise fall to the ground.
- L. Move the towing vehicle well clear of the parked compressor and erect hazard indicators, barricades and/or flares (if at night) if compressor is parked on or adjacent to public roads. Park so as not to interfere with traffic.

NOTE

While not towed in the usual sense of the word, many of these instructions are directly applicable to skidmounted portable air compressors as well.

1.3 PRESSURE RELEASE

- A. Open the pressure relief valve at least weekly to make sure it is not blocked, closed, obstructed or otherwise disabled.
- B. Install an appropriate flow-limiting valve between the compressor service air outlet and the shutoff (throttle) valve, when an air hose exceeding 1/2" (13 mm) inside diameter is to be connected to the shutoff (throttle) valve, to reduce pressure in case of hose failure, per OSHA Standard 29 CFR 1926.302 (b) (7) or any applicable Federal, State and Local codes, standards and regulations.
- C. When the hose is to be used to supply a manifold, install an additional appropriate flow-limiting valve between the manifold and each air hose

SECTION 1

be connected to the manifold to reduce pressure in case of hose failure.

- D. Provide an appropriate flow-limiting valve for each additional 75 feet (23 m) of hose in runs of air hose exceeding 1/2" (13 mm) inside diameter to reduce pressure in case of hose failure.
- E. Flow-limiting valves are listed by pipe size and rated CFM. Select appropriate valve accordingly.
- F. **DO NOT** use tools that are rated below the maximum rating of this compressor. Select tools, air hoses, pipes, valves, filters and other fittings accordingly. **DO NOT** exceed manufacturer's rated safe operating pressures for these items.
- G. Secure all hose connections by wire, chain or other suitable retaining device to prevent tools or hose ends from being accidentally disconnected and expelled.
- H. Open fluid filler cap only when compressor is not running and is not pressurized. Shut down the compressor and bleed the sump (receiver) to zero internal pressure before removing the cap.
- I. Vent all internal pressure prior to opening any line, fitting, hose, valve, drain plug, connection or other component, such as filters and line oilers, and before attempting to refill optional air line anti-icer systems with antifreeze compound.
- J. Keep personnel out of line with and away from the discharge opening of hoses, tools or other points of compressed air discharge.
- K. **DO NOT** use air at pressures higher than 30 psig (2.1 bar) for cleaning purposes, and then only with effective chip guarding and personal protective equipment per OSHA Standard 29 CFR 1910.242 (b) or any applicable Federal, State and Local codes, standards and regulations.
- L. **DO NOT** engage in horseplay with air hoses as death or serious injury may result.
- M. This equipment is supplied with an ASME designed pressure vessel protected by an ASME rated relief valve. Lift the handle once a week to make sure the valve is functional. **DO NOT** lift the handle while machine is under pressure.
- N. If the machine is installed in an enclosed area it is necessary to vent the relief valve to the outside of the structure or to an area of non-exposure.
- O. **DO NOT** remove radiator filler cap until the coolant temperature is below its boiling point. Then loosen cap slowly to its stop to relieve any

excess pressure and make sure coolant is not boiling before removing cap completely. Remove radiator filler cap only when cool enough to touch with a bare hand.

- P. The ethyl ether in the replaceable cylinders used in diesel ether starting aid systems (optional) is under pressure. **DO NOT** puncture or incinerate those cylinders. **DO NOT** attempt to remove the center valve core or side pressure relief valve from these cylinders regardless of whether they are full or empty.
- Q. If a manual blowdown valve is provided on the receiver, open the valve to ensure all internal pressure has been vented prior to servicing any pressurized component of the compressor air/fluid system.

1.4 FIRE AND EXPLOSION



WARNING

Do not attempt to operate the compressor in any classification of hazardous environment or potentially explosive atmosphere unless the compressor has been specially designed and manufactured for that duty.

- A. Refuel at a service station or from a fuel tank designed for its intended purpose. If this is not possible, ground the compressor to the dispenser prior to refueling.
- B. Clean up spills of fuel, fluid, battery electrolyte or coolant immediately if such spills occur.
- C. Shut off air compressor and allow it to cool. Then keep sparks, flames and other sources of ignition away and **DO NOT** permit smoking in the vicinity when adding fuel, or when checking or adding electrolyte to batteries, or when checking or adding fluid, or when checking diesel engine ether starting aid systems or replacing cylinders, or when refilling air line anti-icer systems antifreeze compound.
- D. **DO NOT** permit liquids, including air line anti-icer system antifreeze compound or fluid film, to accumulate on bottom covers or on, under or around acoustical material, or on any external or internal surfaces of the air compressor. Wipe down using an aqueous industrial cleaner or steam clean as required. If necessary, remove

acoustical material, clean all surfaces and then replace acoustical material. Any acoustical material with a protective covering that has been torn or punctured should be replaced immediately to prevent accumulation of liquids or fluid film within the material. **DO NOT** use flammable solvents for cleaning purposes.

- E. Disconnect the grounded (negative) battery connection prior to attempting any repairs or cleaning inside the enclosure. Tag the battery connections so others will not unexpectedly reconnect it.
- F. Keep electrical wiring, including the battery terminals and other terminals, in good condition. Replace any wiring that has cracked, cut abraded or otherwise degraded insulation or terminals that are worn, discolored or corroded. Keep all terminals clean and tight.
- G. Turn off battery charger before making or breaking connections to the battery.
- H. Keep grounded conductive objects such as tools away from exposed live electrical parts such as terminals to avoid arcing which might serve as a source of ignition.
- I. Replace damaged fuel tanks or lines immediately rather than attempt to weld or otherwise repair them. **DO NOT** store or attempt to operate the compressor with any known leaks in the fuel system. Tag the compressor and render it inoperative until repair can be made.
- J. Remove any acoustical material or other material that may be damaged by heat or that may support combustion prior to attempting weld repairs. Remove diesel engine ether starting aid cylinders and air line anti-icer system components containing antifreeze compound, prior to attempting weld repairs in any place other than the fuel system. **DO NOT** weld on or near the fuel system.
- K. Keep a suitable, fully charged class BC or ABC fire extinguisher or extinguishers nearby when servicing and operating the compressor.
- L. Keep oily rags, trash, leaves, litter or other combustibles out of and away from the compressor.
- M. Open all access doors and allow the enclosure to ventilate thoroughly prior to attempting to start the engine.
- N. **DO NOT** operate compressor under low overhanging leaves or permit such leaves to contact hot exhaust system surfaces when operating the compressor in forested areas.
- O. Ethyl ether used in diesel engine ether starting aid systems is extremely flammable. Change cylinders, or maintain or troubleshoot these systems only in well-ventilated areas away from heat, open flame or sparks. **DO NOT** install, store or otherwise expose ether cylinders to temperatures above 160 °F (71 °C). Remove ether cylinder from the compressor when operating in ambient temperatures above 60 °F (16 °C).
- P. **DO NOT** attempt to use ether as a starting aid in gasoline engines or diesel engines with glow plugs as serious personnel injury or property damage may result.
- Q. **DO NOT** spray ether into compressor air filter or into an air filter that serves both the engine and the compressor as serious damage to the compressor or personal injury may result.
- R. Antifreeze compound used in air line anti-icer systems contains methanol which is flammable. Use systems and refill with compound only in well-ventilated areas away from heat, open flames or sparks. **DO NOT** expose any part of these systems or the antifreeze compound to temperatures above 150 °F (66 °C). Vapors from the antifreeze compound are heavier than air. **DO NOT** store compound or discharge treated air in confined or unventilated areas. **DO NOT** store containers of antifreeze compound in direct sunlight.
- S. Store flammable fluids and materials away from your work area. Know where fire extinguishers are and how to use them, and for what type of fire they are intended. Check readiness of fire suppression systems and detectors if so equipped.

1.5 MOVING PARTS

- A. Keep hands, arms and other parts of the body and also clothing away from belts, pulleys and other moving parts.
- B. **DO NOT** attempt to operate the compressor with the fan or other guards removed.
- C. Wear snug-fitting clothing and confine long hair when working around this compressor, especially when exposed to hot or moving parts inside the enclosure.

SECTION 1

- D. Keep access doors closed except when making repairs or adjustments, performing service or when starting or stopping the compressor.
- E. Make sure all personnel are out of and clear of the compressor prior to attempting to start or operate it.
- F. Shut off engine before adding fuel, fluid, coolant lubricants, air line antifreeze compound or battery electrolyte, or before replacing ether starting aid cylinders.
- G. Disconnect the grounded negative battery connection to prevent accidental engine operation prior to attempting repairs or adjustments. Tag the battery connection so others will not unexpectedly reconnect it.
- H. When adjusting the controls, it may require operation of the equipment during adjustment. **DO NOT** come in contact with any moving parts while adjusting the control regulator and setting the engine RPM. Make all other adjustments with the engine shut off. When necessary, make adjustment, other than setting control regulator and engine RPM, with the engine shut off. If necessary, start the engine and check adjustment. If adjustment is incorrect, shut engine off, readjust, then restart the engine to recheck adjustment.
- I. Keep hands, feet, floors, controls and walking surfaces clean and free of fluid, water, antifreeze or other liquids to minimize possibility of slips and falls.

1.6 HOT SURFACES, SHARP EDGES AND SHARP CORNERS

- A. Avoid bodily contact with hot fluid, hot coolant, hot surfaces and sharp edges and corners.
- B. Keep all parts of the body away from all points of air discharge and away from hot exhaust gases.
- C. Wear personal protective equipment including gloves and head covering when working in, on or around the compressor.
- D. Keep a first aid kit handy. Seek medical assistance promptly in case of injury. **DO NOT** ignore small cuts and burns as they may lead to infection.

1.7 TOXIC AND IRRITATING SUBSTANCES

- A. **DO NOT** use air from this compressor for respiration (breathing) except in full compliance with OSHA Standards 29 CFR 1920 and any other Federal, State or Local codes or regulations.

 **DANGER**



INHALATION HAZARD!
Death or serious injury can result from inhaling compressed air without using proper safety equipment. See OSHA standards and/or any applicable Federal, State, and Local codes, standards and regulations on safety equipment.

- B. **DO NOT** use air line anti-icer systems in air lines supplying respirators or other breathing air utilization equipment and **DO NOT** discharge air from these systems into unventilated or other confined areas.
- C. Operate the compressor only in open or well-ventilated areas.
- D. If the compressor is operated indoors, discharge engine exhaust fumes outdoors.
- E. Locate the compressor so that exhaust fumes are not apt to be carried towards personnel, air intakes servicing personnel areas or towards the air intake of any portable or stationary compressor.
- F. Fuels, fluids, coolants, lubricants and battery electrolyte used in the compressor are typical of the industry. Care should be taken to avoid accidental ingestions and/or skin contact. In the event of ingestion, seek medical treatment promptly. **DO NOT** induce vomiting if fuel is ingested. Wash with soap and water in the event of skin contact.
- G. Wear an acid-resistant apron and a face shield or goggles when servicing the battery. If electrolyte

is spilled on skin or clothing, immediately flush with large quantities of water.

- H. Ethyl ether used in diesel engine ether starting aid systems is toxic, harmful or fatal if swallowed. Avoid contact with the skin or eyes and avoid breathing the fumes. If swallowed, **DO NOT** induce vomiting, but call a physician immediately.
- I. Wear goggles or a full face shield when testing ether starting aid systems or when adding anti-freeze compound to air line anti-icer systems. Keep openings of valve or atomizer tube of ether starting aid system pointed away from yourself and other personnel.
- J. If ethyl ether or air line anti-icer system anti-freeze compound enters the eyes or if fumes irritate the eyes, they should be washed with large quantities of clean water for 15 minutes. A physician, preferably any eye specialist, should be contacted immediately.
- K. **DO NOT** store ether cylinders or air line anti-icer system antifreeze compound in operator's cabs or in other similar confined areas.
- L. The antifreeze compound used in air line anti-icer systems contains methanol and is toxic, harmful or fatal if swallowed. Avoid contact with the skin or eyes and avoid breathing the fumes. If swallowed, induce vomiting by administering a tablespoon of salt in each glass of clean warm water until vomit is clear, then administer two tablespoons of baking soda in a glass of clean water. Have patient lay down and cover eyes to exclude light. Call a physician immediately.

1.8 ELECTRICAL SHOCK

- A. Keep the towing vehicle or equipment carrier, compressor hoses, tools and all personnel at least 10 feet (3 m) from power lines and buried cables.
- B. Keep all parts of the body and any hand-held tools or other conductive objects away from exposed live parts of electrical system. Maintain dry footing, stand on insulating surfaces and **DO NOT** contact any other portion of the compressor when making adjustments or repairs to exposed live parts of the electrical system.
- C. Attempt repairs only in clean, dry and well-lighted and ventilated areas.
- D. Stay clear of the compressor during electrical storms! It can attract lightning.

1.9 LIFTING

- A. If the compressor is provided with a lifting bail, then lift by the bail provided. If no bail is provided, then lift by sling. Compressors to be air lifted by helicopter must not be supported by the lifting bail, but by slings instead. In any event, lift only in full compliance with OSHA Standards 29 CFR 1910 subpart N or any other Local, State, Military and Federal regulations that may apply.
- B. Inspect lifting bail and points of attachment for cracked welds and for cracked, bent, corroded or otherwise degraded members and for loose bolts or nuts prior to lifting.
- C. Make sure entire lifting, rigging and supporting structure has been inspected, is in good condition and has a rated capacity of at least the net weight of the compressor plus an additional 10% allowance for weight of snow, ice, mud or stored tools and equipment. If you are unsure of the weight, then weigh compressor before lifting.
- D. Make sure lifting hook has a functional safety latch or equivalent, and is fully engaged and latched on the bail.
- E. Use guide ropes or equivalent to prevent twisting or swinging of the compressor once it has been lifted clear of the ground.
- F. **DO NOT** attempt to lift in high winds.
- G. Keep all personnel out from under and away from the compressor whenever it is suspended.
- H. Lift compressor no higher than necessary.
- I. Keep lift operator in constant attendance whenever compressor is suspended.
- J. Set compressor down only on a level surface capable of supporting at least its net weight plus an additional 10% allowance for the weight of snow, ice, mud or stored tools and equipment.
- K. If the compressor is provided with parking brakes, make sure they are set, and in any event, block or chock both sides of all running wheels before disengaging the lifting hook.

1.10 ENTRAPMENT

- A. Make sure all personnel are out of compressor before closing and latching enclosure doors.
- B. If the compressor is large enough to hold a man and if it is necessary to enter it to perform service

SECTION 1

else secure the access door in the open position to avoid the possibility of others closing and possibly latching the door with personnel inside.

1.11 JUMP STARTING

- A. Observe all safety precautions mentioned elsewhere in this manual.
- B. Batteries may contain hydrogen gas which is flammable and explosive. Keep flames, sparks and other sources of ignition away.
- C. Batteries contain acid which is corrosive and poisonous. **DO NOT** allow battery acid to contact eyes, skin, fabrics or painted surfaces as serious personal injury or property damage could result. Flush any contacted areas thoroughly with water immediately. Always wear an acid-resistant apron and face shield when attempting to jump start the compressor.
- D. Remove all vent caps (if so equipped) from the battery or batteries in the compressor. **DO NOT** permit dirt or foreign matter to enter the open cells.
- E. Check fluid level. If low, bring fluid to proper level before attempting to jump start (not applicable to maintenance-free batteries).
- F. **DO NOT** attempt to jump start if fluid is frozen or slushy. Bring batteries up to at least 60 °F (16 °C) before attempting to jump start or it may explode.
- G. Cover open cells of all compressor batteries with clean dampened cloths before attempting to jump start.
- H. Attempt to jump start only with a vehicle having a negative ground electrical system with the same voltage, and is also equipped with a battery or batteries of comparable size or larger than supplied in the compressor. **DO NOT** attempt to jump start using motor generator sets, welders or other sources of DC power as serious damage may result.
- I. Bring the starting vehicle alongside the compressor, but **DO NOT** permit metal to metal contact between the compressor and the starting vehicle.
- J. Set the parking brakes of both the compressor (if provided) and the starting vehicle or otherwise block both sides of all wheels.
- K. Place the starting vehicle in neutral or park, turn off all non-essential accessory electrical loads and start its engine.
- L. Use only jumper cables that are clean, in good condition and are heavy enough to handle the starting current.
- M. Avoid accidental contact between jumper cable terminal clips or clamps and any metallic portion of either the compressor or the starting vehicle to minimize the possibility of uncontrolled arcing which might serve as a source of ignition.
- N. Positive battery terminals are usually identified by a plus (+) sign on the terminal and the letters POS adjacent to the terminal. Negative battery terminals are usually identified by the letters NEG adjacent to the terminal or a negative (-) sign.
- O. Connect one end of a jumper cable to the positive (POS) (+) battery terminal in the starting vehicle. When jump starting 24V compressors and if the starting vehicle is provided with two (2) 12V batteries connected in series, connect the jumper cable to the positive (POS) (+) terminal of the ungrounded battery.
- P. Connect the other end of the same jumper cable to the positive (POS) (+) terminal of the starter motor battery in the compressor, or when jump starting 24V compressor, to the positive (POS) (+) terminal of the ungrounded battery in the compressor.
- Q. Connect one end of the other jumper cable to the grounded negative (NEG) (-) terminal of the battery in the starting vehicle. When jump starting 24V compressors and if the starting vehicle is provided with two (2) 12V batteries connected in series, connect the jumper cable to the negative (NEG) (-) terminal of the grounded battery.
- R. Check your connections. **DO NOT** attempt to start a 24V compressor with one 12V battery in the starting vehicle. **DO NOT** apply 24V to one 12V battery in the compressor.
- S. Connect the other end of this same jumper cable to a clean portion of the compressor engine block away from fuel lines, the crank case breather opening and the battery.
- T. Start the compressor in accordance with normal procedure. Avoid prolonged cranking.
- U. Allow the compressor to warm up. When the compressor is warm and operating smoothly at

normal idle RPM, disconnect the jumper cable from the engine block in the compressor, then disconnect the other end of this same cable from the grounded negative (NEG) (-) terminal of the battery in the starting vehicle. Then disconnect the other jumper cable from the positive (POS) (+) terminal of the battery in the compressor, or if provided with two (2) 12V batteries connected in series, from the ungrounded battery in the compressor, and finally, disconnect the other end of this same jumper cable from the positive (POS) (+) terminal of the battery in the starting vehicle or from the positive (POS) (+) terminal of the ungrounded battery in the starting vehicle, if it is provided with two (2) 12V batteries connected in series.

- V. Remove and carefully dispose of the dampened cloths, as they may now be contaminated with acid, then replace all vent caps.

1.12 IMPLEMENTATION OF LOCKOUT/TAGOUT

The energy control procedure defines actions necessary to lockout a power source of any machine to be repaired, serviced or set-up, where unexpected motion, or an electrical or other energy source, would cause personal injury or equipment damage. The power source on any machine shall be locked out by each employee doing the work except when motion is necessary during setup, adjustment or troubleshooting.

- A. The established procedures for the application of energy control shall cover the following elements and actions and shall be initiated only by Authorized Persons and done in the following sequence:

1. Review the equipment or machine to be locked and tagged out.
2. Alert operator and supervisor of which machine is to be worked on, and that power and utilities will be turned off.
3. Check to make certain no one is operating the machine before turning off the power.
4. Turn off the equipment using normal shutdown procedure.
5. Disconnect the energy sources:
 - a. Air and hydraulic lines should be bled, drained and cleaned out. There should be no pressure in these lines or in the

reservoir tanks. Lockout or tag lines or valves.

- b. Any mechanism under tension or pressure, such as springs, should be released and locked out or tagged.
 - c. Block any load or machine part prior to working under it.
 - d. Electrical circuits should be checked with calibrated electrical testing equipment and stored energy and electrical capacitors should be safely discharged.
6. Lockout and/or Tagout each energy source using the proper energy isolating devices and tags. Place lockout hasp and padlock or tag at the point of power disconnect where lockout is required by each person performing work. Each person shall be provided with their own padlock and have possession of the only key. If more than one person is working on a machine each person shall affix personal lock and tag using a multi-lock device.
7. Tagout devices shall be used only when power sources are not capable of being locked out by use of padlocks and lockout hasp devices. Name of person affixing tag to power source must be on tag along with date tag was placed on power source.
8. Release stored energy and bring the equipment to a "zero mechanical state".
9. Verify Isolation: Before work is started, test equipment to ensure power is disconnected.

B. General Security

1. The lock shall be removed by the "Authorized" person who put the lock on the energy-isolating device. No one other than the person/persons placing padlock and lockout hasp on power shall remove padlock and lockout hasps and restore power. However, when the authorized person who applied the lock is unavailable to remove it his/her Supervisor may remove padlock/padlocks and lockout hasps and restore power only if it is first:
 - a. verified that no person will be exposed to danger.
 - b. verified that the "Authorized" person who applied the device is not in the facility.
 - c. noted that all reasonable efforts to contact the "Authorized" person have been made to inform him or her that the lockout or tagout device has been removed.

SECTION 1

- d. ensured that the “Authorized” person is notified of lock removal before returning to work.
2. Tagout System—Tags are warning devices affixed at points of power disconnect and are not to be removed by anyone other than the person placing tag on power lockout. Tags shall never be by-passed, ignored, or otherwise defeated

1.13 CALIFORNIA PROPOSITION 65



WARNING

























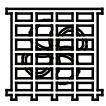





CALIFORNIA PROPOSITION 65 WARNING

Diesel engine exhaust and some of its constituents are known to the State of California to cause cancer, birth defects and other reproductive harm.

Battery posts, terminals and related accessories contain lead and other compounds known to the State of California to cause cancer and birth defects and other reproductive harm. Wash hands after handling.





















1.14 SYMBOLS AND REFERENCES





















The symbols below may or may not be used. Please refer to the decals set forth on the machine for applicable symbols.





	DIESEL FUEL		ENGINE
	FUEL LEVEL		ENGINE COOLANT
	INTERNAL FUEL		ENGINE COOLANT TEMPERATURE
	EXTERNAL FUEL		ENGINE ECM
	BATTERY		ENGINE INTAKE AIR FILTER
	BATTERY DISCONNECT		ENGINE OIL
	SHUT-OFF VALVE WITH SAFETY		ENGINE OIL PRESSURE
	OPERATE WITH FAN GUARDS IN PLACE		ENGINE PREHEAT/LOW TEMPERATURE AID
	OPERATE WITH BELT GUARDS IN PLACE		ENGINE RPM
	READ/WRITE DATA		ENGINE START
	INTAKE AIR		ENGINE WARNING
	EXHAUST GAS		ROTARY COMPRESSOR
	SERVICE POINT		COMPRESSOR
			COMPRESSOR AIR PRESSURE
			COMPRESSOR TEMPERATURE
			INLET VALVE SPRING OIL (AWF)
			ENGINE SHUTDOWN
			COMPRESSOR SHUTDOWN

Safety Symbols-1



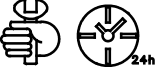
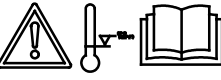









SECTION 1











	READ MANUAL
	HOUR METER
	START
	ON
	OFF
	RESET
	NO
	EXAMINE, CHECK
	FORK LIFT HERE
	NO FORK LIFT
	FUSE
	CLOSED, MECHANICAL
	WATER
	OIL
	FUNCTIONAL ARROW
	FILTER
	RADIATOR
	STRAINER
	AFTERCOOLED AIR
	STANDARD AIR

	DIRECTION OF ROTATION
	PRESSURE
	LIFT POINT
	TIE DOWN
	AIR COOLED OIL COOLER
	LIQUID COOLED OIL COOLER
	CONTROL
	BELOW TEMPERATURE
	AIR-CIRCULATING FAN
	TEST SWITCH
	BELTS
	24 HOURS
	PRESSURE CONTROL
	LOW PRESSURE
	HIGH PRESSURE
	LUBRICATION
	TRAILER TOWING MODE
	AXLE
	LUBRICANT GREASE
	DRAIN

	SERVICE EVERY 24 HOURS
	WARNING, FOR BELOW 0°C (32°F) READ MANUAL
	WATER CONDENSATE (DO NOT PLUG)
	COMPRESSOR OIL DRAIN
	ENGINE COOLANT DRAIN
	ENGINE OIL DRAIN

Safety Symbols-3

	DO NOT
	DO NOT BREATH COMPRESSOR AIR
	DO NOT REMOVE MANUAL
	DO NOT STAND ON SERVICE VALVE
	DO NOT OPERATE COMPRESSOR WITH DOORS OPEN
	DO NOT OPEN AIR VALVES WITHOUT CONNECTED HOSES
	DO NOT STACK
	DO NOT MAINTENANCE
	DO NOT TOW
	SIDE DOOR T-LATCH
	BRAKES
	DO NOT MIX COOLANTS
	AFTERCOOLER BYPASS VALVE

	WARNING
	WARNING, ELECTRICAL SHOCK
	WARNING, AIR FLOW
	WARNING, HOT SURFACE
	WARNING, PRESSURISED VESSEL
	WARNING, PRESSURISED COMPONENT
	WARNING, DANGEROUS OUTLET
	WARNING, REMOTELY CONTROLLED
	WARNING, LOW TEMPERATURE
	WARNING, CRUSH/PINCH POINT
	CORROSIVE

Section 2

DESCRIPTION

2.1 INTRODUCTION

The Sullair 225H and 260 CFM Standard Portable Air Compressors offer superior performance, reliability and require a minimal amount of maintenance. Compared to other compressors, Sullair's are unique in terms of reliability and durability. Compressor internal components require no routine maintenance inspections.

2.2 DESCRIPTION OF COMPONENTS

Figure 2-1 shows the main components and subassemblies of the Sullair 225H and 260 Standard Portable Air Compressors. These packages include a heavy duty rotary screw air compressor, a diesel engine, fuel tank, compressor inlet system, compressor cooling and lubrication system, compressor discharge system, capacity control system, instrument panel and electrical system. A low profile canopy offers improved handling and mobility. Large side service doors provide easy access to all servicable components. The models meet United States EPA Sound Level regulations of 76dBA at 7 meters (23 ft). Sullair air compressors have the following delivery capacities:

MODEL 225H: 225 cfm @ 150 psig (10.3 bar)

MODEL 260: 260 cfm @ 100 psig (6.9 bar)

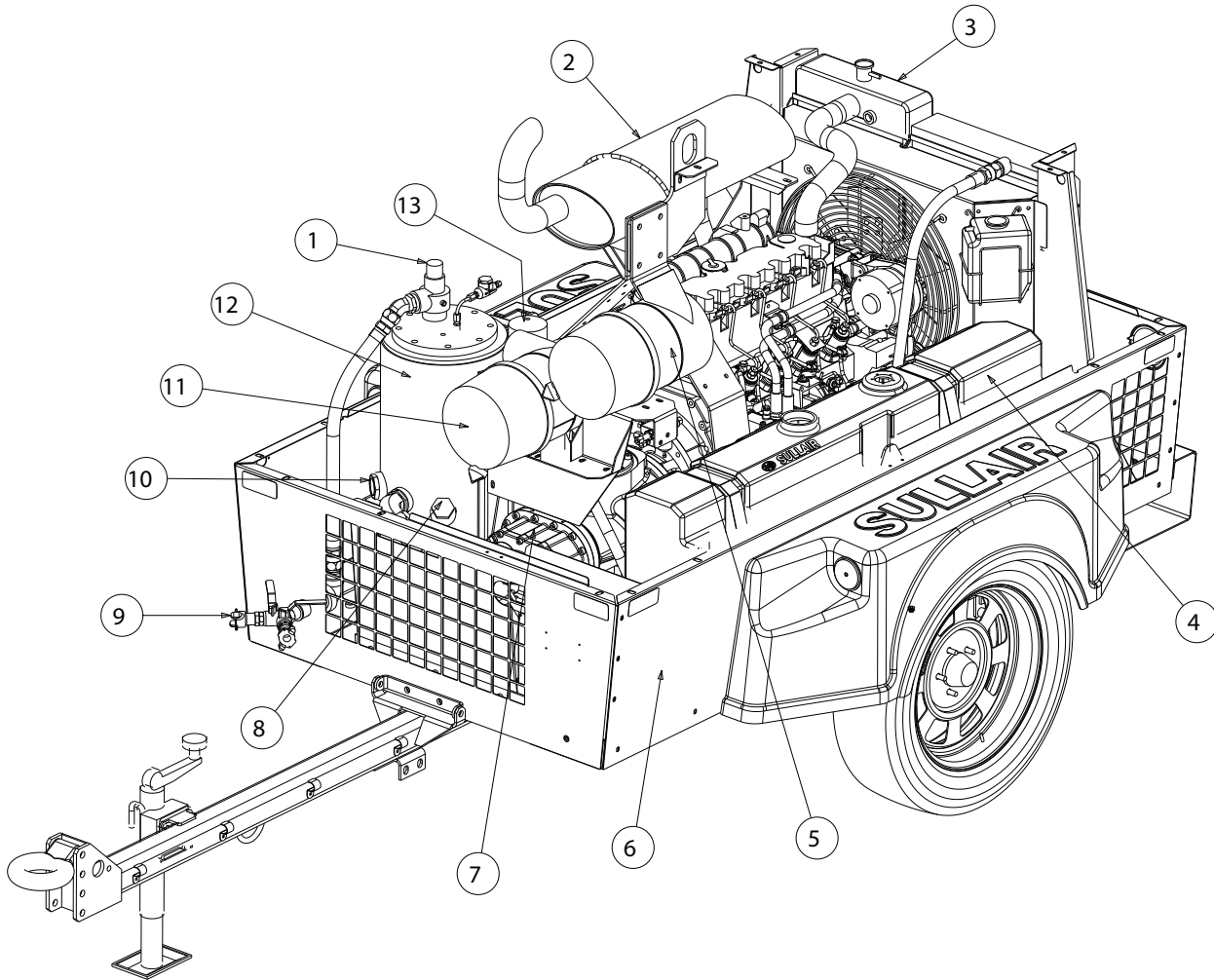

Figure 2-1: Sullair Rotary Screw Portable Air Compressor

- | | |
|-----------------------------------|---|
| 1. Minimum Pressure/Check Valve | 9. Service Valves |
| 2. Engine Muffler | 10. Fluid Level Sight Glass |
| 3. Radiator/Fluid Cooler Assembly | 11. Compressor Air Filter |
| 4. Fuel Tank | 12. Receiver Tank |
| 5. Engine Air Filter | 13. Thermal Valve/Compressor Fluid Filter |
| 6. Battery | |
| 7. Compressor Unit | |
| 8. Fluid Fill | |

The control system can easily be adjusted for pressures from 80 to 125 psig (5.6 to 8.6 bar) for standard machines and from 80 to 150 psig (5.6 to 10.3 bar) for “H” or high pressure machines. The compressor unit is driven by an industrial diesel engine designed to provide enough horsepower to provide an adequate reserve under rated conditions.

Refer to the **Engine Operator’s Manual** for a more detailed description of the engine. The engine cooling system is comprised of a radiator, high capacity fan, and thermostat. The high capacity fan pushes air through the radiator to maintain the engine’s specified operating temperature. The same fan also cools the fluid in the compressor cooling and lubrication system.

The engine radiator and the compressor fluid cooler are next to each other allowing the fan air to push through both simultaneously. As air passes through the fluid cooler, the heat of compression is removed from the fluid.

2.3 SULLAIR COMPRESSOR UNIT, FUNCTIONAL DESCRIPTION

Sullair compressors are single-stage, positive displacement, flood lubricated-type compressors that provide continuous (pulse-free) compression to meet various demand loads. Sullair compressors require no routine maintenance or inspection of their internal parts or systems. The compressor works by injecting fluid into the compressor unit where it mixes directly with the air as the rotors turn. The fluid flow has three main functions:

1. It acts as a coolant, to control the rise of air temperature which is generated by compression (heat of compression).
2. Seals the leakage paths between the rotors and the stator and also between the rotors themselves.
3. Lubricates the rotors allowing one rotor to directly drive the other.

After the air/fluid mixture is discharged from the compressor unit, the fluid is separated from the air. At this time, the air flows to the service line and the fluid is cooled in preparation for re-injection.

2.4 COMPRESSOR COOLING AND LUBRICATION SYSTEM, FUNCTIONAL DESCRIPTION

Refer to *Figure 2-2*. The compressor cooling and lubrication system is designed to provide adequate lubrication as well as maintain the proper operating temperature of the compressor. In addition to the fluid cooler and interconnecting piping, the system consists also of three other components: a fluid filter, thermal valve, and a fan which perform the following functions:

- The fluid filter removes and collects any contaminants in the fluid.
- The thermal valve functions as a temperature regulator directing fluid either to the cooler or to the compressor unit.
- The fan pushes air through the cooler dissipating the heat resulting from compression of the fluid.

The functions of the lubrication system are explained in more detail below. Fluid is used in the system as a coolant and as a lubricant: the air-oil receiver tank serves as the fluid reservoir. At start-up, fluid flows from the air-oil receiver tank to the fluid thermal valve. Fluid circulation is achieved by forcing the fluid from the high pressure region of the air-oil receiver tank to a lower pressure area in the compressor unit. A minimum pressure device (See *Compressor Discharge System, Functional Description* on page 20) is provided to assure adequate fluid flow under all conditions. When entering the thermal valve upon start-up, the fluid temperature is cool and thus it is not necessary to route it through the cooler. The fluid flows through the fluid filter and on to the compressor unit bypassing the cooler. As the compressor continues to operate, the temperature of the fluid rises and the thermostatic control opens, allowing a portion of the fluid into the cooler.

When the temperature reaches 170°F (77°C), the thermostat is fully open allowing all fluid entering the thermal valve to flow to the cooler.

The cooler is a radiator type that works in concert with the engine fan. The fan pushes air through the cooler removing the heat from the fluid. From the cooler, the fluid is then routed back through the fluid filter. All fluid flowing to the compressor unit passes through this filter. The fluid leaving the filter flows to the compressor unit where it lubricates, seals and cools the compression chamber; and lubricates the bearings and gears.

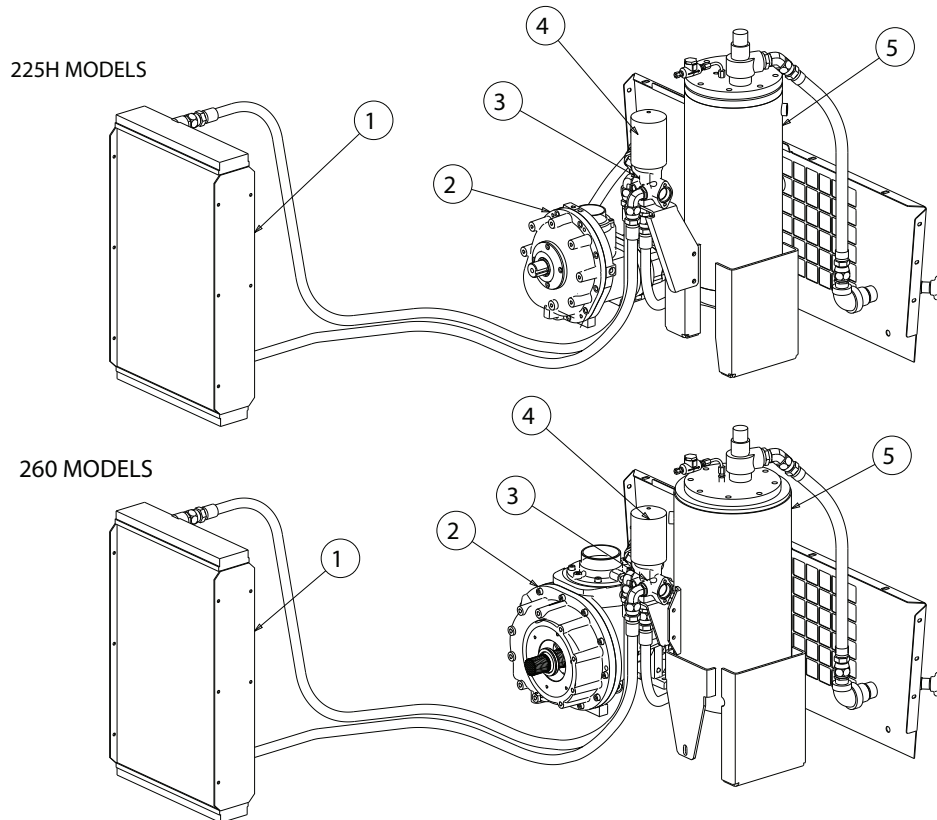

Figure 2-2: Compressor Cooling and Lubrication System

- | | |
|------------------|--------------------------|
| 1. Fluid Cooler | 4. Fluid Filter |
| 2. Compressor | 5. Air-Oil Receiver Tank |
| 3. Thermal Valve | |

2.5 COMPRESSOR DISCHARGE SYSTEM, FUNCTIONAL DESCRIPTION

Refer to *Figure 2-3*. The Sullair compressor unit discharges a compressed air/fluid mixture into the receiver tank. The receiver tank has three functions:

1. It acts as a primary fluid separator.
2. Serves as the compressor fluid reservoir.
3. Houses the air/fluid separator.

The compressed air/fluid mixture enters the receiver tank and is directed against the side of the air-oil receiver tank. Because of a change of direction and reduction of velocity, large droplets of fluid separate and fall to the bottom of the sump. The small amount of fluid remaining in the compressed air collects on the surface of the separator element as the compressed air flows through the separator. As more

fluid collects on the element surface, it then flows to the bottom of the separator. A return line (or scavenge tube) leads from the bottom of the separator element to the inlet region of the compressor unit. Fluid collecting on the bottom of the separator element is returned to the compressor by the pressure difference between the area surrounding the separator element and the compressor inlet. An orifice (protected by a strainer) is included in this return line to assure proper and unobstructed flow. The receiver tank is code rated at 200 psig (13.8 bar) working pressure. A minimum pressure device located downstream from the separator, ensures a minimum receiver pressure of 80 psig (5.5 bar) during all conditions. Keeping this pressure level stable is necessary for proper air/fluid separation and proper fluid circulation. A pressure relief valve (located on the wet side of the separator) is set to open if the air-oil receiver tank pressure exceeds 200 psig (13.8 bar).

Fluid is added to the receiver tank through a capped fluid fill port.

WARNING

DO NOT remove caps, plugs and/or other components when the compressor is running or pressurized. Stop the compressor and relieve all internal pressure before removing these items.

2.6 CAPACITY CONTROL SYSTEM, FUNCTIONAL DESCRIPTION

Refer to *Figure 2-4* or *Figure 2-5*. The purpose of the control system is to regulate the amount of air intake and match it to the demand (required output) on the compressor. The control system consists of a pressure regulating valve(s), air inlet valve, system blowdown valve, engine speed control, and tubing connecting the various components of the

compressor and engine. The functional descriptions of the control system are described by relating them to four distinct phases of operation. They apply to any control system with the exception of those with specified pressures which are dependent on pressure requirements. The given values apply to a compressor with an operating pressure range of 100 to 110 psig (6.9 to 7.6 bar).

START – 0 TO 40 PSIG (0 TO 2.8 BAR)

When the compressor is started, the air-oil receiver tank pressure quickly rises from 0 to 40 psig (0 to 2.8 bar). During this period the pressure regulator valve is inactive. At this pressure range the idle warm-up control keeps the inlet valve closed for engine idle operation. After 30 seconds of starting the compressor (the instrument panel annunciator light goes off after 30 seconds) turn the handle of the warm-up selector valve (located on the instrument panel) from the START to the RUN position. The inlet valve fully opens due to inlet pressure, and the compressor now operates at full capacity. When the compressor operates at full capacity, the engine runs at full speed.

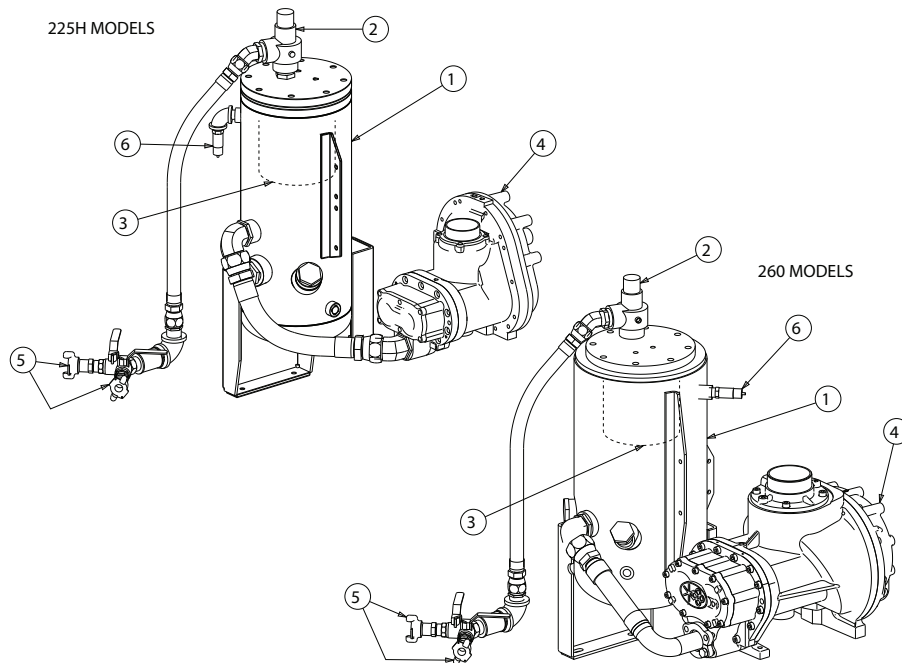

Figure 2-3: Compressor Discharge System

- | | |
|---------------------------------------|--------------------------|
| 1. Receiver/Tank | 4. Compressor Unit |
| 2. Minimum Pressure/Check Valve | 5. Service Valve Outlets |
| 3. Internal Air/Oil Separator Element | 6. Pressure Relief Valve |

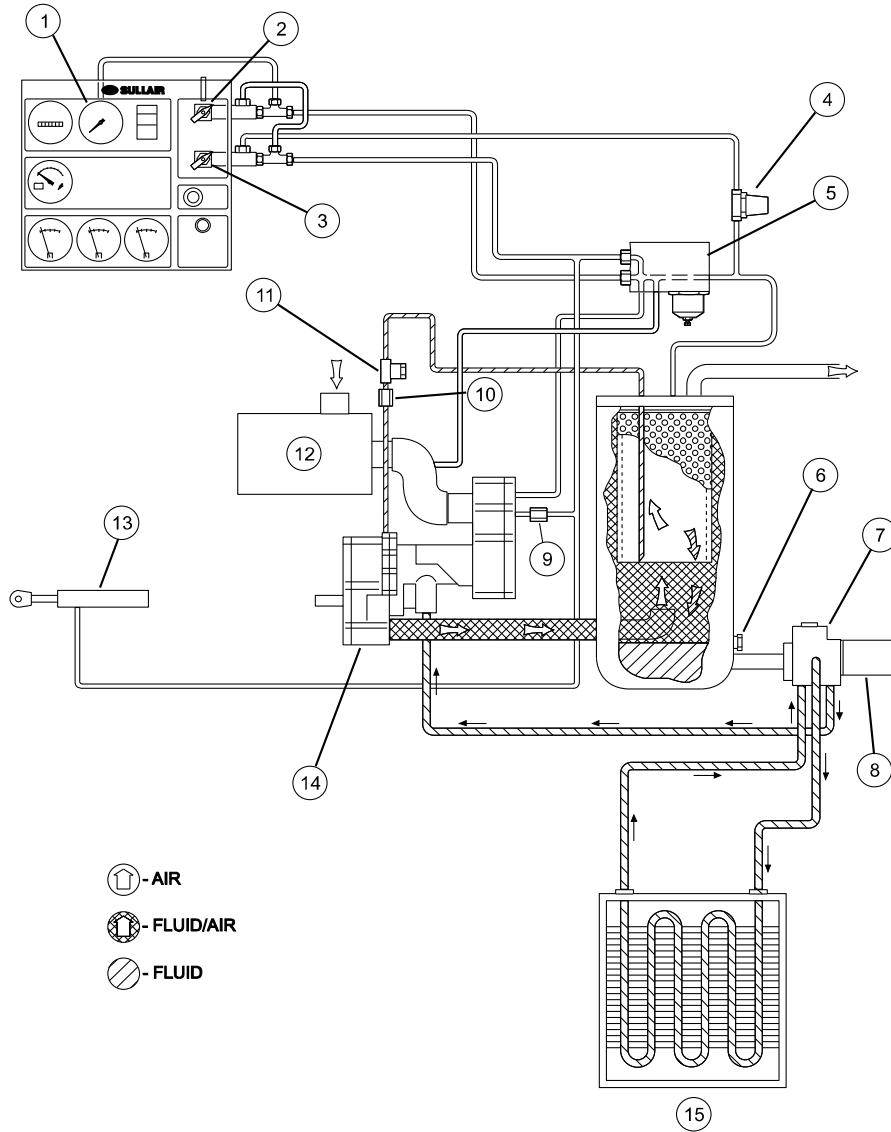

Figure 2-4: Control System with Piping and Instrumentation—225H Models

- | | |
|--|---------------------|
| 1. Air Pressure Gauge | 8. Fluid Filter |
| 2. Idle Warm-Up Control Selector Valve | 9. Check Valve |
| 3. High/Low Pressure Selector Switch | 10. Orifice |
| 4. Low Pressure Regulator Valve | 11. Strainer |
| 5. Regulator/Blowdown Valve | 12. Air Filter |
| 6. Fluid Level Sight Glass | 13. Engine |
| 7. Thermal Valve | 14. Compressor Unit |
| | 15. Fluid Cooler |

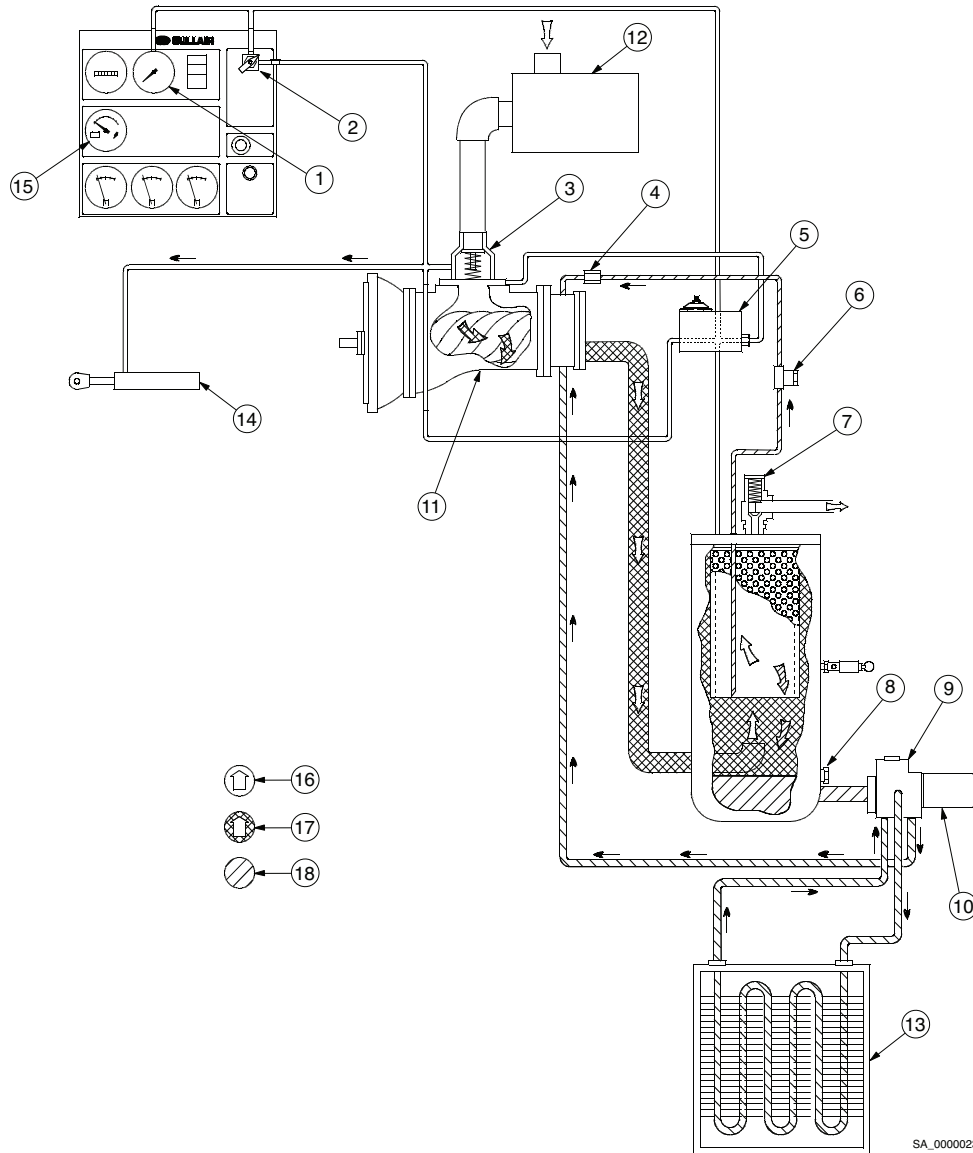

Figure 2-5: Control System with Piping and Instrumentation-260 Models

- | | |
|---------------------------------------|-----------------------------------|
| 1. Air Pressure Gauge | 10. Fluid Filter |
| 2. Idle Warm-Up Valve | 11. Compressor Unit |
| 3. Inlet Valve | 12. Air Filter |
| 4. Orifice | 13. Fluid Cooler |
| 5. Regulator/Blowdown Valve Manifold | 14. Engine Speed Control Cylinder |
| 6. Strainer | 15. Instrument Panel |
| 7. Minimum Pressure/Check Valve | 16. Air |
| 8. Fluid Fill/Fluid Level Sight Glass | 17. Fluid/Air |
| 9. Thermal Valve | 18. Fluid |

SECTION 2

225H AND 260 USER MANUAL R00

1. FILTER, AIR
 2. GAUGE, FILTER RESTRICTION (OPTIONAL)
 3. INLET VALVE
 4. COMPRESSOR
 5. GAUGE, TEMPERATURE
 6. SWITCH, TEMPERATURE
 7. VALVE, RELIEF
 8. RECEIVER, AIR/OIL
 9. GLASS, SIGHT OIL LEVEL
 10. VALVE, MINIMUM PRESSURE/CHECK
 11. VALVE, BALL
 12. SPEED CONTROL CYLINDER
 13. REGULATOR/BLOWDOWN MANIFOLD
 14. ORIFICE
 15. VALVE, BLOWDOWN N.C.
 16. STRAINER
 17. VALVE, THERMAL BYPASS
 18. COOLER, OIL
 19. FILTER, OIL
 20. GAUGE, PRESSURE
 21. VALVE, PRESSURE REGULATOR
 22. VALVE, 3-WAY SELECTOR
 23. VALVE, CHECK
 24. HIGH PRESSURE MACHINES ONLY
- T1 COMPRESSOR DISCHARGE TEMPERATURE SWITCH

2.8 PIPING AND INSTRUMENTATION—ENGINE SYSTEM

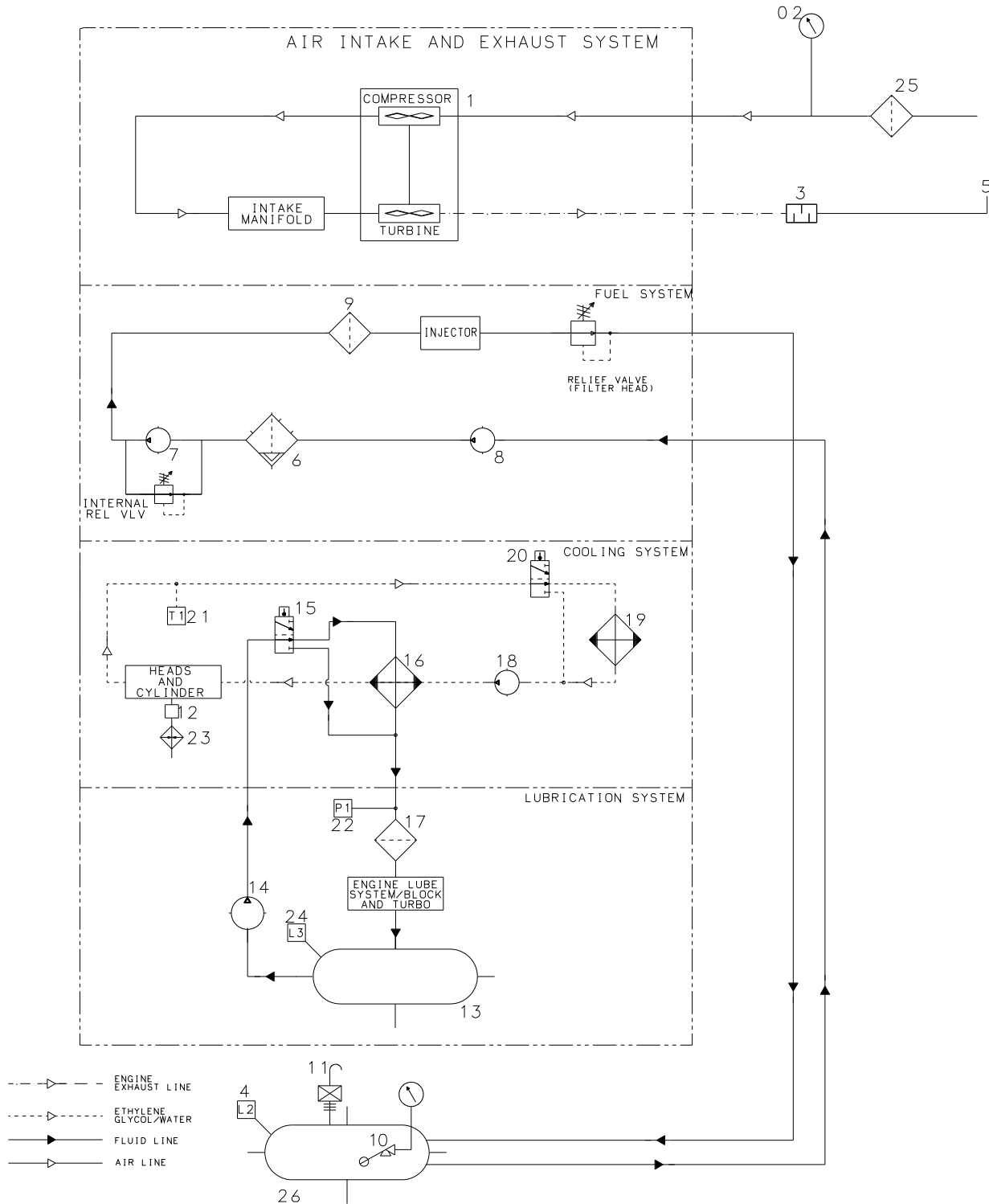

SECTION 2

225H AND 260 USER MANUAL R00

1. TURBOCHARGER, COMPRESSOR
 2. GAUGE FILTER RESTRICTION
 3. MUFFLER, ENGINE
 4. FUEL LEVEL SENDER
 5. RAIN CAP, EXHAUST SYSTEM
 6. FUEL FILTER W/ WATER SEPARATOR
 7. FUEL TRANSFER PUMP
 8. HAND OPERATED FUEL PRIMING PUMP
 9. FILTER, FUEL
 10. GAUGE, FUEL LEVEL
 11. FUEL TANK CAP W/VENT
 12. THERMOSTAT, THERMOCORD (OPTIONAL)
 13. ENGINE OIL PAN
 14. OIL PUMP (INTERNAL TO ENGINE)
 15. BY-PASS VALVE (INTERNAL TO ENGINE)
 16. COOLER, OIL (INTERNAL TO ENGINE)
 17. FILTER, OIL
 18. WATER PUMP (INTEGRAL TO ENGINE)
 19. RADIATOR, ENGINE
 20. ENGINE THERMOSTAT (INTEGRAL TO ENGINE)
 21. SENSOR, COOLANT TEMPERATURE
 22. SENSOR, ENGINE OIL PRESSURE
 23. JACKET WATER HEATER (OPTIONAL)
 24. FILTER, AIR
 26. TANK, FUEL
- L1 COOLANT LEVEL
L2 FUEL LEVEL
L3 OIL LEVEL (DIPSTICK)
- P1 OIL PRESSURE
- T1 COOLANT TEMPERATURE

NORMAL OPERATION – 80 TO 100 PSIG (5.6 TO 6.9 BAR) FOR STANDARD MACHINE, 80 TO 150 PSIG (5.6 TO 10.3 BAR) FOR HIGH PRESSURE ‘H’ MACHINES

When the warm-up control selector valve handle is moved to the RUN position, the air-oil receiver tank pressure rises above 80 psig (5.6 bar). At this time, the inlet valve remains fully open for maximum air output. The engine will continue to run at full speed during this phase of operation.

MODULATION – 100 TO 110 PSIG (6.9 TO 7.5 BAR) FOR STANDARD MACHINES, 150 TO 165 PSIG (10.3 TO 11.4 BAR) FOR HIGH PRESSURE ‘H’ MACHINES

If the demand on the compressor is less than its rated capacity, the service line pressure will rise above 100 psig (6.9 bar) or 150 psig (10.3 bar) for high pressure ‘H’ machines. The pressure regulating valve gradually opens, applying pressure to the inlet valve piston and engine speed control. This causes the inlet valve to partially close and reduces the engine speed. As the pressure increases, the inlet valve piston will further close the inlet valve and the engine speed will decrease until it reaches its preset idle speed.

When the demand on the compressor increases, the air-oil receiver tank pressure falls below 110 psig (7.6 bar) or 150 psig (10.3 bar) for high pressure ‘H’ machines. The pressure regulating valve closes, the air inlet valve opens fully, and the engine speed increases to its preset full load rating.

Between the pressure regulating valve and the inlet valve, there is a small orifice that vents a small amount of air into the atmosphere when the pressure regulating valve is open. This allows changes in air output to conform to air demand. This orifice also discharges any accumulated moisture from the regulator.

SHUTDOWN

To shutdown the machine, turn the warm-up control selector valve to ‘START’ position. Wait for pressure to reduce to about 40 psig (2.8 bar). Now press the engine switch to ‘OFF’ position.

The blowdown valve is normally closed. At shutdown the back pressure in the compressor inlet signals the blowdown valve to vent the air-oil receiver tank pressure into the atmosphere.

2.9 AIR INLET SYSTEM, FUNCTIONAL DESCRIPTION

The air inlet system consists of two air filters, one to the compressor air inlet valve and the other to the engine.

The air filters are two-stage dry element type filters that are capable of cleaning extremely dirty air. However, when operating in dirty environments, the filters should be checked more frequently.

See *Air Filter Maintenance* on page 49 for Air Filter Maintenance Procedures.

2.10 INSTRUMENT PANEL GROUP, FUNCTIONAL DESCRIPTION

Refer to *Figure 2-6* for the locations of the following indicators and controls:

1. The air pressure gauge continuously monitors the air-oil receiver tank pressure under various load conditions.
2. The engine switch energizes the system and starts the compressor. The engine switch is pressed to the ON position to energize the electrical system, and pressed momentarily to the START position to engage the starter and start the compressor.
3. The idle warm-up control is turned from START to RUN after sufficient warm-up is achieved for full compressor operation.
4. The shutdown indicator light indicates engine and compressor safety shutdown status.
5. The hourmeter indicates the cumulative hours of operation.
6. The cold weather starting aid glow plugs should be used for starting in cold weather. Press the button and hold for 10-30 seconds (depending upon ambient temperature). Release the button prior to starting.
7. The optional engine voltage gauge monitors the voltage level of the engine storage battery.
8. The optional engine oil pressure gauge monitors the pressure of the lubricating oil in the engine.
9. The optional engine coolant temperature gauge monitors the temperature of the engine coolant in the engine.
10. The optional tachometer monitors the operating speed of the engine.
11. The optional fuel level gauge indicates the fluid level in the fuel tank.
12. The optional compressor discharge temperature gauge monitors the temperature of the air/oil mixture in the air oil receiver tank.



WARNING

DO NOT use aerosol types of starting aids such as ether. Such use could result in an explosion and personal injury. If the engine fails to start within 30 seconds, release the starter switch and wait two minutes to allow the starting motor to cool before attempting to start the engine again.

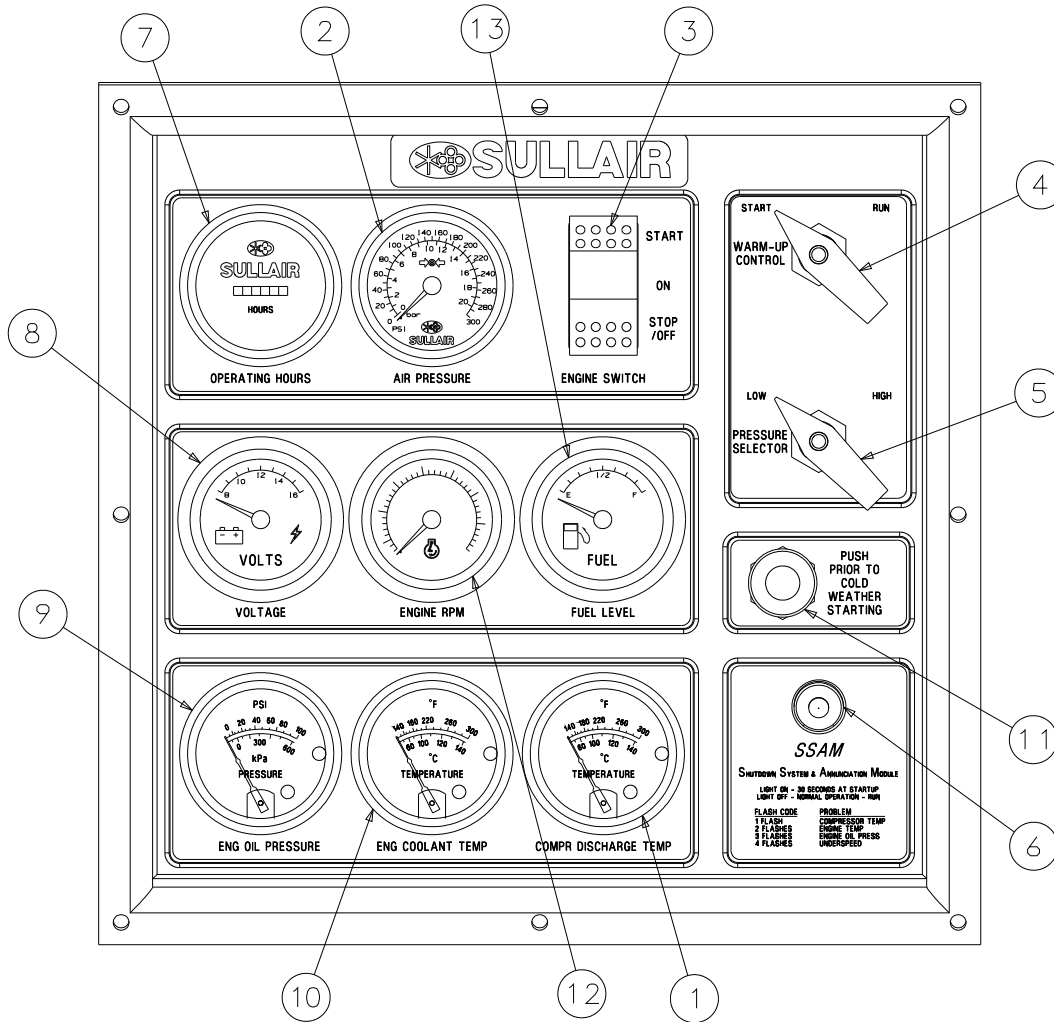
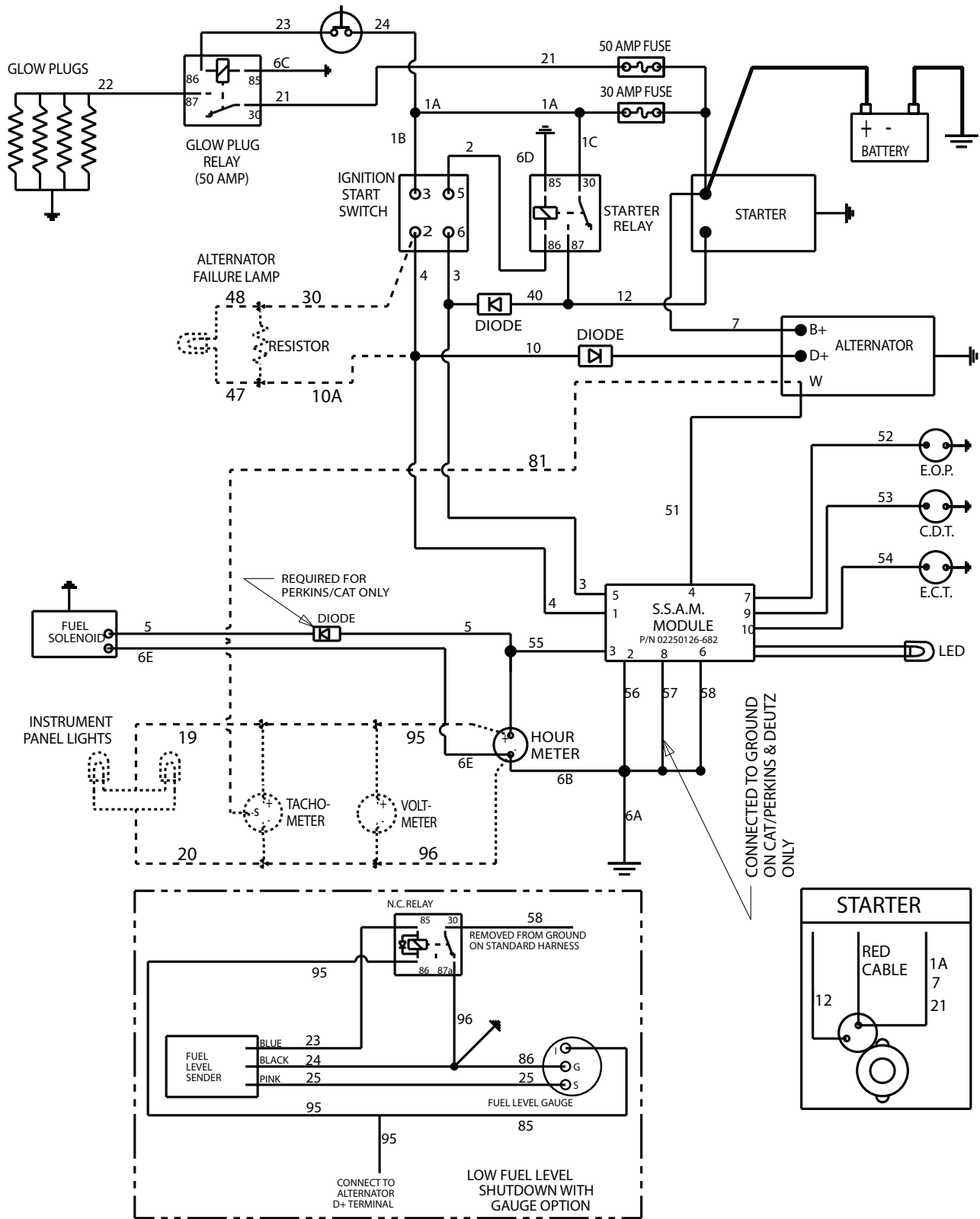

Figure 2-6: High Pressure Instrument Panel

- | | |
|---|---|
| 1. Compressor discharge temperature | 8. Engine voltage (optional) |
| 2. System air pressure | 9. Engine oil pressure (optional) |
| 3. Start stop switch | 10. Engine coolant temperature (optional) |
| 4. Warm-up control | 11. Cold weather starting (glow plugs) |
| 5. High/low pressure selector (225H only) | 12. Engine RPM (optional) |
| 6. Warning indicator | 13. Fuel level (optional) |
| 7. Hourmeter | |

2.11 WIRING DIAGRAM—JD & DEUTZ



2.12 WIRING DIAGRAM—CAT

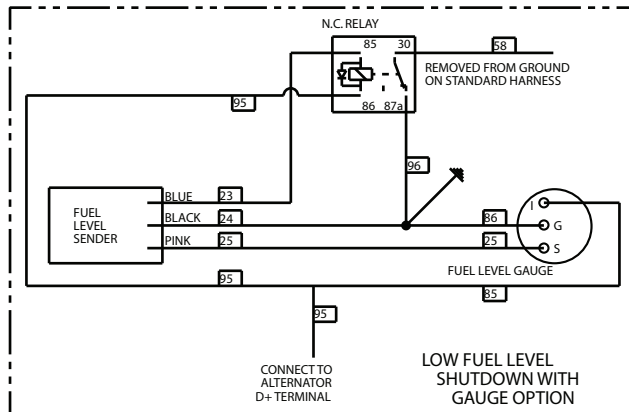
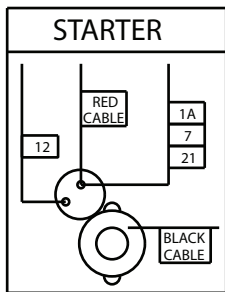
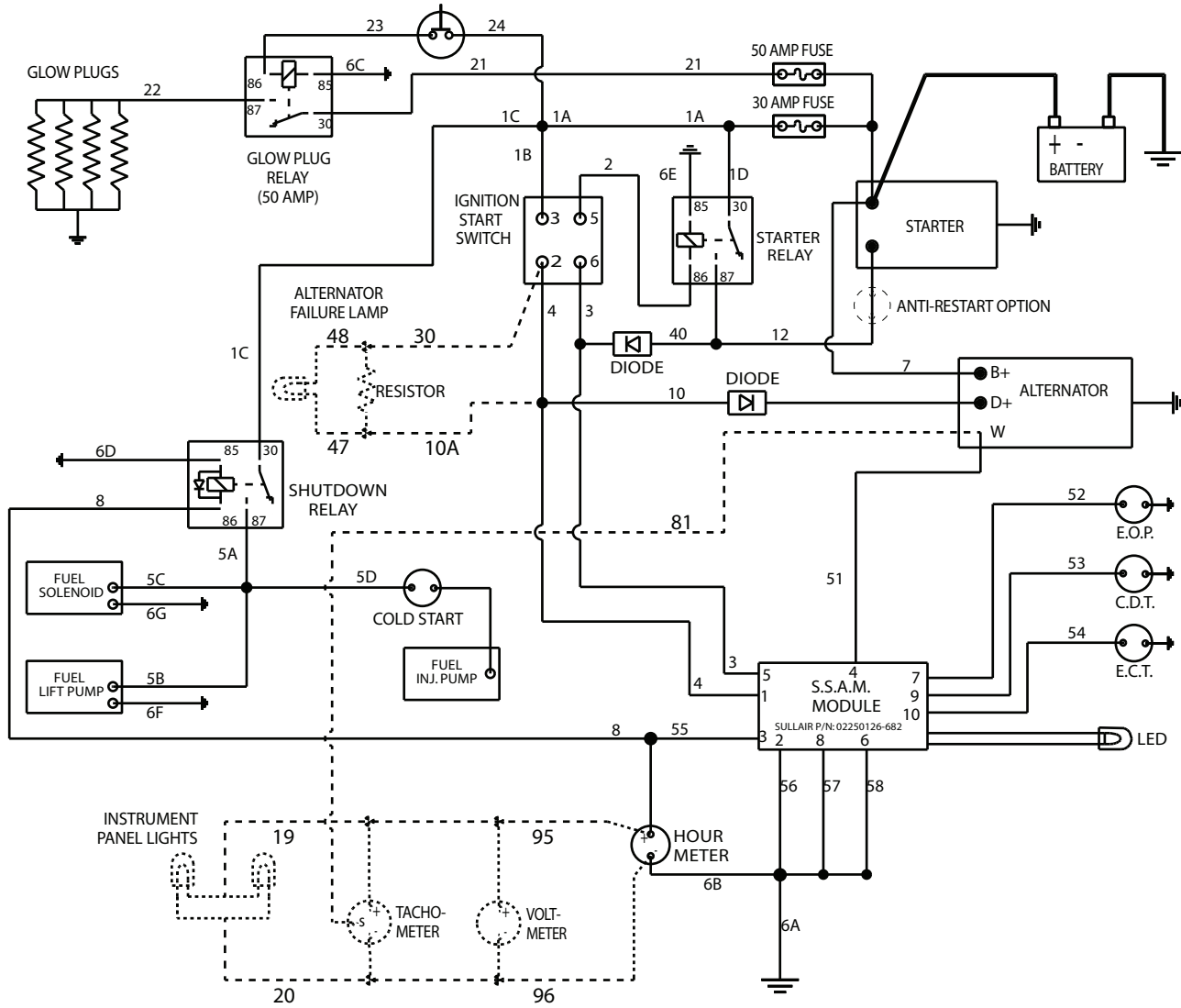

2.13 ELECTRICAL SYSTEM, FUNCTIONAL DESCRIPTION

The electrical system consists of the basic electrical elements required to operate the compressor and also has a system feature that automatically shuts down the compressor when a malfunction occurs. The system's components include: an engine starter, battery, alternator/ voltage regulator, and a fuel solenoid. It also has a compressor discharge temperature switch that will shut the compressor down if the compressor temperature exceeds 250° F (121° C). It has an engine water temperature switch set to shut down the compressor when the coolant temperature reaches 225° F (107° C) and an oil pressure switch that will shut down the compressor if the engine oil pressure goes too low. An underspeed sensor shuts down the compressor if the engine speed falls below 1500 rpm.

2.14 COMPRESSOR SHUTDOWN & WARNING SYSTEM, FUNCTIONAL DESCRIPTION

The Shutdown System and Annunciator Module (SSAM) continuously monitors the status of the compressor. In the event of a shutdown condition, the SSAM will shut down the compressor and display (flashing) the appropriate code on the instrument panel annunciator light. The display will continue flashing until the ignition switch is turned OFF. The shutdown codes are:

- One flash: high compressor discharge temperature
- Two flashes: high engine coolant temperature
- Three flashes: low engine oil pressure
- Four flashes: low engine speed
- Five flashes: low fuel level (optional)

The SSAM also provides startup logic for the compressor. When the ignition switch is in the ON position, the annunciator light will illuminate for 30 seconds. During this 30 second period, pressing the ignition switch will engage the engine starter. The low engine speed switch is inactive during this startup time interval. By the end of these 30 seconds, the annunciator light goes out and the engine START cycle is disabled. At this time the system runs all safety checks including low fuel level (if installed).

NOTES

Section 3

SPECIFICATIONS

3.1 SPECIFICATIONS – 225H AND 260 JOHN DEERE

Table 3-1: Overall Specifications—John Deere

Model Series	Length ¹		Width		Height		Weight (wet) ²	
	in	mm	in	mm	in	mm	lb	kg
225H and 260 2-Wheel	143.3	3640	65.4	1661	59.9	1521	2840	1288
225H and 260 Less Running Gear	85.1	2162	47.5	1207	49.0	1245	2585	1173

¹ Length over drawbar for 2 – wheel version
² Weight shown is for 260 model. Deduct 120 pounds (55 kg) for 225H models.

Table 3-2: Compressor Specifications—John Deere

Compressor	225H	260
Type	Rotary Screw	Rotary Screw
Maximum Operating Pressure	150 psig (8.6 bar)	125 psig (8.6 bar)
Pressure Delivery	225 Free CFM (106 L/S)	260 Free CFM (123 L/S)
Rated Pressure	150 psig (8.6 bar)	100 psig (6.9 bar)
Cooling	Pressurized Compressor Fluid	Pressurized Compressor Fluid
Lubricating Compressor Fluid	See <i>Section 3.4</i>	See <i>Section 3.4</i>
Sump Capacity	3 US gallons (11 liters)	5 US gallons (18.9 liters)
Track Width	55.0" (1387 mm)	55.0" (1387 mm)
Tire Size (Load Range)	F78 x 15 (C)	F78 x 15 (C)
Tire Pressure	50 psig (3.5 bar)	50 psig (3.5 bar)
Wheel Size	15 x 5	15 x 5
Lug Nut Torque	60 ft-lbs (81 Nm)	60 ft-lbs (81 Nm)
Operating Tilt (maximum)	15°	15°
Electrical System	12 volt	12 volt
Compressor Discharge Temperature Shutdown	250°F (121°C)	250°F (121°C)
Service Valves	(2) 3/4"	(2) 3/4"
Maximum Towing Speed	55 mph (88 kmph)	55 mph (88 kmph)
Axle Rating	3500 lbs. (1588 kg)	3500 lbs. (1588 kg)
Sound Level (US EPA)	76 dBA at 7 m	76 dBA at 7 m

Table 3-3: Engine Specifications—John Deere

Engine	225H	260
Type	Diesel	Diesel
Make	John Deere	John Deere
Model	5030TF270	5030TF270
Emission Level	U.S. EPA Tier 2 European Stage II	U.S. EPA Tier 2 European Stage II
Displacement	201 cu-in (3.3 L)	201 cu-in (3.3 L)
Cylinders	4	4
Bore x Stroke	3.40 x 4.10 in (86.0 x 105.0 mm)	3.40 x 4.10 in (86.0 x 105.0 mm)
Rated Speed	2500 RPM	2500 RPM
Rated Power	81.0 HP (60.1 kW)	81.0 HP (60.1 kW)
Type of Motor Oil	See Engine Operator Manual	See Engine Operator Manual
Fuel Tank Capacity	35 Gallons (132 liters)	35 Gallons (132 liters)
Radiator Capacity	2.5 US Gallons (9.5 liters)	2.5 US Gallons (9.5 liters)
Engine Water Temperature	Shutdown 225°F (107°C)	Shutdown 225°F (107°C)
Minimum Idle Speed	1800 RPM ¹	1800 RPM ¹
Alternator Rating	70 amp	70 amp
¹ DO NOT allow engine idle rpm to drop below minimum idle speed. Compressor and/or coupling damage will occur. The compressor is equipped with a Low Speed Shutdown System that will shutdown the compressor if engine speed falls below 1500 rpm.		

3.2 SPECIFICATIONS – 225H AND 260 DEUTZ

Table 3-4: Overall Specifications—Deutz

Model Series	Length ¹		Width		Height		Weight (wet) ²	
	in	mm	in	mm	in	mm	lb	kg
125, 130 and 185 2-Wheel	130.8	3322	59.2	1504	53.8	1368	2130	966
125, 130 and 185 Less Running Gear	69.1	1765	40.9	1040	41.7	1060	1885	855

¹Length over drawbar for 2 – wheel version
²Weight shown is for 260 model. Deduct 120 pounds (55 kg) for 225H models.

Table 3-5: Compressor Specifications—Deutz

Compressor	225H	260
Type	Rotary screw	Rotary screw
Maximum Operating Pressure	150 psig (10.3 bar)	100 psig (6.9 bar)
Delivery, Free Air	225 cfm (106 l/s)	260 cfm (122 l/s)
Rated Pressure	150 psig (10.3 bar)	100 psig (6.9 bar)
Cooling	Oil circulation	Oil circulation
Lubricating Compressor Fluid	See lubrication guide	See lubrication guide
Sump Capacity	3.0 gal (11.4 liters)	3.0 gal (11.4 liters)
Track Width	55 in. (1397 mm)	55 in. (1397 mm)
Tire Size (Load Range), Each	1820 lb (825.5 kg)	1820 lb (825.5 kg)
Tire Pressure	50 psig (3.5 bar)	50 psig (3.5 bar)
Wheel Size	15x5	15x5
Lug Nut Torque	60 ft-lb (81 Nm)	60 ft-lb (81 Nm)
Operating Tilt (maximum)	15 degrees	15 degrees
Electrical System	12 volt	12 volt
Compressor Discharge Temperature Shutdown	250°F (121°C)	250°F (121°C)
Service Valves	(2) 3/4"	(2) 3/4"
Maximum Towing Speed	55 mph (88kmph)	55 mph (88kmph)
Axle Rating	3500 lb (1588 kg)	3500 lb (1588 kg)
Sound Level (US EPA)	76 dBa at 7m	76 dBa at 7m

Table 3-6: Engine Specifications—Deutz

Engine	225H	260
Type	Diesel	Diesel
Make	Deutz	Deutz
Model	TD 2011 L4	TD 2011 L4
Emission Level	EPA Tier 3 Nonroad	EPA Tier 3 Nonroad
Displacement	221 cu. in. (3.62L)	221 cu. in. (3.62L)
Cylinders	4	4
Bore x Stroke	3.77x4.92 in (96mm x 125mm)	3.77x4.92 in (96mm x 125mm)
Rated Speed	2500 RPM	2500 RPM
Rated Power	88HP (66kw)	88HP (66kw)
Type of Motor Oil	See Engine Operators Manual	See Engine Operators Manual
Fuel Tank Capacity	3.5 gal (132 liters)	3.5 gal (132 liters)
Radiator Capacity	3 gal (11.4 liters)	3 gal (11.4 liters)
Engine Water Temperature Shutdown	225°F(107°C)	225°F(107°C)
Minimum Idle Speed	1900 RPM	1900 RPM
Alternator Rating	50 amp	50 amp
<p>¹ DO NOT allow engine idle rpm to drop below minimum idle speed. Compressor and/or coupling damage will occur. The compressor is equipped with a Low Speed Shutdown System that will shutdown the compressor if engine speed falls below 1500 rpm.</p>		

3.3 SPECIFICATIONS—225H AND 260 CATERPILLAR

Table 3-7: Overall Specifications—Caterpillar

Model Series	Length ¹		Width		Height		Weight (wet) ²	
	in	mm	in	mm	in	mm	lb	kg
225H and 260 2-Wheel	143.3	3640	65.4	1661	59.9	1521	2760	1252
225H and 260 Less Running Gear	85.1	2162	47.5	1207	49.0	1245	2505	1136

¹ Length over drawbar for 2 – wheel version
² Weight shown is for 260 model. Deduct 120 pounds (55 kg) for 225H models.

Table 3-8: Compressor Specifications—Caterpillar

Compressor	225H	260
Type	Rotary Screw	Rotary Screw
Maximum Operating Pressure	150 psig (8.6 bar)	125 psig (8.6 bar)
Pressure Delivery	225 Free CFM (106 L/S)	260 Free CFM (123 L/S)
Rated Pressure	150 psig (8.6 bar)	100 psig (6.9 bar)
Cooling	Pressurized Compressor Fluid	Pressurized Compressor Fluid
Lubricating Compressor Fluid	See Section 3.4	See Section 3.4
Sump Capacity	3 US gallons (11 liters)	5 US gallons (18.9 liters)
Track Width	55.0" (1387 mm)	55.0" (1387 mm)
Tire Size (Load Range)	F78 x 15 (C)	F78 x 15 (C)
Tire Pressure	50 psig (3.5 bar)	50 psig (3.5 bar)
Wheel Size	15 x 5	15 x 5
Lug Nut Torque	60 ft-lbs (81 Nm)	60 ft-lbs (81 Nm)
Operating Tilt (maximum)	15°	15°
Electrical System	12 volt	12 volt
Compressor Discharge Temperature	250°F (121°C)	250°F (121°C)
Service Valves	(2) 3/4"	(2) 3/4"
Maximum Towing Speed	55 mph (88 kmph)	55 mph (88 kmph)
Axle Rating	3500 lbs. (1588 kg)	3500 lbs. (1588 kg)
Sound Level (US EPA)	76 dBA at 7 m	76 dBA at 7 m

Table 3-9: Engine Specifications—Caterpillar

Engine	225H	260
Type	Diesel	Diesel
Make	Caterpillar	Caterpillar
Model	C3.4	C3.4
Emission Level	U.S. EPA Tier 3 European Stage IIIA	U.S. EPA Tier 3 European Stage IIIA
Displacement	201 cu-in (3.3 L)	201 cu-in (3.3 L)
Cylinders	4	4
Bore x Stroke	3.70 x 4720 in (94.0 x 120.0 mm)	3.70 x 4720 in (94.0 x 120.0 mm)
Rated Speed	2500 RPM	2500 RPM
Rated Power	83.0 HP (62.0 kW)	83.0 HP (62.0 kW)
Type of Motor Oil	See Engine Operator Manual	See Engine Operator Manual
Fuel Tank Capacity	35 Gallons (132 liters)	35 Gallons (132 liters)
Radiator Capacity	2.5 US Gallons (9.5 liters)	2.5 US Gallons (9.5 liters)
Engine Water Temperature Shutdown	Shutdown 230°F (110°C)	Shutdown 230°F (110°C)
Minimum Idle Speed	1800 RPM ¹	1800 RPM ¹
Alternator Rating	65 amp	65 amp
¹ DO NOT allow engine idle rpm to drop below minimum idle speed. Compressor and/or coupling damage will occur. The compressor is equipped with a Low Speed Shutdown System that will shutdown the compressor if engine speed falls below 1500 rpm.		

3.4 LUBRICATION GUIDE – COMPRESSOR

FLUID TYPE	CHANGE PERIOD/HOURS	AMBIENT TEMPERATURE RANGE °F (°C)
Sullair AWF (I)	1500	-20 to 120 (-29 to 49)
SAE 10W SE, SF, SG, CD	250	0 to 100 (-18 to 38)
MIL-L-2104E 10W	250	0 to 100 (-18 to 38)
(I) Sullair part numbers for Sullair AWF are 250030-757 (5 gallons/18.9 liters) and 250030-758 (55 gallon drum/280 liters)		

3.5 APPLICATION GUIDE

Sullair air compressors are supplied with Sullair AWF which is a heavy duty multi-viscosity, all weather fluid which provides an extended change interval when compared to other fluids. Detergent motor oils (SAE 10W Class SE, SF, SG, or CD) can also be used. Any of these oils are suitable under conditions where severe oil oxidation can occur.

Water must be drained from the receiver tank periodically. In high ambient temperature and humidity conditions, condensed moisture can emulsify with the oil forming a “milky” color. SAE 10W is especially prone to this condition. The fluid should be changed if this condition develops. DO NOT mix different fluids. Combinations of different fluids can lead to operational problems such as foaming, plugged filters, blocked orifices or lines.

When ambient conditions exceed the recommended ranges, or if other conditions warrant the use of other extended life lubricants, contact your local Sullair representative for recommendations.

Sullair encourages users to participate in a fluid analysis program. The analysis might indicate a need for change intervals different from those recommended in this manual. Sullair Corporation offers a fluid analysis for Sullair AWF. Contact Sullair for details.

D-A Lubricant® Company Inc. offers an analysis for users of Sullair AWF. Contact your Sullair representative for details.

3.6 LUBRICATION GUIDE – ENGINE

Refer to the Engine Operator’s Manual for oil specifications.

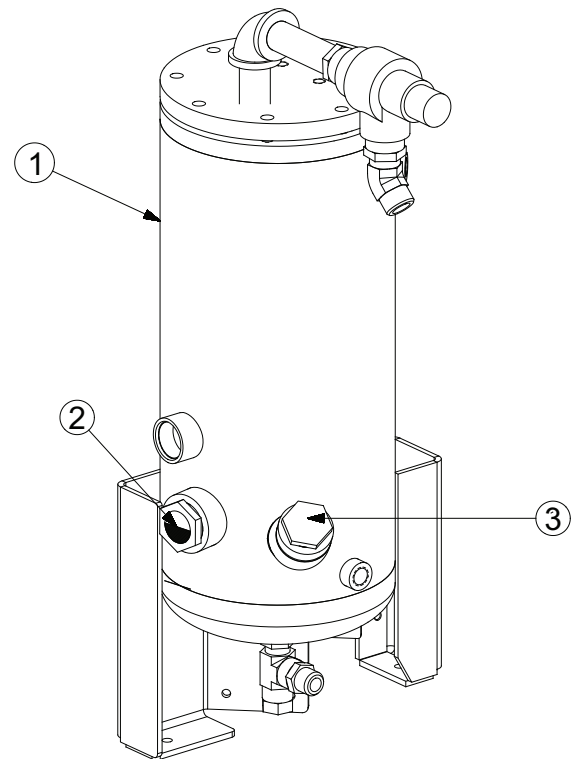

1. Receiver/Tank
2. Sight Glass
3. Fluid Fill Port

Figure 3-1: Receiver Tank (225H Tank Shown)

NOTE

Proper compressor fluid level is fluid visible halfway in sight glass when checked on a level surface with the compressor not running and on level ground.

NOTES

Section 4

GENERAL

4.1 GENERAL

While Sullair has built into this compressor a complete set of controls and indicators that allow the operator to control and monitor the compressor's operation and performance. Operators should learn to recognize indications which identify a service requirement or conditions that could lead to (or show) a (current) malfunction. Before starting the compressor, read this section thoroughly to gain familiarity with the controls and indicators – their function and location.

4.2 PURPOSE OF CONTROLS

CONTROL OR INDICATOR PURPOSE ENGINE SWITCH

Press this switch to the ON (ignition) position to energize the electrical system of the compressor. Press the switch to the START position to momentarily engage the starter and start the compressor. Press the switch to the OFF position to shut the compressor down. This switch is located on the instrument panel.

COLD WEATHER STARTING AID BUTTON

Push this button, prior to compressor start-up, to allow the engine to pre-heat for easier starting.

HOURLY METER

Indicates the accumulated hours of operation. Useful for planning and logging service schedules.

AIR PRESSURE GAUGE

Continuously monitors the pressure inside the receiver tank at various load and unload conditions.

FLUID LEVEL SIGHT GLASS

Indicates the fluid level in the receiver tank. Proper

level is marked halfway up the sight glass. Check the level when the compressor is shutdown and on level ground.

COMPRESSOR DISCHARGE TEMPERATURE SWITCH

Opens the electrical circuit to shut down the compressor when the discharge temperature reaches a specific value (See *Specifications* on page 35).

THERMAL VALVE

Functions as a temperature regulator by directing the compressor fluid either to the cooler or to the compressor unit.

MINIMUM PRESSURE DEVICE

Maintains the minimum of 80 psig (5.6 bar) in the compressor air-oil receiver tank.

PRESSURE RELIEF VALVE

Vents sump pressure to the atmosphere if pressure inside the sump exceeds 200 psig (13.8 bar).

AIR INLET VALVE

Regulates the amount of air allowed to enter the air compressor inlet. Regulation is determined by a signal from the pressure regulator(s).

PRESSURE REGULATOR

Allows the pressure signal to reach the engine speed control and the air inlet valve to control air delivery according to demand.

SHUTDOWN SYSTEM/ANNUNCIATOR MODULE (SSAM)

Monitors the compressor safety system for conditions requiring shutdown. The annunciator on the instrument control will flash the applicable shutdown code.

BLOWDOWN VALVE

Vents air-oil receiver tank pressure to the atmosphere at shutdown.

IDLE WARM-UP CONTROL SELECTOR VALVE

Keeps the compressor inlet valve closed for reduced compressor load at start-up. When the compressor is warmed-up, the handle can be turned from the START to the RUN position for full operation.

PRESSURE SELECTOR VALVE

(available on High Pressure 'H' Models)

Sets compressor operation in low pressure range from 80 to 110 psig (5.6 to 7.6 bar) or in the high pressure range from 80 to 165 psig (5.6 to 11.4 bar).

4.3 INITIAL STARTUP/ SHUTDOWN PROCEDURE

STARTUP

Perform the following actions when starting the compressor for the first time:

1. Ensure that the compressor is on a level surface. (If the compressor is on an uneven surface, the fluid sight gauge readings will not be accurate, and it will not be possible to determine if fluid levels are too low.)
2. Ensure that a minimum clearance of 3 feet is provided all the way around the machine to allow exhaust gas to ventilate before operating the machine. Failure to ventilate hot exhaust gas can result in improper functioning of the machine and heat build-up can result in melting of rubber and/or plastic components.
3. Check the oil and fluid levels in the engine and compressor: add oil and/or fluid if necessary.
4. Fill the fuel tank and drain any water from the fuel/ water separator.
5. Crack open one service line.
6. Place the WARM-UP control in the START position.
7. Place Pressure Selector Valve to low position in 'H' Models.
8. Press the ENGINE SWITCH to the ON position.
9. In cold weather, press the cold weather starting aid button. Hold button for 10 to 30 seconds and then release.
10. Momentarily press the ENGINE SWITCH to the START position to engage the starter: release the switch when the engine starts.
11. After 30 seconds (the annunciator light will go off after 30 seconds) Turn the IDLE WARM-UP SELECTOR VALVE from START to RUN to put the compressor in full operation.
12. Close all doors to maintain proper noise level.

SHUTDOWN

1. Close the service valves and turn the idle warm-up control selector valve to START position. Allow pressure to drop down to about 40 psig.
2. Press the ENGINE SWITCH to the OFF position after five minutes.

4.4 RESTART PROCEDURE

After running and shutting down the compressor for the first time, perform the following actions when restarting the compressor:

1. Check engine oil, engine coolant, and fuel levels.
2. Check the compressor fluid level (sight glass) and drain any water from the fuel/water separator.
3. Check the dust collectors and clean if necessary.
4. Crack open the service valve.
5. Place the WARM-UP SELECTOR VALVE in the START position.
6. Press the ENGINE SWITCH to the ON position.
7. Place Pressure Selector Valve to low position in 'H' Models.
8. In cold weather, press the cold weather starting aid button. Hold button for 10 to 30 seconds and then release.
9. Momentarily press the ENGINE SWITCH to the START position to engage the starter: release the switch when the engine starts.
10. After 30 seconds (the annunciator light will go off after 30 seconds) Turn the IDLE WARM-UP SELECTOR VALVE from START to RUN to put the compressor in full operation.
11. To shut down the compressor, see Shutdown procedure in previous section.



WARNING

DO NOT use aerosol types of starting aids such as ether.

Such use could result in an explosion and personal injury.

If the engine fails to start within 30 seconds, release the starter switch or button and wait for two minutes to allow the starting motor to cool before attempting to start the engine again.

NOTES

Section 5

MAINTENANCE

WARNING

DO NOT remove caps. Plugs and/or other components when the compressor is running or pressurized. Shutdown the compressor before removing any components.

5.1 GENERAL

Consistent and correctly performed maintenance will ensure the compressor's performance and extend its operational life. See *Part Replacement And Adjustment Procedures* on page 48 for a detailed description of specific compressor components. Before performing maintenance actions, read the CIMA Safety Manual, if applicable. For engine maintenance requirements and procedures, refer to the Engine Operator's Manual.

5.2 ENGINE COOLANT REQUIREMENT FOR RADIATORS

The coolant provided with Sullair portable air compressors is ethylene glycol based, 50/50 mixture, and should never be mixed with a different coolant type, color or brand. If radiator coolant is to be added, for any reason, be sure that the coolant added is the same as what is in the cooling system, as well as what is recommended. Refer to the *Maintenance* Section of the **Engine Operator's Manual** for proper engine coolant specifications and instructions. Ensure that the proper coolant is used when adding engine coolant to the machine. If you are not sure of the coolant that is installed originally or want to change to a different type, the cooling system must be cleaned with a commercial cleaning agent and completely flushed and filled with distilled water several times to remove all traces of old coolant. Then, fill the system with the recommended coolant using only one brand/type. Cross contamination which is caused by adding different types of engine coolants may result in the coolant additives to deplete (dropout); thus leaving radiator surfaces unprotected.

Corrosion to radiator surfaces may occur, thus reducing radiator life expectancy. It is extremely important to evacuate/purge all air within the cooling system before replacing the radiator cap.

5.3 DAILY MAINTENANCE

See Initial Startup Shutdown/Procedure for general operation.

CAUTION

The radiator and engine cooling system must be drained and flushed periodically. Refer to the OEM Engine Manual for more information. Replace the coolant with a solution of 50% ethylene glycol and 50% water or as required for your geographic location. DO NOT use a leak sealing type of antifreeze. Should a 100% water solution be used, a non-chromate rust inhibitor must be added. DO NOT mix coolant types.

NOTE

Dispose of fluids in accordance with applicable federal, state and local regulations.

5.4 MAINTENANCE AFTER INITIAL 50 HOURS OF OPERATION

After the initial 50 hours of operation, the following maintenance actions are required to eliminate contaminants from the system:

1. Clean the return line orifice and change the strainer.
2. Change the compressor fluid filter.

3. Check the Engine Operator's Manual for service requirements.
4. Check the fuel filter for water.
5. Confirm that the receiver tank cover bolts are tightened to 60 lb-ft (81N•m).

5.5 MAINTENANCE EVERY 50 HOURS

1. Inspect air filter elements and replace if necessary.
2. Check the fuel filter for water.

5.6 MAINTENANCE EVERY 100 HOURS

1. Clean the radiator and cooler exterior surfaces.
2. Check the Engine Operator's Manual for service requirements.

5.7 MAINTENANCE EVERY 250 HOURS

1. Check fan belt tension.
2. Clean the radiator and cooler exterior surfaces. (Where dust and other atmospheric contaminants are present, it might be necessary to clean these parts more frequently.)
3. Check the Engine Operator's Manual for service requirements.
4. Change the engine oil and filter.
5. Change the compressor fluid if it is not Sullair AWF.

NOTE

The fluid change period varies by fluid brand. Refer to Section 3.4.

6. Clean or replace the return line strainer.
7. Change the air filter primary elements.
8. Change the compressor fluid filter.
9. Clean the return line orifice.

10. Change the fuel filter. (If the filter tends to clog more often than what is expected, change the filter more frequently.)
11. Change the engine fuel/water separator.
12. Check the engine rpm idle speed. The idle speed should be at the specified minimum idle speed listed in *Section 3*.



WARNING

Operating the compressor below its minimum specified idle speed will damage the compressor. Operating the compressor in this condition will cause coupling and/or compressor failure.

5.8 MAINTENANCE EVERY 1500 HOURS

1. If the compressor fluid is Sullair AWF, change the fluid and replace the fluid filter element. (See *Compressor Fluid Filter Element Replacement* on page 49.)
2. Service the engine cooling system.
3. Lubricate axle bearings on wheel-mounted units.

5.9 PART REPLACEMENT AND ADJUSTMENT PROCEDURES

COMPRESSOR FLUID CHANGE PROCEDURE

1. Run the compressor five to ten minutes to warm up the fluid.
2. Shut the compressor down and relieve all internal pressure.
3. Drain the air-oil receiver tank by removing the plug, or opening the valve at the bottom of the sump tank.
4. Change the compressor fluid and replace the fluid filter element (For element replacement see the filter servicing procedure in this Section.)
5. Fill the air-oil receiver tank with fluid in accordance with the specifications in *Section 3*.

COMPRESSOR FLUID FILTER ELEMENT REPLACEMENT

Refer to *Figure 5-1*.

1. Remove the old element with a strap wrench.
2. Clean the gasket seating surface.
3. Apply a light coating of fluid to the new gasket.
4. Hand tighten the new element until the new gasket is seated.
5. Continue tightening the element by hand an additional $\frac{1}{2}$ to $\frac{3}{4}$ turn.
6. Restart the compressor and check for leaks.

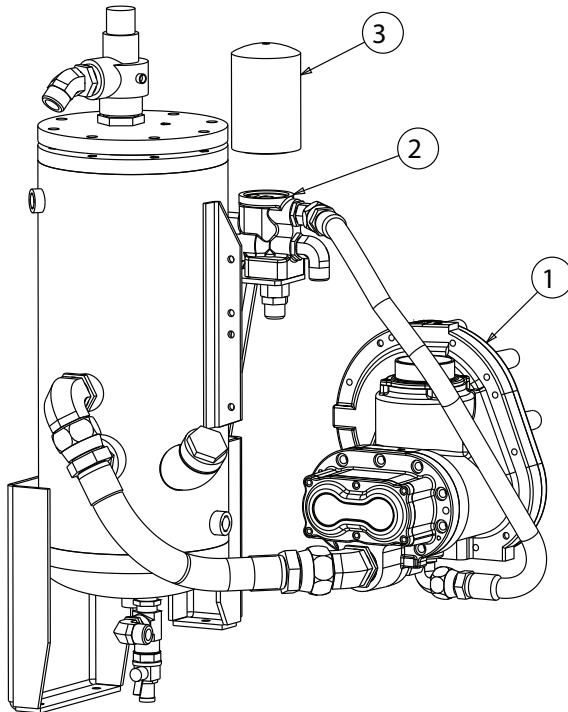

Figure 5-1: Compressor Fluid Filter

1. Compressor Unit
2. Thermal Valve Manifold
3. Fluid Filter Element
P/N 250028-032

AIR FILTER MAINTENANCE

Refer to *Figure 5-2*. Air filter maintenance should be performed as often as conditions require. If the filters are equipped with optional maintenance indicators, change the filters every time the indicators show a change is necessary.

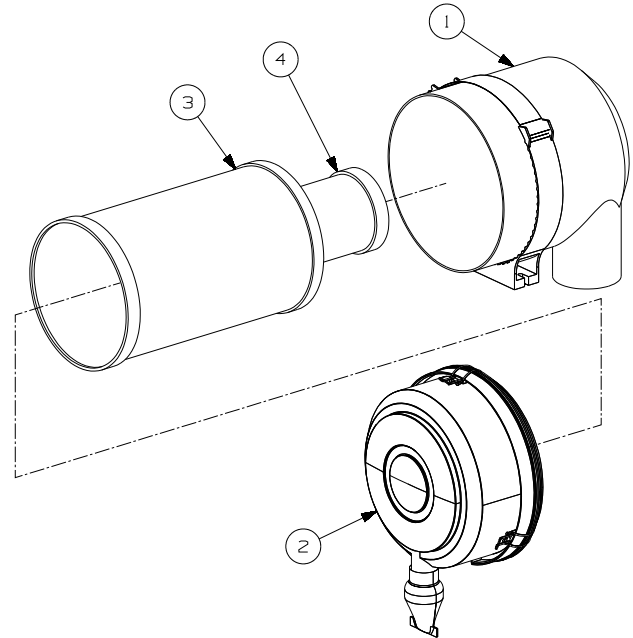

Figure 5-2: Air Filter

1. Filter Body
2. Filter Cover
3. Primary Element
Replacement Primary Element
P/N 02250125-372
4. Optional Safety Element
Optional Replacement Safety Element
P/N 02250122-817

AIR FILTER REPLACEMENT

1. Loosen and remove the air filter and cover.
2. Remove the primary and optional secondary elements.
3. Clean the body, inside and out, with a damp cloth.
4. Reinstall (if clean) or replace the secondary element if installed.
5. Replace the new primary filter element.

6. Reposition the cover and lock it into the position.
7. Reset the filter restriction indicator (if equipped).

ELEMENT INSPECTION

1. Insert a bright light source into the element and look for any light leaks which indicate the presence of damage (holes, cracks, etc.)
2. Inspect all gaskets and gasket contact surfaces of the housing and replace any damaged ones.
3. Store clean elements for later use in a clean container.
4. After installing the element, inspect and tighten all air inlet connections before operating the compressor.

SEPARATOR ELEMENT REPLACEMENT

Refer to *Figure 5-3*. When compressor fluid carryover is evident, after replacing or inspecting the fluid return line strainer and orifice, and the blowdown valve; and all are in satisfactory condition, the separator element must be replaced with the Kit number shown in *Figure 5-3*.

1. Disconnect all sump cover piping connections to permit removal (return line, service line, etc.).
2. Remove the fluid return line from the fitting on the cover.
3. Remove the eight (8) cover bolts and washers and lift the cover off the sump.
4. Remove the separator element.
5. Scrape the old gasket material from the cover and the flange on the sump. Do not allow the scrapings to fall into the tank.
6. Install the new element.
7. Replace the sump cover and bolts. Lightly tighten all the bolts and then gradually tighten them alternating between bolts which are diagonally opposite each other. Torque the bolts to 60 ft-lbs (81 N•m).

8. Reconnect all piping. The fluid return line tube should extend to the bottom of the separator element which will ensure proper return line flow.
9. Clean the fluid return line strainer and clear the orifice before starting the compressor.
10. After 24 hours of operation, re-tighten the separator tank cover bolts to the value given in step 7.

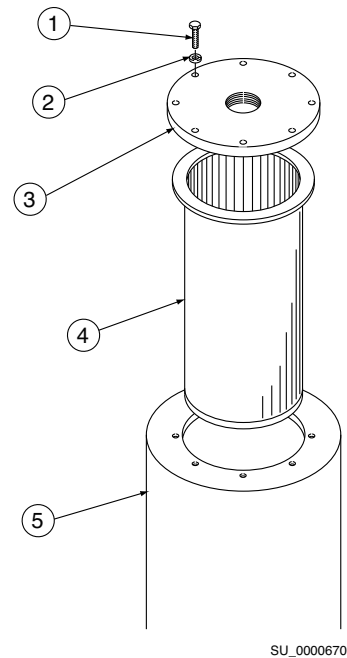

SU_0000670

Figure 5-3: Air/Fluid Separator

1. Capscrew
2. Washer
3. Cover
4. Separator Element with Gaskets
5. Receiver Tank

Air/Fluid Separator Element

P/N 250034-112 (225H)

P/N 02250078-031 (260)

PROCEDURE FOR SETTING SPEED AND PRESSURE CONTROLS ON PORTABLE COMPRESSORS EQUIPPED WITH POPPET VALVES

Refer to *Figure 5-4* and *Figure 5-5*. Before adjusting the compressor's control system, the rated full-load pressure and the high/low rpm settings must be determined. This information is provided in *Section 3* or can be obtained by contacting a Sullair representative.

The following procedure applies to a compressor with full-load pressure rating of 100 psig (6.9 bar).

1. Start the compressor and allow the engine to warm-up to its normal operating temperature with the service valve closed.

2. With the service valve closed, set the engine low speed (idle) to its specified setting with the idle stop screw on the engine injector pump.

WARNING

Operating the compressor below its minimum specified idle speed will damage the compressor. Operating the compressor in this condition will cause coupling and/or compressor failure.

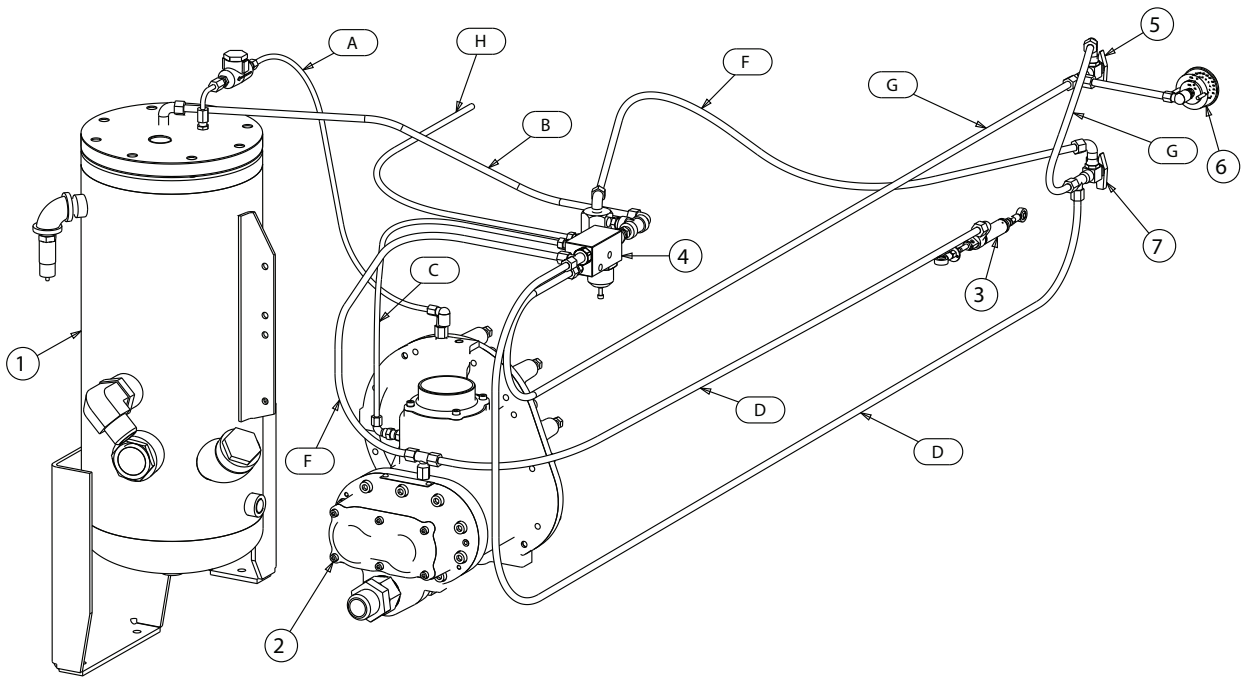

Figure 5-4: Control System Adjustment — High Pressure (225H Model)

- | | |
|---|---|
| 1. Receiver Tank | A. .25 OD White |
| 2. Compressor Unit | B. .38 OD Blue |
| 3. Engine Speed Control Cylinder | C. .25 OD Black |
| 4. Pressure Regulator/Blowdown Manifold | D. .38 OD Green |
| 5. Warm-up Control Valve | E. .38 OD Orange |
| 6. Air Pressure Gauge | F. .38 OD Yellow |
| 7. Hi-Low Pressure Valve | G. .38 OD Red |
| | H. .31 OD White (To fitting at unit air filter) |

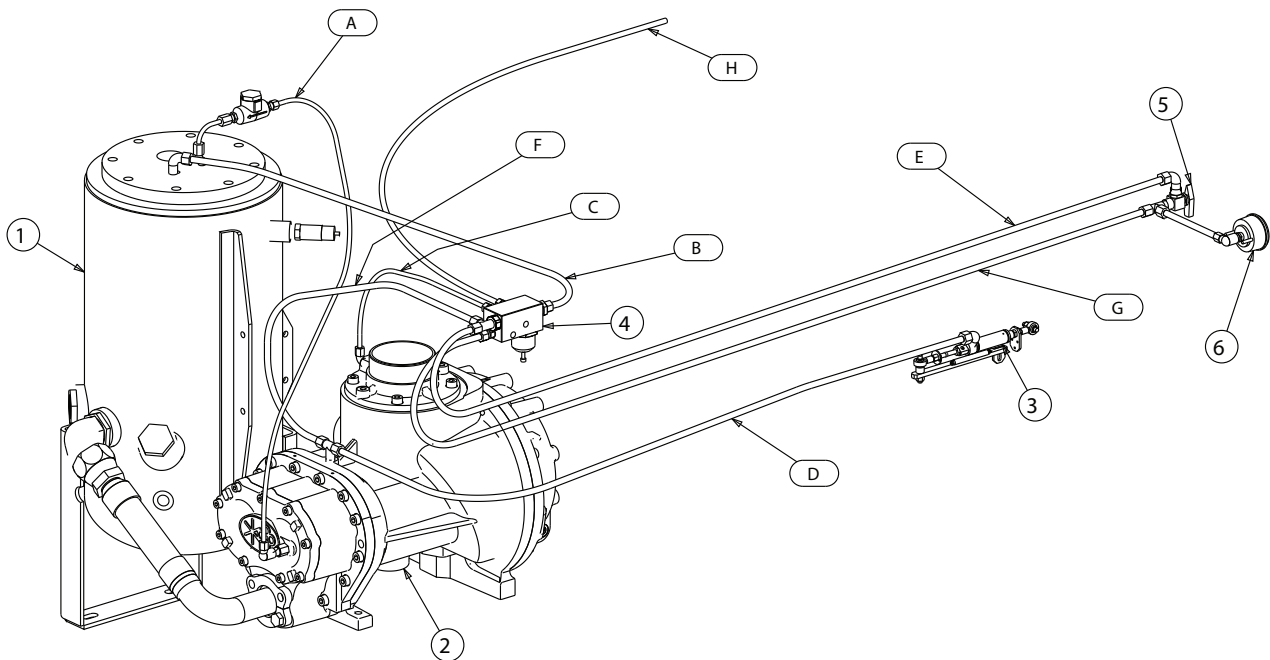

Figure 5-5: Control System Adjustment—Standard pressure (260 Model)

- | | |
|---|---|
| 1. Receiver Tank | F. .25 OD White |
| 2. Compressor Unit | G. .38 OD Blue |
| 3. Engine Speed Control Cylinder | H. .25 OD Black |
| 4. Pressure Regulator/Blowdown Manifold | I. .38 OD Green |
| 5. Warm-up Control Valve | J. .38 OD Orange |
| 6. Air Pressure Gauge | K. .38 Yellow |
| | L. .38 OD Red |
| | M. .31 OD White (To fitting at unit air filter) |

3. Adjust the pressure regulator so that the compressor maintains 115 psig (8 bar).
4. Gradually open the service valve to atmosphere until the engine comes up in speed and sump pressure is held at 100 psig (6.9 bar). At this point, set the engine high speed to its specified setting by adjusting the high idle threaded rod located on the engine speed control. To raise or lower the speed, lengthen or shorten the rod respectively.
5. Open the service valve to 100 psig (6.9 bar) (rated full load pressure) and recheck top engine speed and control response. Close the service valve and allow the compressor

to cycle and re-check low engine speed (idle).

The following steps apply to high pressure 'H' machines equipped with dual pressure controls.

1. Start the compressor and allow the engine to warm up to its normal operating temperature with the service valve closed and the pressure selector valve set to the LOW position.
2. Follow the procedure for setting the controls to 100 psig (6.9 bar) rated full load pressure as described in preceding steps 2 through 5.
3. Turn the pressure selector valve to the HIGH position with the service valve closed.

4. Adjust the high pressure regulator so that the compressor maintains a receiver tank pressure of 165 psig (11.4 bar) on 'H' models.
5. Gradually open the service valve to atmosphere until the engine speed increases and the receiver tank pressure stabilizes at 150 psig (10.3 bar) on 'H' models. At this point the engine should be operating at its rated speed. If necessary, to raise or lower speed, lengthen or shorten the rod respectively.

BEARING LUBRICATION

Refer to *Figure 5-6*. Proper lubrication of the portable compressor's bearing axle is critical to its proper function and reduction of wear on this part. Wheel bearings should be lubricated at least every 12 months, or more, to ensure proper performance and minimize wear. Use a wheel bearing grease that conforms to MILSPEC MIL-G-10924 or a high temperature one such as lithium complex NLGI consistency #2.

Axles with the E-Z Lube feature can be periodically

lubricated without removing the hubs from the axle. This feature consists of axle spindles that have been fitted with a grease zerk in their ends. When grease is pumped into the zerk, it is channeled to the inner bearing and then flows back to the outer bearing, and then back out of the grease cap hold (see *Figure 5-6*).

1. Remove the rubber cap from the grease cap's end.
2. Using a full charged grease gun, place the gun onto the grease zerk located on the end of the spindle. Make sure the nozzle is fully engaged on the fitting.
3. Pump grease into the zerk. The old grease will be displaced and flow out of the cap around the grease gun nozzle.
4. When the new grease starts flowing out of the cap, disengage the gun and wipe off any excess off the cap; and replace the rubber plug.

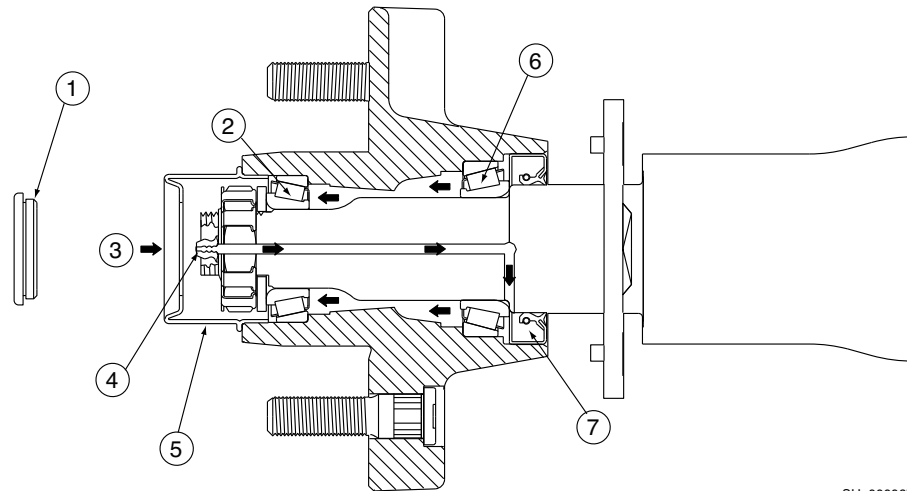

SU_0000671

Figure 5-6: Typical E-Z Lube Axle

- | | |
|-------------------|----------------------------------|
| 1. Rubber Plug | 5. Metal End Cap |
| 2. Outer Bearing | 6. Inner Bearing |
| 3. Grease Flow | 7. Spring Loaded Double Lip Seal |
| 4. Grease Fitting | |

5.10 TROUBLESHOOTING

The following Troubleshooting chart is based upon data obtained from factory tests and information from the field. It lists symptoms, probable causes and remedies. This chart does not cover all possible malfunctions or cases of abnormal operation. Before undertaking repairs or replacement actions, analyze all of the available data.

Performing a detailed visual inspection in all cases can prevent additional damage or abnormal operation.

Always:

1. Check for loose wiring or connections.
2. Check for damaged piping.
3. Check for heat damage to parts (electrical short circuits can cause heat damage) which can appear as discolorations or the presence of a burnt odor.

If the troubleshooting remedy does not work, or the malfunction is not covered in this Troubleshooting chart, contact your nearest Sullair representative or Sullair for technical assistance.

Table 5-1: Troubleshooting

ENGINE STOPS, DOES NOT CRANK OR CRANKS BUT DOES NOT START		
SYMPTOM	PROBABLE CAUSE	REMEDY
NO SSAM FLASH CODE	Low voltage or battery disconnected	Check battery cables and tighten if loose
		Check ground wire for proper attachment to frame. Tighten if required.
		Recharge or replace battery if required.
	Blown fuse in wiring harness	Remove and inspect fuse. Replace if necessary.
	Instrument panel connectors loose or disconnected.	Check instrument panel connectors and reattach if required
		Check instrument panel wires for broken connections or corrosion. Clean and/or replace if damaged.
Faulty SSAM module	Replace the module	
SSAM FLASH CODE: ONE FLASH	Compressor temperature switch is open	Check wiring connection to the switch and tighten if loose
		Check switch continuity to ground and replace if necessary
	Low receiver tank fluid level	Add fluid to receiver tank as required
	Loose or broken fan belt	Tighten or replace belt
	Cooling air flow is insufficient, dirty fluid cooler core	Clean core thoroughly and check for proper ventilation
	Clogged compressor fluid filter	Change fluid filter element
	Faulty fluid thermostat	Change fluid thermostat element
	Plugged fluid cooler tube (internal)	Replace cooler

Table 5-1: Troubleshooting

ENGINE STOPS, DOES NOT CRANK OR CRANKS BUT DOES NOT START		
SYMPTOM	PROBABLE CAUSE	REMEDY
SSAM FLASH CODE: TWO FLASHES	Engine coolant temperature switch is open	Check wiring connection to the switch and tighten if necessary
		Check switch continuity to ground and replace if necessary
	Cooling air flow is insufficient	Clean cooler and check for proper ventilation
	Loose or broken fan belt	Tighten or replace belt
	Low engine coolant	Fill with proper water/glycol mixture as required
	Faulty water pump	Change pump
	Defective engine thermostat	Change thermostat element
	Engine problems might be present	Refer to the Engine Operator's Manual
SSAM FLASH CODE: THREE FLASHES	Engine oil pressure switch is open	Check wiring connection to switch and tighten if necessary
		Install gauge in parallel with the switch. Replace the switch if the pressure exceeds 15 psig and stays open. If the pressure is less than 15 psig, refer to the Engine Operator's Manual.
SSAM FLASH CODE:FOUR FLASHES	Did not start compressor within the 30 seconds from turning the ignition switch to the ON position	"After turning the ignition switch to the ON position, press the switch to the START position within 30 seconds"
	Low battery voltage	Check the battery cables and tighten if necessary
		Recharge or replace battery if necessary
	No fuel	Refuel
	Water or dirt in the fuel and/or filter	Drain water from the fuel/water separators on the fuel filters. Siphon water from the fuel tank and clean the tank if necessary
	Plugged air filter	Clean and replace if necessary
	Plugged fuel filter	Replace the fuel filter
	Engine problems	Turn the compressor OFF. See the Engine Warning/Shutdown Table for probable causes
	Starter solenoid relay does not engage	Check wiring and tighten all connectors Replace relay
	No input frequency from alternator	Check alternator "W" terminal (7.5 ± 2.50 VAC greater than 300 HZ)
SSAM FLASH CODE: FIVE FLASHES	No fuel	Check fuel level and fill tank if empty
	Defective fuel switch	Replace switch

Table 5-1: Troubleshooting

ENGINE STOPS, DOES NOT CRANK OR CRANKS BUT DOES NOT START		
SYMPTOM	PROBABLE CAUSE	REMEDY
Compressor does not achieve full discharge pressure	Run/start switch not in run position	For compressors with idle warm-up controls, switch toggle to RUN for full operation
	Air demand is excessive	Check service lines for leaks or open valves
	Dirty air filter	Check the filter and change the element if required
	Defective pressure regulator	Check the diaphragm and replace with kit if necessary
	Defective idle warm-up control	Replace control
Improper unloading with an excessive pressure build-up causing the pressure relief valve to open	Pressure regulating valve is set too high	Readjust
	Control system leak causing loss of pressure signal	Check control lines
		Defective pressure regulating valve. Repair valve (kit available)
	Inlet valve jammed	Free or replace valve
	Restriction in the control system	Check all control lines and components. Ice and/or other contaminants could be the cause
	Defective pressure relief valve opens when pressure is too low	Replace the pressure relief valve
Defective pressure regulator	Check the diaphragm and replace with kit if necessary	
Insufficient air delivery	Run/start switch not in run position	For compressors with idle warm-up controls, switch toggle to RUN for full operation
	Plugged air filter	Replace
	Defective idle warm-up control	Replace control
	Plugged air/fluid separator	Replace separator element and also change compressor fluid and fluid filter
	Defective pressure regulator	Adjust or repair
	Engine speed too low	Readjust engine speed
Excessive compressor fluid consumption	Clogged return line	Clear orifice and return line strainer
	Lubrication system leak	"Check all pipes, connections and components"
	Separator element damaged or malfunctioning	Change separator element

Section 6

NOISE CONTROL

6.1 NOISE EMISSIONS WARRANTY

Sullair Corporation warrants to the ultimate purchaser and each subsequent purchaser that this air compressor was designed, built and equipped to conform at the time of sale to the first retail purchaser, with all applicable noise control regulations.

This warranty is not limited to any particular part, component, or system of the air compressor. Defects in the design, assembly, or in any part, component, or system of the compressor which, at the time of sale to the first retail purchaser, caused noise emissions to exceed Federal standards are covered by this warranty for the life of the air compressor.

6.2 TAMPERING WITH THE NOISE CONTROL SYSTEM IS PROHIBITED

U.S. Law prohibits the following acts or the causing thereof:

1. The removal or rendering inoperative by any persons, other than for purposes of maintenance, repair, or replacement, of any device or element of design incorporated into any new compressor for the purpose of noise

control prior to its sale or delivery to the ultimate purchaser or while it is in use.

2. The use of the compressor after such device or element of design has been removed or rendered inoperative by any person.

Among those acts included in the prohibition against tampering are the acts listed below:

1. Removal or rendering inoperative any of the following:
 - a. Engine exhaust system or parts thereof
 - b. Compressor air intake system or part thereof
 - c. Enclosure of part thereof
2. Removal of any of the following:
 - a. Vibration isolators
 - b. Control silencer
 - c. Floor panel
 - d. Fan shroud
 - e. Acoustical materials including fiberglass foam or foam tape
3. Operation with canopy doors open for any purpose other than starting, stopping, adjustment, repair, replacement of parts or maintenance.

6.3 NOISE EMISSIONS MAINTENANCE AND MAINTENANCE RECORD LOG

The following instructions and maintenance record log book, for the proper maintenance, use and repair of this compressor, is intended to prevent noise emission degradation.

NOISE EMISSION MAINTENANCE AND MAINTENANCE RECORD LOG

1. ANNUAL MUFFLER AND EXHAUST SYSTEM INSPECTION
At least annually inspect muffler(s) and engine exhaust system to make sure all parts are securely mounted, that all joints and connections are tight, and that the muffler is in good condition. DO NOT operate compressor with defective exhaust system. Remove and replace any defective parts by ordering with part numbers indicated in the Parts List.
Maintenance Performed
By
Location
Date
Maintenance Performed
By
Location
Date
2. ANNUAL AIR FILTER(S) AND AIR INLET SYSTEM INSPECTION
In addition to the instructions in the Maintenance section of the Operator’s Manual, the air filter(s) and entire air inlet system should be inspected at least annually, to make sure all parts are securely mounted, that all joints and connections are tight, that there are no other leaks in the system, and that the filter element(s) are intact. DO NOT operate compressor with defective air inlet system. Remove and replace defective parts by ordering with part numbers indicated in the Parts List.
Maintenance Performed
By
Location
Date
Maintenance Performed
By
Location
Date

3. ANNUAL ENGINE VIBRATION MOUNT INSPECTION
At least annually inspect engine vibration mounts for security of attachment and to make sure the resilient parts are intact. DO NOT operate compressor with defective engine mounting system. Remove and replace defective parts by ordering with part numbers indicated in Parts List.
Maintenance Performed
By
Location
Date
Maintenance Performed
By
Location
Date
4. ANNUAL FRAME, CANOPY, AND PARTS INSPECTION
At least annually inspect frame, canopy and parts, for security of attachment. Make sure there are not any missing or deformed members, including all hinged doors, covers and their fastening devices. DO NOT operate compressor with defective frame, canopy and parts. Remove and replace defective parts by ordering with part numbers indicated in Parts List.
Maintenance Performed
By
Location
Date
Maintenance Performed
By
Location
Date
5. ANNUAL ACOUSTICAL MATERIALS INSPECTION
At least annually inspect all acoustical materials, if any, for security of attachment. Make sure that there is not any material missing or damaged (refer to Parts List). Clean or replace, if necessary. DO NOT operate compressor with defective acoustical material. Remove and replace defective parts by ordering with part numbers indicated in the Parts List.
Maintenance Performed
By
Location
Date
Maintenance Performed
By
Location
Date

6. ANNUAL INSPECTIONS FOR PROPER OPERATION OF ALL SYSTEMS.
In addition to other instructions in the Operator's Manual, at least annually, operate compressor and inspect to make sure all systems are operating properly and that engine runs at rated speed and pressure. DO NOT operate malfunctioning or improperly adjusted compressor. Repair or adjust, per instructions in Operator's Manual, as required.
Maintenance Performed
By
Location
Date
Maintenance Performed
By
Location
Date



WORLDWIDE SALES AND SERVICE

SULLAIR ASIA, LTD.

Sullair Road, No. 1
Chiwan, Shekuo
Shenzen, Gunagdong PRV.
PRC POST CODE 518068
Telephone: 755-6851686
Fax: 755-6853473
www.sullair-asia.com

SULLAIR CORPORATION

3700 East Michigan Boulevard
Michigan City, Indiana, 46360 U.S.A.
www.sullair.com
Telephone: 1-800-SULLAIR (U.S.A. only)
Fax: 219-874-1273

CUSTOMER CARE for PARTS and Service

1-888-SULLAIR (7855247)
219-874-1835

SULLAIR EUROPE, S.A.

Zone Des Granges BP 82
42602 Montbrison, France
Telephone: 33-477968470
Fax: 33-477968499
www.sullaireurope.com

Champion Compressors, LTD.

Princess Highway
Hallam, Victoria 3803
Australia
Telephone: 61-3-9796-4000
Fax: 61-3-9703-8053
www.championcompressors.com.au

Printed in the U.S.A.

Specifications subject to
change without prior notice.
E08EP