

Mastiff 200

SAFETY & OPERATORS MANUAL

& PARTS LISTING

CAUTION: Read the instruction manual before using the appliance.



Mastiff 200

Table of Contents

Specifications	2
Drum Setups	2
Safety instructions	3
Safety instructions	4
Operating instructions	5
Operating instructions	7
Electrical safety	8
Parts Listing - Main Chassis - Petrol	9
Parts Listing - Main Chassis - 1 Phase	10
Parts Listing - Main Chassis - 3 Phase	11
Parts Listing - Inner Chassis - Petrol	12
Parts Listing - Inner Chassis - Petrol List	13
Parts Listing - Inner Chassis - 1 Phase	14
Parts Listing - Inner Chassis - 1 Phase List	15
Parts Listing - Inner Chassis - 3 Phase	16
Parts Listing - Inner Chassis - 3 Phase List	17
Parts Listing - Bearings & Shaft	18
Parts Listing - Lifting Mechanism	19
Parts Listing - Drum and Cutters	20
Wiring Diagram 1 Phase	21
Wiring Diagram 3 Phase	22
Maintenance Schedule	23

Mastiff 200 Specifications

Mastiff 200	
Weight	138kg
Dimensions	1000 x 617 x 1037 (Length X Width x Height)
Rated Voltage	9Hp Petrol / 230 Vac / 415 Vac
Rated Watts	NA / 2.2kW / 4kw / 5.5kw
Preparation Path	200mm

Drum Setups

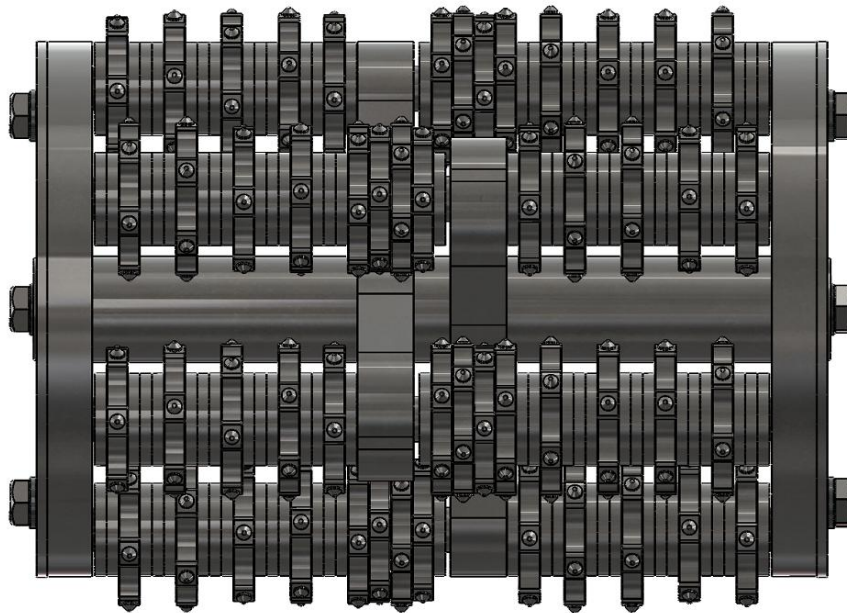

Typical Drum Setups		
Setup	Cutters	Spacers
General Purpose	78 Cutters	171
Fine	96	142

Mastiff 200

Safety instructions

1. Read and understand the instructions on the machine and in this manual and engine manual (if applicable). Different models may have different parts and controls.
2. Equipment should only be operated by trained personnel, in good physical condition and mental health (not fatigued). The operator and maintenance personnel must physically be able to handle the bulk weight and power of this machine.
3. This is a **one person machine**. Maintain a safe operating distance to other personnel. Remember 'one machine, one operator'.
4. This equipment is intended for commercial use.
5. For the operators' safety and the safety of others, always keep all guards and shrouds in place.
6. Never start or run machine when unattended.
7. This machine is intended for use on floor surfaces only.
8. Never start or run machine with handle folded or when disk(s) are not in contact with the surface.
9. Do not lend or rent machine without the operating instructions for the machine (and the engine, if applicable).
10. Wear clothing suitable for the job and for the workplace including, safety shoes, hard hat, hearing protection, non-fogging vented safety goggles, and dust mask suitable for dust.
11. Keep body parts or any loose clothing away from moving parts. Failure to comply could result in bodily injury.

Mastiff 200

Safety instructions

12. Do not modify machine in any way. Only use genuine MASTIFF 200 parts and accessories.
13. Repairs should be performed by qualified persons only.
14. Ensure parts have stopped moving and disconnect power or spark plug when servicing or changing blades or accessories.
15. Never operate machine in rain or if heavy moisture is present. (other than under the shroud)
16. Do not operate MASTIFF 200 with any guards, shrouds, covers or doors removed or open.
17. The MASTIFF 200 can produce sound pressure levels greater than 85db. The operator must wear approved safety ear protection.
18. Do not allow the supply cord to come in contact with the cutting blade/head or other moving parts of this machine.
19. Petrol is extremely flammable and poisonous. Petrol should only be dispensed in well ventilated areas, and only when engine is cool.
20. **WARNING! POISONOUS EXHAUST GASES.** Do not operate petrol powered equipment without adequate ventilation. Carbon monoxide is an invisible odorless gas that can harm or can kill you.
21. **WARNING!** Breathable silica may be generated by use and maintenance of this machine. Silica can cause severe and permanent lung damage, cancer, and other serious diseases. Do not breathe the dust. Do not rely on your sight or smell to determine if dust is in the air. Silica may be in the air without a visible dust cloud. If air monitoring for silica is not provided by your employer at your work site, you must wear appropriate respiratory protection when operating or maintaining this equipment. Consult your employer for proper respiratory protection.

Mastiff 200

Operating instructions

1. Wear clothes suitable for the job and for the work place including, safety shoes, hard hat, hearing protection, non-fogging vented safety goggles, and dust respirator suitable for dust.
2. **WARNING! POISONOUS EXHAUST GASES.** Do not operate petrol powered equipment without adequate ventilation. Carbon monoxide is an invisible odorless gas that can harm or can kill you.
3. Be sure all equipment is tested and tagged prior to use on any job.
4. Inspect entire area to be ground before grinding and remove any bolts or concrete nails (etc.) that could damage diamond tooling or machine which could cause a hazardous situation.
5. Ensure there are no obstacles or existing structures that could present a hazard to the operator. If so, take necessary action to eliminate the hazard.
6. Install appropriate tooling into the machine. Only use genuine MASTIFF 200 tooling. Failure to comply could result in bodily injury.
7. Stand in front of the machine, put one foot on the front nudge bar and use the lift hook to tilt the machine over onto its front.

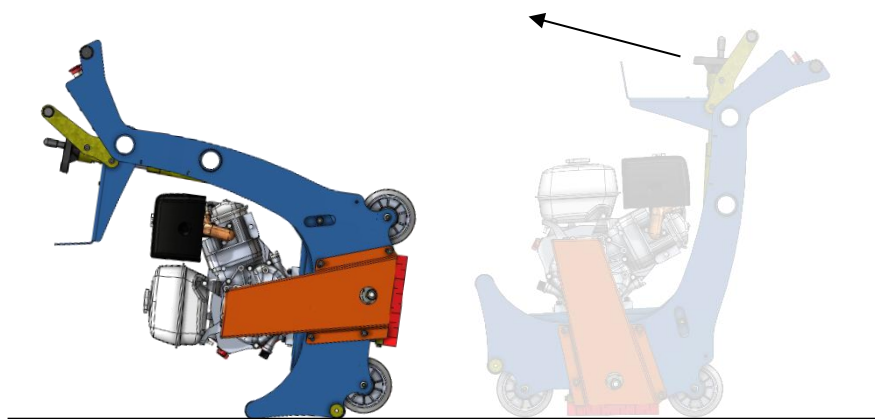

- 8.
9. Inspect and install appropriate tooling and tighten using the left hand nuts. One at a time.

Mastiff 200

Operating instructions

10. Tilt machine back onto its wheel in the opposite manner to above.
11. Wind the height adjustment knob fully clockwise and pull the fast raise lower lever towards you.
12. Connect machine to suitable power outlet. Only use heavy duty power lead suitable for high current use (minimum 2.5 mm² cable), no longer than 20 meters. (For petrol powered equipment, refer to engine manual for startup procedure).
13. If no power is available within the specified distance, have a qualified person install a suitable power outlet closer to your work. Alternatively use 4mm² cable for up to 50 meters.
14. Connect a suitable dust extractor to the machine via a 50mm flexible hose. The machine is designed to take the standard FLOOREX 50mm hose ends to make connection of dust extractors easy and hassle free. Alternatively, water spray using the supplied water connection point can be used to suppress dust.
15. Keep machine clear of drainage pits and grates or any such hazard. Failure to comply could result in bodily injury and or could damage the machine or property.
16. Switch on the dust extractor or water spray.
17. Hold the handles firmly and switch the machine on by pushing the green button. Or start the petrol engine.
18. If the over-current device trips it indicates a problem. (Undersize power lead or poor power to GPO outlet). Refer above for recommendations on power leads. Rectify problem or decrease load on grinder by using tooling with more surface area. **Continuing to use the MASTIFF 200 when constant tripping occurs, VOIDS THE WARRANTY!**

Mastiff 200

Operating instructions

19. This machine is designed to operate with the wheels in contact with the floor at all times. **Do not operate with wheels off the floor.**
20. Push the fast raise lower lever forward then wind the depth control anti clockwise to lower to tools onto the floor.
21. Once the tools start touching the floor you can rotate the hand wheel a total of 4 more turns for maximum cut depth.
22. This equates to a maximum cutting depth of around 3-4mm. Lowering the machine further will risk damaging the drum and fails and shafts.

Mastiff 200

Electrical safety

1. All electrical maintenance and repairs to be carried out by qualified persons only.
2. **CAUTION** - Line terminals may be alive when main switch is in the off position. Disconnect all power at source before performing any maintenance or repairs.
3. **WARNING - DO NOT** operate the machine with any electrical panels open.
4. **WARNING** - The MASTIFF 200 has an overload switch and will trip when under excessive load and will not allow the machine to be switched on if it is overloaded. (Overload will need to be reset when safe to do so). **Continuing to use the MASTIFF 200 when constant tripping occurs, VOIDS THE WARRANTY!**
5. Never operate machine in the rain or if heavy moisture is present.
6. The overcurrent device is there to protect you and the machine from harm. **DO NOT** alter or adjust the overload in any way. If it is faulty, only replace with original part that is identical to the faulty one.
7. Never bypass over-current devices in this machine.
8. Never connect or disconnect power cables with voltage present or while under load.
9. Disconnect all power connections and observe lock out / tag out procedures before attempting to carry out any maintenance or repair on any equipment.
10. Avoid any contact with any rotating parts or driven parts.
11. Never use equipment that has not been tested and tagged (including cords).
12. Do not operate MASTIFF 200 with any covers or doors removed or open.
13. Before connecting the machine to power, check the condition of all power leads and cables on, or used in conjunction with the machine. **DO NOT USE** it if any fault(s) cuts; wear marks, Bare wires out of plugs or sockets, etc. Get qualified persons to repair and re-tag it as required by regulations in your country.

Mastiff 200

Parts Listing - Main Chassis - Petrol

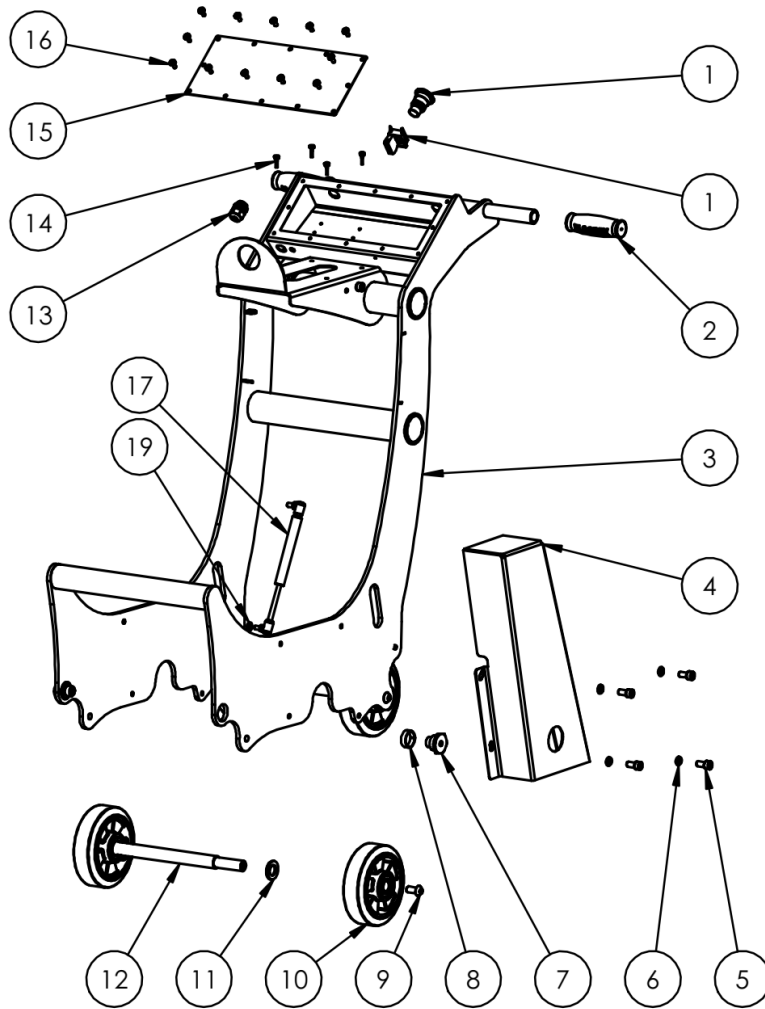

ITEM NO.	PartNo	DESCRIPTION	
1	G3-031	Emergency Stop Switch Complete	1
2	G3-350	Floorex Hand Grip	2
3	MAF-010	Mastiff 200 Main Outer Chassis	1
4	MAF-015	Mastiff 200 Main Belt Guard	1
5	FS-245	M10 X 20 Socket Head Cap Screw	6
6	FS-317	M10 Spring Washer	6
7	MET-342	Meteor Chassis Pivot Nut	2
8	MET-341	Meteor 250 Generation3 Pivot Bush	2
9	FS-222	12 X 25 Button Head	4
10	MET-016	Wheel 160mm Grey Rubber 20mm ID	4
11	FS-335	M20 Standard Washer	4
12	MAF-050	Mastiff Front and Rear Axle	2
13	G3-036	Cable Gland M20	1
14	MAF-120	Rubber Bumper Stop	4
15	MAF-020	Mastiff 200 Control Box Lid	1
16	FS-565	Screw Pan Head M6 X 12 Phillips	12
17	MAF-070	Mastiff 200 Gas Strut	2
18	FS-345	M10 Standard Nut	2
19	FS-331	M8 Standard Washer	2

Mastiff 200

Parts Listing - Main Chassis - 1 Phase

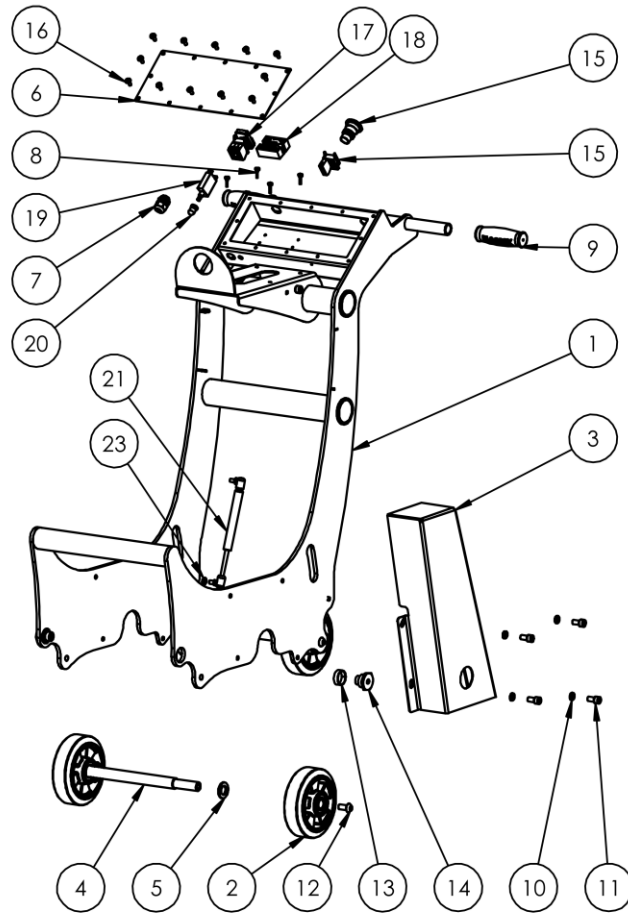

ITEM NO.	PartNo	DESCRIPTION	QTY.
1	MAF-010	Mastiff 200 Main Outer Chassis	1
2	MET-016	Wheel 160mm Grey Rubber 20mm ID	4
3	MAF-015	Mastiff 200 Main Belt Guard	1
4	MAF-050	Mastiff Front and Rear Axle	2
5	FS-335	M20 Standard Washer	4
6	MAF-020	Mastiff 200 Control Box Lid	1
7	G3-036	Cable Gland M20	1
8	MAF-120	Rubber Bumper Stop	4
9	G3-350	Floorex Hand Grip	2
10	FS-317	M10 Spring Washer	6
11	FS-245	M10 X 20 Socket Head Cap Screw	6
12	FS-222	12 X 25 Button Head	4
13	MET-341	Meteor 250 Generation3 Pivot Bush	2
14	MET-342	Meteor Chassis Pivot Nut	2
15	G3-031	Emergency Stop Switch Complete	1
16	FS-565	Screw Pan Head M6 X 12 Phillips	12
17	G3-030	Start Stop Switch Complete	1
18	G3-653	SSR with Internal 3 Wire control	1
19	MET-003	Overload 13A	1
20	G3-049	Overload Boot	1
21	MAF-070	Mastiff 200 Gas Strut	2
22	FS-345	M10 Standard Nut	2
23	FS-331	M8 Standard Washer	2

Mastiff 200

Parts Listing - Main Chassis - 3 Phase

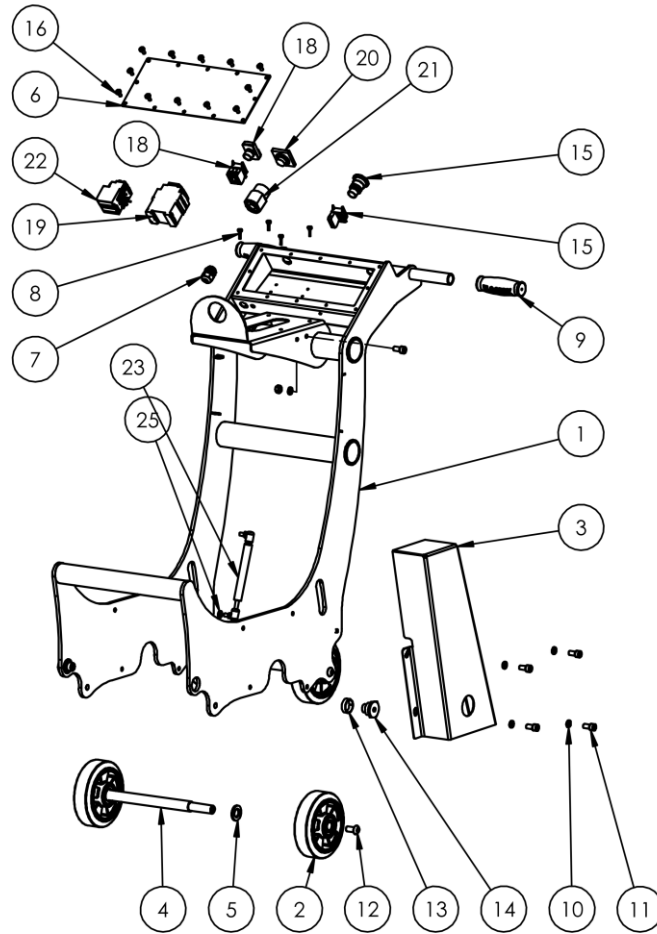

ITEM NO.	PartNo	DESCRIPTION	QTY.
1	MAF-010	Mastiff 200 Main Outer Chassis	1
2	MET-016	Wheel 160mm Grey Rubber 20mm ID	4
3	MAF-015	Mastiff 200 Main Belt Guard	1
4	MAF-050	Mastiff Front and Rear Axle	2
5	FS-335	M20 Standard Washer	4
6	MAF-020	Mastiff 200 Control Box Lid	1
7	G3-036	Cable Gland M20	1
8	MAF-120	Rubber Bumper Stop	4
9	G3-350	Floorex Hand Grip	2
10	FS-317	M10 Spring Washer	6
11	FS-245	M10 X 20 Socket Head Cap Screw	6
12	FS-222	12 X 25 Button Head	4
13	MET-341	Meteor 250 Generation3 Pivot Bush	2
14	MET-342	Meteor Chassis Pivot Nut	2
15	G3-031	Emergency Stop Switch Complete	1
16	FS-565	Screw Pan Head M6 X 12 Phillips	12
17	FS-553	M4 X 12 Screw Pan Head Phillips	2
18	G3-030	Start Stop Switch Complete	1
19	G3-386	Contactora 12A 415 VAC	1
20	G3-428	Reversing Switch Actuator	1
21	G3-427	Reversing Switch Mechanism only	1
22	G3-389	Overload 7-10A LRD14	1
23	MAF-070	Mastiff 200 Gas Strut	2
24	FS-345	M10 Standard Nut	2
25	FS-331	M8 Standard Washer	2

Mastiff 200

Parts Listing - Inner Chassis - Petrol

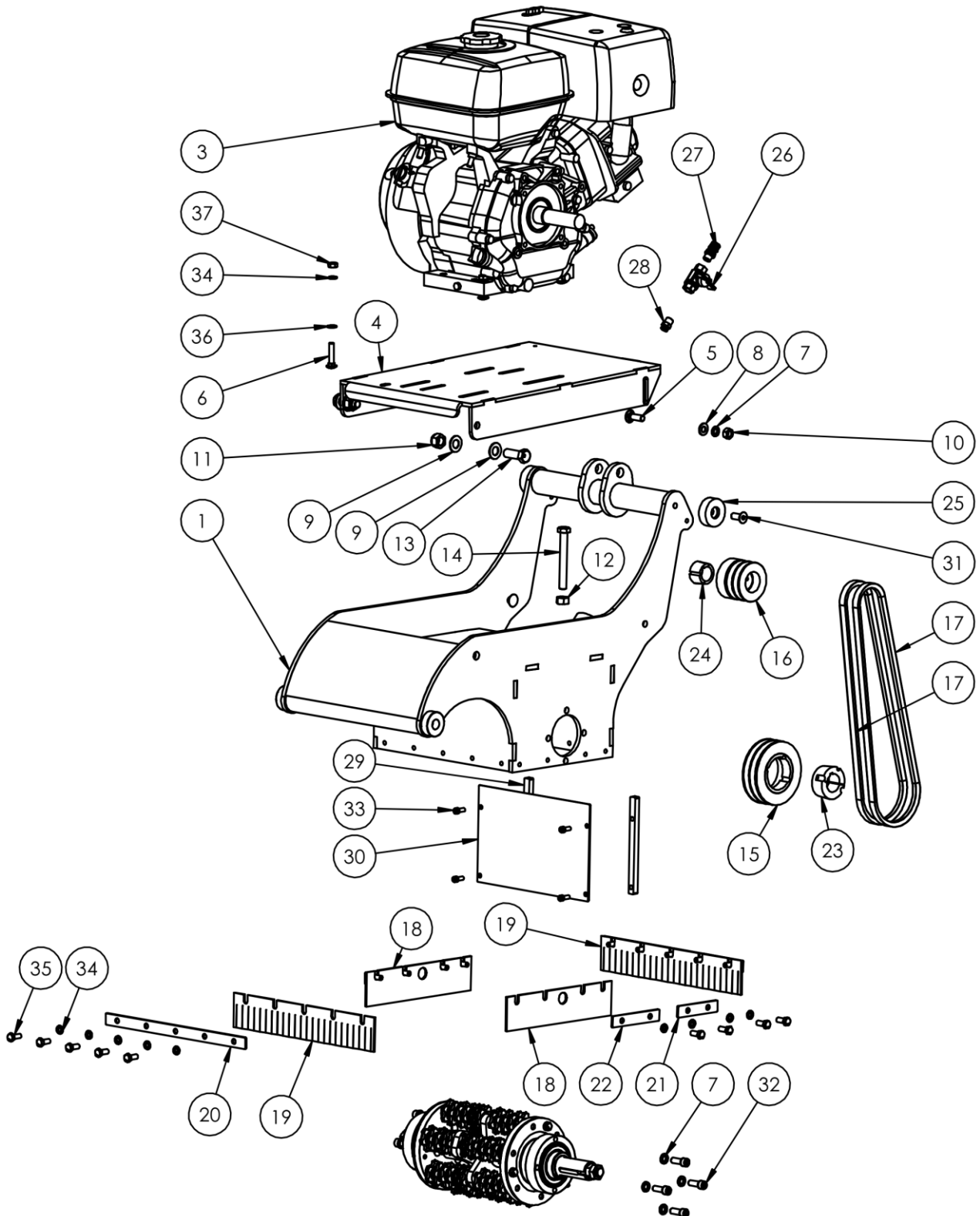

Mastiff 200

Parts Listing - Inner Chassis - Petrol List

ITEM NO.	PartNo	DESCRIPTION	
1	MAF-005	Mastiff 200 Inner Chassis	1
2		See Parts Lsting	1
3	G3-416	GX-270 Honda Standard Rope Start 1" Shaft	1
4	MAF-025	Mastiff 200 Motor Mount	1
5	FS-455	Cup Head Bolt M10 X 30	2
6	FS-453	Cup Head Bolt M8 X 40	4
7	FS-317	M10 Spring Washer	10
8	FS-332	M10 Standard Washer	2
9	FS-334	M14 Standard Washer	4
10	FS-345	M10 Standard Nut	2
11	FS-367	M14 Nyloc Nut	2
12	FS-346	M12 Standard Nut	1
13	FS-308	M14 X 40 Hex Head Set Screw	2
14	FS-301	M10 X 100 Hex Head Set Screw	1
15	MAF-111	Pulley 1610 106mm x 2A	1
16	MAF-126	Pulley 1108 63mm 2A	1
17	G3-506	AX 37 Belt	2
18	MAF-030	Mastiff 200 Skirt Side	2
19	MAF-032	Mastiff 200 Skirt Front And Back	2
20	MAF-035	Mastiff 200 Skirt Front And Back Retainer	2
21	MAF-039	Mastiff 200 Skirt Side Retainer 80mm Long	2
22	MAF-037	Mastiff 200 Skirt Side Retainer 100mm Long	2
23	MAF-110	Taper Lock Bush 1610 x 1-1/4" Bore	1
24	MAF-125	Taper Lock Bush 1108 x 1" Bore	1
25	MAF-063	Mastiff 200 - Chassis Guide Spacer	2
26	G3-153	Ball Valve 1/4 Butterfly	1
27	MET-063	Brass Tap adapter	1
28	G3-154	1/4" male X 6mm Push in Fitting for Nylon Tube	1
29	MAF-027	Mastiff 200 Vacuum Pickup Panel Set (3 Parts)	2
30	MAF-027	Mastiff 200 Vacuum Pickup Panel Set (3 Parts)	1
31	FS-268	M10 X 25 Socket Head Countersunk Screw	2
32	FS-447	Screw Socket 3/8" NF x 1" Zinc	8
33	FS-231	M6 X 16 Socket Head Cap Screw	4
34	FS-316	M8 Spring Washer	22
35	FS-279	M8 X 20 Hex Head Set Screw	18
36	FS-331	M8 Standard Washer	4
37	FS-344	M8 Standard Nut	4

Mastiff 200

Parts Listing - Inner Chassis - 1 Phase

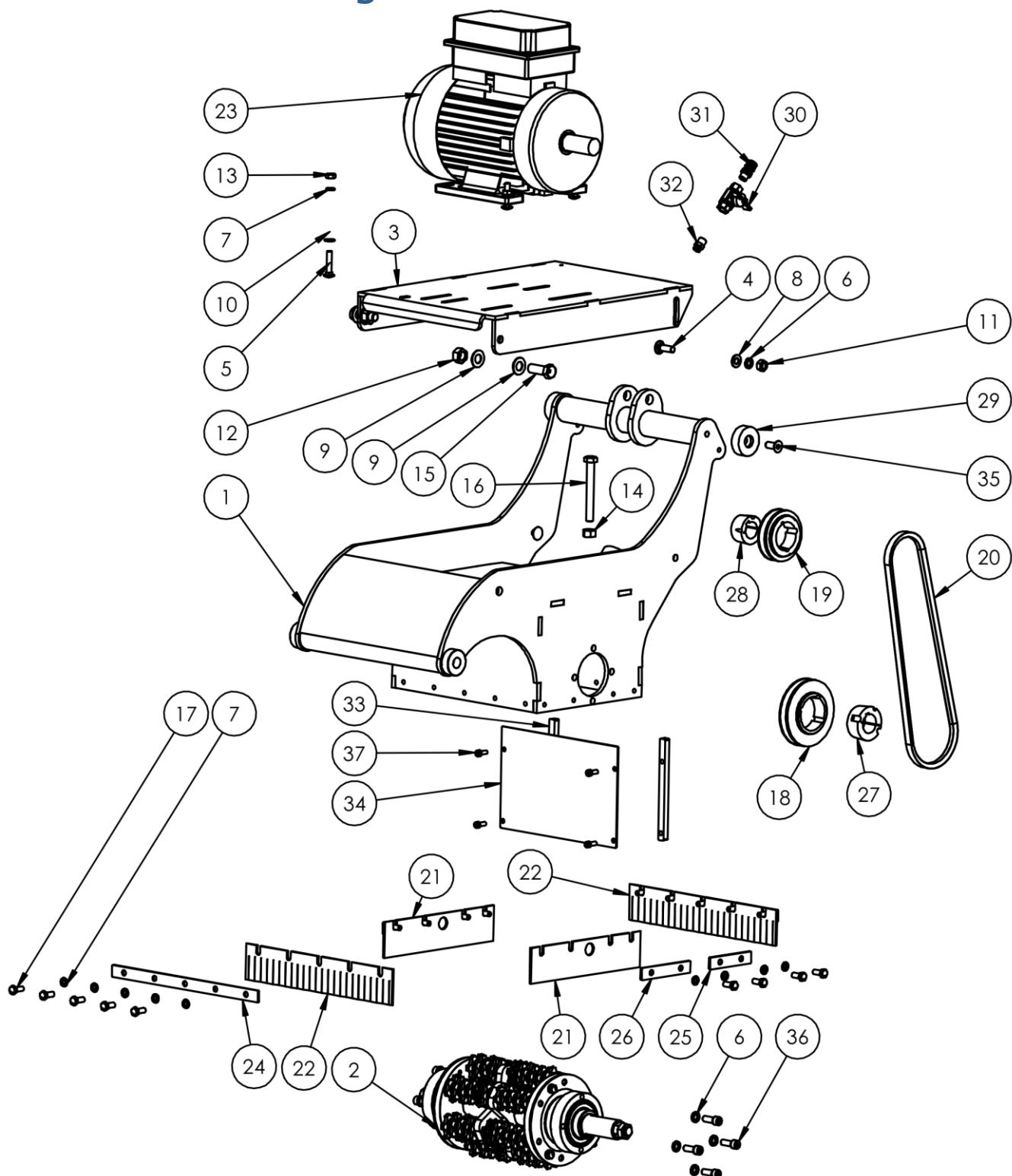

Mastiff 200

Parts Listing - Inner Chassis - 1 Phase List

ITEM NO.	PartNo	DESCRIPTION	
1	MAF-005	Mastiff200 Inner Chassis	1
2		See Parts Lsting	1
3	MAF-025	Mastiff200 Motor Mount	1
4	FS-455	Cup Head Bolt M10 X 30	2
5	FS-453	Cup Head Bolt M8 X 40	4
6	FS-317	M10 Spring Washer	10
7	FS-316	M8 Spring Washer	22
8	FS-332	M10 Engineers Washer	2
9	FS-334	M14 Engineers Washer	4
10	FS-331	M8 Engineers Washer	4
11	FS-345	M10 Standard Nut	2
12	FS-347	M14 Standard Nut	2
13	FS-344	M8 Standard Nut	4
14	FS-346	M12 Standard Nut	1
15	FS-308	M14 X 40 Hex Head Set Screw	2
16	FS-301	M10 X 100 Hex Head Set Screw	1
17	FS-279	M8 X 20 Hex Head Set Screw	18
18	MAF-113	Pulley 1610 106mm x 1A	1
19	MAF-117	Pulley 1210 80mm x 1A	1
20	G3-503	AX 35 Belt	1
21	MAF-030	Mastiff200 Skirt Side	2
22	MAF-032	Mastiff200 Skirt Front And Back	2
23	MET-032	Motor Ravel 4 Pole 2.2 Kw Complete	1
24	MAF-035	Mastiff200 Skirt Front And Back Retainer	2
25	MAF-039	Mastiff200 Skirt Side Retainer 80mm Long	2
26	MAF-037	Mastiff200 Skirt Side Retainer 100mm Long	2
27	MAF-110	Taper Lock Bush 1610 x 1-1/4" Bore	1
28	MAF-118	Taper Lock Bush 1210 x 28mm Bore	1
29	MAF-063	Mastiff200 - Chassis Guide Spacer	2
30	G3-153	Ball Valve 1/4 Butterfly	1
31	MET-063	Brass Tap adapter	1
32	G3-154	1/4" male X 6mm Push in Fitting for Nylon Tube	1
33	MAF-027	Mastiff200 Vacuum Pickup Panel Set (3 Parts)	2
34	MAF-027	Mastiff200 Vacuum Pickup Panel Set (3 Parts)	1
35	FS-268	M10 X 25 Socket Head Countersunk Screw	2
36	FS-447	Screw Socket 3/8" NF x 1" Zinc	8
37	FS-231	M6 X 16 Socket Head Cap Screw	4

Mastiff 200

Parts Listing - Inner Chassis - 3 Phase

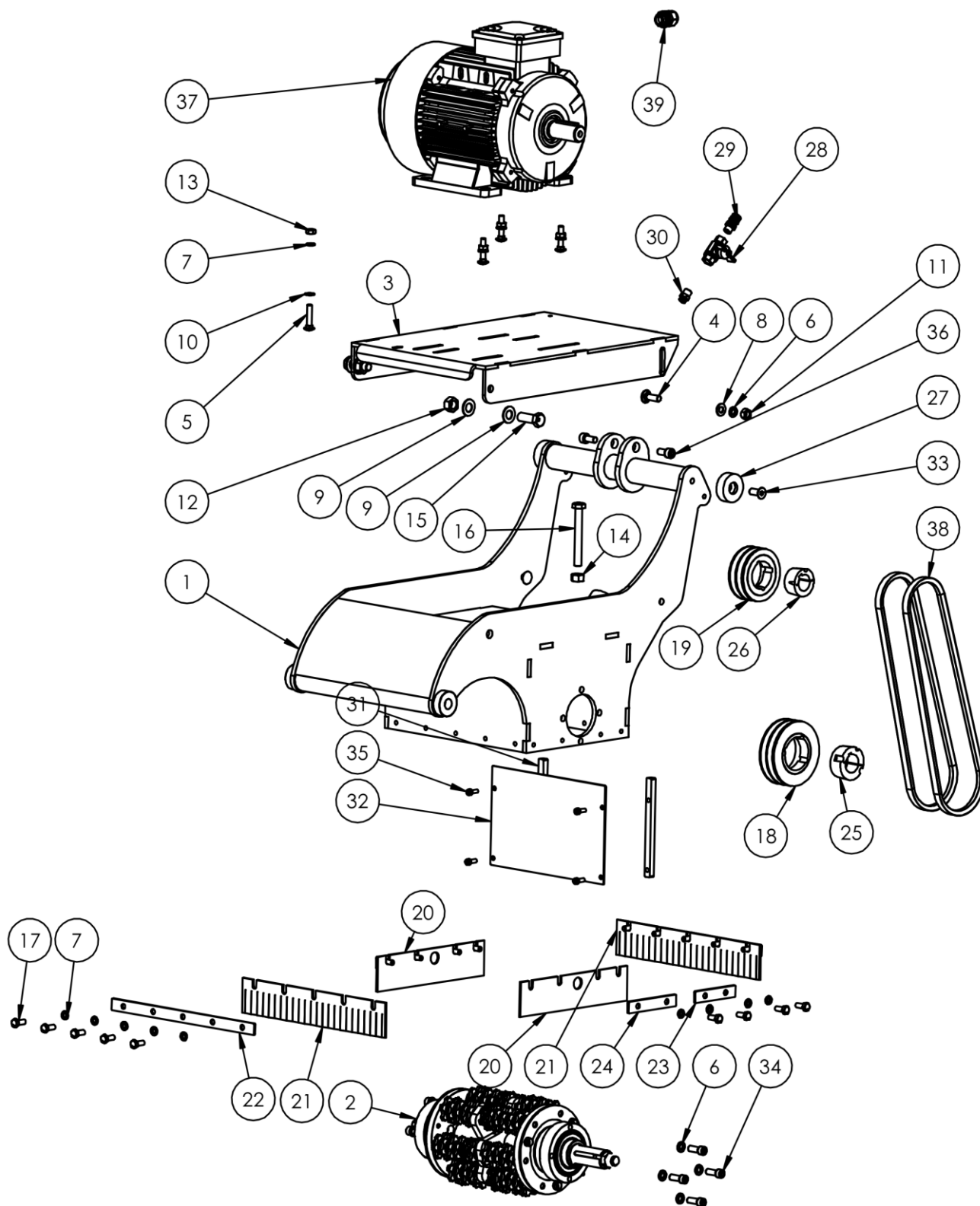

Mastiff 200

Parts Listing - Inner Chassis - 3 Phase List

ITEM NO.	PartNo	DESCRIPTION	QTY.
1	MAF-005	Mastiff 200 Inner Chassis	1
2		See Parts Listing	1
3	MAF-025	Mastiff 200 Motor Mount	1
4	FS-455	Cup Head Bolt M10 X 30	2
5	FS-453	Cup Head Bolt M8 X 40	4
6	FS-317	M10 Spring Washer	10
7	FS-316	M8 Spring Washer	22
8	FS-332	M10 Standard Washer	2
9	FS-334	M14 Standard Washer	4
10	FS-331	M8 Standard Washer	4
11	FS-345	M10 Standard Nut	2
12	FS-347	M14 Standard Nut	2
13	FS-344	M8 Standard Nut	4
14	FS-346	M12 Standard Nut	1
15	FS-308	M14 X 40 Hex Head Set Screw	2
16	FS-301	M10 X 100 Hex Head Set Screw	1
17	FS-279	M8 X 20 Hex Head Set Screw	18
18	MAF-111	Pulley 1610 106mm x 2A	1
19	MAF-119	Pulley 1210 85mm x 2A (For HD model)	1
20	MAF-030	Mastiff 200 Skirt Side	2
21	MAF-032	Mastiff 200 Skirt Front And Back	2
22	MAF-035	Mastiff 200 Skirt Front And Back Retainer	2
23	MAF-039	Mastiff 200 Skirt Side Retainer 80mm Long	2
24	MAF-037	Mastiff 200 Skirt Side Retainer 100mm Long	2
25	MAF-110	Taper Lock Bush 1610 x 1-1/4" Bore	1
26	MAF-118	Taper Lock Bush 1210 x 28mm Bore	1
27	MAF-063	Mastiff 200 - Chassis Guide Spacer	2
28	G3-153	Ball Valve 1/4 Butterfly	1
29	MET-063	Brass Tap adapter	1
30	G3-154	1/4" male X 6mm Push in Fitting for Nylon Tube	1
31	MAF-027	Mastiff 200 Vacuum Pickup Panel Set (3 Parts)	2
32	MAF-027	Mastiff 200 Vacuum Pickup Panel Set (3 Parts)	1
33	FS-268	M10 X 25 Socket Head Countersunk Screw	2
34	FS-447	Screw Socket 3/8" NF x 1" Zinc	8
35	FS-231	M6 X 16 Socket Head Cap Screw	4
36	FS-245	M10 X 20 Socket Head Cap Screw	2
37	G3-479	Motor 5.5 KW 2 Pole Foot Only 3 phase Aluminum (HD)	1
38	G3-506	AX37 (For HD Model)	2
39	G3-036	Cable Gland M20	1

Mastiff 200

Parts Listing - Bearings & Shaft

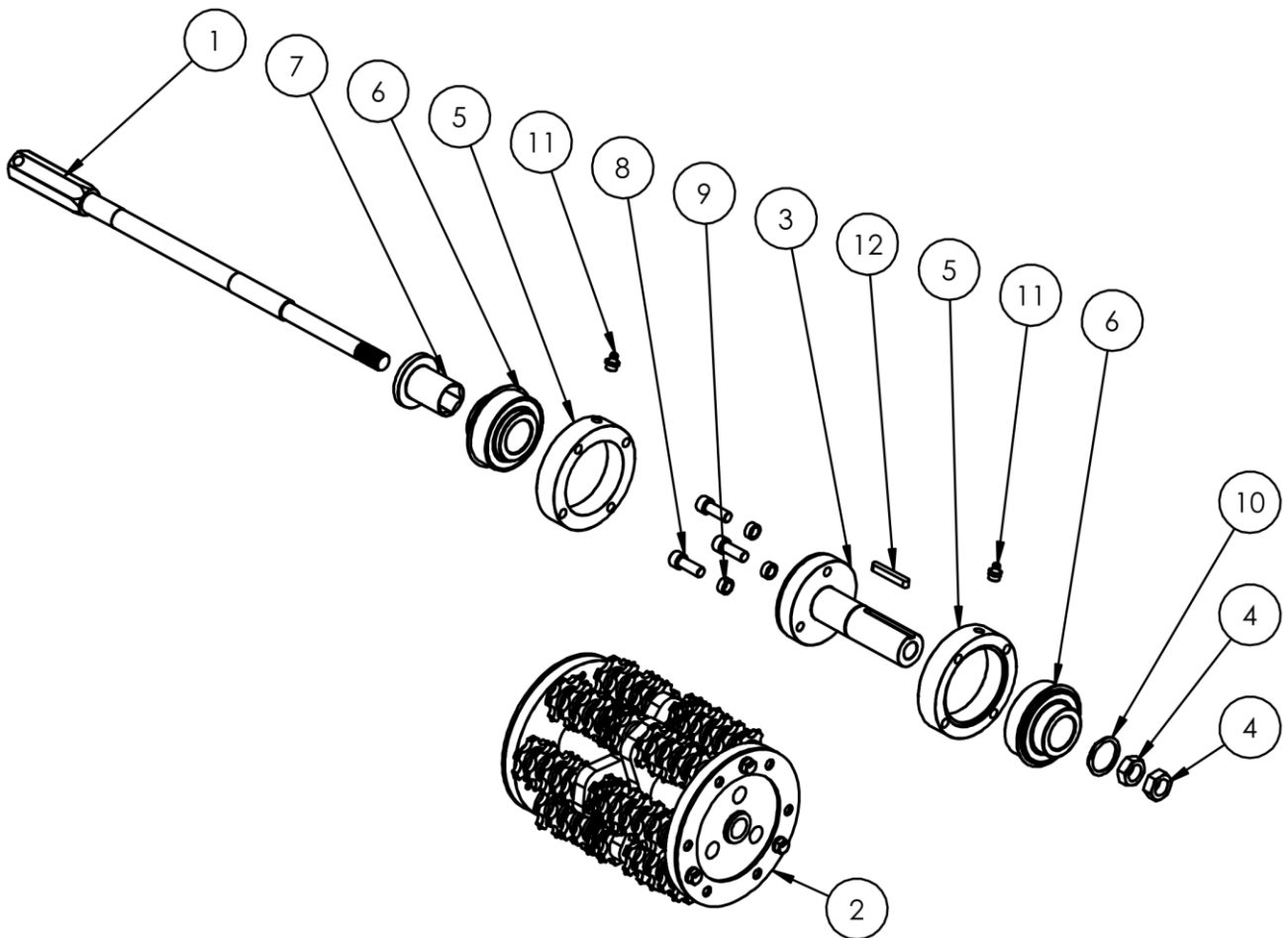

ITEM NO.	PartNo	DESCRIPTION	QTY.
1	MAF-108	Mastiff 200 Drum Shaft	1
2		See Parts Listing	1
3	MAF-106	Mastiff 200 Drum Driver	1
4	MAF-109	Meastiff Left Hand Nut	2
5	MAF-104	Mastiff 200 Bearing Housing	2
6	MAF-112	Mastiff Bearing 1-1/4 Bore	2
7	MAF-103	Bearing Hex Centre	1
8	FS-447	Screw Socket 3/8" NF x 1" Zinc	3
9	FS-448	NUT 3/8" NF Zinc (Remove Hex)	3
10	G3-826	Circlip External 1-1/4	1
11	G3-551	Grease Nipple 1/8 NPS	2
12	MAF-121	1/4 x 1 3/4 Key	1

Mastiff 200

Parts Listing - Lifting Mechanism

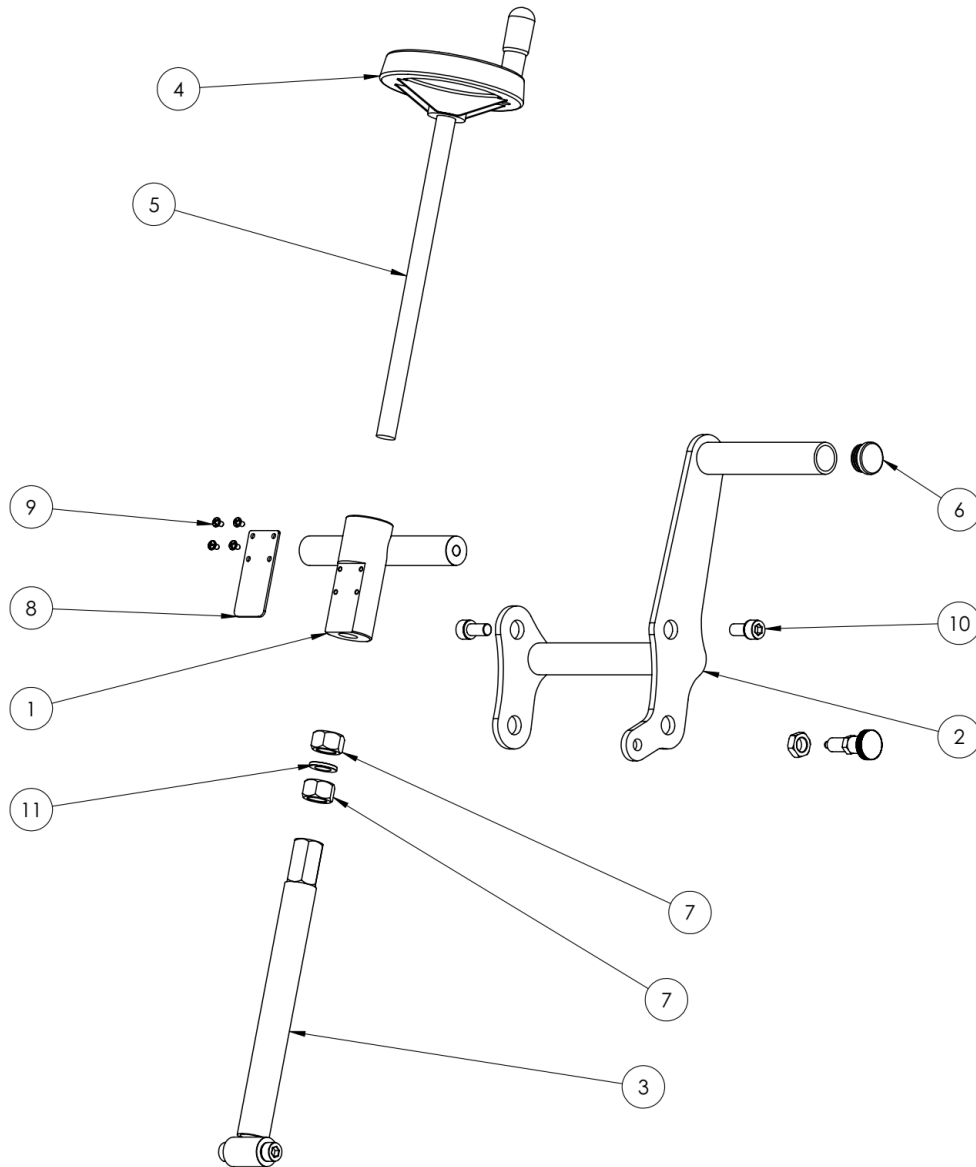

ITEM NO.	PartNo	Description	QTY.
1	MAF-049	Mastiff 200 - Depth Control Upper Section	1
2	MAF-060	Mastiff 200 - Depth Control Lever	1
3	MAF-055	Mastiff 200 - Depth Control Lower Section	1
4	MAF-048	Mastiff 200 - Depth Control Two Spoke Hand Wheel	1
5	N/A	Lift Lever Thread (included with above)	1
6	RP-076	Tube Cap 27OD	1
7	FS-368	M16 Standard Nut	2
8	MAF-124	Mastif 200 - Lift Lever Spring Steel Flap	1
9	FS-549	M4 X 6 Screw Pan Head Phillips	4
10	FS-245	M10 X 20 Socket Head Cap Screw	4
11	FS-319	M14 Spring Washer	1
12	G4-026	Index plunger for G4 swing weight	1
13	FS-3XX	M12 x 1.5 Half Nut	1

Mastiff 200

Parts Listing - Drum and Cutters

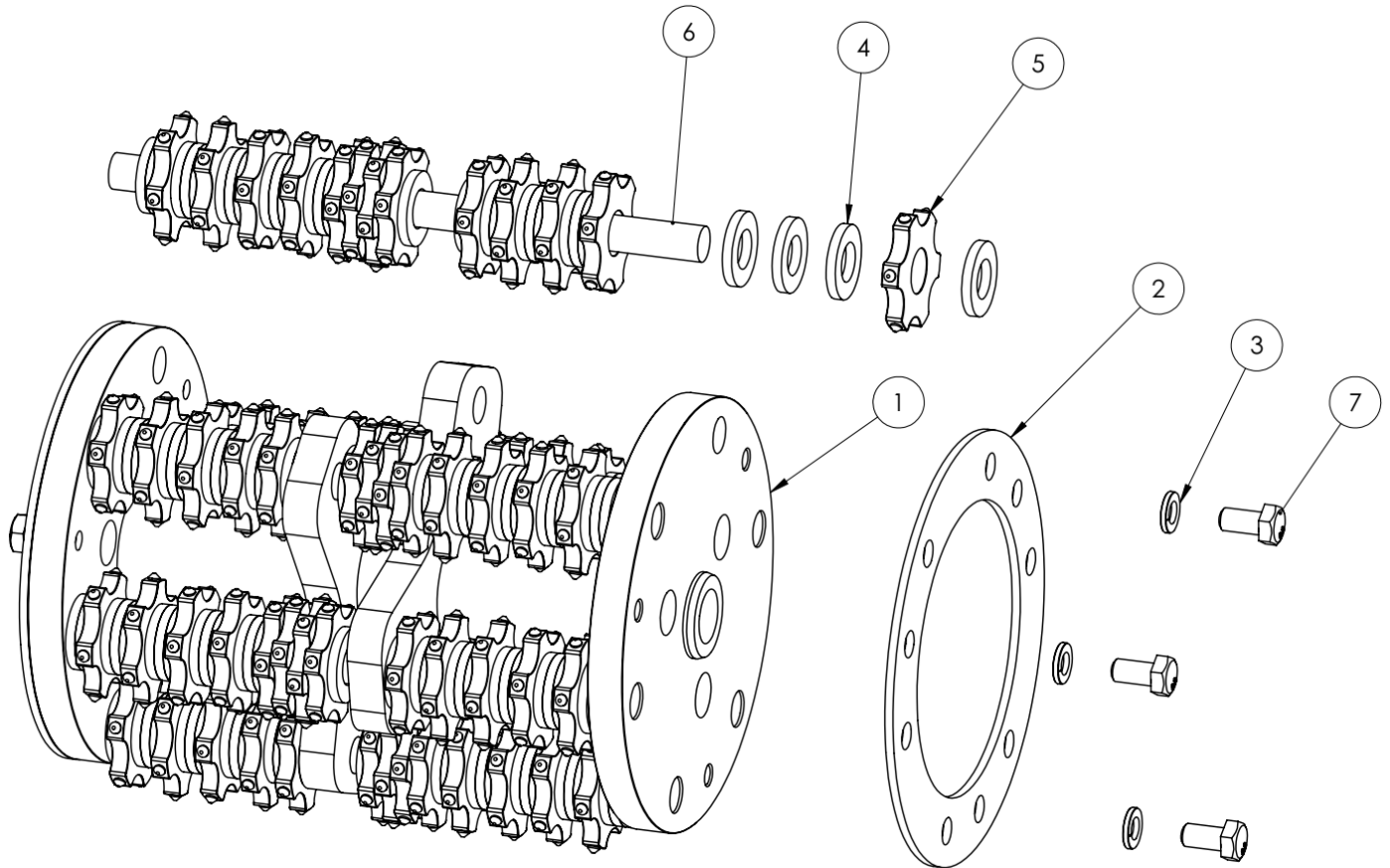

ITEM NO.	PartNo	DESCRIPTION	QTY.
1	MAF-160	Mastiff 200 Drum Bare	1
2	MAF-105	Mastiff Drum Shaft Retainer	2
3	FS-316	M8 Spring Washer	6
4	ED-12230	Hardened Spacer 1/2 inch	171
5	ED-20156	6 Point Cutter	78
6	ED-20150	Cutter Shaft	6
7	FS-278	M8 X 16 Hex Head Set Screw	6

Mastiff 200

Wiring Diagram 1 Phase

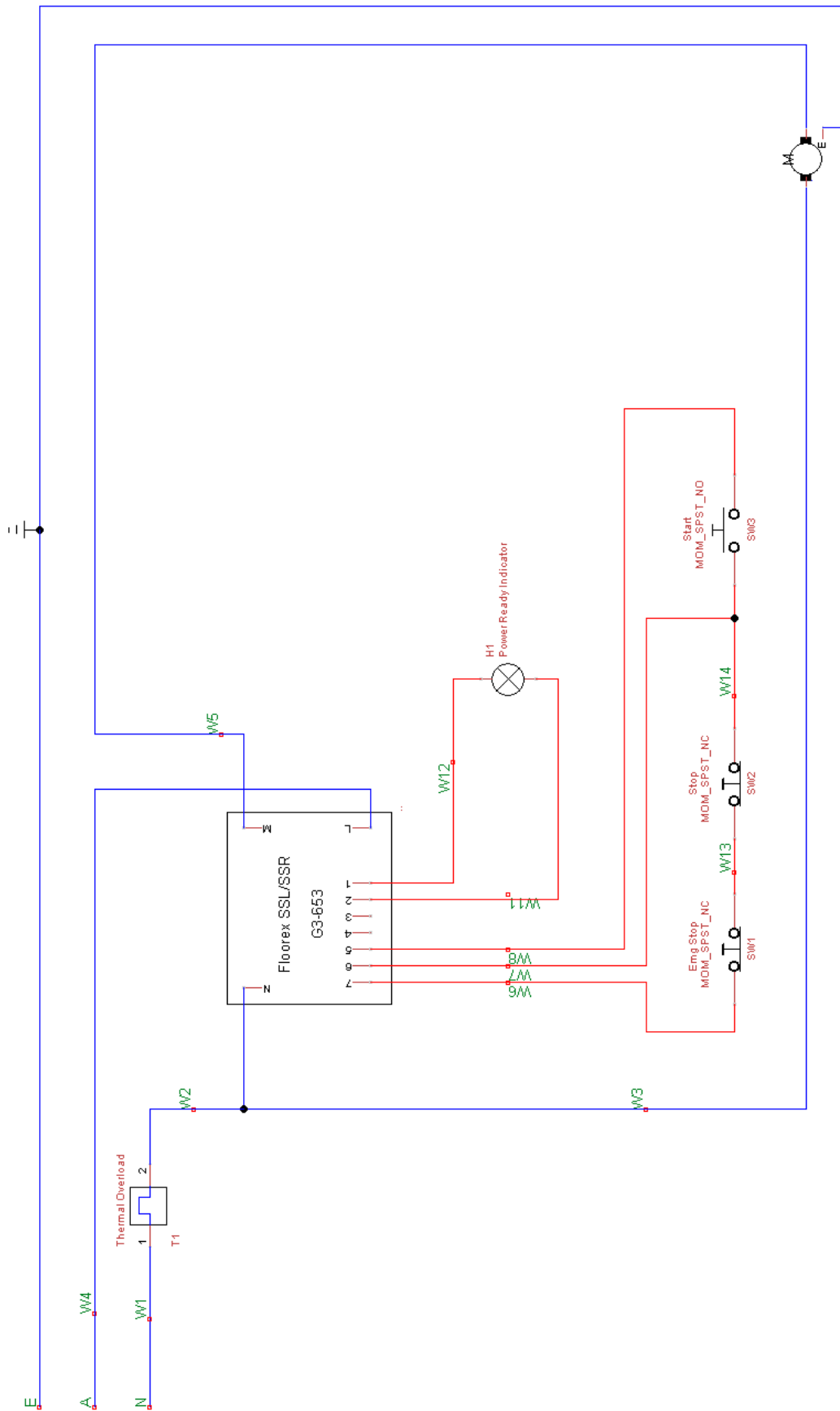

Mastiff 200

Wiring Diagram 3 Phase

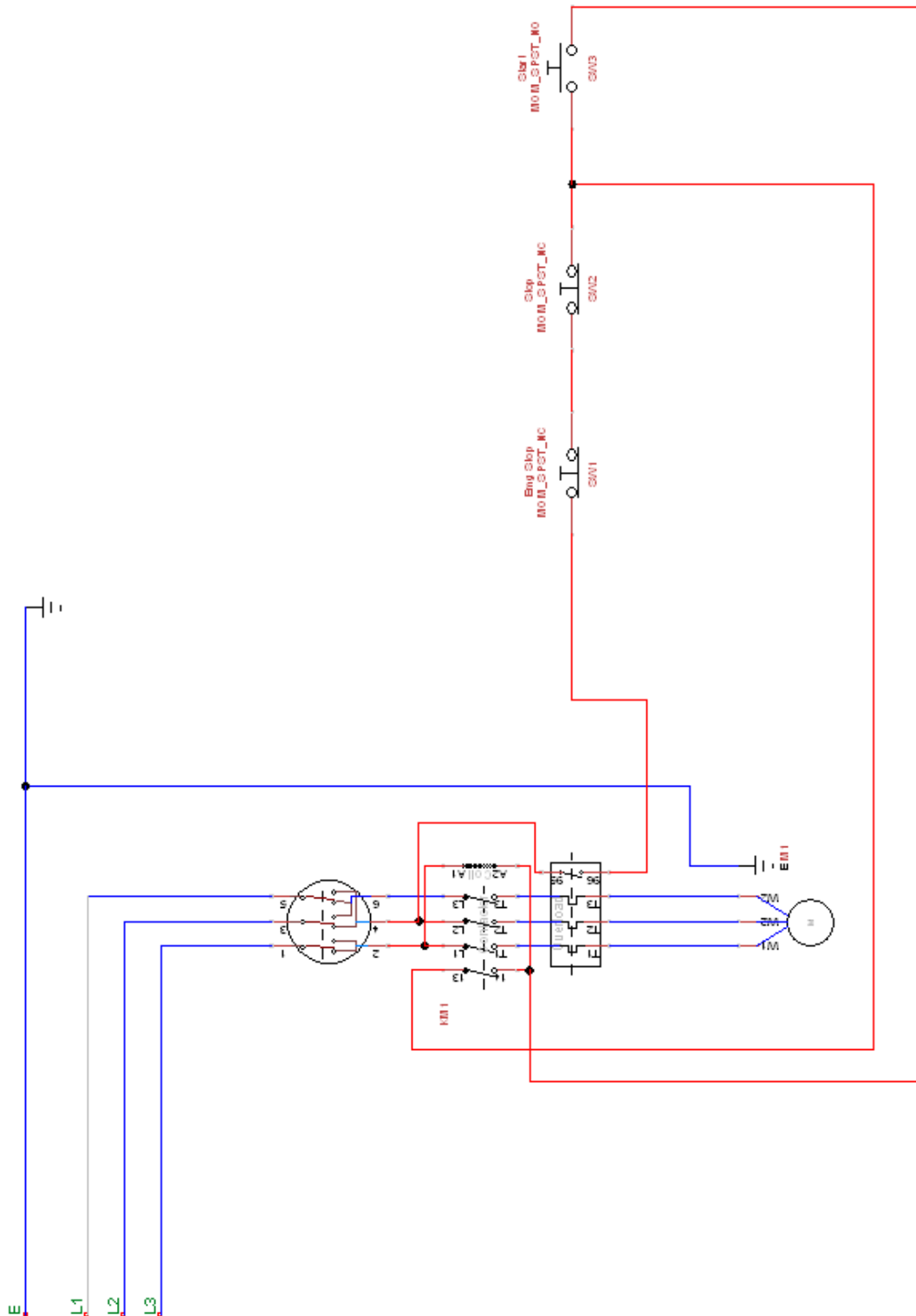

Mastiff 200

Maintenance Schedule

All Maintenance to be performed by qualified personnel.	Before Operation	Every 4 hours	Every 8 Hours	Daily or before Every Hire	Every 40-50 Hours of operation
Belt Tension					X
Check Engine Oil level	X				
Air Filter Element				X	
Change Engine Oil (Refer to Engine Manual)					X
Check main bearing units for play					X
Grease Bearings 2 Pumps		X			
Check Tooling condition		X			
Check Bearings			X		
Check Hex, Main shaft & Drive for wear					X

Mastiff 200

Mastiff 200

Mastiff 200



Floorex Products

Your complete supplier
of all your concrete
surface preparation
needs

- Diamond grinders
- Concrete Polishers
- Dust extraction
- Shotblasters
- Screed mixers
- Diamond Tooling
- Floor Scrapers
- Coating application

FLOOREX
PRODUCTS
11 Jennings Road
Swan Hill VIC.
3585

Web: www.floorex.com.au
Email: sales@floorex.com.au