

MC SERIES

MOTOR DRIVE MIGHTY CYLINDER MC SERIES

Reference table

● Mate machine			
Basic spec	1. Thrust power	Normal	(kg)、 Maximum (kg)
	2. Speed	mm/sec (50Hz、60Hz)	
	3. Stroke	Using Stroke	(mm)、 Maximum Stroke (mm)
Motor	4. Kind	Others	Safety device for overload With, Without
	5. Power		Outer LS Unit With (point), Without
Three phase 200V, 400V, 50Hz, 60Hz 220V, 440V, 380V, 460V Single phase 100V, 50Hz, 60Hz			Built-in Cam-type limit switches With (point), Without
Duration of use	6. Frequency	Installation method, other conditions	
	7. Time Cycle	Reciprocation/Min. Starting time/Min.	
	8. Operation time	h/day	h/year
Surroundings	9. Ambient temperature	℃	
	10. Dust	No Yes	
	11. Installation place	Indoor, Outdoor, Anti explosion	

(table 13)

Other linear actuators

- FAB series Friend Cylinder Perfect Synchronizing Air Cylinder
- FHB series Friend Cylinder Perfect Synchronizing Hydraulic Cylinder
- SC series Mighty Cylinder Perfect Synchronizing Motor driving Cylinder
- MD series Mighty Cylinder Electric Cylinder for Damper driving
- Worm Jack
- Ball Jack
- Bevel Jack

■ Specifications and dimensions may be changed without prior notice.
Please confirm in case of the planning.

'93-11

ユニテック工業(株) 営業部
 〒729-0105 広島県福山市南松永町3-5-45
 TEL.(084)933-4027 FAX.(084)933-4366
 Manufacturer  **Unitec Industry Co., Ltd.**
 3-85 Minamimatsunagacho Fukuyama City
 Hiroshima 729-01 Japan
 TEL. (0849) 33-4027 FAX. (0849) 33-4366

Agent

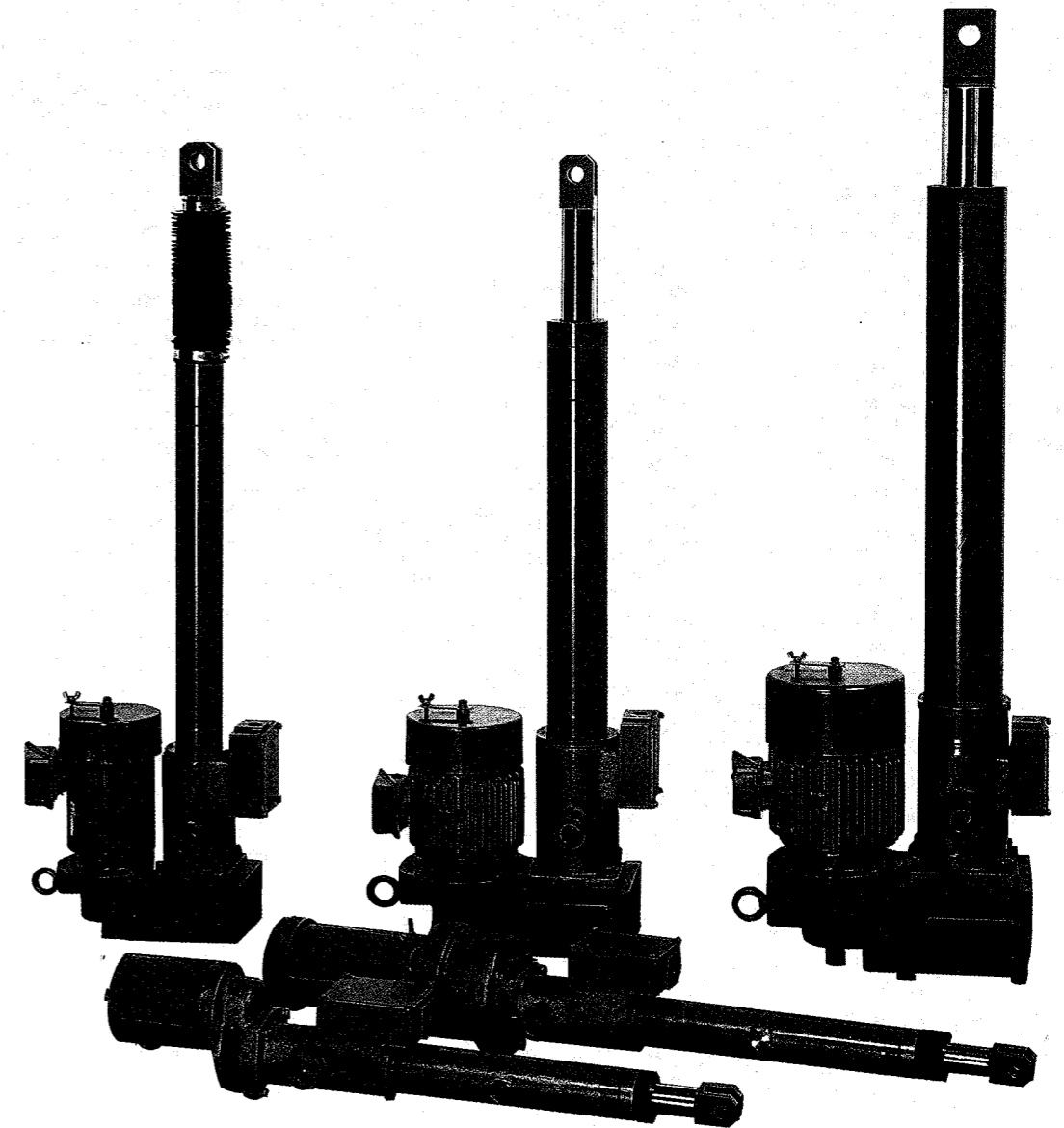

**UNITEC
INDUSTRY
CO., LTD.**

Simple & Compact !

Cost Down by Standardization !

A lot of Experience &

Business Records !!

Return Type
〈 MCL-Type 〉

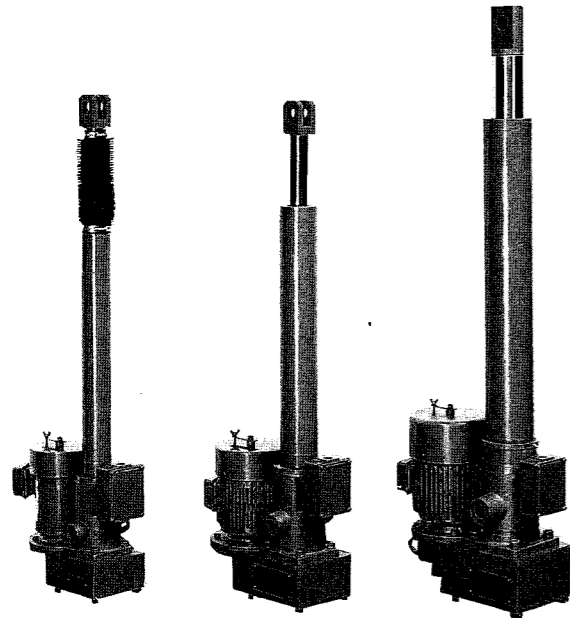

Straight Type
〈 MCSL-Type 〉

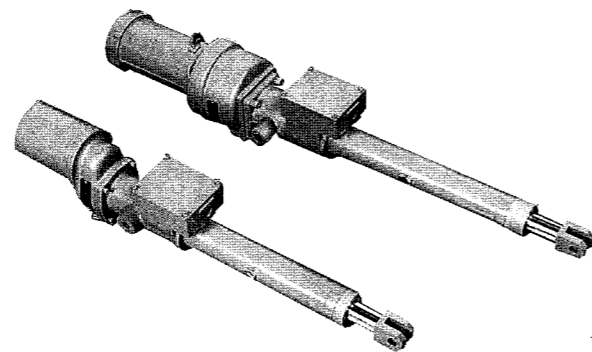

(Fig 1)

Strong Point

1. All types are equipped with Thrust Limiter with a built-in spring.
2. Power saving and stable movement are expected by use of high efficient screw nut and gears.
3. Lightening and Cost Down are realized by adoption of simple mechanism.
4. Clean and Maintenance free, for a long time due to the complete seal with grease lubrication.
5. High rigidity by use of the most suitable material parts in spite of compactness.

MC series Mighty Cylinder is a Linear Actuator which can be used by easy electrical wiring. We have standardized this series on the basis of our lots of experience and business records. Please select the type in accordance with the application, we are pleased to meet your requirement for special specifications.

List of standard type

Shape	Type	Thrust	Nominal Speed 50/60Hz (mm/sec)	Motor Capacity (kW)	Rod Rotational Torque (kg·m)	Screw Type	Standard Stroke (mm)	Brake spec.
Straight	MCSL B01 MCSL BB01	100kg	75/90	0.2	0.3	Trapezoidal Screw	200~700	without with (simultaneous cut off)
	MCSL B03 MCSL BB03	300kg	25/30	0.2	0.85	Trapezoidal Screw	200~700	without with (simultaneous cut off)
	MCSL C05 MCSL D1	500kg 1ton	25/30 25/30	0.4 0.75	1.4 2.7	Trapezoidal Screw Trapezoidal Screw	200~1000 200~1000	without without
	MCL B01	100kg	25/30	0.2	0.3	Trapezoidal Screw	200~700	with (simultaneous cut off)
Return	MCL B03	300kg	25/30	0.2	1.0	Trapezoidal Screw	200~700	with (simultaneous cut off)
	MCL B05 C05	500kg	22/26 45/54	0.2 0.4	2 2	Trapezoidal Screw Trapezoidal Screw	200~1000	with (simultaneous cut off)
	MCL B1 C1 D1	1ton	10/12 23/28 50/60	0.2 0.4 0.75	3.4 4 1.5	Trapezoidal Screw Trapezoidal Screw Ball Screw	200~1000	with (simultaneous cut off)
	MCL DT2 D2 E2	2ton	10/12 24/29 50/60	0.75 0.75 1.5	6.8 8 4	Trapezoidal Screw Trapezoidal Screw Ball Screw	200~1000	with (simultaneous cut off) (simultaneous cut off) (individual cut off)
	MCL D4 ET4 E4 F4 G4	4ton	12.5/15 10/12 25/30 35/42 60/72	0.75 1.5 1.5 2.2 3.7	8 12 8 8 8	Ball Screw Trapezoidal Screw Ball Screw Ball Screw Ball Screw	200~1500	with (simultaneous cut off) (simultaneous cut off) (simultaneous cut off) (individual cut off) (individual cut off)
	MCL E6 F6 G6	6ton	15/18 25/30 42/50	1.5 2.2 3.7	8 12 8	Ball Screw Ball Screw Ball Screw	200~1500	with (simultaneous cut off) (individual cut off) (individual cut off)
	MCL E8 F8 G8 H8	8ton	12.5/15 20/24 30/36 43/51	1.5 2.2 3.7 5.5	8 12 8 22	Ball Screw Ball Screw Ball Screw Ball Screw	200~1500	with (simultaneous cut off) (individual cut off) (individual cut off) (individual cut off)
	MCL F12 G12 H12	12ton	11/13 18.5/22 30/36	2.2 3.7 5.5	8 12 35	Ball Screw Ball Screw Ball Screw	200~2000	with (individual cut off)
	MCL F16 G16 H16 I16	16ton	8.3/10 15/18 20/24 30/36	2.2 3.7 5.5 7.5	8 12 65 8	Ball Screw Ball Screw Ball Screw Ball Screw	200~2000	with (individual cut off)
	MCL G32 H32 I32 J32	32ton	8/9.6 11/13.2 15/18 20/24	3.7 5.5 7.5 11	8 12 130 8	Ball Screw Ball Screw Ball Screw Ball Screw	200~2000	with (individual cut off)

*Speed is based on synchronous revolution of motor.

(table 1)

Construction & Material

- The construction of all types are completely sealed.
- Spur gears are used for reduction.
- Both trapezoidal screw and ball screw are adopted.
- Disk spring is built in the thrust limiter part.
Coil spring is used as far as the type with thrust power 100kg.
- Ductile cast iron is adopted for bracket.
- The material of gear box for two ton or less is normal cast iron and that of gear box for 4ton or more is ductile cast iron.
- The material of cylinder is STKM.
- The piston rod is made of stainless tube or hard chromium-plated STKM.

Example of application

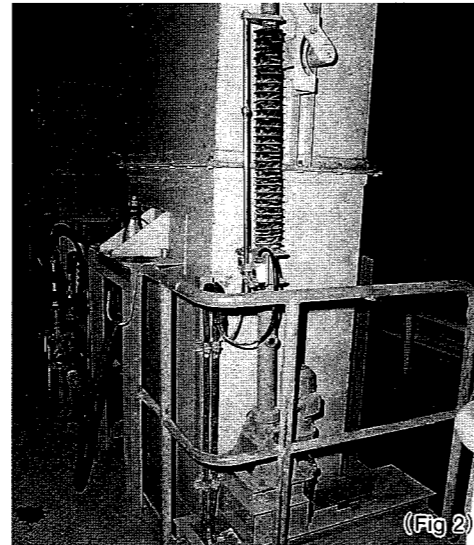

Construction

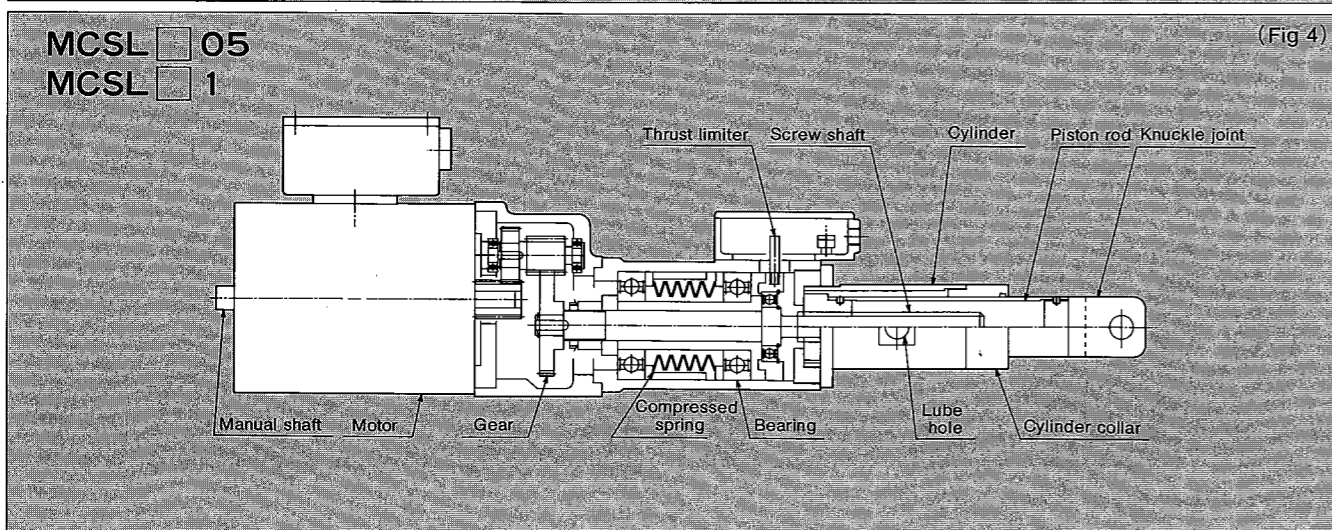
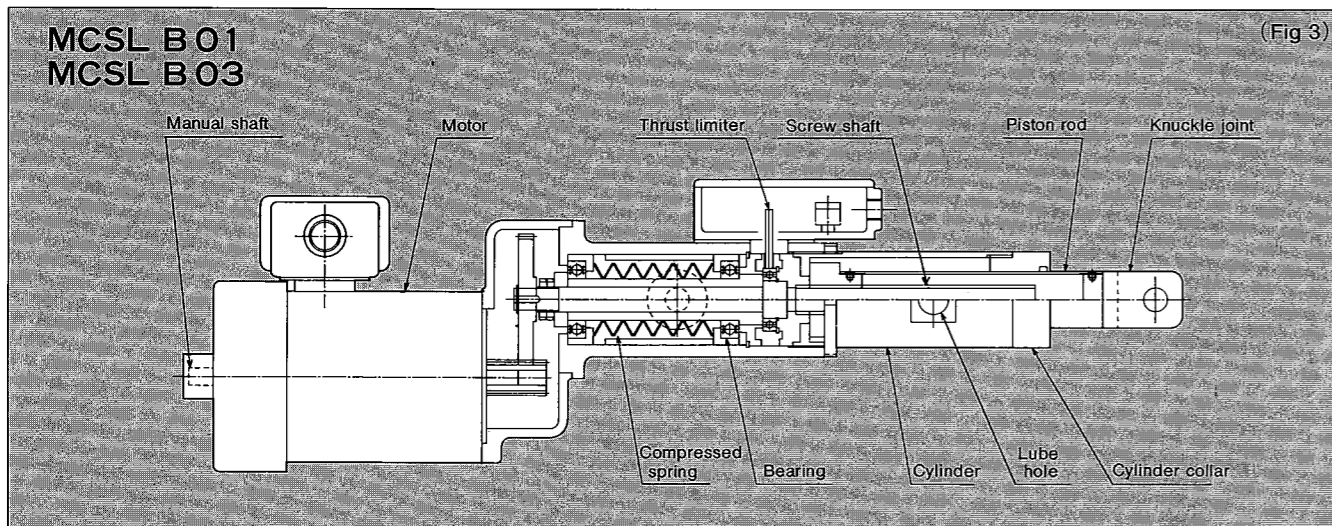

Example of application

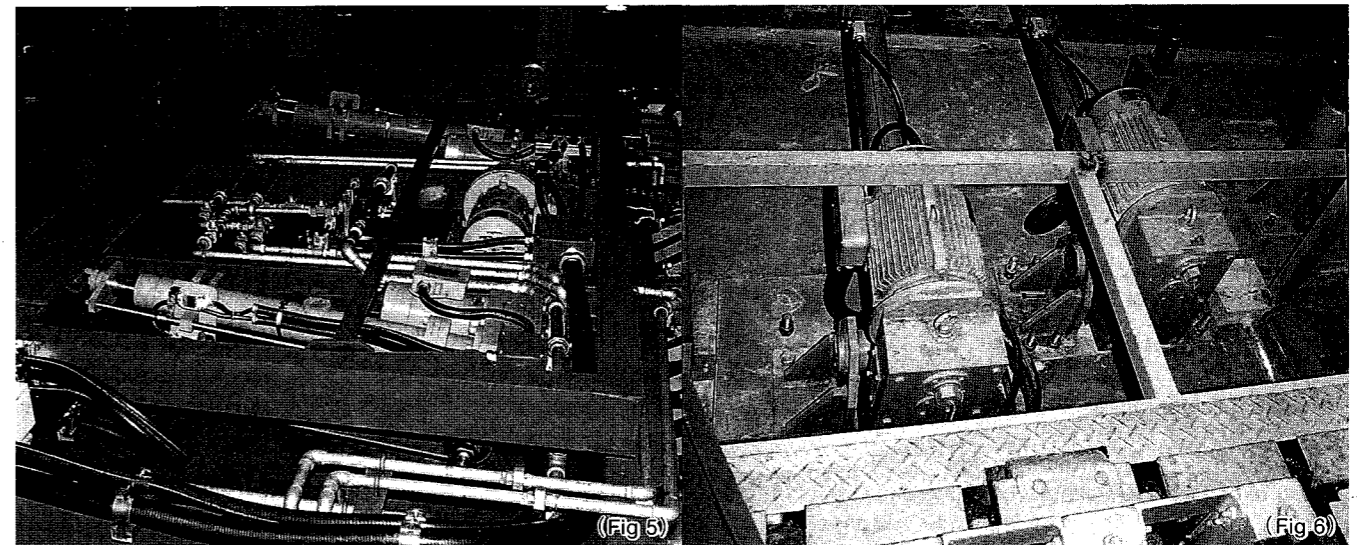

Construction

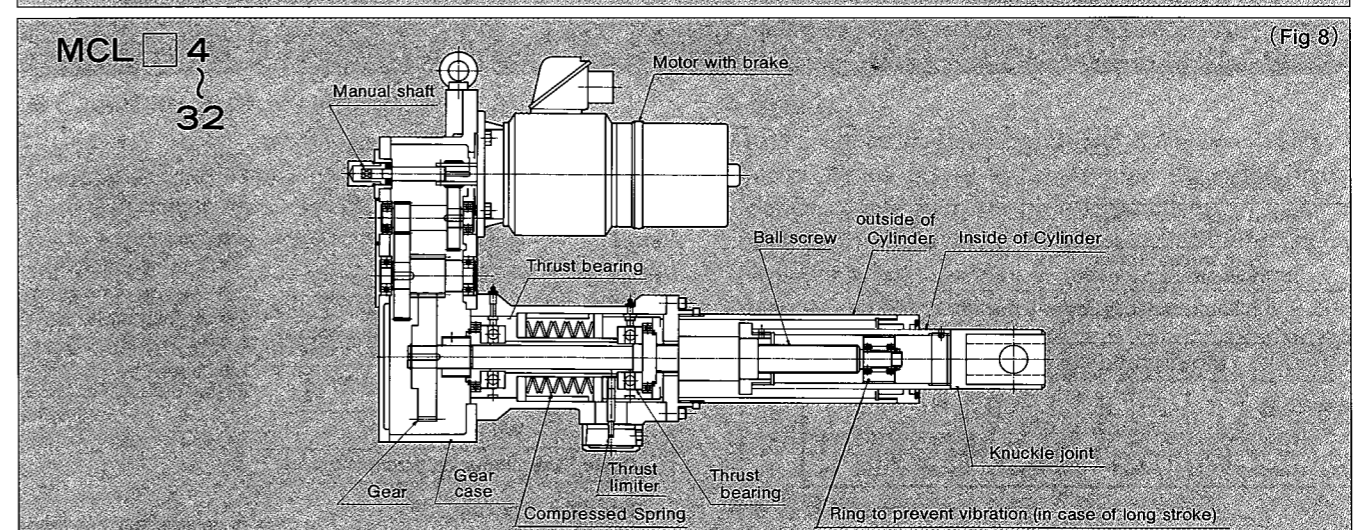
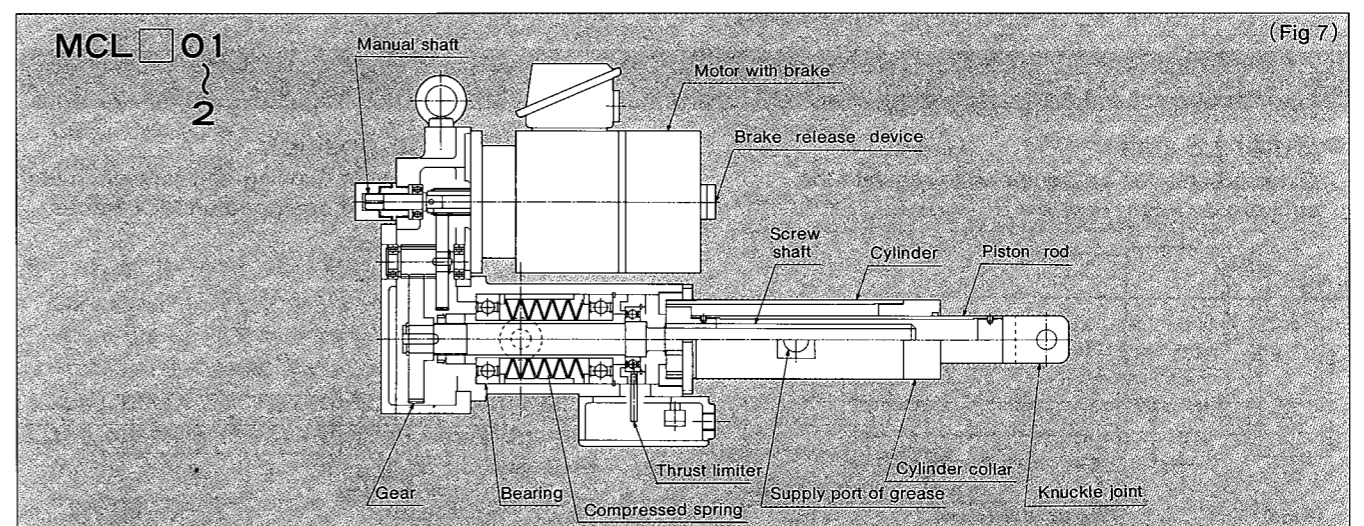

Standard type

Standard specifications

Construction	Totally enclosed outdoor type
Ambient temperature	-15°C ~ 50°C
Relative humidity	below 85%
Power Source	Three-phase 200V/220V or 400V/440V 50Hz/60Hz
Insulation	Class E
Rating	30 minutes

When water, steam, oil and so forth fall directly on the cylinder, equip the cover to protect them.

Painted color Munsell 7.5GY5/4.5

※ In case of dusty surroundings the type with bellows shall be recommended.
The material of bellows Neopren Heat proof 80°C

Special specifications

- Surroundings : The third anti-corruption painting is available in case of the surroundings likely to corrupt material.
- Ambient temperature : -40°C ~ 100°C is possible by using the grease for low or high temperature and changing the parts.
- Insulation : B · F · H can be met.
- Anti explosion : Available by using anti-explosion motor or limit switches.
The type with limit switches for overload detection is possible.
- Prevention of rotational torque :
Piston rod rotates in case of standard type. When the device to prevent the rotational torque of the piston rod can not be equipped on the mate machine, please let us know it.
- Heat proof for bellows : Heat proof 150°C or 300°C available.

Accessories' specifications

Outer LS unit

Outer LS unit can be equipped to regulate the stroke.

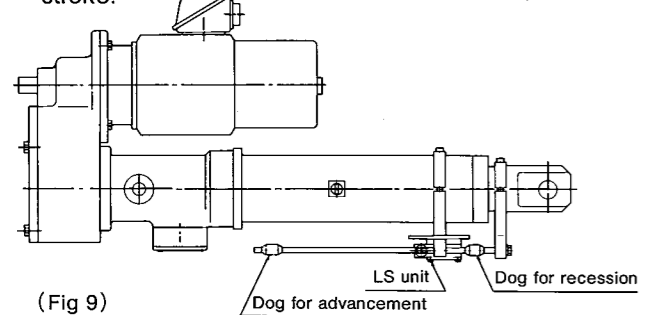

Unit to detect the position

Built-in limit switches for positioning and potentiometer for position indicator can be equipped on MCL series.

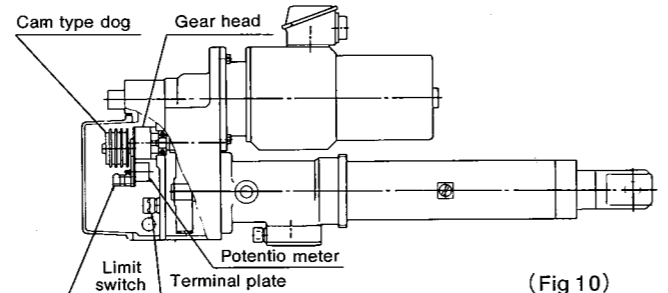

Expression of model number

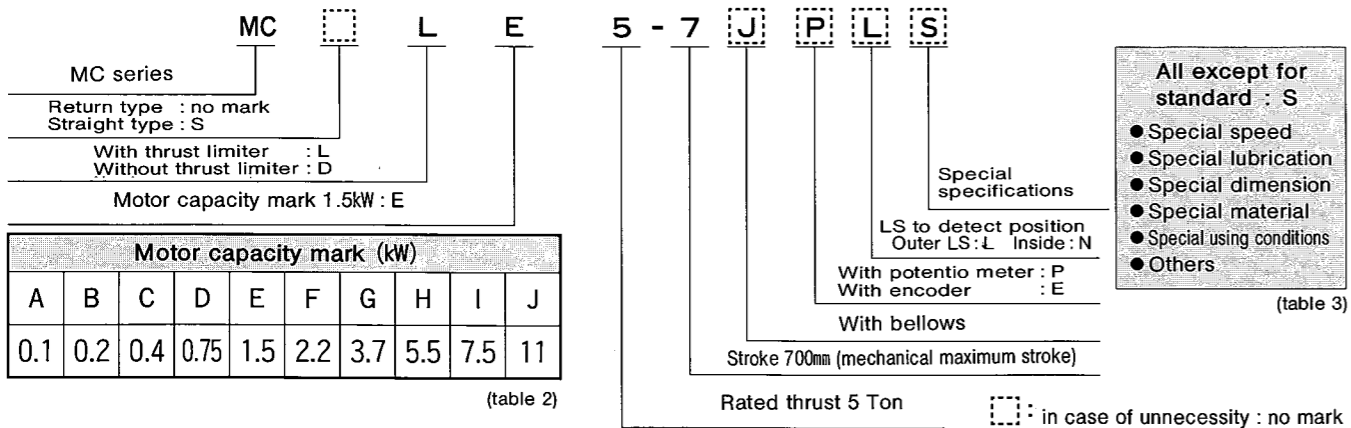

A	B	C	D	E	F	G	H	I	J
0.1	0.2	0.4	0.75	1.5	2.2	3.7	5.5	7.5	11

(table 2)

Selection

Selection shall be in accordance with the following procedures. Please refer to the Reference Table in the back cover on the conditions necessary for selection.

Selection procedures

- Calculate the thrust power needed.
In case of the movement of heavy objects, refer to the (formula 1) and the (table 4).
- Seek the using factor from the (table 5) taking the mate machine and the quality of the load into consideration.
- Seek the revised thrust power from thrust power and load. In case of synchronized operation, multiply synchronizing factor on the (table 6).
- Suitable type shall be selected from the list of standard type on the page 2 on the basis of revised thrust power, stroke, speed, power source and frequency. Refer to the (table 7) when the thrust power is 1 ton or less.

	(formula 1)	(table 4)
Pushing up & Suspension F = W + KW	F...Necessary thrust power W...Weight of objects	Speed mm/sec below 30 30~70 70~120
Horizontal movement F = MW + KW	M...Friction factor K...Accelerating factor	K 0.1 0.1~0.25 0.25~0.4

Nature of load	Factor
Smooth movement without shock	1.0
Movement with a little shock	1.25
Movement with big shock, vibration	1.5~2

Revised thrust power =

$$\frac{\text{Necessary thrust power} \times \text{Load factor} \times \text{Synchronizing factor}}{\text{Number of cylinders}}$$
 (formula 2)

Frequency

- Frequency shall be limited, because the Mighty Cylinder reciprocates by the use of reversible motor that has a certain heat capacity. Please note that starting times shall be less than those in (table 8). One reciprocation means 2 starting times.
- Duty factor 25%ED or less shall be kept. (formula 3)
- When the above conditions can not be met please consult us.

	(table 6)					
Number of cylinders	1	2	3	4	5	6
Synchronizing factor	1	1.25	1.4	1.65	1.8	2

Thrust power setted

- Spring built in the Mighty Cylinder is pre-compressed.
- When the LS of the thrust limiter actuates, that is 120% ~ 130% the rated thrust power, the spring is more compressed than the pre-compressed condition.
- The complete stop is made after a certain coasting after the signal, so the compressing power to the mate machine becomes more intense. In case of the use of the constant pressure stop, the strength of the mate device requires 250% or more the rated thrust power.

	(table 7)		
Straight type	Without brake or with brake	● Economical in case of simple movement ● Compact due to the straight shape	
Return type	All types are with brake	● Length is shorter than straight type ● All types for 2ton or more	

	(table 8)				
Mighty Cylinder type	● MCL series 0.8~0.4kW ● MCSL series 0.2kW	● MCL series 0.75~3.7kW	● MCL series 5.5kW, 7.5kW ● MCSL series 0.4kW, 0.75kW	● MCL series 11kW	
Starting times (times/min.)	5	4	3	2	

Duty factor (%ED) = $\frac{\text{Operation time per cycle} \times 100\%}{\text{Operation time per cycle} + \text{Pausing time}}$
 (formula 3)

Coasting and Stopping accuracy

- Coasting means the running distance of the cylinder during the time between the actuation of the stopping button and the complete stop of the cylinder.
- Stopping accuracy means the variation of the stopping point when the movement of the cylinder is repeated. The faster the speed is the longer the coasting distance and the worse the stopping accuracy.

Brake

- Brake torque of motor for Mighty Cylinder is 150% or more. Brake power is larger than the rated thrust power, so it is quite safe to hold the load.
- Magnetic brake with spring enables the Mighty Cylinder to hold the load in case of power failure.
- Manual release device is equipped except for 0.2kW. As to 0.2kW, please operate the handle as it is because there is no manual release device.

	(table 9)			
Control method	Simultaneous cutoff of brake		Individual cutoff of brake	
Direction of load	Pushing up load	Suspension load	Pushing up load	Suspension load
± Stopping accuracy (mm)/speed(mm/sec)	±0.04	±0.06	±0.02	±0.04

(example) In case of simultaneous cutoff, pushing up load and the speed of 30mm/sec, stopping accuracy shall be ±1.2mm (±0.04×30).

■ Selection

● Prevention for rod rotational torque

1. Reciprocation by screw mechanism generates rotational torque on the piston rod. Rotational torque shown on the table 1 expresses torque at the rated thrust power. It varies depending on the thrust power.
2. In case the knuckle joint can not be connectd to the mate machine or the device to prevent the turning torque, we are to prouduce the Mighty Cylinder with the device.
3. When positive large rotational power works and the accuracy toward the rotational direction of the rod is required, equip the mate machine with the mechanism to prevent the turning torque of the piston rod.

● Manual operation

Remove the protection cap for manual shaft and release the brake of motor, when the cylinder is operated manually. Remove the load when it works on the rod, before the release of brake. 0.2kW has no brake.

■ Installation

- Installation direction is free (horizontal, vertical, oblique etc.).
- Installation method for main body shall be trunnion mount or clevis mount.
- The connection between the knuckle joint and the mate machine and the trunnion pin or clevis pin shall be same directionally.
- Check the accuracy of the installation position against the pin of the knuckle joint to avoid the lateral load.
- The connection gap between in width the knuckle joint and the mate machine shall be 1mm or more.
- When the connecting mate is arm or things like that, there may be a fear of trouble of rod bending by interfering the allowance of the knuckle joint. Consideration of the arm shape is required. We are ready to meet the special shape of the knuckle joint.

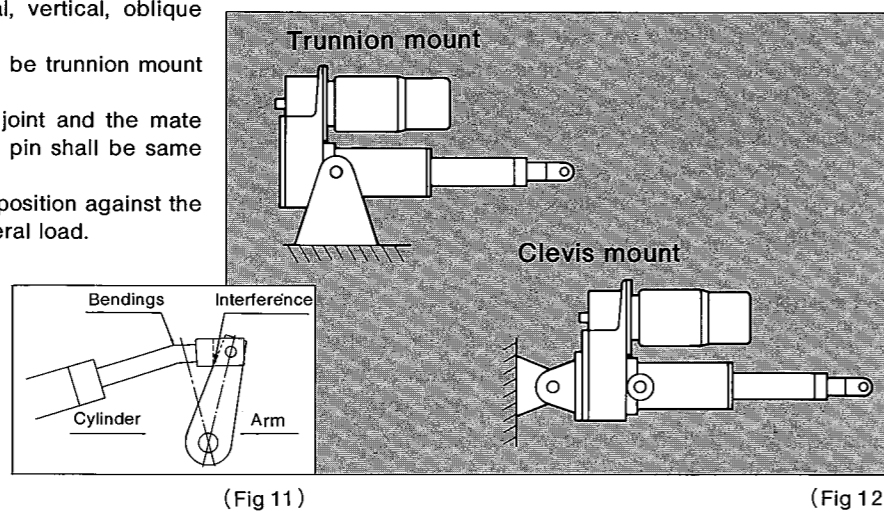

■ Maintenance

MC series Mighty Cylinder can be used as it is because grease is supplied on the necessary parts before shipment. The kind of grease and the supply cycle are as follows.

● Screw part

Screw and nut are applied with grease beforehand. As for supply cycle and recommended grease, refer to the table 10 and 11.

● Thrust part

Radial bearings are the grease-sealed type. The type combined with thrust bearing and radial bearing shall be supplied from the grease nipple.

● Gear box

Grease is applied. There is no need to apply grease for 1 year under the normal operation. Check and supply grease if necessary when the cylinder is operated or left unoperated for a long time.

● Synchronization accuracy

Synchronization accuracy varies depending on the variation of load. It is around 5%. In case perfect synchronization is required, please examine SC series.

● Lateral load on the rod

1. Make sure lateral load does not actuate on the cylinder. Lateral load shall result in causing the bending, damage of the piston rod and screw which invite the lowering of the thrust power.
2. Please contact us if it is impossible to avoid the use which incur the lateral load. We are ready to cope with it by reinforcing the rod and guide.

● Control method

When the plural cylinders are operated simultaneously, equip every cylinder with limit switches for positioning. In this case control circuit shall be simultaneous start and individual stop. Simultaneous stop shall be avoided because it will result in the accumulated error.

● Grease supply cycle

(table 10)

Frequency	Supply cycle
500~1000 times/day	3~6 months
100~500 times/day	6 months~1 year
10~100 times/day	1 year~1.5 year

● Recommended grease

(table 11)

Company name	Grease nomination
New Nippon Sekiyu	EPNOC GREASE AP-1
Mobil Sekiyu	PLEX No.46
Idemitsu Kousan	DAPHNE EPONEX SRNo.1
Cosmo Sekiyu	DYNAMAX SHNo.1
Showa Shell Sekiyu	SHELL ALVANIA EPNNo.1

■ Wiring

● Wiring of brake motor

(Fig 13)

MH : Power unit is built in. In case of individual cutoff, unscrew the connecting screw.

In case of 3.7kW or less

MH (power unit) is built in the motor.

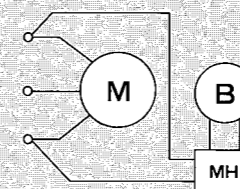

In case of 5.5kW or more, MH power unit is not built in the motor. It shall be installed in the control box.

In case of 5.5kW or more

MH (power unit) is not built in the motor. It shall be installed in the control box.

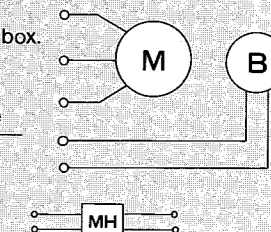

● Specifications of limit switches

Never fail to wire the limit switches for the thrust limiter which are built in the Mighty Cylinder. If the limit switches for the advancement and for the retreat are wired vice versa, motor may burn out or the inside of the cylinder may be broken by locking phenomenon.

■ Specifications of limit switches

(table 12)

	for outer positioning	for thrust detection
electric capacity	AC250V, 10A	AC250V, 10A
Contact composition	NC1, NC2, 3NO, 4NO	LS01, LS02, 3, 4, 5, 6

● Basic Circuit

Single operation circuit (Individual cut off)

Plural operation circuit

(Fig 16)

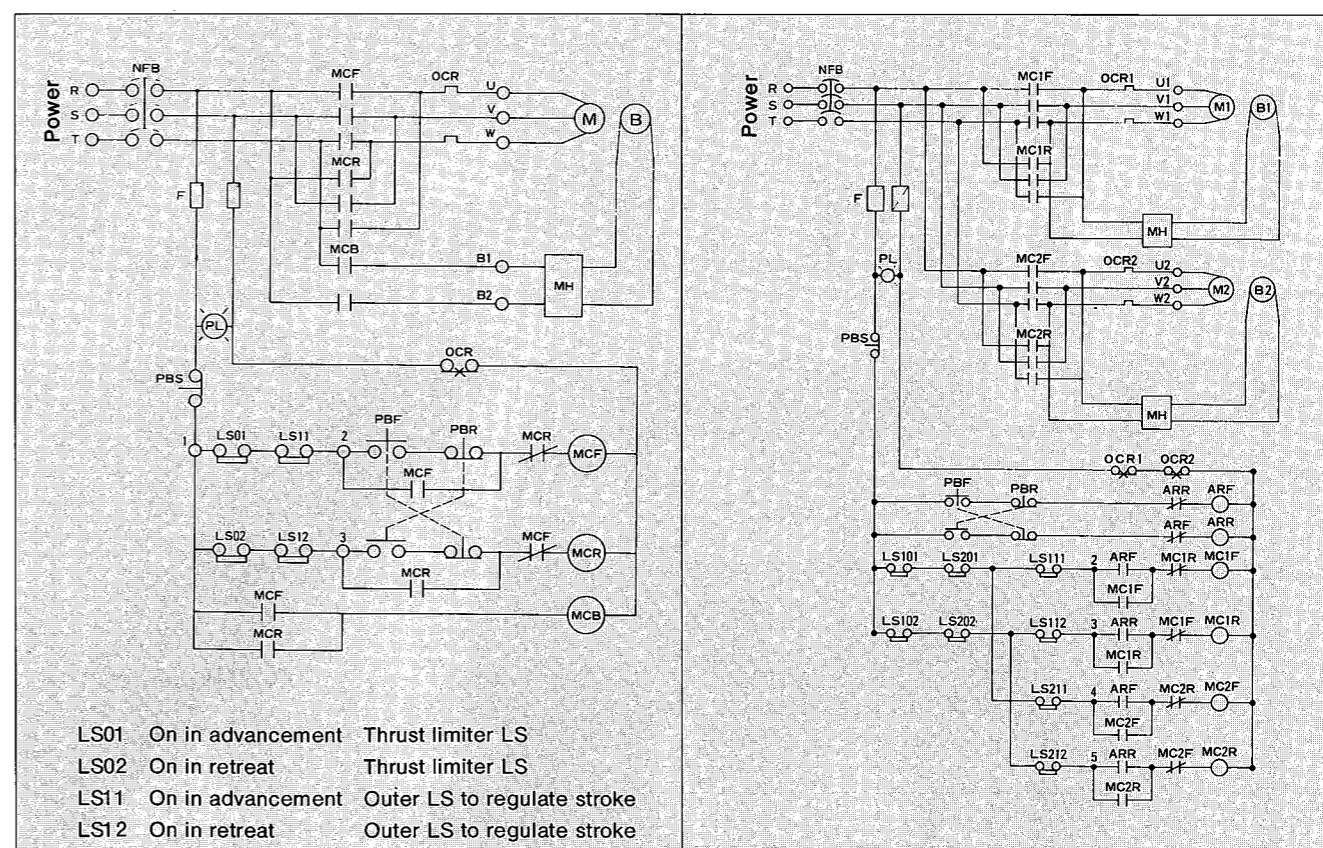

- LS01 On in advancement Thrust limiter LS
- LS02 On in retreat Thrust limiter LS
- LS11 On in advancement Outer LS to regulate stroke
- LS12 On in retreat Outer LS to regulate stroke

Outline drawing (mm)

MCSLB 01 03
MCSLBB 01 03

Economic type with genuine straight shape is available. Please contact us if necessary.

Stroke	C	Without bellows		With bellows	
		min L	Weight	min L	Weight
100	238	308	31	308	31
200	338	408	32	408	32
300	438	508	33	508	33
500	638	708	34	785	35
700	878	948	35	1061	37

Trunion metal (MC03-T)

MCSLC 05

Stroke	C	Without bellows		With bellows	
		min L	Weight	min L	Weight
100	273	343	36	343	36
200	373	443	37	443	37
300	473	543	38	543	38
500	673	743	40	820	41
700	913	983	43	1096	45

Trunion metal (MC05-T)

MCSLD 1

Stroke	C	Without bellows		With bellows	
		min L	Weight	min L	Weight
200	378	473	49	473	49
300	478	573	50	573	50
500	678	773	52	840	53
700	918	1013	55	1116	57
1000	1218	1313	58	1499	61

Trunion metal (MC1-T)

Outline drawing

MCLB 01 03

Stroke	C	Without bellows		With bellows	
		min L	Weight	min L	Weight
100	238	308	32	308	32
200	338	408	33	408	33
300	438	508	34	508	34
500	638	708	36	785	37
700	878	948	39	1061	41

Clevis metal (MC03-C)
Trunion metal (MC03-T)

MCL 05

Type	A	B	E	G	H	MD	ML	GW
MCLB05	60	110	102	72	359	127	201	120
MCLC05	77	135	113	86	384	142	284	154

Stroke	C	min L		Without bellows rough weight (kg)		Weight addition for bellows
		Without bellows	With bellows	MCLB05	MCLC05	
100	273	343	343	34	34	—
200	373	443	443	35	35	—
300	473	543	543	36	36	—
500	673	743	820	38	39	0.12
700	913	983	1096	41	43	0.18

Clevis metal (MC05-C)
Clevis metal MC1-C shall be used for MCLC05 dimension is shown within ()
Trunion metal (MC05-T)

■ Outline drawing

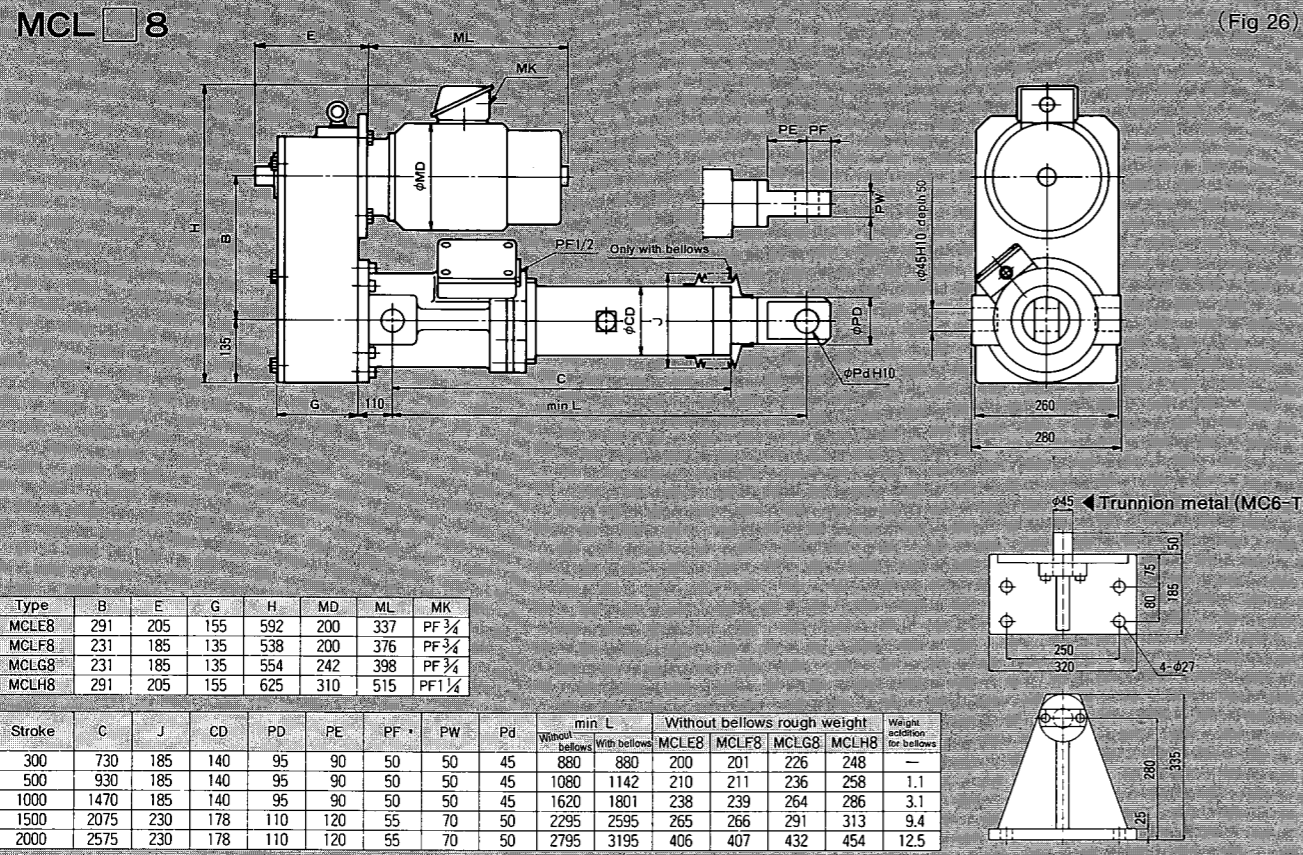

■ Outline drawing

