

# Roller screws catalogue





# Contents

<b>1 Introduction</b> .....	<b>6</b>	Calculation example.....	47
Introduction to roller screws.....	7	<b>3 Product range</b> .....	<b>51</b>
Ewellix roller screws, high performance driving solutions	7	Planetary roller screws SR.....	52
Product overview .....	8	Ultra Power roller screws HR.....	76
Preferred range .....	9	Inverted roller screws ISR.....	86
Planetary roller screws with standard nuts in stock.....	10	Rotating nut with planetary roller screws SRR .....	90
Recirculating roller screws with standard nuts in stock..	10	Recirculating roller screws SV .....	94
Selection guide .....	12	Support bearings FLRBU .....	104
Typical applications for roller screws .....	18	Ordering key.....	113
<b>2 Selection guide</b> .....	<b>20</b>	<b>4 Mounting instruction</b> .....	<b>114</b>
Technical concepts.....	21	Recommendations for assembly.....	115
Introduction to Ewellix roller screws .....	21	Handling.....	115
Basic dynamic load carrying capacity $C_a$ .....	21	Storage .....	115
Nominal fatigue life $L_{10}$ .....	21	Nut disassembly.....	115
Service life .....	22	Lubrication.....	117
Equivalent dynamic load $F_m$ .....	22	Starting up the screw .....	117
Basic static load carrying capacity $C_{0a}$ .....	22	Running in period .....	117
Critical rotating speed for screw shafts $n_{cr}$ .....	23	Monitoring screw life .....	117
Permissible speed limit		Traceability .....	117
( $n$ $d_0$ ) and acceleration.....	23	Support bearings assembly .....	117
Efficiency $\eta$ .....	24	Recommendations for bolts used with flanged nuts.....	117
Back-driving and braking		Alignment.....	117
torque $T_b$ .....	25	Lubrication .....	119
Break away torque $T_x$ .....	25	Lubrication for roller screws.....	119
Driving torque $T_t$ .....	25	Grease lubrication .....	120
Static axial stiffness $R_t$ .....	25	Oil lubrication.....	125
Materials, heat treatment and coatings .....	26	Wipers.....	125
Operating temperature .....	27	Dry lubricants .....	126
Screw shaft buckling or column strength $F_c$ .....	27	<b>5 Technical request form</b> .....	<b>127</b>
Shaft design .....	28	<b>6 Symbols</b> .....	<b>130</b>
Product inspection and certification .....	29		
Working environment .....	29		
Axial play and preload .....	30		
Axial play and preload.....	30		
Preload and stiffness.....	30		
Preload torque $T_{pr}$ .....	32		
Preload torque tolerances .....	32		
Preload adjustment .....	34		
Lead precision and manufacturing tolerances.....	36		
Lead precision .....	36		
Manufacturing tolerances .....	40		
Calculation formulae.....	44		

# The heritage of innovation

Ewellix is a global innovator and manufacturer of linear motion and actuation solutions. Today, our state-of-the-art linear solutions are designed to increase machine performance, maximise uptime, reduce maintenance, improve safety and save energy.

## Technology leadership

Our journey began **over 50 years** ago as part of the SKF Group, a leading global technology provider, with the world's first precision ball and roller screw factories. Our history with SKF provided us with the **expertise to continuously develop new technologies** and use them to create cutting edge products that offer our customers a competitive advantage.

In 2019, we became independent from SKF and changed our name to Ewellix. **We are proud of our heritage.** This gives us a unique foundation on which to build an agile business with engineering excellence and innovation as our core strengths.

## Global presence and local support

With our **global presence**, we are uniquely positioned to deliver **standard components and custom-engineered solutions**, with full technical and applications support around the world. The long lasting relationships with our distributor partners allow us to support customers in a variety of different industries. At Ewellix, we don't just provide products; **we engineer integrated solutions** that help customers realise their ambitions.



**1 400 employees**



**16 sales units**



**9 factories**

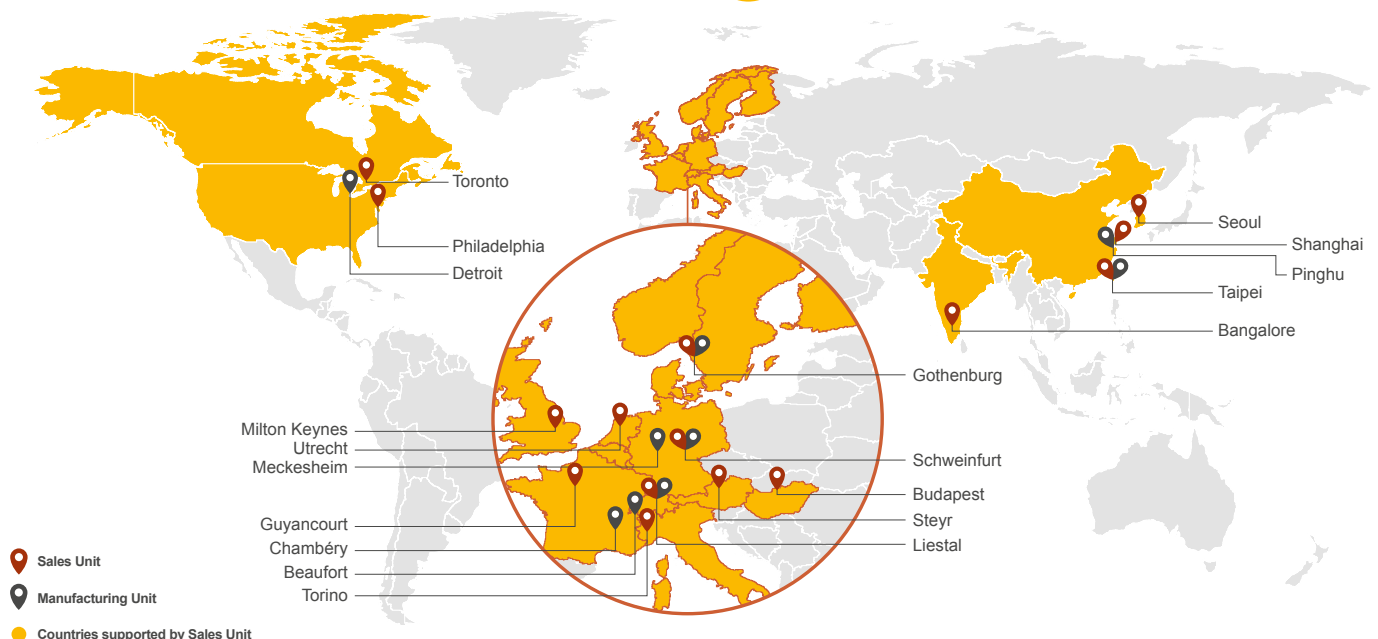

# Trusted engineering expertise

Our industry is in motion; pushing towards solutions that reduce environmental impact and leverage new technology.

We provide technical and manufacturing expertise to overcome our customers' challenges.

## Engineering for the future

We work in a **wide range of industries**, where our solutions provide key functionality for business critical applications.

For the **medical industry**, we provide precision components for use in core medical equipment.

Our unparalleled understanding of **industrial automation** systems is based on decades of research into advanced automation components and techniques

Our deep knowledge of **mobile machinery** provides powerful and reliable electromechanical solutions for the harshest conditions. In an **industrial distribution** setting, we supply linear expertise to our partners, empowering them to serve customers with greater efficiency

## We offer excellence

We have a **unique understanding of linear equipment** and how it's integrated in customers' applications to provide the best performance and machine efficiency.

**We assist our customers** by creating equipment that runs faster, longer and that is safe and sustainable.

We provide a wide variety of **linear motion components** and **electromechanical actuators** for equipping any automation application, helping our customers **reduce footprint, energy use and maintenance**.

We push for lower energy consumption that **increase productivity and reduce the environmental impact**.

Actuation systems



Ball and roller screws



Linear guides and systems

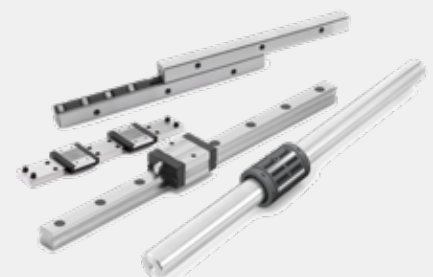

1

# Introduction

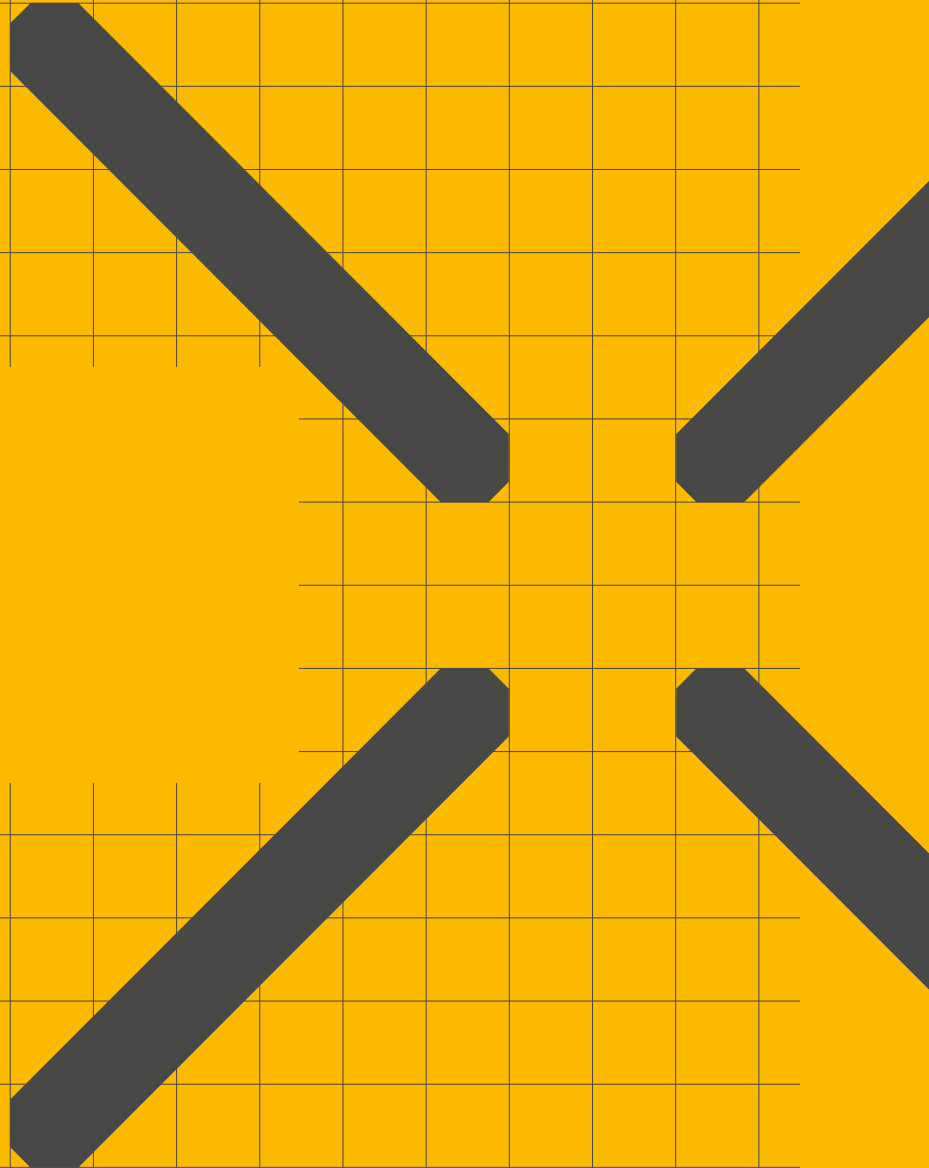

# Introduction to roller screws

## Ewellix roller screws, high performance driving solutions

A wide assortment of industries rely on Ewellix roller screws for their actuation requirements. Leading the trend to move from traditional forms of linear actuation, Ewellix roller screws represent the state of the art driving force for powerful electro-mechanical actuation.

Ewellix is a pioneer in the technology of roller screws and offers high quality, high performance and the widest assortment of roller screws available on the market.

The Ewellix in-house highly integrated manufacturing process uses the latest machining technology including soft and hard machining, heat treatment (induction and through hardening), grinding and assembly operations. Ewellix manufacturing facilities also house laboratories dedicated to life tests, tribology, noise measurement and metallurgy. Beyond the standard assortment made from high grade bearing steel, Ewellix offers special variants with stainless steel and high temperature steel combined with coatings, etc. to respond to the most demanding applications.

Ewellix offers three main variants of planetary roller screws that do not require roller recirculation:

- The traditional SR assortment with threaded rollers synchronized to the nut, thanks to identical helix angle for the rollers and the nut
- The HR Ultra Power roller screws with increased capabilities compared to the SR assortment
- The ISR inverted roller screws with threaded rollers synchronized to the screw shaft, thanks to identical helix angle for the rollers and the shaft.

In addition, Ewellix offers special variants of planetary roller screws:

- The SRR rotating nut roller screws
- Zero lead roller screws that can advantageously replace a traditional thrust bearing solution when extreme axial load carrying capacity, low weight and compactness are required.

Ewellix offers a wide assortment of recirculating roller screws. Since the rollers are circumferentially grooved, after each complete revolution around the nut, the grooved rollers must be recirculated back to their starting point on one side of the nut, with the help of cams and axial groove inside the nut.

Small leads are possible with a relatively larger thread pitch on the shaft and nut. This feature offers the ideal combination of small lead, high load carrying capacity, a high degree of stiffness and precision.

Nevertheless, the recirculating roller screws present lower speed and acceleration capabilities than planetary roller screws.

# Product overview



**Planetary roller screws SR**  
 Wide assortment of diameters and leads for numerous applications  
 Reliable driving solution with high loads and speeds capabilities



**Ultra Power planetary roller screws HR**  
 Extreme load carrying capacity  
 Robustness and long service life for highly demanding applications



**Inverted planetary roller screws ISR**  
 All the features and benefits of the planetary roller screw design  
 Plus small leads, high load carrying capacity within a compact design



**Rotating nut planetary roller screws SRR**  
 Operation similar to electro-mechanical cylinders  
 Compact, integrated support bearing and roller screw nut functions



**Zero lead roller screws**  
 Thrust bearing solution for special applications  
 High thrust carrying capacity with compactness



**Recirculating roller screws SV**  
 Small leads associated with high load carrying capacity  
 Fine resolution and stiffness for ultra precision applications

Expectations with electro-mechanical actuation	Ewellix roller screw solutions
Increased productivity for industrial grade applications with operational duty cycle over 70%	High load carrying capacity and cycling capability Accommodate high accelerations and high speeds
Up to 70% energy savings compared to hydraulic and pneumatic actuation technologies	Mechanical efficiency usually greater than 80%
Functionality, flexibility and controllability	Widest assortment of roller screws available on the market Accommodate heavy loads with transportation applications Provide accuracy for positioning applications Custom designs and flexible manufacturing equipment
Reliability	By design, the planetary roller screw offers greater reliability than other driving solutions
Higher repeatability and process stability	Limited wear, in particular for screws that have been run in at the factory
Easy integration into work cells and existing systems	High power density
Higher degree of precision	High degree of positioning accuracy further increased without backlash or with preload Recirculating roller screws with small leads are recommended for ultra-precision applications
Low noise levels	Very smooth and quiet operation with planetary roller screws
Cleanliness	Roller screws consume a very small amount of lubricants
Lower total cost of ownership (TCO) compared to traditional types of actuation	Long service life and reliability

# Preferred range

The Ewellix preferred range encompasses the most frequently used sizes of planetary roller screws and recirculating roller screws. Within that assortment, standard size nuts are stocked at Ewellix factories in Europe and North America for improved availability, greater value, and shorter delivery times. Shafts are manufactured according to customer requirements.

<b>Design and manufacturing operations</b>	<ul style="list-style-type: none"> <li>- Standard roller screws with standard and maximum load ratings are available with axial play (SR or SV prefix), or without backlash (BR or BV prefix)</li> <li>- Nut dimensions are detailed hereafter</li> <li>- Standard shaft end machining can include turning, milling and grinding operations</li> <li>- End machining is available for Ewellix support bearings</li> </ul>
<b>Materials</b>	<ul style="list-style-type: none"> <li>- For the preferred range, shafts and nuts are manufactured with standard high quality roller screw steel, detailed in the present Ewellix catalogue Roller screws</li> <li>- Stainless steel and special treatments are not available with the preferred range</li> </ul>
<b>Capabilities</b>	<ul style="list-style-type: none"> <li>- Machining operations such as splines, hollow shaft, etc. are possible, but might require more time to complete</li> <li>- Unless specified, manufacturing tolerances will be according to ISO 3408-3 class 5</li> <li>- Lead precision is G5 according to ISO standards. G3 and G1 also possible on request</li> <li>- Screw assemblies are shipped with a protective rust inhibitor coating</li> <li>- Special documents can be supplied on request: Certificate of conformity to customer drawings # 1969981, lead precision curve</li> <li>- Matching FLRBU support bearings size 2 to 6 can be delivered with the screws</li> </ul>
<b>Export note</b>	<ul style="list-style-type: none"> <li>- Product for nuclear, aerospace or military applications may be subject to export restrictions and/or licensing requirements. In such cases, delivery time shall be dependent upon securing approvals from the appropriate governmental authority.</li> </ul>

## Planetary roller screws with standard nuts in stock

- SRC cylindrical nut with axial play
- BRC cylindrical nut without backlash
- SRF flanged nut with axial play
- BRF flanged nut without backlash
- SRC/BRC/SRF/BRF nuts with wiper recesses as standard
- Standard wipers supplied on request
- Right handed thread only
- Standard or maximum number of rollers available

SRC/BRC cylindrical nut with wipers

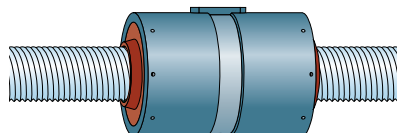

SRF/BRF flanged nut with wipers

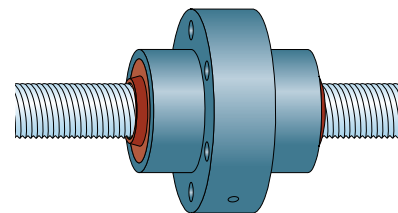

Nominal diameter	Lead	Basic load rating				Nut type available	Maximum total shaft length
		$C_a$	$C_{0a}$	$C_{amax}$	$C_{0amax}$		
$d_0$ mm	$P_h$ Unit	$C_a$ kN	$C_{0a}$	$C_{amax}$	$C_{0amax}$		$L_{tp}$ mm
15	5	26	43,6	29,7	53,3	SRC/BRC	975
15	8	27,4	40,8	29,4	45,3	SRC/BRC	975
21	5	50,6	82	57,8	100	SRC/BRC/SRF/BRF	1 400
21	8	57	84,1	65,2	103	SRC/BRC	1 400
21	10	59,2	83	63,6	92,2	SRC/BRC/SRF/BRF	1 400
25	5	68,4	122	72,2	149	SRC/BRC	1 650
25	10	78,6	118	89,9	145	SRC/BRC	1 650
30	5	92	178	105	218	SRC/BRC/SRF/BRF	2 000
30	10	106	174	122	213	SRC/BRC/SRF/BRF	2 000
39	5	129	269	129	269	SRC/BRC/SRF/BRF	2 650
39	10	153	271	153	271	SRC/BRC/SRF/BRF	2 650
48	5	198	482	198	482	SRC/BRC/SRF/BRF	3 300
48	10	232	475	232	475	SRC/BRC/SRF/BRF	3 300
48	20	266	462	394	565	SRC/BRC/SRF/BRF	3 300
60	20	395	787	452	960	SRC/BRC/SRF/BRF	4 250

## Recirculating roller screws with standard nuts in stock

- SVC cylindrical nut with axial play
- BVC cylindrical nut without backlash
- SVC/BVC nuts without wiper recess,
- no wiper availability

SVC/BVC cylindrical nut

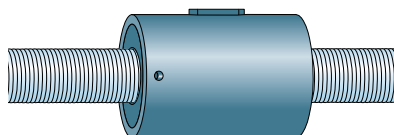

Nominal diameter	Lead (right hand)	Basic load rating SVC/BVC nut		Maximum total shaft length
		$C_a$	$C_{0a}$	
$d_1$ mm	$P_h$	$C_a$ kN	$C_{0a}$	$L_{tp}$ mm
20	1	18,5	36,6	1 300
25	1	32,9	68,4	1 650
32	1	64,3	159	2 150
32	2	64,3	159	2 159

With planetary roller screws, the application load is transmitted from the nut to the shaft through the barrel-shaped surfaces of the rollers. The number of contacts and the total surface area of the contacts between the shaft, the rollers and the nut are substantially increased compared to the ball screw design, resulting in larger dynamic and static load carrying capacities (↳ **fig. 1**).

The absence of recirculating element embodies the fundamental conceptual advantage of the planetary roller screws. This feature eliminates the main failure mode of ball screws, that is linked to the recirculation of the balls. Indeed, recirculating heavily loaded balls induces alternate stresses on the balls and shock loads arising from the change of trajectory.

In addition, satellite rollers never come into contact with each other. This is a significant advantage of this product over most ball screw designs. Balls come into contact with each other in most ball screw designs, generating friction and adding a potential failure mode to the ball screw concept.

With recirculating roller screws, the application load transfers from the shaft to the nut through a set of grooved rollers. This design permits very small leads while offering high load carrying capacity and axial stiffness.

This mechanical advantage minimizes input torque and increases application resolution and performance. They can simplify a complete transmission and improve its rigidity. They are often used in applications involving advancing technology where reliable optimum performance is essential.

**Fig. 1**  
Comparison of ball screws and roller screws contact area

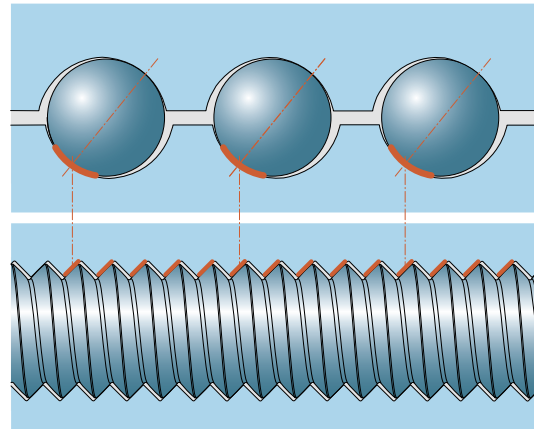

Roller screw concept	Advantages over a ball screw	User benefits
Large number of contact points	High load carrying capacity and up to 10 times longer service life	Lower total cost of ownership (TCO)
Satellite rollers	Roller screw rotational speeds up to 50% higher than a ball screw with similar carrying capacity	Increased speed of operations
	Roller screw acceleration up to 3 times higher	Higher productivity
Planetary roller screws with small lead (down to 2,00 mm)	Absence of recirculation eliminating a significant failure mode	Higher degree of reliability
	High load carrying capacity compared to ball screws with small lead which are designed with small diameter balls which have low load carrying capacity	High load carrying capacity combined with positioning accuracy and reduced torque requirements
Evenly spaced planetary or recirculating rollers	Good operation in applications with changes of direction, stable friction torque	Low noise High degree of reliability
Recirculating roller screws with small lead down to 1 mm	High load carrying capacity, high axial stiffness that cannot be obtained with a ball screw of similar lead and diameter Very small input torque	High resolution, high stiffness, long service life, robustness

# Selection guide

Planetary roller screws SR/BR, HR: Standard and maximum dynamic load carrying capacity  $C_a$  [kN]

Nominal diameter $d_0$ mm	Nut type	Lead [mm]																		
		2 kN	4	5	6	8	9	10	12	15	18									
8	SR/BR	8,61	8,93																	
12	SR/BR	–		14,1																
12	SR/BR	13,2		15,1																
15	SR/BR	–		26				27,4												
15	SR/BR	23,9		29,7				29,4												
18	SR/BR	30,4		37,7				38												
21	SR/BR	–		50,6	52,8			57		59,2										
21	SR/BR	47,4		57,8	60,3			65,2		63,6										
24	SR/BR				42,3						47,7									
24	SR/BR				47,3						53,3									
25	SR/BR			68,4			76,1			78,6						85,6				
25	SR/BR			78,2			87			89,8						91,9				
30	SR/BR			92	95		103			106						119				
30	SR/BR			105	109		117			122						127				
36	SR/BR				90,5			97,5			107					114				
36	SR/BR				106			115			125					128				
39	SR/BR			129						153						168				
39	SR/BR			148						174						192				
44	SR/BR						130				144					158				
44	SR/BR						153				169					185				
48	SR/BR			198			218			232						258				
48	SR/BR			240			250			265						295				
56	SR/BR										212									
56	SR/BR										249									
60	SR/BR									339						373				
60	SR/BR									387						426				
60	HR															494				
64	SR/BR																		317	
64	SR/BR										296								333	
75	SR									505						561				
75	HR															836				
80	SR									365									420	
80	SR									383									441	
87	HR																		1 059	
99	SR																			
99	HR																		1 277	
112,5	HR																		1 396	
120	SR																			
120	HR																		1 547	
135	HR																		1 843	
150	HR																		2 200	
180	HR																		3 073	
210	HR																			
240	HR																			

Standard number of rollers  
 Maximum number of rollers, on request  
 Preferred range

Nominal diameter $d_0$ mm	Nut type	20	24	25	30	35	36	40	42	50
		kN								
8	SR/BR									
12	SR/BR									
12	SR/BR									
15	SR/BR									
15	SR/BR									
18	SR/BR									
21	SR/BR									
21	SR/BR									
24	SR/BR									
24	SR/BR									
25	SR/BR									
25	SR/BR									
30	SR/BR	123								
30	SR/BR	132								
36	SR/BR		124							
36	SR/BR		138							
39	SR/BR	173		175						
39	SR/BR	198		188						
44	SR/BR		168		166					
44	SR/BR		188		185					
48	SR/BR	266		286	276					
48	SR/BR	304		327	316					
56	SR/BR		242				258			
56	SR/BR		284				289			
60	SR/BR	395								
60	SR/BR	452								
60	HR	515		530	528					
64	SR/BR		329		318		309			
64	SR/BR		346		356		346			
75	SR	572								
75	HR	845		855	852					
80	SR		452					398		
80	SR		474					445		
87	HR	1 061		1 085	1 085					
99	SR	925		937						
99	HR	1 311		1 328	1 330	1 329				
112,5	HR	1 421		1 446	1 455	1 461				
120	SR	1 131		1 127						
120	HR	1 587		1 585	1 614	1 640	1 651			
135	HR	1 858		1 903	1 904	1 921	1 909		1 944	
150	HR	2 240		2 137	2 167	2 167	2 176		2 189	
180	HR	3 123		3 002	3 009	3 023	3 075		3 128	
210	HR	3 371		3 435	3 249	3 265	3 322		3 381	
240	HR			3 919	3 931	3 994	3 808		3 860	

SR (C, F or P): Planetary roller screw with axial play

BR (C, F or P): Planetary roller screw without backlash

HR (C, F or P): Ultra Power planetary roller screw

C: Cylindrical nut, F: Centered flange, P: Off-centered flange

**Planetary roller screws PR, with internal preload: Standard and maximum dynamic load carrying capacity C<sub>a</sub> [kN]**

Nominal diameter d <sub>0</sub> mm	Nut type	Lead [mm]										
		2 kN	4	5	6	8	9	10	12	15	18	
8	PR	4,74	4,92									
12	PR	–		7,76								
12	PR	7,25		8,32								
15	PR	–		14,3		15,1						
15	PR	13,1		16,4		16,2						
18	PR	16,8		20,8		20,9						
21	PR	–		27,9	29,1	31,4			32,6			
21	PR	26,1		31,8	33,2	35,9			35,0			
24	PR				23,3					26,3		
24	PR				26,1					29,4		
25	PR			37,7		41,9			43,3		47,2	
25	PR			43,1		47,9			49,5		50,6	
30	PR			50,7	52,3	56,5			58,6		65,4	
30	PR			57,9	59,8	64,6			67,0		70,1	
36	PR				49,8		53,7			58,7		62,9
36	PR				58,5		63,1			69,0		70,3
39	PR			71,2					84,1		92,4	
39	PR			81,4					96,1		106	
44	PR					71,9				79,2		86,9
44	PR					84,4				93,0		102
48	PR			109		120			128		142	
48	PR			132		138			146		162	
56	PR									117		
56	PR									137		
60	PR								187		206	
60	PR								213		235	
64	PR									–		177
64	PR									166		186

- Standard number of rollers
- Maximum number of rollers, on request

PR (U or K): Planetary roller screw with preloaded split nut  
 U: Cylindrical nut, K: Centered flange

Nominal diameter $d_0$ mm	Nut type –	Lead [mm]					
		20 kN	24	25	30	35	36
8	PR						
12	PR						
12	PR						
15	PR						
15	PR						
18	PR						
21	PR						
21	PR						
24	PR						
24	PR						
25	PR						
25	PR						
30	PR	67,9					
30	PR	72,9					
36	PR		68,1				
36	PR		76,1				
39	PR	95,2		96,3			
39	PR	109		103			
44	PR		92,5		91,4		
44	PR		103		102		
48	PR	146		157	152		
48	PR	167		180	174		
56	PR		133				142
56	PR		157				159
60	PR	218					
60	PR	249					
64	PR		184		178		173
64	PR		193		199		193

**Inverted roller screws ISR/IBR: Standard dynamic load carrying capacity  $C_a$  [kN]**

Nominal diameter $d_0$ mm	Nut type	Lead [mm]				
		2,4 kN	3	4	5	6
18	ISR/IBR	35,6	37,8	36,6	37,8	40,4
21	ISR/IBR	55,5	59,6	63,3	61,5	64,2
24	ISR/IBR	63,7	67,2	72	75,3	74,5
30	ISR/IBR	93,2	99,2	105	111	117
39	ISR/IBR	135	143	153	161	169
48	ISR/IBR	209	221	234	247	259

ISR: Inverted roller screw with axial play  
 IBR: Inverted roller screw without backlash

**Rotating nut roller screws SRR/BRR: Standard dynamic load carrying capacity  $C_a$  [kN]**

Nominal diameter $d_0$ mm	Nut type	Lead [mm]				
		5 kN	10	15	20	25
25	SRR/BRR	68,4	78,5	85,6		
30	SRR/BRR	91,9	106	119	123	
39	SRR/BRR	129	153	168	173	175
48	SRR/BRR	198	232	258	266	286
60	SRR/BRR		339	373	395	

SRR: Rotating nut roller screw with axial play  
 BRR: Rotating nut roller screw without backlash

**Recirculating roller screws SV/BV: Standard dynamic load carrying capacity  $C_a$  [kN]**

Nominal diameter $d_1$ mm	Nut type	Lead [mm]				
		1 kN	2	3	4	5
8	SV/BV	8,5				
10	SV/BV	8,95	8,95			
12	SV/BV	10,3	10,3			
16	SV/BV	11,5	11,5			
20	SV/BV	18,5	18,5			
25	SV/BV	32,9	32,9			
32	SV/BV	64,3	64,3			
40	SV/BV	79,1	49,9			
50	SV/BV	190	98,1	153	98,1	
63	SV/BV		186		186	
80	SV/BV				325	
100	SV/BV					469
125	SV/BV					756

■ Preferred range

SV (C or F): Recirculating roller screw with axial play

BV (C or F): Recirculating roller screw without backlash

C: Cylindrical nut, F: Centered flange

**Recirculating roller screws PV, with internal preload: Standard dynamic load carrying capacity  $C_a$  [kN]**

Nominal diameter $d_1$ mm	Nut type	Lead [mm]				
		1 kN	2	3	4	5
8	PV	4,88				
10	PV	5,14	5,14			
12	PV	5,96	5,96			
16	PV	6,71	6,71			
20	PV	10,6	10,6			
25	PV	18,9	18,9			
32	PV	36,9	36,9			
40	PV	45,4	28,7			
50	PV	109	56,3	88	56,3	
63	PV		107		107	
80	PV				187	
100	PV					269
125	PV					434

PV (U or K): Recirculating roller screw with preloaded split nut

U: Cylindrical nut, K: Centered flange

# Typical applications for roller screws

## Application examples

## Why Ewellix customers choose roller screw technology



### Plastic moulding

Injection moulding, blow moulding, thermo-forming

Improved machine productivity, energy savings, cleanliness.

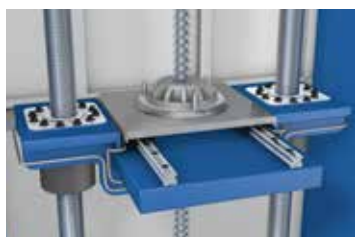

### Broaching

Automotive and aircraft industries

Smooth continuous cutting operation. A high degree of stiffness provides a better surface finish for the part.

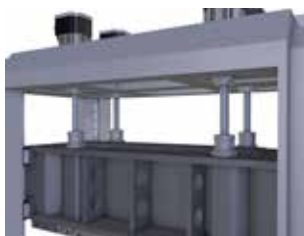

### Electro-mechanical press

Top slide and die cushion for forming press  
Punching press

Dynamic load rating up to 4 000 kN, the force of hydraulic actuation, the speed of pneumatic actuation.



### Factory automation

Gluing, riveting, welding, clinching, joining, bending, clamping, etc.

Accurate and repeatable, faster resetting, energy savings, reduced downtime, cleanliness, compactness.



### Oil & gas industry

Surface and subsea valves, downhole tools, offshore equipment

Robust, compact, high power density and high temperature rating.

## Application examples

## Why Ewellix customers choose roller screw technology



### Aerospace

Aileron, flap, slat, landing gear, wheel steering, ram air door, thrust reverser

Efficiency, reliability, weight saving, compact.



### Railway

Titling actuators, active suspension

Reliability, robustness, low maintenance.



### Steel industry

Tundish car, ladle turret, continuous casting

High power density, high degree of reliability in extremely harsh environments.

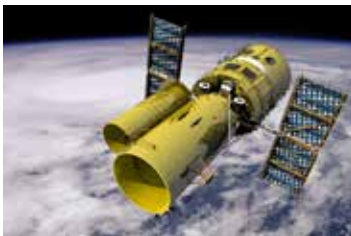

### Space and telescope

Optical focus, mirror shape control, solar arrays release

High resolution, precision and stiffness.



### Simulator

Flight simulator, wave simulator, engineering test benches, entertainment equipment

High speeds and accelerations, fast and accurate positioning and response.

2

**Selection guide**



# Technical concepts



## Introduction to Ewellix roller screws

Roller screws convert rotary motion into linear motion and vice-versa. Loads are transferred from the screw shaft to the nut through a roller set, therefore, roller screws relate to general bearing technology. Various types of bearing steel are used to attain the hardness and material fatigue properties required for carrying heavy application loads over extended periods of service. Certain bearing concepts such as load ratings, load cycles, nominal calculated life and service life, stiffness, speed ratings, lubrication requirements, etc. are explained below to guide customers through the roller screw selection process. The selection parameters are included in this chapter. To make the best selection of a roller screw, the designer should consider the following parameters such as the load cycle, the linear or rotational speed, the required life, the rates of acceleration and deceleration, the cycle rate, the environment, the lead accuracy, the stiffness, and any other special requirements.

For additional information about the roller screws selection process, please contact your local Ewellix representative.

## Basic dynamic load carrying capacity $C_a$

The dynamic load carrying capacity is used to compute the nominal fatigue life of roller screws. It corresponds to the axial load, constant in magnitude and direction, concentric with the roller screw axis, under which the calculated nominal fatigue life as defined by ISO 3408–5 reaches one million revolutions.

## Nominal fatigue life $L_{10}$

Nominal fatigue life  $L_{10}$  is, according to the ISO definition, the life attained or exceeded by 90% of a sufficiently large group of identical roller screws, working under identical conditions (alignment, axially and centrally applied load, speed, acceleration, lubrication, temperature and cleanliness).

The nominal life of a roller screw is the statistical number of millions of revolutions which the roller screw is capable of reaching before the first signs of flaking signifying material fatigue occurs on one of the rolling surfaces.

When reliability greater than 90% is required, the calculated nominal life must be corrected. See values for the correction factor in **table 1**. For example, if a reliability of 98% is required,  $L_2 = 0,33 L_{10}$  where  $L_{10}$  is calculated using the formulae in **pages 44 to 50**.

Table 1

Correction factor for reliability		
Reliability [%]	Correction factor	$L_n$
90	1,00	$L_{10}$
95	0,62	$L_5$
96	0,53	$L_4$
97	0,44	$L_3$
98	0,33	$L_2$
99	0,21	$L_1$

## Service life

The actual life achieved by a specific roller screw is known as service life. In addition to material fatigue, service life can be reduced by inadequate lubrication, wear, corrosion, contamination and, more generally, loss of the functional characteristics required by the application.

Experience with similar applications will help in selecting the right screw to obtain the desired service life. Structural requirements such as the strength of screw ends and nut attachments should also be considered.

To attain  $L_{10}$  life performance, the maximum cycle operating load  $F_{max}$  should not exceed 80% of  $C_a$  (for SR and SV product assortments) to limit the Hertzian pressure at the rollers/raceways contact points. If  $F_{max}$  exceeds 50% of the  $C_a$  value, please contact your SMT representative for validation.

For small strokes (shorter than the nut length) or short oscillations, additional considerations such as the actual total number of loading cycles on any specific area of the shaft, and the false brinelling effect should be taken into account<sup>1)</sup>.

## Equivalent dynamic load $F_m$

The loads acting on the screw can be calculated according to the laws of mechanics if the external forces are known or can be calculated. For product sizing and selection, it is necessary to calculate the equivalent dynamic load: this is the hypothetical load, constant in magnitude and direction, acting axially and centrally on the screw, which, if applied, would have the same influence on the screw life as the actual loading conditions which the screw will be subjected to.

Radial and moment loads must be accommodated by linear guides. It is extremely important to resolve these possible problems early in the design stage. Radial forces are detrimental to the life and expected performance of the screw (→ fig. 2).

Please refer to the chapter entitled Recommendations for assembly.

If misalignment, uneven loading, shock loads, etc. cannot be avoided, they must be taken into account during the sizing of the screw. Their influence on the screw's nominal life can generally be estimated<sup>1)</sup>.

<sup>1)</sup> For additional information, please contact your local Ewellix representative

## Basic static load carrying capacity $C_{0a}$

Roller screws should be selected based on the basic static load carrying capacity  $C_{0a}$ , rather than the basic dynamic load carrying capacity, when they are subjected to continuous or intermittent shock loads while operating in stationary conditions for short periods of time.

The permissible load is determined by the permanent deformation caused by the load acting at the contact points. The static load carrying capacity is, according to ISO standards, the purely axially and centrally applied static load which creates, by calculation, a total (rolling element + threaded surface) permanent deformation equal to  $1/10\,000$  of the curvature diameter of the rolling element.

In order to prevent surface damage, to keep smooth running and low noise level, Ewellix recommends that the application loads do not exceed 80% of the static load carrying capacity  $C_{0a}$ , which equals to a static safety factor  $s_0$  of 1,25.

Usually the  $C_{0a}$  value corresponds to a Hertzian contact pressure ranging between 4 500 and 4 800 MPa.

Fig. 2

Permissible and prohibited loading on roller screw

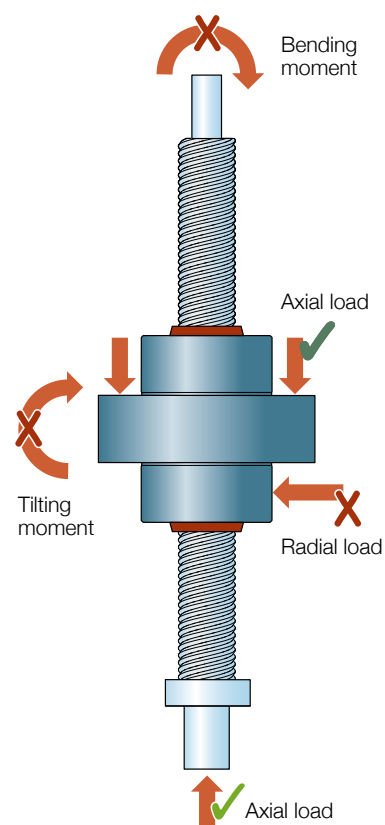

The basic dynamic and static load carrying capacities are related to the material properties, and vary with the material hardness at the contact points. Please refer to the paragraph explaining “materials, heat treatment and coatings” (↳ page 26).

The basic static load carrying capacity must be, at a minimum, equal to the product of the maximum applied axial static load and a static safety factor  $s_0$ . Past experience with similar applications and requirements of maximum static load occurrence, running smoothness and noise level will guide the selection of  $s_0$ <sup>1)</sup>.

For applications requiring high precision, roller screws should operate significantly below the static load carrying capacity, which means operation with a higher value for the static safety factor  $s_0$ .

For heavily loaded applications where precision, noise level and running smoothness are not critical to the performance expectations, roller screws can operate at load levels close to the basic static load carrying capacity. With these conditions, special care must be paid to proper lubrication.

## Critical rotating speed for screw shafts $n_{cr}$

A roller screw with the nut in a given position has a natural frequency of vibration in bending mode. When the screw shaft is rotating, it is important that the rotational speed not excite its natural frequency. If it does, it would result in elastic radial deflection of the shaft. In extreme conditions, without damping, the screw shaft could be bent. The natural frequency of the roller screw changes continuously as the nut moves along the shaft and in relation to the shaft supports. The positive effect of this axial nut displacement is that there is generally no time for the amplitude of the vibration at a given natural frequency to build up.

For calculation of the critical rotating speed, the shaft is the equivalent of a cylinder with an external diameter equal to the root diameter of the thread. The formula uses a parameter whose value is dictated by the mounting of the screw shaft ends, whether the screw shaft end is free, radially supported or fixed.

As a general rule, the nut is not considered to be a support for the screw shaft. Because of the potential inaccuracies in the mounting of the screw assembly, a safety factor of 0,8 is applied to the calculated critical speed.

<sup>1)</sup> For additional information, please contact your local Ewellix representative

Calculations where the nut is considered to be a support for the shaft or calculations which reduce the safety factor, require practical tests and possibly optimization of the design.

## Permissible speed limit ( $n_{d_0}$ ) and acceleration

The permissible speed limit is the speed that a screw cannot reliably exceed at any time. It corresponds to the limiting speed of the rotation of rollers (SR and ISR types) or of the recirculation of the rollers (SV type) inside the nut. It is expressed as the product of maximum rotational speed  $n$  (r/min) and the nominal diameter  $d_0$  (mm) of the screw shaft. The speed limits quoted in this catalogue are the maximum speeds that may be applied for short periods of time with optimized conditions of alignment, light external load or preload, and with appropriate lubrication.

Permissible speed limits for each technology:

- Planetary roller screw (SR) and inverted roller screw (ISR):  
 $n_{d_0} \leq 160\,000$
- Recirculating roller screw (SV):  
 $n_{d_1} \leq 30\,000$  for  $d_1 \leq 25$  mm  
 $n_{d_1} \leq 20\,000$  for  $d_1 > 25$  mm

Running a screw continuously at the permissible speed limit may reduce the service life of the nut mechanism.

### Important:

High speeds combined with high loads yield a relatively short nominal life<sup>1)</sup>.

In the case of high accelerations, decelerations or fast movement reversal, Ewellix recommends either working under a nominal external load or applying a light preload to the nut to avoid roller sliding on the shaft.

The preload for screws subjected to high accelerations must be calculated to be sure that the rolling elements do not slide<sup>1)</sup>.

However, excessive preload will generate an unacceptable increase in frictional heat.

Roller screws preloaded for optimum rigidity (PR or PV prefix) should not be operated continuously at high speeds.

Recirculating roller screws should not be operated at permanent high linear speeds or at their maximum speed rating. High speeds will be detrimental to the recirculation cam's life. In addition, noise levels will increase.

# Efficiency $\eta$

Screw performance depends primarily on the geometry of the contact surfaces, their finish and the helix angle of the thread.

It also depends on the working conditions (load, speed, lubrication, preload, alignment, etc.)

Direct efficiency  $\eta$  is used to define the input torque required to transform the rotation of one component into the translation of another (→ **diagram 2**).

Conversely, indirect efficiency  $\eta'$  is used to define the axial load required to transform the translation of one component into the rotation of another one. It is also used to define the braking torque required to prevent that rotation (→ **diagram 3**).

The reference coefficient of friction  $\mu_{ref}$  would be achievable with perfect operating conditions of lubrication, alignment, etc. and it would result in generating a theoretical direct efficiency  $\eta$ , or a theoretical indirect efficiency  $\eta'$ . Because such laboratory conditions are not encountered with real applications, we define a practical coefficient of friction  $\mu_{prac}$  used to estimate the practical efficiencies  $\eta_p$  and  $\eta'_p$ .

Practical efficiencies range between the starting efficiencies of a newly installed screw and that of a properly run-in screw. These practical values of efficiency are calculated with a practical value for the coefficient of friction  $\mu_{prac}$ .

To account for real installation, running conditions and the experience of real life application, this practical coefficient of friction  $\mu_{prac}$  corresponds to the reference coefficient of friction  $\mu_{ref}$  increased by 30% (→ **diagram 1**).

This calculation method reduces the practical efficiency of the screw versus its theoretical efficiency by about 5%.

Generally, the practical efficiency increases with speed, and over time with running in effect.

**Note:**

The helix angle  $\alpha$  can be calculated using formula **page 45**.

Diagram 1

Reference and practical coefficient of friction

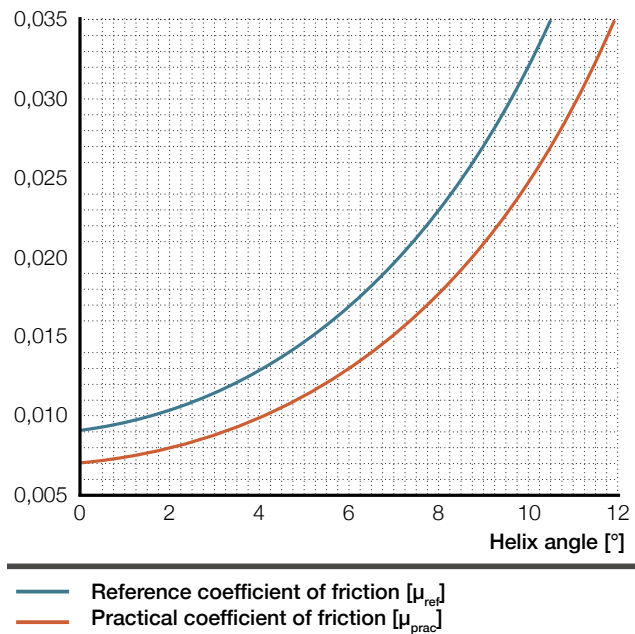

Diagram 2

Theoretical and practical direct efficiency

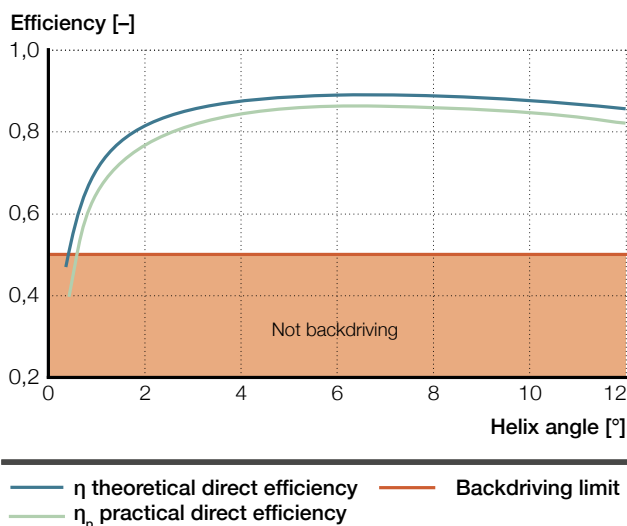
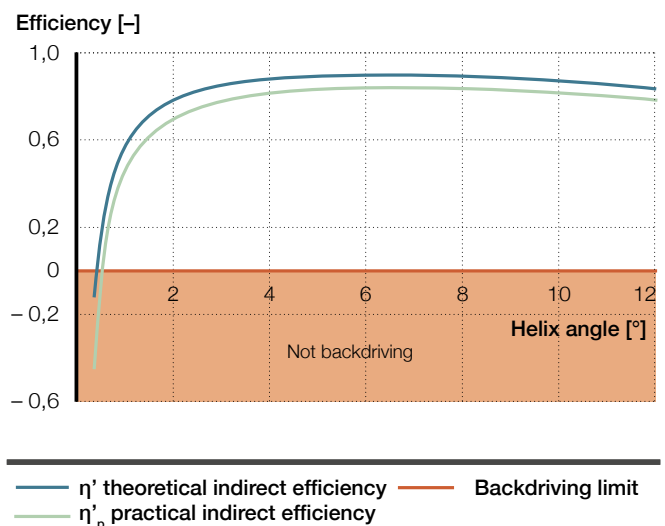

Diagram 3

Theoretical and practical indirect efficiency



## Back-driving and braking torque $T_b$

Except for one specific recirculating roller screw dimension (SV 50x1) and for some specific sizes of inverted roller screws, roller screws are reversible or can be back-driven under most circumstances.

A braking mechanism (gear reducer or brake) must be part of the design if back-driving is to be avoided.

If back-driving is required, special care must be taken to align the whole system. Misalignment significantly increases the coefficient of friction by tilting and, consequently, increases the axial force required to back-drive the mechanism.

### Attention:

Vertical installations and applications presenting a risk of falling loads require special care by designers and users. It is the customer's responsibility to determine the need for back-up locking devices and safety systems.

## Break away torque $T_x$

This is the amount of torque required to overcome the following forces to start rotation:

- **(a)** The total inertia of all moving parts accelerated by the source of power (including rotational and linear movements)
- **(b)** The internal friction of the screw/nut assembly, bearings and associated guidance systems.

In general, the torque required to overcome inertia **(a)** is greater than the friction torque **(b)**. The coefficient of friction  $\mu_s$  for a high-efficiency screw, when it starts moving, is estimated to reach up to twice the amount of the practical dynamic coefficient of friction  $\mu_{prac}$ , under normal operating conditions.

## Driving torque $T_t$

- This is the total torque required from the electric motor to overcome inertia, external forces, preload, friction, etc. Please see calculation formulae on **pages 44 to 50**.

## Static axial stiffness $R_t$

The static axial stiffness of a complete roller screw assembly is the ratio of the external axial load applied to the system and the axial displacement of the face of the nut in relation to the fixed (anchored) end of the screw shaft. The inverse of the system's overall stiffness is equal to the sum of all inverted values of stiffness for each component (screw shaft, roller nut, support bearings, etc.)

Therefore, the overall stiffness of the system is always lower than the lowest value for stiffness of any individual component.

### Nut stiffness $R_n$

When a preload is applied to a nut, the internal play is eliminated. Additionally, the squeeze load responsible for generating the preload creates initial Hertzian elastic deformation at the contact points. This leads to an increase in stiffness proportionate to the preload value.

The theoretical elastic deformation at the contact points does not take into account machining inaccuracies, actual sharing of the load between the different contact surfaces, or elasticity of the nut and screw shaft.

For this reason, two stiffness values are given in the catalogue:

- **$R_{ng}$** : This is the minimum nominal stiffness reached by any nut and roller assembly. This value, based on laboratory measurements, is a practical value and does not require any correction factor. It takes into account production tolerances, actual load sharing, preload torque tolerance, deflection of the nut body, etc. It can be used to calculate the total stiffness during the roller screw selection process.
- **$R_{nr}$** : This value corresponds to the reference nominal stiffness of a nut and roller assembly with all geometrical dimensions centered within the tolerances. It corresponds to the optimum stiffness level.

$R_{nr}$  is always greater than  $R_{ng}$ . Both values are determined by applying an external axial load, centered on the screw shaft and equal to twice the preload force.

### Shaft stiffness $R_s$

The elastic deformation of the screw shaft is proportional to its length and inversely proportional to the square of its root diameter.

According to the relatively low stiffness of the shaft, an increase of the nut preload (and its stiffness) will, in most cases, not increase significantly the overall stiffness of the system.

Consequently, the preload stated in the catalogue for each screw dimension is the maximum and should not be exceeded.

# Materials, heat treatment and coatings

## Choice of steel material

Standard screw shafts are mainly manufactured from pre-treated 50CrMo4 (otherwise 42CrMo4) which is surface hardened by induction. Through hardened 100Cr6 bearing steel is used for nuts and rollers.

100Cr6 can also be selected for the screw shaft for operation at higher temperature up to 180 °C, or if the application presents a concern for wear.

Material properties are detailed in **table 3**.

Stainless steel can be used for all types of roller screws. Properties offered by these special steel variants are summarized in **table 2**.

Table 2

Selection of stainless steels			
Steel (ISO standard)	Description	Shaft hardness [HRC]	Relative corrosion resistance
X105CrMo17	Martensitic stainless steel	58–60	**
X30Cr13	Martensitic stainless steel	50–55	***
X12CrNiMoV12–3	Carburizing stainless steel	58–60	***
X40CrMoVN16–2	Nitrogen stainless steel	58–60	****
X5CrNiCuNb16–4	Precipitation hardening stainless steel	38–45	*****
X5CrNiCuNb16–4	Martensitic stainless steel	40–45	*****

Table 3

Selection of standard steels							
Component	Steel	Supplying state	Heat treatment	Maximum allowed operating temperature	Surface hardness at standard tempering temperature [HRC ]	Customer benefits	
Standard shaft	50CrMo4 or 42CrMo4	Pre-treated	Tensile strength 880 to 1 030 MPa Yield strength > 650 MPa	Induction hardening	110 °C	58 to 60	Good wear resistance Resilience
Standard shaft on request	50CrMo4	Pre-treated	Tensile strength 880 to 1 030 MPa Yield strength > 650 MPa	Induction hardening Higher tempering temperature	150 °C	58 to 60	Good wear resistance and medium temperature operation Resilience
Special shaft	100Cr6	Pre-treated	Tensile strength 840 to 970 MPa Yield strength > 500 MPa	Induction hardening	180 °C	59 to 63	Higher wear resistance, adapted to higher operating temperature but more brittle
Nut & rollers	100Cr6	Annealed		Through hardening	180 °C	58 to 62	Good wear resistance and high temperature operation

## Effect of surface hardness on roller screw basic load rating

According to the ISO reference calculations, the load ratings provided in the catalogue are given for surface hardness above 654 HV (58 HRC). For materials or treatments resulting in a lower hardness, correction factors should be applied to the dynamic and static load carrying capacities:

$$C_{a \text{ corrected}} = C_a \left( \frac{HV_{\text{actual}}}{654} \right)^2$$

$$C_{0a \text{ corrected}} = C_{0a} \left( \frac{HV_{\text{actual}}}{654} \right)^2$$

### Note:

654 HV is equivalent to 58 HRC

## Surface coatings

Ewellix offers various types of surface coatings for improved roller screw performances:

- Manganese phosphate coating of carbon steels to improve corrosion resistance
- Low friction coating is available on request<sup>1)</sup>.

## Operating temperature

Operating at high temperatures will lower the steel hardness, alter the thread accuracy, may increase the oxidation of the materials and change the lubricant properties.

With operating temperature lower than  $-20\text{ }^{\circ}\text{C}$ , the core resilience of the material can become critical. The lower the temperature, the more brittle the material becomes, especially with a long or thin screw shaft. Bending stresses or shock loads increase the risk of fractures.



Through hardening treatment

<sup>1)</sup> For additional information, please contact your local Ewellix representative

Applications with high cycling rates and high loads can generate excessive amounts of heat. To eliminate excess heat, Ewellix can provide a nut mechanism, with cooling chambers. When connected to a customer supplied water circulation system, temperatures can be stabilized, enabling higher cycling rates and increased productivity.

## Screw shaft buckling or column strength $F_c$

The column loading of a screw shaft must be checked when it is subjected to dynamic or static compression loading.

The maximum permissible compressive load is calculated using the Euler formulae, with a safety factor of 3 to 5, depending on the application. The type of shaft end mounting is critical for selecting the proper coefficient to be used in the Euler formulae.

When the screw shaft has a single diameter along its total length, the root diameter of the threaded shaft is used for the calculation. When the screw shaft comprises different sections with varying diameters, calculation becomes more complex<sup>1)</sup>.

# Shaft design

It is possible to deliver screws with one end larger than the shaft outside diameter  $d_1$ . This design feature is frequently used in conjunction with support bearings with large bore diameter.

To grind the thread efficiently, an undercut with root diameter  $d_2$  and length  $l_2$  is needed (→ fig. 3 and table 4).

## Designing the screw shaft ends

Customers designing their screw shaft ends are responsible for checking their strength against static and dynamic operating conditions.

The simple approach considers the shaft end diameters. Stress concentration factors must be used.

Zone A must be checked for strength against torsion and zone B must be checked for strength against torsion and tension (→ fig. 4).

### Important:

Application loads reaching the basic load rating  $C_a$  generate very high mechanical stresses on the shaft ends. Ewellix strongly recommends that shaft ends be calculated with extreme care for such applications.

Table 4

Type of roller screw	Design conditions	Value for $l_2$
SR, BR, PR, HR, SRR	$d_3 \leq 1,85 d_1$ Lead $P_h \leq 8$ mm	$l_2 \geq 12$ mm
	$d_3 \leq 1,85 d_1$ Lead $P_h > 8$ mm	$l_2 \geq 1,4 P_h$
SV, BV, PV	$d_3 \leq 1,85 d_1$ Lead $P_h = 1$ mm	$l_2 \geq 12$ mm
	$d_3 \leq 1,85 d_1$ Sizes $d_0 P_h = 40 \times 2$ or $50 \times 2$ or $63 \times 2$ mm	$l_2 \geq 12$ mm
	$d_3 \leq 1,85 d_1$ All other types of recirculating roller screws	$l_2 \geq 14$ mm
<b>All types of roller screws</b>	$d_3 > 1,85 d_1$	Please contact your local Ewellix representative

Fig. 3

Shaft design with shoulder

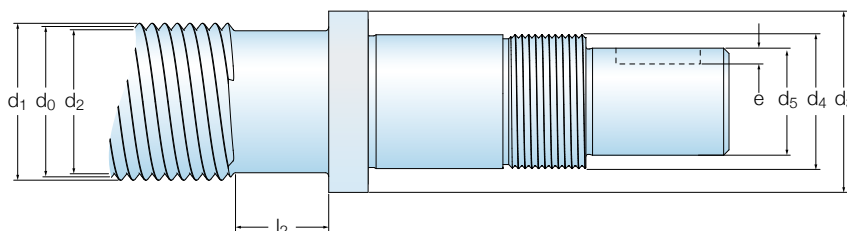
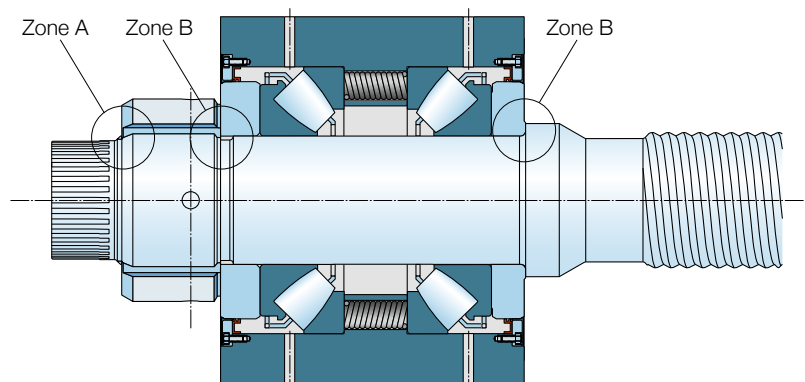

Fig. 4

Shaft end with support bearing



## Zone A: Torsion only

The nominal shear stress  $\tau$  caused by the input torque  $T$  is given by:

$$\tau = \frac{16\,000\,T}{\pi d_5^3}$$

This value is increased by a stress concentration factor  $f_4$  to give the real shear stress  $\tau_p$

$$\tau_p = f_4 \tau$$

According to von Mises, the total stress  $\sigma_t$

$$\sigma_t = 1,73 \tau_p$$

For safety,  $\sigma_t$  should be less than 67% of the yield strength.

If the end diameter  $d_5$  includes a key-way of depth  $e$ , calculate using  $(d_5 - e)$  instead of  $d_5$ .

The angle of twist of the screw shaft is given by

$$\Theta = \frac{7,48\,Tl}{d_0^4}$$

where

$l$  = length between motor and nut

The linear positioning error,  $\delta$ , caused by this twist is

$$\delta = \frac{P_n \Theta}{360}$$

### Note:

Stress concentration factors  $f_4$  and  $f_5$  are available in all general mechanical literature.

### Units:

$d$ : mm

$\tau$ : N/mm<sup>2</sup> [MPa]

$\sigma$ : N/mm<sup>2</sup> [MPa]

$\Theta$ : degree [°]

$\delta$ : mm

$F$ : N

## Zone B: Axial + torsional stresses

The nominal axial stress caused by the axial load  $F$  is given by

$$\sigma = \frac{4\,F}{\pi d_4^2}$$

This value is increased by a stress concentration factor  $f_5$  to give the real principal stress  $\sigma_p$

$$\sigma_p = f_5 \sigma$$

As for zone A calculation

$$\tau_p = f_4 \tau$$

According to von Mises, the total stress  $\sigma_t$

$$\sigma_t = (\sigma_p^2 + 3 \tau_p^2)^{1/2}$$

For safety,  $\sigma_t$  should be less than 67% of the yield strength.

## Product inspection and certification

Standard or special inspection reports or certificates can be provided on request. The following reports can be supplied with roller screws:

1. Conformity with customer specifications (fl. EN 10204)
2. Conformity with catalogue specifications (fl. EN 10204)
3. List of manufacturing and control operations
4. Preload torque curve or internal friction torque curve
5. Lead precision curve
6. Matching of travel deviation
7. Stiffness curve
8. Raw material chemical analysis
9. Magnetic particle inspection
10. Through hardening heat treatment
11. Induction hardening
12. Carburizing hardening
13. Surface treatment
14. Report for specific dimensions
15. FAIR (First Article Inspection Report) EN9102

## Working environment

As a stand-alone component, the roller screws cannot be ATEX certified.

Use of roller screws for an application in a potentially explosive environment shall be related to a technical file deposit according to european directives relative to ATEX.

# Axial play and preload

## Axial play and preload

Standard roller screws are manufactured with axial play which varies between 0,02 mm and a maximum of 0,1 mm, depending on product size.

Roller screws can be manufactured without backlash or with preload (↳ **table 8**).

For optimum stiffness and positioning accuracy during reversal of loading direction, or during operation with low external load, internally preloaded nuts are recommended. Under these conditions, preloaded nuts exhibit a much lower axial deflection and much higher stiffness than non-preloaded nuts.

All preloaded roller screws (PR and PV types) are run in before delivery to the customer. This process stabilizes preload and stiffness and virtually eliminates backlash over the service life of the screw.

## Preload and stiffness

Typical load/deflection curves for four different nut designs are shown in **diagram 10**:

- Curve #1: Single nut with axial play
- Curve #2: Single nut without backlash
- Curve #3: Preloaded split nut
- Curve #4: Preloaded double nut

Table 8

Nut type Prefix	Internal nut design
SR	Planetary roller screw with axial play
BR	Planetary roller screw without backlash
PR	Planetary roller screw with preloaded split nut
PRM	Planetary roller screw with preloaded double nut
SV	Recirculating roller screw with axial play
BV	Recirculating roller screw without backlash
PV	Recirculating roller screw with preloaded split nut
PVM	Recirculating roller screw with preloaded double nut

Diagram 10

Load/deflexion curve for different nut types

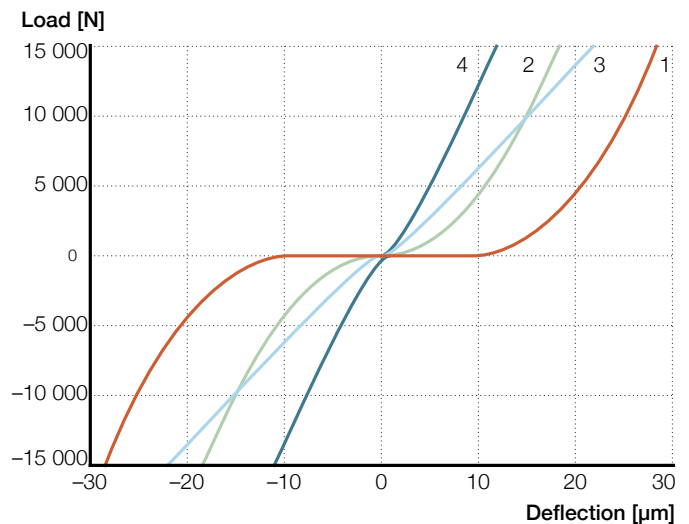

The effect of the internal preload in a split nut is shown in **figure 6**. A squeeze load  $F_q$  is applied to the two halves of a split nut. With a precisely ground and calibrated spacer, this squeeze load  $F_q$  generates the internal preload force  $F_{pr}$ .

The application of an external load  $F$  on a preloaded split nut results in different load values on each half of the nut (→ **fig. 7**).

The relative load distribution on the two halves of the preloaded split nut can be described by the **figure 8**:

- At point A: without external load  $F$ , the two nut halves are in equilibrium under preload  $F_{pr}$  (→ **fig. 6**)
- At point B: with external load  $F$  applied to nut half #2 (→ **fig. 7**), the axial force taken by nut half #2 increases to value  $F_2$ , and the preload of nut half #1 is reduced to value  $F_1$ . For all situations where  $F \leq 2,83 F_{pr}$ , the load seen by nut half #2 is greater than the external load. Therefore, increasing the preload would reduce the life of the screw
- At point C, where external load  $F = 2,83 F_{pr}$ , the axial load taken by nut half #2 is equal to  $F$ . At this point, nut half #1 becomes unloaded
- At point D, with  $F = 2,83 F_{pr}$  applied to nut half #1, nut half #2 becomes unloaded.

For a given system, the level of the preload force  $F_{pr}$  corresponds to a few percentage points of its dynamic load carrying capacity  $C_a$ .

With a preloaded split nut design, the external load is taken by one of the two nut halves for a given external load direction. Under high loads, the load carrying capacity and maximum stiffness level of a preloaded split nut are substantially lower than for a one-piece nut. Under low load conditions, a preloaded split nut eliminates backlash and increases the degree of stiffness.

Fig. 6 Preload in a split nut without external load

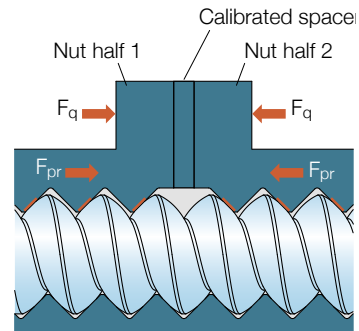
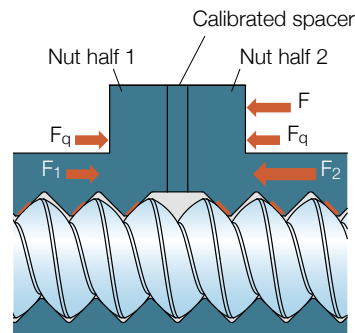

Fig. 7 Preloaded split nut with external force



Running in bench



Preload torque test bench



Fig. 8 Concept of preloaded nut

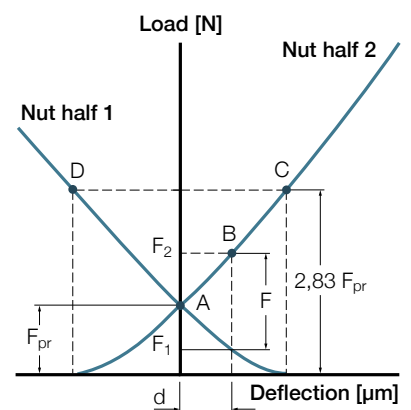

Because of the very high load capacity and stiffness of roller screws, a split nut usually offers sufficient capacity for most applications and offers an extremely compact design.

In exceptional cases where the load rating of a preloaded split nut is not sufficient, two single nuts may be preloaded together (↳ **fig. 9**). Exact dimensions are available on request by contacting Ewellix.

## Preload torque $T_{pr}$

Preload torque  $T_{pr}$  is the friction torque resulting from the sole preload force  $F_{pr}$ , and is calculated considering the practical efficiency of the selected screw (see calculation formulae **pages 44 to 50**).

## Preload torque tolerances

For preloaded roller screws, an optimum preload torque  $T_{pr}$  has been calculated and is provided in the product tables.

These values correspond to a compromise between the stiffness level and the preload force applied. A higher preload torque would penalize the driving torque, potentially decrease the product life and could generate additional heat, whereas a lower preload torque would decrease the level of stiffness. For specific cases where a different preload torque is required, please contact your local Ewellix representative.

The variation tolerance of preload torque along a screw shaft depends on:

- The helix angle of the screw thread
- The slenderness of the screw shaft (i.e. the ratio  $l_1/d_0$  of threaded length over nominal diameter)
- The lead precision
- The preload torque range.

**Tables 9 and 10** give the tolerances for preload torque variation, with screw thread helix angle less than  $11^\circ$ , and greater than  $11^\circ$  respectively.

Preload torque is measured at 50 r/min with ISO 68 oil grade for BR and PR screw types and with ISO 220 oil grade for BV and PV screw types.

### Note:

The helix angle  $\alpha$  can be calculated using formulae in **page 45**.

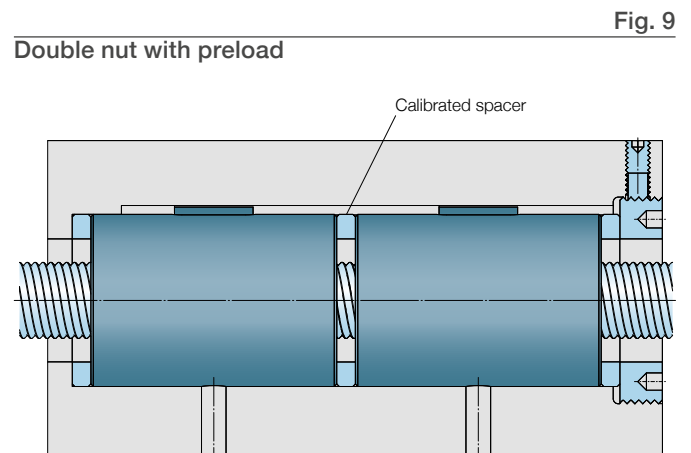

**Example:**

Screw PRU 39 x 5R 433/780 G3 WPR has been selected.

According to the information in the product tables, the preload torque is  $T_{pr} = 1,3 \text{ Nm}$ . What is the tolerance of preload torque for G3 lead precision?

The helix angle is  $2,34^\circ$  and the threaded length is 433 mm ( $l_1/d_0 = 11,1 < 40$ ).

**Table 9** gives a variation tolerance of  $\pm 20\%$  for G3. All screws will exhibit a friction torque of  $1,3 \text{ Nm} \pm 20\%$  or 1,04 to 1,56 Nm.

The corresponding minimum nominal nut stiffness is  $R_{ng} = 750 \text{ N}/\mu\text{m}$ , and the nominal reference nut stiffness is  $R_{nr} = 980 \text{ N}/\mu\text{m}$ .

**Diagram 11** presents the above calculated ranges and a typical torque variation measurement. Preload torque or internal friction torque certificates can be supplied on request.

Table 9

Tolerance of preload torque for screws with $\alpha < 11^\circ$							
$T_{pr}$ over Nm	incl.	G1 $l_1/d_0 \leq 40$ and $l_1 \leq 4\ 000$ $\pm\%$	G3	G5	G1 $40 < l_1/d_0 \leq 60$ and $l_1 \leq 4\ 000$	G3	G5
0	0,2	35	40	50	40	50	60
0,2	0,6	25	30	35	30	35	40
0,6	1,0	20	25	30	25	30	35
1,0	2,5	15	20	25	20	25	30
2,5	6,3	10	15	20	15	20	25
6,3	10,0	10	10	15	15	15	20

Table 10

Tolerance of preload torque for screws with $\alpha \geq 11^\circ$					
$T_{pr}$ over Nm	incl.	G3 $l_1 \leq 2\ 000$ $\pm\%$	G5	G3 $2\ 000 < l_1 \leq 4\ 000$	G5
0	10,0	70	80	80	90

Planetary roller screws preloaded for optimum stiffness with  $\alpha \geq 11^\circ$  are not available with G1 lead precision

Diagram 11

Preload torque measurement graph

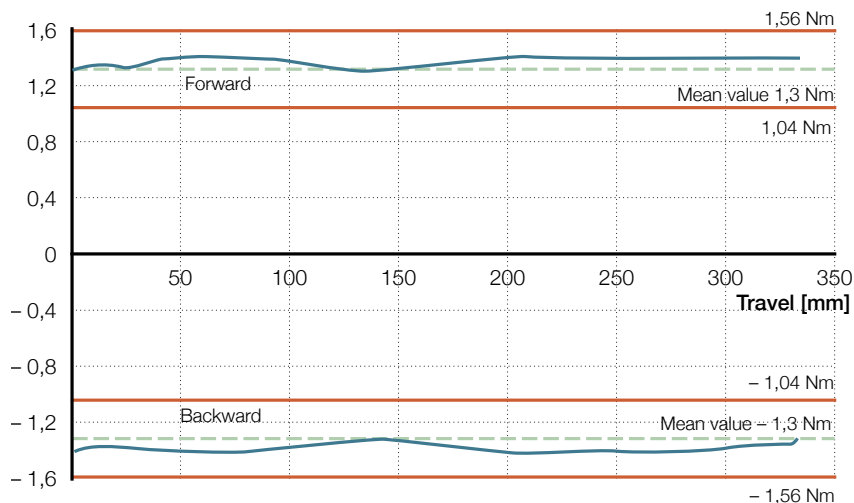

— Example of measurement record for a PRU 39 x 5R 433/780 G3 WPR

# Preload adjustment

## Cylindrical nuts

For cylindrical nuts with preload, the stoppers threaded into the housing must be tightened according to the torque values listed in **table 11** for PRU planetary roller screws (↳ **fig. 12**), and in **table 12** for PVU recirculating roller screws (↳ **fig. 13**).

Note that torque values in **tables 11** and **12** also apply to single piece nuts such as SRC/BRC (↳ **fig. 10**) and SVC/BVC (↳ **fig. 11**) nut types respectively.

Standard nuts are made of bearing steel hardened to 58 to 62 HRC. Under certain load conditions, it is necessary to use hardened and ground spacers to avoid imbedding the nut side face into the housing shoulder and into the stopper clamping area. This precautionary measure will diminish the risk that preload and stiffness are reduced.

## Flanged nuts

For flanged nuts with preload, the fixing bolts must be tightened according to the torque values listed in **table 13** for PRK planetary roller screws and PVK recirculating roller screws. (↳ **fig. 14**).

Fig. 10

SRC/BRC

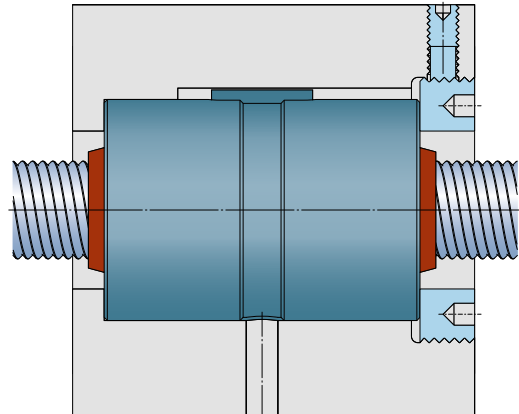

Fig. 12

PRU

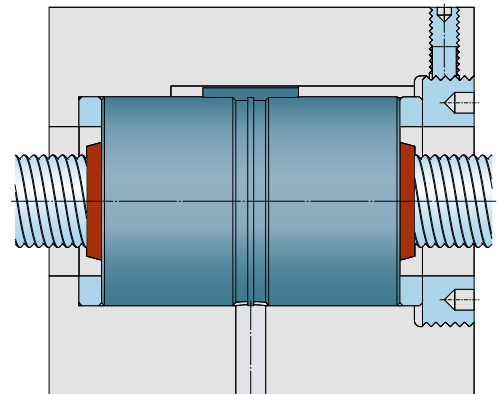

Fig. 11

SVC/BVC

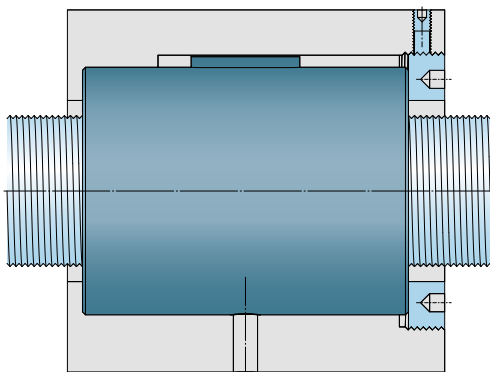

Fig. 14

PRK/PVK

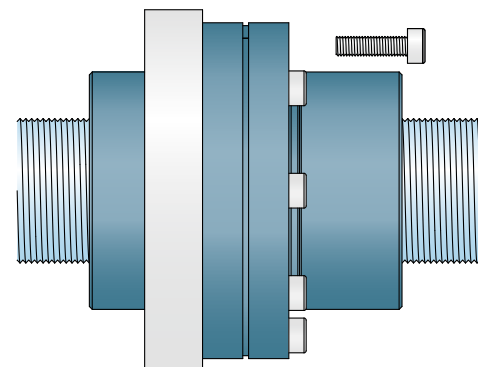

Fig. 13

PVU

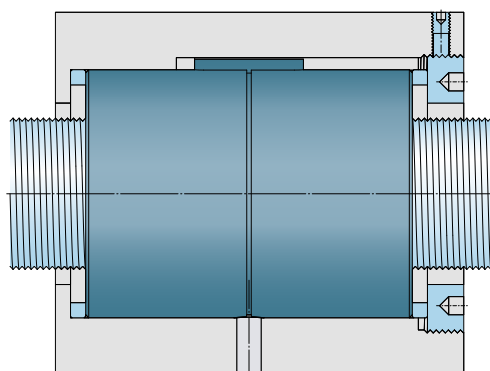

Table 11

SRC/BRC/PRU

Nominal diameter $d_0$ mm	Housing stopper thread	Tightening torque Nm	Squeeze load N
8	30 M1,0	20	2 700
12	35 M1,0	35	4 100
15	40 M1,0	45	4 600
21	50 M1,0	65	5 500
25	60 M1,0	80	5 500
30	70 M1,5	100	5 900
39	90 M1,5	140	6 400
44	88 M1,5	160	7 600
48	110 M1,5	180	6 800
60	130 M2,0	230	7 400
64	125 M2,0	250	8 300
75	158 M2,0	310	8 200
80	148 M2,0	340	9 600
99	215 M2,5	440	8 500
120	230 M2,5	550	9 950
150	340 M2,5	730	8 950

Table 12

SVC/BVC/PVU

Nominal diameter $d_1$ mm	Housing stopper thread	Tightening torque Nm	Squeeze load N
8	25 M1,0	20	3 250
10	27 M1,0	27	4 000
12	30 M1,0	35	4 800
16	35 M1,0	48	5 600
20	40 M1,0	62	6 400
25	47 M1,0	82	7 200
32	60 M1,0	110	7 600
40	75 M1,5	145	8 000
50	87 M1,5	300	9 000
63	108 M2,0	300	9 600
80	146 M2,0	335	9 500
100	185 M2,5	440	9 900
125	230 M2,5	580	10 000

Table 13

PRK/PVK

Nominal diameter $d_0$ mm	Number of screws	Screw size	Tightening torque Nm
8	6	M4	3
10	6	M4	3
12	6	M4	3
15	6	M5	6
16	6	M4	3
20	6	M5	6
21	6	M5	6
25 (PRK)	6	M6	10
25 (PVK)	6	M5	6
30	6	M8	25
32	6	M6	10
36	6	M8	25
39	6	M10	50
40	6	M8	25
44	6	M10	50
48	6	M12	80
50	6	M10	50
56	6	M12	80
60	6	M16	200
63	6	M12	80
64	6	M16	200
80	8	M16	200
100	12	M16	200
125	12	M18	270

# Lead precision and manufacturing tolerances

## Lead precision

Generally speaking, the precision indicated defines the lead precision class that complies with ISO 3408-3, e.g. G1, G3 and G5 (↳ **tables 14 and 15**).

Standard lead precision is G5. On request, Ewellix can deliver roller screws with G3 or G1 lead precision.

A roller screw lead precision class is primarily defined by the maximum permitted travel variation  $V_{300p}$  over a threaded length of 300 mm (↳ **table 14**).

Lead precision characteristics are defined by the permitted lead error  $e_p$ , and the permitted travel variation  $V_{up}$ , measured at 20 °C over the useful stroke  $l_u$  (↳ **tables 15, 16 and fig. 15**).

Some customer applications require a travel compensation  $c$  to account for the effect of operating temperature on the lead precision: a temperature variation by 1 °C results in dimensional change of 11,5  $\mu\text{m}/\text{m}$  of screw shaft length. Consequently, if needed, a travel compensation  $c$  can be achieved.

- Standard case with  $c = 0$  (↳ **fig. 16**)
- Case with customer specific value of  $c$  (↳ **fig. 17**)

Lead precision graphs can be supplied on request.

Table 14

Maximum permitted travel variation over 300 mm

G1 $V_{300p}$ $\mu\text{m}$	G3 $V_{300p}$	G5 $V_{300p}$
6	12	23

Table 15

Travel deviation and maximum permitted travel variation over the useful travel  $l_u$

$l_u$ over mm	incl.	G1		G3		G5	
		$e_p$ $\mu\text{m}$	$V_{up}$	$e_p$	$V_{up}$	$e_p$	$V_{up}$
<b>0</b>	<b>315</b>	6	6	12	12	23	23
<b>315</b>	<b>400</b>	7	6	13	12	25	25
<b>400</b>	<b>500</b>	8	7	15	13	27	26
<b>500</b>	<b>630</b>	9	7	16	14	32	29
<b>630</b>	<b>800</b>	10	8	18	16	36	31
<b>800</b>	<b>1 000</b>	11	9	21	17	40	34
<b>1 000</b>	<b>1 250</b>	13	10	24	19	47	39
<b>1 250</b>	<b>1 600</b>	15	11	29	22	55	44
<b>1 600</b>	<b>2 000</b>	18	13	35	25	65	51
<b>2 000</b>	<b>2 500</b>	22	15	41	29	78	59
<b>2 500</b>	<b>3 150</b>	26	17	50	34	96	69
<b>3 150</b>	<b>4 000</b>	32	21	62	41	115	82
<b>4 000</b>	<b>5 000</b>			76	49	140	99
<b>5 000</b>	<b>6 300</b>					170	119

Table 16

Useful travel

Type of roller screw	Useful travel $l_u = \text{threaded length} - 2 l_e$ where
Planetary roller screw	$l_e = 1 \times \text{lead}$
Recirculating roller screw	$l_e = 5 \times \text{lead}$



### Symbols used in figures

- $l_u$  useful travel
- $l_e$  excess travel (no lead precision required)
- $l_m$  actual mean travel (line which best fits the actual travel curve by method of least squares)
- $l_0$  nominal travel
- $l_s$  specified travel
- $c$  travel compensation (difference between  $l_s$  and  $l_0$  to be defined by the customer)
- $e_p$  permitted mean travel deviation (lead error) over the specified travel
- $e_a$  actual (measured) mean travel deviation over the specified travel
- $V$  travel variation (or permissible band width)
- $V_{300p}$  maximum permitted travel variation over 300 mm
- $V_{up}$  maximum permitted travel variation over the useful travel  $l_u$
- $V_{300a}$  measured travel variation over 300 mm
- $V_{ua}$  measured travel variation over  $l_u$
- $V_{2\pi p}$  maximum permitted travel variation within  $2\pi$  rad
- $V_{2\pi a}$  actual travel variation measured within  $2\pi$  rad

Definition of lead error measurement

Fig. 15

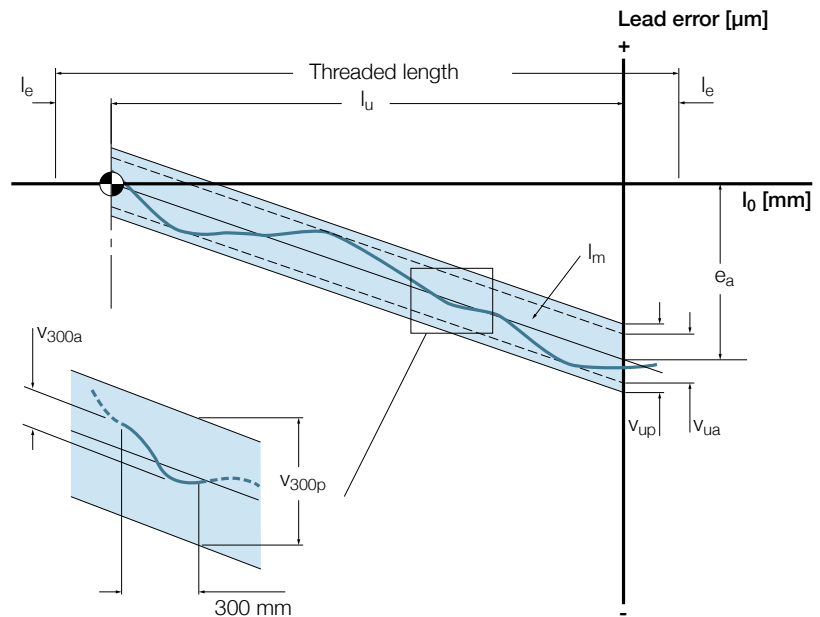

Fig. 16

Case without travel compensation

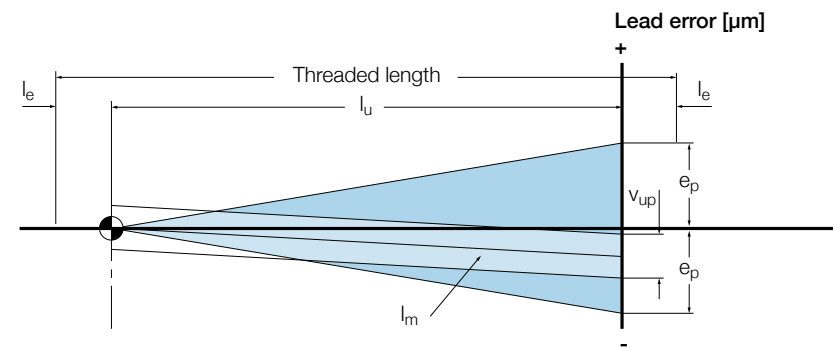
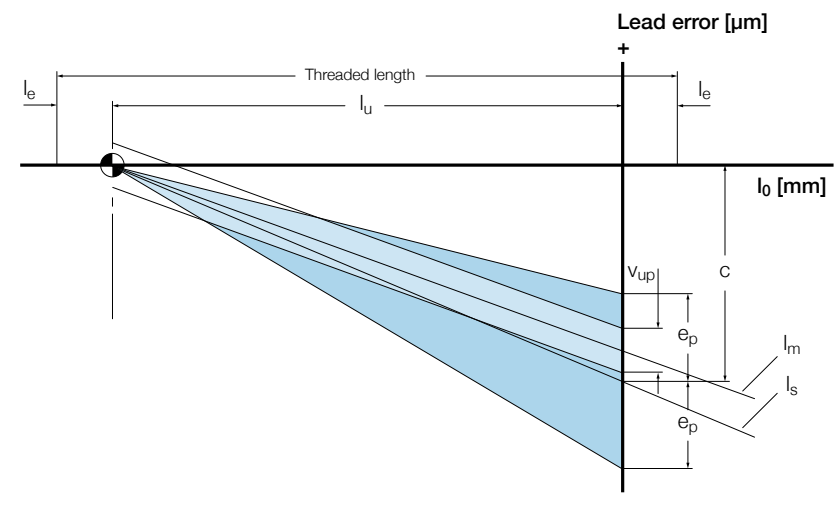

Fig. 17

Case with negative travel compensation



### Permissible travel variation $V_{2\pi p}$ within $2\pi$ rad (one revolution)

The maximum permissible travel variation  $V_{2\pi p}$  over one revolution can be an important parameter for some very high precision applications.

This lead precision parameter  $V_{2\pi p}$  is explained in **figure 18**. Values in accordance with ISO standards 3408-3 are provided in **table 17**.

On request, Ewellix can measure and provide the actual travel variation  $V_{2pa}$  over one revolution, for nominal screw diameters up to 40 mm and screw lengths up to 1 000 mm.

### Matching of travel deviation for screws working in parallel

When 2 or more screws are used together in parallel on one piece of equipment, it's often important to match their lead deviations.

A value M is defined as the maximum difference between the mean travel of any screw in a set. In cases where three or more screws are installed, M represents the maximum difference between the two most extreme mean travels of the set of screws (→ **table 18**).

**Figure 19, figure 20 and figure 21** represent 3 typical application examples.

Table 17

Maximum permitted travel variation within $2\pi$ rad	
Lead precision grade	$V_{2\pi p}$ μm
-	
G1	4
G3	6
G5	8

Table 18

Maximum mean travel deviation	
Numbers of screws in a set	M μm
2	$V_{up}$
> 2	$1,5 V_{up}$

Fig. 18

Travel deviation within  $2\pi$ rad

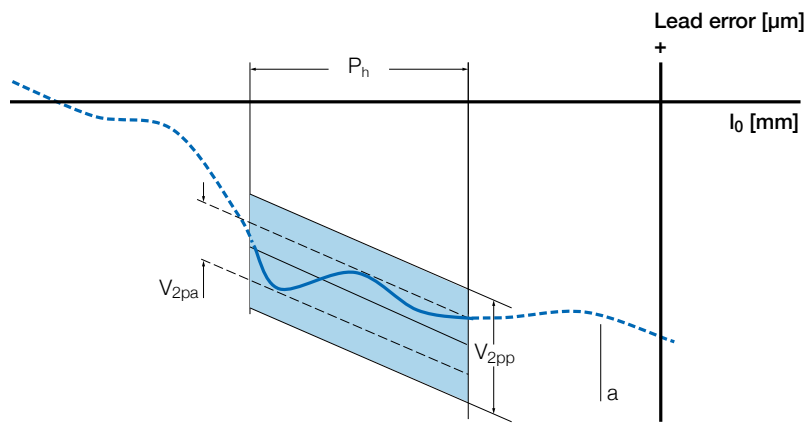

a is actual travel deviation

### Example 1

Two planetary roller screws of type SRC 25 x 5R 700/900 G3 Z WPR with lead precision G3 are working in parallel.

$$e_p = 18 \mu\text{m}$$

$$V_{up} = 16 \mu\text{m}$$

$$M = V_{up} = 16 \mu\text{m}$$

Example 1: Two matched screws

Fig. 19

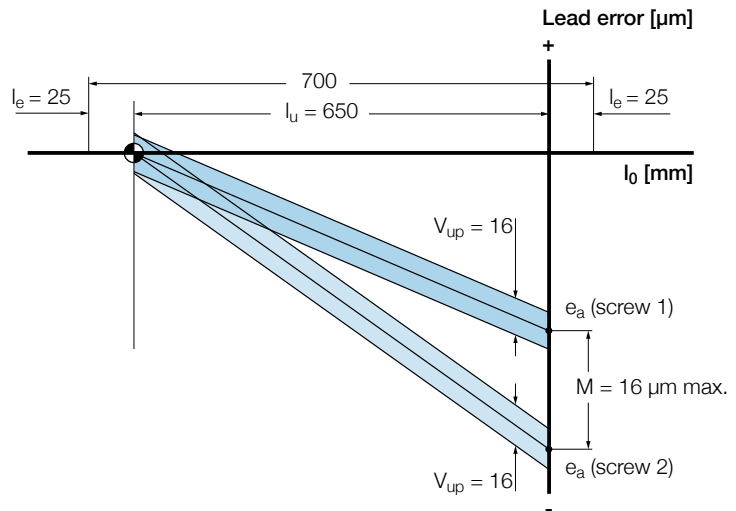

### Example 2

Two planetary roller screws of type SRC 25 x 5R 700/900 G3 Z WPR with lead precision G3 are working in parallel. The zero position is regulated at the middle position of the travel of the nut.

$$e_p = 18 \mu\text{m}$$

$$V_{up} = 16 \mu\text{m}$$

$$M = V_{up} / 2 = 8 \mu\text{m}$$

Example 2: Two matched screws with centered zero position

Fig. 20

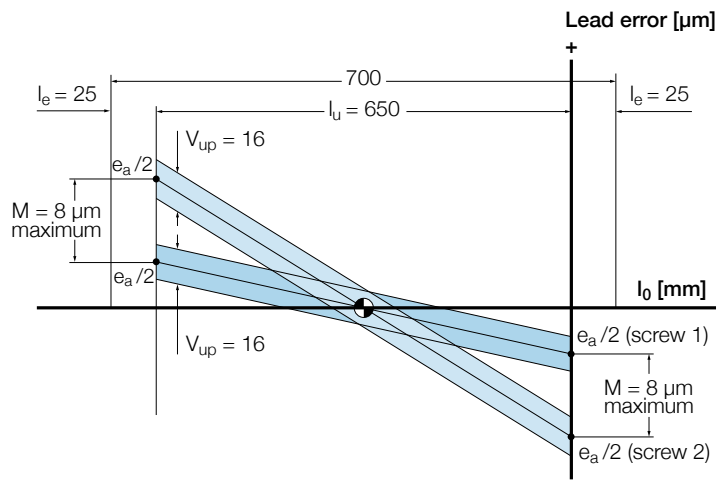

### Example 3

Four planetary roller screws of type SRC 25 x 5R 700/900 G3 Z WPR with lead precision G3 are working in parallel.

$$e_p = 18 \mu\text{m}$$

$$V_{up} = 16 \mu\text{m}$$

$$M = 1,5 V_{up} = 24 \mu\text{m}$$

Example 3: Four matched screws

Fig. 21

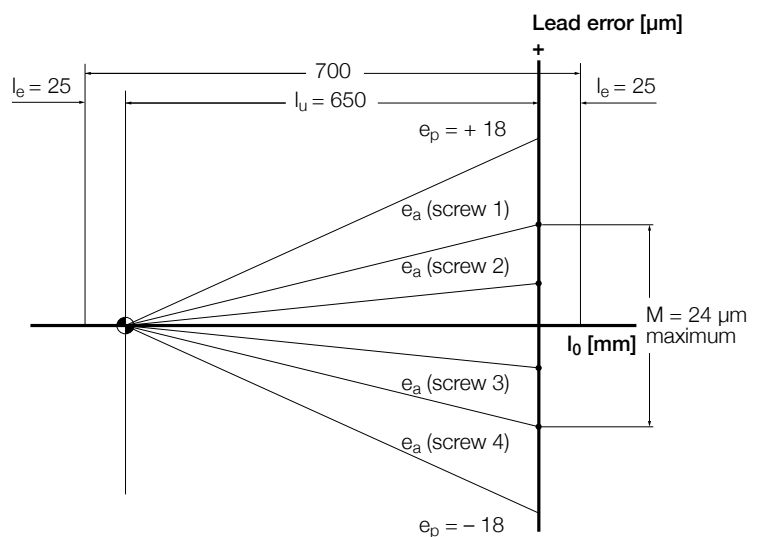

# Manufacturing tolerances

Parameters other than lead precision correspond in standard to class 5 of ISO 3408-3. If the application requires special tolerances, ISO class 3 or ISO class 1, please specify these requirements in the inquiry.

Please refer to **figure 22** and:

- **Tables 19 to 23** for manufacturing tolerances class 5
- **Tables 24 to 28** for manufacturing tolerances class 3
- **Tables 29 to 33** for manufacturing tolerances class 1

Fig. 22

## Manufacturing tolerances

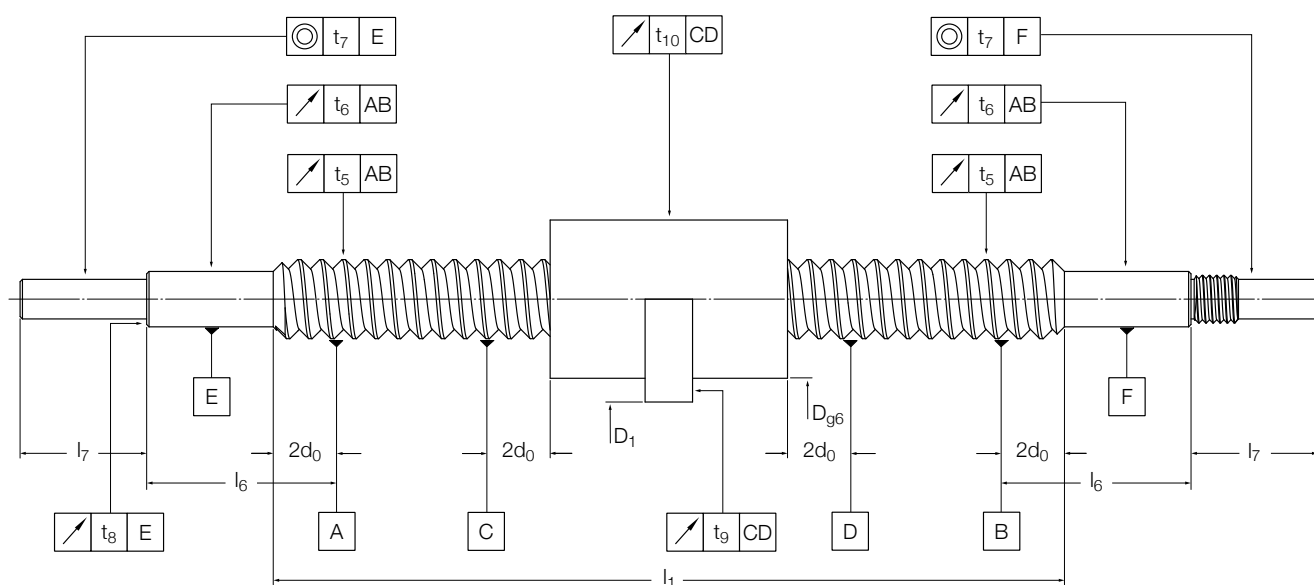

### Shaft:

- $t_5$ : straightness
- $t_6$ : radial run-out of journal diameter
- $t_7$ : concentricity of ends/journal diameter
- $t_8$ : axial run-out of bearing support face

### Nut:

- $t_9$ : axial run-out of the nut flange face
- $t_{10}$ : radial run-out of the nut diameter/screw

## Manufacturing tolerances class 5

Table 19

Nominal diameter		Threaded length $l_1$	Tolerance
$d_0$ over mm	incl.		
		$l_{1\text{ ref}}$ mm	if $l_1 \leq l_{1\text{ ref}}$ $t_5$ $\mu\text{m}$
<b>6</b>	<b>12</b>	320	32
<b>12</b>	<b>25</b>	640	32
<b>25</b>	<b>50</b>	1 260	32
<b>50</b>	<b>100</b>	2 520	32
<b>100</b>	<b>200</b>	5 000	32
<b>200</b>		1)	1)

Table 20

Ratio	Tolerance
if $l_1 > l_{1\text{ ref}}$ $l_1/d_0$ ratio	$t_5$ $\mu\text{m}$
–	
<b>≤ 40</b>	64
<b>≤ 60</b>	96
<b>≤ 80</b>	160
<b>≤ 100</b>	256

Table 21

Nominal diameter		Tolerances				
$d_0$ over mm	incl.	$t_6$	$t_{6\text{ mini}}$	$t_7$	$t_{7\text{ mini}}$	$t_8$
		$\mu\text{m}$				
<b>6</b>	<b>20</b>	$0,25 \times l_6$	20	$0,10 \times l_7$	8	5
<b>20</b>	<b>50</b>	$0,20 \times l_6$	25	$0,08 \times l_7$	10	5
<b>50</b>	<b>63</b>	$0,16 \times l_6$	32	$0,06 \times l_7$	12	5
<b>63</b>	<b>125</b>	$0,16 \times l_6$	32	$0,06 \times l_7$	12	6
<b>125</b>	<b>200</b>	$0,13 \times l_6$	40	$0,05 \times l_7$	16	8
<b>200</b>		1)	1)	1)	1)	1)

Table 22

Nut flange outer diameter		Tolerance
$D_1$ over mm	incl.	$t_9$
		$\mu\text{m}$
<b>16</b>	<b>32</b>	16
<b>32</b>	<b>63</b>	20
<b>63</b>	<b>125</b>	25
<b>125</b>	<b>250</b>	32
<b>250</b>	<b>500</b>	40

Table 23

Nut body outer diameter		Tolerance
D over mm	incl.	$t_{10}$
		$\mu\text{m}$
<b>16</b>	<b>32</b>	16
<b>32</b>	<b>63</b>	20
<b>63</b>	<b>125</b>	25
<b>125</b>	<b>250</b>	32
<b>250</b>	<b>500</b>	40

Measured by rotating the shaft and nut together

Measured by rotating the nut around the fixed shaft

1) For additional information about tolerances, please contact your local Ewellix representative

### Manufacturing tolerances class 3

Table 24

Nominal diameter		Threaded length $l_1$	Tolerance
$d_0$ over mm	incl.		
		$l_{1\text{ ref}}$ mm	if $l_1 \leq l_{1\text{ ref}}$ $t_5$ $\mu\text{m}$
<b>6</b>	<b>12</b>	320	25
<b>12</b>	<b>25</b>	640	25
<b>25</b>	<b>50</b>	1 260	25
<b>50</b>	<b>100</b>	2 520	25
<b>100</b>	<b>200</b>	5 000	25
<b>200</b>		1)	1)

Table 25

Ratio	Tolerance
if $l_1 > l_{1\text{ ref}}$ $l_1/d_0$ ratio	$t_5$ $\mu\text{m}$
–	–
<b><math>\leq 40</math></b>	50
<b><math>\leq 60</math></b>	75
<b><math>\leq 80</math></b>	125
<b><math>\leq 100</math></b>	200

Table 26

Nominal diameter		Tolerances				
$d_0$ over mm	incl.	$t_6$	$t_{6\text{ mini}}$	$t_7$	$t_{7\text{ mini}}$	$t_8$
		$\mu\text{m}$				
<b>6</b>	<b>20</b>	$0,15 \times l_6$	12	$0,08 \times l_7$	6	4
<b>20</b>	<b>50</b>	$0,13 \times l_6$	16	$0,06 \times l_7$	8	4
<b>50</b>	<b>63</b>	$0,10 \times l_6$	20	$0,05 \times l_7$	10	4
<b>63</b>	<b>125</b>	$0,10 \times l_6$	20	$0,05 \times l_7$	10	5
<b>125</b>	<b>200</b>	$0,08 \times l_6$	25	$0,04 \times l_7$	12	6
<b>200</b>		1)	1)	1)	1)	1)

Table 27

Nut flange outer diameter		Tolerance
$D_1$ over mm	incl.	
		$t_9$ $\mu\text{m}$
<b>16</b>	<b>32</b>	12
<b>32</b>	<b>63</b>	16
<b>63</b>	<b>125</b>	20
<b>125</b>	<b>250</b>	25
<b>250</b>	<b>500</b>	32

Table 28

Nut body outer diameter		Tolerance
D over mm	incl.	
		$t_{10}$ $\mu\text{m}$
<b>16</b>	<b>32</b>	12
<b>32</b>	<b>63</b>	16
<b>63</b>	<b>125</b>	20
<b>125</b>	<b>250</b>	25
<b>250</b>	<b>500</b>	32

Measured by rotating the shaft and nut together

Measured by rotating the nut around the fixed shaft

1) For additional information about tolerances, please contact your local Ewellix representative

## Manufacturing tolerances class 1

Table 29

Nominal diameter		Threaded length $l_1$	Tolerance
$d_0$ over mm	incl.		
		$l_{1\text{ ref}}$ mm	if $l_1 \leq l_{1\text{ ref}}$ $t_5$ $\mu\text{m}$
<b>6</b>	<b>12</b>	320	20
<b>12</b>	<b>25</b>	640	20
<b>25</b>	<b>50</b>	1 260	20
<b>50</b>	<b>100</b>	2 520	20
<b>100</b>	<b>200</b>	5 000	20
<b>200</b>		1)	1)

Table 30

Ratio	Tolerance
if $l_1 > l_{1\text{ ref}}$ $l_1/d_0$ ratio	$t_5$ $\mu\text{m}$
–	–
<b>≤ 40</b>	40
<b>≤ 60</b>	65
<b>≤ 80</b>	100
<b>≤ 100</b>	160

Table 31

Nominal diameter		Tolerances				
$d_0$ over mm	incl.	$t_6$	$t_{6\text{ mini}}$	$t_7$	$t_{7\text{ mini}}$	$t_8$
		$\mu\text{m}$				
<b>6</b>	<b>20</b>	$0,12 \times l_6$	10	$0,06 \times l_7$	5	3
<b>20</b>	<b>50</b>	$0,10 \times l_6$	12	$0,05 \times l_7$	6	3
<b>50</b>	<b>63</b>	$0,08 \times l_6$	16	$0,04 \times l_7$	8	3
<b>63</b>	<b>125</b>	$0,08 \times l_6$	16	$0,04 \times l_7$	8	4
<b>125</b>	<b>200</b>	1)	1)	1)	1)	1)
<b>200</b>	<b>240</b>	1)	1)	1)	1)	1)

Table 32

Nut flange outer diameter		Tolerance
$D_1$ over mm	incl.	
		$t_9$ $\mu\text{m}$
<b>16</b>	<b>32</b>	10
<b>32</b>	<b>63</b>	12
<b>63</b>	<b>125</b>	16
<b>125</b>	<b>250</b>	20
<b>250</b>	<b>500</b>	1)

Measured by rotating the shaft and nut together

Table 33

Nut body outer diameter		Tolerance
$D$ over mm	incl.	
		$t_{10}$ $\mu\text{m}$
<b>16</b>	<b>32</b>	10
<b>32</b>	<b>63</b>	12
<b>63</b>	<b>125</b>	16
<b>125</b>	<b>250</b>	20
<b>250</b>	<b>500</b>	1)

Measured by rotating the nut around the fixed shaft

1) For additional information about tolerances, please contact your local Ewellix representative

# Calculation formulae

## Basic life rating

$$L_{10} = \left( \frac{C_a}{F_m} \right)^3$$

## Required load rating

$$C_{req} = F_m (L_{10req})^{1/3}$$

where

$L_{10}$  = basic rating life [million revolutions]

$C_a$  = basic dynamic load rating [N]

$C_{req}$  = required dynamic load rating [N]

$F_m$  = cubic mean load [N]

$L_{10req}$  = required life [million revolutions]

## Equivalent mean load

• Duty cycle with step loading

$$F_m = \left( \frac{\sum F_i^3 l_i}{\sum l_i} \right)^{1/3}$$

where

$l_i$  = length of stroke segment  $i$

$F_i$  = load during stroke  $i$

$F_i$  can be either a fixed value, or a calculation for continuous load varying cycles

• Duty cycle with continuous load variation

$$F_m = \frac{F_{min} + 2 F_{max}}{3}$$

where

$F_{min}$  = minimum load

$F_{max}$  = maximum load

## Critical speed of screw shaft (no safety factor)

$$n_{cr} = 49 \times 10^6 \frac{f_1 d_2}{l_{cr}^2}$$

where

$n_{cr}$  = critical speed [r/min]

$d_2$  = screw shaft root diameter [mm]

$l_{cr}$  = free length, or distance between the two supports [mm]

$f_1$  = mounting factor

0,9 ●● — fixed, free (↳ fig. 25)

2,5 ● —● radial support, radial support (↳ fig. 26)

3,8 ●● —● fixed, radial support (↳ fig. 27)

5,6 ●● —●● fixed, fixed (↳ fig. 28)

### Notes:

- For each particular application, the most unfavorable conditions must be considered
- It is generally recommended to apply a safety factor of 0,8 to the calculated value of the critical speed  $n_{cr}$  of the screw shaft.

### Speed limit of the mechanism (maximal speed applied through very short periods)

$n d_0 \leq 160\,000$  for all types of planetary roller screws

$n d_1 \leq 30\,000$  for SV, BV, PV with  $d_1 \leq 25$  mm

$n d_1 \leq 20\,000$  for SV, BV, PV with  $d_1 > 25$  mm

where

$n$  = rotational speed [r/min]

$d_0$  = screw shaft nominal diameter for all types of planetary roller screws [mm]

$d_1$  = screw shaft nominal diameter for recirculating roller screws [mm]

Maximum permissible acceleration:

12 000 rad/s<sup>2</sup> for all types of planetary roller screws

4 000 rad/s<sup>2</sup> for all types of recirculating roller screws

Fig. 25  
Mounting factor  $f_1 = 0,9$

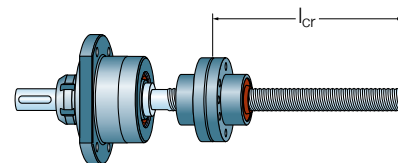

Fig. 26  
Mounting factor  $f_1 = 2,5$

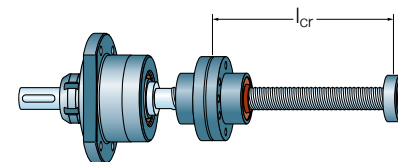

Fig. 27  
Mounting factor  $f_1 = 3,8$

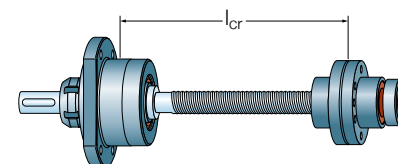
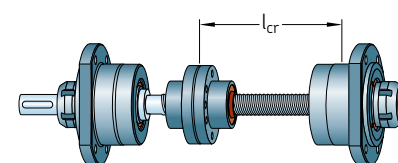

Fig. 28  
Mounting factor  $f_1 = 5,6$



### Buckling strength with safety factor 3

$$F_c = \frac{34 \times 10^3 f_3 d_2^4}{l_{Fc}^2}$$

where

$F_c$  = buckling strength [N]

$d_2$  = screw shaft root diameter [mm]

$l_{Fc}$  = distance between the fixed support bearing and the extended position of the nut [mm]

$f_3$  = mounting factor

0,25  fixed, free (→ fig. 29)

2  fixed, radial support

(→ fig. 30)

4 fixed, fixed (→ fig. 31)

### Helix angle

$$\alpha = \text{Atan} \left( \frac{P_h}{\pi d} \right)$$

where

$d$  = nominal diameter of screw shaft [mm]

- $d_0$  for SR planetary roller screws
- $d_1$  for SV recirculating roller screws
- $D_0$  for ISR inverted roller screws

$P_h$  = lead [mm]

### Theoretical efficiencies

Direct (→ diagram 2, page 24)

$$\eta = \frac{1}{1 + \frac{\pi d}{P_h} \mu_{ref}}$$

where

$\mu_{ref}$  is extracted from the coefficient of friction diagram (→ diagram 1 page 24)

$\alpha$  = helix angle [°]

$d$  = nominal diameter of screw shaft [mm]

- $d_0$  for SR planetary roller screws
- $d_1$  for SV recirculating roller screws
- $D_0$  for ISR inverted roller screws

$P_h$  = lead [mm]

Indirect (→ diagram 3, page 24)

$$\eta' = 2 - \frac{1}{\eta}$$

### Practical efficiencies

Direct (→ diagram 2, page 24)

$$\eta_p = \frac{1}{1 + \frac{\pi d}{P_h} \mu_{prac}}$$

where

$\mu_{prac}$  is extracted from the coefficient of friction diagram (→ diagram 1, page 24)

$\alpha$  = helix angle [°]

$d$  = nominal diameter of screw shaft [mm]

- $d_0$  for SR planetary roller screws
- $d_1$  for SV recirculating roller screws
- $D_0$  for ISR inverted roller screws

$P_h$  = lead [mm]

Indirect (→ diagram 3, page 24)

$$\eta' = 2 - \frac{1}{\eta_p}$$

### Input torque in a steady state

$$T = \frac{F P_h}{2000 \pi \eta_p}$$

where

$T$  = input torque [Nm]

$F$  = external load [N]

$P_h$  = lead [mm]

$\eta_p$  = practical direct efficiency

### Power requirement in a steady state

$$P = \frac{F n P_h}{60000 \eta_p}$$

where

$P$  = power required [W]

$n$  = revolutions per minute [r/min]

### Preload torque

$$T_{pr} = \frac{F_{pr} P_h}{1000 \pi} \left( \frac{1}{\eta_p} - 1 \right)$$

where

$T_{pr}$  = preload torque [N]

$F_{pr}$  = preload force [N]

### Braking torque (the restraining torque considered in a back-driving system)

$$T_b = \frac{F P_h \eta'}{2000 \pi}$$

where

$T_b$  = braking torque [Nm]

$F$  = external load [N]

To consider the worst case conditions, we use the theoretical indirect efficiency.

Fig. 29

Mounting factor  $f_3 = 0,25$

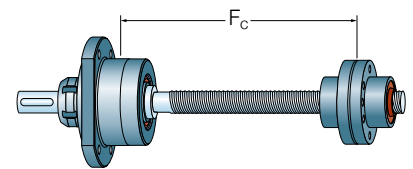

Fig. 30

Mounting factor  $f_3 = 2$

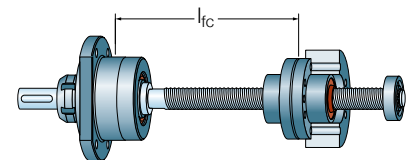
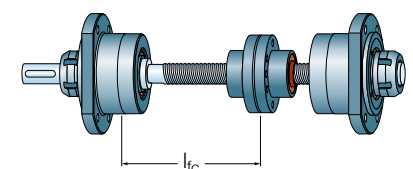

Fig. 31

Mounting factor  $f_3 = 4$



### Nominal motor torque during acceleration

For a horizontal screw

$$T_t = T_f + T_{pr} + \frac{P_h(F + m_L \mu_f g)}{2\,000 \pi \eta_p} + \dot{\omega} \Sigma I$$

For a vertical screw

$$T_t = T_f + T_{pr} + \frac{P_h(F + m_L g)}{2\,000 \pi \eta_p} + \dot{\omega} \Sigma I$$

where

$T_t$  = driving torque [Nm]

$T_f$  = friction torque in support bearings, motors, seals, etc... [Nm]

$T_{pr}$  = preload torque [Nm]

$\mu_f$  = coefficient of friction of guidance systems

$\dot{\omega}$  = angular acceleration [rad/s<sup>2</sup>]

$m_L$  = mass in movement [kg]

$g$  = acceleration of gravity [9,8 m/s<sup>2</sup>]

$\Sigma I = I_M + I_L + I_S \cdot 10^{-9}$

where

$$I_L = m_L \left( \frac{P_h}{2\pi} \right)^2 \cdot 10^{-6}$$

where

$I_M$  = inertia of motor [kgm<sup>2</sup>]

$I_S$  = inertia of screw shaft per meter [kgmm<sup>2</sup>/m]

$l$  = length of screw shaft [mm]

For a hollow shaft, the actual inertia is calculated as follows:

$$I_{S \text{ actual}} = I_S \cdot 10^{-9} \left( \frac{d_o^4 - d_b^4}{d_o^4} \right)$$

where

$d_b$  = bore diameter of the shaft [mm]

### Nominal braking torque during deceleration

For a horizontal screw

$$T'_b = \frac{P_h \eta' [F + m_L \mu_f g]}{2\,000 \pi} + \dot{\omega} \Sigma I - T_f - T_{pr}$$

For a vertical screw

$$T'_b = \frac{P_h \eta' [F + m_L g]}{2\,000 \pi} + \dot{\omega} \Sigma I - T_f - T_{pr}$$

where

$T'_b$  = braking torque during deceleration [Nm]

### Static axial stiffness of a complete roller screw assembly

$$\frac{1}{R_t} = \frac{1}{R_s} + \frac{1}{R_n} + \frac{1}{R_p}$$

where

$R_t$  = stiffness of a complete assembly [N/μm]

$R_s$  = shaft stiffness [N/μm]

$R_n$  = nut stiffness [N/μm]

$R_p$  = support bearings stiffness [N/μm]

### Shaft stiffness

Fixed-free or fixed-radial support

$$R_s = 165 \frac{d_2^2}{l_{s1}} \quad (\rightarrow \text{fig. 32})$$

Fixed-fixed assembly

$$R_s = \frac{165 d_2^2 I_s}{l_{s1} (l_s - l_{s1})} \quad (\rightarrow \text{fig. 33})$$

### Note:

The lowest stiffness is reached when the nut is in central position

$$l_{s1} = \frac{l_s}{2} \rightarrow R_s = \frac{165 d_2^2}{l_s} \times 4$$

where

$l_{s1}$  = distance between center of fixed support bearing and center of nut [mm]

$l_s$  = distance between centers of fixed support bearings

For additional information, please contact your local Ewellix representative.

**Fig. 32**  
Configuration with fixed support and radial support for stiffness calculation

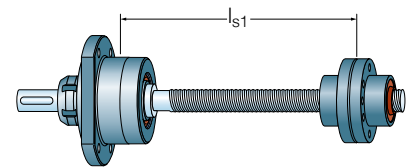

**Fig. 33**  
Configuration with two fixed supports for stiffness calculation

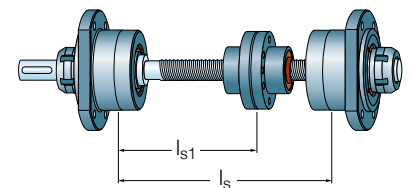

## Calculation example

- Customer wishes to select a planetary roller screw for his application
- To achieve the required linear speed of the application, customer has preselected a lead of 20 mm. Screw rotational speed is 600 r/min during the operation cycle
- Nut type should be flanged for assembly purposes
- Roller screw shaft is horizontally mounted, with one fixed end on the start position, and the other end on radial support
- Load cycle is shown in **diagram 12**
- Operation is 1 cycle/minute, 7 hours/day, 260 days /year for 5 years minimum

### Calculation of equivalent mean load $F_m$

$$F_1 = 50\,000\text{ N} \quad \text{on } L_1 = 1\,500\text{ mm}$$

$$F_{2m} = \frac{2F_1 + F_2}{3} = 45\,833\text{ N} \quad \text{on } L_2 = 1\,000\text{ mm}$$

$$F_{3m} = 37\,500\text{ N} \quad \text{on } L_3 = 1\,250\text{ mm}$$

$$F_{4m} = 20\,500\text{ N} \quad \text{on } L_3 = 1\,250\text{ mm}$$

$$F_m = \sqrt{\frac{50\,000^3 \times 1\,500 + 45\,833^3 \times 1\,000 + 37\,500^3 \times 1\,250 + 20\,000^3 \times 1\,250}{1\,500 + 1\,000 + 1\,250 + 1\,250}}$$

$$F_m = 41\,590\text{ N}$$

### Calculation of required dynamic carrying capacity $C_{a\text{ req}}$

With consideration to the operational cycle:

With the preselection of lead  $P_h = 20\text{ mm}$

Minimum  $L_{10} = 60 \times 7 \times 260 \times 5 = 546\,000\text{ cycles}$

$$L_{10} = 546\,000 \frac{1\,500 + 1\,000 + 1\,250 + 1\,250}{20} = 136,5 \times 10^6\text{ revolutions}$$

$$C_{a\text{ req}} = F_m (L_{10})^{1/3} = 41\,590 (136,5)^{1/3} = 214\,141\text{ N}$$

Looking at the product tables, we find that:

SRF 48 x 20R with  $C_a = 265\,690\text{ N}$  satisfies the requirement of minimum dynamic carrying capacity

### Selection of support bearing

The table on **page 109** indicates that support bearing size FLRBU7 is recommended for screw type SRF 48 x 20R.

In the following calculations, we will assume that the radial support at the other end of the screw shaft has a total width of 50 mm.

Diagram 12

Application load cycle

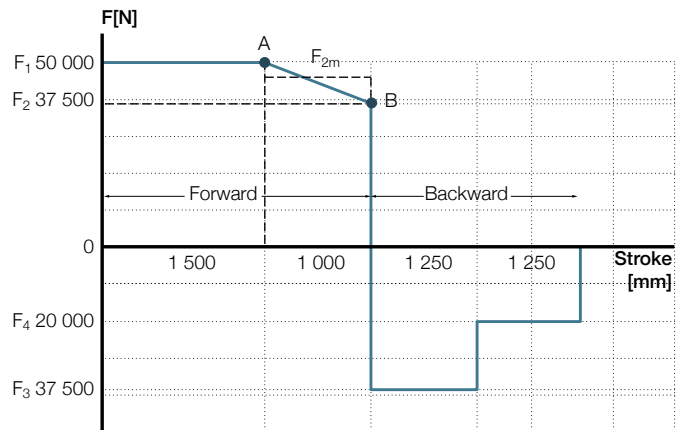

## Efficiencies

### Theoretical direct efficiency

$$\alpha = \text{Atan} \left( \frac{P_h}{\mu d_0} \right) = 7,55^\circ$$

Taken from the coefficient of friction reference diagram (L → **diagram 1, page 24**)

where

$$\mu_{\text{ref}} = 0,016$$

$$\mu_{\text{prac}} = 0,021$$

$$\eta = \frac{1}{1 + \frac{\pi d_0}{P_h} \mu_{\text{ref}}} = 0,892$$

**Theoretical indirect efficiency**

$$\eta' = 2 - \frac{1}{\eta} = 0,879$$

**Practical direct efficiency**

We consider the practical coefficient of friction  $\mu_{prac} = 0,021$

$$\eta_p = \frac{1}{1 + \frac{\pi d_0 \mu_{prac}}{P_h}} = 0,863$$

**Input torque in a steady state**

Phase 1 has the highest application load  $F_{max} = 50\,000\text{ N}$

$$T = \frac{F P_h}{2\,000 \pi \eta_p} = \frac{50\,000 \times 20}{2\,000 \pi \times 0,863} = 184,4\text{ Nm}$$

**Power requirement in a steady state**

Phase 1 has the highest application load  $F_{max} = 50\,000\text{ N}$

Rotational speed is 600 r/min

$$P = \frac{50\,000 \times 600 \times 20}{60\,000 \times 0,863} = 11\,587\text{ W}$$

**Braking torque**

Phase 1 has the highest application load  $F_{max} = 50\,000\text{ N}$

$$T_b = \frac{50\,000 \times 20 \times 0,879}{2\,000 \pi} = 139,9\text{ Nm}$$

**Critical speed of screw shaft**

For the critical speed evaluation, we have to consider the most critical configurations for the screw, where we encounter the longest shaft free length. In the present case study, the two most critical configurations are:

**A)** Nut at start position (zero stroke) that gives a free length of 2 608,5 mm between the center of the nut and the center of the radial support at the end of the shaft (→ page 49 and fig. 34).

In this configuration, the mounting conditions are supported/supported with a corresponding factor  $f_1 = 2,5$ . The root diameter  $d_2 = 45,5\text{ mm}$ , the calculated critical speed is:

$$n_{cr} = 49 \times 10^6 \frac{2,5 \times 45,5}{2\,608,5^2} = 819\text{ r/min}$$

By applied a safety factor of 0,8:

$$n_{cr} \times 0,8 = 819 \times 0,8 = 655\text{ r/min} > 600\text{ r/min} \rightarrow \text{Ok}$$

**B)** Nut at full stroke of 2 500 mm that gives a free length of 2 719,5 mm between the center of the nut and the center of the fixed support bearing (→ page 49, fig. 35).

In this configuration, the mounting conditions are fixed/supported with corresponding factor  $f_1 = 3,8$

The calculation is:

$$n_{cr} = 49 \times 10^6 \frac{3,8 \times 45,5}{2\,719,5^2} = 1\,146\text{ r/min}$$

$$n_{cr} \times 0,8 = 1146 \times 0,8 = 917\text{ r/min} > 600\text{ r/min} \rightarrow \text{Ok}$$

**Speed limit**

$$n_{d_0} = 600 \times 48 = 28\,000 < 160\,000 \rightarrow \text{Ok}$$

**Buckling strength with safety factor = 3**

We must consider two critical situations for calculating the buckling strength.

Point **(A)** (→ diagram 12, page 47) with maximum application load at end of phase 1 (travel = 1 500 mm) (→ fig. 36, page 49).

In this configuration, the mounting conditions are fixed/supported with corresponding factor  $f_3 = 2$

$$F_{cr} = \frac{34 \times 10^3 \times 2 \times 45,5^4}{1\,719,5^2} = 98\,571\text{ N} > F_1 = 50\,000\text{ N} \rightarrow \text{Ok}$$

Point **(B)** (→ diagram 12, page 47) with lower application load and longer total travel of 2 500 mm at end of phase 2 (→ fig. 37, page 49)

$$F_c = \frac{34 \times 10^3 \times 2 \times 45,5^4}{2\,719,5^2} = 39\,407\text{ N} > F_2 = 37\,500\text{ N} \rightarrow \text{Ok}$$

**Same case with customer selecting a preloaded roller screw**

Should the customer prefer a preloaded roller screw for the application in order to have a stiffer assembly, then the initial selection would be:

PRK 60 x 20R with  $C_a = 217\,610\text{ N}$

Now check this screw against all dimensioning parameters.

## Efficiencies

### Theoretical direct efficiency

$$\alpha = \text{Atan} \left( \frac{P_h}{\pi d_0} \right) = 6,05^\circ$$

Taken from the coefficient of friction reference diagram

(↳ diagram 1, page 24)

where

$$\mu_{\text{ref}} = 0,013$$

$$\mu_{\text{prac}} = 0,017$$

$$\eta = \frac{1}{1 + \frac{\pi d_0 \mu_{\text{ref}}}{P_h}} = 0,891$$

### Theoretical indirect efficiency

$$\eta' = 2 - \frac{1}{\eta} = 0,877$$

### Practical direct efficiency

We consider the practical coefficient of friction

$$m_{\text{prac}} = 0,017$$

$$\eta = \frac{1}{1 + \frac{\pi d_0 \mu_{\text{prac}}}{P_h}} = 0,862$$

### Input torque in a steady state

Phase 1 has the highest application load  $F_{\text{max}} = 50\,000\text{ N}$

$$T = \frac{50\,000 \times 20}{2\,000 \pi \times 0,862} = 184,6\text{ Nm}$$

### Power requirement in a steady state

Phase 1 has the highest application load  $F_{\text{max}} = 50\,000\text{ N}$

Rotational speed is 600 r/min

$$P = \frac{50\,000 \times 600 \times 20}{60\,000 \times 0,862} = 11\,600\text{ W}$$

Fig. 34

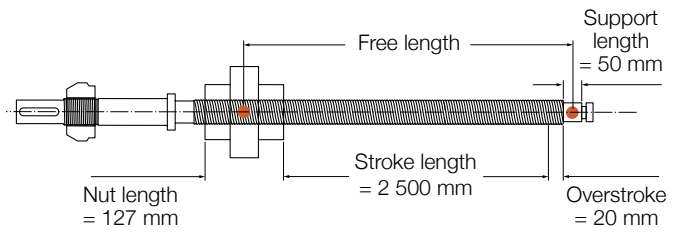

$$\text{Free length} = 127/2 + 2\,500 + 20 + 50/2 = 2\,608,50$$

Fig. 35

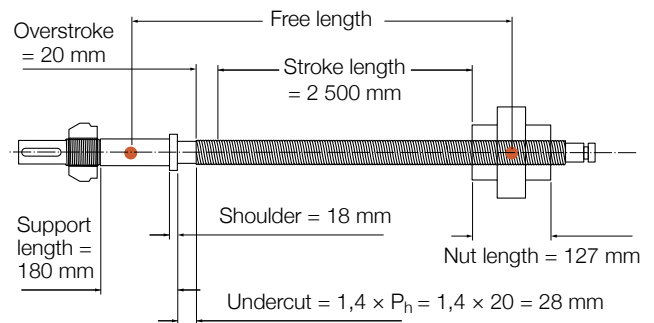

$$\text{Free length} = 127/2 + 2\,500 + 20 + 28 + 18 + 180/2 = 2\,719,50$$

Fig. 36

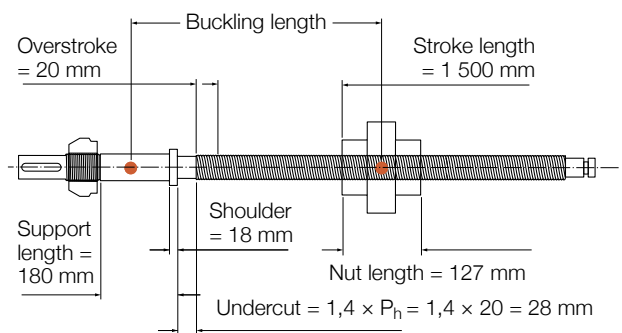

$$\text{Buckling length} = 127/2 + 1\,500 + 20 + 28 + 18 + 180/2 = 1\,719,50$$

Fig. 37

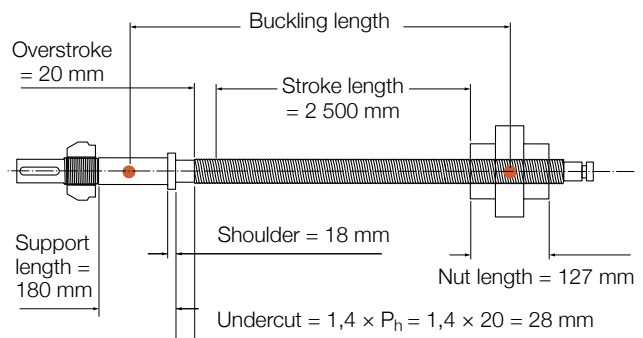

$$\text{Buckling length} = 127/2 + 2\,500 + 20 + 28 + 18 + 180/2 = 2\,719,50$$

## Braking torque

Phase 1 has the highest application load  $F_{\max} = 50\,000\text{ N}$

$$T_b = \frac{F P_n \eta'}{2\,000 \pi} = \frac{50\,000 \times 20 \times 0,877}{2\,000 \pi} = 139,6\text{ Nm}$$

## Critical speed of screw shaft

Screw type PRK 60 x 20R has a larger nominal diameter and a larger root diameter than screw type SRF 48 x 20R that was already calculated. Therefore, the critical speed will not be a problem for screw size PRK 60 x 20R.

## Axial stiffness

In product table on **page 75**, we find that nominal preload  $F_{pr} = 2\,326\text{ N}$

First, we confirm that the internal preload is appropriate for the application:

- Minimum application load in phase 4:  
 $F_4 = 20\,000\text{ N}$
- $F_4$  is greater than  $2,83 \times 2\,326\text{ N} = 6\,583\text{ N}$

This is to make sure that the nut half that does not carry the load is completely unloaded and does not face marginal loading with risk of sliding. Nominal preload  $F_{pr} = 2\,326\text{ N}$  is OK for the application.

Under this nominal preload conditions ( $F_{pr} = 2\,326\text{ N}$ ), the minimum nominal stiffness of the nut is  $R_{ng} = 700\text{ N}/\mu\text{m}$  (product table on **page 75**).

Total axial stiffness of the roller screw is:

$$\frac{1}{R_t} = \frac{1}{R_s} + \frac{1}{R_{ng}}$$

At point **(B)** (↳ **diagram 12, page 47**), full stroke:

With  $d_2 = 57,5\text{ mm}$  for roller screw size PRK 60 x 20R

$$R_s = 165 \frac{57,5^2}{2719,5} = 201\text{ N}/\mu\text{m}$$

$$\frac{1}{R_t} = \frac{1}{201} + \frac{1}{700} \quad \text{↳} \quad R_t = 156\text{ N}/\mu\text{m} \text{ at full stroke}$$

If we include the axial stiffness of the fixed support bearing FLRBU7, we calculate the total system stiffness:

R support bearing =  $1\,250\text{ N}/\mu\text{m}$

$$\frac{1}{R_{\text{total system}}} = \frac{1}{R_2} + \frac{1}{R_{ng}} + \frac{1}{R_{\text{bearing}}} = \frac{1}{201} + \frac{1}{700} + \frac{1}{1\,250}$$

↳ R total system =  $139\text{ N}/\mu\text{m}$  at full stroke

3

**Product range**

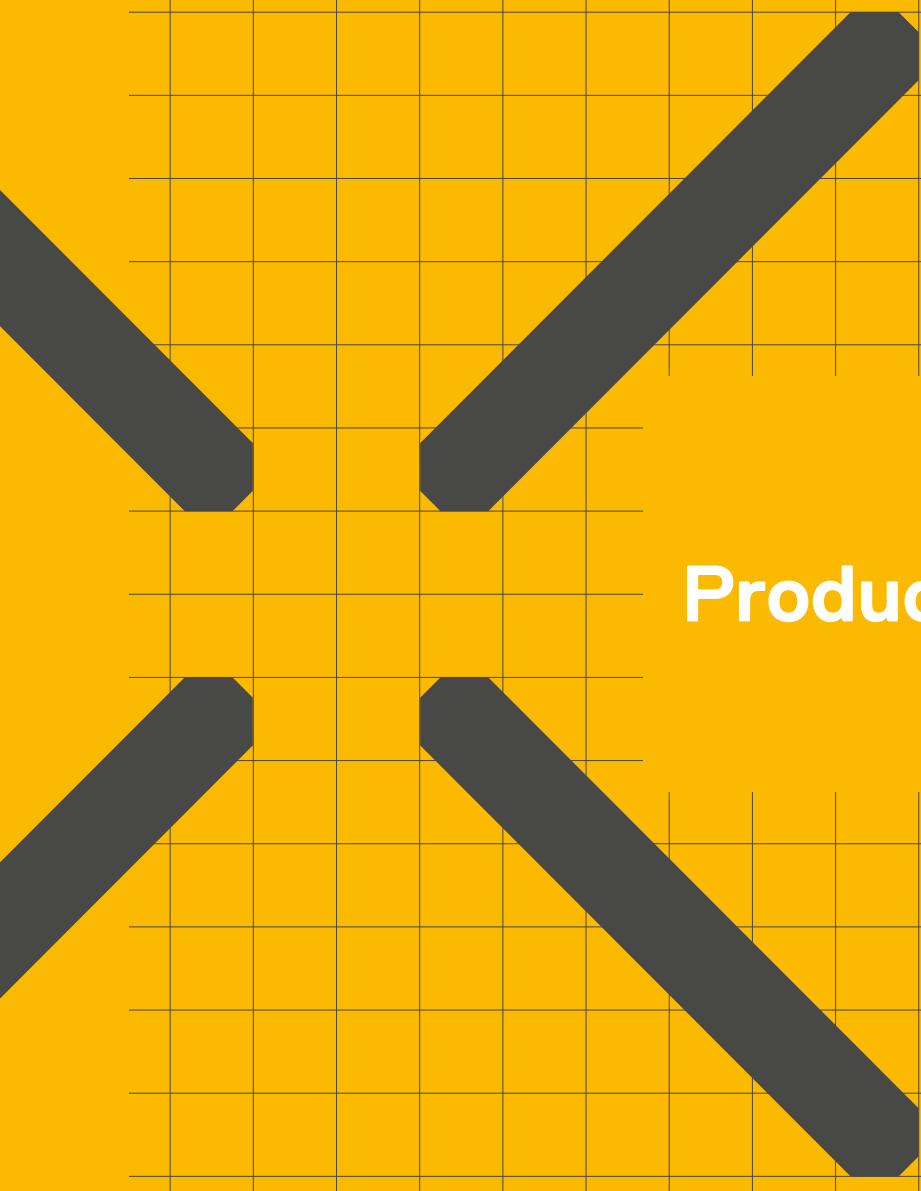

# Planetary roller screws SR

## Concept

Planetary roller screws operating without recirculation provide the high level of robustness, load carrying capacity, speed and acceleration, service life and reliability for ultimate driving performance.

## Application examples

- Presses for plastic injection moulding and blow moulding
- Electro-mechanical presses
- Broaching machines
- Large machine tools
- Car assembly lines (spot welding, gluing, riveting, etc.)
- Factory automation
- Off-highway vehicles
- Oil & gas
- Aerospace
- Steel industry
- Test benches

Design features	User benefits
Satellite rollers without recirculation	Maximum reliability, high speed capability, low noise
Evenly spaced, guided and synchronized rollers	Robustness, resistance to shocks Very well adapted for operation with frequent changes of direction without friction torque singularities Operation within contaminated environments Smooth running
Absence of miniature parts	Very robust and durable
Nominal diameters from 8 to 120 mm	Wide standard assortment to fit most customer applications
Long leads up to 42 mm	High linear speeds up to 1,8 m/s for size 44 x 30
Small leads down to 2 mm	Ideal combination of precise positioning accuracy, increased load carrying capacity, axial stiffness, high speed and low torque requirements
Shaft length up to 8 000 mm	For additional information about longer shaft lengths, please contact your local Ewellix representative
Maximum $n \cdot d_0 = 160\,000$ Acceleration up to $12\,000 \text{ rad/s}^2$ for standard SR screws, and can be higher for special variants	High speed rating of rolling screw, improving customer productivity
High dynamic load carrying capacity up to 1 131 kN for SR assortment	Long service life
High static load carrying capacity up to 4 038 kN for SR assortment	Ability to accommodate heavy shock loads without raceway damage
High axial stiffness, further increased with a preloaded version	High positioning accuracy
Roller retention for nut and shaft disassembly	Easy roller screw assembly into customer machinery, no need of sleeve like for ball screws
Optional support bearings	Complete support bearings ready to use, simplified application design and assembly, easy ordering process
Three standard versions are available: <ul style="list-style-type: none"> <li>• SR with axial play</li> <li>• BR without backlash (for <math>d_0 \leq 64 \text{ mm}</math>)</li> <li>• PR with preloaded split nut (for <math>d_0 \leq 64 \text{ mm}</math>)</li> </ul>	Equipment stiffness and accuracy further increased with the preloaded version Increased load rating within the same roller nut design
On request, the SR assortment can be delivered with maximized load rating (maximum number of rollers) for sizes $d_0 \leq 80 \text{ mm}$	Increased load rating within the same roller nut design
Flexible design and manufacturing equipment	Custom designs to fit customer applications, e.g. left hand threads

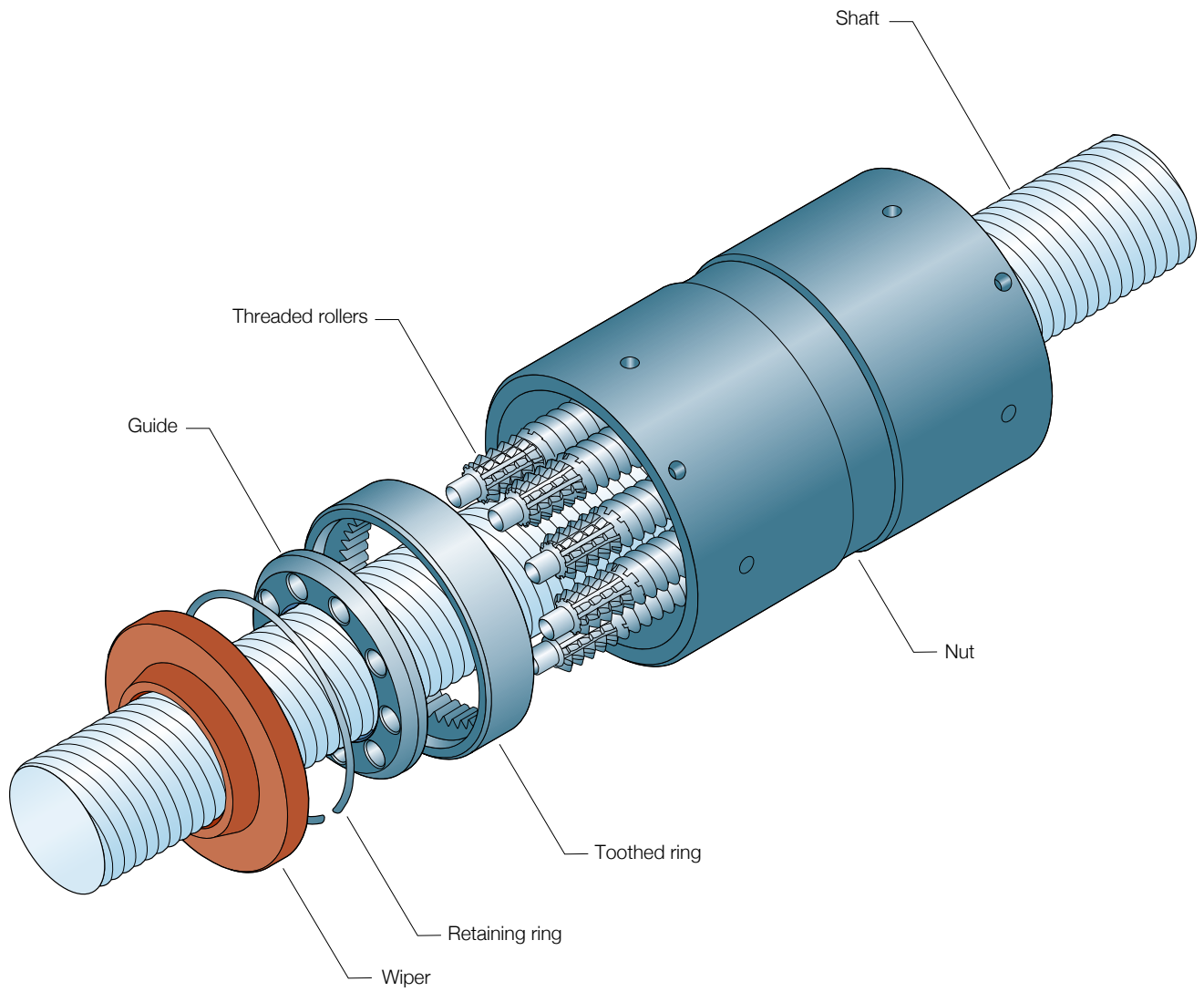

SRC/BRC planetary roller screws with cylindrical nut

d 8 – 30 mm



Standard SRC



Threaded rollers



Components assembly

Dimensions and technical characteristics

d <sub>0</sub>	P <sub>h</sub>	L <sub>ip</sub> <sup>3)</sup>	C <sub>a</sub> <sup>1)</sup>	C <sub>oa</sub> <sup>1)</sup>	C <sub>a</sub> <sup>2)</sup> max	C <sub>oa</sub> <sup>2)</sup> max	η	η'	S <sub>ap</sub>	T <sub>be</sub>	m <sub>n</sub>	m <sub>s</sub>	l <sub>s</sub>	l <sub>nn</sub>	l <sub>ns</sub>	Z <sub>n</sub>	Z <sub>s</sub>
			kN				-		mm	Nm	kg	kg/m	kgmm <sup>2</sup> /m	kgmm <sup>2</sup>		cm <sup>3</sup>	cm <sup>3</sup> /m
8	2	500	-	-	8,61	16	0,88	0,87	0,02	0,1	0,1	0,4	3,20	11,4	0,2	0,8	4
	4	500	-	-	8,93	13,4	0,88	0,87	0,02	0,1	0,1	0,4	3,20	11,4	0,2	0,9	4
12	2	750	-	-	13,2	22,5	0,86	0,83	0,02	0,1	0,1	0,9	16,0	22,9	0,3	1,1	6
	5	750	14,1	18,3	15,1	20,4	0,89	0,88	0,02	0,1	0,2	0,9	16,0	22,9	0,4	1,4	6
15	2	975	-	-	23,9	52,7	0,84	0,80	0,02	0,2	0,2	1,4	39,0	45,2	1,5	1,9	7
	5	975	26	43,6	29,7	53,3	0,89	0,88	0,02	0,2	0,2	1,4	39,0	45,2	1,2	2,3	7
	8	975	27,4	40,8	29,4	45,3	0,88	0,86	0,02	0,2	0,2	1,4	39,0	45,2	1,2	2,3	7
18	2	1 200	-	-	30,4	71,0	0,82	0,77	0,02	0,3	0,35	2,0	81,0	81,0	3,0	4,0	8
	5	1 200	-	-	37,7	70,9	0,89	0,87	0,02	0,3	0,35	2,0	81,0	81,0	3,0	4,0	8
	8	1 200	-	-	38,0	61,5	0,89	0,87	0,02	0,3	0,35	2,0	81,0	81,0	3,0	4,0	8
21	2	1 400	-	-	47,4	103	0,80	0,74	0,02	0,3	0,4	2,7	150	141	6,5	5,0	10
	5	1 400	50,6	82,0	57,8	100	0,88	0,86	0,02	0,3	0,4	2,7	150	141	6,5	5,0	10
	6	1 400	52,8	82,2	60,3	100	0,89	0,87	0,02	0,3	0,4	2,7	150	141	6,5	5,0	10
	8	1 400	57	84,1	65,2	103	0,89	0,88	0,02	0,3	0,4	2,7	150	141	6,5	5,0	10
	10	1 400	59,2	83	63,6	92,2	0,89	0,87	0,04	0,3	0,4	2,7	150	141	6,5	5,0	10
24	6	1 600	42,3	65,2	47,3	77	0,88	0,87	0,02	0,4	0,5	3,6	256	173	6,3	4,0	11
	12	1 600	47,7	62,3	53,3	73,7	0,88	0,87	0,04	0,4	0,5	3,6	256	173	6,3	4,0	11
25	5	1 650	68,4	122	78,2	149	0,87	0,85	0,02	0,4	0,7	3,9	301	322	14,3	10	11
	8	1 650	76,1	122	87,0	149	0,89	0,88	0,02	0,4	0,7	3,9	301	322	14,3	10	11
	10	1 650	78,6	118	89,8	145	0,89	0,88	0,04	0,4	0,7	3,9	301	322	14,3	10	11
	15	1 650	85,6	120	91,9	133	0,87	0,85	0,07	0,4	0,7	3,9	301	322	14,3	10	11
30	5	2 000	92	178	105	218	0,86	0,83	0,02	0,6	1,2	5,6	624	762	36,2	14	14
	6	2 000	95	175	109	214	0,87	0,85	0,02	0,6	1,2	5,6	624	762	36,2	14	14
	8	2 000	103	178	117	218	0,88	0,87	0,02	0,6	1,2	5,6	624	762	36,2	14	14
	10	2 000	106	174	122	213	0,89	0,88	0,04	0,6	1,2	5,6	624	762	36,2	14	14
	15	2 000	119	182	127	201	0,88	0,87	0,07	0,6	1,2	5,6	624	762	36,2	14	14
	20	2 000	123	177	132	197	0,86	0,83	0,07	0,8	1,2	5,6	624	762	35,9	14	14

Preferred range

<sup>1)</sup> Standard number of rollers. Configuration not available for certain sizes

<sup>2)</sup> Maximum number of rollers on request, or standard for certain sizes

<sup>3)</sup> For BRC (backlash eliminated), maximum length can be shorter

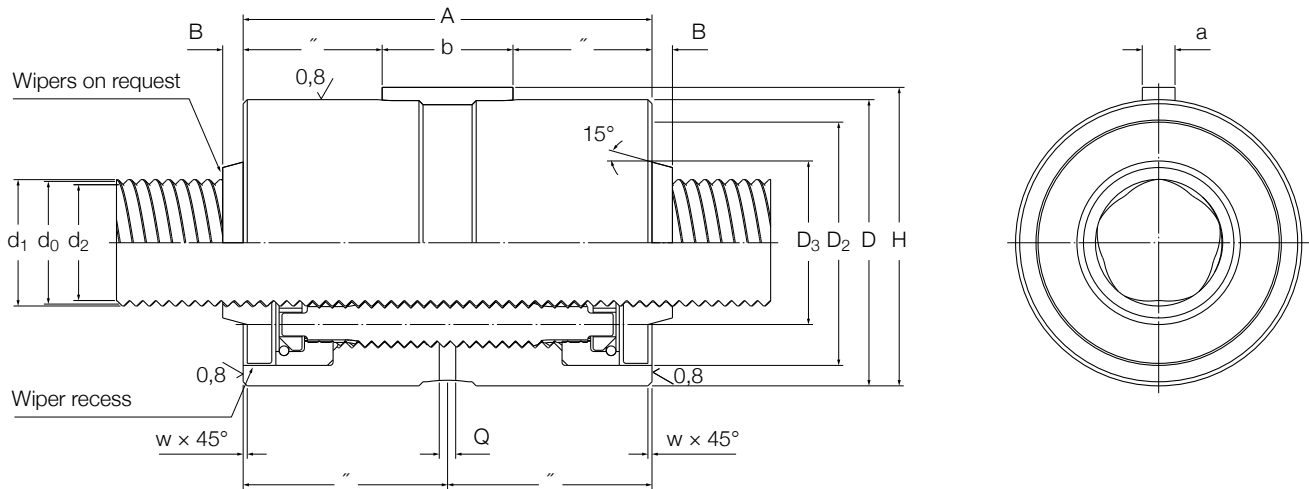

Designation	Dimensions											
	d <sub>1</sub>	d <sub>2</sub>	D	A	w	a	b	H	Q	B	D <sub>2</sub>	D <sub>3</sub>
-	mm											
SRC/BRC 8 x 2	8,2	7,6	25	44	0,5	4	12	26,5	5	3	21	13
SRC/BRC 8 x 4	8,4	7,3	25	44	0,5	4	12	26,5	5	3	21	13
SRC/BRC 12 x 2	12,2	11,6	30	44	0,5	4	12	31,5	5	3	25	17
SRC/BRC 12 x 5	12,4	11,3	30	44	0,5	4	12	31,5	5	3	25	17
SRC/BRC 15 x 2	15,2	14,6	35	50	0,5	4	16	36,5	5	3	30	20
SRC/BRC 15 x 5	15,4	14,3	35	50	0,5	4	16	36,5	5	3	30	20
SRC/BRC 15 x 8	15,6	14	35	50	0,5	4	16	36,5	5	3	30	20
SRC/BRC 18 x 2	18,2	17,6	40	58	0,5	5	18	42	5	3	35	23
SRC/BRC 18 x 5	18,4	17,3	40	58	0,5	5	18	42	5	3	35	23
SRC/BRC 18 x 8	18,6	17	40	58	0,5	5	18	42	5	3	35	23
SRC/BRC 21 x 2	21,2	20,6	45	64	0,5	5	20	47	5	4	40,5	26
SRC/BRC 21 x 5	21,4	20,3	45	64	0,5	5	20	47	5	4	40,5	26
SRC/BRC 21 x 6	21,5	20,2	45	64	0,5	5	20	47	5	4	40,5	26
SRC/BRC 21 x 8	21,6	20	45	64	0,5	5	20	47	5	4	40,5	26
SRC/BRC 21 x 10	21,8	19,8	45	64	0,5	5	20	47	5	4	40,5	26
SRC/BRC 24 x 6	24,4	23,3	48	58	0,5	5	20	50	5	6	42	31
SRC/BRC 24 x 12	24,8	22,8	48	58	0,5	5	20	50	5	6	42	31
SRC/BRC 25 x 5	25,4	24,3	53	78	0,5	6	25	55,5	5	6	47	32
SRC/BRC 25 x 8	25,6	24	53	78	0,5	6	25	55,5	5	6	47	32
SRC/BRC 25 x 10	25,8	23,8	53	78	0,5	6	25	55,5	5	6	47	32
SRC/BRC 25 x 15	26,2	23,2	53	78	0,5	6	25	55,5	5	6	47	32
SRC/BRC 30 x 5	30,4	29,4	64	85	0,5	6	32	66,5	5	7	58	38
SRC/BRC 30 x 6	30,5	29,3	64	85	0,5	6	32	66,5	5	7	58	38
SRC/BRC 30 x 8	30,6	29	64	85	0,5	6	32	66,5	5	7	58	38
SRC/BRC 30 x 10	30,8	28,8	64	85	0,5	6	32	66,5	5	7	58	38
SRC/BRC 30 x 15	31,2	28,3	64	85	0,5	6	32	66,5	5	7	58	38
SRC/BRC 30 x 20	31,5	27,6	64	85	0,5	6	32	66,5	5	7	58	38



SRC/BRC planetary roller screws with cylindrical nut

d 36 – 56 mm



Standard SRC



Threaded rollers



Components assembly

Dimensions and technical characteristics

d <sub>0</sub>	P <sub>h</sub>	L <sub>tp</sub> <sup>3)</sup>	C <sub>a</sub> <sup>1)</sup>	C <sub>oa</sub> <sup>1)</sup>	C <sub>a</sub> <sup>2)</sup> max	C <sub>oa</sub> <sup>2)</sup> max	η	η'	S <sub>ap</sub>	T <sub>be</sub>	m <sub>n</sub>	m <sub>s</sub>	I <sub>s</sub>	I <sub>nn</sub>	I <sub>ns</sub>	Z <sub>n</sub>	Z <sub>s</sub>	
			kN				-		mm	Nm	kg	kg/m	kgmm <sup>2</sup> /m	kgmm <sup>2</sup>			cm <sup>3</sup>	cm <sup>3</sup> /m
<b>36</b>	6	2 400	90,5	179	106	228	0,86	0,83	0,02	0,8	1,2	8,0	1 290	923	46	13	16	
	9	2 400	97,5	174	115	222	0,88	0,87	0,02	0,8	1,2	8,0	1 290	923	46	13	16	
	12	2 400	107	181	125	230	0,89	0,88	0,04	0,8	1,2	8,0	1 290	873	46	13	16	
	18	2 400	114	177	128	209	0,88	0,87	0,07	0,8	1,2	8,0	1 290	873	46	13	16	
	24	2 400	124	184	138	218	0,86	0,83	0,07	0,8	1,2	8,0	1 290	873	46	13	16	
<b>39</b>	<b>5</b>	<b>2 650</b>	<b>129</b>	<b>269</b>	<b>148</b>	<b>329</b>	<b>0,83</b>	<b>0,80</b>	<b>0,02</b>	<b>0,9</b>	<b>2,1</b>	<b>9,4</b>	<b>1 780</b>	<b>2 030</b>	<b>124</b>	<b>28</b>	<b>18</b>	
	<b>10</b>	<b>2 650</b>	<b>153</b>	<b>271</b>	<b>174</b>	<b>331</b>	<b>0,88</b>	<b>0,87</b>	<b>0,04</b>	<b>0,9</b>	<b>2,1</b>	<b>9,4</b>	<b>1 780</b>	<b>2 030</b>	<b>124</b>	<b>28</b>	<b>18</b>	
	15	2 650	168	273	192	334	0,89	0,88	0,07	0,9	2,1	9,4	1 780	2 030	124	28	18	
	20	2 650	173	261	198	319	0,88	0,87	0,07	0,9	2,1	9,4	1 780	2 030	124	28	18	
	25	2 650	175	249	188	277	0,86	0,84	0,07	0,9	2,1	9,4	1 780	2 030	124	28	18	
<b>44</b>	8	3 000	130	261	153	333	0,86	0,84	0,02	1,1	1,7	11,9	2 890	1 730	119	23	20	
	12	3 000	144	263	169	335	0,89	0,87	0,04	1,1	1,7	11,9	2 890	1 730	119	23	20	
	18	3 000	158	265	185	337	0,89	0,88	0,07	1,1	1,7	11,9	2 890	1 730	118	23	20	
	24	3 000	168	267	188	315	0,88	0,86	0,07	1,1	1,7	11,9	2 890	1 730	118	23	20	
	30	3 000	166	246	185	291	0,85	0,83	0,07	1,1	1,7	11,9	2 890	1 730	118	23	20	
<b>48</b>	<b>5</b>	<b>3 300</b>	<b>198</b>	<b>482</b>	<b>240</b>	<b>642</b>	<b>0,81</b>	<b>0,76</b>	<b>0,02</b>	<b>1,3</b>	<b>4,2</b>	<b>14,2</b>	<b>4 090</b>	<b>6 520</b>	<b>371</b>	<b>54</b>	<b>22</b>	
	8	3 300	218	471	250	575	0,86	0,83	0,02	1,3	4,2	14,2	4 090	6 520	371	54	22	
	<b>10</b>	<b>3 300</b>	<b>232</b>	<b>475</b>	<b>265</b>	<b>581</b>	<b>0,87</b>	<b>0,85</b>	<b>0,04</b>	<b>1,3</b>	<b>4,2</b>	<b>14,2</b>	<b>4 090</b>	<b>6 520</b>	<b>371</b>	<b>54</b>	<b>22</b>	
	15	3 300	258	486	295	594	0,89	0,88	0,07	1,3	4,2	14,2	4 090	6 520	371	54	22	
	<b>20</b>	<b>3 300</b>	<b>266</b>	<b>462</b>	<b>304</b>	<b>565</b>	<b>0,89</b>	<b>0,88</b>	<b>0,07</b>	<b>1,3</b>	<b>4,2</b>	<b>14,2</b>	<b>4 090</b>	<b>6 520</b>	<b>371</b>	<b>54</b>	<b>22</b>	
	25	3 300	286	491	327	600	0,88	0,87	0,07	1,3	4,2	14,2	4 090	6 520	370	54	22	
<b>56</b>	12	4 000	212	433	249	551	0,87	0,86	0,04	1,7	3,2	19,3	7 580	5 000	385	46	25	
	24	4 000	242	419	284	533	0,89	0,88	0,07	1,7	3,2	19,3	7 580	5 000	383	46	25	
	36	4 000	258	424	289	501	0,86	0,84	0,07	1,7	3,2	19,3	7 580	5 000	383	46	25	

■ Preferred range

<sup>1)</sup> Standard number of rollers

<sup>2)</sup> Maximum number of rollers on request

<sup>3)</sup> For BRC (backlash eliminated), maximum length can be shorter

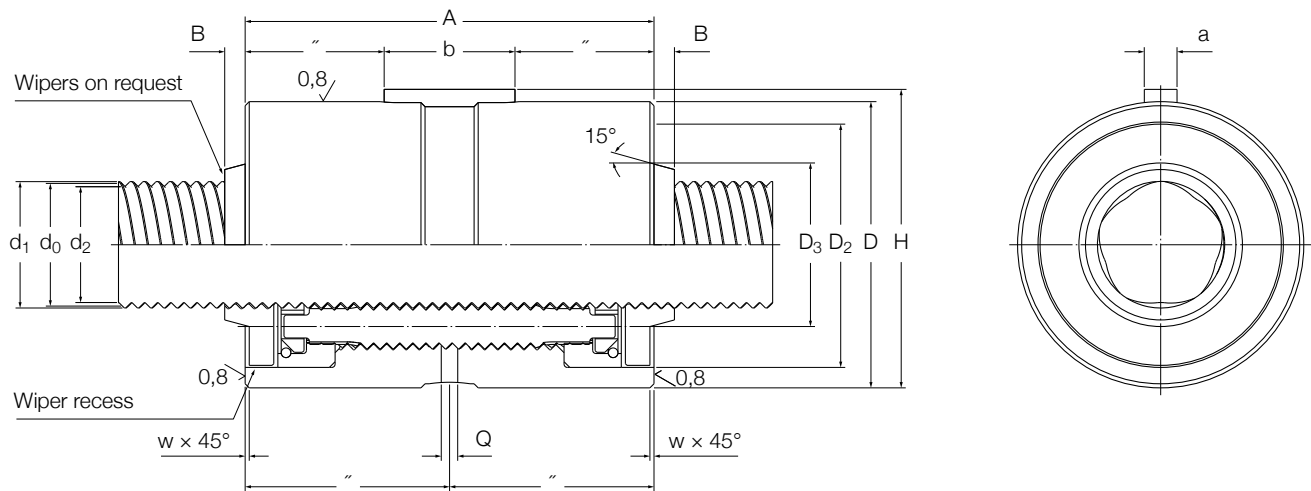

Designation	Dimensions											
	d <sub>1</sub>	d <sub>2</sub>	D	A	w	a	b	H	Q	B	D <sub>2</sub>	D <sub>3</sub>
-	mm											
SRC/BRC 36 x 6	36,4	35,4	68	80	0,5	5	25	70	5	8	62	45
SRC/BRC 36 x 9	36,6	35,1	68	80	0,5	5	25	70	5	8	62	45
SRC/BRC 36 x 12	36,8	34,8	68	80	0,5	5	25	70	5	8	62	45
SRC/BRC 36 x 18	37,2	34,2	68	80	0,5	5	25	70	5	8	62	45
SRC/BRC 36 x 24	37,5	33,6	68	80	0,5	5	25	70	5	8	62	45
SRC/BRC 39 x 5	39,4	38,4	80	100	1	8	40	83	7	8	73	50
SRC/BRC 39 x 10	39,8	37,9	80	100	1	8	40	83	7	8	73	50
SRC/BRC 39 x 15	40,2	37,3	80	100	1	8	40	83	7	8	73	50
SRC/BRC 39 x 20	40,5	36,7	80	100	1	8	40	83	7	8	73	50
SRC/BRC 39 x 25	40,9	36,1	80	100	1	8	40	83	7	8	73	50
SRC/BRC 44 x 8	44,5	43,2	80	90	0,5	6	32	82,5	7	8	74	56
SRC/BRC 44 x 12	44,8	42,8	80	90	0,5	6	32	82,5	7	8	74	56
SRC/BRC 44 x 18	45,2	42,3	80	90	0,5	6	32	82,5	7	8	74	56
SRC/BRC 44 x 24	45,5	41,7	80	90	0,5	6	32	82,5	7	8	74	56
SRC/BRC 44 x 30	45,9	41,1	80	90	0,5	6	32	82,5	7	8	74	56
SRC/BRC 48 x 5	48,4	47,4	100	127	1	8	45	103	7	9	90	60
SRC/BRC 48 x 8	48,6	47,1	100	127	1	8	45	103	7	9	90	60
SRC/BRC 48 x 10	48,8	46,9	100	127	1	8	45	103	7	9	90	60
SRC/BRC 48 x 15	49,2	46,3	100	127	1	8	45	103	7	9	90	60
SRC/BRC 48 x 20	49,5	45,8	100	127	1	8	45	103	7	9	90	60
SRC/BRC 48 x 25	49,9	45,2	100	127	1	8	45	103	7	9	90	60
SRC/BRC 48 x 30	50,3	44,6	100	127	1	8	45	103	7	9	90	60
SRC/BRC 56 x 12	56,8	54,9	100	112	1	8	40	103	7	9	93	66
SRC/BRC 56 x 24	57,5	53,8	100	112	1	8	40	103	7	9	93	66
SRC/BRC 56 x 36	58,3	52,5	100	112	1	8	40	103	7	9	93	66

## SRC/BRC planetary roller screws with cylindrical nut

d 60 – 120 mm



Standard SRC



Threaded rollers



Components assembly

### Dimensions and technical characteristics

d <sub>0</sub>	P <sub>h</sub>	L <sub>tp</sub> <sup>3)</sup>	C <sub>a</sub> <sup>1)</sup>	C <sub>oa</sub> <sup>1)</sup>	C <sub>a</sub> <sup>2)</sup> max	C <sub>oa</sub> <sup>2)</sup> max	η	η'	S <sub>ap</sub>	T <sub>be</sub>	m <sub>n</sub>	m <sub>s</sub>	I <sub>s</sub>	I <sub>nn</sub>	I <sub>ns</sub>	Z <sub>n</sub>	Z <sub>s</sub>
			kN				-		mm	Nm	kg	kg/m	kgmm <sup>2</sup> /m	kgmm <sup>2</sup>		cm <sup>3</sup>	cm <sup>3</sup> /m
<b>60</b>	10	4 250	339	780	387	953	0,86	0,83	0,04	1,9	7,3	22,2	9 990	16 500	1 100	100	27
	15	4 250	373	783	426	957	0,88	0,87	0,07	1,9	7,3	22,2	9 990	16 500	1 100	100	27
	<b>20</b>	<b>4 250</b>	<b>395</b>	<b>786</b>	<b>452</b>	<b>960</b>	<b>0,89</b>	<b>0,88</b>	<b>0,07</b>	<b>1,9</b>	<b>7,3</b>	<b>22,2</b>	<b>9 990</b>	<b>16 400</b>	<b>1 100</b>	<b>100</b>	<b>27</b>
<b>64</b>	12	4 600	-	-	296	763	0,87	0,84	0,04	2,1	5,4	25,3	12 900	10 600	984	46	29
	18	4 600	317	726	333	781	0,89	0,87	0,07	2,1	5,2	25,3	12 900	10 500	914	54	29
	24	4 600	329	690	346	743	0,89	0,88	0,07	2,1	5,2	25,3	12 900	10 500	911	54	29
	30	4 600	318	620	356	733	0,89	0,87	0,07	2,1	4,9	25,3	12 900	10 300	771	69	29
	36	4 600	309	589	346	697	0,88	0,86	0,07	2,1	4,9	25,3	12 900	10 300	771	69	29
<b>75</b>	10	5 500	-	-	505	1 486	0,84	0,80	0,04	-	14,6	34,7	24 400	46 900	4 150	140	33
	15	5 500	-	-	561	1 491	0,87	0,85	0,07	-	14,6	34,7	24 400	46 900	4 150	140	33
	20	5 500	-	-	572	1 496	0,88	0,87	0,07	-	14,6	34,7	24 400	46 900	4 150	140	33
<b>80</b>	10	6 000	365	1 040	383	1 115	0,83	0,79	0,02	-	8,9	39,5	31 600	26 000	2 720	100	36
	18	6 000	420	1 020	441	1 098	0,88	0,86	0,07	-	8,9	39,5	31 600	26 000	2 720	100	36
	24	6 000	452	1 040	474	1 120	0,89	0,87	0,07	-	8,9	39,5	31 600	26 000	2 710	100	36
	42	6 000	398	837	445	989	0,88	0,87	0,07	-	8,9	39,5	31 600	25 200	2 290	130	36
<b>99</b>	20	7 500	-	-	925	3 090	0,87	0,85	0,07	-	36,2	60,4	74 000	207 000	17 500	340	44
	25	7 500	-	-	937	3 096	0,89	0,88	0,07	-	36,2	60,4	74 000	207 000	17 500	340	44
<b>120</b>	20	8 000	-	-	1 131	4 141	0,84	0,81	0,07	-	55,5	88,8	160 000	453 000	40 900	540	53
	25	8 000	-	-	1 127	4 038	0,87	0,85	0,07	-	55,5	88,8	160 000	453 000	40 900	540	53

<sup>1)</sup> Standard number of rollers. Configuration not available for certain sizes

<sup>2)</sup> Maximum number of rollers on request, or standard for certain sizes

<sup>3)</sup> For BRC (backlash eliminated), maximum length can be shorter

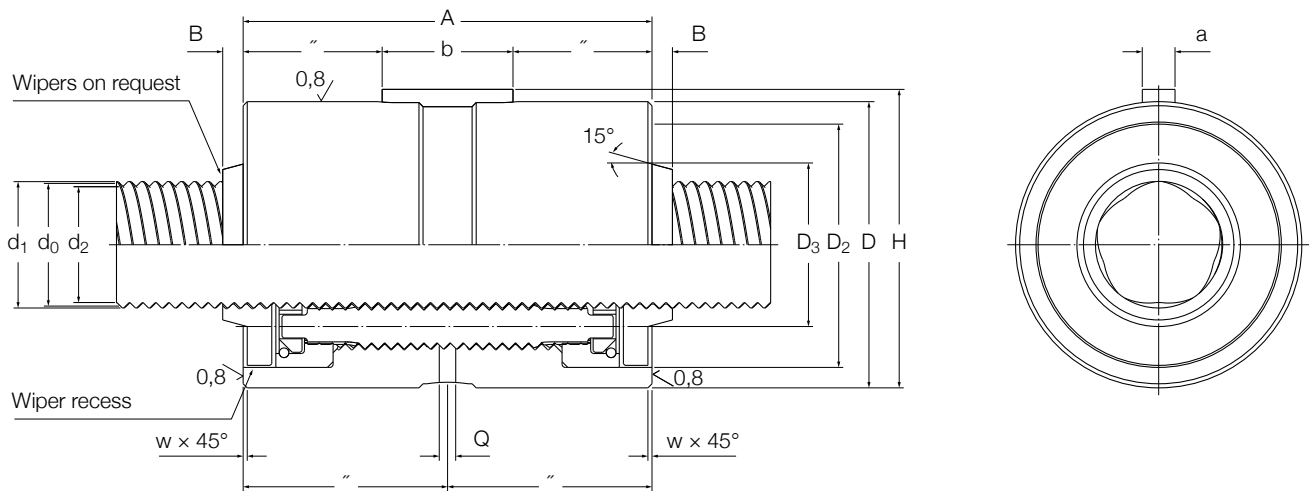

Designation	Dimensions											
	d <sub>1</sub>	d <sub>2</sub>	D	A	w	a	b	H	Q	B	D <sub>2</sub>	D <sub>3</sub>
-	mm											
SRC/BRC 60 x 10	60,8	58,9	122	152	1	10	45	125	10,5	9	110	71
SRC/BRC 60 x 15	61,2	58,4	122	152	1	10	45	125	10,5	9	110	71
SRC/BRC 60 x 20	61,5	57,8	122	152	1	10	45	125	10,5	9	110	71
SRC/BRC 64 x 12	64,8	62,9	115	129	1	8	45	118	7	11	106	75
SRC/BRC 64 x 18	65,2	62,3	115	129	1	8	45	118	7	11	106	75
SRC/BRC 64 x 24	65,5	61,8	115	129	1	8	45	118	7	11	106	75
SRC/BRC 64 x 30	65,9	61,2	115	129	1	8	45	118	7	11	106	75
SRC/BRC 64 x 36	66,3	60,6	115	129	1	8	45	118	7	11	106	75
SRC 75 x 10	75,8	73,9	150	191	1	10	63	153	10,5	10	136	87
SRC 75 x 15	76,2	73,4	150	191	1	10	63	153	10,5	10	136	87
SRC 75 x 20	76,5	72,9	150	191	1	10	63	153	10,5	10	136	87
SRC 80 x 10	80,7	79	140	156	1	10	63	143	10,5	12	132	92
SRC 80 x 18	81,2	78,4	140	156	1	10	63	143	10,5	12	132	92
SRC 80 x 24	81,5	77,8	140	156	1	10	63	143	10,5	12	132	92
SRC 80 x 42	82,7	76,1	140	156	1	10	63	143	10,5	12	132	92
SRC 99 x 20	100,5	96,9	200	260	1,5	16	100	204	15	12	180	112
SRC 99 x 25	100,9	96,3	200	260	1,5	16	100	204	15	12	180	112
SRC 120 x 20	121,5	118	240	280	1,5	16	100	244	15	12	220	180
SRC 120 x 25	121,9	117,4	240	280	1,5	16	100	244	15	12	220	180

## SRF/BRF/SRP/BRP planetary roller screws with flanged nut

d 8 – 30 mm



Standard SRF

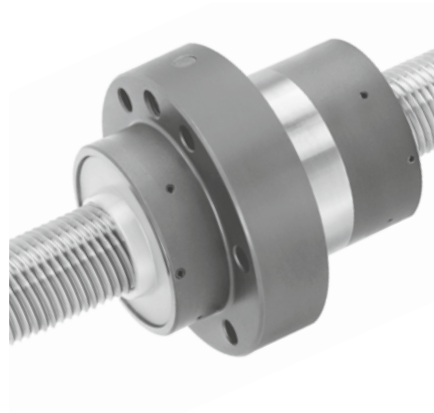

Standard SRP



Threaded rollers

### Dimensions and technical characteristics

d <sub>0</sub>	P <sub>h</sub>	L <sub>p</sub> <sup>3)</sup>	C <sub>a</sub> <sup>1)</sup>	C <sub>oa</sub> <sup>1)</sup>	C <sub>a</sub> <sup>2)</sup> max	C <sub>oa</sub> <sup>2)</sup> max	η	η'	S <sub>ap</sub>	T <sub>be</sub>	m <sub>n</sub>	m <sub>s</sub>	l <sub>s</sub>	l <sub>nn</sub>	l <sub>ns</sub>	Z <sub>n</sub>	Z <sub>s</sub>	
			kN				-		mm	Nm	kg	kg/m	kgmm <sup>2</sup> /m	kgmm <sup>2</sup>			cm <sup>3</sup>	cm <sup>3</sup> /m
<b>8</b>	4	500	-	-	8,93	13,4	0,88	0,87	0,02	0,1	0,3	0,4	3,2	66,4	0,2	0,9	4	
<b>12</b>	5	750	14,1	18,3	15,1	20,4	0,89	0,88	0,02	0,1	0,3	0,9	16	106	0,4	1,4	6	
<b>15</b>	5	975	26	43,6	30	53	0,89	0,88	0,02	0,2	0,5	1,4	39	202	1,2	2,3	7	
	8	975	27,4	40,8	30	45	0,88	0,86	0,02	0,2	0,5	1,4	39	202	1,2	2,3	7	
<b>18</b>	5	1 200	-	-	38	71	0,89	0,87	0,02	0,3	0,6	2	81	244	3	4	8	
	8	1 200	-	-	38	62	0,89	0,87	0,02	0,3	0,6	2	81	244	3	4	8	
<b>21</b>	<b>5</b>	<b>1 400</b>	<b>50,6</b>	<b>82</b>	<b>58</b>	<b>101</b>	<b>0,88</b>	<b>0,86</b>	<b>0,02</b>	<b>0,3</b>	<b>0,7</b>	<b>2,7</b>	<b>150</b>	<b>437</b>	<b>6,5</b>	<b>5,0</b>	<b>10</b>	
	6	1 400	52,8	82,2	60	101	0,89	0,87	0,02	0,3	0,7	2,7	150	437	6,5	5,0	10	
	8	1 400	57	84,1	65	103	0,89	0,88	0,02	0,3	0,7	2,7	150	437	6,5	5,0	10	
	<b>10</b>	<b>1 400</b>	<b>59,2</b>	<b>83</b>	<b>64</b>	<b>92</b>	<b>0,89</b>	<b>0,87</b>	<b>0,04</b>	<b>0,3</b>	<b>0,7</b>	<b>2,7</b>	<b>150</b>	<b>437</b>	<b>6,5</b>	<b>5,0</b>	<b>10</b>	
<b>24</b>	6	1 600	42,3	65,2	47	77	0,88	0,87	0,02	0,4	0,8	3,6	256	525	6,3	4,0	11	
	12	1 600	47,7	62,3	53	74	0,88	0,87	0,04	0,4	0,8	3,6	256	525	6,3	4,0	11	
<b>25</b>	5	1 650	68,4	122	78	149	0,87	0,85	0,02	0,4	1,4	3,9	301	1 200	14	10	11	
	8	1 650	76,1	122	87	149	0,89	0,88	0,02	0,4	1,4	3,9	301	1 200	14	10	11	
	10	1 650	78,6	118	90	145	0,89	0,88	0,04	0,4	1,4	3,9	301	1 200	14	10	11	
	15	1 650	85,6	120	92	133	0,87	0,85	0,07	0,4	1,4	3,9	301	1 200	14	10	11	
<b>30</b>	<b>5</b>	<b>2 000</b>	<b>92</b>	<b>178</b>	<b>106</b>	<b>218</b>	<b>0,86</b>	<b>0,83</b>	<b>0,02</b>	<b>0,6</b>	<b>2,1</b>	<b>5,6</b>	<b>625</b>	<b>2 680</b>	<b>36</b>	<b>14</b>	<b>14</b>	
	6	2 000	95	175	109	215	0,87	0,85	0,02	0,6	2,1	5,6	625	2 680	36	14	14	
	8	2 000	103	178	118	218	0,88	0,87	0,02	0,6	2,1	5,6	625	2 680	36	14	14	
	<b>10</b>	<b>2 000</b>	<b>106</b>	<b>174</b>	<b>122</b>	<b>214</b>	<b>0,89</b>	<b>0,88</b>	<b>0,04</b>	<b>0,6</b>	<b>2,1</b>	<b>5,6</b>	<b>625</b>	<b>2 680</b>	<b>36</b>	<b>14</b>	<b>14</b>	
	15	2 000	119	182	127	201	0,88	0,87	0,07	0,6	2,1	5,6	625	2 680	36	14	14	
	20	2 000	123	177	133	197	0,86	0,83	0,07	0,8	2,1	5,6	625	2 680	36	14	14	

<sup>1)</sup> Standard number of rollers. Configuration not available for certain sizes

<sup>2)</sup> Maximum number of rollers on request, or standard for certain sizes

<sup>3)</sup> For BRC (backlash eliminated), maximum length can be shorter

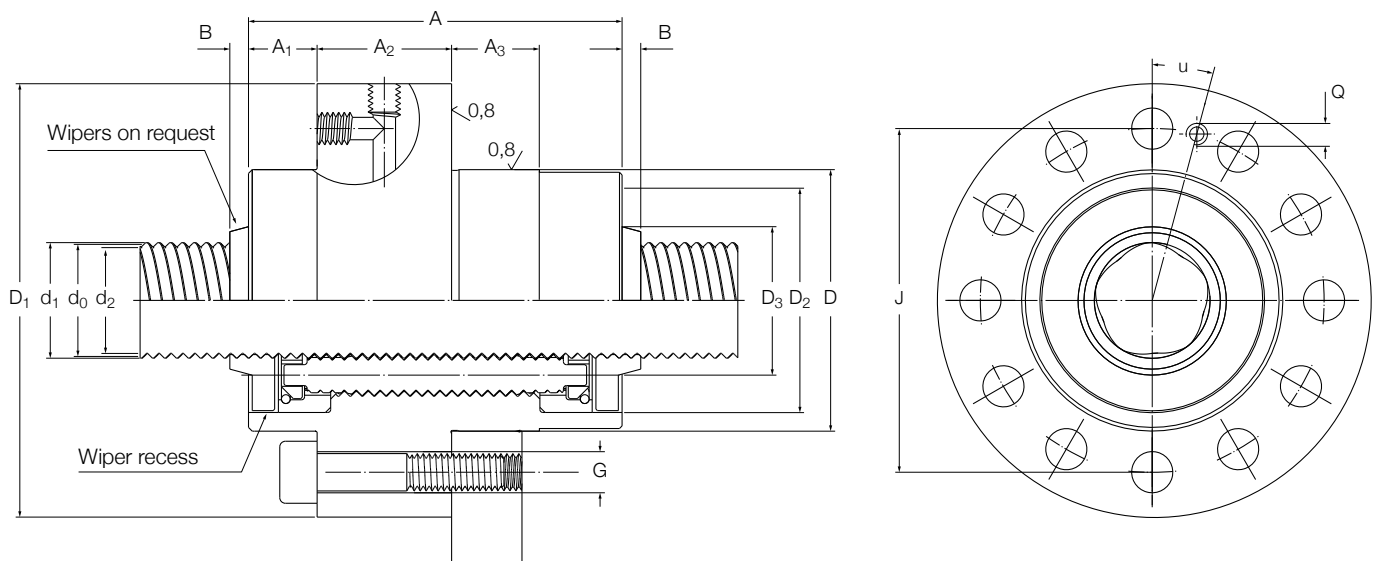

Designation	Dimensions															
	d <sub>1</sub>	d <sub>2</sub>	D	A	A <sub>1</sub>	A <sub>1</sub> <sup>1)</sup>	A <sub>3</sub>	A <sub>2</sub>	D <sub>1</sub>	J	G	Q	B	D <sub>2</sub>	D <sub>3</sub>	u
-	mm															
SRF/BRF 8 x 4	8,4	7,3	25	44	14	-	14	16	46	36	6 x M4	M6	3	21	13	30
SRF/BRF 12 x 5	12,4	11,3	30	44	14	-	14	16	51	41	6 x M4	M6	3	25	17	30
SRF/BRF 15 x 5	15,4	14,3	35	50	16	-	16	18	58	46	6 x M5	M6	3	30	20	30
SRF/BRF 15 x 8	15,6	14	35	50	16	-	16	18	58	46	6 x M5	M6	3	30	20	30
SRF/BRF 18 x 5	18,4	17,3	40	58	20	-	20	18	63	51	6 x M5	M6	3	35	23	30
SRF/BRF 18 x 8	18,6	17	40	58	20	-	20	18	63	51	6 x M5	M6	3	35	23	30
SRF/BRF/SRP/BRP 21 x 5	21,4	20,3	45	64	23	10	10	18	68	56	6 x M5	M6	4	40,5	26	30
SRF/BRF/SRP/BRP 21 x 6	21,5	20,2	45	64	23	10	10	18	68	56	6 x M5	M6	4	40,5	26	30
SRF/BRF/SRP/BRP 21 x 8	21,6	20	45	64	23	10	10	18	68	56	6 x M5	M6	4	40,5	26	30
SRF/BRF/SRP/BRP 21 x 10	21,8	19,8	45	64	23	10	10	18	68	56	6 x M5	M6	4	40,5	26	30
SRF/BRF/SRP/BRP 24 x 6	24,4	23,3	48	58	20	10	10	18	71	59	6 x M5	M6	6	42	31	30
SRF/BRF/SRP/BRP 24 x 12	24,8	22,8	48	58	20	10	10	18	71	59	6 x M5	M6	6	42	31	30
SRF/BRF/SRP/BRP 25 x 5	25,4	24,3	56	78	29	10	10	20	84	70	6 x M6	M6	6	47	32	30
SRF/BRF/SRP/BRP 25 x 8	25,6	24	56	78	29	10	10	20	84	70	6 x M6	M6	6	47	32	30
SRF/BRF/SRP/BRP 25 x 10	25,8	23,8	56	78	29	10	10	20	84	70	6 x M6	M6	6	47	32	30
SRF/BRF/SRP/BRP 25 x 15	26,2	23,2	56	78	29	10	10	20	84	70	6 x M6	M6	6	47	32	30
SRF/BRF/SRP/BRP 30 x 5	30,4	29,4	64	85	29	12	15	27	97	81	6 x M8	M6	7	58	38	30
SRF/BRF/SRP/BRP 30 x 6	30,5	29,3	64	85	29	12	15	27	97	81	6 x M8	M6	7	58	38	30
SRF/BRF/SRP/BRP 30 x 8	30,6	29	64	85	29	12	15	27	97	81	6 x M8	M6	7	58	38	30
SRF/BRF/SRP/BRP 30 x 10	30,8	28,8	64	85	29	12	15	27	97	81	6 x M8	M6	7	58	38	30
SRF/BRF/SRP/BRP 30 x 15	31,2	28,3	64	85	29	12	15	27	97	81	6 x M8	M6	7	58	38	30
SRF/BRF/SRP/BRP 30 x 20	31,5	27,6	64	85	29	12	15	27	97	81	6 x M8	M6	7	58	38	30

<sup>1)</sup> SRP/BRP configuration is not available for screws with nominal diameter d<sub>0</sub> from 8 to 18 mm

## SRF/BRF/SRP/BRP planetary roller screws with flanged nut

d 36 – 56 mm

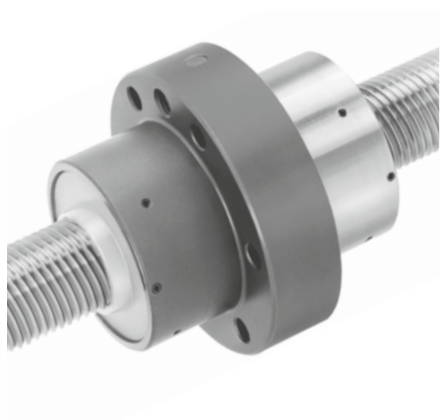

Standard SRF

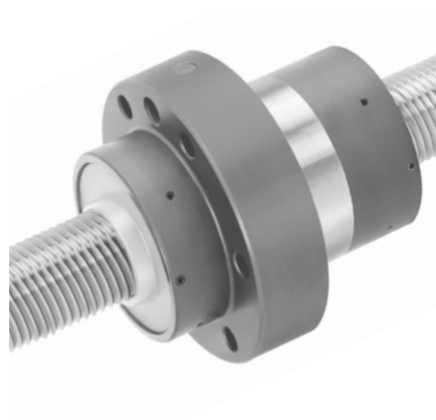

Standard SRP



Threaded rollers

### Dimensions and technical characteristics

d <sub>0</sub>	P <sub>h</sub>	L <sub>p</sub> <sup>3)</sup>	C <sub>a</sub> <sup>1)</sup>	C <sub>oa</sub> <sup>1)</sup>	C <sub>a</sub> <sup>2)</sup> max	C <sub>oa</sub> <sup>2)</sup> max	η	η'	S <sub>ap</sub>	T <sub>be</sub>	m <sub>n</sub>	m <sub>s</sub>	I <sub>s</sub>	I <sub>nn</sub>	I <sub>ns</sub>	Z <sub>n</sub>	Z <sub>s</sub>	
			kN				-		mm	Nm	kg	kg/m	kgmm <sup>2</sup> /m	kgmm <sup>2</sup>			cm <sup>3</sup>	cm <sup>3</sup> /m
<b>36</b>	6	2 400	90,5	179	107	229	0,86	0,83	0,02	0,8	2,2	8	1 290	3 170	46	13	16	
	9	2 400	97,5	174	115	222	0,88	0,87	0,02	0,8	2,2	8	1 290	3 170	46	13	16	
	12	2 400	107	181	126	231	0,89	0,88	0,04	0,8	2,1	8	1 290	3 120	46	13	16	
	18	2 400	114	177	128	209	0,88	0,87	0,07	0,8	2,1	8	1 290	3 120	46	13	16	
	24	2 400	124	184	139	218	0,86	0,83	0,07	0,8	2,1	8	1 290	3 120	46	13	16	
<b>39</b>	<b>5</b>	<b>2 650</b>	<b>129</b>	<b>269</b>	<b>148</b>	<b>329</b>	<b>0,83</b>	<b>0,80</b>	<b>0,02</b>	<b>0,9</b>	<b>4</b>	<b>9,4</b>	<b>1 780</b>	<b>8 360</b>	<b>124</b>	<b>28</b>	<b>18</b>	
	<b>10</b>	<b>2 650</b>	<b>153</b>	<b>271</b>	<b>175</b>	<b>332</b>	<b>0,88</b>	<b>0,87</b>	<b>0,04</b>	<b>0,9</b>	<b>4</b>	<b>9,4</b>	<b>1 780</b>	<b>8 360</b>	<b>124</b>	<b>28</b>	<b>18</b>	
	15	2 650	168	273	192	334	0,89	0,88	0,07	0,9	4	9,4	1 780	8 360	124	28	18	
	20	2 650	173	261	198	319	0,88	0,87	0,07	0,9	4	9,4	1 780	8 360	124	28	18	
	25	2 650	175	249	188	277	0,86	0,84	0,07	0,9	4	9,4	1 780	8 360	124	28	18	
<b>44</b>	8	3 000	130	261	154	333	0,86	0,84	0,02	1,1	3,6	11,9	2 890	8 030	119	23	20	
	12	3 000	144	263	169	335	0,89	0,87	0,04	1,1	3,6	11,9	2 890	8 030	119	23	20	
	18	3 000	158	265	186	338	0,89	0,88	0,07	1,1	3,6	11,9	2 890	8 030	118	23	20	
	24	3 000	168	267	188	316	0,88	0,86	0,07	1,1	3,6	11,9	2 890	8 030	118	23	20	
	30	3 000	166	246	186	292	0,85	0,83	0,07	1,1	3,6	11,9	2 890	8 030	118	23	20	
<b>48</b>	<b>5</b>	<b>3 300</b>	<b>198</b>	<b>482</b>	<b>240</b>	<b>643</b>	<b>0,81</b>	<b>0,76</b>	<b>0,02</b>	<b>1,3</b>	<b>7,8</b>	<b>14,2</b>	<b>4 090</b>	<b>18 500</b>	<b>371</b>	<b>54</b>	<b>22</b>	
	8	3 300	218	471	250	576	0,86	0,83	0,02	1,3	7,8	14,2	4 090	18 500	371	54	22	
	<b>10</b>	<b>3 300</b>	<b>232</b>	<b>475</b>	<b>265</b>	<b>581</b>	<b>0,87</b>	<b>0,85</b>	<b>0,04</b>	<b>1,3</b>	<b>7,8</b>	<b>14,2</b>	<b>4 090</b>	<b>18 500</b>	<b>371</b>	<b>54</b>	<b>22</b>	
	15	3 300	258	486	295	595	0,89	0,88	0,07	1,3	7,8	14,2	4 090	18 500	371	54	22	
	<b>20</b>	<b>3 300</b>	<b>266</b>	<b>462</b>	<b>304</b>	<b>565</b>	<b>0,89</b>	<b>0,88</b>	<b>0,07</b>	<b>1,3</b>	<b>7,8</b>	<b>14,2</b>	<b>4 090</b>	<b>18 500</b>	<b>371</b>	<b>54</b>	<b>22</b>	
	25	3 300	286	491	327	601	0,88	0,87	0,07	1,3	7,8	14,2	4 090	18 500	370	54	22	
<b>56</b>	30	3 300	276	467	316	571	0,87	0,85	0,07	1,3	7,8	14,2	4 090	18 500	370	54	22	
	12	4 000	212	433	250	552	0,87	0,86	0,04	1,7	6,5	19,3	7 580	21 300	385	46	25	
	24	4 000	242	419	285	534	0,89	0,88	0,07	1,7	6,5	19,3	7 580	21 300	383	46	25	
	36	4 000	258	424	289	502	0,86	0,84	0,07	1,7	6,5	19,3	7 580	21 300	383	46	25	

■ Preferred range

<sup>1)</sup> Standard number of rollers

<sup>2)</sup> Maximum number of rollers on request

<sup>3)</sup> For BRC (backlash eliminated), maximum length can be shorter

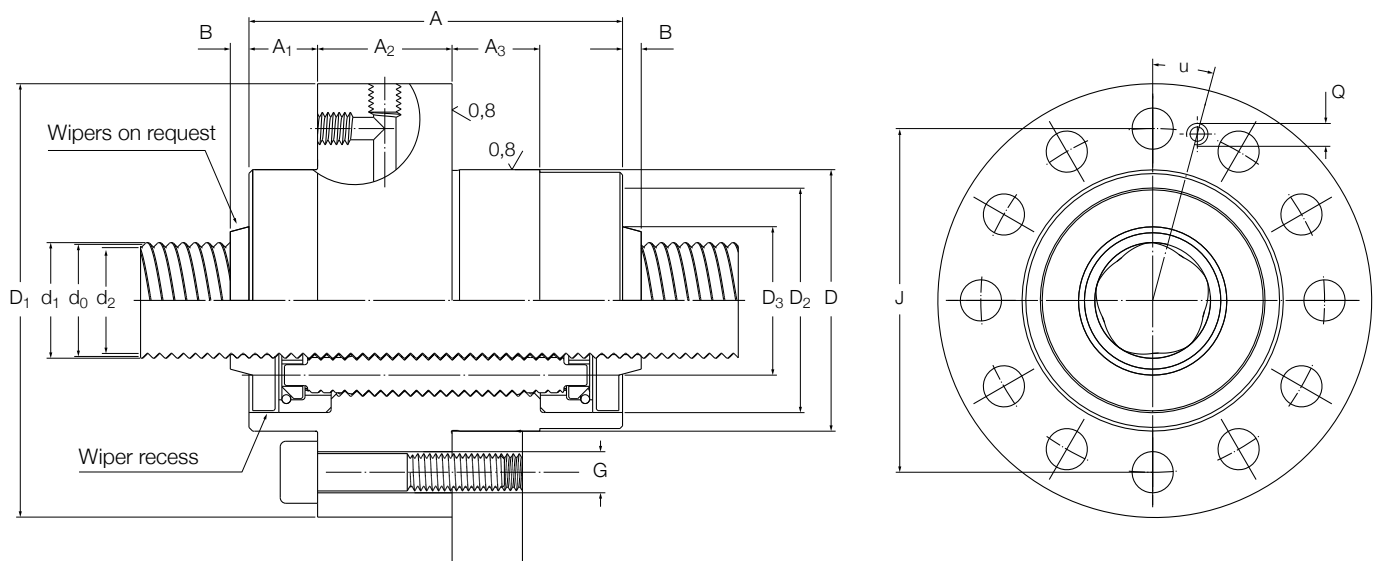

Designation	Dimensions															
	d <sub>1</sub>	d <sub>2</sub>	D	A	A <sub>1</sub>	A <sub>1</sub> <sup>1)</sup>	A <sub>3</sub>	A <sub>2</sub>	D <sub>1</sub>	J	G	Q	B	D <sub>2</sub>	D <sub>3</sub>	u
-	mm															
SRF/BRF/SRP/BRP 36 x 6	36,4	35,4	68	80	26,5	12	15	27	102	85	6 x M8	M6	8	62	45	30
SRF/BRF/SRP/BRP 36 x 9	36,6	35,1	68	80	26,5	12	15	27	102	85	6 x M8	M6	8	62	45	30
SRF/BRF/SRP/BRP 36 x 12	36,8	34,8	68	80	26,5	12	15	27	102	85	6 x M8	M6	8	62	45	30
SRF/BRF/SRP/BRP 36 x 18	37,2	34,2	68	80	26,5	12	15	27	102	85	6 x M8	M6	8	62	45	30
SRF/BRF/SRP/BRP 36 x 24	37,5	33,6	68	80	26,5	12	15	27	102	85	6 x M8	M6	8	62	45	30
SRF/BRF/SRP/BRP 39 x 5	39,4	38,4	82	100	33,5	13	18	33	124	102	6 x M10	M6	8	73	50	30
SRF/BRF/SRP/BRP 39 x 10	39,8	37,9	82	100	33,5	13	18	33	124	102	6 x M10	M6	8	73	50	30
SRF/BRF/SRP/BRP 39 x 15	40,2	37,3	82	100	33,5	13	18	33	124	102	6 x M10	M6	8	73	50	30
SRF/BRF/SRP/BRP 39 x 20	40,5	36,7	82	100	33,5	13	18	33	124	102	6 x M10	M6	8	73	50	30
SRF/BRF/SRP/BRP 39 x 25	40,9	36,1	82	100	33,5	13	18	33	124	102	6 x M10	M6	8	73	50	30
SRF/BRF/SRP/BRP 44 x 8	44,5	43,2	82	90	28,5	12	18	33	124	102	6 x M10	M6	8	74	56	30
SRF/BRF/SRP/BRP 44 x 12	44,8	42,8	82	90	28,5	12	18	33	124	102	6 x M10	M6	8	74	56	30
SRF/BRF/SRP/BRP 44 x 18	45,2	42,3	82	90	28,5	12	18	33	124	102	6 x M10	M6	8	74	56	30
SRF/BRF/SRP/BRP 44 x 24	45,5	41,7	82	90	28,5	12	18	33	124	102	6 x M10	M6	8	74	56	30
SRF/BRF/SRP/BRP 44 x 30	45,9	41,1	82	90	28,5	12	18	33	124	102	6 x M10	M6	8	74	56	30
SRF/BRF/SRP/BRP 48 x 5	48,4	47,4	105	127	45	15	20	37	150	127	6 x M12	M8 x 1 9	90	60	30	
SRF/BRF/SRP/BRP 48 x 8	48,6	47,1	105	127	45	15	20	37	150	127	6 x M12	M8 x 1 9	90	60	30	
SRF/BRF/SRP/BRP 48 x 10	48,8	46,9	105	127	45	15	20	37	150	127	6 x M12	M8 x 1 9	90	60	30	
SRF/BRF/SRP/BRP 48 x 15	49,2	46,3	105	127	45	15	20	37	150	127	6 x M12	M8 x 1 9	90	60	30	
SRF/BRF/SRP/BRP 48 x 20	49,5	45,8	105	127	45	15	20	37	150	127	6 x M12	M8 x 1 9	90	60	30	
SRF/BRF/SRP/BRP 48 x 25	49,9	45,2	105	127	45	15	20	37	150	127	6 x M12	M8 x 1 9	90	60	30	
SRF/BRF/SRP/BRP 48 x 30	50,3	44,6	105	127	45	15	20	37	150	127	6 x M12	M8 x 1 9	90	60	30	
SRF/BRF/SRP/BRP 56 x 12	56,8	54,9	105	112	37,5	15	20	37	150	127	6 x M12	M8 x 1 9	93	66	30	
SRF/BRF/SRP/BRP 56 x 24	57,5	53,8	105	112	37,5	15	20	37	150	127	6 x M12	M8 x 1 9	93	66	30	
SRF/BRF/SRP/BRP 56 x 36	58,3	52,5	105	112	37,5	15	20	37	150	127	6 x M12	M8 x 1 9	93	66	30	

SRF/BRF/SRP/BRP planetary roller screws with flanged nut

d 60 – 120 mm



Standard SRF

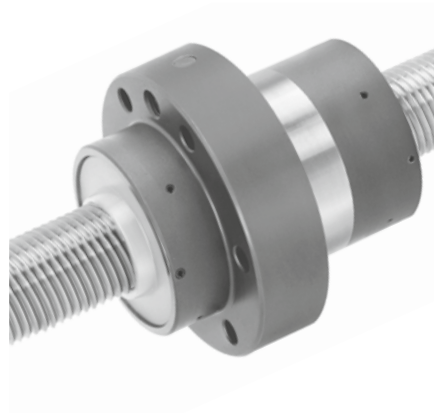

Standard SRP



Threaded rollers

Dimensions and technical characteristics

d <sub>0</sub>	P <sub>h</sub>	L <sub>p</sub> <sup>3)</sup>	C <sub>a</sub> <sup>1)</sup>	C <sub>oa</sub> <sup>1)</sup>	C <sub>a</sub> <sup>2)</sup> max	C <sub>oa</sub> <sup>2)</sup> max	η	η'	S <sub>ap</sub>	T <sub>be</sub>	m <sub>n</sub>	m <sub>s</sub>	I <sub>s</sub>	I <sub>nn</sub>	I <sub>ns</sub>	Z <sub>n</sub>	Z <sub>s</sub>
			kN				-		mm	Nm	kg	kg/m	kgmm <sup>2</sup> /m	kgmm <sup>2</sup>		cm <sup>3</sup>	cm <sup>3</sup> /m
60	10	4 250	339	780	388	953	0,86	0,83	0,04	1,9	12,1	22,2	9 990	52 800	1 100	100	27
	15	4 250	373	783	427	957	0,88	0,87	0,07	1,9	12,1	22,2	9 990	52 800	1 100	100	27
	20	4 250	395	786	452	961	0,89	0,88	0,07	1,9	12,1	22,2	9 990	52 800	1 100	100	27
64	12	4 600	-	-	297	764	0,87	0,84	0,04	2,1	11,3	25,3	12 900	50 200	984	46	29
	18	4 600	317	726	333	782	0,89	0,87	0,07	2,1	11,2	25,3	12 900	50 100	914	54	29
	24	4 600	329	690	346	743	0,89	0,88	0,07	2,1	11,2	25,3	12 900	50 100	911	54	29
	30	4 600	318	620	356	733	0,89	0,87	0,07	2,1	10,9	25,3	12 900	49 900	771	69	29
	36	4 600	309	589	346	697	0,88	0,86	0,07	2,1	10,9	25,3	12 900	49 900	771	69	29
75	10	5 500	-	-	505	1 486	0,84	0,8	0,04	-	20,6	34,7	24 400	114 000	4 150	140	33
	15	5 500	-	-	561	1 491	0,87	0,85	0,07	-	20,6	34,7	24 400	114 000	4 150	140	33
	20	5 500	-	-	572	1 496	0,88	0,87	0,07	-	20,6	34,7	24 400	114 000	4 150	140	33
80	10	6 000	365	1 040	384	1 115	0,83	0,79	0,02	-	17,7	39,5	31 600	108 000	2 720	100	36
	18	6 000	420	1 020	442	1 099	0,88	0,86	0,07	-	17,7	39,5	31 600	108 000	2 720	100	36
	24	6 000	452	1 040	475	1 121	0,89	0,87	0,07	-	17,7	39,5	31 600	108 000	2 710	100	36
	42	6 000	398	837	445	989	0,88	0,87	0,07	-	17,7	39,5	31 600	108 000	2 290	130	36
99	20	7 500	-	-	925	3 091	0,87	0,85	0,07	-	48,3	60,4	74 000	449 000	17 500	340	44
	25	7 500	-	-	937	3 096	0,89	0,88	0,07	-	48,3	60,4	74 000	449 000	17 500	340	44
120	20	8 000	-	-	1 131	4 041	0,84	0,81	0,07	-	89	88,8	160 000	1,29 x 106	40 900	540	53
	25	8 000	-	-	1 127	4 038	0,87	0,85	0,07	-	89	88,8	160 000	1,29 x 106	40 900	540	53

<sup>1)</sup> Standard number of rollers. Configuration not available for certain sizes

<sup>2)</sup> Maximum number of rollers on request, or standard for certain sizes

<sup>3)</sup> For BRC (backlash eliminated), maximum length can be shorter

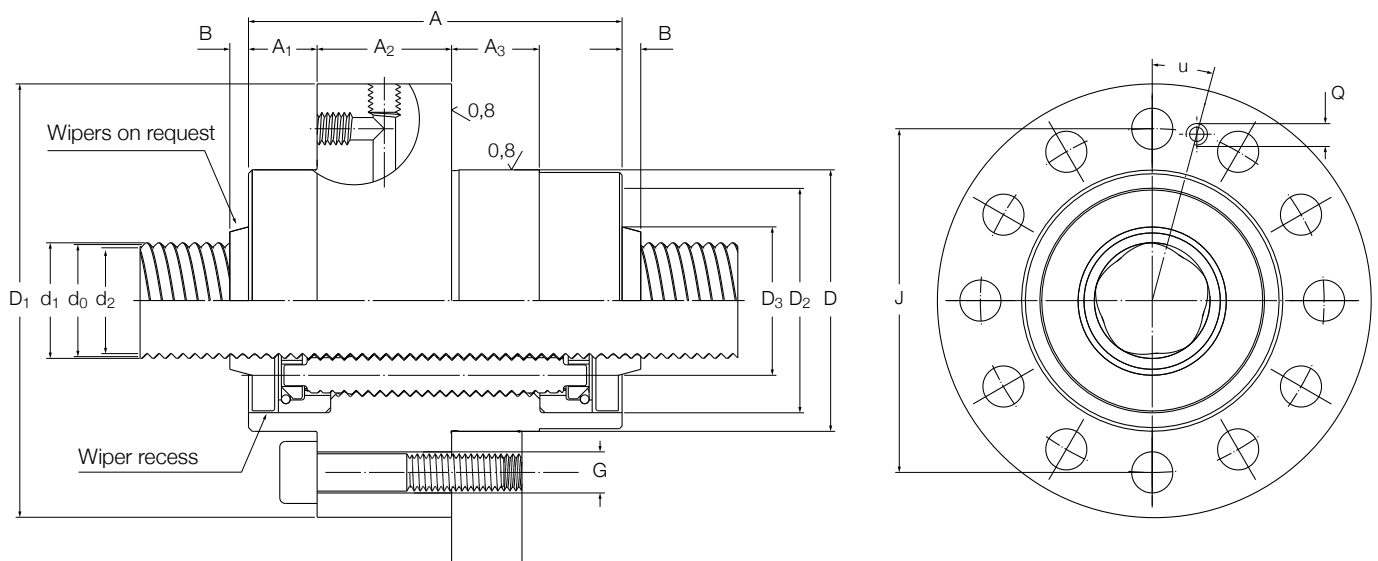

Designation	Dimensions															
	d <sub>1</sub>	d <sub>2</sub>	D	A	A <sub>1</sub>	A <sub>1</sub> <sup>1)</sup>	A <sub>3</sub>	A <sub>2</sub>	D <sub>1</sub>	J	G	Q	B	D <sub>2</sub>	D <sub>3</sub>	u
-	mm															
<b>SRF/BRF/SRP/BRP 60 x 10</b>	60,8	58,9	122	152	53,5	17	25	45	180	150	6 x M16	M8 x 1	9	110	71	30
<b>SRF/BRF/SRP/BRP 60 x 15</b>	61,2	58,4	122	152	53,5	17	25	45	180	150	6 x M16	M8 x 1	9	110	71	30
<b>SRF/BRF/SRP/BRP 60 x 20</b>	<b>61,5</b>	<b>57,8</b>	<b>122</b>	<b>152</b>	<b>53,5</b>	<b>17</b>	<b>25</b>	<b>45</b>	<b>180</b>	<b>150</b>	<b>6 x M16</b>	<b>M8 x 1</b>	<b>9</b>	<b>110</b>	<b>71</b>	<b>30</b>
<b>SRF/BRF/SRP/BRP 64 x 12</b>	64,8	62,9	120	129	42	17	25	45	180	150	6 x M16	M8 x 1	11	106	75	30
<b>SRF/BRF/SRP/BRP 64 x 18</b>	65,2	62,3	120	129	42	17	25	45	180	150	6 x M16	M8 x 1	11	106	75	30
<b>SRF/BRF/SRP/BRP 64 x 24</b>	65,5	61,8	120	129	42	17	25	45	180	150	6 x M16	M8 x 1	11	106	75	30
<b>SRF/BRF/SRP/BRP 64 x 30</b>	65,9	61,2	120	129	42	17	25	45	180	150	6 x M16	M8 x 1	11	106	75	30
<b>SRF/BRF/SRP/BRP 64 x 36</b>	66,3	60,6	120	129	42	17	25	45	180	150	6 x M16	M8 x 1	11	106	75	30
<b>SRF/SRP 75 x 10</b>	75,8	73,9	150	191	73	21	35	45	210	180	8 x M16	M8 x 1	10	136	87	22,5
<b>SRF/SRP 75 x 15</b>	76,2	73,4	150	191	73	21	35	45	210	180	8 x M16	M8 x 1	10	136	87	22,5
<b>SRF/SRP 75 x 20</b>	76,5	72,9	150	191	73	21	35	45	210	180	8 x M16	M8 x 1	10	136	87	22,5
<b>SRF/SRP 80 x 10</b>	80,7	79	150	156	55,5	19	35	45	210	180	8 x M16	M8 x 1	12	132	92	22,5
<b>SRF/SRP 80 x 18</b>	81,2	78,4	150	156	55,5	19	35	45	210	180	8 x M16	M8 x 1	12	132	92	22,5
<b>SRF/SRP 80 x 24</b>	81,5	77,8	150	156	55,5	19	35	45	210	180	8 x M16	M8 x 1	12	132	92	22,5
<b>SRF/SRP 80 x 42</b>	82,7	76,1	150	156	55,5	19	35	45	210	180	8 x M16	M8 x 1	12	132	92	22,5
<b>SRF/SRP 99 x 20</b>	100,5	96,9	200	260	102,5	26	40	55	275	245	12 x M16	M8 x 1	12	180	112	15
<b>SRF/SRP 99 x 25</b>	100,9	96,3	200	260	102,5	26	40	55	275	245	12 x M16	M8 x 1	12	180	112	15
<b>SRF/SRP 120 x 20</b>	121,5	118	260	280	112,5	27	60	55	340	305	12 x M16	M12 x 1,75	12	220	180	15
<b>SRF/SRP 120 x 25</b>	121,9	117,4	260	280	112,5	27	60	55	340	305	12 x M16	M12 x 1,75	12	220	180	15

PRU preloaded planetary roller screws with cylindrical nut

d 8 – 30 mm



Standard PRU



Threaded rollers



Components assembly

Dimensions and technical characteristics

d <sub>0</sub>	P <sub>h</sub>	L <sub>tp</sub>	C <sub>a</sub> <sup>1)</sup>	C <sub>oa</sub> <sup>1)</sup>	C <sub>a</sub> <sup>2)</sup> max	C <sub>oa</sub> <sup>2)</sup> max	η	η'	R <sub>ng</sub>	R <sub>nr</sub>	T <sub>pr</sub>	F <sub>pr</sub>	m <sub>n</sub>	m <sub>s</sub>	l <sub>s</sub>	l <sub>nn</sub>	l <sub>ns</sub>	Z <sub>n</sub>	Z <sub>s</sub>
			kN				-		N/μm		Nm	N	kg	kg/m	kgmm <sup>2</sup> /m	kgmm <sup>2</sup>		cm <sup>3</sup>	cm <sup>3</sup> /m
8	2	400	-	-	4,74	7,98	0,88	0,87	173	193	0,1	602	0,1	0,4	3,2	11,4	0,1	0,8	4
	4	400	-	-	4,92	6,72	0,88	0,87	110	150	0,1	236	0,1	0,4	3,2	11,4	0,1	0,9	4
12	2	600	-	-	7,25	11,2	0,86	0,83	249	298	0,2	1 007	0,2	0,9	16	22,9	0,4	1,1	6
	5	600	7,76	9,17	8,32	10,2	0,89	0,88	180	240	0,2	570	0,2	0,9	16	22,9	0,4	1,4	6
15	2	750	-	-	13,1	26,4	0,84	0,80	498	565	0,3	1 211	0,2	1,4	39	45,2	1,2	1,9	7
	5	750	14,3	21,8	16,4	26,6	0,89	0,88	290	380	0,3	932	0,2	1,4	39	45,2	1,2	2,3	7
	8	750	15,1	20,4	16,2	22,7	0,88	0,86	242	315	0,3	954	0,2	1,4	39	45,2	1,2	2,3	7
18	2	900	-	-	16,8	35,5	0,82	0,77	529	644	0,4	1 500	0,36	2	81	81	3	4,0	8
	5	900	-	-	20,8	35,5	0,89	0,87	348	385	0,4	1 078	0,35	2	81	81	3	4,0	8
	8	900	-	-	20,9	30,8	0,89	0,87	202	224	0,4	630	0,35	2	81	81	3	4,0	8
21	2	1 100	-	-	26,1	51,6	0,80	0,74	675	762	0,5	1 740	0,4	2,7	150	141	6,5	5,0	10
	5	1 100	27,9	41	31,8	50,1	0,88	0,86	400	520	0,5	1 341	0,4	2,7	150	141	6,5	5,0	10
	6	1 100	29,1	41,1	33,2	50,2	0,89	0,87	359	467	0,5	1 394	0,4	2,7	150	141	6,5	5,0	10
	8	1 100	31,4	42,1	35,9	51,4	0,89	0,88	311	404	0,5	1 354	0,4	2,7	150	141	6,5	5,0	10
	10	1 100	32,6	41,5	35	46,1	0,89	0,87	200	260	0,5	557	0,4	2,7	150	141	6,5	5,0	10
24	6	1 250	23,3	32,6	26,1	38,5	0,88	0,87	370	490	0,6	1 597	0,5	3,6	256	173	6,3	4,0	11
	12	1 250	26,3	31,2	29,4	36,8	0,88	0,87	150	200	0,6	541	0,5	3,6	256	173	6,3	4,0	11
25	5	1 300	37,7	60,9	43,1	74,4	0,87	0,85	460	600	0,6	1 577	0,7	3,9	301	322	14,3	10	11
	8	1 300	41,9	60,8	47,9	74,3	0,89	0,88	347	385	0,6	1 335	0,7	3,9	301	322	14,3	10	11
	10	1 300	43,3	59,2	49,5	72,4	0,89	0,88	290	380	0,6	1 008	0,7	3,9	301	322	14,3	10	11
	15	1 300	47,2	59,8	50,6	66,5	0,87	0,85	180	230	0,6	426	0,7	3,9	301	322	14,3	10	11
30	5	1 600	50,7	89,2	57,9	109	0,86	0,83	620	810	0,9	1 844	1,2	5,6	624	762	36,2	14	14
	6	1 600	52,3	87,7	59,8	107	0,87	0,85	561	729	0,9	1 780	1,2	5,6	624	762	36,2	14	14
	8	1 600	56,5	89,1	64,6	109	0,88	0,87	489	544	0,9	1 629	1,2	5,6	624	762	36,2	14	14
	10	1 600	58,6	87,2	67	107	0,89	0,88	420	550	0,9	1 472	1,2	5,6	624	762	36,2	14	14
	15	1 600	65,4	90,7	70,1	101	0,88	0,87	280	311	0,9	601	1,2	5,6	624	762	35,9	14	14
	20	1 600	67,9	88,6	72,9	98,5	0,86	0,83	190	260	1,1	555	1,2	5,6	624	762	35,9	14	14

<sup>1)</sup> Standard number of rollers. Configuration not available for certain sizes

<sup>2)</sup> Maximum number of rollers on request, or standard for certain sizes

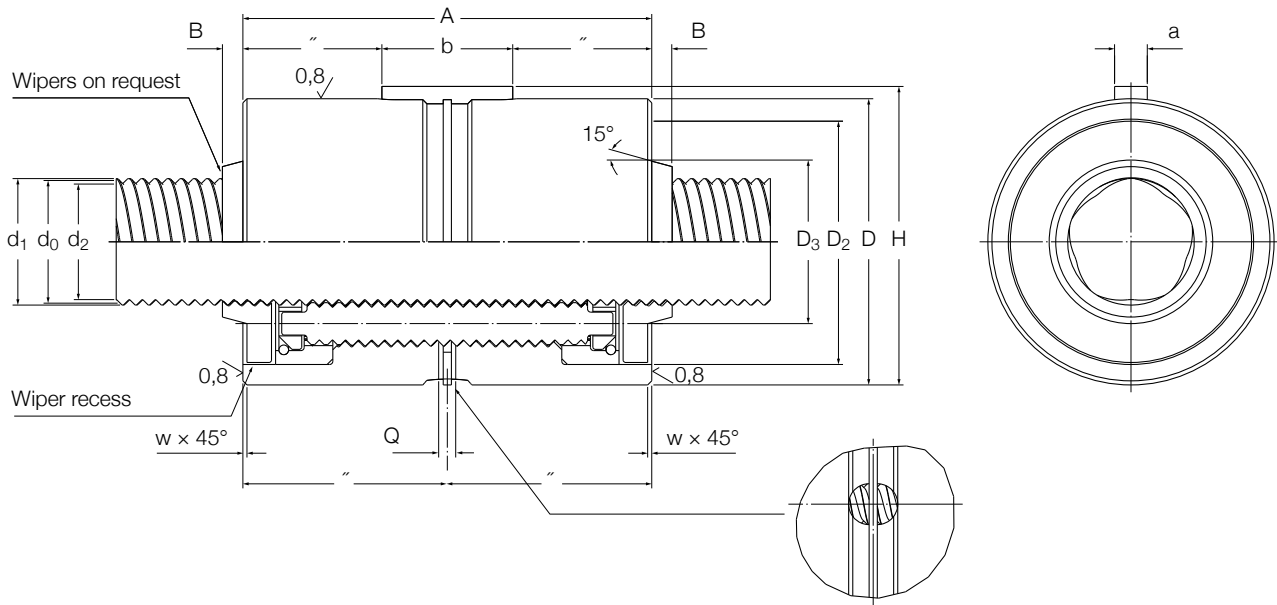

Designation	Dimensions											
	d <sub>1</sub>	d <sub>2</sub>	D g6/H7	A h12	w	a h9	b	H	Q	B	D <sub>2</sub>	D <sub>3</sub>
-	mm											
PRU 8 x 2	8,2	7,6	25	44	0,5	4	12	26,5	5	3	21	13
PRU 8 x 4	8,4	7,3	25	44	0,5	4	12	26,5	5	3	21	13
PRU 12 x 2	12,2	11,6	30	44	0,5	4	12	31,5	5	3	25	17
PRU 12 x 5	12,4	11,3	30	44	0,5	4	12	31,5	5	3	25	17
PRU 15 x 2	15,2	14,6	35	50	0,5	4	16	36,5	5	3	30	20
PRU 15 x 5	15,4	14,3	35	50	0,5	4	16	36,5	5	3	30	20
PRU 15 x 8	15,6	14	35	50	0,5	4	16	36,5	5	3	30	20
PRU 18 x 2	18,2	17,6	40	58	0,5	5	18	42	5	3	35	23
PRU 18 x 5	18,4	17,3	40	58	0,5	5	18	42	5	3	35	23
PRU 18 x 8	18,6	17,0	40	58	0,5	5	18	42	5	3	35	23
PRU 21 x 2	21,2	20,6	45	64	0,5	5	20	47	5	4	40,5	26
PRU 21 x 5	21,4	20,3	45	64	0,5	5	20	47	5	4	40,5	26
PRU 21 x 6	21,5	20,2	45	64	0,5	5	20	47	5	4	40,5	26
PRU 21 x 8	21,6	20	45	64	0,5	5	20	47	5	4	40,5	26
PRU 21 x 10	21,8	19,8	45	64	0,5	5	20	47	5	4	40,5	26
PRU 24 x 6	24,4	23,3	48	58	0,5	5	20	50	5	6	42	31
PRU 24 x 12	24,8	22,8	48	58	0,5	5	20	50	5	6	42	31
PRU 25 x 5	25,4	24,3	53	78	0,5	6	25	55,5	5	6	47	32
PRU 25 x 8	25,6	24,0	53	78	0,5	6	25	55,5	5	6	47	32
PRU 25 x 10	25,8	23,8	53	78	0,5	6	25	55,5	5	6	47	32
PRU 25 x 15	26,2	23,2	53	78	0,5	6	25	55,5	5	6	47	32
PRU 30 x 5	30,4	29,4	64	85	0,5	6	32	66,5	5	7	58	38
PRU 30 x 6	30,5	29,3	64	85	0,5	6	32	66,5	5	7	58	38
PRU 30 x 8	30,6	29	64	85	0,5	6	32	66,5	5	7	58	38
PRU 30 x 10	30,8	28,8	64	85	0,5	6	32	66,5	5	7	58	38
PRU 30 x 15	31,2	28,3	64	85	0,5	6	32	66,5	5	7	58	38
PRU 30 x 20	31,5	27,6	64	85	0,5	6	32	66,5	5	7	58	38

## PRU preloaded planetary roller screws with cylindrical nut

d 36 – 56 mm



Standard PRU



Threaded rollers



Components assembly

### Dimensions and technical characteristics

d <sub>0</sub>	P <sub>h</sub>	L <sub>tp</sub>	C <sub>a</sub> <sup>1)</sup>	C <sub>oa</sub> <sup>1)</sup>	C <sub>a</sub> <sup>2)</sup> max	C <sub>oa</sub> <sup>2)</sup> max	η	η'	R <sub>ng</sub>	R <sub>nr</sub>	T <sub>pr</sub>	F <sub>pr</sub>	m <sub>n</sub>	m <sub>s</sub>	l <sub>s</sub>	l <sub>nn</sub>	l <sub>ns</sub>	Z <sub>n</sub>	Z <sub>s</sub>
mm			kN				-		N/μm		Nm	N	kg	kg/m	kgmm <sup>2</sup> /m	kgmm <sup>2</sup>		cm <sup>3</sup>	cm <sup>3</sup> /m
<b>36</b>	6	1 900	49,8	89,7	58,5	114	0,86	0,83	770	1 000	1,2	2 334	1,2	8	1 290	823	45,7	13	16
	9	1 900	53,7	87	63,1	111	0,88	0,87	530	689	1,2	1 960	1,2	8	1 290	823	45,7	13	16
	12	1 900	58,7	90,6	69	115	0,89	0,88	510	660	1,2	1 820	1,2	8	1 290	823	45,7	13	16
	18	1 900	62,9	88,3	70,3	104	0,88	0,87	260	330	1,2	707	1,2	8	1 290	823	45,7	13	16
	24	1 900	68,1	92,2	76,1	109	0,86	0,83	240	310	1,5	649	1,2	8	1 290	823	45,7	13	16
<b>39</b>	5	2 100	71,2	134	81,4	164	0,83	0,80	750	980	1,3	2 288	2,1	9,4	1 780	2 030	124	28	18
	10	2 100	84,1	135	96,1	166	0,88	0,87	500	650	1,3	1 965	2,1	9,4	1 780	2 030	124	28	18
	15	2 100	92,4	136	106	167	0,89	0,88	390	510	1,3	1 465	2,1	9,4	1 780	2 030	124	28	18
	20	2 100	95,2	130	109	159	0,88	0,87	220	290	1,3	694	2,1	9,4	1 780	2 030	124	28	18
	25	2 100	96,3	125	103	138	0,86	0,84	210	280	1,8	697	2,1	9,4	1 780	2 030	124	28	18
<b>44</b>	8	2 400	71,9	131	84,4	166	0,86	0,84	688	895	1,6	2 432	1,7	11,9	2 890	1 730	119	23	20
	12	2 400	79,2	131	93	167	0,89	0,87	610	800	1,6	2 297	1,7	11,9	2 890	1 730	119	23	20
	18	2 400	86,9	132	102	169	0,89	0,88	430	550	1,6	1 497	1,7	11,9	2 890	1 730	118	23	20
	24	2 400	92,5	133	103	158	0,88	0,86	290	380	1,6	725	1,7	11,9	2 890	1 730	118	23	20
	30	2 400	91,4	123	102	146	0,85	0,83	190	250	2,1	727	1,7	11,9	2 890	1 730	118	23	20
<b>48</b>	5	2 600	109	241	132	321	0,81	0,76	1 080	1 410	1,9	2 698	4,2	14,2	4 090	6 520	371	54	22
	8	2 600	120	235	138	288	0,86	0,83	889	1 156	1,9	2 583	4,2	14,2	4 090	6 520	371	54	22
	10	2 600	128	238	146	290	0,87	0,85	760	980	1,9	2 405	4,2	14,2	4 090	6 520	371	54	22
	15	2 600	142	243	162	297	0,89	0,88	600	780	1,9	2 072	4,2	14,2	4 090	6 520	371	54	22
	20	2 600	146	231	167	283	0,89	0,88	460	600	1,9	1 423	4,2	14,2	4 090	6 520	371	54	22
	25	2 600	157	246	180	300	0,88	0,87	320	480	1,9	782	4,2	14,2	4 090	6 520	370	54	22
<b>56</b>	30	2 600	152	233	174	285	0,87	0,85	344	384	2,5	1 260	4,2	14,2	4 090	6 520	370	54	22
	12	3 100	117	217	137	276	0,87	0,86	810	1 060	2,4	2 952	3,2	19,3	7 580	5 000	385	46	25
	24	3 100	133	210	157	267	0,89	0,88	410	530	2,4	1 579	3,2	19,3	7 580	5 000	383	46	25
	36	3 100	142	212	159	251	0,86	0,84	290	370	3,2	910	3,2	19,3	7 580	5 000	383	46	25

<sup>1)</sup> Standard number of rollers

<sup>2)</sup> Maximum number of rollers on request

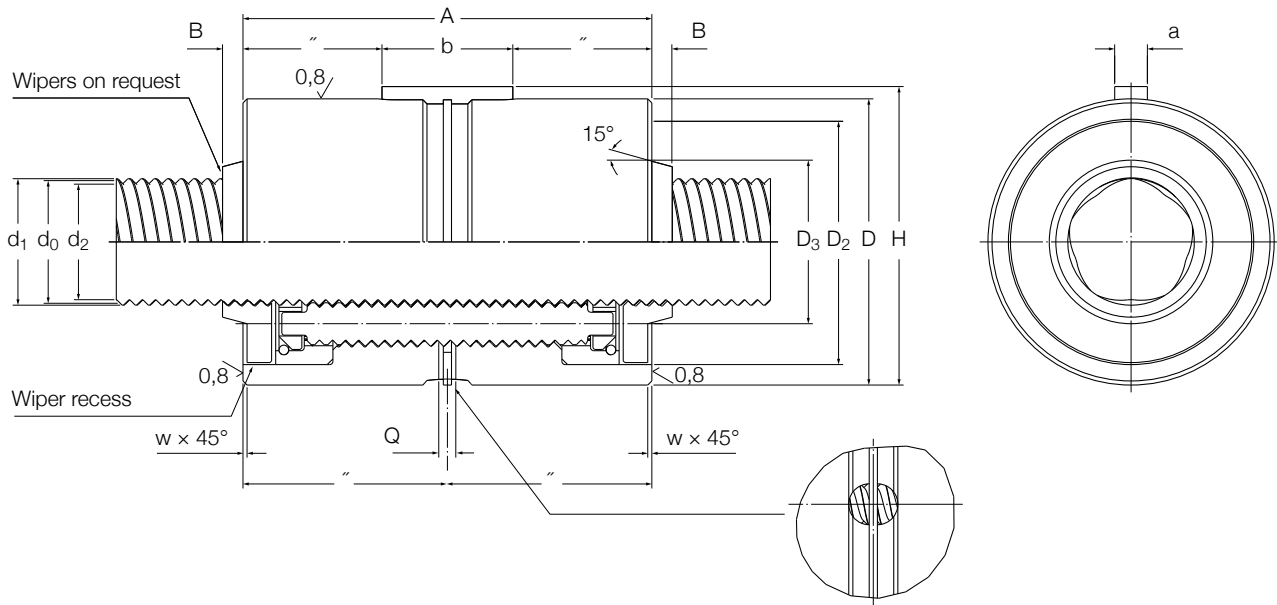

Designation	Dimensions											
	d <sub>1</sub>	d <sub>2</sub>	D g6/H7	A h12	w	a h9	b	H	Q	B	D <sub>2</sub>	D <sub>3</sub>
-	mm											
<b>PRU 36 x 6</b>	36,4	35,4	68	80	0,5	5	25	70	5	8	62	45
<b>PRU 36 x 9</b>	36,6	35,1	68	80	0,5	5	25	70	5	8	62	45
<b>PRU 36 x 12</b>	36,8	34,8	68	80	0,5	5	25	70	5	8	62	45
<b>PRU 36 x 18</b>	37,2	34,2	68	80	0,5	5	25	70	5	8	62	45
<b>PRU 36 x 24</b>	37,5	33,6	68	80	0,5	5	25	70	5	8	62	45
<b>PRU 39 x 5</b>	39,4	38,4	80	100	1	8	40	83	7	8	73	50
<b>PRU 39 x 10</b>	39,8	37,9	80	100	1	8	40	83	7	8	73	50
<b>PRU 39 x 15</b>	40,2	37,3	80	100	1	8	40	83	7	8	73	50
<b>PRU 39 x 20</b>	40,5	36,7	80	100	1	8	40	83	7	8	73	50
<b>PRU 39 x 25</b>	40,9	36,1	80	100	1	8	40	83	7	8	73	50
<b>PRU 44 x 8</b>	44,5	43,2	80	90	0,5	6	32	82,5	7	8	74	56
<b>PRU 44 x 12</b>	44,8	42,8	80	90	0,5	6	32	82,5	7	8	74	56
<b>PRU 44 x 18</b>	45,2	42,3	80	90	0,5	6	32	82,5	7	8	74	56
<b>PRU 44 x 24</b>	45,5	41,7	80	90	0,5	6	32	82,5	7	8	74	56
<b>PRU 44 x 30</b>	45,9	41,1	80	90	0,5	6	32	82,5	7	8	74	56
<b>PRU 48 x 5</b>	48,4	47,4	100	127	1	8	45	103	7	9	90	60
<b>PRU 48 x 8</b>	48,6	47,1	100	127	1	8	45	103	7	9	90	60
<b>PRU 48 x 10</b>	48,8	46,9	100	127	1	8	45	103	7	9	90	60
<b>PRU 48 x 15</b>	49,2	46,3	100	127	1	8	45	103	7	9	90	60
<b>PRU 48 x 20</b>	49,5	45,8	100	127	1	8	45	103	7	9	90	60
<b>PRU 48 x 25</b>	49,9	45,2	100	127	1	8	45	103	7	9	90	60
<b>PRU 48 x 30</b>	50,3	44,6	100	127	1	8	45	103	7	9	90	60
<b>PRU 56 x 12</b>	56,8	54,9	100	112	1	8	40	103	7	9	93	66
<b>PRU 56 x 24</b>	57,5	53,8	100	112	1	8	40	103	7	9	93	66
<b>PRU 56 x 36</b>	58,3	52,5	100	112	1	8	40	103	7	9	93	66

## PRU preloaded planetary roller screws with cylindrical nut

d 60 – 64 mm



Standard PRU



Threaded rollers



Components assembly

### Dimensions and technical characteristics

$d_0$	$P_h$	$L_{tp}$	$C_a^{1)}$	$C_{oa}^{1)}$	$C_a^{2)}$ max	$C_{oa}^{2)}$ max	$\eta$	$\eta'$	$R_{ng}$	$R_{nr}$	$T_{pr}$	$F_{pr}$	$m_n$	$m_s$	$l_s$	$l_{nn}$	$l_{ns}$	$Z_n$	$Z_s$
mm			kN				-		N/ $\mu$ m		Nm	N	kg	kg/m	kgmm <sup>2</sup> /m	kgmm <sup>2</sup>		cm <sup>3</sup>	cm <sup>3</sup> /m
60	10	3 400	187	390	213	476	0,86	0,83	1 030	1 340	2,7	2 913	7,3	22,2	9 990	16 500	1 100	100	27
	15	3 400	206	391	235	478	0,88	0,87	830	1 080	2,7	2 635	7,3	22,2	9 990	16 500	1 100	100	27
	20	3 400	218	393	249	480	0,89	0,88	700	910	2,7	2 326	7,3	22,2	9 990	16 400	1 100	100	27
64	12	3 650	-	-	166	382	0,87	0,84	930	1 200	3	3 328	5,4	25,3	12 900	10 600	984	46	29
	18	3 650	177	363	186	391	0,89	0,87	790	1 030	3	2 900	5,2	25,3	12 900	10 500	914	54	29
	24	3 650	184	345	193	371	0,89	0,88	640	840	3	2 318	5,2	25,3	12 900	10 500	911	54	29
	30	3 650	178	310	199	366	0,89	0,87	440	570	3	1 292	4,9	25,3	12 900	10 300	771	69	29
	36	3 650	173	295	193	348	0,88	0,86	350	450	3	892	4,9	25,3	12 900	10 300	771	69	29

<sup>1)</sup> Standard number of rollers

<sup>2)</sup> Maximum number of rollers on request

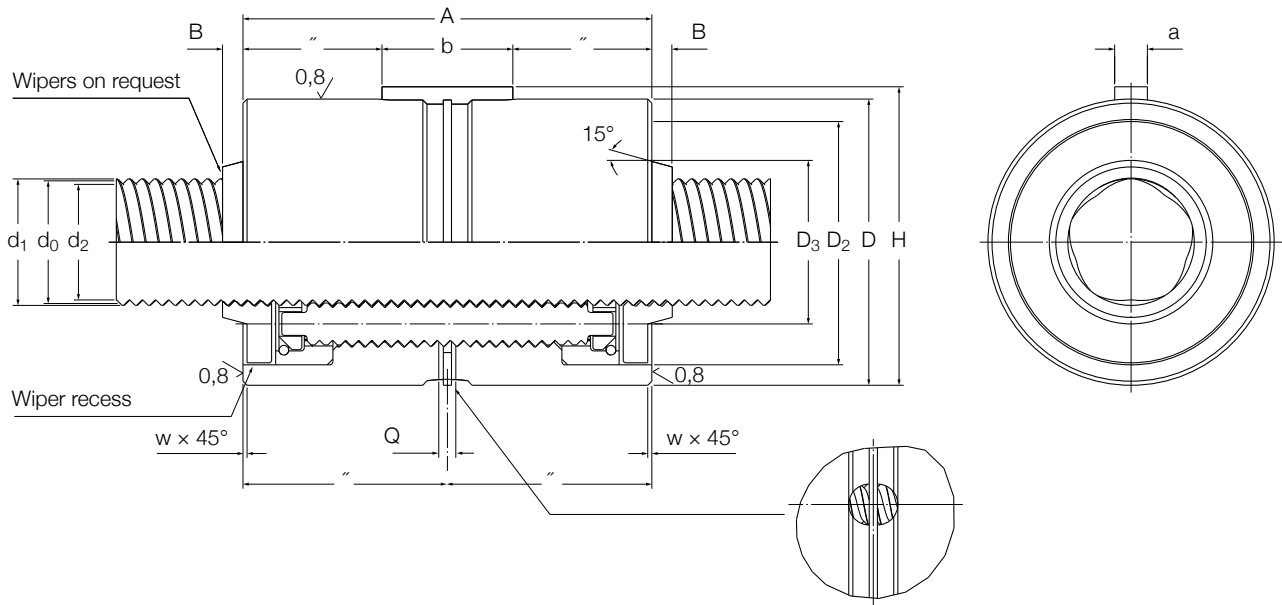

Designation	Dimensions											
	d <sub>1</sub>	d <sub>2</sub>	D	A	w	a	b	H	Q	B	D <sub>2</sub>	D <sub>3</sub>
-	mm											
<b>PRU 60 x 10</b>	60,8	58,9	122	152	1	10	45	125	10,5	9	110	71
<b>PRU 60 x 15</b>	61,2	58,4	122	152	1	10	45	125	10,5	9	110	71
<b>PRU 60 x 20</b>	61,5	57,8	122	152	1	10	45	125	10,5	9	110	71
<b>PRU 64 x 12</b>	64,8	62,9	115	129	1	8	45	118	7	11	106	75
<b>PRU 64 x 18</b>	65,2	62,3	115	129	1	8	45	118	7	11	106	75
<b>PRU 64 x 24</b>	65,5	61,8	115	129	1	8	45	118	7	11	106	75
<b>PRU 64 x 30</b>	65,9	61,2	115	129	1	8	45	118	7	11	106	75
<b>PRU 64 x 36</b>	66,3	60,6	115	129	1	8	45	118	7	11	106	75



## PRK preloaded planetary roller screws with flanged nut

d 8 – 36 mm



Standard PRK

Threaded rollers

Components assembly

### Dimensions and technical characteristics

d <sub>0</sub>	P <sub>h</sub>	L <sub>tp</sub>	C <sub>a</sub> <sup>1)</sup>	C <sub>oa</sub> <sup>1)</sup>	C <sub>a</sub> <sup>2)</sup> max	C <sub>oa</sub> <sup>2)</sup> max	η	η'	R <sub>ng</sub>	R <sub>nr</sub>	T <sub>pr</sub>	F <sub>pr</sub>	m <sub>n</sub>	m <sub>s</sub>	l <sub>s</sub>	l <sub>nn</sub>	l <sub>ns</sub>	Z <sub>n</sub>	Z <sub>s</sub>
mm			kN				-		N/μm		Nm	N	kg	kg/m	kgmm <sup>2</sup> /m	kgmm <sup>2</sup>		cm <sup>3</sup>	cm <sup>3</sup> /m
<b>8</b>	4	400	-	-	4,92	6,72	0,88	0,87	110	150	0,1	236	0,3	0,4	3,2	66,4	0,1	0,9	4
<b>12</b>	5	600	7,76	9,17	8,32	10,2	0,89	0,88	180	240	0,2	570	0,3	0,9	16	106	0,4	1,4	6
<b>15</b>	5	750	14,3	21,8	16,4	26,6	0,89	0,88	290	380	0,3	932	0,5	1,4	39	202	1,2	2,3	7
	8	750	15,1	20,4	16,2	22,7	0,88	0,86	242	315	0,3	954	0,5	1,4	39	202	1,2	2,3	7
<b>18</b>	5	900	-	-	20,8	35,5	0,89	0,87	348	385	0,4	1 078	0,6	2	81	244	5,7	4	8
	8	900	-	-	20,9	30,8	0,89	0,87	202	224	0,4	630	0,6	2	81	244	5,7	4	8
<b>21</b>	5	1 100	27,9	41	31,8	50,1	0,88	0,86	400	520	0,5	1 341	0,7	2,7	150	437	6,5	5	10
	6	1 100	29,1	41,1	33,2	50,2	0,89	0,87	359	467	0,5	1 394	0,7	2,7	150	437	6,5	5	10
	8	1 100	31,4	42,1	35,9	51,4	0,89	0,88	311	404	0,5	1 354	0,7	2,7	150	437	6,5	5	10
	10	1 100	32,6	41,5	35,0	46,1	0,89	0,87	200	260	0,5	557	0,7	2,7	150	437	6,5	5	10
<b>24</b>	6	1 250	23,3	32,6	26,1	38,5	0,88	0,87	370	490	0,6	1 597	0,8	3,6	256	524	6,3	4	11
	12	1 250	26,3	31,2	29,4	36,8	0,88	0,87	150	200	0,6	541	0,8	3,6	256	524	6,3	4	11
<b>25</b>	5	1 300	37,7	60,9	43,1	74,4	0,87	0,85	460	600	0,6	1 577	1,4	3,9	301	1 200	14,3	10	11
	8	1 300	41,9	60,8	47,9	74,3	0,89	0,88	347	385	0,6	1 335	1,4	3,9	301	1 200	14,3	10	11
	10	1 300	43,3	59,2	49,5	72,4	0,89	0,88	290	380	0,6	1 008	1,4	3,9	301	1 200	14,3	10	11
	15	1 300	47,2	59,8	50,6	66,5	0,87	0,85	180	230	0,6	426	1,4	3,9	301	1 200	14,3	10	11
<b>30</b>	5	1 600	50,7	89,2	57,9	109	0,86	0,83	620	810	0,9	1 844	2,1	5,6	624	2 680	36,2	14	14
	6	1 600	52,3	87,7	59,8	107	0,87	0,85	561	729	0,9	1 780	2,1	5,6	624	2 680	36,2	14	14
	8	1 600	56,5	89,1	64,6	109	0,88	0,87	489	544	0,9	1 629	2,1	5,6	624	2 680	36,2	14	14
	10	1 600	58,6	87,2	67	107	0,89	0,88	420	550	0,9	1 472	2,1	5,6	624	2 680	36,2	14	14
	15	1 600	65,4	90,7	70,1	101	0,88	0,87	280	311	0,9	601	2,1	5,6	624	2 680	36,2	14	14
	20	1 600	67,9	88,6	72,9	98,5	0,86	0,83	190	260	1,1	555	2,1	5,6	624	2 680	35,9	14	14
<b>36</b>	6	1 900	49,8	89,7	58,5	114	0,86	0,83	770	1 000	1,2	2 334	2,1	8	1 290	3 170	45,7	13	16
	9	1 900	53,7	87	63,1	111	0,88	0,87	530	689	1,2	1 960	2,1	8	1 290	3 170	45,7	13	16
	12	1 900	58,7	90,6	69	115	0,89	0,88	510	660	1,2	1 820	2,1	8	1 290	3 120	45,7	13	16
	18	1 900	62,9	88,3	70,3	104	0,88	0,87	260	330	1,2	707	2,1	8	1 290	3 120	45,7	13	16
	24	1 900	68,1	92,2	76,1	109	0,86	0,83	240	310	1,5	649	2,1	8	1 290	3 120	45,7	13	16

<sup>1)</sup> Standard number of rollers. Configuration not available for certain sizes

<sup>2)</sup> Maximum number of rollers on request, or standard for certain sizes

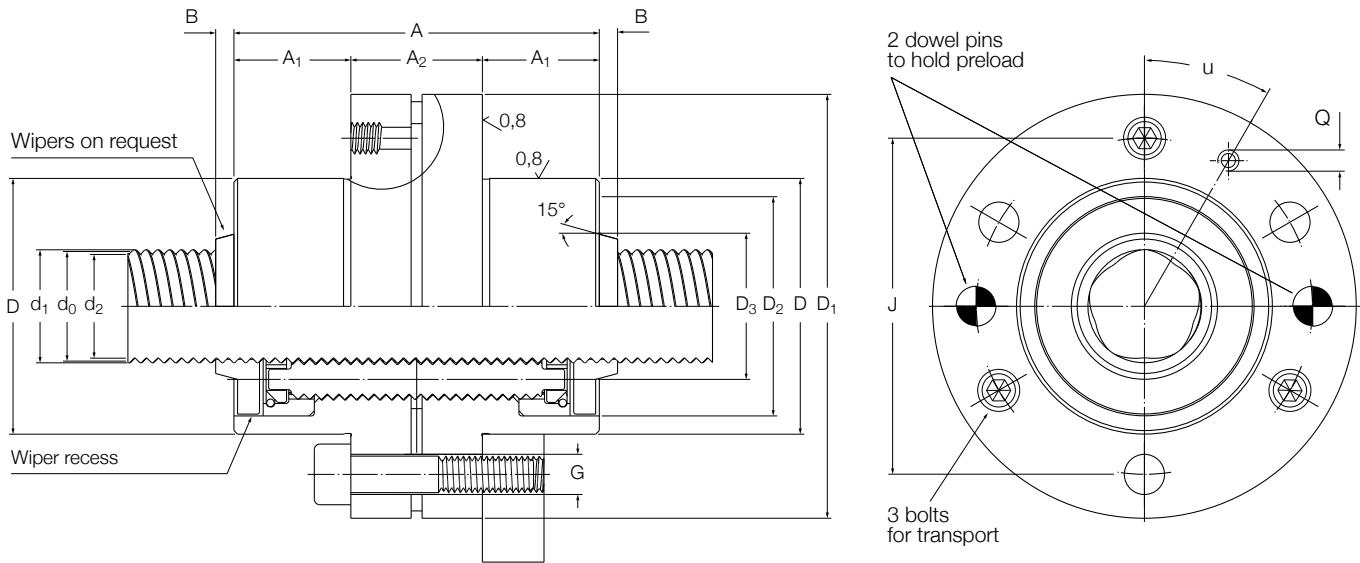

Designation	Dimensions														
	d <sub>1</sub>	d <sub>2</sub>	D	A	A <sub>1</sub>	A <sub>2</sub>	D <sub>1</sub>	J	G	Q	B	D <sub>2</sub>	D <sub>3</sub>	u	
-	mm														
	g6/H7			h12				js12							
PRK 8 x 4	8,4	7,3	25	44	14	16	46	36	6 x M4	M6	3	21	13	30	
PRK 12 x 5	12,4	11,3	30	44	14	16	51	41	6 x M4	M6	3	25	17	30	
PRK 15 x 5	15,4	14,3	35	50	16	18	58	46	6 x M5	M6	3	30	20	30	
PRK 15 x 8	15,6	14	35	50	16	18	58	46	6 x M5	M6	3	30	20	30	
PRK 18 x 5	18,4	17,3	40	58	20	18	63	51	6 x M5	M6	3	35	23	30	
PRK 18 x 8	18,6	17	40	58	20	18	63	51	6 x M5	M6	3	35	23	30	
PRK 21 x 5	21,4	20,3	45	64	23	18	68	56	6 x M5	M6	4	40,5	26	30	
PRK 21 x 6	21,5	20,2	45	64	23	18	68	56	6 x M5	M6	4	40,5	26	30	
PRK 21 x 8	21,6	20	45	64	23	18	68	56	6 x M5	M6	4	40,5	26	30	
PRK 21 x 10	21,8	19,8	45	64	23	18	68	56	6 x M5	M6	4	40,5	26	30	
PRK 24 x 6	24,4	23,3	48	58	20	18	71	59	6 x M5	M6	6	42	31	30	
PRK 24 x 12	24,8	22,8	48	58	20	18	71	59	6 x M5	M6	6	42	31	30	
PRK 25 x 5	25,4	24,3	56	78	29	20	84	70	6 x M6	M6	6	47	32	30	
PRK 25 x 8	25,6	24	56	78	29	20	84	70	6 x M6	M6	6	47	32	30	
PRK 25 x 10	25,8	23,8	56	78	29	20	84	70	6 x M6	M6	6	47	32	30	
PRK 25 x 15	26,2	23,2	56	78	29	20	84	70	6 x M6	M6	6	47	32	30	
PRK 30 x 5	30,4	29,4	64	85	29	27	98	81	6 x M8	M6	7	58	38	30	
PRK 30 x 6	30,5	29,3	64	85	29	27	98	81	6 x M8	M6	7	58	38	30	
PRK 30 x 8	30,6	29	64	85	29	27	98	81	6 x M8	M8	7	58	38	30	
PRK 30 x 10	30,8	28,8	64	85	29	27	98	81	6 x M8	M8	7	58	38	30	
PRK 30 x 15	31,2	28,3	64	85	29	27	98	81	6 x M8	M8	7	58	38	30	
PRK 30 x 20	31,5	27,6	64	85	29	27	98	81	6 x M8	M8	7	58	38	30	
PRK 36 x 6	36,4	35,4	68	80	26,5	27	102	85	6 x M8	M6	8	62	45	30	
PRK 36 x 9	36,6	35,1	68	80	26,5	27	102	85	6 x M8	M6	8	62	45	30	
PRK 36 x 12	36,8	34,8	68	80	26,5	27	102	85	6 x M8	M6	8	62	45	30	
PRK 36 x 18	37,2	34,2	68	80	26,5	27	102	85	6 x M8	M6	8	62	45	30	
PRK 36 x 24	37,5	33,6	68	80	26,5	27	102	85	6 x M8	M6	8	62	45	30	



**PRK preloaded planetary roller screws with flanged nut**

d 39 – 64 mm

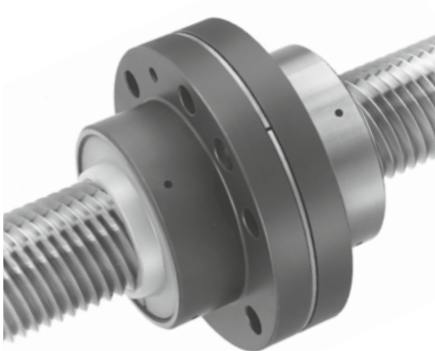

Standard PRK



Threaded rollers



Components assembly

**Dimensions and technical characteristics**

d <sub>0</sub>	P <sub>h</sub>	L <sub>tp</sub>	C <sub>a</sub> <sup>1)</sup>	C <sub>oa</sub> <sup>1)</sup>	C <sub>a</sub> <sup>2)</sup> max	C <sub>oa</sub> <sup>2)</sup> max	η	η'	R <sub>ng</sub>	R <sub>nr</sub>	T <sub>pr</sub>	F <sub>pr</sub>	m <sub>n</sub>	m <sub>s</sub>	l <sub>s</sub>	l <sub>nn</sub>	l <sub>ns</sub>	Z <sub>n</sub>	Z <sub>s</sub>	
mm			kN				-		N/μm		Nm	N	kg	kg/m	kgmm <sup>2</sup> /m	kgmm <sup>2</sup>			cm <sup>3</sup>	cm <sup>3</sup> /m
<b>39</b>	5	2 100	71,2	134	81,4	164	0,83	0,80	750	980	1,3	2 288	4	9,4	1 780	8 360	124	28	18	
	10	2 100	84,1	135	96,1	166	0,88	0,87	500	650	1,3	1 965	4	9,4	1 780	8 360	124	28	18	
	15	2 100	92,4	136	106	167	0,89	0,88	390	510	1,3	1 465	4	9,4	1 780	8 360	124	28	18	
	20	2 100	95,2	130	109	159	0,88	0,87	220	290	1,3	694	4	9,4	1 780	8 360	124	28	18	
	25	2 100	96,3	125	103	138	0,86	0,84	210	280	1,8	697	4	9,4	1 780	8 360	124	28	18	
<b>44</b>	8	2 400	71,9	131	84,4	166	0,86	0,84	761	989	1,6	3 445	3,6	11,9	2 890	8 020	119	23	20	
	12	2 400	79,2	131	93	167	0,89	0,87	610	800	1,6	2 297	3,6	11,9	2 890	8 020	119	23	20	
	18	2 400	86,9	132	102	169	0,89	0,88	430	550	1,6	1 497	3,6	11,9	2 890	8 020	118	23	20	
	24	2 400	92,5	133	103	158	0,88	0,86	290	380	1,6	725	3,6	11,9	2 890	8 020	118	23	20	
	30	2 400	91,4	123	102	146	0,85	0,83	190	250	2,1	724	3,6	11,9	2 890	8 020	118	23	20	
<b>48</b>	5	2 600	109	241	132	321	0,81	0,76	1 080	1 410	1,9	2 698	7,7	14,2	4 090	23 000	371	54	22	
	8	2 600	120	235	138	288	0,86	0,83	889	1 156	1,9	2 583	7,7	14,2	4 090	23 000	371	54	22	
	10	2 600	128	238	146	291	0,87	0,85	760	980	1,9	2 405	7,7	14,2	4 090	23 000	371	54	22	
	15	2 600	142	243	162	297	0,89	0,88	600	780	1,9	2 072	7,7	14,2	4 090	23 000	371	54	22	
	20	2 600	146	231	167	283	0,89	0,88	460	600	1,9	1 423	7,7	14,2	4 090	23 000	371	54	22	
	25	2 600	157	246	180	300	0,88	0,87	320	420	1,9	782	7,7	14,2	4 090	23 000	370	54	22	
<b>56</b>	30	2 600	152	233	174	285	0,87	0,85	344	384	2,5	1 260	7,7	14,2	4 090	23 000	370	54	22	
	12	3 100	117	217	137	276	0,87	0,86	810	1 060	2,4	2 952	6,5	19,3	7 580	21 300	385	46	25	
	24	3 100	133	210	157	267	0,89	0,88	410	530	2,4	1 579	6,5	19,3	7 580	21 300	383	46	25	
<b>60</b>	36	3 100	142	212	159	251	0,86	0,84	290	370	3,2	910	6,5	19,3	7 580	21 300	383	46	25	
	10	3 400	187	390	213	477	0,86	0,83	1 030	1 340	2,7	2 913	12,1	22,2	9 990	52 800	1 100	100	27	
	15	3 400	206	391	235	478	0,88	0,87	830	1 080	2,7	2 635	12,1	22,2	9 990	52 800	1 100	100	27	
<b>64</b>	20	3 400	218	393	249	480	0,89	0,88	700	910	2,7	2 326	12,1	22,2	9 990	52 800	1 100	100	27	
	12	3 650	-	-	166	382	0,87	0,84	930	1 200	3	3 328	11,3	25,3	12 900	50 200	984	46	29	
	18	3 650	177	363	186	391	0,89	0,87	790	1 030	3	2 900	11,3	25,3	12 900	50 200	914	54	29	
	24	3 650	184	345	193	371	0,89	0,88	640	840	3	2 318	11,3	25,3	12 900	50 200	911	54	29	
	30	3 650	178	310	199	366	0,89	0,87	440	570	3	1 292	11,3	25,3	12 900	50 200	771	69	29	
36	3 650	173	295	193	348	0,88	0,86	350	450	3	892	11,3	25,3	12 900	50 200	771	69	29		

<sup>1)</sup> Standard number of rollers. Configuration not available for certain sizes  
<sup>2)</sup> Maximum number of rollers on request, or standard for certain sizes

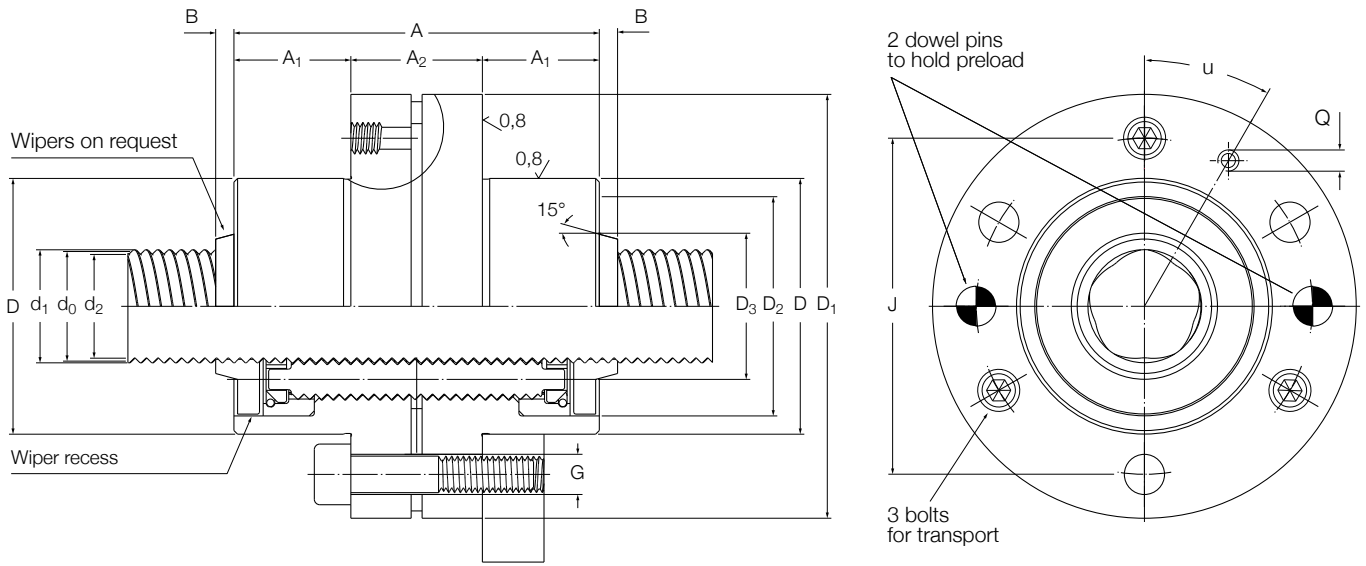

Designation	Dimensions													
	d <sub>1</sub>	d <sub>2</sub>	D	A	A <sub>1</sub>	A <sub>2</sub>	D <sub>1</sub>	J	G	Q	B	D <sub>2</sub>	D <sub>3</sub>	u
-	mm													
PRK 39 x 5	39,4	38,4	82	100	33,5	33	124	102	6 x M10	M6	8	73	50	30
PRK 39 x 10	39,8	37,9	82	100	33,5	33	124	102	6 x M10	M6	8	73	50	30
PRK 39 x 15	40,2	37,3	82	100	33,5	33	124	102	6 x M10	M6	8	73	50	30
PRK 39 x 20	40,5	36,7	82	100	33,5	33	124	102	6 x M10	M6	8	73	50	30
PRK 39 x 25	40,9	36,1	82	100	33,5	33	124	102	6 x M10	M6	8	73	50	30
PRK 44 x 8	44,5	43,2	82	90	28,5	33	124	102	6 x M10	M6	8	74	56	30
PRK 44 x 12	44,8	42,8	82	90	28,5	33	124	102	6 x M10	M6	8	74	56	30
PRK 44 x 18	45,2	42,3	82	90	28,5	33	124	102	6 x M10	M6	8	74	56	30
PRK 44 x 24	45,5	41,7	82	90	28,5	33	124	102	6 x M10	M6	8	74	56	30
PRK 44 x 30	45,9	41,1	82	90	28,5	33	124	102	6 x M10	M6	8	74	56	30
PRK 48 x 5	48,4	47,4	105	127	45	37	150	127	6 x M12	M8 x 1	9	90	60	30
PRK 48 x 8	48,6	47,1	105	127	45	37	150	127	6 x M12	M8 x 1	9	90	60	30
PRK 48 x 10	48,8	46,9	105	127	45	37	150	127	6 x M12	M8 x 1	9	90	60	30
PRK 48 x 15	49,2	46,3	105	127	45	37	150	127	6 x M12	M8 x 1	9	90	60	30
PRK 48 x 20	49,5	45,8	105	127	45	37	150	127	6 x M12	M8 x 1	9	90	60	30
PRK 48 x 25	49,9	45,2	105	127	45	37	150	127	6 x M12	M8 x 1	9	90	60	30
PRK 48 x 30	50,3	44,6	105	127	45	37	150	127	6 x M12	M8 x 1	9	90	60	30
PRK 56 x 12	56,8	54,9	105	112	37,5	37	150	127	6 x M12	M8 x 1	9	93	66	30
PRK 56 x 24	57,5	53,8	105	112	37,5	37	150	127	6 x M12	M8 x 1	9	93	66	30
PRK 56 x 36	58,3	52,5	105	112	37,5	37	150	127	6 x M12	M8 x 1	9	93	66	30
PRK 60 x 10	60,8	58,9	122	152	53,5	45	180	150	6 x M16	M8 x 1	9	110	71	30
PRK 60 x 15	61,2	58,4	122	152	53,5	45	180	150	6 x M16	M8 x 1	9	110	71	30
PRK 60 x 20	61,5	57,8	122	152	53,5	45	180	150	6 x M16	M8 x 1	9	110	71	30
PRK 64 x 12	64,8	62,9	120	129	42	45	180	150	6 x M16	M8 x 1	11	106	75	30
PRK 64 x 18	65,2	62,3	120	129	42	45	180	150	6 x M16	M8 x 1	11	106	75	30
PRK 64 x 24	65,5	61,8	120	129	42	45	180	150	6 x M16	M8 x 1	11	106	75	30
PRK 64 x 30	65,9	61,2	120	129	42	45	180	150	6 x M16	M8 x 1	11	106	75	30
PRK 64 x 36	66,3	60,6	120	129	42	45	180	150	6 x M16	M8 x 1	11	106	75	30

# Ultra Power roller screws HR

## Concept

The Ultra Power roller screws represent the strongest variant of the Ewellix planetary roller screw product line. They are designed for heavy loads and long service life.

The Ewellix Ultra Power assortment of planetary roller screws is optimized to provide a load carrying capacity increase up to 60% over the standard SR planetary roller screw with the same combination of diameter and lead, and, in addition, to reach the maximum possible service life within a compact space.

In order to operate within the principles of rolling fatigue and attain the  $L_{10}$  life performance, the maximum cycle operating load should not exceed 80% of the  $C_a$  value.

The maximum load should be applied on the nut flange, not on the mounting bolts.

Roller screws without backlash or with preloaded split nut are not available in this assortment.

## Application examples

The Ultra Power roller screws offer the power of hydraulic actuators combined with the precision and flexibility of electric control:

- Injection moulding machines for plastic and rubber
- Electro-mechanical presses
- Broaching machines
- Large machine tools
- Off-highway vehicles
- Oil & gas equipment
- Steel industry including casting and rolling
- Friction welding
- Hydro-electric power plants
- Powerful electro-mechanical cylinders
- Heavy lifting equipment

Design features	User benefits
Planetary roller screw concept with maximized load rating	Highest possible load carrying capacity of any type of rolling screw Reliability, resistance to shock loads, robustness in harsh environments
Nominal diameters from 60 mm to 240 mm	Wide standard assortment to fit most heavy duty applications
Long leads up to 50 mm	High linear speed capability with long lead (1 m/s for size 135 x 50)
Shaft lengths up to 8 000 mm for diameters 120 and 135 mm	For additional information about longer shaft lengths, please contact your local Ewellix representative
Maximum $n d_0 = 160\,000$	High speed for increased productivity
High dynamic load carrying capacity up to 3 994 kN for HR assortment	Long service life
High static load carrying capacity up to 23 350 kN for HR assortment	Ability to accommodate heavy shock loads without raceway damage
Ultra Power roller screws is available with axial play lower than 0,07 mm (0,1 mm for screws with lead $\geq 40$ mm)	Unique combination of extreme load carrying capacity and driving accuracy
Standard versions include wipers (WPR in the designation). Screws can be delivered without wipers on request (designation with NOWPR suffix)	Solution contributes to long service life
Standard lead precision is G5, lead precision G3 or G1 on request	Precise driving accuracy
Optional support bearings	Wide variety of spherical roller thrust bearing combinations
Three standard versions are available: <ul style="list-style-type: none"> <li>• HRC: cylindrical nut</li> <li>• HRF: nut with centered flange</li> <li>• HRP: nut with off-centered flange</li> </ul>	Increased design flexibility
Adaptable tooling for non-standard, left hand threads or special designs	Custom solutions on request. Please contact your Ewellix sales office for specific requirements and their feasibility

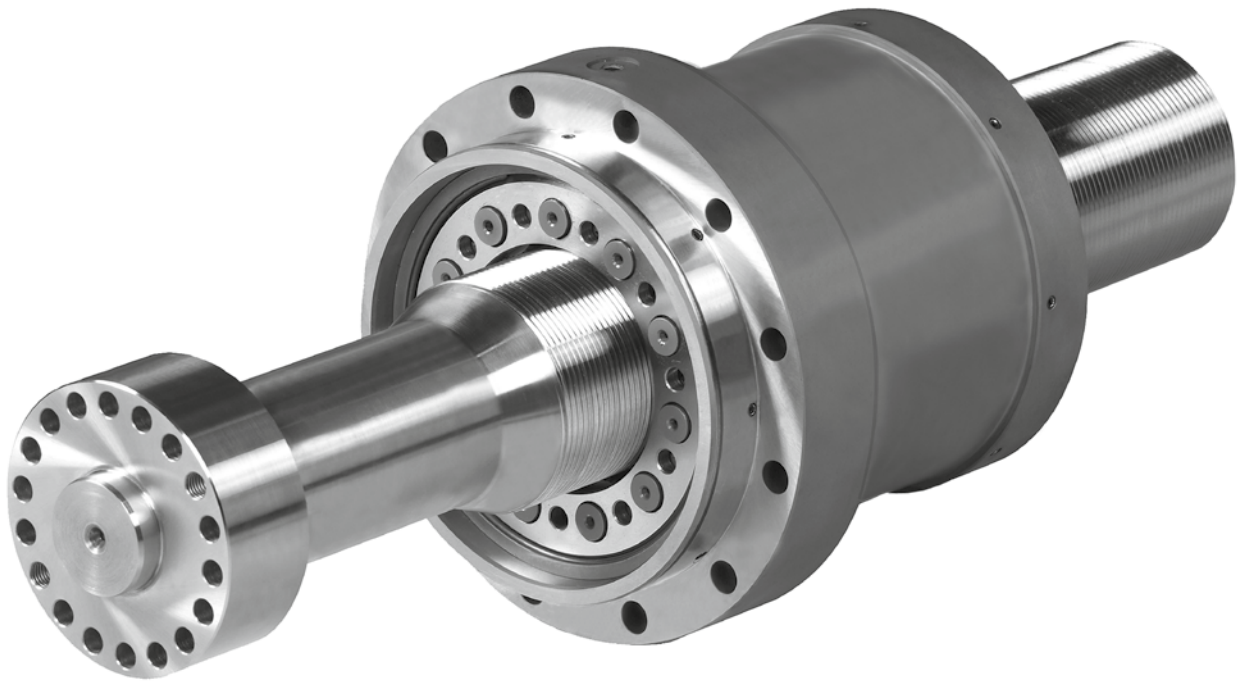

## HRC Ultra Power planetary roller screws with cylindrical nut

d 60 – 120 mm



Standard HRC

Threaded rollers

Components assembly

### Dimensions and technical characteristics

d <sub>0</sub>	P <sub>h</sub>	L <sub>tp</sub>	C <sub>a</sub>	C <sub>0a</sub>	η	η'	S <sub>ap</sub>	m <sub>n</sub>	m <sub>s</sub>	I <sub>s</sub>	I <sub>nn</sub>	I <sub>ns</sub>	Z <sub>n</sub>	Z <sub>s</sub>
			kN		-		mm	kg	kg/m	kgmm <sup>2</sup> /m	kgmm <sup>2</sup>		cm <sup>3</sup>	cm <sup>3</sup> /m
<b>60</b>	15	4 250	494	1 206	0,88	0,87	0,07	9	22,2	9 990	18 700	1 680	90	27
	20	4 250	515	1 181	0,89	0,88	0,07	9	22,2	9 990	18 700	1 680	90	27
	25	4 250	530	1 227	0,89	0,88	0,07	9	22,2	9 990	18 700	1 680	90	27
	30	4 250	528	1 216	0,88	0,87	0,07	9	22,2	9 990	18 700	1 680	90	27
<b>75</b>	15	5 500	836	2 473	0,87	0,85	0,07	16	34,7	24 400	51 700	5 130	170	33
	20	5 500	845	2 455	0,88	0,87	0,07	16	34,7	24 400	51 700	5 130	170	33
	25	5 500	855	2 461	0,89	0,88	0,07	16	34,7	24 400	51 700	5 130	170	33
	30	5 500	852	2 420	0,89	0,88	0,07	16	34,7	24 400	51 700	5 130	170	33
<b>87</b>	15	6 000	1 059	3 527	0,86	0,84	0,07	26	45,8	42 800	111 000	10 600	270	38
	20	6 000	1 061	3 452	0,88	0,86	0,07	26	45,8	42 800	111 000	10 600	270	38
	25	6 000	1 085	3 513	0,89	0,87	0,07	26	45,8	42 800	111 000	10 600	270	38
	30	6 000	1 085	3 465	0,89	0,88	0,07	26	45,8	42 800	111 000	10 600	270	38
<b>99</b>	15	7 500	1 277	4 671	0,85	0,82	0,07	40	60,4	74 000	220 000	20 400	400	44
	20	7 500	1 311	4 741	0,87	0,85	0,07	40	60,4	74 000	220 000	20 400	400	44
	25	7 500	1 328	4 749	0,88	0,87	0,07	40	60,4	74 000	220 000	20 400	400	44
	30	7 500	1 330	4 694	0,89	0,87	0,07	40	60,4	74 000	220 000	20 400	400	44
	35	7 500	1 329	4 639	0,89	0,88	0,07	40	60,4	74 000	220 000	20 400	400	44
<b>112,5</b>	15	7 500	1 396	5 288	0,84	0,80	0,07	58	76,8	120 000	423 000	37 100	550	50
	20	7 500	1 421	5 297	0,86	0,84	0,07	58	76,8	120 000	423 000	37 100	550	50
	25	7 500	1 446	5 341	0,88	0,86	0,07	58	76,8	120 000	423 000	37 100	550	50
	30	7 500	1 455	5 315	0,88	0,87	0,07	58	76,8	120 000	423 000	37 100	550	50
	35	7 500	1 461	5 289	0,89	0,88	0,07	58	76,8	120 000	423 000	37 100	550	50
<b>120</b>	15	8 000	1 547	6 179	0,83	0,79	0,07	64	88,8	160 000	516 000	47 200	700	53
	20	8 000	1 587	6 263	0,86	0,83	0,07	64	88,8	160 000	516 000	47 200	700	53
	25	8 000	1 585	6 123	0,87	0,85	0,07	64	88,8	160 000	516 000	47 200	700	53
	30	8 000	1 614	6 207	0,88	0,87	0,07	64	88,8	160 000	516 000	47 200	700	53
	35	8 000	1 640	6 291	0,89	0,87	0,07	64	88,8	160 000	516 000	47 200	700	53
	40	8 000	1 651	6 301	0,89	0,88	0,1	64	88,8	160 000	516 000	47 200	700	53

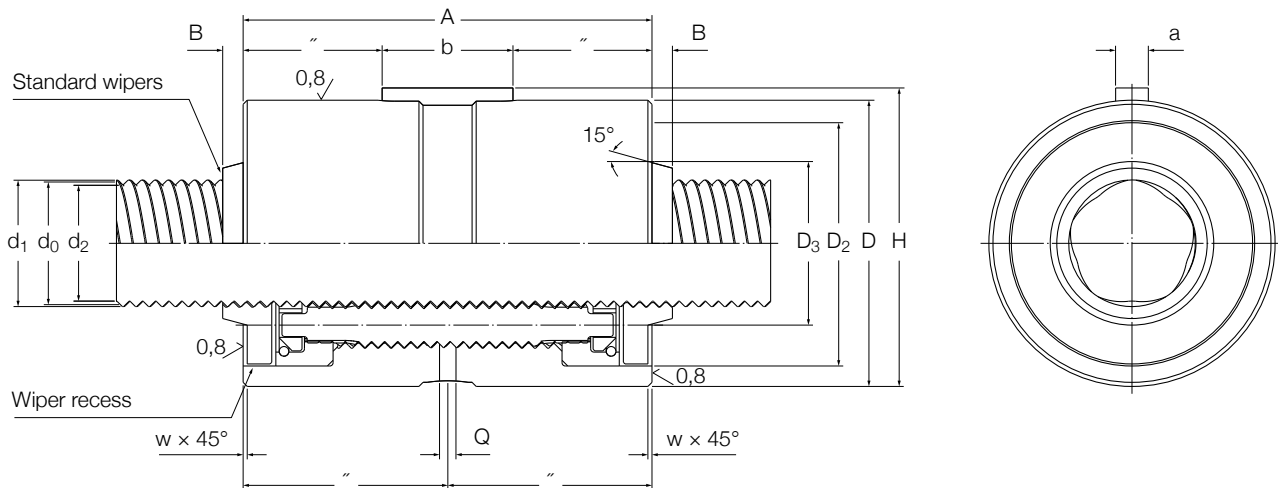

Designation	Dimensions											
	d <sub>1</sub>	d <sub>2</sub>	D g6/H7	A	w	a h9	b	H	Q	B	D <sub>2</sub>	D <sub>3</sub>
-	mm											
HRC 60 x 15	61,1	58,5	122	171	1	10	56	125	11	9	110	71
HRC 60 x 20	61,5	58,0	122	171	1	10	56	125	11	9	110	71
HRC 60 x 25	61,9	57,5	122	171	1	10	56	125	11	9	110	71
HRC 60 x 30	62,3	57,0	122	171	1	10	56	125	11	9	110	71
HRC 75 x 15	76,1	73,5	150	213	1	10	63	153	11	10	136	87
HRC 75 x 20	76,5	73,0	150	213	1	10	63	153	11	10	136	87
HRC 75 x 25	76,9	72,5	150	213	1	10	63	153	11	10	136	87
HRC 75 x 30	77,3	72,0	150	213	1	10	63	153	11	10	136	87
HRC 87 x 15	88,1	85,5	175	245	1,5	12	100	178	12	12	158	103
HRC 87 x 20	88,5	85,0	175	245	1,5	12	100	178	12	12	158	103
HRC 87 x 25	88,9	84,5	175	245	1,5	12	100	178	12	12	158	103
HRC 87 x 30	89,3	84,0	175	245	1,5	12	100	178	12	12	158	103
HRC 99 x 15	100,1	97,5	200	280	1,5	16	100	204	15	12	180	112
HRC 99 x 20	100,5	97,0	200	280	1,5	16	100	204	15	12	180	112
HRC 99 x 25	100,9	96,5	200	280	1,5	16	100	204	15	12	180	112
HRC 99 x 30	101,3	96,0	200	280	1,5	16	100	204	15	12	180	112
HRC 99 x 35	101,6	95,5	200	280	1,5	16	100	204	15	12	180	112
HRC 112.5 x 15	113,6	111,0	230	300	1,5	16	100	234	15	12	210	140
HRC 112.5 x 20	114,0	110,5	230	300	1,5	16	100	234	15	12	210	140
HRC 112.5 x 25	114,4	110,0	230	300	1,5	16	100	234	15	12	210	140
HRC 112.5 x 30	114,8	109,5	230	300	1,5	16	100	234	15	12	210	140
HRC 112.5 x 35	115,1	109,0	230	300	1,5	16	100	234	15	12	210	140
HRC 120 x 15	121,1	118,5	240	330	1,5	16	100	244	15	12	220	180
HRC 120 x 20	121,5	118,0	240	330	1,5	16	100	244	15	12	220	180
HRC 120 x 25	121,9	117,5	240	330	1,5	16	100	244	15	12	220	180
HRC 120 x 30	122,3	117,0	240	330	1,5	16	100	244	15	12	220	180
HRC 120 x 35	122,6	116,5	240	330	1,5	16	100	244	15	12	220	180
HRC 120 x 40	123,0	116,0	240	330	1,5	16	100	244	15	12	220	180

## HRC Ultra Power planetary roller screws with cylindrical nut

d 135 – 240 mm



Standard HRC

Threaded rollers

Components assembly

### Dimensions and technical characteristics

$d_0$	$P_h$	$L_{tp}$	$C_a$	$C_{0a}$	$\eta$	$\eta'$	$S_{ap}$	$m_n$	$m_s$	$I_s$	$I_{nn}$	$I_{ns}$	$Z_n$	$Z_s$
			kN		-		mm	kg	kg/m	kgmm <sup>2</sup> /m	kgmm <sup>2</sup>		cm <sup>3</sup>	cm <sup>3</sup> /m
<b>135</b>	15	8 000	1 843	8 037	0,82	0,77	0,07	108	113	261 000	1,18 x 106	94 200	980	60
	20	8 000	1 858	7 922	0,85	0,82	0,07	108	113	261 000	1,18 x 106	94 200	980	60
	25	8 000	1 903	8 059	0,86	0,84	0,07	108	113	261 000	1,18 x 106	94 200	980	60
	30	8 000	1 904	7 943	0,88	0,86	0,07	108	113	261 000	1,18 x 106	94 200	980	60
	35	8 000	1 921	7 953	0,88	0,87	0,07	108	113	261 000	1,18 x 106	94 200	980	60
	40	8 000	1 909	7 796	0,89	0,87	0,1	108	113	261 000	1,18 x 106	94 200	980	60
50	8 000	1 944	7 901	0,89	0,88	0,1	108	113	261 000	1,18 x 106	94 200	980	60	
<b>150</b>	15	7 200	2 200	10 446	0,8	0,75	0,07	163	139	390 000	2,35 x 106	160 000	1 350	66
	20	7 200	2 240	10 459	0,84	0,80	0,07	163	139	390 000	2,35 x 106	160 000	1 350	66
	25	7 200	2 137	9 553	0,86	0,83	0,07	163	139	390 000	2,35 x 106	160 000	1 350	66
	30	7 200	2 167	9 611	0,87	0,85	0,07	163	139	390 000	2,35 x 106	160 000	1 350	66
	35	7 200	2 167	9 483	0,88	0,86	0,07	163	139	390 000	2,35 x 106	160 000	1 350	66
	40	7 200	2 176	9 449	0,88	0,87	0,1	163	139	390 000	2,35 x 106	160 000	1 350	66
50	7 200	2 189	9 379	0,89	0,88	0,1	163	139	390 000	2,35 x 106	160 000	1 350	66	
<b>180</b>	15	5 000	3 073	17 366	0,78	0,71	0,07	310	200	809 000	6,54 x 106	437 000	2 500	79
	20	5 000	3 123	17 319	0,82	0,77	0,07	310	200	809 000	6,54 x 106	437 000	2 500	79
	25	5 000	3 002	16 004	0,84	0,81	0,07	310	200	809 000	6,54 x 106	437 000	2 500	79
	30	5 000	3 009	15 790	0,86	0,83	0,07	310	200	809 000	6,54 x 106	437 000	2 500	79
	35	5 000	3 023	15 690	0,87	0,85	0,07	310	200	809 000	6,54 x 106	437 000	2 500	79
	40	5 000	3 075	15 931	0,88	0,86	0,1	310	200	809 000	6,54 x 106	437 000	2 500	79
50	5 000	3 128	16 073	0,89	0,87	0,1	310	200	809 000	6,54 x 106	437 000	2 500	79	
<b>210</b>	20	3 700	3 371	19 164	0,80	0,74	0,07	416	270	1,49 x 106	11,2 x 106	854 000	3 150	92
	25	3 700	3 435	19 324	0,82	0,79	0,07	416	270	1,49 x 106	11,2 x 106	854 000	3 150	92
	30	3 700	3 249	17 472	0,84	0,81	0,07	416	270	1,49 x 106	11,2 x 106	854 000	3 150	92
	35	3 700	3 265	17 359	0,86	0,83	0,07	416	270	1,49 x 106	11,2 x 106	854 000	3 150	92
	40	3 700	3 322	17 635	0,87	0,85	0,1	416	270	1,49 x 106	11,2 x 106	854 000	3 150	92
	50	3 700	3 381	17 798	0,88	0,86	0,1	416	270	1,49 x 106	11,2 x 106	854 000	3 150	92
<b>240</b>	25	2 800	3 919	23 387	0,81	0,76	0,07	533	353	2,54 x 106	17 x 106	1,19 x 106	5 000	106
	30	2 800	3 931	23 089	0,83	0,79	0,07	533	353	2,54 x 106	17 x 106	1,19 x 106	5 000	106
	35	2 800	3 994	23 350	0,84	0,82	0,07	533	353	2,54 x 106	17 x 106	1,19 x 106	5 000	106
	40	2 800	3 808	21 497	0,86	0,83	0,1	533	353	2,54 x 106	17 x 106	1,19 x 106	5 000	106
	50	2 800	3 860	21 536	0,87	0,85	0,1	533	353	2,54 x 106	17 x 106	1,19 x 106	5 000	106

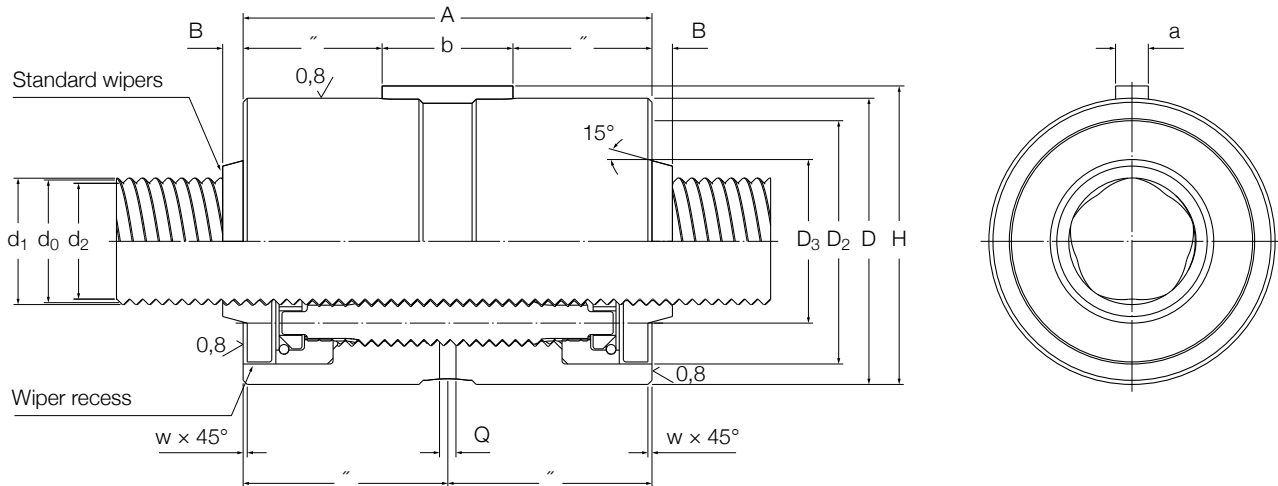

Designation	Dimensions											
	d <sub>1</sub>	d <sub>2</sub>	D	A	w	a	b	H	Q	B	D <sub>2</sub>	D <sub>3</sub>
-	mm											
			g6/H7			h9						
HRC 135 x 15	136,1	133,5	280	370	2	28	120	286	15	11,5	250	180
HRC 135 x 20	136,5	133,0	280	370	2	28	120	286	15	11,5	250	180
HRC 135 x 25	136,9	132,5	280	370	2	28	120	286	15	11,5	250	180
HRC 135 x 30	137,3	132,0	280	370	2	28	120	286	15	11,5	250	180
HRC 135 x 35	137,6	131,5	280	370	2	28	120	286	15	11,5	250	180
HRC 135 x 40	138,0	131,0	280	370	2	28	120	286	15	11,5	250	180
HRC 135 x 50	138,8	130,0	280	370	2	28	120	286	15	11,5	250	180
HRC 150 x 15	151,1	148,5	320	412	3	32	160	327	15	12,5	280	230
HRC 150 x 20	151,5	148,0	320	412	3	32	160	327	15	12,5	280	230
HRC 150 x 25	151,9	147,5	320	412	3	32	160	327	15	12,5	280	230
HRC 150 x 30	152,3	147,0	320	412	3	32	160	327	15	12,5	280	230
HRC 150 x 35	152,6	146,5	320	412	3	32	160	327	15	12,5	280	230
HRC 150 x 40	153,0	146,0	320	412	3	32	160	327	15	12,5	280	230
HRC 150 x 50	153,8	145,0	320	412	3	32	160	327	15	12,5	280	230
HRC 180 x 15	181,1	178,5	390	528	3	32	160	397	20	15	340	250
HRC 180 x 20	181,5	178,0	390	528	3	32	160	397	20	15	340	250
HRC 180 x 25	181,9	177,5	390	528	3	32	160	397	20	15	340	250
HRC 180 x 30	182,3	177,0	390	528	3	32	160	397	20	15	340	250
HRC 180 x 35	182,6	176,5	390	528	3	32	160	397	20	15	340	250
HRC 180 x 40	183,0	176,0	390	528	3	32	160	397	20	15	340	250
HRC 180 x 50	183,8	175,0	390	528	3	32	160	397	20	15	340	250
HRC 210 x 20	211,5	208,0	440	570	3	40	200	450	20	15	398	250
HRC 210 x 25	211,9	207,5	440	570	3	40	200	450	20	15	398	250
HRC 210 x 30	212,3	207,0	440	570	3	40	200	450	20	15	398	250
HRC 210 x 35	212,6	206,5	440	570	3	40	200	450	20	15	398	250
HRC 210 x 40	213,0	206,0	440	570	3	40	200	450	20	15	398	250
HRC 210 x 50	213,8	205,0	440	570	3	40	200	450	20	15	398	250
HRC 240 x 25	241,9	237,5	490	600	3	50	200	501	20	15	448	290
HRC 240 x 30	242,3	237,0	490	600	3	50	200	501	20	15	448	290
HRC 240 x 35	242,6	236,5	490	600	3	50	200	501	20	15	448	290
HRC 240 x 40	243,0	236,0	490	600	3	50	200	501	20	15	448	290
HRC 240 x 50	243,8	235,0	490	600	3	50	200	501	20	15	448	290

## HRF/HRP Ultra Power planetary roller screws with flanged nut

d 60 – 120 mm

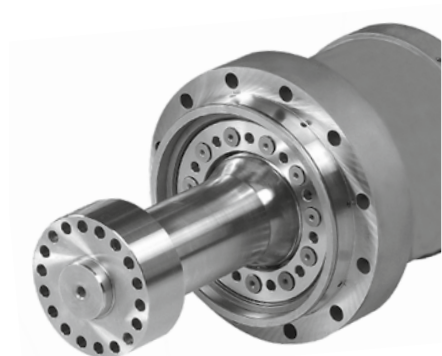

HRP



Threaded rollers



Components assembly

### Dimensions and technical characteristics

$d_0$	$P_h$	$L_{tp}$	$C_a$	$C_{0a}$	$\eta$	$\eta'$	$S_{ap}$	$m_n$	$m_s$	$I_s$	$I_{nn}$	$I_{ns}$	$Z_n$	$Z_s$
			kN		-		mm	kg	kg/m	kgmm <sup>2</sup> /m	kgmm <sup>2</sup>		cm <sup>3</sup>	cm <sup>3</sup> /m
<b>60</b>	15	4 250	495	1 206	0,88	0,87	0,07	13	22,2	9 990	29 700	1 680	90	27
	20	4 250	515	1 181	0,89	0,88	0,07	13	22,2	9 990	29 700	1 680	90	27
	25	4 250	530	1 227	0,89	0,88	0,07	13	22,2	9 990	29 700	1 680	90	27
	30	4 250	528	1 216	0,88	0,87	0,07	13	22,2	9 990	29 700	1 680	90	27
<b>75</b>	15	5 500	836	2 473	0,87	0,85	0,07	20	34,7	24 400	73 400	5 130	170	33
	20	5 500	845	2 455	0,88	0,87	0,07	20	34,7	24 400	73 400	5 130	170	33
	25	5 500	855	2 461	0,89	0,88	0,07	20	34,7	24 400	73 400	5 130	170	33
	30	5 500	852	2 420	0,89	0,88	0,07	20	34,7	24 400	73 400	5 130	170	33
<b>87</b>	15	6 000	1 059	3 527	0,86	0,84	0,07	31	45,8	42 800	149 000	10 600	270	38
	20	6 000	1 061	3 452	0,88	0,86	0,07	31	45,8	42 800	149 000	10 600	270	38
	25	6 000	1 085	3 513	0,89	0,87	0,07	31	45,8	42 800	149 000	10 600	270	38
	30	6 000	1 085	3 465	0,89	0,88	0,07	31	45,8	42 800	149 000	10 600	270	38
<b>99</b>	15	7 500	1 277	4 671	0,85	0,82	0,07	46	60,4	74 000	288 000	20 400	400	44
	20	7 500	1 311	4 741	0,87	0,85	0,07	46	60,4	74 000	288 000	20 400	400	44
	25	7 500	1 328	4 749	0,88	0,87	0,07	46	60,4	74 000	288 000	20 400	400	44
	30	7 500	1 330	4 694	0,89	0,87	0,07	46	60,4	74 000	288 000	20 400	400	44
	35	7 500	1 329	4 639	0,89	0,88	0,07	46	60,4	74 000	288 000	20 400	400	44
<b>112,5</b>	15	7 500	1 396	5 288	0,84	0,80	0,07	66	76,8	120 000	552 000	37 100	550	50
	20	7 500	1 421	5 297	0,86	0,84	0,07	66	76,8	120 000	552 000	37 100	550	50
	25	7 500	1 446	5 341	0,88	0,86	0,07	66	76,8	120 000	552 000	37 100	550	50
	30	7 500	1 455	5 315	0,88	0,87	0,07	66	76,8	120 000	552 000	37 100	550	50
	35	7 500	1 461	5 289	0,89	0,88	0,07	66	76,8	120 000	552 000	37 100	550	50
<b>120</b>	15	8 000	1 547	6 179	0,83	0,79	0,07	73	88,8	160 000	676 000	47 200	700	53
	20	8 000	1 587	6 263	0,86	0,83	0,07	73	88,8	160 000	676 000	47 200	700	53
	25	8 000	1 585	6 123	0,87	0,85	0,07	73	88,8	160 000	676 000	47 200	700	53
	30	8 000	1 614	6 207	0,88	0,87	0,07	73	88,8	160 000	676 000	47 200	700	53
	35	8 000	1 640	6 291	0,89	0,87	0,07	73	88,8	160 000	676 000	47 200	700	53
	40	8 000	1 651	6 301	0,89	0,88	0,1	73	88,8	160 000	676 000	47 200	700	53

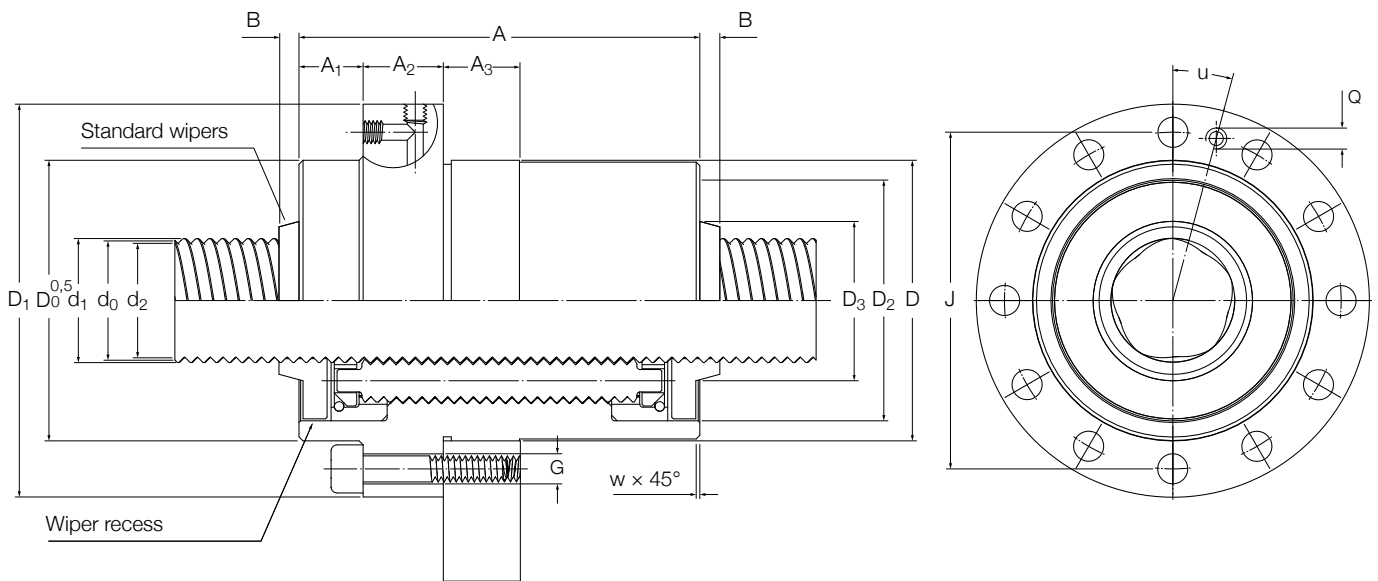

Designation	Dimensions																
	d <sub>1</sub>	d <sub>2</sub>	D	A	A <sub>1</sub>	A <sub>1</sub>	A <sub>3</sub>	A <sub>2</sub>	D <sub>1</sub>	J	G	W	Q	B	D <sub>2</sub>	D <sub>3</sub>	u
-	mm																
			g6/H7	h12	HRF	HRP				js12							
<b>HRF/HRP 60 x 15</b>	61,1	58,5	122	171	70,5	25	40	30	166	146	8 x M12	1	M8 x 1	9	110	71	22,5
<b>HRF/HRP 60 x 20</b>	61,5	58,0	122	171	70,5	25	40	30	166	146	8 x M12	1	M8 x 1	9	110	71	22,5
<b>HRF/HRP 60 x 25</b>	61,9	57,5	122	171	70,5	25	40	30	166	146	8 x M12	1	M8 x 1	9	110	71	22,5
<b>HRF/HRP 60 x 30</b>	62,3	57,0	122	171	70,5	25	40	30	166	146	8 x M12	1	M8 x 1	9	110	71	22,5
<b>HRF/HRP 75 x 15</b>	76,1	73,5	150	213	89	30	40	35	195	174	12 x M12	1	M8 x 1	10	136	87	15
<b>HRF/HRP 75 x 20</b>	76,5	73,0	150	213	89	30	40	35	195	174	12 x M12	1	M8 x 1	10	136	87	15
<b>HRF/HRP 75 x 25</b>	76,9	72,5	150	213	89	30	40	35	195	174	12 x M12	1	M8 x 1	10	136	87	15
<b>HRF/HRP 75 x 30</b>	77,3	72,0	150	213	89	30	40	35	195	174	12 x M12	1	M8 x 1	10	136	87	15
<b>HRF/HRP 87 x 15</b>	88,1	85,5	175	245	102,5	35	40	40	220	200	12 x M12	1,5	M8 x 1	12	158	103	15
<b>HRF/HRP 87 x 20</b>	88,5	85,0	175	245	102,5	35	40	40	220	200	12 x M12	1,5	M8 x 1	12	158	103	15
<b>HRF/HRP 87 x 25</b>	88,9	84,5	175	245	102,5	35	40	40	220	200	12 x M12	1,5	M8 x 1	12	158	103	15
<b>HRF/HRP 87 x 30</b>	89,3	84,0	175	245	102,5	35	40	40	220	200	12 x M12	1,5	M8 x 1	12	158	103	15
<b>HRF/HRP 99 x 15</b>	100,1	97,5	200	280	115	40	40	50	245	224	12 x M12	1,5	M8 x 1	12	180	112	15
<b>HRF/HRP 99 x 20</b>	100,5	97,0	200	280	115	40	40	50	245	224	12 x M12	1,5	M8 x 1	12	180	112	15
<b>HRF/HRP 99 x 25</b>	100,9	96,5	200	280	115	40	40	50	245	224	12 x M12	1,5	M8 x 1	12	180	112	15
<b>HRF/HRP 99 x 30</b>	101,3	96,0	200	280	115	40	40	50	245	224	12 x M12	1,5	M8 x 1	12	180	112	15
<b>HRF/HRP 99 x 35</b>	101,6	95,5	200	280	115	40	40	50	245	224	12 x M12	1,5	M8 x 1	12	180	112	15
<b>HRF/HRP 112,5 x 15</b>	113,6	111,0	230	300	125	50	40	50	286	260	12 x M16	1,5	M12 x 1,75	12	210	140	15
<b>HRF/HRP 112,5 x 20</b>	114,0	110,5	230	300	125	50	40	50	286	260	12 x M16	1,5	M12 x 1,75	12	210	140	15
<b>HRF/HRP 112,5 x 25</b>	114,4	110,0	230	300	125	50	40	50	286	260	12 x M16	1,5	M12 x 1,75	12	210	140	15
<b>HRF/HRP 112,5 x 30</b>	114,8	109,5	230	300	125	50	40	50	286	260	12 x M16	1,5	M12 x 1,75	12	210	140	15
<b>HRF/HRP 112,5 x 35</b>	115,1	109,0	230	300	125	50	40	50	286	260	12 x M16	1,5	M12 x 1,75	12	210	140	15
<b>HRF/HRP 120 x 15</b>	121,1	118,5	240	330	137,5	50	60	55	296	270	12 x M16	1,5	M12 x 1,75	12	220	180	15
<b>HRF/HRP 120 x 20</b>	121,5	118,0	240	330	137,5	50	60	55	296	270	12 x M16	1,5	M12 x 1,75	12	220	180	15
<b>HRF/HRP 120 x 25</b>	121,9	117,5	240	330	137,5	50	60	55	296	270	12 x M16	1,5	M12 x 1,75	12	220	180	15
<b>HRF/HRP 120 x 30</b>	122,3	117,0	240	330	137,5	50	60	55	296	270	12 x M16	1,5	M12 x 1,75	12	220	180	15
<b>HRF/HRP 120 x 35</b>	122,6	116,5	240	330	137,5	50	60	55	296	270	12 x M16	1,5	M12 x 1,75	12	220	180	15
<b>HRF/HRP 120 x 40</b>	123,0	116,0	240	330	137,5	50	60	55	296	270	12 x M16	1,5	M12 x 1,75	12	220	180	15

## HRF/HRP Ultra Power planetary roller screws with flanged nut

d 135 – 240 mm



HRP



Threaded rollers



Components assembly

### Dimensions and technical characteristics

$d_0$	$F_h$	$L_{tp}$	$C_a$	$C_{0a}$	$\eta$	$\eta'$	$S_{ap}$	$m_n$	$m_s$	$I_s$	$I_{nn}$	$I_{ns}$	$Z_n$	$Z_s$
			kN		-		mm	kg	kg/m	kgmm <sup>2</sup> /m	kgmm <sup>2</sup>		cm <sup>3</sup>	cm <sup>3</sup> /m
<b>135</b>	15	8 000	1 843	8 037	0,82	0,77	0,07	122	113	261 000	1,5 x 106	94 200	980	60
	20	8 000	1 858	7 922	0,85	0,82	0,07	122	113	261 000	1,5 x 106	94 200	980	60
	25	8 000	1 903	8 059	0,86	0,84	0,07	122	113	261 000	1,5 x 106	94 200	980	60
	30	8 000	1 904	7 943	0,88	0,86	0,07	122	113	261 000	1,5 x 106	94 200	980	60
	35	8 000	1 921	7 953	0,88	0,87	0,07	122	113	261 000	1,5 x 106	94 200	980	60
	40	8 000	1 909	7 796	0,89	0,87	0,1	122	113	261 000	1,5 x 106	94 200	980	60
50	8 000	1 944	7 901	0,89	0,88	0,1	122	113	261 000	1,5 x 106	94 200	980	60	
<b>150</b>	15	7 200	2 200	10 446	0,80	0,75	0,07	180	139	390 000	2,9 x 106	160 000	1 350	66
	20	7 200	2 240	10 459	0,84	0,80	0,07	180	139	390 000	2,9 x 106	160 000	1 350	66
	25	7 200	2 137	9 553	0,86	0,83	0,07	180	139	390 000	2,9 x 106	160 000	1 350	66
	30	7 200	2 167	9 611	0,87	0,85	0,07	180	139	390 000	2,9 x 106	160 000	1 350	66
	35	7 200	2 167	9 483	0,88	0,86	0,07	180	139	390 000	2,9 x 106	160 000	1 350	66
	40	7 200	2 176	9 449	0,88	0,87	0,1	180	139	390 000	2,9 x 106	160 000	1 350	66
50	7 200	2 189	9 379	0,89	0,88	0,1	180	139	390 000	2,9 x 106	160 000	1 350	66	
<b>180</b>	15	5 000	3 073	17 366	0,78	0,71	0,07	344	200	809 000	8,2 x 106	437 000	2 500	79
	20	5 000	3 123	17 319	0,82	0,77	0,07	344	200	809 000	8,2 x 106	437 000	2 500	79
	25	5 000	3 002	16 004	0,84	0,81	0,07	344	200	809 000	8,2 x 106	437 000	2 500	79
	30	5 000	3 009	15 790	0,86	0,83	0,07	344	200	809 000	8,2 x 106	437 000	2 500	79
	35	5 000	3 023	15 690	0,87	0,85	0,07	344	200	809 000	8,2 x 106	437 000	2 500	79
	40	5 000	3 075	15 931	0,88	0,86	0,1	344	200	809 000	8,2 x 106	437 000	2 500	79
50	5 000	3 128	16 073	0,89	0,87	0,1	344	200	809 000	8,2 x 106	437 000	2 500	79	
<b>210</b>	20	3 700	3 371	19 164	0,80	0,74	0,07	465	270	1,49 x 106	14,1 x 106	854 000	3 150	92
	25	3 700	3 435	19 324	0,82	0,79	0,07	465	270	1,49 x 106	14,1 x 106	854 000	3 150	92
	30	3 700	3 249	17 472	0,84	0,81	0,07	465	270	1,49 x 106	14,1 x 106	854 000	3 150	92
	35	3 700	3 265	17 359	0,86	0,83	0,07	465	270	1,49 x 106	14,1 x 106	854 000	3 150	92
	40	3 700	3 322	17 635	0,87	0,85	0,1	465	270	1,49 x 106	14,1 x 106	854 000	3 150	92
50	3 700	3 381	17 798	0,88	0,86	0,1	465	270	1,49 x 106	14,1 x 106	854 000	3 150	92	
<b>240</b>	25	2 800	3 919	23 387	0,81	0,76	0,07	594	353	2,54 x 106	21,4 x 106	1,19 x 106	5 000	106
	30	2 800	3 931	23 089	0,83	0,79	0,07	594	353	2,54 x 106	21,4 x 106	1,19 x 106	5 000	106
	35	2 800	3 994	23 350	0,84	0,82	0,07	594	353	2,54 x 106	21,4 x 106	1,19 x 106	5 000	106
	40	2 800	3 808	21 497	0,86	0,83	0,1	594	353	2,54 x 106	21,4 x 106	1,19 x 106	5 000	106
	50	2 800	3 860	21 536	0,87	0,85	0,1	594	353	2,54 x 106	21,4 x 106	1,19 x 106	5 000	106

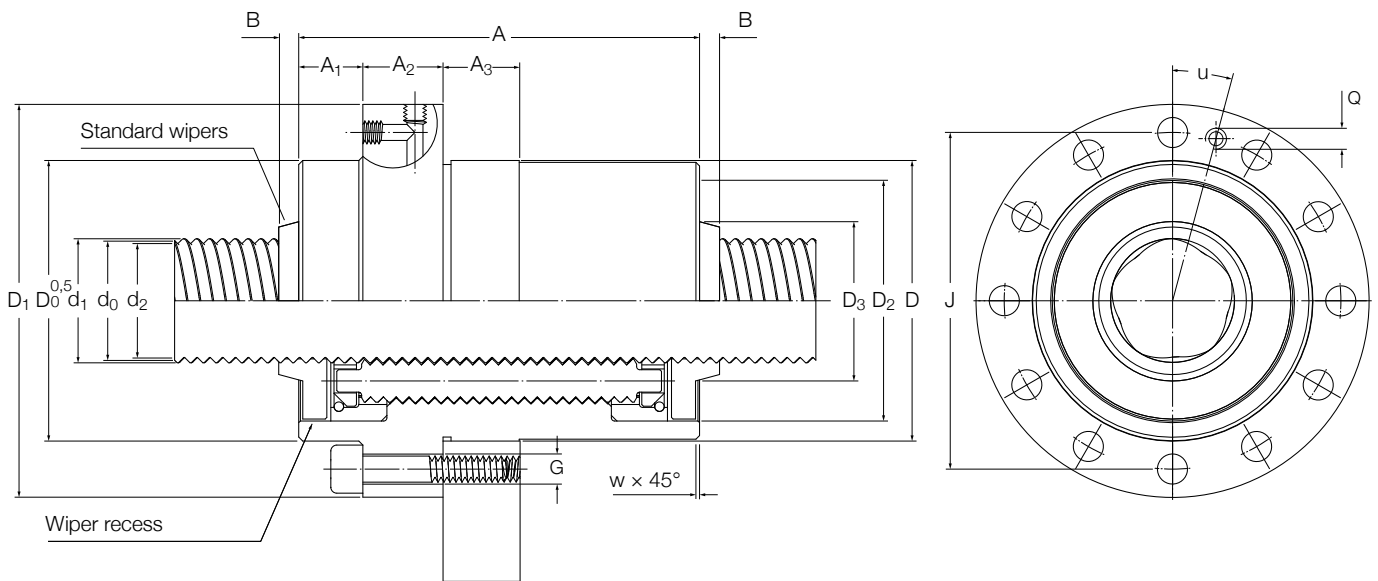

**Designation**

**Dimensions**

	d <sub>1</sub>	d <sub>2</sub>	D	A	A <sub>1</sub>	A <sub>1</sub>	A <sub>3</sub>	A <sub>2</sub>	D <sub>1</sub>	J	G	W	Q	B	D <sub>2</sub>	D <sub>3</sub>	u
-	mm		g6/H7	h12	HRF	HRP				js12							
<b>HRF/HRP 135 x 15</b>	136,1	133,5	280	370	155	60	80	60	345	315	12 x M18	2	M12 x 1,75	11,5	250	180	15
<b>HRF/HRP 135 x 20</b>	136,5	133,0	280	370	155	60	80	60	345	315	12 x M18	2	M12 x 1,75	11,5	250	180	15
<b>HRF/HRP 135 x 25</b>	136,9	132,5	280	370	155	60	80	60	345	315	12 x M18	2	M12 x 1,75	11,5	250	180	15
<b>HRF/HRP 135 x 30</b>	137,3	132,0	280	370	155	60	80	60	345	315	12 x M18	2	M12 x 1,75	11,5	250	180	15
<b>HRF/HRP 135 x 35</b>	137,6	131,5	280	370	155	60	80	60	345	315	12 x M18	2	M12 x 1,75	11,5	250	180	15
<b>HRF/HRP 135 x 40</b>	138,0	131,0	280	370	155	60	80	60	345	315	12 x M18	2	M12 x 1,75	11,5	250	180	15
<b>HRF/HRP 135 x 50</b>	138,8	130,0	280	370	155	60	80	60	345	315	12 x M18	2	M12 x 1,75	11,5	250	180	15
<b>HRF/HRP 150 x 15</b>	151,1	148,5	320	412	171	65	80	70	385	355	12 x M18	3	M12 x 1,75	12,5	280	230	15
<b>HRF/HRP 150 x 20</b>	151,5	148,0	320	412	171	65	80	70	385	355	12 x M18	3	M12 x 1,75	12,5	280	230	15
<b>HRF/HRP 150 x 25</b>	151,9	147,5	320	412	171	65	80	70	385	355	12 x M18	3	M12 x 1,75	12,5	280	230	15
<b>HRF/HRP 150 x 30</b>	152,3	147,0	320	412	171	65	80	70	385	355	12 x M18	3	M12 x 1,75	12,5	280	230	15
<b>HRF/HRP 150 x 35</b>	152,6	146,5	320	412	171	65	80	70	385	355	12 x M18	3	M12 x 1,75	12,5	280	230	15
<b>HRF/HRP 150 x 40</b>	153,0	146,0	320	412	171	65	80	70	385	355	12 x M18	3	M12 x 1,75	12,5	280	230	15
<b>HRF/HRP 150 x 50</b>	153,8	145,0	320	412	171	65	80	70	385	355	12 x M18	3	M12 x 1,75	12,5	280	230	15
<b>HRF/HRP 180 x 15</b>	181,1	178,5	390	528	219	96	100	90	470	433	12 x M22	3	M12 x 1,75	15	340	250	15
<b>HRF/HRP 180 x 20</b>	181,5	178,0	390	528	219	96	100	90	470	433	12 x M22	3	M12 x 1,75	15	340	250	15
<b>HRF/HRP 180 x 25</b>	181,9	177,5	390	528	219	96	100	90	470	433	12 x M22	3	M12 x 1,75	15	340	250	15
<b>HRF/HRP 180 x 30</b>	182,3	177,0	390	528	219	96	100	90	470	433	12 x M22	3	M12 x 1,75	15	340	250	15
<b>HRF/HRP 180 x 35</b>	182,6	176,5	390	528	219	96	100	90	470	433	12 x M22	3	M12 x 1,75	15	340	250	15
<b>HRF/HRP 180 x 40</b>	183,0	176,0	390	528	219	96	100	90	470	433	12 x M22	3	M12 x 1,75	15	340	250	15
<b>HRF/HRP 180 x 50</b>	183,8	175,0	390	528	219	96	100	90	470	433	12 x M22	3	M12 x 1,75	15	340	250	15
<b>HRF/HRP 210 x 20</b>	211,5	208,0	440	570	235	100	100	100	530	490	12 x M24	3	M12 x 1,75	15	398	250	15
<b>HRF/HRP 210 x 25</b>	211,9	207,5	440	570	235	100	100	100	530	490	12 x M24	3	M12 x 1,75	15	398	250	15
<b>HRF/HRP 210 x 30</b>	212,3	207,0	440	570	235	100	100	100	530	490	12 x M24	3	M12 x 1,75	15	398	250	15
<b>HRF/HRP 210 x 35</b>	212,6	206,5	440	570	235	100	100	100	530	490	12 x M24	3	M12 x 1,75	15	398	250	15
<b>HRF/HRP 210 x 40</b>	213,0	206,0	440	570	235	100	100	100	530	490	12 x M24	3	M12 x 1,75	15	398	250	15
<b>HRF/HRP 210 x 50</b>	213,8	205,0	440	570	235	100	100	100	530	490	12 x M24	3	M12 x 1,75	15	398	250	15
<b>HRF/HRP 240 x 25</b>	241,9	237,5	490	600	250	100	100	100	580	540	16 x M24	3	M12 x 1,75	15	448	290	11,25
<b>HRF/HRP 240 x 30</b>	242,3	237,0	490	600	250	100	100	100	580	540	16 x M24	3	M12 x 1,75	15	448	290	11,25
<b>HRF/HRP 240 x 35</b>	242,6	236,5	490	600	250	100	100	100	580	540	16 x M24	3	M12 x 1,75	15	448	290	11,25
<b>HRF/HRP 240 x 40</b>	243,0	236,0	490	600	250	100	100	100	580	540	16 x M24	3	M12 x 1,75	15	448	290	11,25
<b>HRF/HRP 240 x 50</b>	243,8	235,0	490	600	250	100	100	100	580	540	16 x M24	3	M12 x 1,75	15	448	290	11,25

# Inverted roller screws ISR

## Concept

The inverted planetary roller screw provides powerful electro-mechanical actuation when compactness, low torque and high load capabilities are prerequisites.

The rollers, synchronized with the threaded shaft through toothed rings, translate along the nut. The application loads acting on the translating push tube transit through the planetary rollers to the rotating shaft or nut. Toothed rings and guides provide the rolling motion and the even circumferential position of the rollers, for near-perfect load distribution. The rings and guides also avoid any parasitic friction between the rollers.

## Application examples

The compact inverted roller screw, incorporated within an electro-mechanical actuator, can replace hydraulic or pneumatic actuation systems typically found in the following applications:

- Factory automation (for example, automotive assembly lines)
- Welding guns
- Portable high power tools
- Oil and gas subsea equipment
- Aerospace actuators



Design features	User benefits
Planetary roller screw concept without recirculation Leads as small as 2,4 mm, combined with the benefits of the robust planetary roller screw design	Long service life and increased reliability improve productivity Small leads achieved with robust threads, while providing high load carrying capacity and high axial stiffness Reduced requirements for electric motor torque to reach high load actuation
Either nut or shaft can be driven, the non-rotating and translating component acting directly as the push tube	Design flexibility Anti-rotation function can be easily integrated into the component acting as the push tube
Custom screw-to-motor attachments for easy integration Standard delivery without wipers	Compact, light weight solution with fewer parts for easy installation Guiding and sealing functions easily integrated on nut or shaft, resulting in high performance sealing
High speed and acceleration capability, similar to planetary roller screws	Preferred solutions for applications with high duty cycle and high cycle rates
Two versions are available: ISR with axial play IBR without backlash	Equipment stiffness and accuracy further increased when backlash is eliminated
Flexible production equipment	Custom designs to fit customer applications. Multiple dimensions can be created, starting from the standard assortment of planetary roller screws
Small lead associated to a relatively large nominal nut diameter	Low backdriving ability and even self locking solutions are possible

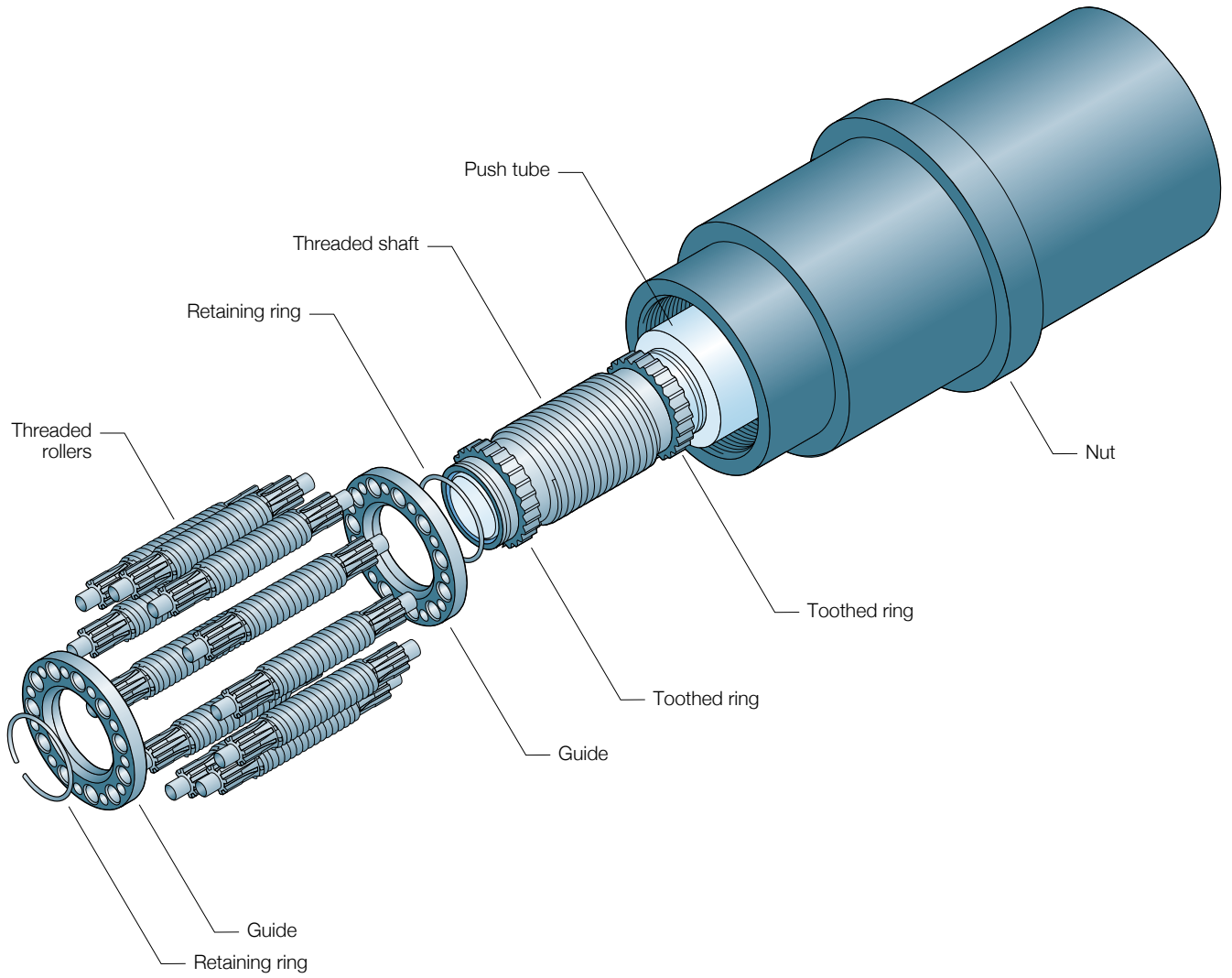

3

## ISR inverted roller screws

d 18 – 48 mm



Roller set of an inverted roller screw

Dimensions and technical characteristics							
$d_0$ mm	$D_0$	$P_h$	$C_a$ kN	$C_{0a}$	$\eta_p$ –	$\eta'_p$	
<b>18</b>	30	2,4	35,6	69,9	0,69	0,55	
	30	3	37,8	70,9	0,73	0,63	
	30	4	36,6	61,2	0,77	0,70	
	30	5	37,8	59,2	0,80	0,75	
	30	6	40,4	61,9	0,82	0,78	
<b>21</b>	35	2,4	55,5	102	0,66	0,48	
	35	3	59,6	105	0,7	0,57	
	35	4	63,3	104	0,75	0,67	
	35	5	61,5	91,8	0,78	0,72	
	35	6	64,2	92,2	0,8	0,75	
<b>24</b>	40	2,4	63,7	118	0,63	0,41	
	40	3	67,2	119	0,68	0,53	
	40	4	72	119	0,73	0,63	
	40	5	75,3	118	0,76	0,68	
	40	6	74,5	109	0,79	0,73	
<b>30</b>	50	2,4	93,2	195	0,58	0,28	
	50	3	99,2	198	0,63	0,41	
	50	4	105	194	0,69	0,55	
	50	5	111	197	0,73	0,63	
	50	6	117	200	0,76	0,68	
<b>39</b>	65	2,4	135	311	0,52	0,08	
	65	3	143	311	0,57	0,25	
	65	4	153	312	0,64	0,44	
	65	5	161	310	0,68	0,53	
	65	6	169	314	0,72	0,61	
<b>48</b>	80	2,4	209	564	0,47	0	
	80	3	221	567	0,52	0,08	
	80	4	234	557	0,59	0,31	
	80	5	247	554	0,64	0,44	
	80	6	259	559	0,68	0,53	

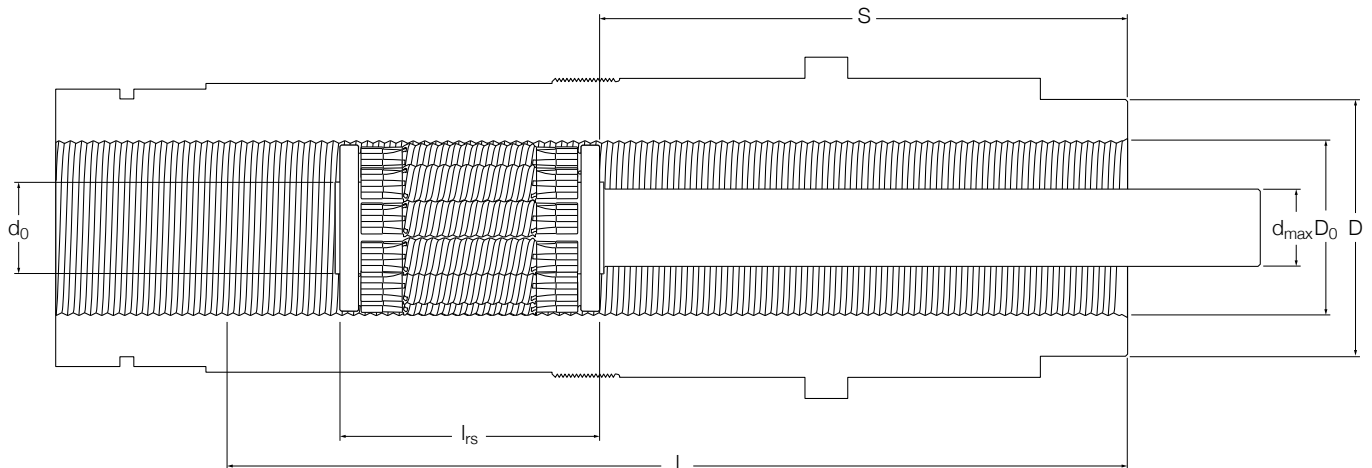

Designation	Maximum axial play $S_{ap}$ mm	Recommended minimum nut outer diameter D	Maximum push tube outer diameter <sup>1)</sup> $d_{max}$	Maximum stroke S	Length of roller set $l_{rs}$
-					
ISR/IBR 18 x 2,4R3	0,02	38	16	65 <sup>2)</sup>	50
ISR/IBR 18 x 3R3	0,02	38	16	60 <sup>2)</sup>	50
ISR/IBR 18 x 4R3	0,02	38	16	55 <sup>2)</sup>	50
ISR/IBR 18 x 5R3	0,04	38	16	50 <sup>2)</sup>	50
ISR/IBR 18 x 6R3	0,04	38	16	45 <sup>2)</sup>	50
ISR/IBR 21 x 2,4R3	0,02	45	18	84 <sup>2)</sup>	56
ISR/IBR 21 x 3R3	0,02	45	18	79 <sup>2)</sup>	56
ISR/IBR 21 x 4R3	0,02	45	18	74 <sup>2)</sup>	56
ISR/IBR 21 x 5R3	0,04	45	18	69 <sup>2)</sup>	56
ISR/IBR 21 x 6R3	0,04	45	18	64 <sup>2)</sup>	56
ISR/IBR 24 x 2,4R3	0,02	50	21	210	65
ISR/IBR 24 x 3R3	0,02	50	21	170	65
ISR/IBR 24 x 4R3	0,02	50	21	110	65
ISR/IBR 24 x 5R3	0,04	50	21	80	65
ISR/IBR 24 x 6R3	0,04	50	21	75	65
ISR/IBR 30 x 2,4R3	0,02	60	27	210	75
ISR/IBR 30 x 3R3	0,02	60	27	210	75
ISR/IBR 30 x 4R3	0,02	60	27	210	75
ISR/IBR 30 x 5R3	0,04	60	27	200	75
ISR/IBR 30 x 6R3	0,04	60	27	200	75
ISR/IBR 39 x 2,4R3	0,02	75	36	195	90
ISR/IBR 39 x 3R3	0,02	75	36	195	90
ISR/IBR 39 x 4R3	0,02	75	36	195	90
ISR/IBR 39 x 5R3	0,04	75	36	195	90
ISR/IBR 39 x 6R3	0,04	75	36	195	90
ISR/IBR 48 x 2,4R3	0,02	90	44	171	114
ISR/IBR 48 x 3R3	0,02	90	44	171	114
ISR/IBR 48 x 4R3	0,02	90	44	171	114
ISR/IBR 48 x 5R3	0,04	90	44	171	114
ISR/IBR 48 x 6R3	0,04	90	44	171	114

<sup>1)</sup> Recommended maximum push tube diameter for standard inverted roller screws. For additional information about large push tube diameters, please contact your local Ewellix representative

<sup>2)</sup> For additional information about longer strokes, please contact your local Ewellix representative

# Rotating nut with planetary roller screws SRR

## Concept

A rotating nut planetary roller screw assembly is designed to function like an electro-mechanical cylinder, and is recommended for applications where space is limited.

The basic assembly consists of a housing, two angular contact ball bearings and a roller screw nut. In the case of direct drive, a customer supplied hollow motor drives the screw nut. In the case of indirect drive, a customer supplied pulley or gear, attached to the back of the roller screw assembly is needed to drive the nut. The rotation of the nut translates the screw shaft which operates as a push tube of an electro-mechanical cylinder. The screw shaft must be fitted with an anti-rotation device and must be precisely guided.

## Important:

Ewellix recommends that the roller screw nut be relubricated by regular injection of lubricant through an axial hole and a radial hole drilled in the roller screw shaft<sup>1)</sup>.

Customers are responsible for sourcing and assembling the motor and/or drive train and frame holding the bearings housing.

## Application examples

- Production processes in automotive industry (servo-presses, tube bending, forming, locking devices, etc.)
- Process in the injection moulding industry (part ejection)
- Short stroke and oscillating applications

Design features	User benefits
Planetary roller screws with a nut already fitted into a bearing housing	Convenience of a roller screw and integrated support function for easy design and assembly
Maximum $n_{d_0} = 160\,000$ and acceleration up to $12\,000\text{ rad/s}^2$	Ideal combination of high load carrying capacity, speed and acceleration for heavy duty applications and intensive cycling
72 series angular contact ball bearings mounted in the housing are fitted with the nut and then adjusted for preload	Length saving solution ready to incorporate into application. Simplified engineering for machine builders
Bearings in back-to-back preloaded arrangement	Robust and stiff bearing arrangement to accommodate moment loads from the power transmission
2 garter seals (2 shields for size $d_0 = 60\text{ mm}$ ) protect the bearings against contaminants, making these assemblies relubrication-free under normal operating conditions	Durable assembly for operation in difficult environments
Wiper seals at each end of the nut of a standard assembly help to protect the nut from contaminants	
A grease fitting for the bearings is located on the outside surface of the housing. Standard grease is Ewellix LGEP2. Specific grease is on request	Easy maintenance
Roller screw nut relubricated through conduits drilled in the screw shaft	Independent relubrication for the bearings and for the roller screw
Two versions are available: <ul style="list-style-type: none"> <li>• SRR with axial play</li> <li>• BRR without backlash</li> </ul>	Stiffness and running accuracy are further improved when a roller screw without backlash is selected

<sup>1)</sup> For technical assistance regarding the roller screw nut relubrication, please contact your local Ewellix representative

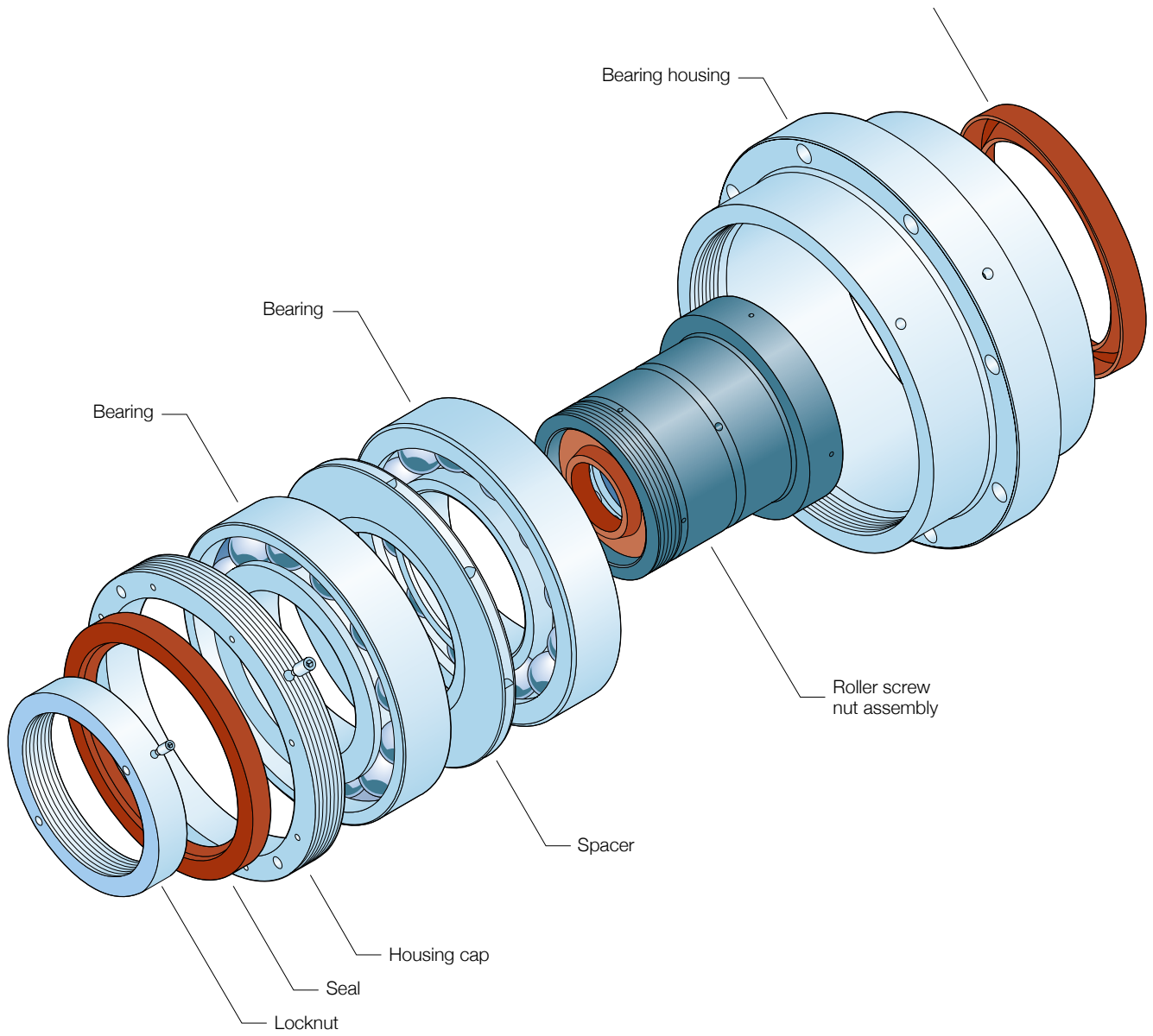

3

SRR/BRR planetary roller screws with rotating nut

d 25 – 60 mm



Standard SRR



Components assembly

Dimensions and technical characteristics												
$d_0$	$P_h$	$L_{tp}$	$C_a$	$C_{0a}$	$\eta$	$\eta'$	$S_{ap}$	$m_n$	$m_s$	$I_{nn}$	$Z_n$	$Z_s$
			kN		-		mm	kg	kg/m	kgmm <sup>2</sup>	cm <sup>3</sup>	cm <sup>3</sup> /m
<b>25</b>	5	1 650	68,4	122	0,87	0,85	0,02	7	3,9	1 100	10,2	11
	10	1 650	78,5	118	0,89	0,88	0,04	7	3,9	1 100	10,2	11
	15	1 650	85,6	120	0,87	0,85	0,07	7	3,9	1 100	10,2	11
<b>30</b>	5	2 000	91,9	178	0,86	0,83	0,02	12	5,6	2 900	13,7	13,2
	10	2 000	106	174	0,89	0,88	0,04	12	5,6	2 900	13,7	13,2
	15	2 000	119	181	0,88	0,87	0,07	12	5,6	2 900	13,7	13,2
	20	2 000	123	177	0,86	0,83	0,07	12	5,6	2 900	13,7	13,2
<b>39</b>	5	2 650	129	269	0,83	0,80	0,02	20	9,4	10 500	27,9	17,1
	10	2 650	153	270	0,88	0,87	0,04	20	9,4	10 500	27,9	17,1
	15	2 650	168	273	0,89	0,88	0,07	20	9,4	10 500	27,9	17,1
	20	2 650	173	261	0,88	0,87	0,07	20	9,4	10 500	27,9	17,1
	25	2 650	175	249	0,86	0,84	0,07	20	9,4	10 500	27,9	17,1
<b>48</b>	5	3 300	198	482	0,81	0,76	0,02	37	14,2	28 000	54	21,1
	10	3 300	232	475	0,87	0,85	0,04	37	14,2	28 000	54	21,1
	15	3 300	258	486	0,89	0,88	0,07	37	14,2	28 000	54	21,1
	20	3 300	266	462	0,89	0,88	0,07	37	14,2	28 000	54	21,1
	25	3 300	286	491	0,88	0,87	0,07	37	14,2	28 000	54	21,1
<b>60</b>	10	4 250	339	780	0,86	0,83	0,04	100	22,2	85 000	103	26,4
	15	4 250	373	783	0,88	0,87	0,07	100	22,2	85 000	103	26,4
	20	4 250	395	786	0,89	0,88	0,07	100	22,2	85 000	103	26,4

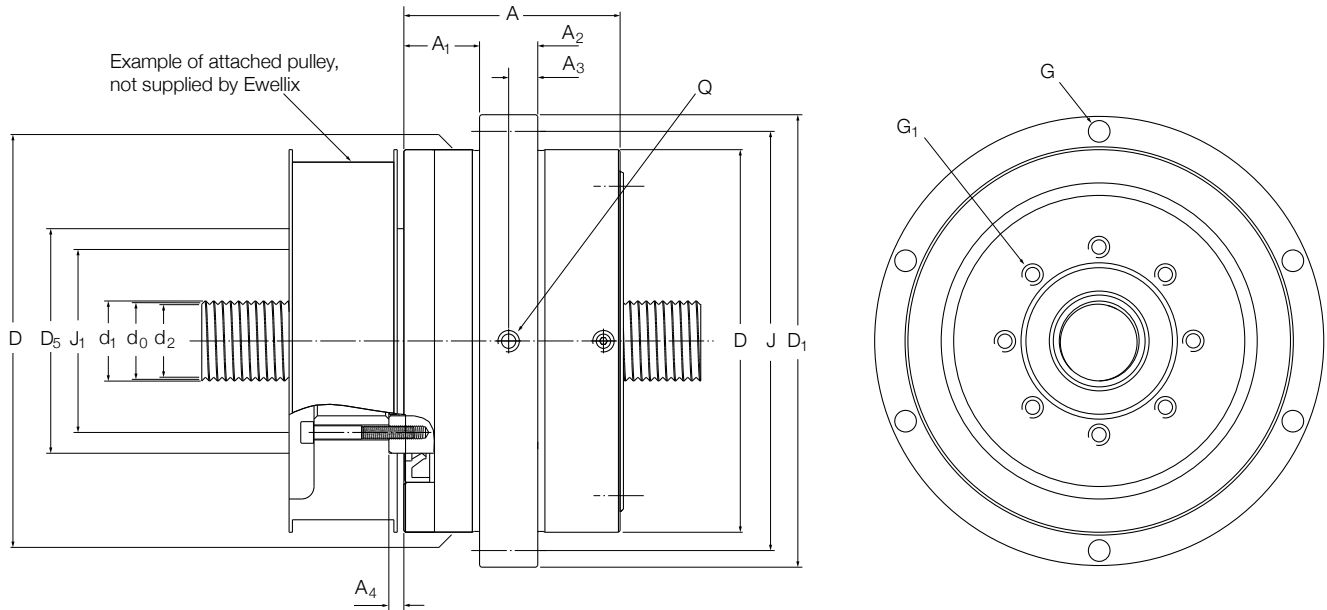

**Designation**

**Dimensions**

	d <sub>1</sub>	d <sub>2</sub>	D g6/H7	A h12	A <sub>1</sub>	A <sub>2</sub>	A <sub>3</sub>	A <sub>4</sub> <sup>1)</sup>	D <sub>1</sub>	J	D <sub>5</sub> g7	J <sub>1</sub>	G	G <sub>1</sub>	Q
-	mm														
<b>SRR/BRR 25 x 5</b>	25,4	24,3	120	81,5	28	25	12,5	6,5	153	137	70	58	6 x Ø9	8 x M6	M6
<b>SRR/BRR 25 x 10</b>	25,8	23,8	120	81,5	28	25	12,5	6,5	153	137	70	58	6 x Ø9	8 x M6	M6
<b>SRR/BRR 25 x 15</b>	26,2	23,2	120	81,5	28	25	12,5	6,5	153	137	70	58	6 x Ø9	8 x M6	M6
<b>SRR/BRR 30 x 5</b>	30,4	29,4	150	91,5	30	25	12,5	7,5	190	170	85	70	6 x Ø11	8 x M6	M8 x 1
<b>SRR/BRR 30 x 10</b>	30,8	28,8	150	91,5	30	25	12,5	7,5	190	170	85	70	6 x Ø11	8 x M6	M8 x 1
<b>SRR/BRR 30 x 15</b>	31,2	28,3	150	91,5	30	25	12,5	7,5	190	170	85	70	6 x Ø11	8 x M6	M8 x 1
<b>SRR/BRR 30 x 20</b>	31,5	27,6	150	91,5	30	25	12,5	7,5	190	170	85	70	6 x Ø11	8 x M6	M8 x 1
<b>SRR/BRR 39 x 5</b>	39,4	38,4	180	109,5	34	35	17,5	12,5	222	202	110	90	6 x Ø13	8 x M8	M8 x 1
<b>SRR/BRR 39 x 10</b>	39,8	37,9	180	109,5	34	35	17,5	12,5	222	202	110	90	6 x Ø13	8 x M8	M8 x 1
<b>SRR/BRR 39 x 15</b>	40,2	37,3	180	109,5	34	35	17,5	12,5	222	202	110	90	6 x Ø13	8 x M8	M8 x 1
<b>SRR/BRR 39 x 20</b>	40,5	36,7	180	109,5	34	35	17,5	12,5	222	202	110	90	6 x Ø13	8 x M8	M8 x 1
<b>SRR/BRR 39 x 25</b>	40,9	36,1	180	109,5	34	35	17,5	12,5	222	202	110	90	6 x Ø13	8 x M8	M8 x 1
<b>SRR/BRR 48 x 5</b>	48,4	47,4	230	130	45,5	35	17,5	9	272	252	135	110	8 x Ø13	8 x M8	M8 x 1
<b>SRR/BRR 48 x 10</b>	48,8	46,9	230	130	45,5	35	17,5	9	272	252	135	110	8 x Ø13	8 x M8	M8 x 1
<b>SRR/BRR 48 x 15</b>	49,2	46,3	230	130	45,5	35	17,5	9	272	252	135	110	8 x Ø13	8 x M8	M8 x 1
<b>SRR/BRR 48 x 20</b>	49,5	45,8	230	130	45,5	35	17,5	9	272	252	135	110	8 x Ø13	8 x M8	M8 x 1
<b>SRR/BRR 48 x 25</b>	49,9	45,2	230	130	45,5	35	17,5	9	272	252	135	110	8 x Ø13	8 x M8	M8 x 1
<b>SRR/BRR 60 x 10</b>	60,8	58,9	320	189	70,5	45	22,5	10	380	350	160	135	8 x Ø17,5	8 x M8	M8 x 1
<b>SRR/BRR 60 x 15</b>	61,2	58,4	320	189	70,5	45	22,5	10	380	350	160	135	8 x Ø17,5	8 x M8	M8 x 1
<b>SRR/BRR 60 x 20</b>	61,5	57,8	320	189	70,5	45	22,5	10	380	350	160	135	8 x Ø17,5	8 x M8	M8 x 1

# Recirculating roller screws SV

## Concept

Recirculating roller screws provide the ideal combination of load carrying capacity, fine resolution, positioning accuracy and axial stiffness for ultra precision driving solutions.

The small leads and small helix angle can provide a low back-driving capability, or even self-locking ability for certain sizes of recirculating roller screws, in combination with low rolling friction.

## Application examples

- Medical
- Laboratory equipment
- Semi-conductor industry
- Telescopes
- Satellites
- Precision grinders

Design features	User benefits
Absence of small parts compared to small lead ball screw	Highly robust and durable
Nominal diameters from 8 to 125 mm	Wide standard assortment to fit most applications
Standard leads from 1 mm to 5 mm	Ideal combination of precise positioning accuracy, high load carrying capacity, maximum axial stiffness, and low torque requirements Precise resolution of movement Good repeatability with small displacements
Shaft lengths up to 8 000 mm	Longer shaft lengths available on request
Maximum $n_{d_1} = 30\,000$ for nominal diameters $d_1 \leq 25$ mm Maximum $n_{d_1} = 20\,000$ for nominal diameters $d_1 > 25$ mm Accelerations up to $4\,000$ rad/s <sup>2</sup>	Long service life
High dynamic load carrying capacity up to 756 kN	
High static load carrying capacity up to 2 770 kN	Ability to accommodate heavy shock loads without raceway damage
Roller retention for nut and shaft disassembly (except for diameters $d_1 < 16$ mm)	Easy roller screw assembly
Optional support bearings	Support bearings simplify design, assembly, and ordering process
Three standard versions are available: <ul style="list-style-type: none"> <li>• SV with axial play</li> <li>• BV without backlash</li> <li>• PV with preloaded split nut</li> </ul>	Running accuracy and stiffness further improved without backlash or with preload
Flexible equipment	Custom designs e.g. left hand threads available on request

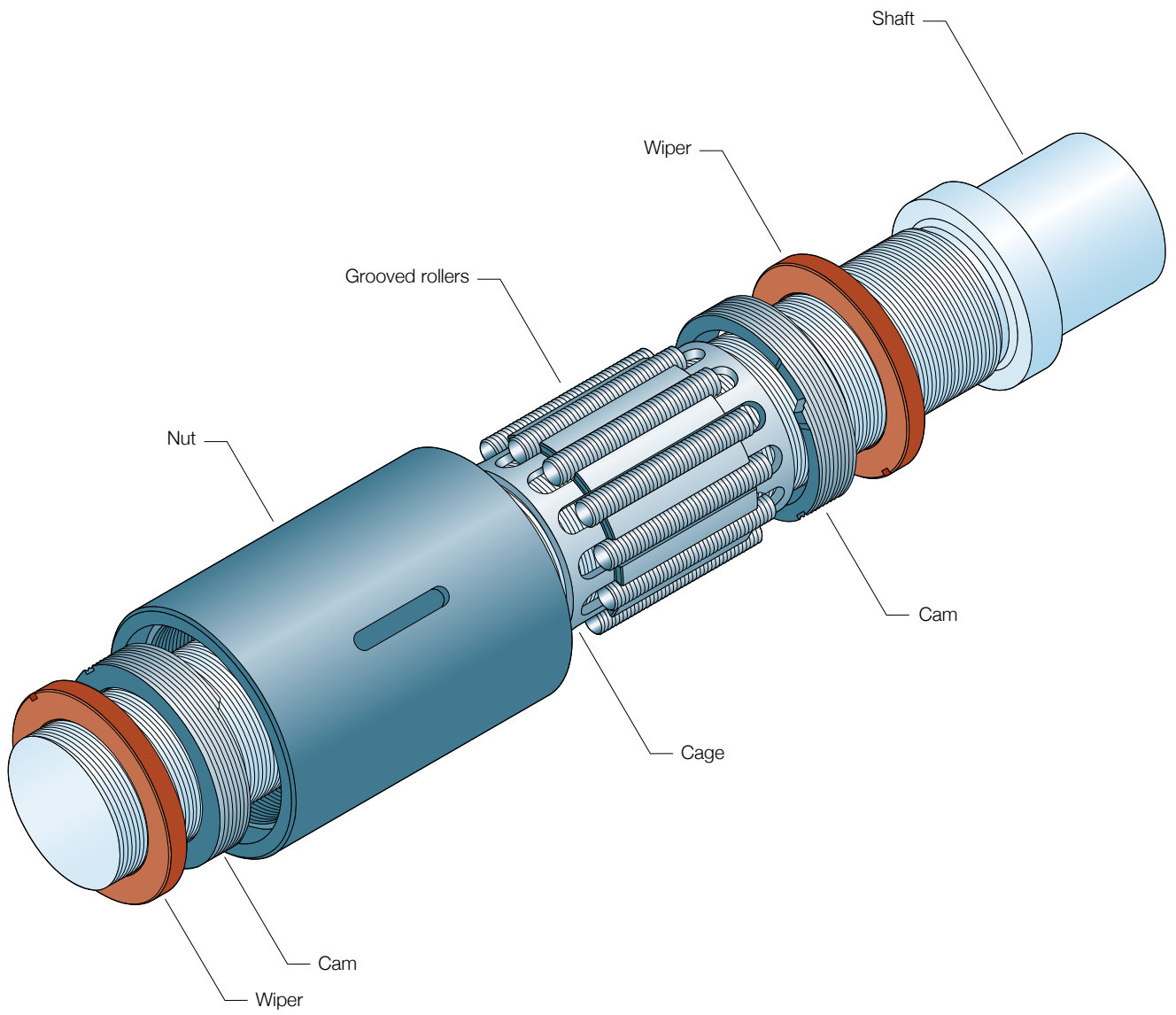

3

## SVC/BVC recirculating roller screws with cylindrical nut

d 8 – 125 mm



Standard SVC



Grooved rollers



Components assembly

### Dimensions and technical characteristics

d <sub>1</sub>	P <sub>n</sub>	L <sub>sp</sub> <sup>1)</sup>	C <sub>a</sub>	C <sub>oa</sub>	η	η'	S <sub>ap</sub>	T <sub>be</sub>	m <sub>n</sub>	m <sub>s</sub>	I <sub>s</sub>	I <sub>nn</sub>	I <sub>ns</sub>	Z <sub>n</sub>	Z <sub>s</sub>
			kN		–		mm	Nm	kg	kg/m	kgmm <sup>2</sup> /m	kgmm <sup>2</sup>		cm <sup>3</sup>	cm <sup>3</sup> /m
8	1	500	8,5	11	0,83	0,79	0,02	0,1	0,1	0,36	2,6	3,6	0,1	0,72	4
10	1	650	8,95	11,4	0,80	0,75	0,02	0,1	0,1	0,57	6,7	5	0,1	0,95	5
	2	650	8,95	11,4	0,87	0,85	0,02	0,1	0,1	0,57	6,7	5	0,1	0,95	5
12	1	750	10,3	14	0,78	0,71	0,02	0,1	0,1	0,84	14,2	6,7	0,1	1,08	6
	2	750	10,3	14	0,86	0,83	0,02	0,1	0,1	0,84	14,2	6,7	0,1	1,08	6
16	1	1 050	11,5	16,8	0,73	0,63	0,02	0,1	0,1	1,51	46,2	14	0,3	1,43	8
	2	1 050	11,5	16,8	0,83	0,79	0,02	0,1	0,1	1,51	46,2	14	0,3	1,43	8
20	1	1 300	18,5	36,6	0,69	0,54	0,02	0,18	0,2	2,38	115	29,8	0,8	1,9	9
	2	1 300	18,5	36,6	0,80	0,75	0,02	0,2	0,2	2,38	115	29,8	0,8	1,9	9
25	1	1 650	32,9	68,4	0,64	0,43	0,02	0,35	0,3	3,75	285	79,3	2,5	3,57	11
	2	1 650	32,9	68,4	0,77	0,70	0,02	0,4	0,3	3,75	285	79,3	2,5	3,57	11
32	1	2 150	64,3	159	0,58	0,28	0,02	0,5	0,6	6,18	773	280	9,1	6,92	15
	2	2 150	64,3	159	0,73	0,63	0,02	0,5	0,6	6,18	773	280	9,1	6,92	15
40	1	2 700	79,1	232	0,53	0,11	0,02	0,7	1,2	9,69	1 900	879	18,8	9,57	18
	2	2 700	49,9	117	0,69	0,54	0,04	0,7	1,2	9,52	1 840	951	20	13,6	18
50	1	3 500	190	544	0,47	0	0,02	1,2	2	15,0	4 550	2 190	76	24,9	22
	2	3 500	98,1	249	0,64	0,43	0,04	1,2	2	15,0	4 550	2 190	68,6	24,4	22
	3	3 500	153	443	0,72	0,61	0,04	1,2	2	15,0	4 550	2 190	88,1	24	22
	4	3 500	98,1	249	0,77	0,70	0,04	1,2	2	15,0	4 550	2 190	68,6	24,4	22
63	2	4 500	186	534	0,59	0,29	0,04	1,8	3,8	23,9	11 600	6 460	230	44,3	28
	4	4 500	186	534	0,73	0,63	0,04	2,0	3,8	23,9	11 600	6 460	230	44,3	28
80	4	6 000	325	888	0,69	0,54	0,07	3,0	12,5	38,1	29 400	38 900	1 290	166	36
100	5	8 000	469	1 376	0,69	0,54	0,07	4,5	22,8	59,51	71 800	108 000	4 000	308	44
125	5	8 000	756	2 770	0,64	0,43	0,07	7,0	46,1	93,66	178 000	342 000	11 800	520	55

■ Preferred range

<sup>1)</sup> For BV (backlash elimination), maximal length can be shorter

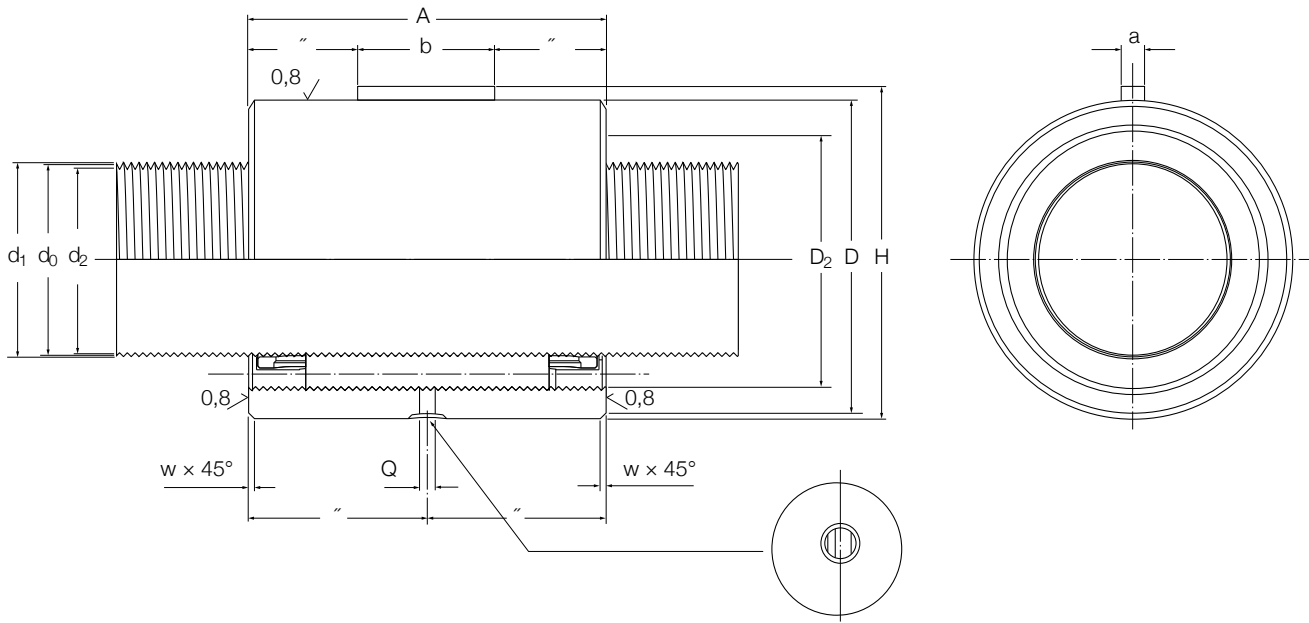

Designation	Dimensions										
	d <sub>0</sub>	d <sub>2</sub>	D g6/H7	A with wiper recesses h12	A without wiper recesses h12	w	a h9	b	H	Q	D <sub>2</sub>
-	mm										
SVC/BVC 8 x 1	7,7	7,1	20	40	31	0,2	2	12	20,8	5	16,5
SVC/BVC 10 x 1	9,7	9,1	22	40	31	0,2	2	12	22,8	5	18,5
SVC/BVC 10 x 2	9,7	9,1	22	40	31	0,2	2	12	22,8	5	18,5
SVC/BVC 12 x 1	11,7	11,1	24	40	31	0,2	2	12	24,8	5	20,5
SVC/BVC 12 x 2	11,7	11,1	24	40	31	0,2	2	12	24,8	5	20,5
SVC/BVC 16 x 1	15,7	15,1	29	40	31	0,5	3	12	30,2	5	25
SVC/BVC 16 x 2	15,7	15,1	29	40	31	0,5	3	12	30,2	5	25
SVC/BVC 20 x 1	19,7	19,1	34	45	37	0,5	3	16	35,2	5	28,5
SVC/BVC 20 x 2	19,7	19,1	34	45	37	0,5	3	16	35,2	5	28,5
SVC/BVC 25 x 1	24,7	24,1	42	54	44	0,5	4	20	43,5	5	36
SVC/BVC 25 x 2	24,7	24,1	42	54	44	0,5	4	20	43,5	5	36
SVC/BVC 32 x 1	31,7	31,1	54	67	57	1	4	25	55,5	5	45
SVC/BVC 32 x 2	31,7	31,1	54	67	57	1	4	25	55,5	5	45
SVC/BVC 40 x 1	39,7	39,1	68	75	63	1	5	32	70	5	55
SVC/BVC 40 x 2	39,3	38,2	68	84	72	1	5	32	70	5	57
SVC/BVC 50 x 1	49,7	49,1	82	101	85	1	6	32	84,5	8	70
SVC/BVC 50 x 2	49,3	48,7	82	101	85	1	6	32	84,5	8	70
SVC 50 x 3	49,5	48,6	82	108	92	1,5	6	35	84,5	8	70
SVC 50 x 4	49,3	48,2	82	101	85	1	6	32	84,5	8	70
SVC 63 x 2	62,3	61,2	103	120	104	1	6	40	105,5	8	94
SVC 63 x 4	62,3	61,2	103	120	104	1	6	40	105,5	8	94
SVC 80 x 4	78,6	76,4	141	197	175	1,5	8	63	144	10	120
SVC 100 x 5	98,3	95,5	175	237	205	2	10	80	178	10	150
SVC 125 x 5	123,3	120,5	220	282	250	3	12	100	223	12	185

## SVF/BVF recirculating roller screws with flanged nut

d 8 – 125 mm

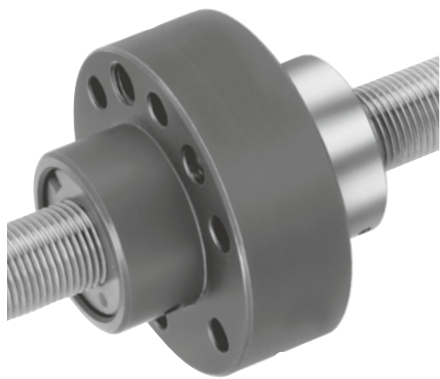

Standard SVF



Grooved rollers



Components assembly

### Dimensions and technical characteristics

d <sub>1</sub>	P <sub>h</sub>	L <sub>ip</sub> <sup>1)</sup>	C <sub>a</sub>	C <sub>oa</sub>	η	η'	S <sub>ap</sub>	T <sub>be</sub>	m <sub>n</sub>	m <sub>s</sub>	I <sub>s</sub>	I <sub>nn</sub>	I <sub>ns</sub>	Z <sub>n</sub>	Z <sub>s</sub>
			kN		-		mm	Nm	kg	kg/m	kgmm <sup>2</sup> /m	kgmm <sup>2</sup>		cm <sup>3</sup>	cm <sup>3</sup> /m
<b>8</b>	1	500	8,5	11	0,83	0,79	0,02	0,02	0,2	0,36	2,6	47,9	0,1	0,72	4
<b>10</b>	1	650	8,95	11,4	0,80	0,75	0,02	0,03	0,2	0,57	6,7	47	0,1	0,95	5
	2	650	8,95	11,4	0,87	0,85	0,02	0,03	0,2	0,57	6,7	47	0,1	0,95	5
<b>12</b>	1	750	10,3	14	0,78	0,71	0,02	0,05	0,2	0,84	14,2	63,5	0,1	1,08	6
	2	750	10,3	14	0,86	0,83	0,02	0,05	0,2	0,84	14,2	63,5	0,1	1,08	6
<b>16</b>	1	1 050	11,5	16,8	0,73	0,63	0,02	0,1	0,3	1,51	46,2	100	0,3	1,43	8
	2	1 050	11,5	16,8	0,83	0,79	0,02	0,1	0,3	1,51	46,2	100	0,3	1,43	8
<b>20</b>	1	1 300	18,5	36,6	0,69	0,54	0,02	0,18	0,4	2,38	115	192	0,8	1,9	9
	2	1 300	18,5	36,6	0,80	0,75	0,02	0,2	0,4	2,38	115	192	0,8	1,9	9
<b>25</b>	1	1 650	32,9	68,4	0,64	0,43	0,02	0,35	0,6	3,75	285	416	2,5	3,57	11
	2	1 650	32,9	68,4	0,77	0,70	0,02	0,4	0,6	3,75	285	416	2,5	3,57	11
<b>32</b>	1	2 150	64,3	159	0,58	0,28	0,02	0,5	1,2	6,18	773	1 110	9,1	6,92	15
	2	2 150	64,3	159	0,73	0,63	0,02	0,5	1,2	6,18	773	1 110	9,1	6,92	15
<b>40</b>	1	2 700	79,1	232	0,53	0,11	0,02	0,7	2,1	9,69	1 900	3 120	18,8	9,57	18
	2	2 700	49,9	117	0,69	0,54	0,04	0,7	2,2	9,52	1 840	3 200	20	13,6	18
<b>50</b>	1	3 500	190	544	0,47	0	0,02	1,2	3,7	15	4 550	8 190	76	24,9	22
	2	3 500	98,1	249	0,64	0,43	0,04	1,2	3,7	15	4 550	8 190	68,6	24,4	22
	3	3 500	153	443	0,72	0,61	0,04	1,2	3,7	15	4 550	8 050	88,1	24	22
	4	3 500	98,1	249	0,77	0,70	0,04	1,2	3,7	15	4 550	8 190	68,6	24,4	22
<b>63</b>	2	4 500	186	534	0,59	0,29	0,04	1,8	6,4	23,9	11 600	20 100	230	44,3	28
	4	4 500	186	534	0,73	0,63	0,04	2,0	6,4	23,9	11 600	20 100	230	44,3	28
<b>80</b>	4	6 000	325	888	0,69	0,54	0,07	3,0	17,8	38,1	29 400	92 600	1 290	166	36
<b>100</b>	5	8 000	469	1 376	0,69	0,54	0,07	4,5	33,1	59,5	71 800	256 000	4 000	308	44
<b>125</b>	5	8 000	756	2 770	0,64	0,43	0,07	7,0	62,3	93,7	178 000	733 000	11 800	520	55

<sup>1)</sup> For BV (backlash elimination), maximal length can be shorter

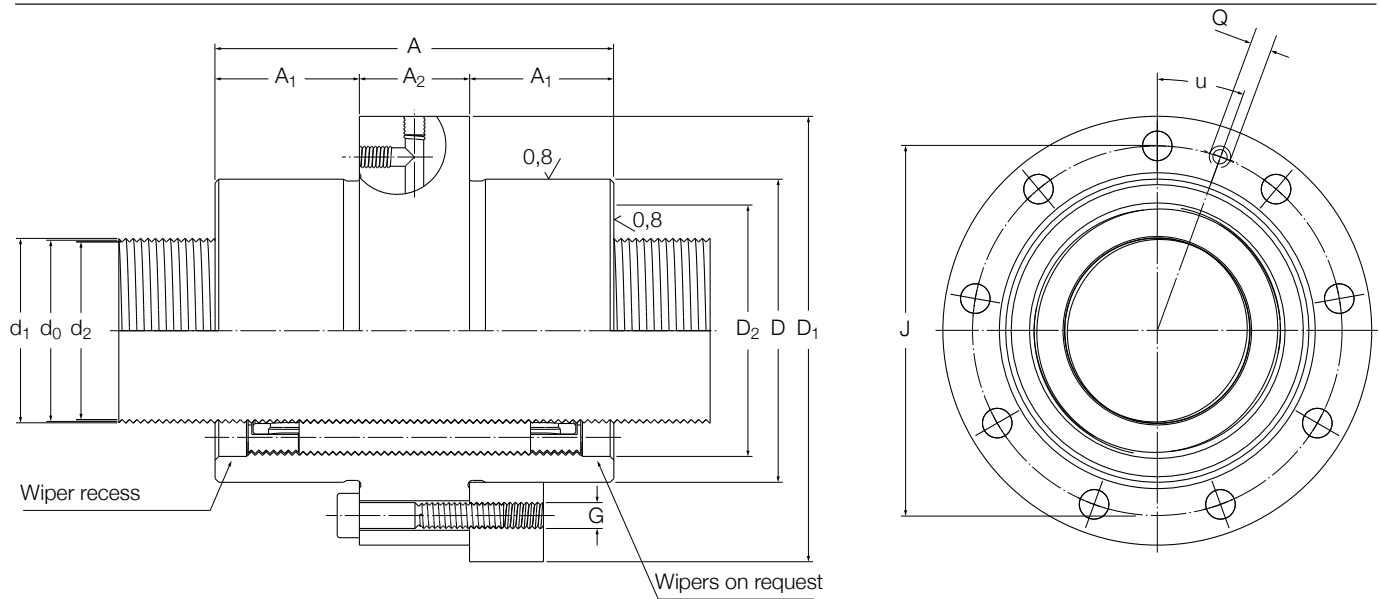

Designation	Dimensions											
	d <sub>0</sub>	d <sub>2</sub>	D g6/H7	A with wiper recesses h12	A <sub>1</sub> h12	A <sub>2</sub>	D <sub>1</sub> js12	J	G	Q	D <sub>2</sub>	u
-	mm											
<b>SVF/BVF 8 x 1</b>	7,7	7,1	22	40	12	16	43	33	6 x M4	M6	16,5	30
<b>SVF/BVF 10 x 1</b>	9,7	9,1	22	40	12	16	43	33	6 x M4	M6	18,5	30
<b>SVF/BVF 10 x 2</b>	9,7	9,1	22	40	12	16	43	33	6 x M4	M6	18,5	30
<b>SVF/BVF 12 x 1</b>	11,7	11,1	25	40	12	16	46	36	6 x M4	M6	20,5	30
<b>SVF/BVF 12 x 2</b>	11,7	11,1	25	40	12	16	46	36	6 x M4	M6	20,5	30
<b>SVF/BVF 16 x 1</b>	15,7	15,1	30	40	12	16	51	41	6 x M4	M6	25	30
<b>SVF/BVF 16 x 2</b>	15,7	15,1	30	40	12	16	51	41	6 x M4	M6	25	30
<b>SVF/BVF 20 x 1</b>	19,7	19,1	35	45	13,5	18	58	46	6 x M5	M6	28,5	30
<b>SVF/BVF 20 x 2</b>	19,7	19,1	35	45	13,5	18	58	46	6 x M5	M6	28,5	30
<b>SVF/BVF 25 x 1</b>	24,7	24,1	45	54	18	18	68	56	6 x M5	M6	36	30
<b>SVF/BVF 25 x 2</b>	24,7	24,1	45	54	18	18	68	56	6 x M5	M6	36	30
<b>SVF/BVF 32 x 1</b>	31,7	31,1	56	67	23,5	20	84	70	6 x M6	M6	45	30
<b>SVF/BVF 32 x 2</b>	31,7	31,1	56	67	23,5	20	84	70	6 x M6	M6	45	30
<b>SVF/BVF 40 x 1</b>	39,7	39,1	68	75	24	27	102	85	6 x M8	M6	55	30
<b>SVF/BVF 40 x 2</b>	39,3	38,2	68	84	28,5	27	102	85	6 x M8	M6	57	30
<b>SVF/BVF 50 x 1</b>	49,7	49,1	82	101	34	33	124	102	6 x M10	M6	70	30
<b>SVF/BVF 50 x 2</b>	49,3	48,7	82	101	34	33	124	102	6 x M10	M6	70	30
<b>SVF 50 x 3</b>	49,5	48,6	82	108	37,5	33	124	102	6 x M10	M6	70	30
<b>SVF 50 x 4</b>	49,3	48,2	82	101	34	33	124	102	6 x M10	M6	70	30
<b>SVF 63 x 2</b>	62,3	61,2	105	120	43,5	33	150	127	6 x M12	M8 x 1	94	30
<b>SVF 63 x 4</b>	62,3	61,2	105	120	43,5	33	150	127	6 x M12	M8 x 1	94	30
<b>SVF 80 x 4</b>	78,6	76,4	140	197	76	45	200	170	8 x M16	M8 x 1	120	22,5
<b>SVF 100 x 5</b>	98,3	95,5	180	237	93,5	50	240	210	12 x M16	M8 x 1	150	15
<b>SVF 125 x 5</b>	123,3	120,5	220	282	113,5	55	310	270	12 x M18	M8 x 1	185	15

## PVU preloaded recirculating roller screws with cylindrical nut

d 8 – 125 mm



Standard PVU



Grooved rollers



Components assembly

### Dimensions and technical characteristics

d <sub>1</sub>	P <sub>h</sub>	L <sub>tp</sub>	C <sub>a</sub>	C <sub>0a</sub>	η	η'	R <sub>ng</sub>	R <sub>nr</sub>	T <sub>pr</sub>	F <sub>pr</sub>	m <sub>n</sub>	m <sub>s</sub>	I <sub>s</sub>	I <sub>nn</sub>	I <sub>ns</sub>	Z <sub>n</sub>	Z <sub>s</sub>	
			kN		-		N/μm		-	Nm	N	kg	kg/m	kgmm <sup>2</sup> /m	kgmm <sup>2</sup>		cm <sup>3</sup>	cm <sup>3</sup> /m
<b>8</b>	1	400	4,88	5,51	0,83	0,79	140	190	0,05	770	0,1	0,36	2,6	3,6	0,1	0,72	4	
<b>10</b>	1	500	5,14	5,7	0,80	0,75	138	185	0,07	820	0,1	0,57	6,7	5	0,1	0,95	5	
	2	500	5,14	5,7	0,87	0,85	138	185	0,07	820	0,1	0,57	6,7	5	0,1	0,95	5	
<b>12</b>	1	600	5,96	7	0,78	0,71	159	215	0,1	940	0,1	0,84	14,2	6,7	0,1	1,08	6	
	2	600	5,96	7	0,86	0,83	159	215	0,1	940	0,1	0,84	14,2	6,7	0,1	1,08	6	
<b>16</b>	1	825	6,71	8,42	0,73	0,63	182	245	0,15	1 060	0,1	1,51	46,2	14	0,3	1,43	8	
	2	825	6,71	8,42	0,83	0,79	182	245	0,15	1 060	0,1	1,51	46,2	14	0,3	1,43	8	
<b>20</b>	1	1 050	10,6	18,3	0,69	0,54	362	490	0,2	1 430	0,2	2,38	115	29,8	0,8	1,9	9	
	2	1 050	10,6	18,3	0,80	0,75	362	490	0,3	1 430	0,2	2,38	115	29,8	0,8	1,9	9	
<b>25</b>	1	1 300	18,9	34,2	0,64	0,43	469	635	0,5	2 270	0,3	3,75	285	79,3	2,5	3,57	11	
	2	1 300	18,9	34,2	0,77	0,70	469	635	0,55	2 270	0,3	3,75	285	79,3	2,5	3,57	11	
<b>32</b>	1	1 700	36,9	79,6	0,58	0,28	736	995	0,7	2 510	0,6	6,18	773	280	9,1	6,92	15	
	2	1 700	36,9	79,6	0,73	0,63	721	975	0,7	2 320	0,6	6,18	773	280	9,1	6,92	15	
<b>40</b>	1	2 150	45,4	116	0,53	0,11	1 034	1 395	1	2 840	1,2	9,69	1 900	879	18,8	9,57	18	
	2	2 150	28,7	58,6	0,69	0,54	618	835	1	2 710	1,2	9,52	1 840	951	20	13,6	18	
<b>50</b>	1	2 800	109	272	0,47	0,00	1 100	1 430	1,85	3 900	2	15	4 550	2 190	76	24,4	22	
	2	2 800	56,3	125	0,64	0,43	803	1 045	1,85	3 660	2	15	4 550	2 190	68,6	24,4	22	
	3	2 800	88	222	0,72	0,61	1 000	1 300	1,85	3 600	2	15	4 550	2 190	81,1	24,4	22	
	4	2 800	56,3	125	0,77	0,70	803	1 045	1,85	3 660	2	15	4 550	2 190	68,6	24,4	22	
<b>63</b>	2	3 600	107	267	0,59	0,29	1 177	1 530	2,5	4 540	3,8	23,9	11 600	6 460	230	44,3	28	
	4	3 600	107	267	0,73	0,63	1 177	1 530	2,75	4 540	3,8	23,9	11 600	6 460	230	44,3	28	
<b>80</b>	4	4 000	187	444	0,69	0,54	1 280	1 665	4	5 410	12,5	38,1	29 400	38 900	1 290	166	36	
<b>100</b>	5	4 000	269	688	0,69	0,54	1 323	1 720	6	5 920	22,8	59,5	71 800	108 000	4 000	308	44	
<b>125</b>	5	4 000	434	1385	0,64	0,43	2 027	2 635	8,5	6 510	46,1	93,7	179 000	342 000	11 800	520	55	

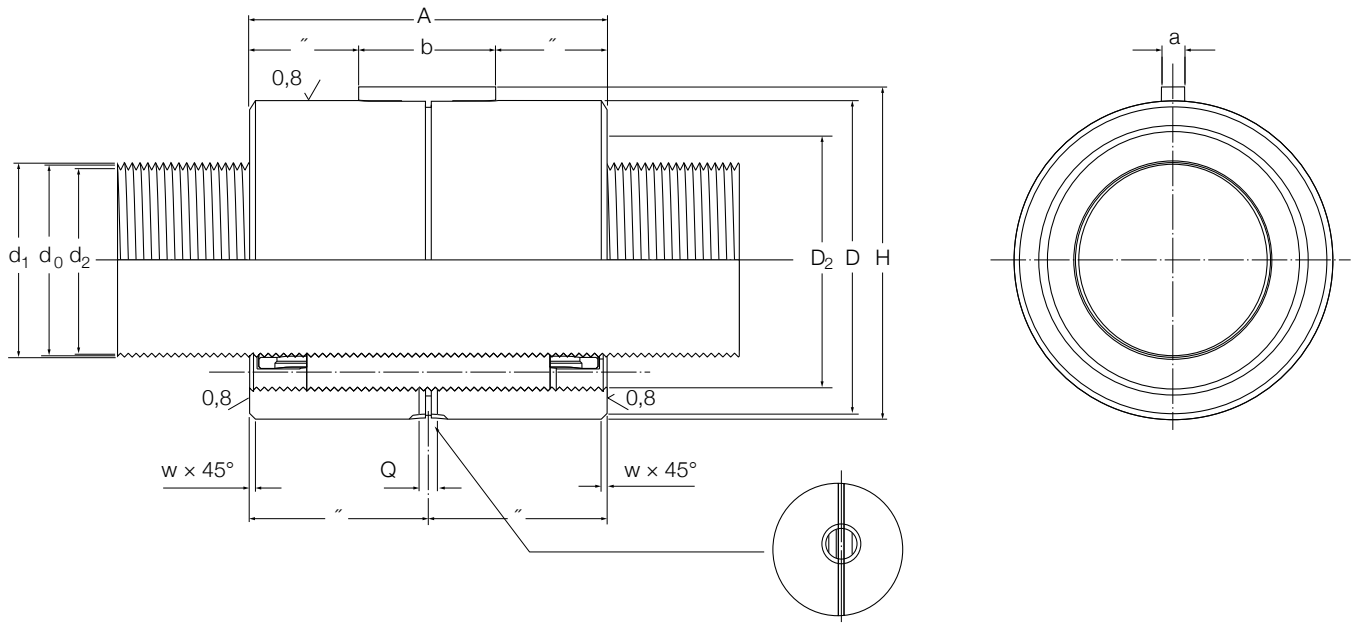

Designation	Dimensions										
	d <sub>0</sub>	d <sub>2</sub>	D	A with wiper recesses h12	A without wiper recesses h12	w	a	b	H	Q	D <sub>2</sub>
-	mm										
<b>PVU 8 x 1</b>	7,7	7,1	20	40	31	0,2	2	12	20,8	5	16,5
<b>PVU 10 x 1</b>	9,7	9,1	22	40	31	0,2	2	12	22,8	5	18,5
<b>PVU 10 x 2</b>	9,7	9,1	22	40	31	0,2	2	12	22,8	5	18,5
<b>PVU 12 x 1</b>	11,7	11,1	24	40	31	0,2	2	12	24,8	5	20,5
<b>PVU 12 x 2</b>	11,7	11,1	24	40	31	0,2	2	12	24,8	5	20,5
<b>PVU 16 x 1</b>	15,7	15,1	29	40	31	0,5	3	12	30,2	5	25
<b>PVU 16 x 2</b>	15,7	15,1	29	40	31	0,5	3	12	30,2	5	25
<b>PVU 20 x 1</b>	19,7	19,1	34	45	37	0,5	3	16	35,2	5	28,5
<b>PVU 20 x 2</b>	19,7	19,1	34	45	37	0,5	3	16	35,2	5	28,5
<b>PVU 25 x 1</b>	24,7	24,1	42	54	44	0,5	4	20	43,5	5	36
<b>PVU 25 x 2</b>	24,7	24,1	42	54	44	0,5	4	20	43,5	5	36
<b>PVU 32 x 1</b>	31,7	31,1	54	67	57	1	4	25	55,5	5	45
<b>PVU 32 x 2</b>	31,7	31,1	54	67	57	1	4	25	55,5	5	45
<b>PVU 40 x 1</b>	39,7	39,1	68	75	63	1	5	32	70	5	55
<b>PVU 40 x 2</b>	39,3	38,2	68	84	72	1	5	32	70	5	57
<b>PVU 50 x 1</b>	49,7	49,1	82	101	85	1	6	32	84,5	8	70
<b>PVU 50 x 2</b>	49,3	48,7	82	101	85	1	6	32	84,5	8	70
<b>PVU 50 x 3</b>	49,5	48,6	82	108	92	1,5	6	35	84,5	8	70
<b>PVU 50 x 4</b>	49,3	48,2	82	101	85	1	6	32	84,5	8	70
<b>PVU 63 x 2</b>	62,3	61,2	103	120	104	1	6	40	105,5	8	94
<b>PVU 63 x 4</b>	62,3	61,2	103	120	104	1	6	40	105,5	8	94
<b>PVU 80 x 4</b>	78,6	76,4	141	197	175	1,5	8	63	144	10	120
<b>PVU 100 x 5</b>	98,3	95,5	175	237	205	2	10	80	178	10	150
<b>PVU 125 x 5</b>	123,3	120,5	220	282	250	3	12	100	223	12	185

## PVK preloaded recirculating roller screws with flanged nut

d 8 – 125 mm

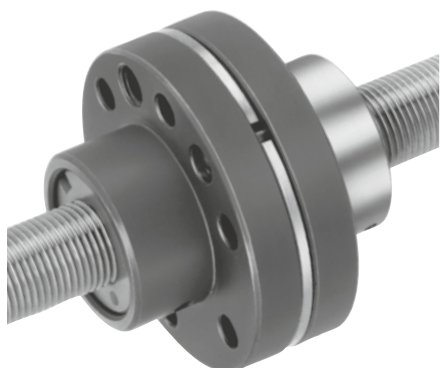

Standard PVK



Grooved rollers



Components assembly

Dimensions and technical characteristics																		
d <sub>1</sub>	P <sub>h</sub>	L <sub>tp</sub>	C <sub>a</sub>	C <sub>0a</sub>	η	η'	R <sub>ng</sub>	R <sub>nr</sub>	T <sub>pr</sub>	F <sub>pr</sub>	m <sub>n</sub>	m <sub>s</sub>	I <sub>s</sub>	I <sub>nn</sub>	I <sub>ns</sub>	Z <sub>n</sub>	Z <sub>s</sub>	
			kN		-		N/μm		Nm		N		kg		kg/m		kgmm <sup>2</sup> /m	
																	cm <sup>3</sup>	
																	cm <sup>3</sup> /m	
<b>8</b>	1	400	4,88	5,51	0,83	0,79	190	255	0,05	770	0,2	0,36	2,6	47,9	0,1	0,72	4	
<b>10</b>	1	500	5,14	5,7	0,80	0,75	185	250	0,07	820	0,2	0,57	6,7	47	0,1	0,95	5	
	2	500	5,14	5,7	0,87	0,85	185	250	0,07	820	0,2	0,57	6,7	47	0,1	0,95	5	
<b>12</b>	1	600	5,96	7	0,78	0,71	215	290	0,1	940	0,2	0,84	14,2	63,5	0,1	1,08	6	
	2	600	5,96	7	0,86	0,83	215	290	0,1	940	0,2	0,84	14,2	63,5	0,1	1,08	6	
<b>16</b>	1	825	6,71	8,42	0,73	0,63	245	330	0,15	1 060	0,3	1,51	46,2	100	0,3	1,43	8	
	2	825	6,71	8,42	0,83	0,79	245	330	0,15	1 060	0,3	1,51	46,2	100	0,3	1,43	8	
<b>20</b>	1	1 050	10,6	18,3	0,69	0,54	490	660	0,2	1 430	0,4	2,38	115	192	0,8	1,9	9	
	2	1 050	10,6	18,3	0,80	0,75	490	660	0,3	1 430	0,4	2,38	115	192	0,8	1,9	9	
<b>25</b>	1	1 300	18,9	34,2	0,64	0,43	635	855	0,5	2 270	0,6	3,75	285	416	2,5	3,57	11	
	2	1 300	18,9	34,2	0,77	0,70	635	855	0,55	2 270	0,6	3,75	285	416	2,5	3,57	11	
<b>32</b>	1	1 700	36,9	79,6	0,58	0,28	995	1 345	0,7	2 510	1,2	6,18	773	1 110	9,1	6,92	15	
	2	1 700	36,9	79,6	0,73	0,63	975	1 315	0,7	2 320	1,2	6,18	773	1 110	9,1	6,92	15	
<b>40</b>	1	2 150	45,4	116	0,53	0,11	1 395	1 885	1	2 840	2,1	9,69	1 900	3 120	18,8	9,57	18	
	2	2 150	28,7	58,6	0,69	0,54	835	1 125	1	2 710	2,2	9,52	1 840	3 200	20	13,6	18	
<b>50</b>	1	2 800	109	272	0,47	0,00	1 430	1 930	1,85	3 900	3,7	15	4 550	8 190	76	24,4	22	
	2	2 800	56,3	125	0,64	0,43	1 045	1 410	1,85	3 660	3,7	15	4 550	8 190	68,6	24,4	22	
	3	2 800	88	222	0,72	0,61	1 300	1 755	1,85	3 600	3,7	15	4 550	8 050	81,1	24,4	22	
	4	2 800	56,3	125	0,77	0,70	1 045	1 410	1,85	3 660	3,7	15	4 550	8 190	68,6	24,4	22	
<b>63</b>	2	3 600	107	267	0,59	0,29	1 530	2 065	2,5	4 540	6,4	23,9	11 600	20 100	230	44,3	28	
	4	3 600	107	267	0,73	0,63	1 530	2 065	2,25	4 540	6,4	23,9	11 600	20 100	230	44,3	28	
<b>80</b>	4	4 000	187	444	0,69	0,54	1 665	2 250	4	5 410	17,8	38,1	29 400	92 600	1 290	166	36	
<b>100</b>	5	4 000	269	688	0,69	0,54	1 720	2 320	6	5 920	33,1	59,5	71 800	256 000	4 000	308	44	
<b>125</b>	5	4 000	434	1 385	0,64	0,43	2 635	3 555	8,5	6 510	62,3	93,7	179 000	733 000	11 800	520	55	

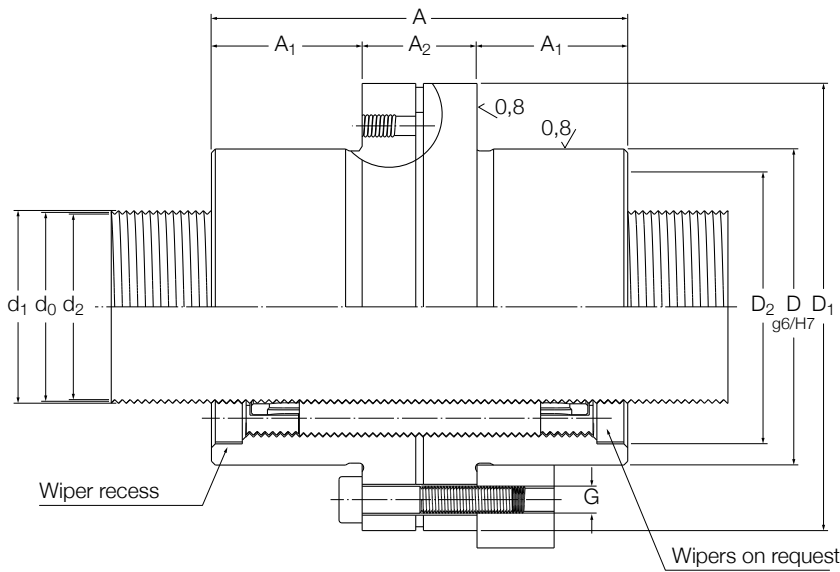

PVK:  $d_1$  8 – 63 mm

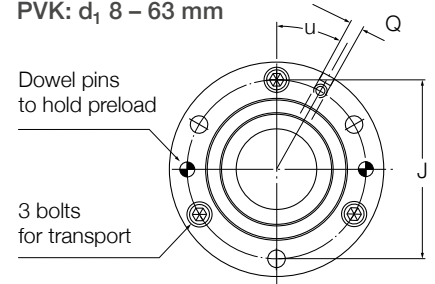

PVK:  $d_1$  80 – 125 mm

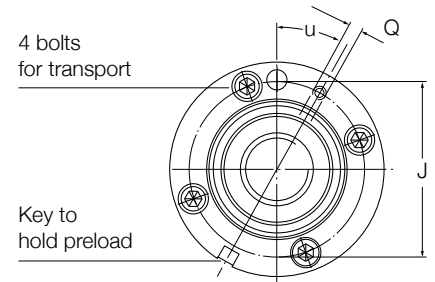

Designation	Dimensions		D g6/H7	A with wiper recesses h12	A <sub>1</sub> h12	A <sub>2</sub>	D <sub>1</sub> js12	J	G	Q	D <sub>2</sub>	u
	d <sub>0</sub>	d <sub>2</sub>										
-	mm											°
PVK 8 x 1	7,7	7,1	22	40	12	16	43	33	6 x M4	M6	16,5	30
PVK 10 x 1	9,7	9,1	22	40	12	16	43	33	6 x M4	M6	18,5	30
PVK 10 x 2	9,7	9,1	22	40	12	16	43	33	6 x M4	M6	18,5	30
PVK 12 x 1	11,7	11,1	25	40	12	16	46	36	6 x M4	M6	20,5	30
PVK 12 x 2	11,7	11,1	25	40	12	16	46	36	6 x M4	M6	20,5	30
PVK 16 x 1	15,7	15,1	30	40	12	16	51	41	6 x M4	M6	25	30
PVK 16 x 2	15,7	15,1	30	40	12	16	51	41	6 x M4	M6	25	30
PVK 20 x 1	19,7	19,1	35	45	13,5	18	58	46	6 x M5	M6	28,5	30
PVK 20 x 2	19,7	19,1	35	45	13,5	18	58	46	6 x M5	M6	28,5	30
PVK 25 x 1	24,7	24,1	45	54	18	18	68	56	6 x M5	M6	36	30
PVK 25 x 2	24,7	24,1	45	54	18	18	68	56	6 x M5	M6	36	30
PVK 32 x 1	31,7	31,1	56	67	23,5	20	84	70	6 x M6	M6	45	30
PVK 32 x 2	31,7	31,1	56	67	23,5	20	84	70	6 x M6	M6	45	30
PVK 40 x 1	39,7	39,1	68	75	24	27	102	85	6 x M8	M6	55	30
PVK 40 x 2	39,3	38,2	68	84	28,5	27	102	85	6 x M8	M6	57	30
PVK 50 x 1	49,7	49,1	82	101	34	33	124	102	6 x M10	M6	70	30
PVK 50 x 2	49,3	48,7	82	101	34	33	124	102	6 x M10	M6	70	30
PVK 50 x 3	49,5	48,6	82	108	37,5	33	124	102	6 x M10	M6	70	30
PVK 50 x 4	49,3	48,2	82	101	34	33	124	102	6 x M10	M6	70	30
PVK 63 x 2	62,3	61,2	105	120	43,5	33	150	127	6 x M12	M8 x 1	94	30
PVK 63 x 4	62,3	61,2	105	120	43,5	33	150	127	6 x M12	M8 x 1	94	30
PVK 80 x 4	78,6	76,4	140	197	76	45	200	170	8 x M16	M8 x 1	120	22,5
PVK 100 x 5	98,3	95,5	180	237	93,5	50	240	210	12 x M16	M8 x 1	150	15
PVK 125 x 5	123,3	120,5	220	282	113,5	55	310	270	12 x M18	M8 x 1	185	15



# Support bearings FLRBU

## Concept

To assist in the design and assembly process, Ewellix has developed a standard assortment of support bearings which consists of a housing, a bearing arrangement and seals. The bearings are adjusted at the factory to improve stiffness and running accuracy. Support bearings are filled with grease at the Ewellix factory and are easy to install. Standard support bearings are specifically designed for roller screws with nominal diameters from 8 mm to 80 mm (planetary roller screws) and from 8 mm to 125 mm (recirculating roller screws). These support bearings can easily be mounted on the screw shaft ends, following Ewellix recommendations for standard machined ends.

For larger roller screws, a preselection of spherical roller thrust bearings is also available.

## FLRBU sizes 1 to 9 with angular contact ball bearings

The standard assortment of support bearings consist of a steel housing and two to six angular contact ball bearings. Support bearing size FLRBU9 is available with a total of four or six bearings (↳ [pages 104 to 110](#)).

To attain the nominal life of the support bearings, the maximum static or dynamic operating load should not exceed 80% of the  $C_a$  value of the support bearing. This recommendation considers the load carrying capacity of the bearings, the strength of the support bearing housing and the KMT locknut.

## Larger support bearing sizes with spherical roller thrust bearings

For extremely high load applications, Ewellix has preselected sizes of spherical roller thrust bearings for assembly with back-to-back arrangement into larger support bearings. These support bearings are typically used in applications where there are extremely heavy axial loads in one direction and lighter loads in the other direction, e.g. presses. As a result, these assemblies typically have two different size bearings, supporting the application axial loads in each direction, and requiring the support bearing to be oriented correctly (↳ [fig. 24, page 111](#)).

For additional information about optimizing the selection of each spherical roller thrust bearing, please contact your local Ewellix representative.

## Support bearings description

Design features	User benefits
Precision machined steel housing	Complete support bearing solution ready to use, simplified application design, easy ordering process Eliminates most technical risks associated with bearing and seal assemblies
Preloaded Ewellix Explorer angular contact ball bearings, 72 or 73 series, arranged back-to-back (1 + 1 for FLRBU1 and FLRBU2, 2 + 2 for FLRBU3 to FLRBU9 and 3 + 3 for FLRBU9)	Bearing solutions offering high speed capability and low friction torque Bearings are arranged back-to-back and preloaded to increase stiffness and improve running accuracy
Two garter seals	Greased for life
Precision KMT locknut as standard	KMT locknuts are part of the standard Ewellix product assortment, and can be ordered separately
Standard screw shaft end machining defined for extremely heavy axial loads	Quick connection to shaft ends
Different bearing arrangements are available on request, should the applications present unique load conditions with the axial loads predominantly acting in one direction (1 + 3 or 3 + 1)	Bearing load carrying capacity matched to the roller screw load carrying capacity and application conditions
Ewellix spherical roller thrust bearings for extremely heavy axial loads	Support bearing dimensioning and load carrying capacity matched to the roller screw characteristics

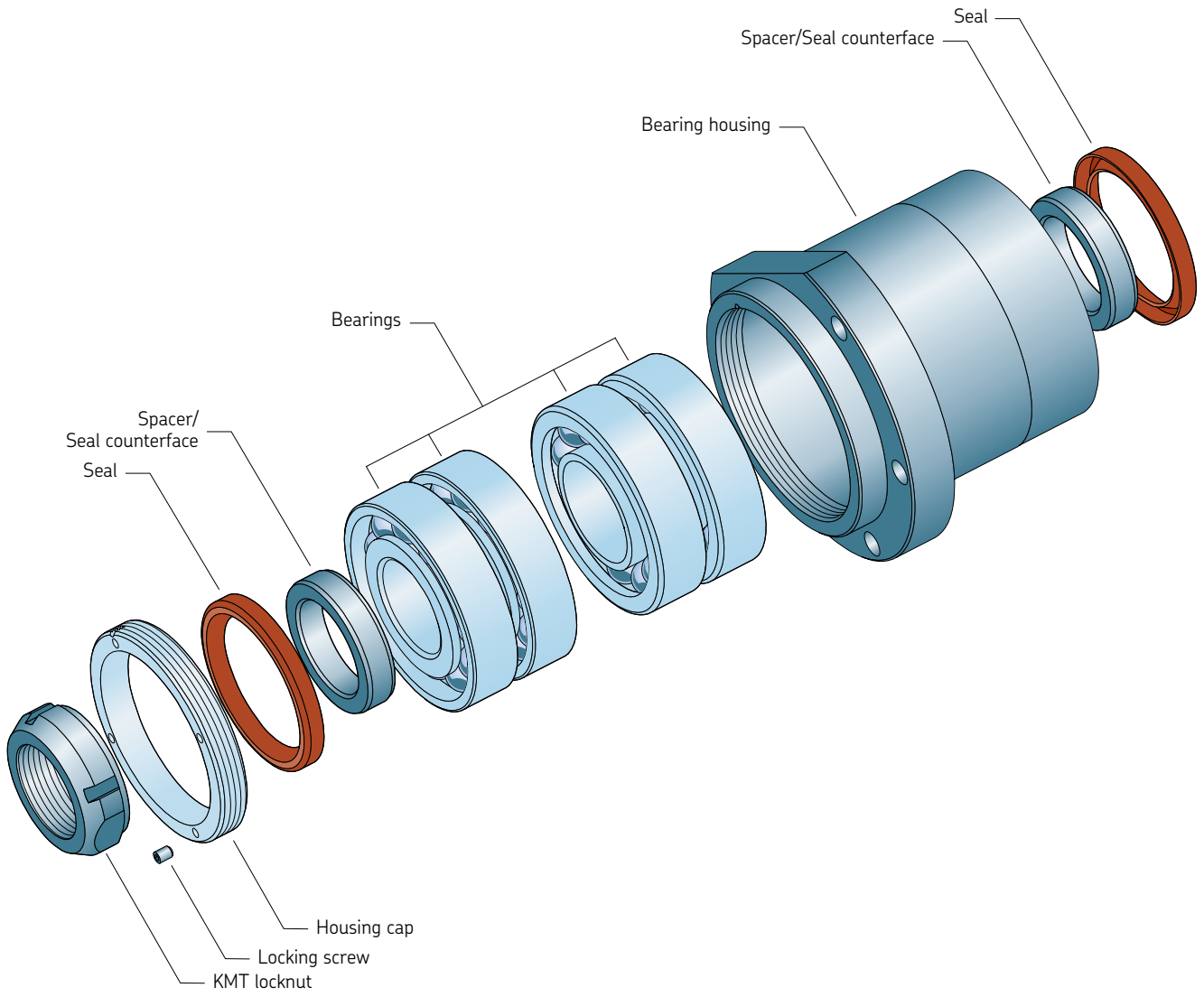

FLRBU support bearings with angular contact ball bearings

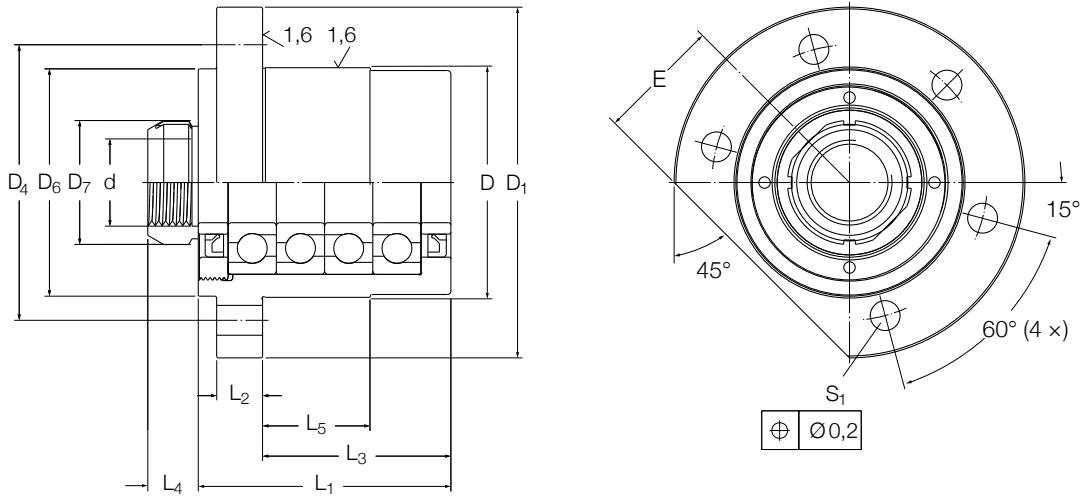

Support bearing designation	Support bearings bore diameter d mm	Support bearing carrying capacity		Standard bearing arrangement	Bearing designation	Maximum preload torque Nm	Axial stiffness of the bearing stack <sup>1)2)</sup> N/µm	Weight kg	High precision KMT locknut				
		Dynamic C <sub>a</sub> kN	Static C <sub>0a</sub>						Designation	Hook spanner	Tightening torque Nm	Grub screw size	Grub screw tightening torque Nm
FLRBU1	12	13,3	14,7	1 + 1	7 201	0,1	150	0,69	KMT 1	HN 3	15	M5	4,5
FLRBU2	17	27,9	31,9	1 + 1	7 303	0,25	190	1,93	KMT 3	HN 4	22	M6	8
FLRBU3	20	40,1	63,8	2 + 2	7 204	0,25	475	1,61	KMT 4	HN 5	27	M6	8
FLRBU4	25	74,2	119	2 + 2	7 305	1,1	600	3,30	KMT 5	HN 5	38	M6	8
FLRBU5	35	109	188	2 + 2	7 307	1,1	785	5,85	KMT 7	HN 7	65	M6	8
FLRBU6	50	208	392	2 + 2	7 310	1,5	1 100	11,1	KMT 10	HN 10	110	M8	18
FLRBU7	65	305	615	2 + 2	7 313	2	1 400	25,1	KMT 13	HN 14	200	M8	18
FLRBU8	90	473	1 123	2 + 2	7 318	2,3	1 800	53,1	KMT 18	HN 18	300	M10	35
FLRBU9 (2 + 2)	100	615	1 600	2 + 2	7 320	3	2 100	73,1	KMT 20	HN 20	400	M10	35
FLRBU9 (3 + 3)	100	817	2 400	3 + 3	7 320	3,5	2 600	96,1	KMT 20	HN 20	400	M10	35

Support bearing designation	Support bearings bore diameter d mm	Dimensions											S <sub>1</sub> H13	Fixing screws
		D <sub>1</sub>	D <sub>6</sub>	D h7	D <sub>4</sub>	D <sub>7</sub>	E	L <sub>1</sub>	L <sub>2</sub>	L <sub>3</sub>	L <sub>4</sub>	L <sub>5</sub>		
FLRBU1	12	76	50	47	63	30	27	42	10	25	14	12	(5x) 6,6	M6 x 25
FLRBU2	17	90	62	60	76	37	32	46	10	32	18	18	(5x) 6,6	M6 x 25
FLRBU3	20	90	59	60	74	40	32	77	13	60	18	30	(5x) 9	M8 x 25
FLRBU4	25	120	80	80	100	44	44	89	16	68	20	36	(5x) 11	M10 x 30
FLRBU5	35	140	99	100	120	54	54	110	20	82	22	47	(5x) 13	M12 x 40
FLRBU6	50	171	130	130	152	75	67	140	25	98,5	25	58,5	(5x) 13	M12 x 40
FLRBU7	65	225	170	170	198	95	87	180	30	133,5	28	53,5	(5x) 17,5	M16 x 55
FLRBU8	90	285	219	220	252	125	115	235	35	179	32	99	(5x) 22	M20 x 65
FLRBU9 (2 + 2)	100	322	249	250	285	135	130	253	36	195	32	115	(9x) 243	M22 x 70
FLRBU9 (3 + 3)	100	322	249	250	285	135	130	347	36	289	32	115	(9x) 243	M22 x 70

**Preferred range:** support bearing available in stock, for 2+2, 1+3 and 3+1 variants  
<sup>1)</sup> Axial stiffness of the housing and bearings assembly, KMT locknut and shaft stiffness not included  
<sup>2)</sup> Axial stiffness is calculated under F = 10% of C<sub>a</sub>  
<sup>3)</sup> For the layout of mounting holes and detailed information, please contact Ewellix.

## Standard machined ends

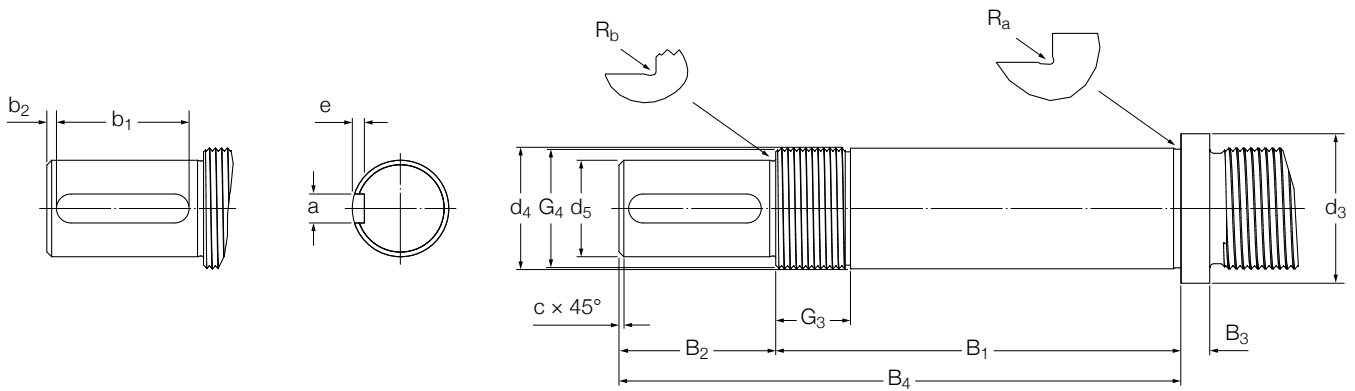

Support bearing designation	Dimensions															
	$d_4^{1)}$ mm	$d_5$ h7	$d_3$	$B_1$ js12	$B_2$	$B_3$	$B_4$ js12	$G_4$ 6g	$G_3$	$c$	$R_a$	$R_b$	$a$ N9	$e$ + 0,1	$b_1$ + 0,5	$b_2$
-																
<b>FLRBU1</b>	<b>12</b>	10	17	58	20	5	78	M12 x 1	17	0,5	0,4	0,4	3	1,8	16	1,5
<b>FLRBU2</b>	<b>17</b>	15	23	66	30	5	96	M17 x 1	22	0,5	0,6	0,6	5	3	25	2
<b>FLRBU3</b>	<b>20</b>	17	27	97	40	7	137	M20 x 1	22	0,5	0,6	0,6	5	3	35	2
<b>FLRBU4</b>	<b>25</b>	20	34	112	45	7	157	M25 x 1,5	25	0,5	0,6	0,6	6	3,5	40	2,5
<b>FLRBU5</b>	<b>35</b>	30	45	134	55	10	189	M35 x 1,5	26	1	0,6	0,6	8	4	45	2,5
<b>FLRBU6</b>	<b>50</b>	40	62	168	65	12	233	M50 x 1,5	31	1	0,8	0,8	12	5	55	4
<b>FLRBU7</b>	<b>65</b>	60	78	210	100	18	310	M65 x 2	32	1	1,2	1	18	7	90	2,5
<b>FLRBU8</b>	<b>90</b>	85	108	270	120	25	390	M90 x 2	39	1	1,6	1,2	25	9	100	5
<b>FLRBU9 (2 + 2)</b>	<b>100</b>	95	120	288	140	25	428	M100 x 2	39	1	1,6	1,2	25	9	125	7
<b>FLRBU9 (3 + 3)</b>	<b>100</b>	95	120	382	140	25	522	M100 x 2	39	1	1,6	1,2	25	9	125	7

Standard tolerance for direct drive:  $d_4$ h6. Recommended tolerance for parallel drive:  $d_4$ k6

## Recommendations for support bearings assembly and orientation

Standard support bearing orientation: Flange oriented towards machined end of shaft

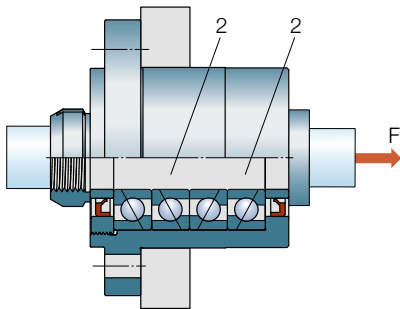

**FLRBU (1 + 1) (2 + 2) (3 + 3)**

- Assembly recommended for similar tension and compression loads on roller screw
- Customer to check flange fixing bolts with compression loads

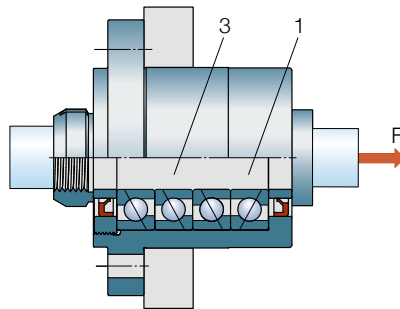

**FLRBU (3 + 1)**

- Assembly recommended for predominantly tension loads on roller screw
- Customer to check flange fixing bolts with compression loads

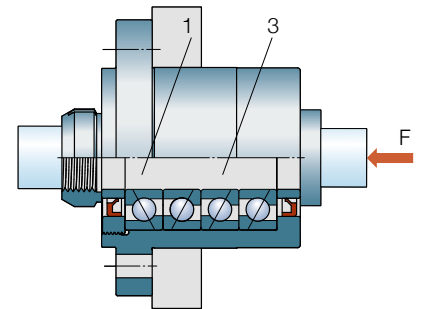

**FLRBU (1 + 3)**

- Not the ideal assembly in case of predominantly compression loads on roller screw
- Customer to check flange fixing bolts with compression loads

Non-standard support bearing orientation: Flange oriented towards thread of roller screw shaft

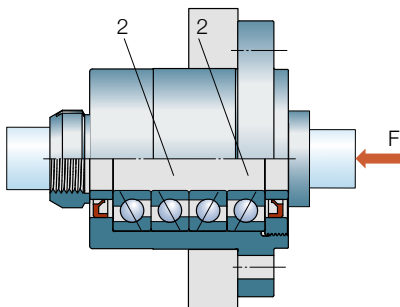

**FLRBU (1 + 1) (2 + 2) (3 + 3)**

- Assembly recommended for similar tension and compression loads on roller screw
- Customer to check flange fixing bolts with tension loads

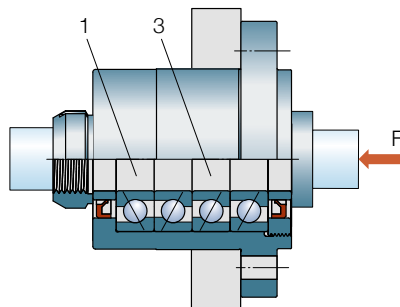

**FLRBU (3 + 1)**

- Assembly recommended for predominantly compression loads on roller screw
- Customer to check flange fixing bolts with tension loads

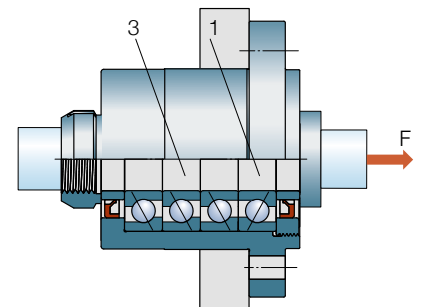

**FLRBU (1 + 3)**

- Not the ideal assembly in case of predominantly tension loads on roller screw
- Customer to check flange fixing bolts with tension loads

Support bearing bore diameter	Load ratings for the 3 bearings carrying the main application loads		Load ratings for the opposite single bearing		Support bearing designation
	Support bearing carrying capacity		Support bearing carrying capacity		
d mm	Dvynamic C kN	Static C <sub>0</sub>	Dvynamic C kN	Static C <sub>0</sub>	-
20	53,3	95,7	24,7	31,9	<b>FLRBU3</b>
25	98,6	179	45,7	59,6	<b>FLRBU4</b>
35	145	283	67,3	94,2	<b>FLRBU5</b>
50	277	589	128	196	<b>FLRBU6</b>
65	405	923	188	308	<b>FLRBU7</b>
90	628	1 685	291	561	<b>FLRBU8</b>
100	817	2 400	378	800	<b>FLRBU9</b> (version with 4 bearings)

■ Preferred range

## Support bearings recommended for standard planetary roller screws

(standard number of rollers)

Planetary roller screws SR/BR, PR, HR: Recommended size of FLRBU support bearings <sup>1)</sup>																	
Nominal diameter	Nut type	Lead [mm]															
		2	4	5	6	8	9	10	12	15	18	20	24	25	30	35	36
d <sub>0</sub> mm	-	FLRBU size															
8	SR/BR	1	1														
8	PR	1	1														
12	SR/BR	2		2													
12	PR	1		1													
15	SR/BR	2		2		2											
15	PR	1		1		1											
18	SR/BR	3		3		3											
18	PR	2		2		2											
21	SR/BR	4		4	4	4		4									
21	PR	2		2	2	2		2		3							
24	SR/BR				3				4								
24	PR				2				2								
25	SR/BR		4		4		4		4		4						
25	PR		3		3		3		3		3						
30	SR/BR		5	5	5		5		5		5						
30	PR		4	4	4		4		4		4						
36	SR/BR			5		5		5		5		5					
36	PR			4		4		4		4		4					
39	SR/BR		6				6		6		6		6				
39	PR		5				5		5		5		5				
44	SR/BR			6			6		6		6		6		6		
44	PR			4			4		4		5		5		5		
48	SR/BR		6		6		6		7		7		7		7		
48	PR		5		5		6		6		6		6		6		
56	SR/BR							6			7					7	
56	PR							5			6					6	
60	SR/BR							8		8		8					
60	PR							6		6		6					
60	HR								8		8		8		8		
64	SR/BR							7		7		7		7		7	
64	PR							6		6		6		6		6	
75	SR								9		9		9				
75	HR								(2 + 2)		(2 + 2)		(2 + 2)				
										9		9		9		9	
										(3 + 3)		(3 + 3)		(3 + 3)		(3 + 3)	
80	SR								8		8		8				8

SR (C, F or P): Planetary roller screw with axial play; BR (C, F or P): Planetary roller screw without backlash  
 PR (U or K): Planetary roller screw with preloaded split nut; HR (C, F or P): Ultra Power planetary roller screw

<sup>1)</sup> Some SR/BR and PR planetary roller screw sizes (normal diameter x lead) are available with the maximum number of rollers only.  
 In such case, the recommended FLRBU support bearing size is suitable for these configurations

## Support bearings recommended for recirculating roller screws

Recirculating roller screws SV/BV, PV: Recommended size of FLRBU support bearings

Nominal diameter	Nut type	Lead [mm]				
		1	2	3	4	5
d <sub>1</sub> mm	–	FLRBU size				
<b>8</b>	SV/BV	1				
<b>8</b>	PV	1				
<b>10</b>	SV/BV	1	1			
<b>10</b>	PV	1	1			
<b>12</b>	SV/BV	1	1			
<b>12</b>	PV	1	1			
<b>16</b>	SV/BV	1	1			
<b>16</b>	PV	1	1			
<b>20</b>	SV/BV	2	2			
<b>20</b>	PV	1	1			
<b>25</b>	SV/BV	3	3			
<b>25</b>	PV	2	2			
<b>32</b>	SV/BV	4	4			
<b>32</b>	PV	3	3			
<b>40</b>	SV/BV	5	4			
<b>40</b>	PV	4	3			
<b>50</b>	SV/BV	6	5	6	5	
<b>50</b>	PV	5	4	5	4	
<b>63</b>	SV/BV		6		6	
<b>63</b>	PV		6		6	
<b>80</b>	SV/BV				7	
<b>80</b>	PV				6	
<b>100</b>	SV/BV					8
<b>100</b>	PV					7
<b>125</b>	SV/BV					9 (3 + 3)
<b>125</b>	PV					8

SV (C or F): Recirculating roller screw with axial play  
 BV (C or F): Recirculating roller screw without backlash  
 PV (U or K): Recirculating roller screw with preloaded split nut

## Preselection of spherical roller thrust bearings

Fig. 23

Symmetrical bearing arrangement

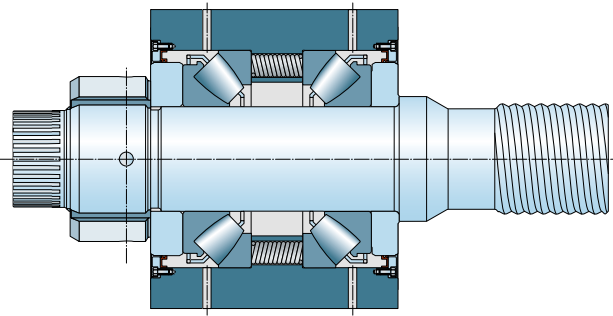
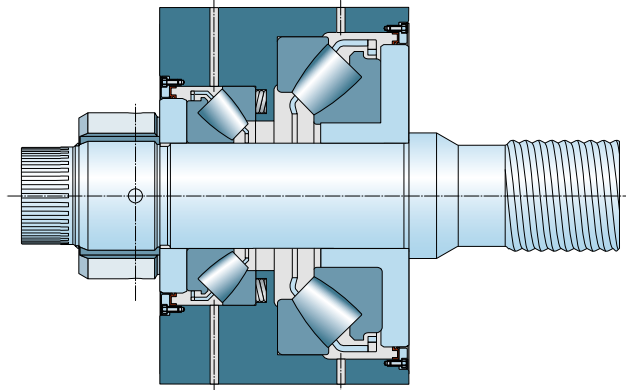

Fig. 24

Non-symmetrical bearing arrangement



For applications where FLRBU9 support bearings cannot accommodate existing loads, Ewellix can supply FLRBUs containing spherical roller thrust bearings. These larger support bearings complement the assortment of large roller screws and Ultra Power roller screws.

Spherical roller thrust bearing arrangements can be either symmetrical or non-symmetrical. Non-symmetrical arrangements are typically used when loads are heavier on one direction than the other.

Because these support bearings are used on large machinery, Ewellix designs the housing and bearing arrangement on a case by case basis.

For additional information about these support bearings, please contact your local Ewellix representative.

Preselection of spherical roller thrust bearings (see recommendation in Ewellix catalogue Rolling bearings)

Ultra Power roller screws		Recommended size of spherical roller thrust bearings						
$d_0$ mm	$P_h$	Bore diameter $d$ mm	Outer diameter $D$	Bearing mean diameter $d_m$	Height $H$	Basic load rating Dynamic $C$ kN	Static $C_0$	Bearing designation <sup>1)</sup>
<b>87</b>	15 to 30	110	230	170	73	1 180	3 000	<b>29422 E</b>
<b>99</b>	15 to 35	130	270	200	85	1 560	4 050	<b>29426 E</b>
<b>112,5</b>	15 to 35	140	280	210	85	1 630	4 300	<b>29428 E</b>
<b>120</b>	15 to 40	150	300	225	90	1 860	5 100	<b>29430 E</b>
<b>135</b>	15 to 50	160	320	240	95	2 080	5 600	<b>29432 E</b>
<b>150</b>	15 to 50	170	340	255	103	2 360	6 550	<b>29434 E</b>
<b>180</b>	15 to 50	200	400	300	122	3 200	9 000	<b>29440 E</b>
<b>210</b>	20 to 50	240	440	340	122	3 400	10 200	<b>29448 E</b>
<b>240</b>	20 to 50	260	480	370	132	4 050	12 900	<b>29452 E</b>

<sup>1)</sup> Ewellix Explorer bearing

For selection and dimensioning of spherical roller thrust bearings, for recommendations regarding minimum load, calculation of equivalent dynamic/static bearing loads, lubrication, design of bearing arrangements and mounting, please refer to Ewellix catalogue Rolling bearings.

In particular, the following calculation assumptions must be used:

- The maximum axial load must not exceed a quarter of the bearing static load rating

$$s_0 = C_0/F$$

$$s_0 \geq 4$$

With

$C_0$  = bearing static load carrying capacity [kN]

$F$  = maximum static or dynamic axial bearing carrying this load [kN]

- The permissible rotational speed of the bearing depends on the ratio of dynamic load rating to bearing equivalent mean load  $F_m$

$$\text{If } C/F_m \leq 4$$

$$\hookrightarrow \text{Maximum } n \text{ } d_m = 60\,000$$

$$\text{With } C/F_m = 8$$

$$\hookrightarrow \text{Maximum } n \text{ } d_m = 120\,000$$

$$\text{If } C/F_m \geq 15$$

$$\hookrightarrow \text{Maximum } n \text{ } d_m = 200\,000$$

With

$C$  = bearing dynamic load carrying capacity [kN] according to the Ewellix catalogue Rolling bearings

$F_m$  = equivalent dynamic load applied to the roller screw and to the spherical roller thrust bearing carrying this axial load [kN]

$n$  = screw shaft rotational speed [r/min]

$d_m$  = bearing mean diameter [mm]

# Ordering key

## Complete roller screw assembly

	SRF	30 x 5R	425/590	G5	L	Z	WPR
<b>Nut type</b>							
SRC	Planetary roller screw, axial play, cylindrical nut						
BRC	Planetary roller screw, without backlash, cylindrical nut						
SRF	Planetary roller screw, axial play, centered flange						
BRF	Planetary roller screw, without backlash, centered flange						
SRP	Planetary roller screw, axial play, off-centered flange						
BRP	Planetary roller screw, without backlash, off-centered flange						
PRU	Planetary roller screw, preload with split nut, cylindrical nut						
PRK	Planetary roller screw, preload with split nut, centered flange						
HRC	Ultra Power planetary roller screw, cylindrical nut						
HRF	Ultra Power planetary roller screw, centered flange						
HRP	Ultra Power planetary roller screw, off-centered flange						
ISR	Inverted planetary roller screw, axial play						
IBR	Inverted planetary roller screw, without backlash						
SRR	Planetary roller screw, rotating nut, axial play						
BRR	Planetary roller screw, rotating nut, without backlash						
SVC	Recirculating roller screw, axial play, cylindrical nut						
BVC	Recirculating roller screw, without backlash, cylindrical nut						
SVF	Recirculating roller screw, axial play, centered flange						
BVF	Recirculating roller screw, without backlash, centered flange						
PVU	Recirculating roller screw, preload with split nut, cylindrical nut						
PVK	Recirculating roller screw, preload with split nut, off-centered flange						
<b>Nominal diameter x lead [mm]</b>							
<b>Hand</b>							
R	Right						
L	Left (on request)						
<b>Threaded length/Total length [mm]</b>							
<b>Lead precision</b>							
G5	Standard lead precision						
G3	Lead precision on request						
G1	Lead precision on request						
<b>Flanged nut orientation</b>							
S	Nut ground outer diameter D (g6) oriented towards shorter machined end of shaft						
L	Nut ground outer diameter D (g6) oriented towards longer machined end of shaft						
-	In case of identical machined ends, and for cylindrical nuts						
<b>Shaft machined end</b>							
Z	According to customer drawing						
<b>Wipers</b>							
WPR	With wipers						
NOWPR	Without wipers						
NORCS	Nut design without wipers recesses (for special SR nut types only)						
<b>Example</b>	SRC 25 x 5R 425/590 G5 L Z WPR						

4

## Mounting instruction

Recommendations for assembly

# Recommendations for assembly

## Handling

Roller screw assemblies are precision components and should be handled with care to avoid damaging shocks, contamination or corrosion. After cleaning, avoid touching the screws with bare hands. Unprotected screws made of standard bearing steel are very sensitive to corrosion.

## Storage

Roller screw assemblies should be stored so that they are not exposed to contaminants, vibrations, shocks, humidity or other detrimental conditions.

During shipping, roller screw assemblies are wrapped in heavy gauge plastic bags, which protect them from solid or liquid contaminants. They should remain in the shipping crate and wrapped until they are used.

If they are stored out of the shipping crate, roller screw assemblies must lie on wooden, plastic or aluminum V-shaped blocks and should not be subjected to vibrations. The V-shaped supports should be positioned on the threaded section of the screw shaft, or on the machined ends. The assembly must not be supported on the shelf by the nut body (↳ **fig. 38**).

The standard rust inhibitor protects roller screws in their original sleeve for a period of 12 to 18 months. Storage temperature should range between – 10 and +50 °C. For longer storage periods, special packing such as VCI sleeve can be used. For additional information about roller screw storage, please contact your local Ewellix representative.

## Nut disassembly

If possible, do not remove the nut from the shaft, especially for preloaded assemblies. If the nut must be removed from the shaft, i.e. for shaft end machining, check the nut orientation before disassembly.

Identify the type of nut by removing one wiper.

**Fig. 41:** Planetary roller screw

**Fig. 42:** Recirculating roller screw

For a recirculating roller screw with a nominal diameter < 16 mm, the nut should never be removed from the screw without using a sleeve (risk of losing the rollers).

For the other recirculating roller screws and for all planetary roller screws, the nut can be removed without any risk. But if the nut is fitted with wipers (components usually are black or white), Ewellix recommends marking the wipers and their angular position in relation to the nut (↳ **fig. 40**) to facilitate the reassembly process.

In order to achieve the proper axial play or preload required by the application, each nut is matched to its shaft. Therefore, special attention must be paid not to mix nuts and shafts during disassembly.

Just changing the orientation of a preloaded nut onto its matched screw shaft will affect the preload torque. Again, special care is required for proper disassembly and reassembly!

With preloaded assemblies (screws types with prefix PRU, PRK, PVU and PVK), do not remove the retaining device used for transportation inside the packaging. The retaining device can be:

- Transportation bolts (usually 3 screws) for the flanged types PRK and PVK
- Retaining strap for the cylindrical types PRU and PVU (↳ **fig. 39**). When removing the retaining strap, there is a high risk of dropping the preloading spacers and the key. Therefore, this operation should be performed at the last minute when pressing the nut into its housing

Fig. 38  
Roller screw on V-shaped supports

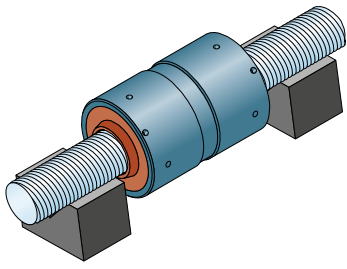

Fig. 41  
Planetary roller screw

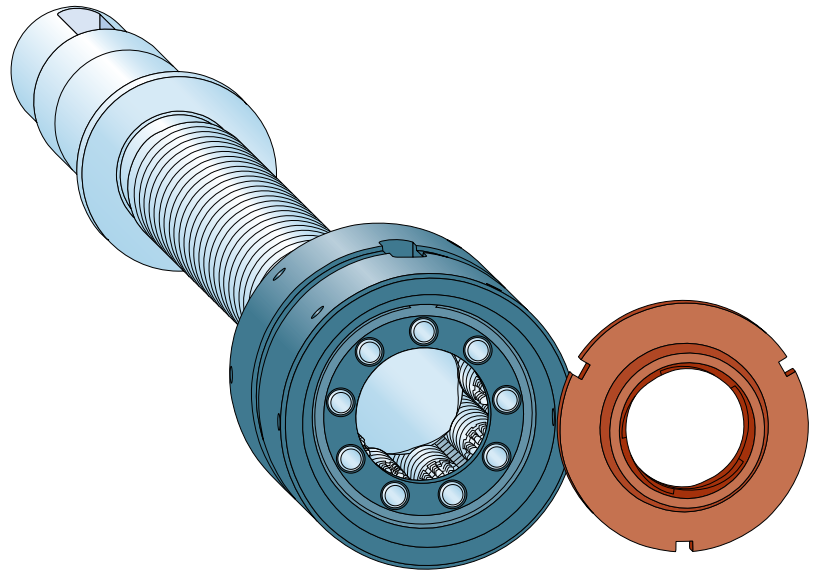

Fig. 39  
Retaining strap

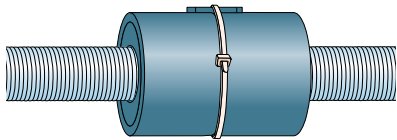

Fig. 40  
Roller screw with wiper

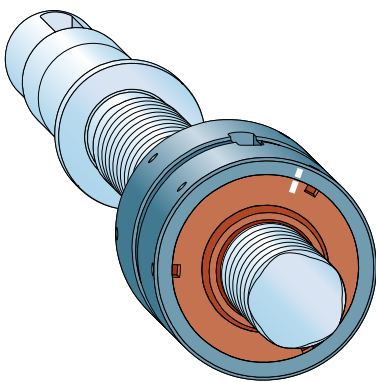
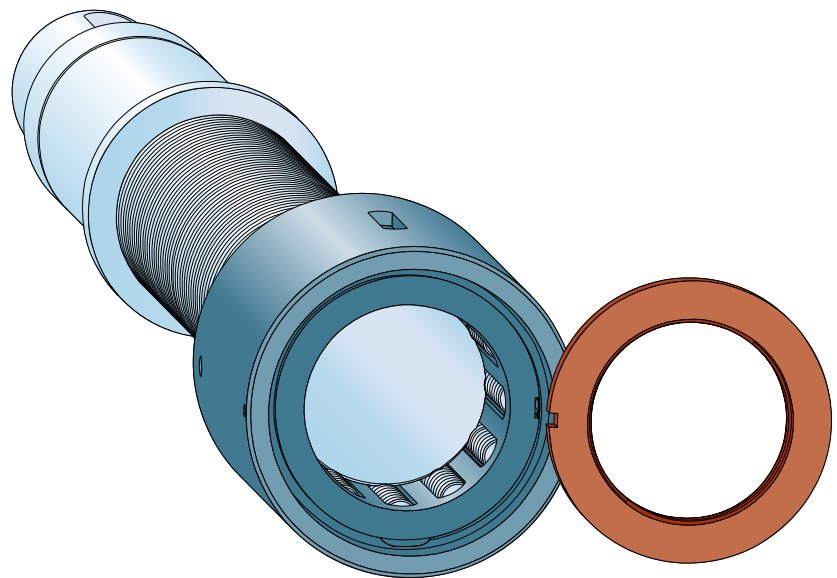

Fig. 42  
Recirculating roller screw



## Lubrication

The rust inhibitor is not a lubricant. For grease or oil lubrication, please refer to the lubrication chapter in this catalogue.

## Starting up the screw

After the assembly has been cleaned, fitted and lubricated, allow the nut to make several full strokes at low speed (< 50 r/min) and under light load (not to exceed 5% of the roller screw dynamic load carrying capacity) in order to check the proper positioning of the limit switches or reversing mechanism. Then, normal load and speed can be applied.

## Running in period

Non-preloaded roller screws will experience a running in process during the first hours of operation.

Ewellix recommends injecting half the volume of grease in the nut after running in, to renew the lubricant potentially contaminated by running in particles.

For preloaded roller screws, a running in of 20 000 revolutions is performed before delivery.

## Monitoring screw life

At the end of the screw's service life, the following conditions become observable: Fatigue flaking, increase in axial play, deterioration of running behavior, increase in driving torque and increase in operating temperature. Also, lubricant becomes noticeably contaminated. These indicators are important methods of monitoring the condition of a roller screw. Immediate replacement is recommended at the end of the service life in order to avoid any damage to the installation.

### Important:

Poor quality or lack of lubricant, abnormal stresses, misalignment and tilting, and operation outside defined specifications will increase operating temperature of the roller screw. Monitoring the operating temperature will help detect any irregularities.

## Traceability

Each roller screw shaft and nut are identified by engraving with unique manufacturing order and serial number. Each screw's individual dimensional data, lead precision, axial play, preload torque, etc. are recorded and archived by Ewellix for a period of 10 years. This period can be enlarged for special applications.

## Support bearings assembly

1. Check the direction of fitting (position of the flange) before fitting a FLRBU support bearing
2. If necessary, heat the FLRBU up to 80 °C with an Ewellix heater
3. Fit the FLRBU on the screw (check that it fits against the surface of the screw flange)
4. Prepare the KMT locknut and loosen the KMT locking screws one-quarter of a turn
5. Fit the KMT locknut:
  - Tighten to 1,5 times the tightening torque listed in the product table
  - Loosen the nut
  - Retighten the KMT locknut to the torque values listed in the product table and tighten the locking screws
6. Check the radial run-out of the machined end and mark the upper point
7. If the run-out is out of tolerance, loosen and retighten the radial locking screw which is closest to the previously marked upper point
8. Check the radial run-out again
9. Check the operation of the support bearing.

## Recommendations for bolts used with flanged nuts

Ewellix recommends using bolts with steel quality that complies with ISO class 12.9.

## Alignment

Ewellix linear guidance systems should be checked for proper alignment to avoid non-axial loading on the roller screw. If external linear guidance does not meet these requirements, we suggest mounting the roller screw nut on trunnions, or mounting the screw shaft on self-aligning bearings.

For assembly, Ewellix recommends the following procedure which applies to an assembly with a rotating shaft screw and stationary nut.

The linear guides must be correctly mounted according to recommendations for the selected guidance system.

Fig. 43

Support bearing assembly

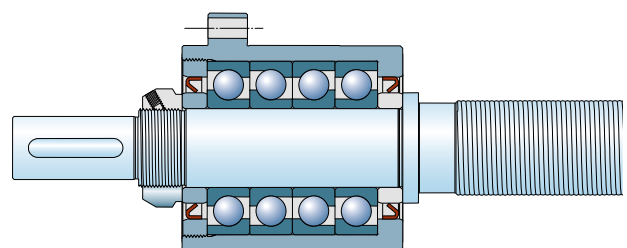

**1. Align the screw shaft with the linear guides**

Align the support bearing housings with the guides to obtain parallelism of the screw shaft with respect to the linear guides. The inclination of the support bearing axis versus the linear guide, in two perpendicular planes, must be less than  $1/2\ 000$  rad ( $0,03^\circ$ ), the ideal target being  $1/5\ 000$  rad ( $0,011^\circ$ ) (→ fig. 44).

Align the screw shaft with the linear guides

Fig. 44

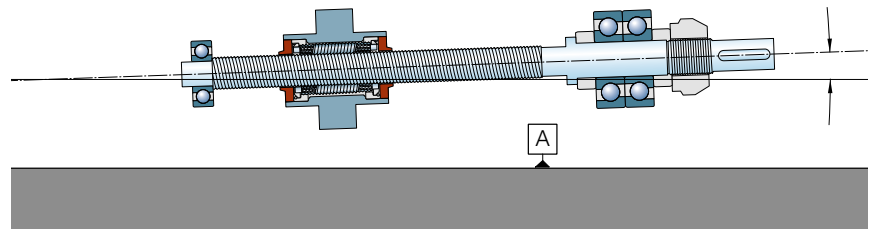

**2. Align the nut housing with the linear guides**

Align the roller screw nut housing with the axis of the linear guides to obtain parallelism of the nut axis with the linear guides. The inclination must be less than  $1/2\ 000$  ( $0,03^\circ$ ), the ideal target being  $1/5\ 000$  ( $0,011^\circ$ ). These tolerances must be maintained under load (→ fig. 45).

Align the nut housing with the linear guides

Fig. 45

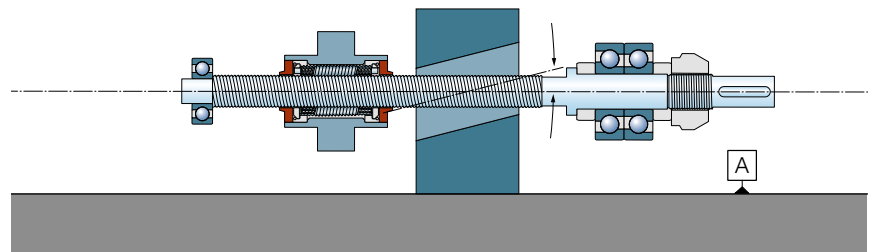

**3. Check the concentricity of the nut housing with the support bearings**

Ewellix recommends checking that the nut housing is not off-centered versus the support bearings of the shaft. Otherwise, the excessive off-centered position of the nut housing would result in unacceptable radial loading on the roller screw. The radial eccentricity in two perpendicular planes must not exceed 0,02 mm between the nut housing bore diameter and the support bearings axis (→ fig. 46).

Check the concentricity of the nut housing with the support bearings

Fig. 46

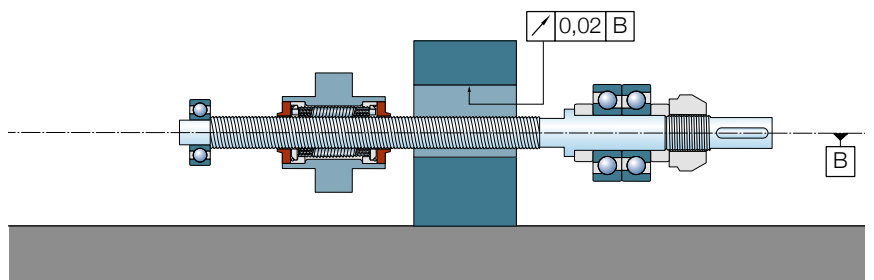

**4. Check the axial run-out of the nut housing face versus the screw shaft axis (flanged nuts)**

Ewellix recommends checking that the nut housing presents the appropriate perpendicularity to the roller screw axis to avoid the tilting of the screw nut and to avoid uneven loading along the rollers. The axial run-out of the housing face must be (→ fig. 47):

Check the axial run-out of the nut housing face versus the screw shaft axis

Fig. 47

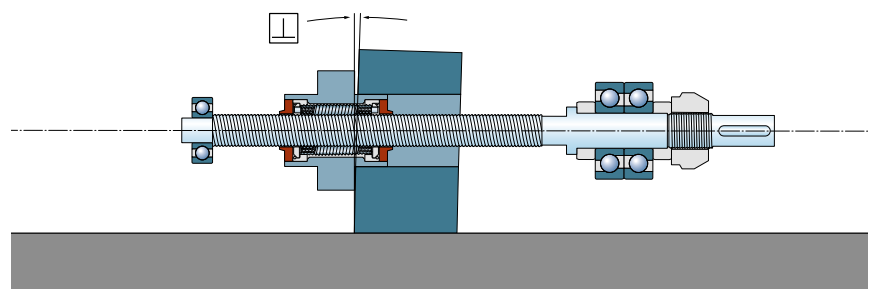

- Lower than 0,015 mm for screws with  $d_0 \leq 15$  mm
- Lower than 0,02 mm for screws with  $15 < d_0 \leq 39$  mm
- Lower than 0,04 mm for screws with  $d_0 > 39$  mm.

# Lubrication

## Lubrication for roller screws

The primary objectives of lubrication are:

- To prevent metal-to-metal contact between the rolling surfaces, and to minimize metal fatigue
- To protect against corrosion
- To minimize wear
- To maximize the roller screw service life
- To achieve performance requirements for given operational conditions (temperature, humidity, vacuum environment, corrosive environment, etc.)

In standard delivery conditions, roller screws are not lubricated. However, they can be lubricated on request. Please contact your local Ewellix representative. For roller screws with standard delivery conditions, customers must provide proper lubrication prior to operation.

**Important:**

Before shipping, roller screws are coated with a rust inhibitor. The inhibitor is not a lubricant. Depending on the lubricant selected for the application, it may be necessary to remove the rust inhibitor before applying the lubricant in order to eliminate any risk of incompatibility. To remove the film, Ewellix recommends the following procedure:

- Wash the roller screw assembly with a solvent
- Allow the solvent to penetrate the nut assembly
- Let the solvent drain completely from the roller screw assembly

The rust inhibitor Ewellix applies to its roller screws is not compatible with the following lubricants:

- Polyglycol base oil
- Ester base oil
- Silicone base oil
- Aluminum complex soap

If any of the above lubricants are used, please follow the procedure above to remove the rust inhibitor prior to lubrication.

There are three main types of lubricants, grease, oil and dry lubricant. In the majority of applications, grease or oil lubrication will be selected. Due to similar tribological conditions, most greases or oils recommended for gears and bearings are also suitable for roller screw lubrication (↳ table 5).

Table 5

Different lubricant pros and cons

Type of lubricant	User benefits	Constraints
Grease	Most practical and most usual lubrication solution for roller screws	Requires relubrication schedule
Oil	Higher lubrication performance for roller screws Circulating oil helps to clean the roller screw mechanism and stabilize the operating temperature	Requires more complex equipment installation Special care required for equipment cleanliness and tightness
Dry coating	Lubrication solution for specific applications or environments where liquid lubricants cannot be used	Requires advanced processing method Might require special steel variants for roller screws Higher cost Well defined operating conditions to achieve expected performance



## Grease lubrication

Grease is the most common lubricant for screws. The grease type is primarily selected based on the requirements for operating temperature, load level, speed and environment.

Grease consists of base oil (average 80% of total grease volume) which is the lubricating agent, contained in a thickener matrix or soap, plus additives which provide special properties.

### Grease selection

Grease with a synthetic base oil is recommended over grease with a mineral base oil as it presents the advantages of greater stability over time and lower viscosity variation with changes of temperature.

The following synthetic oils provide good results for roller screw applications:

- Polyalphaolefins (PAO)
- Polyglycol (PAG)

Among many possible alternatives, the following thickeners achieve a good result with roller screw applications:

- Lithium or complex lithium
- Barium or complex barium

The dynamic viscosity characterizes the oil's ability to create a sufficiently thick hydrodynamic film between the contact surfaces of a screw. Lubricant data sheets usually provide the viscosity of the base oil at 40 °C and 100 °C.

In general, Ewellix recommends lubricants with a viscosity around 100 Cst when the application has reached its normal operating temperature.

Normal operating temperature is determined by the heat generated by the roller screw, any externally applied heat and the amount of heat that can be transferred away from the screw.

Grease consistency or NLGI grade between 0 (semi-fluid) and 2 (soft) is suitable for most applications. For automatic lubrication systems, Ewellix recommends checking the consistency required for the system to work properly.

For high speed applications and vertical applications which could cause the lubricant to fly off or pour down the shaft because of centrifugal forces, lubricants that will strongly adhere to the shaft are recommended. In this respect, barium soap and complex metallic soaps provide good adhe-

sive properties. In these conditions, NLGI grade 2 is also recommended to provide good consistency.

However, when rotating speed is low (below 10 r/min), high viscosity lubricants are recommended to enable the creation of a sufficiently thick hydrodynamic film between the rolling surfaces, and to limit friction under load. Ewellix usually recommends a viscosity above 300 Cst at the operating temperature.

Shearing of the hydrodynamic lubricant film is proportional to the load level. In general, for external load levels greater than 25% of the dynamic load carrying capacity of roller screws, Ewellix recommends greases with extreme pressure (EP) additives.

Greases that pass the "four balls welding load test" under a weight of 250 kg, will perform well in heavily loaded applications.

The following working conditions require specific greases:

- Food industry
- Vacuum applications
- Presence of water
- Vibrations
- Small movements, oscillations...

Ewellix lubrication systems can be adapted to most roller screws for automatic injection of grease.

## Lubrication schedule and procedure

Ewellix recommends the following lubrication schedule and procedure:

### 1. Commissioning and initial lubrication

New roller screws must be lubricated prior to use.

#### 1.1. Lubrication procedure for the shaft:

On the threaded length of the shaft, spread a volume of grease with a brush. The product tables (**pages 54 to 103**) provide the quantity of grease  $Z_s$  to be applied per meter of threaded length for each screw size.

This volume of grease is estimated using the following formula:

$$Z_s = 4,4 \times 10^{-4} d_0 l_1$$

where

$Z_s$  = grease volume [cm<sup>3</sup>]

$d_0$  = nominal diameter of the screw [mm]

$l_1$  = threaded length of the screw [mm]

## 1.2. Lubrication procedure for the nut:

Roller screws with a flanged nut have a threaded hole for a grease fitting. Roller screws with a cylindrical nut include a central groove and a lubrication hole that can be connected to a grease channel through the housing. During the initial lubrication, Ewellix recommends filling  $\frac{1}{3}$  rd of the free space in the nut with grease. The volume of grease to be injected is listed in the product tables in column  $Z_n$ .

Inject the grease in several steps, rotate the nut on the shaft or the shaft in the nut (several revolutions) between two grease injections in order to spread the grease between the rollers and to spread it over the nut length.

## 2. First relubrication

For non-preloaded screws, Ewellix recommends an additional injection volume of  $Z_n/2$  after 100 000 revolutions.

## 3. Lubrication maintenance schedule (after the first relubrication)

The following method describes the lubrication maintenance schedule and procedure for complete grease renewal, to be followed for the life of the roller screw, after the initial greasing operation and the first relubrication. This recommendation will optimize performance and extend the service life of the roller screw. This method is valid for screws working in an industrial environment, in a workshop, without external contaminants, and at ambient temperature not exceeding 40 °C.

A lubricant that does not completely meet the application requirements will require shorter relubrication intervals.

To avoid problems associated with grease compatibility (miscibility), always use the same type of grease. If, for whatever reason, it is necessary to switch to a different type of grease, check miscibility carefully.

When in doubt, thoroughly clean the nut and screw shaft.

### Note:

Grease applied to the length of the screw thread is usually not protected, which can accelerate aging and oxidation.

The parameters determining the relubrication intervals are:

- Speed: maximum rotational speed of the application
- Load: mean axial load carried by the screw in the application. The mean load can be calculated using the formulae detailed in **pages 44 to 50**.
- Temperature: internal temperature of the nut mechanism, usually the temperature measured on the outside surface of the nut, plus 15 °C.

If idle time is very long compared to operational time, the natural ageing and oxidation of the grease tends to change the grease condition, and decrease relubrication intervals. This case is not in the scope of following method.

The initial quantity of grease is the volume spread on the shaft plus the volume injected in the nut.

$$Z_o = Z_s + Z_n$$

The calculation of the lubrication intervals takes into account the actual operational time when the screw is in motion (idle time is not factored into that calculation).

The time before renewal of the initial quantity of grease is:

$$t_g = t_s K_T K_F$$

where

$t_g$  = Operational time before complete renewal of the initial quantity of grease

$t_s$  = Basic relubrication interval related to maximum speed.  $K_s$  can be estimated using **diagram 4**

$K_T$  = Correction factor related to roller screw maximum internal operating temperature.  $K_T$  can be estimated using **diagram 5**. This diagram applies to standard greases such as lithium based greases

$K_F$  = Correction factor related to screw mean operating load.  $K_F$  can be estimated using **diagram 6**, with consideration to the ratio of equivalent dynamic load to dynamic load carrying capacity  $F_m/C_a$ .

### Important:

The renewal of grease should be done incrementally. Once the relubrication quantity and total interval are determined, they must be fractioned over time in practical volume and intervals. Ewellix recommends applying small amounts of grease frequently rather than applying the full quantity in one operation.

If all the grease is renewed at once (which is not recommended), operate the roller screw at low speed to spread the grease over the full length of the screw.

If the consistency or viscosity of the grease changes rapidly, or if the temperature does not stabilize to an acceptable level, either the relubrication intervals must be shortened, or the grease is not suitable for the application conditions and another type of grease must be used.

Always rotate the shaft during periodic lubrication to distribute the grease evenly in the nut and the shaft. Rotating the shaft also prevents a roller from blocking the grease inlet hole.

Diagram 4

Basic relubrication interval  $t_s$  as a function of

- rotating speed [r/min]
- operational time [hours]
- nominal diameter  $d_0$  [mm]

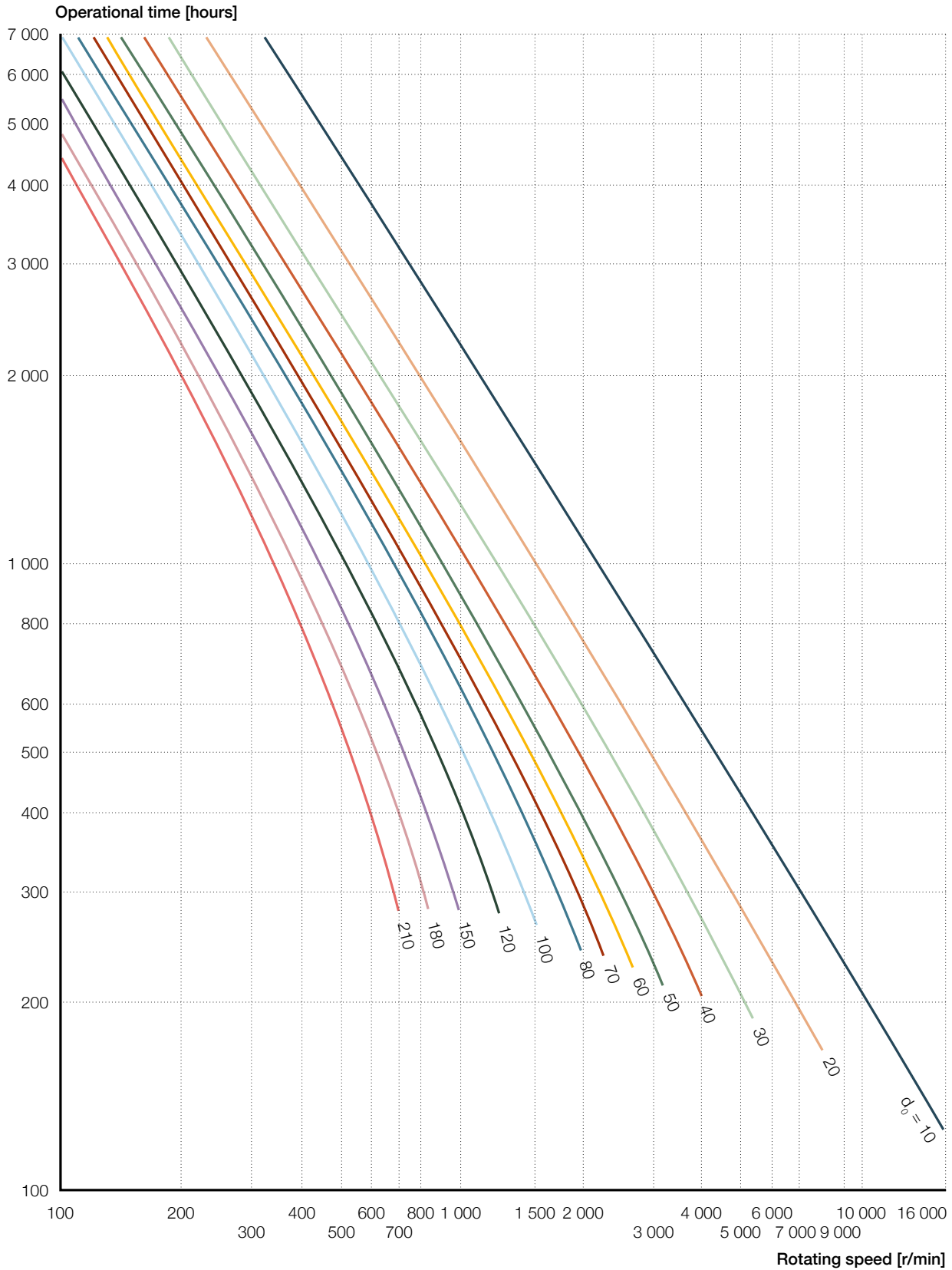

Diagram 5

Correction factor  $K_T$  for operating temperature

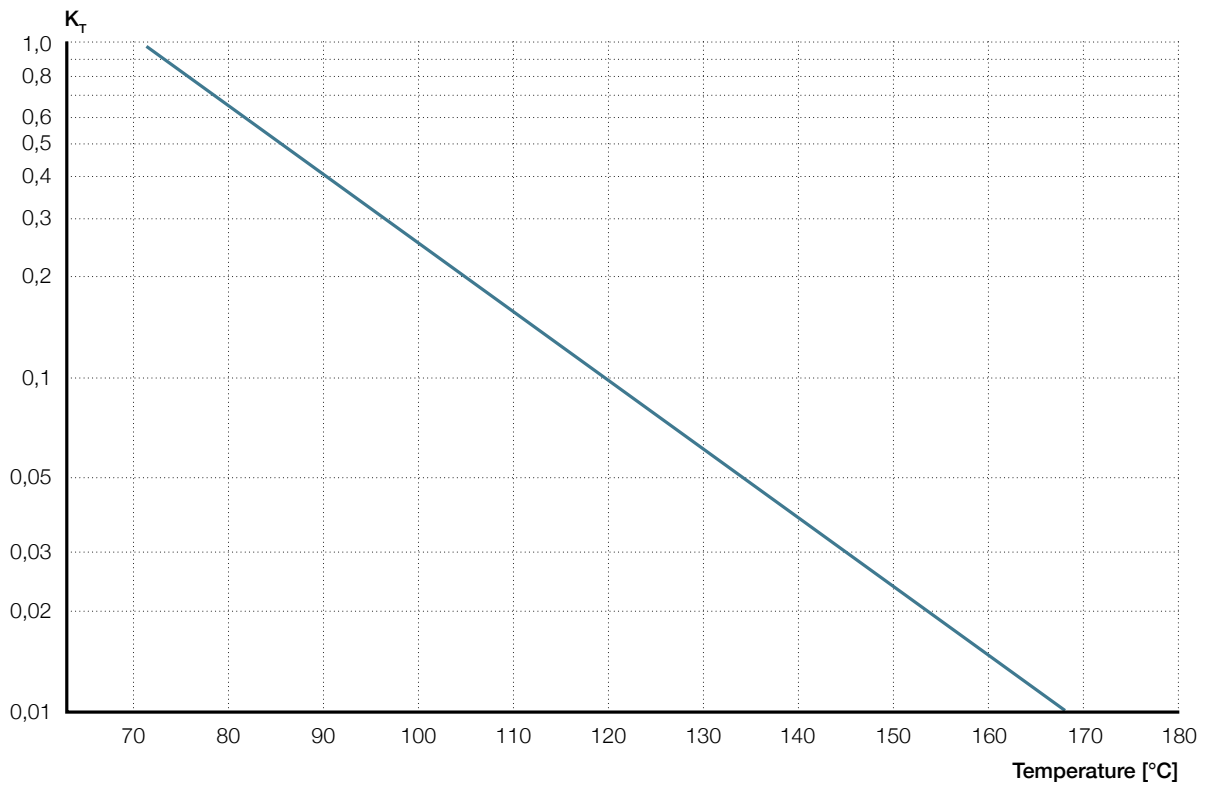
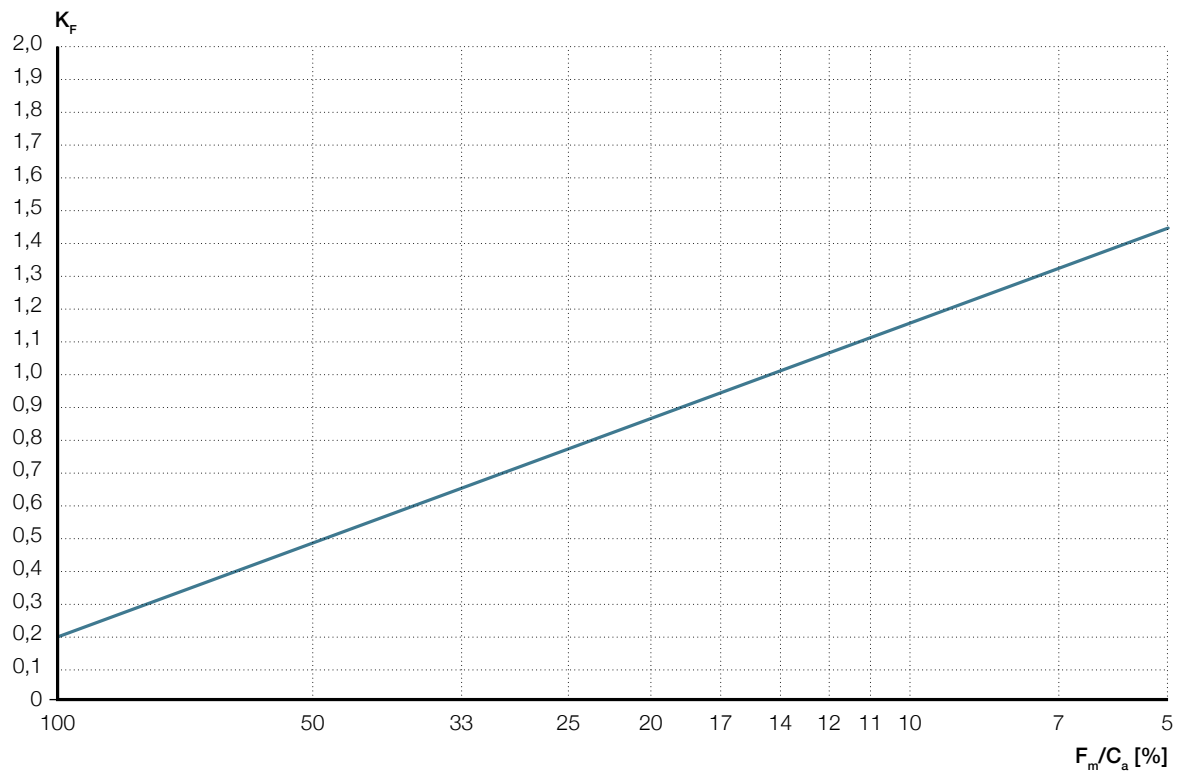

Diagram 6

Correction factor  $K_F$  for mean operating load



**Example:**

Roller screw SRF 39 x 20R 760/1030 G5 Z WPR is used in a simulator, in the vertical position, and operates according to following conditions:

- Mean axial load over one working cycle = 17 kN
- Each working cycle accomplishes 32 back -and-forth strokes of 1 000 mm (total travel of 32 000 mm per working cycle), operation is 12 working cycles per hour, 8 hours per day
- The screw is in motion during 70% of the time of a working cycle, i.e. 5,6 hours of motion per day
- Maximum speed = 1 500 r/min

For such application data, a grease with metallic complex soap or barium is recommended because it will improve adhesion under high speed and vertical position. A viscosity of 100 to 150 Cst at 40 °C is advised.

**Initial quantity of grease when commissioning the screw**

- Initial quantity of grease on the shaft  $Z_s = 4,4 \times 10^{-4} d_0 l_1 = 4,4 \times 10^{-4} \times 39 \times 760 = 13 \text{ cm}^3$  (see product table)
- Initial quantity of grease in the nut  $Z_n = 28 \text{ cm}^3$  (see product table)
- Total quantity of grease =  $13 + 28 = 41 \text{ cm}^3$  must be applied

**Calculation of first relubrication**

- With the given duty cycle, 100 000 revolutions are reached within one day
- $(32\ 000 / 20) = 1\ 600$  revolutions per working cycle
- 12 cycles per hour  $\hookrightarrow$  19 200 revolutions per hour
- 8 hours operation per day  $\hookrightarrow$  153 600 revolutions per day
- Approximately 1 day into operation, the first relubrication should be scheduled with  $14 \text{ cm}^3$  of new grease in the nut (half the initial volume of grease in the nut).

**Calculation of lubrication maintenance schedule**

•  $t_s$ :  
Maximum speed = 1 500 r/min  
From **diagram 7**, with 1 500 r/min and  $d_0 = 39 \text{ mm} \hookrightarrow K_S = 680 \text{ hours}$

•  $K_T$ :  
The temperature measured on the nut external surface = 65 °C  
 $\hookrightarrow$  Internal screw nut temperature  $\approx 80 \text{ °C}$   
From **diagram 8**  $\hookrightarrow K_T = 0,65$

•  $K_F$ :  
Dynamic load carrying capacity  $C_a$  of SRF 39 x 20R = 172 kN  
 $F_m / C_a = 17 / 172 \approx 10\%$

From **diagram 9**  $\hookrightarrow K_F = 1,15$

• Therefore, the maintenance lubrication schedule is:  
 $t_g = t_s K_T K_F = 680 \times 1,15 \times 0,65 = 508 \text{ hours} = 90 \text{ working days}$  ( $508 / 5,6 \approx 90$ )

Within a period of 90 days,  $41 \text{ cm}^3$  of new grease must be applied, to be divided in fractions applied on a regular basis.

Diagram 7

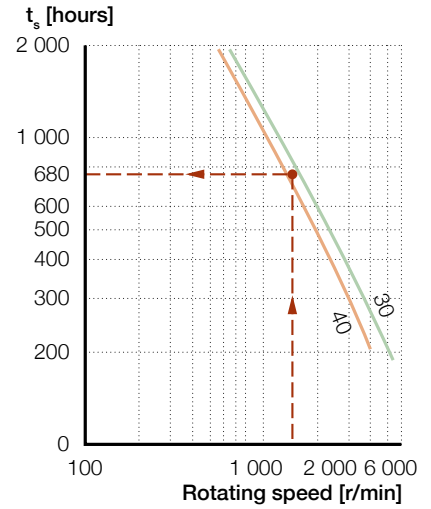

Diagram 8

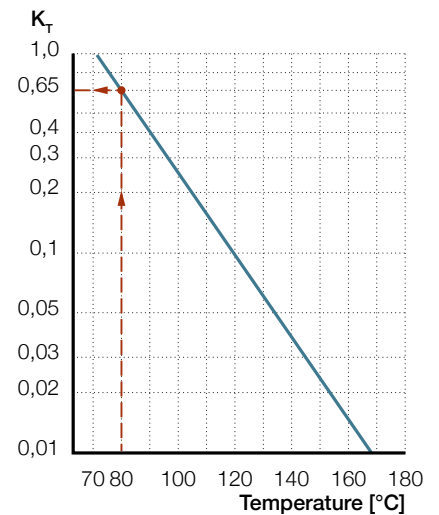
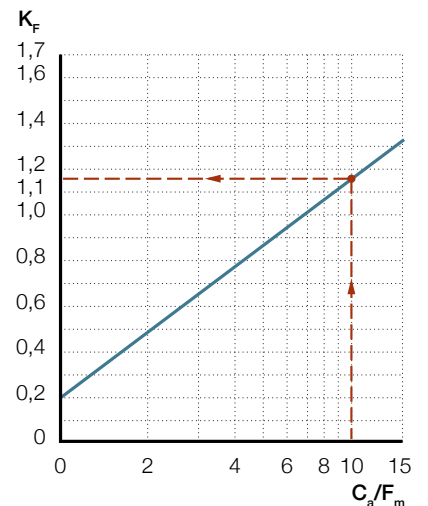

Diagram 9



## Oil lubrication

Oil lubrication provides the following advantages over grease lubrication.

Oil dissipates heat more efficiently than grease, particularly when there are heavy duty cycles and/or high speeds.

It helps to remove contaminants, and helps to clean the roller screw nut.

Lubricating a roller screw with oil is normally accomplished using a centralized recirculating oil system. This type of system is ideal because it continuously replaces the oil in the nut with cooled filtered oil coming from the reservoir. This system is recommended to control the flow of lubricant, remove any contaminants and avoid overheating.

### Oil selection

Oils used to lubricate other rotating parts such as bearings and especially gears can also be used to lubricate roller screws. Using hydraulic oils will jeopardize the product performance, condition and life.

The oil performance is affected by the rotational speed, the operating temperature and the load level.

The oil should have a viscosity of 100 Cst at the operating temperature. At low speed (below 10 r/min), the viscosity should be = 300 Cst at the operating temperature.

EP additives are recommended to improve the oil film strength.

Corrosion resistant and stabilizing additives are also recommended. Synthetic oils (PAO, polyglycol or ester based) are recommended for long service life and stable operation at high temperatures.

### Oil quantity

The quantity to be injected will depend on the size of the roller screw, the speed, the duty cycle and the sealing efficiency of the wipers. It can vary from 0,5 to 100 cm<sup>3</sup>/hour, with small injections of 0,1 to 1 cm<sup>3</sup>. It is best to adjust, by experience, the oil flow to obtain the correct stabilization temperature.

## Wipers

Wipers are composite components fitted at the ends of the nut with the purpose of preventing contamination and keeping the lubricant in place. Wipers are important components for roller screw performance and service life. It should be noted that standard wipers perform like labyrinth seals, not like garter seals. Depending on the product assortment, wipers are standard or optional (↳ fig. 5).

Standard wipers are manufactured from acetyl resin with continuous operating temperature up to 110 °C and peak temperature up to 140 °C (↳ tables 6 and 7).

### Important:

Normally, threaded wipers are not axially secured in the nut. If the maximum stroke position is not respected and the edge of wiper extends beyond the non-threaded portion of the screw, the wiper can disengage from the nut or potentially jam. For this reason, the user shall respect the maximum stroke position.

On request, wipers can be axially secured to a nut to prevent disengagement of the wipers during operation.

Fig. 5

Wiper

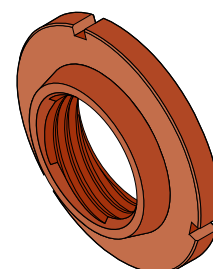

## Dry lubricants

When wet lubrication is not allowed or not effective (application examples: satellites, laboratories), dry lubricants present the following advantages:

- Low out-gassing (for example, satellite applications)
- Coefficient of friction independent of speed and temperature
- Positional stability
- Low rate of ageing (for example, during long storage periods)

Dry lubricants can be applied by projection, electrolytic deposit or physical vapour deposit.

Ewellix recommends thin deposits that will support a low coefficient of friction: these dry lubricants are usually based on PTFE, MoS<sub>2</sub>, WS<sub>2</sub>, graphite. These coatings are not corrosion resistant, and special care must be taken when selecting raw materials

Ewellix also recommends thin deposits that enhance the resistance to wear. Such dry lubricants are typically based on tungsten carbide, Diamond Like Carbon or chrome plating. They do not provide the low coefficient of friction of PTFE for example.

Dry lubricants (on a stand-alone basis) are not suitable for industrial grade or for heavy duty applications, and they cannot reach the rolling fatigue life achieved with grease or oil lubrication.

**Note:**

Lubrication that is performed at the customer facility after product delivery is outside the control of Ewellix. However, Ewellix provides the above guidelines to aid the customer in selecting a lubricant, and proper maintenance to provide maximum performance and product life. For additional information about lubricants and lubrication systems, please contact your local Ewellix representative.

Table 6

Standard wipers	
Roller screw types	Wipers in standard delivery (Acetyl resin material)
<b>Planetary SR/BR/PR</b>	To be specified in the designation
<b>Planetary Ultra Power HR</b>	Included
<b>Planetary IR (inverted)</b>	Not included and not an option (wipers cannot be fitted into this roller screw design, sealing can be integrated into the push tube)
<b>Planetary SRR (rotating nut)</b>	Included (wipers fitted in the roller screw nut, garter seals fitted in the bearings housing)
<b>Recirculating SV/BV/PV</b>	To be specified in the designation

Table 7

Special wipers	
Optional wiper design	Application
<b>PTFE material</b>	High operating temperatures: continuous temperature up to 200 °C, peak temperature up to 260 °C
<b>Tighter wiper</b>	Higher resistance to contaminants and better lubricant retention inside the nut
<b>Split (two half moons)</b>	Easier wiper disassembly on long, large diameter screws



5



Technical request  
form

# Technical request form

## Customer and project information

Company name .....

Address .....

Contact name ..... Phone number .....

Email ..... Website .....

Project name.....

Application type<sup>1)</sup> .....

Customer is not a subsidiary or part of National Defense industry<sup>1)</sup>  I agree

Application is not civil nuclear<sup>1)</sup>  I agree

Application is civil<sup>1)</sup>  I agree

Short description of application<sup>1)</sup>  
 (please attach a sketch if possible) .....

.....

.....

Current technology used for similar application.....

Annual roller screw requirements .....

Prototype requirements.....

Expected first delivery date.....

Expected prototype delivery date.....

## Preselection design parameters

Maximum stroke [mm]..... Preselection of screw shaft nominal diameter [mm] .....

Threaded length [mm]..... Preselection of lead Ph [mm].....

Total screw shaft length [mm] ..... Lead precision grade according to ISO 3408.....

Screw type (planetary, inverted, rotating nut, recirculating) ..... Axial play (standard or specific), without backlash or with preload.....

Nut shape (cylindrical, centered flange, off-centered flange, split nut, double nut) .....

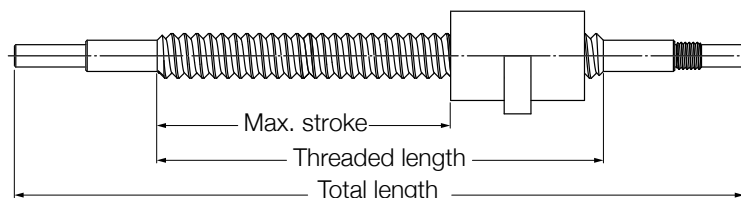

<sup>1)</sup> This information must be provided.

### Operating conditions

#### Environmental constraints

- Corrosive
- Polluted
- Vacuum
- Other

#### Operating temperature

Minimum.....°C    Maximum.....°C  
 Average.....°C    Ambient.....°C

#### Lubrication

- Oil                       Grease
- Dry lubricant         Specific lubrication needed

If lubricant is already selected

Brand name.....  
 Type .....  
 Viscosity at average operating temperature.....Cst

#### Maximum loads, speed and acceleration

Maximum dynamic tension load .....N  
 Maximum dynamic compression load.....N  
 Maximum static or shock tension load.....N  
 Maximum static or shock compression load.....N  
 Maximum linear speed .....m/min  
 Maximum acceleration .....m/s<sup>2</sup>

#### Service life

Stroke (1 cycle = 2 strokes) ..... mm  
 Cycles/hour.....  
 Hours/day.....  
 Days/year .....  
 Years .....

### Duty cycle description

Load [kN] / Speed [mm/s]

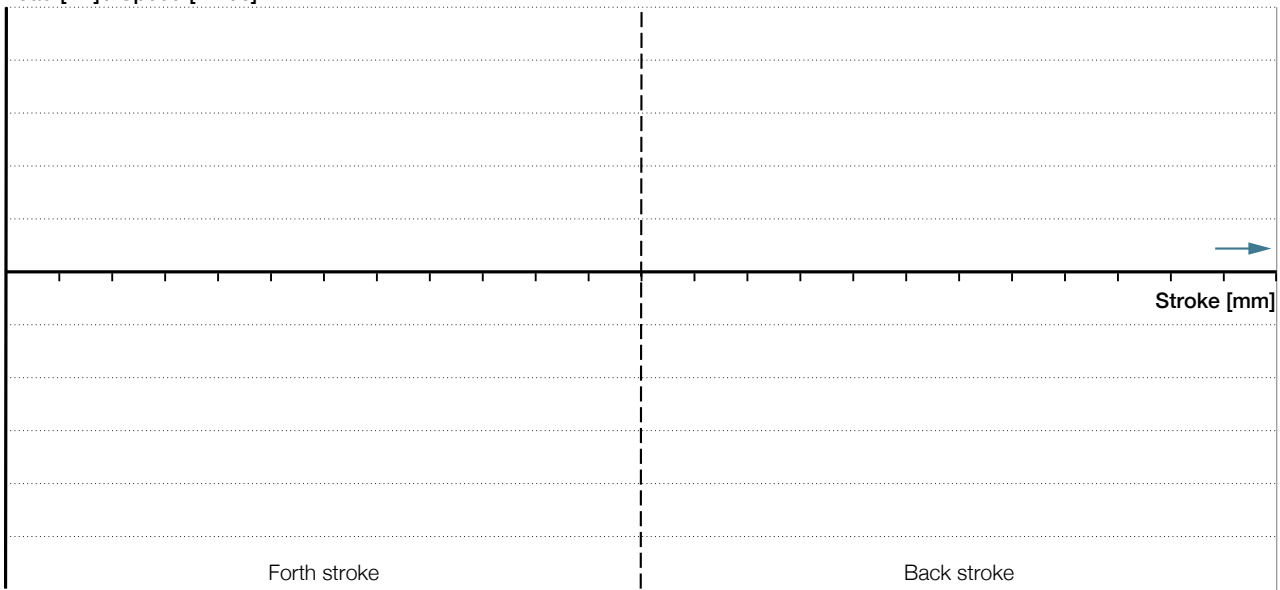

### Mounting conditions

- Position of the screw                       Vertical                                       Horizontal
- Rotating component                       Screw shaft                                 Nut
- Screw end mounting conditions            ●●————                                    (fixed, free)
- (fixed, radial support)
- (fixed, fixed)

### Other pertinent information

.....  
 .....  
 .....

Ball screw catalogue, ball screw 2D prints and 3D models are available on [www.ewellix.com](http://www.ewellix.com)  
 Please send inquiry form to your Ewellix sales office. For contact information, please visit [www.ewellix.com](http://www.ewellix.com)

6

Symbols

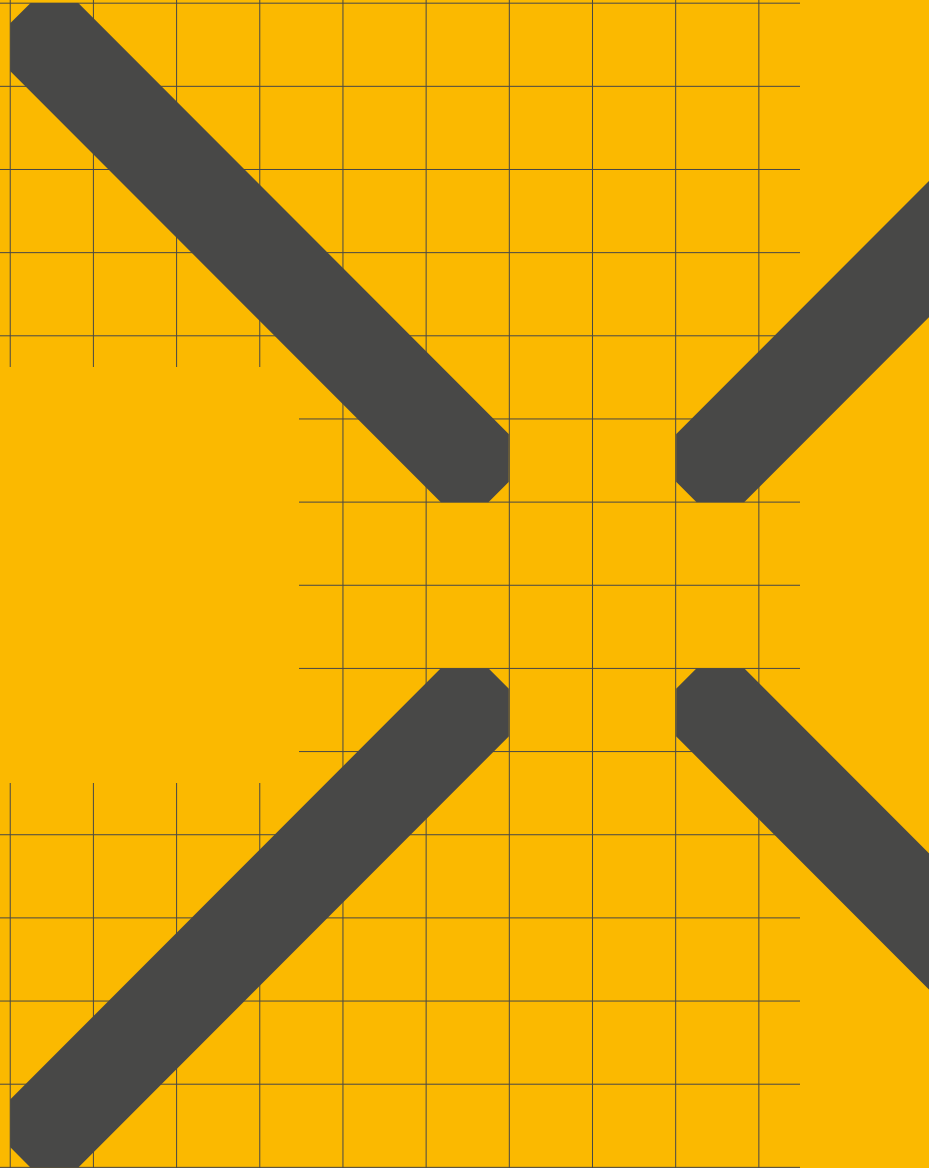

# Symbols

<b>a</b>	[°]	Helix angle of the thread
<b>η</b>	–	Theoretical direct efficiency
<b>η'</b>	–	Theoretical indirect efficiency
<b>η<sub>p</sub></b>	–	Practical direct efficiency
<b>η'<sub>p</sub></b>	–	Practical indirect efficiency
<b>μ<sub>prac</sub></b>	–	Practical coefficient of friction
<b>μ<sub>ref</sub></b>	–	Reference coefficient of friction
<b>μ<sub>s</sub></b>	–	Coefficient of friction when starting
<b>σ</b>	[MPa]	Nominal axial stress
<b>σ<sub>p</sub></b>	[MPa]	Real axial stress
<b>σ<sub>t</sub></b>	[MPa]	Total stress
<b>t</b>	[MPa]	Nominal shear stress
<b>t<sub>p</sub></b>	[MPa]	Real shear stress
<b>B</b>	[mm]	Wiper overhang (protuding from nut length A)
<b>C<sub>0a</sub></b>	[kN]	Static load carrying capacity of a roller screw
<b>C<sub>a</sub></b>	[kN]	Dynamic load carrying capacity of a roller screw
<b>C<sub>req</sub></b>	[kN]	Required basic dynamic load carrying capacity
<b>D<sub>0</sub></b>	[mm]	Nominal nut diameter for an inverted roller screw
<b>D<sub>2</sub></b>	[mm]	Wiper outside diameter (= inner diameter of wiper recess)
<b>D<sub>3</sub></b>	[mm]	Wiper outside diameter in the plane of nut end face
<b>d<sub>0</sub></b>	[mm]	Nominal diameter of screw shaft
<b>d<sub>1</sub></b>	[mm]	Outside diameter of screw shaft
<b>d<sub>2</sub></b>	[mm]	Root diameter of screw shaft
<b>d<sub>b</sub></b>	[mm]	Bore diameter of a hollow screw shaft
<b>e</b>	[mm]	Depth of the keyway on shaft end machining
<b>F</b>	[N]	Axial load
<b>F<sub>c</sub></b>	[N]	Buckling strength
<b>F<sub>m</sub></b>	[N]	Equivalent constant cubic mean axial load
<b>F<sub>pr</sub></b>	[N]	Internal preload force between a nut half (or a nut) and the shaft
<b>F<sub>q</sub></b>	[N]	Squeeze load applied to two nut halves (or two nuts) by the housing or by fixing bolts
<b>f<sub>1</sub></b>	–	Mounting factor for calculation of critical speed of screw shaft
<b>f<sub>3</sub></b>	–	Mounting factor for calculation of buckling strength of screw shaft
<b>f<sub>4</sub></b>	–	Stress concentration factor for shaft end calculation for torsional stress
<b>f<sub>5</sub></b>	–	Stress concentration factor for shaft end calculation for axial stress
<b>g</b>	[m/s <sup>2</sup> ]	Acceleration of gravity = 9,8 m/s <sup>2</sup>
<b>HRC</b>	HRC	Rockwell hardness
<b>HV</b>	HV	Vickers hardness
<b>I</b>	[kgm <sup>2</sup> ]	Inertia
<b>I<sub>L</sub></b>	[kgm <sup>2</sup> ]	Inertia of load
<b>I<sub>M</sub></b>	[kgm <sup>2</sup> ]	Inertia of motor
<b>I<sub>nn</sub></b>	[kgmm <sup>2</sup> ]	Inertia of a rotating nut
<b>I<sub>ns</sub></b>	[kgmm <sup>2</sup> ]	Inertia of rollers with rotating shaft
<b>I<sub>s</sub></b>	[kgmm <sup>2</sup> /m]	Inertia of screw shaft per meter of shaft length
<b>K<sub>F</sub></b>	–	Correction factor for basic relubrication interval to account for operating load
<b>K<sub>s</sub></b>	[h]	Basic relubrication interval related to maximum spee
<b>K<sub>T</sub></b>	–	Correction factor for basic relubrication interval to account for operating temperature
<b>L</b>	[mm]	Length of stroke in a duty cycle
<b>L<sub>10</sub></b>	[10 <sup>6</sup> revolutions]	L <sub>10</sub> basic life rating, millions of revolutions
<b>L<sub>10h</sub></b>	[h]	L <sub>10h</sub> basic life rating, operating hours
<b>L<sub>n</sub></b>	[10 <sup>6</sup> revolutions]	Calculated life with reliability factor
<b>L<sub>tp</sub></b>	[mm]	Maximum total shaft length
<b>l<sub>0</sub></b>	[mm]	Nominal travel: Nominal lead multiplied by the number of revolutions
<b>l<sub>1</sub></b>	[mm]	Threaded length
<b>l<sub>cr</sub></b>	[mm]	Free length, or distance between the two supports for shaft critical speed calculation

$l_{rs}$	[mm]	Length of roller set in an inverted roller screw
$m_L$	[kg]	Mass of the load
$m_n$	[kg]	Mass of the nut with standard number of rollers
$m_s$	[kg/m]	Mass of the screw shaft per meter
$n_{cr}$	[r/min]	Critical speed
$P$	[W]	Power
$P_h$	[mm]	Lead of a roller screw
$Q$	[mm]	Fixing hole for the grease fitting, or lubrication hole for cylindrical nuts
$R_n$	[N/ $\mu$ m]	Nut stiffness
$R_{ng}$	[N/ $\mu$ m]	Minimum nominal stiffness of a nut assembly
$R_{nr}$	[N/ $\mu$ m]	Reference nominal stiffness of a nut assembly
$R_s$	[N/ $\mu$ m]	Shaft stiffness
$R_t$	[N/ $\mu$ m]	Static axial stiffness of the roller screw assembly
$S$	[mm]	Maximum stroke for an inverted roller screw
$S_{ap}$	[mm]	Maximum axial play
$T$	[Nm]	Input torque in steady state
$T_b$	[Nm]	Back-driving and braking torque
$T_{be}$	[Nm]	Torque without backlash
$T_f$	[Nm]	Torque from friction in support bearings, motor, seals, etc.
$T_{pr}$	[Nm]	Preload torque
$T_t$	[Nm]	Total driving torque
$u$	[°]	Angular position of lubrication hole on flanged nut
$Z_0$	[cm <sup>3</sup> ]	Total grease quantity for the screw shaft and the nut
$Z_n$	[cm <sup>3</sup> ]	Grease quantity for the nut
$Z_s$	[cm <sup>3</sup> ]	Grease quantity for screw shaft

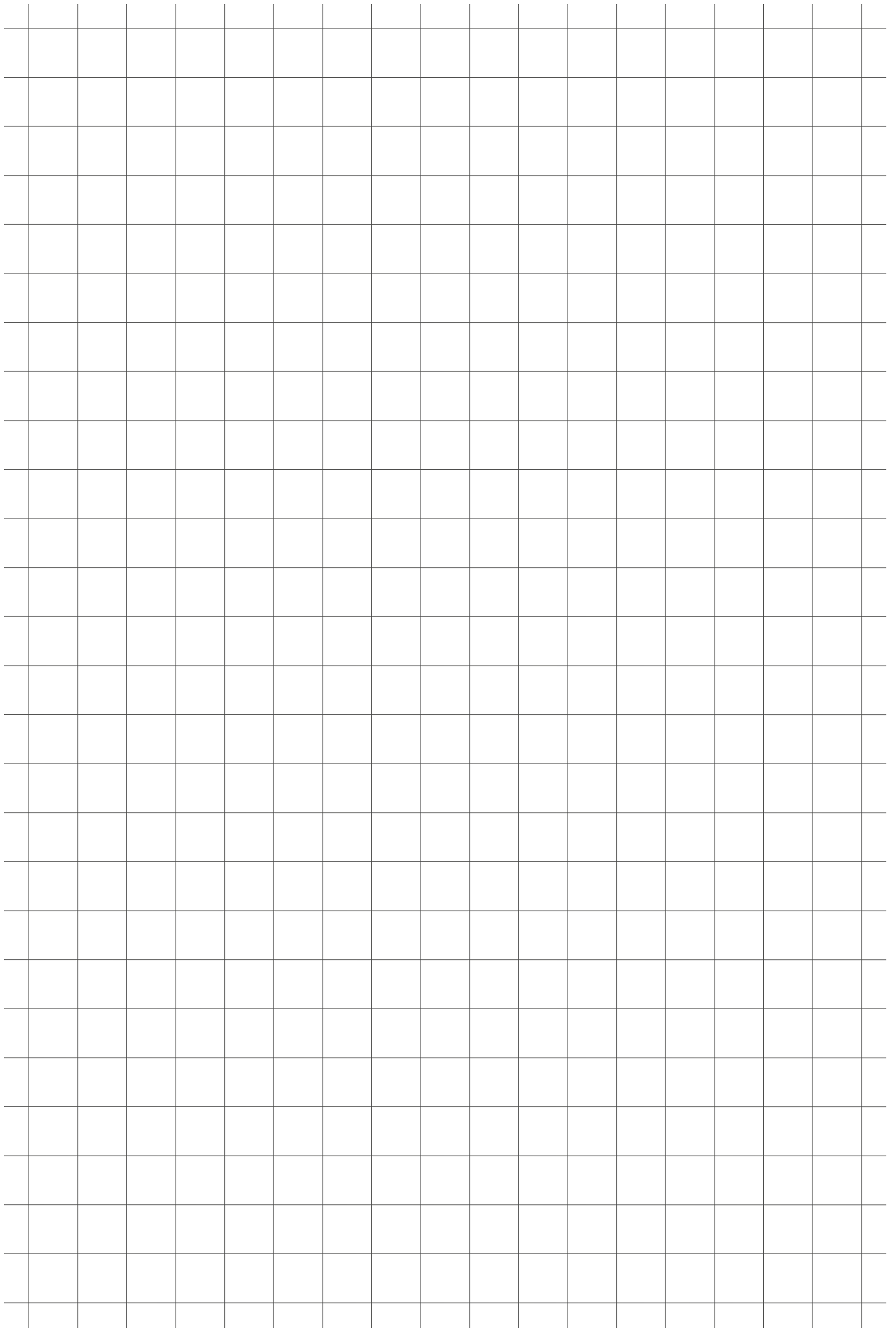

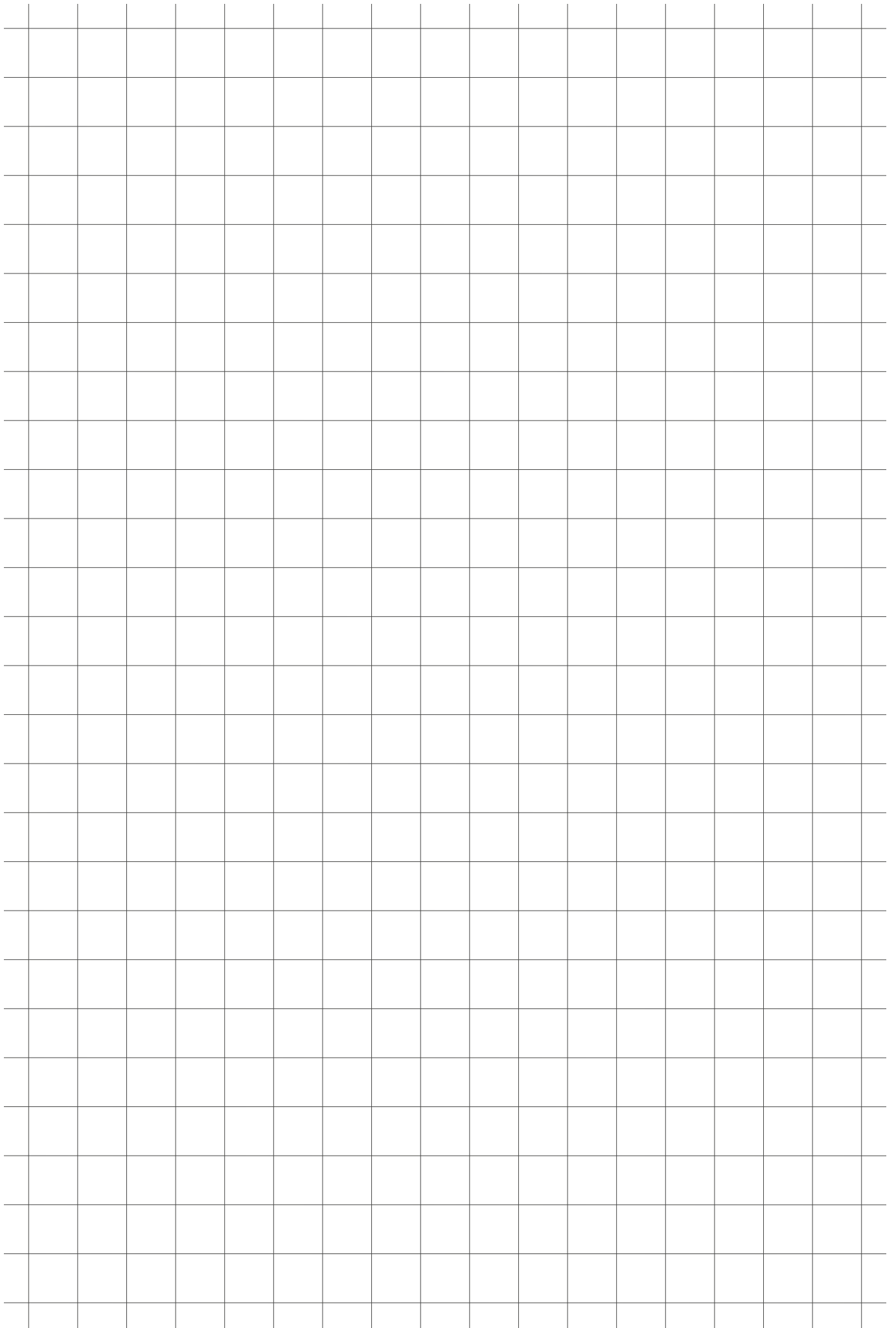

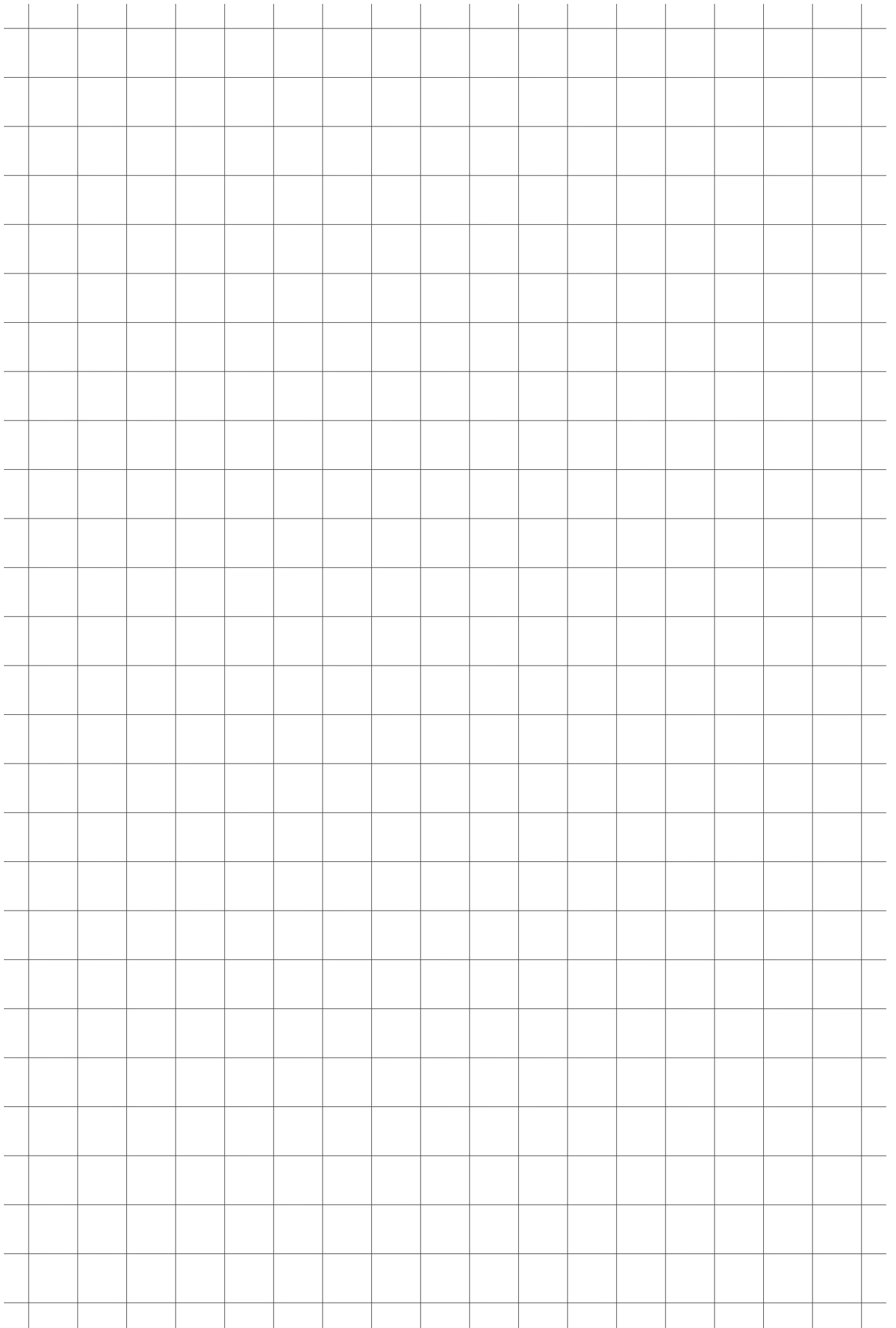

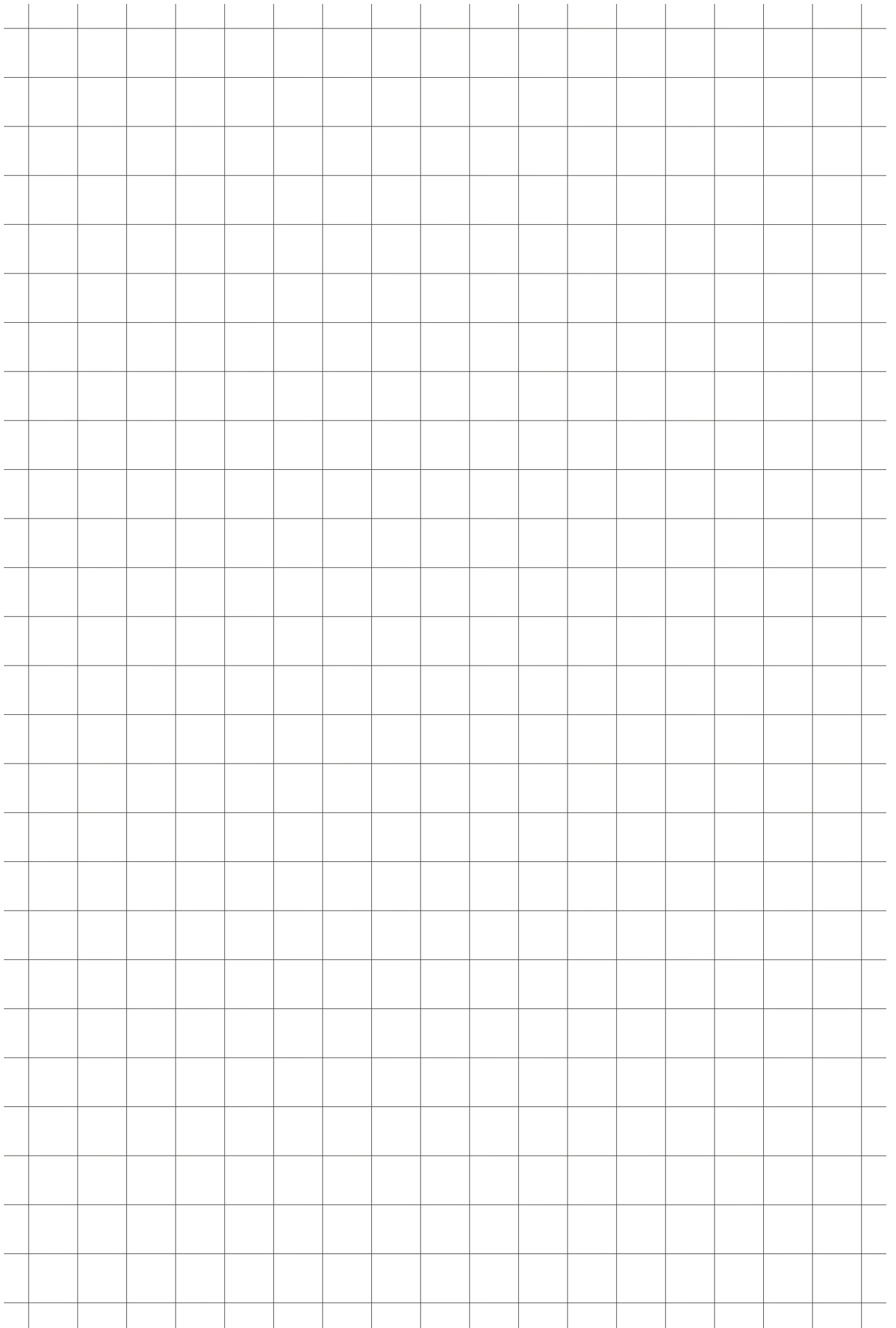





## ewellix.com

© Ewellix

All contents of this publication are the property of Ewellix, and may not be reproduced or given to third parties (even extracts) without permission. Although great care has been taken in the production of this catalog, Ewellix does not take any responsibility for damage or other loss resulting from omissions or typographical errors. The photo may differ slightly in appearance from the actual product. Due to continuous improvements being made in our products, the product's appearance and specifications are subject to change without notice.

**PUB IL-05003-EN-October 2019**

Certain image(s) used under license from Shutterstock.com.  
SKF and SKF logo are trademarks of the SKF Group