

Linear bearings, units and shafts catalogue



Contents

1 Introduction	4	3.6 Shaft blocks and shaft supports	81
1.1 Product overview	5	3.6.1 Shaft blocks - LSCS	82
1.1.1 Compact linear ball bearings and units	5	3.6.2 Compact shaft blocks - LSHS	83
1.1.2 Standard linear ball bearings and units	5	3.6.3 Standard shaft blocks - LSNS	84
2 Selection guide	12	3.6.4 Compact tandem shaft blocks - LEBS	85
2.1 Technical and calculation data	13	3.6.5 Standard tandem shaft blocks- LEAS	86
2.1.1 Permissible operating conditions.....	13	3.6.6 Standard shaft supports - LRCB/LRCC	87
2.1.2 Calculation bases and factors of influence	13	3.7 Precision shafts	88
3 Product range	18	3.8 Linear slides	95
3.1 Compact linear bearings	19	3.8.1 Linear slides - LZBU A	96
3.1.1 Compact linear ball bearings - LBBR	20	3.8.2 Linear slides - LZBU B	98
3.1.2 Compact linear plain bearings - LPBR	22	3.8.3 Linear slides - LZAU	100
3.1.3 External shaft seals for compact bearings	23	4 Mounting, operation and maintenance manual	102
3.2 Compact linear units	24	4.1 Design rules	103
3.2.1 Compact linear units – LUHR	26	4.1.1 How to use linear bearings.....	103
3.2.2 Compact linear units – LUJR	28	4.1.2 Radial location.....	103
3.2.3 Compact tandem units - LTBR	30	4.1.3 Axial location.....	104
3.2.4 Compact duo units - LTDR	32	4.1.4 Axial and rotational fixation	105
3.2.5 Compact quadro units - LQBR	34	4.1.5 Sealing.....	108
3.3 Standard linear ball bearings	36	4.2 Mounting of linear ball bearings	109
3.3.1 Standard linear ball bearings - LBCD	40	4.2.1 Preparation for mounting.....	109
3.3.2 Standard linear ball bearings - LBCT	42	4.2.2 Mounting.....	110
3.3.3 Standard linear ball bearings - LBCF	44	4.3 Maintenance	111
3.3.4 Standard linear ball bearings - LBHT.....	46	4.3.1 Stationary conditions, shipping and storage	111
3.3.5 Standard linear plain bearings - LPAR/LPAT	48	5 Customer specification sheet.....	112
3.3.6 Grease fittings - VN-LHC	50		
3.4 Standard linear units.....	51		
3.4.1 Standard linear units - LUCR/LUCD	54		
3.4.2 Standard linear units - LUCS/LUCE	56		
3.4.3 Standard linear units - LUCT/LUCF	58		
3.4.4 Standard linear units - LUCT BH	60		
3.4.5 Standard linear units - LUNR/LUND	62		
3.4.6 Standard linear units - LUNS/LUNE	64		
3.4.7 Standard linear units - LUNT/LUNF	66		
3.4.8 Standard flanged units - LVCR/LVCD	68		
3.4.9 Standard tandem units - LTCR/LTCD	70		
3.4.10 Standard tandem units - LTCT/LTCF	72		
3.4.11 Standard quadro units - LQCR/LQCD	74		
3.4.12 Standard quadro units - LQCT/LQCF	76		
3.5 Standard housings	78		
3.5.1 Standard housings - LHCR/LHCS	79		
3.5.2 Standard housings - LHCT	80		

The heritage of innovation

Ewellix is a global innovator and manufacturer of linear motion and actuation solutions. Today, our state-of-the-art linear solutions are designed to increase machine performance, maximise uptime, reduce maintenance, improve safety and save energy.

Technology leadership

Our journey began over 50 years ago as part of the SKF Group, and our history with SKF provided us with the expertise to continuously develop new technologies and use them to create cutting edge products that offer our customers a competitive advantage.

In 2019, we became independent from SKF and changed our name to Ewellix. We are proud of our heritage. This gives us a unique foundation on which to build an agile business with engineering excellence and innovation as our core strengths.

Global presence and local support

With our global presence, we are uniquely positioned to deliver standard components and custom-engineered solutions, with full technical and applications support around the world. Long standing relationships with our distributor partners allow us to support customers in a variety of different industries. At Ewellix, we don't just provide products; we engineer integrated solutions that help customers realise their ambitions.

 **1 400 employees**

 **16 sales units**

 **9 factories**

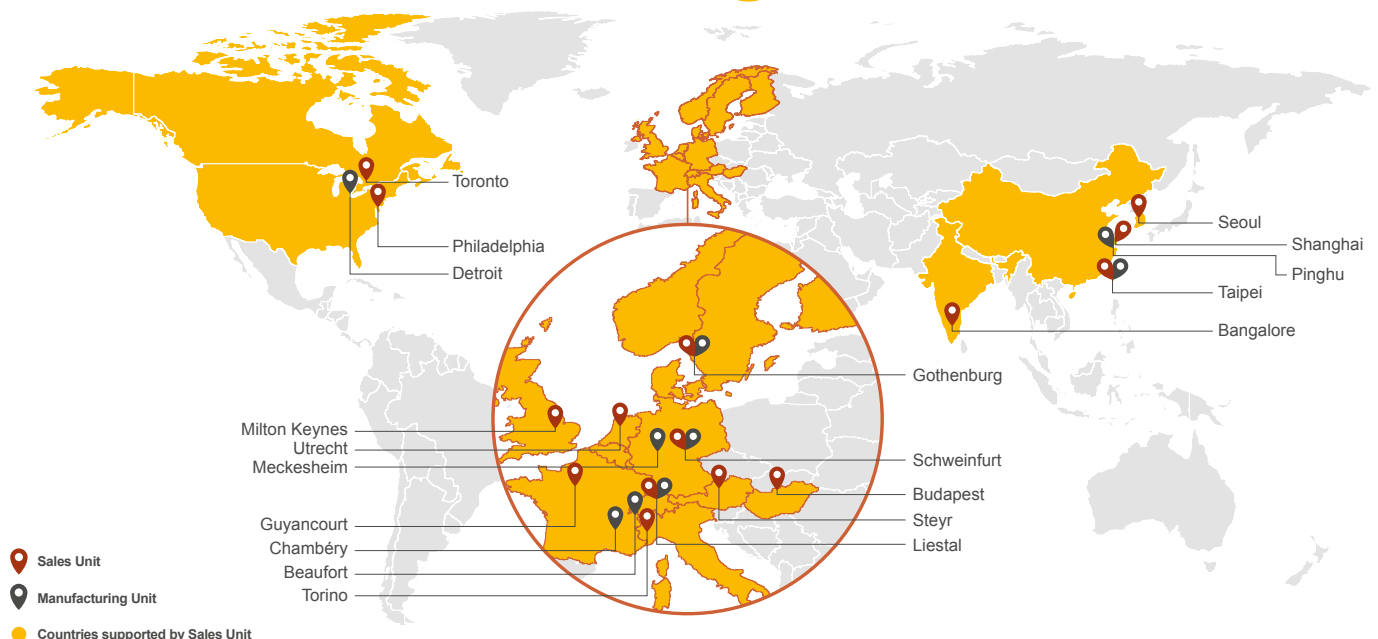

Trusted engineering expertise

Our industry is in motion; pushing towards solutions that reduce environmental impact and leverage new technology. We provide technical and manufacturing expertise to overcome our customers' challenges.

Engineering for the future

We work in a wide range of industries, where our solutions provide key functionality for business critical applications.

For the medical industry, we provide precision components for use in core medical equipment.

Our unparalleled understanding of industrial automation systems is based on decades of research into advanced automation components and techniques

Our deep knowledge of mobile machinery provides powerful and reliable electromechanical solutions for the harshest conditions. In an industrial distribution setting, we supply linear expertise to our partners, empowering them to serve customers with greater efficiency

We offer excellence

We have a unique understanding of linear equipment and how it's integrated in customers' applications to provide the best performance and machine efficiency.

We assist our customers by creating equipment that runs faster, longer and safer and that is sustainable.

We provide a wide variety of linear motion components and electromechanical actuators for equipping any automation application, helping our customers reduce its footprint, energy use and maintenance.

We push for lower energy consumption that increases productivity and reduces the environmental impact.

Actuation systems



Ball and roller screws



Linear guides and systems

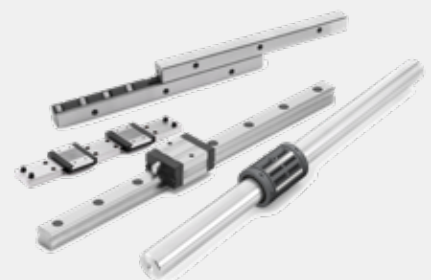

1

Introduction

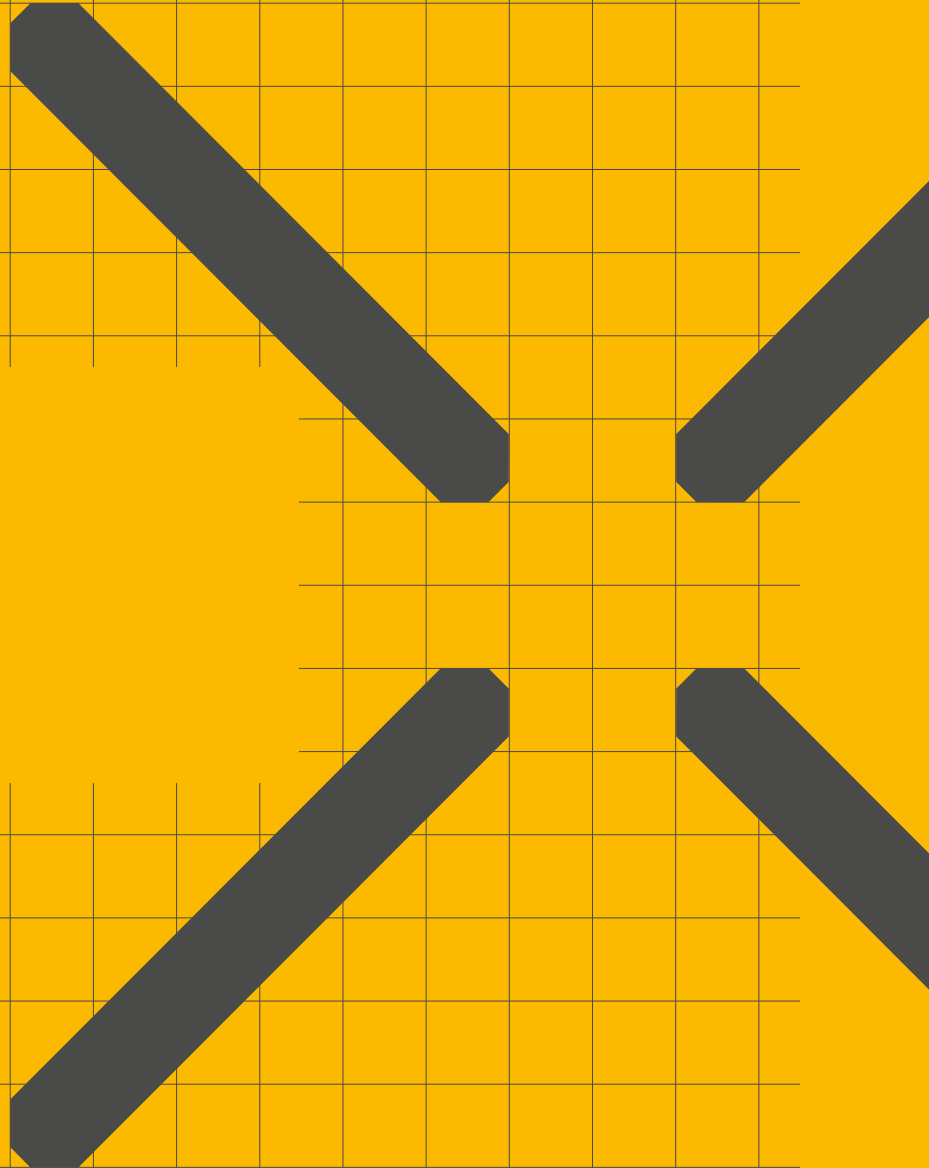

1.1 Product overview

This catalogue includes Ewellix compact and standard linear ball bearings, manufactured according to ISO 10285, and linear plain bearings with the same dimensions. The linear ball bearings, the linear bearing units and accessories can be used to design economic linear guiding systems for a wide variety of applications.

1.1.1 Compact linear ball bearings and units

Compact linear ball bearings LBBR have a small cross section and are easy to mount. These bearings, equipped with seals or shields, are available standard and also in stainless steel variants. Linear ball bearing units in this range, which include a bearing and housing, are available in single, tandem, duo and quadro versions.

1.1.2 Standard linear ball bearings and units

Standard linear ball bearings include the cylindrical LBCR and LBCT design, the self-aligning LBCD and LBCF design and the LBHT design with extra high load rating. Any of the bearings in the ISO standard are available in standard and stainless steel variants, with integrated double lip seals or with shields. These linear ball bearings are interchangeable with all former Ewellix standard bearings.

There is a wide variety of linear bearing units: single, tandem and quadro units in different variants. The single units are available with different housing types as well as slotted for adjustable clearance.

Linear plain bearings and units

Ewellix offers linear plain bearings in both ISO series. The closed linear plain bearings LPBR are included in the compact range. Closed LPAR and open LPAT linear plain bearings belong to the standard range. Most types of linear bearing units can be equipped with linear plain bearings, too.

Factory pre-lubrication

Ewellix linear ball bearings and units for shaft diameter 8 mm and larger are factory pre-lubricated by default. This saves assembly time and maintenance effort. The linear ball bearings are lubricated with the high-performance grease LGEP2 from SKF that is suitable for a wide range of industrial and automotive applications. The grease is based on lithium soap and mineral oil, whereas the extreme pressure additives provide a good anti-wear protection and corrosion resistance. Special greases for food or clean room environments are available on request. Linear ball bearings without factory pre-lubrication can be ordered by using suffix “/VT808”, e.g. LBCR 20 D-2LS/VT808. Before mounting non pre-greased linear bearings, they have to be suitably lubricated.

Ewellix linear ball bearings are always protected with a corrosion inhibiting preservative for transport and storage. This preservative is not food-grade.

Please note that linear ball bearings LBBR 6, LBCR 6 and LBCR 5 are factory pre-lubricated with oil (Paraliq P460 from Klueber), by default. LBBR 3, 4 and 5 are without lubricant by default but are also protected with a preservative for transport and storage as with the other bearings.

Further linear guides from Ewellix

In cases where, for example, load conditions are such that these bearings and units cannot be used, other Ewellix linear guides and systems are available. For additional information regarding these products, visit our homepage or contact your local Ewellix representative.



Linear ball bearings

Picture ¹⁾	Designation	Size mm	Max load rating dynamic / static N	Comments	ISO series	Chapter
	LBBR	3 to 50	7 100 / 6 950	–	1	Chapter 3.1.1
	LBCR	5 to 80	37 500 / 32 000	–	3	Chapter 3.3.1
	LBCD	12 to 50	11 200 / 6 950	Self-aligning ²⁾	3	Chapter 3.3.2
	LBCT	12 to 80	37 500 / 32 000	–	3	Chapter 3.3.3
	LBCF	12 to 50	11 200 / 6 950	Self-aligning ²⁾	3	Chapter 3.3.4
	LBHT	20 to 50	17 300 / 17 000	Self-aligning ²⁾	3	Chapter 3.3.5





¹⁾Picture of non D-series bearing differs

²⁾Automatic compensation of shaft misalignments of up to max. ± 30 minutes of arc (↳ [chapter 3.3](#))

Linear plain bearings





Picture	Designation	Size	Max load rating dynamic / static	Comments	ISO series	Chapter
–	–	mm	N	–	–	–
	LPBR	12 to 50	10 800 / 38 000	–	1	Chapter 3.1.2
	LPAR	5 to 80	33 500 / 116 000	–	3	Chapter 3.3.6
	LPAT	12 to 80	33 500 / 116 000	–	3	Chapter 3.3.6

Compact linear units

Picture ¹⁾	Housing	Designation	Bearing	Size	Max load rating dynamic / static	Chapter
–	–	–	–	mm	N	–
	Closed, aluminium housing	LUHR LUHR PB	LBBR bearing LPBR, plain bearing	12 to 50 12 to 50	7 100 / 6 950 10 800 / 38 000	Chapter 3.2.1
	Closed, aluminium housing with shaft seals	LUJR LUJR PB	LBBR bearing LPBR, plain bearing	12 to 50 12 to 50	7 100 / 6 950 10 800 / 38 000	Chapter 3.2.2
	Tandem, closed, aluminium housing	LTBR LTBR PB	LBBR bearing LPBR, plain bearing	12 to 50 12 to 50	11 600 / 14 000 21 600 / 76 000	Chapter 3.2.3
	Duo, closed, aluminium housing	LTDR LTDR PB	LBBR bearing LPBR, plain bearing	12 to 50 12 to 50	11 600 / 14 000 21 600 / 76 000	Chapter 3.2.4
	Quadro, closed, aluminium housing	LQBR LQBR PB	LBBR bearing LPBR, plain bearing	12 to 50 12 to 50	19 000 / 28 000 43 200 / 152 000	Chapter 3.2.5





¹⁾ Picture of plain bearing differs

Standard linear units

Picture ¹⁾	Housing	Designation	Bearing	Size	Max load rating dynamic / static	Chapter
-	-	-	-	mm	N	
	Closed, die-casted aluminium housing	LUCR	LBCR bearing	8 to 80	37 500 / 32 000	Chapter 3.4.1
		LUCD	LBCD bearing, self-aligning ²⁾	12 to 50	11 200 / 6 950	
		LUCR PA	LPAR, plain bearing	8 to 80	33 500 / 116 000	
	Closed, die-casted aluminium housing, clearance adjustable	LUCS	LBCR bearing	8 to 80	37 500 / 32 000	Chapter 3.4.2
		LUCE	LBCD bearing, self-aligning ²⁾	12 to 50	11 200 / 6 950	
	Open, die-casted aluminium housing	LUCT	LBCT bearing	12 to 80	37 500 / 32 000	Chapter 3.4.3
		LUCF	LBCF bearing, self-aligning ²⁾	12 to 50	11 200 / 6 950	
		LUCT PA	LPAT, plain bearing	12 to 80	33 500 / 116 000	
	Heavy duty, open, die-casted aluminium housing	LUCT BH	LBHT bearing, heavy duty	20 to 50	17 300 / 17 000	Chapter 3.4.4
	Closed, aluminium housing	LUNR	LBCR bearing	12 to 50	13 400 / 12 200	Chapter 3.4.5
		LUND	LBCD bearing, self-aligning ²⁾	12 to 50	11 200 / 6 950	
		LUNR PA	LPAR, plain bearing	12 to 50	12 700 / 45 000	
	Closed, aluminium housing, clearance adjustable	LUNS	LBCR bearing	12 to 50	13 400 / 12 200	Chapter 3.4.6
		LUNE	LBCD bearing, self-aligning ²⁾	12 to 50	11 200 / 6 950	
	Open, aluminium housing	LUNT	LBCT bearing	12 to 50	13 400 / 12 200	Chapter 3.4.7
		LUNF	LBCF bearing, self-aligning ²⁾	12 to 50	11 200 / 6 950	
		LUNT PA	LPAT, plain bearing	12 to 50	12 700 / 45 000	
	Flanged, cast iron housing	LVCR	LBCR bearing	12 to 80	37 500 / 3 000	Chapter 3.4.8
		LVCD	LBCD bearing, self-aligning ²⁾	12 to 50	11 200 / 6 950	
		LVCR PA	LPAR, plain bearing	12 to 80	33 500 / 116 000	

¹⁾ Picture of non D-series bearing or plain bearing differs





²⁾ Automatic compensation of shaft misalignments of up to max. ± 30 minutes of arc (→ **chapter 3.3**)

Picture ¹⁾	Housing	Designation	Bearing	Size	Max load rating dynamic / static	Chapter
–	–	–	–	mm	N	
	Tandem, closed, aluminium housing	LTCT	LBCT bearing	12 to 50	21 600 / 24 500	Chapter 3.4.9
		LTCD	LBCD bearing, self-aligning ²⁾	12 to 50	18 300 / 14 000	
		LTCT PA	LPAR, plain bearing	12 to 50	25 400 / 90 000	
	Tandem, open, aluminium housing	LTCT	LBCT bearing	12 to 50	21 600 / 24 500	Chapter 3.4.10
		LTCTF	LBCF bearing, self-aligning ²⁾	12 to 50	18 300 / 14 000	
		LTCT PA	LPAT, plain bearing	12 to 50	25 400 / 90 000	
	Quadro, closed, aluminium housing	LQCT	LBCT bearing	8 to 50	35 500 / 49 000	Chapter 3.4.11
		LQCD	LBCD bearing, self-aligning ²⁾	12 to 50	30 000 / 28 000	
		LQCT PA	LPAR, plain bearing	8 to 50	50 800 / 180 000	
	Quadro, open, aluminium housing	LQCT	LBCT bearing	12 to 50	3 500 / 49 000	Chapter 3.4.12
		LQCF	LBCF bearing, self-aligning ²⁾	12 to 50	30 000 / 28 000	
		LQCT PA	LPAT, plain bearing	12 to 50	50 800 / 180 000	

¹⁾ Picture of non D-series bearing or plain bearing differs

²⁾ Automatic compensation of shaft misalignments of up to max. ± 30 minutes of arc (→ [chapter 3.3](#))



Shaft blocks and shaft supports

Picture	Designation	Size	Max load rating dynamic / static	Comments	ISO series	Chapter
-	-	mm	N	-	-	-
	LSCS	8 to 80	-	-	1 / 3	Chapter 3.6.1
	LSHS	12 to 50	-	-	1	Chapter 3.6.2
	LSNS	12 to 50	-	-	3	Chapter 3.6.3
	LEBS A	12 to 50	-	Tandem	1	Chapter 3.6.4
	LEAS ... A/B	8 to 50	-	-	3	Chapter 3.6.5
	LRCB	12 to 80	-	with holes	3	Chapter 3.6.6
	LRCC			without holes		

Precision shafts

Picture	Designation	Size	Max load rating dynamic / static	Comments	ISO series	Chapter
-	-	mm	N	-	-	-
	LJ ...	3 to 80	-	-	1 / 3	Chapter 3.7

Linear slides

Picture	Designation	Size	Max load rating dynamic / static	Comments	ISO series	Chapter
–	–	mm	N		–	
	LZBU ... A	8 to 50	30 000 / 28 000	Quadro A = moving unit B = moving shafts LBCD bearing self-aligning ¹⁾	3	Chapter 3.8.1
	LZBU ... B					Chapter 3.8.2
	LZAU	12 to 50	30 000 / 28 000	Quadro supported shaft LBCF bearing self-aligning ¹⁾	3	Chapter 3.8.3

¹⁾ Automatic compensation of shaft misalignments of up to max. ± 30 minutes of arc (→ **chapter 3.3**)

2

Selection guide



2.1 Technical and calculation data



2.1.1 Permissible operating conditions

The correct functioning of a linear ball bearing guiding system can only be maintained if the principal operating limits are not exceeded. The validity of the rating life calculations depends on the observance of the operating conditions described below.

Dynamic values

Linear ball bearings can reach a maximum speed of $v_{max} = 5$ m/s.

The maximum permissible acceleration is $a_{max} = 100$ m/s².

Permissible operating temperature

The permissible operating temperature range for continuous operation of Ewellix linear ball bearings is from -20 to +80 °C and is determined by the cage and seal materials. Lower and higher temperatures can be tolerated for brief periods.

Friction

Friction in a linear guiding system is affected, apart from the loading, by a number of other factors, notably the type and size of the bearing, the operating speed, as well as the quality and the quantity of lubricant used (↳ **table 1**).

Table 1

Maximum friction force for lubricated D-series bearings, LBCR, LBCD, LBCT and LBCF, each with two seals

Bearing size	Friction forces	
	Running N	Starting N
-		
12	2,5	5
16	3	7
20	4	8
25	5	11
30	7	14
40	8	19

2.1.2 Calculation bases and factors of influence

Static safety factor

The static safety factor is expressed as the relationship between the static load rating and the maximum static bearing load. The static safety factor indicates the level of safety against permanent plastic deformation of the steel balls, raceways and guide shaft and is calculated according to formulae 1 and 2.

$$1) P_0 = \frac{F_{max}}{f_m f_{l0} f_{h0}}$$

$$2) s_0 = \frac{C_0}{P_0}$$

where

- C_0 = basic static load rating [N]
- f_m = factor for misalignment ¹⁾
- f_{l0} = factor for direction of load
- f_{h0} = factor for surface hardness of shaft ¹⁾
- F_{max} = maximum external static load [N]
- P_0 = maximum static load [N]
- s_0 = static safety factor

Depending on the operating conditions, a static safety factor s_0 according to **table 2** is recommended.

Modified basic rating life

If the load situation is known and the factors have been determined, then the equivalent dynamic load and modified basic rating life can be calculated according to the following formulae.

$$3) P = \frac{F}{f_m f_l f_h f_i}$$

Table 2

Recommended static safety (minimum values)

Operating conditions	s_0	
	from	up to
Normal conditions	1	2
Smooth, vibration-free operation	2	4
Shock loads or vibration	3	5

¹⁾ Contact Ewellix for further explanations

$$4) L_{ns} = 100 c_1 c_2 f_s \left(\frac{C}{P}\right)^3$$

where

- L_{ns} = modified basic rating life [km]
- c_1 = factor for reliability
- c_2 = factor for operating conditions
- f_s = factor for stroke length
- f_m = factor for misalignment ¹⁾
- f_l = factor for direction of load
- f_h = factor for surface hardness of shaft ¹⁾
- f_i = factor for the number of loaded bearings per shaft
- C = dynamic load rating [N]
- F = external bearing load [N]
- P = equivalent dynamic load

Requisite reliability

Factor c_1 is used for lifetime calculations where a reliability higher than 90 % is needed. The corresponding values can be found in (→ table 3).

Influence of load direction, factors f_l and f_{l0}

Linear ball bearings and units must be mounted so that the line of action of the load falls within the main load direction which is marked on the end of the cage, see C and C_0 maximum values in the product tables.

If the direction of the load deviates from the optimum, the load ratings must be corrected using the factors f_l and f_{l0} (→ diagram 1, diagram 2 and ¹⁾).

In case the load direction is unknown, the C and C_0 minimum values shown in the product tables do apply.

Diagram 1

Factors f_l and f_{l0} related to the direction of load for LBCR and LBCD linear ball bearings of the D-series

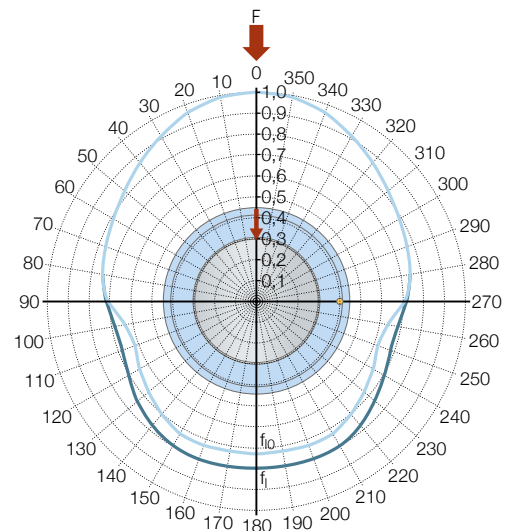

Diagram 2

Factor f_l and f_{l0} related to the direction of load for LBCT and LBCF linear ball bearings of the D-series

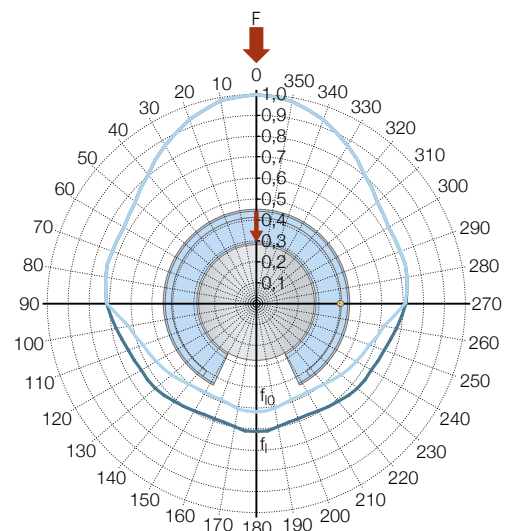

Table 3

Factor c_1 for reliability

Reliability %	L_{ns}	c_1
90	L_{10s}	1
95	L_{5s}	0,62
96	L_{4s}	0,53
97	L_{3s}	0,44
98	L_{2s}	0,33
99	L_{1s}	0,21

¹⁾ Contact Ewellix for further explanations

Operating conditions

The lubrication effectiveness is strongly dependent on the degree of separation between the steel balls and raceway surfaces in the contact zones. A specific minimum viscosity is required for the formation of an effectively separating lubricating film at operating temperature, taking into account the kinematic conditions. Assuming a normal level of cleanliness of the guide shaft as well as effective sealing, factor c_2 depends on the viscosity ratio κ exclusively. κ designates the ratio between the actual kinematic viscosity and the requisite minimum viscosity (↳ **formula 5**)

$$5) \quad \kappa = \frac{u}{u_1}$$

where

- κ = viscosity ratio
- u = actual kinematic viscosity [mm²/s]
- u_1 = requisite minimum viscosity [mm²/s]

The requisite minimum viscosity u_1 in relation to the mean speed and the shaft diameter F_w are shown in **diagram 4**.

Now c_2 can be taken from **diagram 3**. If the viscosity ratio κ is less than 1, a lubricant with extreme pressure (EP) additives is recommended. If lubricants with EP additives are used, the higher value for c_2 can be used for calculation.

Diagram 3
Factor c_2 for operating conditions

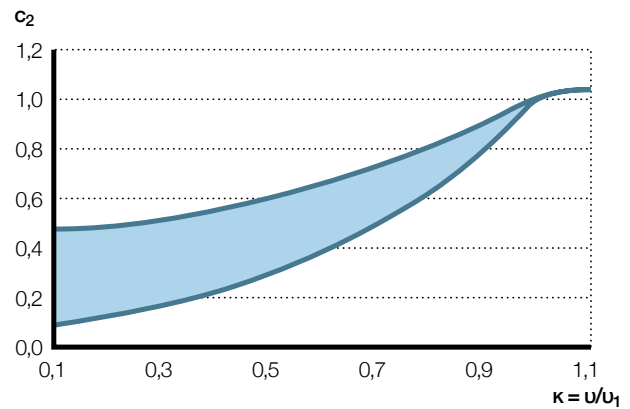
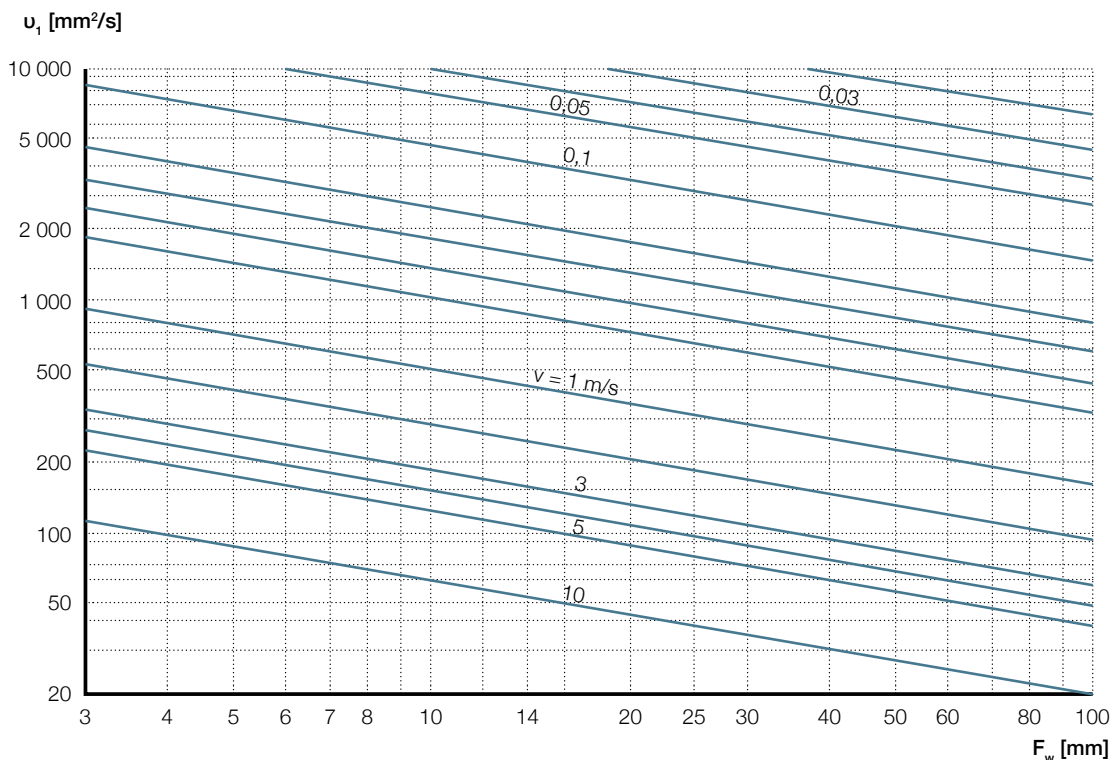

Diagram 4

Requisite kinematic viscosity u_1



Impact of stroke length, factor f_s

Strokes shorter than the raceway length of the linear ball bearing (→ table 4) have a negative influence on the achievable life of a guiding system. Based on the ratio of the single stroke length S relative to raceway length L_2 , factor f_s is determined according to table 5.

Number of loaded bearings per shaft, factor f_i

Most linear ball bearing configurations feature two (or more) bearings mounted on one shaft. The load distribution on these various bearings is strongly influenced by the mounting accuracy, the manufacturing quality of the adjacent components, and in particular, the distance between the bearings. Factor f_i takes these influences on bearing loading into account based on the number of bearings per shaft and the distance between them (→ table 6).

NOTE: This factor has no influence when the bearings are mounted in the same accurate drilling as used in the original housings from Ewellix.

Table 4

Raceway length L_2 of the different linear ball bearing sizes

Type	L_2
LBC. 12 D	18,4
LBC. 16 D	21,2
LBC. 20 D	27,6
LBC. 25 D	37,2
LBC. 30 D	45,4
LBC. 40 D	50,8

Table 5

Factor f_s depending on the ratio S/L_2

S/L_2	f_s
1,0	1,00
0,9	0,91
0,8	0,82
0,7	0,73
0,6	0,63
0,5	0,54
0,4	0,44
0,3	0,34
0,2	0,23
0,1	0,13

Table 6

Factor f_i for number of loaded bearings per shaft

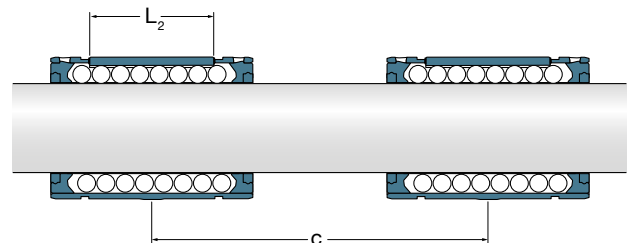

Number of bearings	If $c \geq 1,5 L_2$	If $c < 1,5 L_2$
	f_i	f_i
1	1	1
2	1	0,81
3	1	0,72
99	L_{1s}	0,21

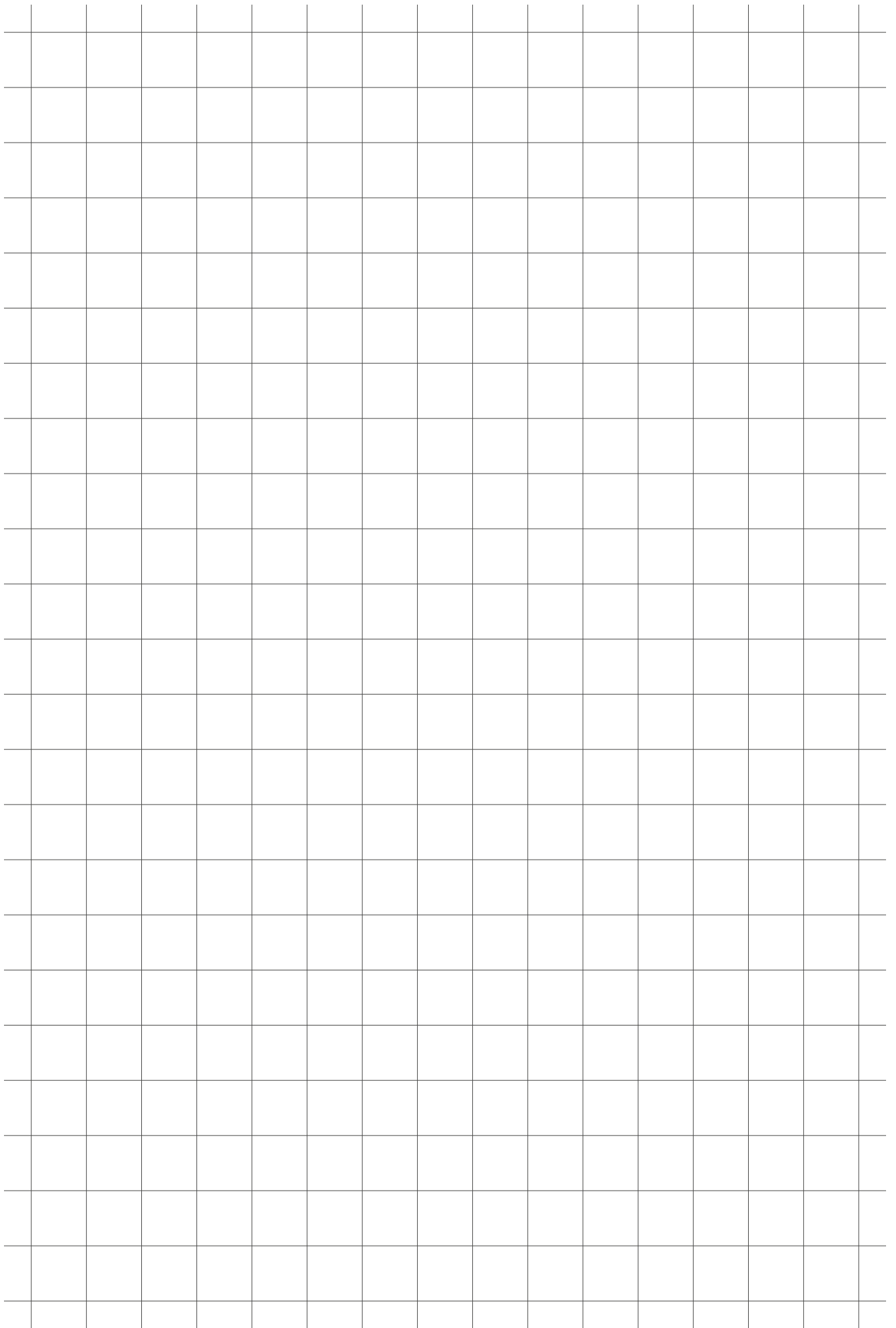

3

Product range



3.1 Compact linear bearings

Linear ball bearings – LBBR

The LBBR linear ball bearing is a unique Ewellix design. The compact bearing is excellent for integration of a linear guide function into other machine parts. It consists of a plastic cage with hardened steel raceways to guide the ball sets. The bearing dimensions are in line with ISO 10285 series 1. The LBBR raceways have been designed to fully utilize the entire length of the loaded zone to increase load ratings and extend bearing rating life. The plastic cage is designed to incorporate optimum functionality and performance. Well-designed ball recirculations offer nearly frictionless and low noise linear guiding function. Sealed variants with integral double lip seals are keeping the lubricant inside the bearing and provide optimum protection for contamination from outside. Sealed bearings in normal environment and applications are lubricated for life and nearly maintenance free. Bearings for nearly frictionless guiding functions are fitted with non-contacting shields to protect the bearing from large particles. The cage itself is providing self-holding function of the bearings in an appropriate housing and under normal conditions. No additional axial fixation of the LBBR bearings is necessary. LBBR bearings are factory pre-lubricated with bearing grease. With suffix HV6, the linear bearings are available with stainless steel balls and raceways for corrosive or harsh environment applications.

Linear plain bearings – LPBR

Ewellix linear plain bearings have the same dimensions as LBBR linear ball bearings. They are made of copolymer polyoxymethylene with a special polyethylene to provide smooth and stick-slip-free operation. Linear plain bearings are self-lubricating under normal conditions and are nearly maintenance free. They have a high static load rating and are resistant to shock loads. Ewellix recommends a light coating of lubricant during installation to improve its performance during the running-in period. LPBR linear plain bearings are intended for high shock loads or shock load applications where motion speed is limited. As LBBR linear bearings, they are self-holding in an appropriate housing.

External shaft seals - SP

Compact linear bearings in very harsh conditions can be equipped with additional external shaft seals to improve lifetime of the bearing. SP seals do have a steel insert covered by rubber material. Shaft seals are also self-holding inside an appropriate housing and require extra housing length to fit in. The high seal lip pressure on the shaft surface is providing excellent functionality against contamination, when friction force is less important.



3.1.1 Compact linear ball bearings - LBBR

- Closed design

- Sizes from 3 mm to 50 mm
- Self-holding in appropriate housing ³⁾
- Factory pre-lubricated with SKF LGEP 2 grease, nearly lubricated for life ⁵⁾
- Available in variants of 2 seals, 2 shields or seal and shield
- Available as bearing steel (standard) or stainless-steel variant
- Clearance or preload determined by shaft and housing bore tolerance



Pictured is LBBR 30-2LS

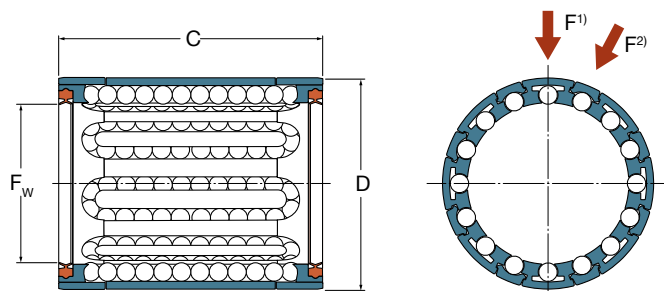

Picture shows LBBR with 2 double lip seals

Dimensions			No. of ball rows
F _w mm	D ³⁾	C	–
3	7	10	4
4	8	12	4
5	10	15	4
6	12	22 ⁴⁾	4
8	15	24	4
10	17	26	5
12	19	28	5
14	21	28	5
16	24	30	5
20	28	30	6
25	35	40	7
30	40	50	8
40	52	60	8
50	62	70	9

¹⁾ Direction for max. static load ratings of all sizes and max. dynamic load ratings of sizes 3 to 20 and 50
²⁾ Direction for max. dynamic load ratings for size 25, 30, 40. For these 3 sizes, the directions of max. static and max. dynamic load ratings differ
³⁾ The linear ball bearing requires no additional axial fixation when fitted into a bore with tolerance J7 or J6
⁴⁾ Width 22 does not correspond to series 1 standards in ISO 10285
⁵⁾ Can be re-lubricated in appropriate housings

LBBR

Designations			Mass	Basic load ratings ¹⁾			
with shields	with 2 double lip seals	with 1 double lip seal		dynamic C	max	static C ₀	max
–			kg	min ²⁾		min ²⁾	
LBBR 3 ³⁾	LBBR 3-2LS ³⁾	LBBR 3-LS ^{3) s)}	0,0007	60	67	44	63
LBBR 4 ³⁾	LBBR 4-2LS ³⁾	LBBR 4-LS ^{3) s)}	0,001	75	85	60	85
LBBR 5 ³⁾	LBBR 5-2LS ³⁾	LBBR 5-LS ^{3) s)}	0,002	170	193	129	183
LBBR 6 A ⁴⁾	LBBR 6 A-2LS ⁴⁾	LBBR 6 A-LS ^{4) s)}	0,006	335	390	270	380
LBBR 8	LBBR 8-2LS	LBBR 8-LS ^{s)}	0,007	490	560	355	500
LBBR 10	LBBR 10-2LS	LBBR 10-LS ^{s)}	0,011	585	695	415	600
LBBR 12	LBBR 12-2LS	LBBR 12-LS ^{s)}	0,012	695	815	510	750
LBBR 14	LBBR 14-2LS	LBBR 14-LS ^{s)}	0,013	710	850	530	765
LBBR 16	LBBR 16-2LS	LBBR 16-LS ^{s)}	0,018	930	1 100	630	915
LBBR 20	LBBR 20-2LS	LBBR 20-LS ^{s)}	0,021	1 160	1 220	800	1 020
LBBR 25	LBBR 25-2LS	LBBR 25-LS ^{s)}	0,047	2 080	2 120	1 560	1 800
LBBR 30	LBBR 30-2LS	LBBR 30-LS ^{s)}	0,07	3 100	3 150	2 700	3 050
LBBR 40	LBBR 40-2LS	LBBR 40-LS ^{s)}	0,13	5 400	5 500	4 500	5 000
LBBR 50	LBBR 50-2LS	LBBR 50-LS ^{s)}	0,18	6 950	7 100	6 300	6 950

LBBR in stainless steel

Designations			Mass	Basic load ratings ¹⁾			
with shields	with 2 double lip seals	with 1 double lip seal		dynamic C	max	static C ₀	max
–			kg	min ²⁾		min ²⁾	
LBBR 3/HV6 ³⁾	LBBR 3-2LS/HV6 ³⁾	LBBR 3-LS/HV6 ^{3) n)}	0,0007	60	67	44	63
LBBR 4/HV6 ³⁾	LBBR 4-2LS/HV6 ³⁾	LBBR 4-LS/HV6 ^{3) n)}	0,001	75	85	60	85
LBBR 5/HV6 ³⁾	LBBR 5-2LS/HV6 ³⁾	LBBR 5-LS/HV6 ^{3) n)}	0,002	170	193	129	183
LBBR 6 A/HV6 ⁴⁾	LBBR 6 A-2LS/HV6 ⁴⁾	LBBR 6 A-LS/HV6 ^{4) n)}	0,006	335	390	270	380
LBBR 8/HV6	LBBR 8-2LS/HV6	LBBR 8-LS/HV6 ⁿ⁾	0,007	490	560	355	500
LBBR 10/HV6	LBBR 10-2LS/HV6	LBBR 10-LS/HV6 ⁿ⁾	0,011	585	695	415	600
LBBR 12/HV6	LBBR 12-2LS/HV6	LBBR 12-LS/HV6 ⁿ⁾	0,012	695	815	510	750
LBBR 14/HV6	LBBR 14-2LS/HV6	LBBR 14-LS/HV6 ⁿ⁾	0,013	710	850	530	765
LBBR 16/HV6	LBBR 16-2LS/HV6	LBBR 16-LS/HV6 ⁿ⁾	0,018	930	1 100	630	915
LBBR 20/HV6	LBBR 20-2LS/HV6	LBBR 20-LS/HV6 ⁿ⁾	0,021	1 160	1 220	800	1020
LBBR 25/HV6	LBBR 25-2LS/HV6	LBBR 25-LS/HV6 ⁿ⁾	0,047	2 080	2 120	1 560	1 800
LBBR 30/HV6	LBBR 30-2LS/HV6	LBBR 30-LS/HV6 ⁿ⁾	0,07	3 100	3 150	2 700	3 050
LBBR 40/HV6	LBBR 40-2LS/HV6	LBBR 40-LS/HV6 ⁿ⁾	0,13	5 400	5 500	4 500	5 000
LBBR 50/HV6	LBBR 50-2LS/HV6	LBBR 50-LS/HV6 ⁿ⁾	0,18	6 950	7 100	6 300	6 950

Items without letter footnote are usually available from stock.

³⁾ Delivery time on request

⁴⁾ Delivery time usually 10 days for max. quantity of 4; larger quantities on request

¹⁾ Basic load ratings are valid for bearing steel and stainless steel variants, they must be reduced with stainless steel shafts only

²⁾ To be used if mounted randomly and the direction of max. load rating and the main load are not aligned

³⁾ Delivered and packaged by 4 preserved bearings, which need lubrication before mounting

⁴⁾ Factory pre-lubricated with lubricant Klueber Paraliq P460

3.1.2 Compact linear plain bearings - LPBR

- Closed design

- Sizes from 12 mm to 50 mm
- Self-holding in appropriate housing ¹⁾
- Self-lubricating material
- Dimensional interchangeable with LBBR linear bearings



Pictured is LPBR 40

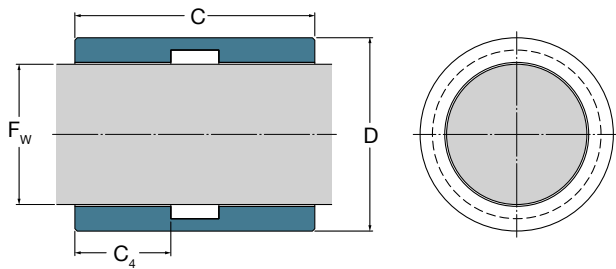

Dimensions			Basic load ratings			Mass	Designations		
F_w	$D^{1)}$	$D_{housing}$	C	C_4	dyn. at 0,1 m/s	4 m/s	stat.	Linear plain bearings	
mm	-0,1				C		C_0		
					N			kg	
12	19,19	19	28	10	965	24	3 350	0,006	LPBR 12 ³⁾
14	21,21	21	28	12	1 340	34	4 750	0,007	LPBR 14 ³⁾
16	24,23	24	30	12	1 530	38	5 400	0,009	LPBR 16 ³⁾
20	28,24	28	30	13	2 080	52	7 350	0,011	LPBR 20 ³⁾
25	35,25	35	40	17	3 400	85	12 000	0,024	LPBR 25 ³⁾
30	40,27	40	50	20	4 800	120	17 000	0,033	LPBR 30 ³⁾
40	52,32	52	60	24	7 650	193	27 000	0,064	LPBR 40 ³⁾
50	62,35	62	70	27	10 800	270	38 000	0,089	LPBR 50 ³⁾

¹⁾ The linear ball bearing requires no additional axial fixation when fitted into a housing with bore diameter $D_{housing}$ in tolerance J7 or J6

³⁾ Delivery time usually 10 days for max. quantity of 4; larger quantities on request

3.1.3 External shaft seals for compact bearings

- Sizes from 6 mm to 50 mm
- Self-holding in appropriate housing
- Request housings with longer length
- Excellent for high contamination environments

Find further details about sealing possibilities in **chapter 4.1.5**.

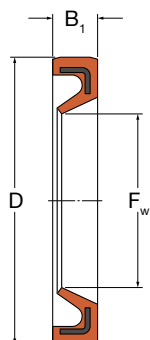

Dimensions			Designations ^{1) 2)}
F _w mm	D	B ₁	–
6	12	2	SP-06x12x02/SEAL
8	15	3	SP-08x15x03/SEAL ⁿ⁾
10	17	3	SP-10x17x03/SEAL
12	19	3	SP-12x19x03/SEAL
14	21	3	SP-14x21x03/SEAL
16	24	3	SP-16x24x03/SEAL
20	28	4	SP-20x28x04/SEAL
25	35	4	SP-25x35x04/SEAL
30	40	4	SP-30x40x04/SEAL
40	52	5	SP-40x52x05/SEAL
50	62	5	SP-50x62x05/SEAL

Items without letter footnote are usually available from stock.

ⁿ⁾ Delivery time on request

¹⁾ Max. speed 3 m/s

²⁾ The designation of the shaft seal in catalogue and on the seal can differ. Eg. SP-10x17x3 (catalogue) and SP-10 17 3-4 (on the seal)

3.2 Compact linear units

The combination of linear bearing and housing is called a unit. The housing defines the outer tolerance of the bearing and is essential for the linear function. Ewellix offers several types of linear bearing units to meet the demand of flexible slide designs in width or length from modular standard products.

Linear bearing units of the compact range consist of a linear bearing and an aluminium housing. These units are extremely compact, cost-effective and lightweight. All linear bearing units are factory pre-lubricated for direct use. Thanks to factory pre-lubrication and the integral double lip seals, these units can operate without relubrication, under normal operating conditions. Therefore, the compact units have no grease fitting for relubrication.

If re-greasing is required by the application, please contact Ewellix for support.

For corrosive or humid environments, Ewellix offers different units with the stainless steel variant of the LBBR bearing. This is identified by a HV6 suffix in the designation, e.g. LUHR 20-2LS/HV6. Additionally, the units are available with plain bearings too.

To complete the linear guiding system, precision shaft and shaft blocks are needed. Please find suitable shaft blocks in **chapter 3.6** and precision shafts in different materials and designs in **chapter 3.7**.

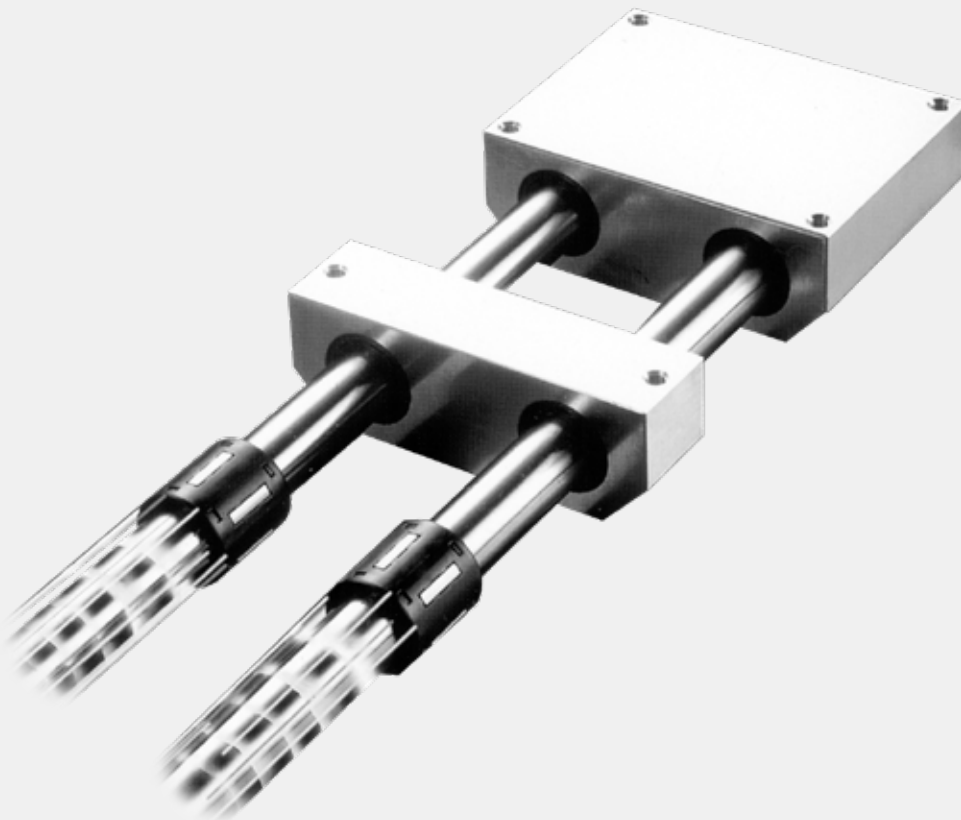

LUHR/LUJR

LUHR and LUJR compact linear units are single units and consist of a closed aluminium housing and a LBBR linear ball bearing, with or without seals. LUJR are of the same design as LUHR but have an extended housing length for two additional external shaft seals for highly contaminated environments. LUHR and LUJR are also available with LPBR linear plain bearings. LUHR/LUJR units can be used to build any flexible design or configuration of compact linear slide systems. They can be bolted from the bottom and top side and are greased for life under normal conditions. Both designs are available for shaft diameters from 12 to 50 mm. Please find suitable shaft blocks in **chapter 3.6**.

LTBR

LTBR compact tandem units consist of two mounted LBBR linear ball bearings in an aluminium housing. The bearings of a tandem unit with designation -2LS have seals towards the outside of the housing. They are also available with LPBR linear plain bearings. LTBR units are particularly suitable for tables or slides of any width and can be bolted from the bottom and top side. They are greased for life under normal conditions. These units are available for shaft diameters ranging from 12 to 50 mm. Please find suitable shaft blocks in **chapter 3.6**.

LTDR

LTDR compact duo units are characterized by a defined shaft distance and contain two parallel LBBR linear ball bearings in an aluminium housing. The bearings can be with or without seals. They are also available with a LPBR linear plain bearing. LTDR units are suitable for slides of flexible length. The space between the two bearings of the duo configuration permits easy fitting of a linear drive. The units can be bolted from the bottom and top side and are greased for life under normal conditions. The units are available for shaft diameters from 12 to 50 mm. Please find suitable shaft blocks in **chapter 3.6**.

LQBR

LQBR compact quadro units contain four LBBR linear ball bearings within an aluminium housing. The bearings of a quadro unit with designation -2LS are sealed towards the outside of the housing. Quadro units can also be equipped with LPBR linear plain bearings. Such a quadro unit is a slide and the space between the bearings permits easy fitting of a linear drive. Quadro linear bearing units are greased for life under normal conditions. The units can be bolted from the bottom and top side. Please find suitable shaft blocks in **chapter 3.6**.

3.2.1 Compact linear units – LUHR

- LUHR with LBBR bearing
- LUHR PB with LPBR linear plain bearing

- Sizes from 12 mm to 50 mm, for flexible slide design
- Aluminium housing covers the entire bearing length
- Pre-lubricated units, greased for life under normal conditions
- Available as sealed or shielded variant for low friction
- Standard or stainless steel linear ball bearings can be chosen
- Units can be bolted from the bottom and top side



Pictured is LUHR 20-2LS ³⁾

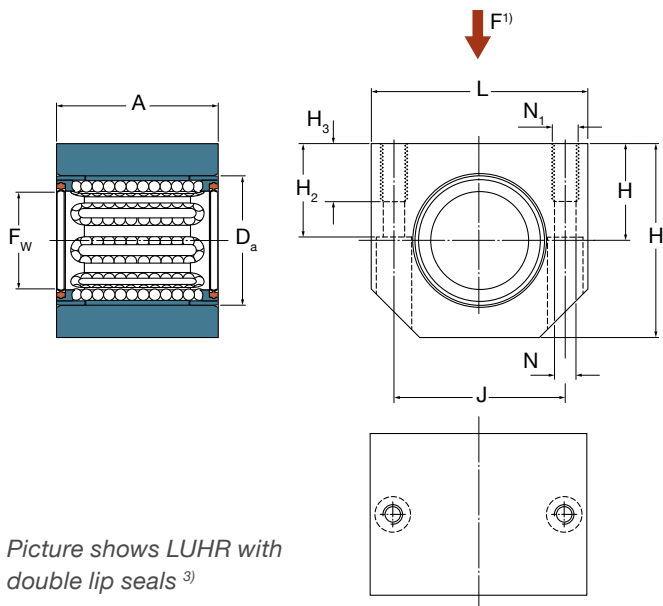

Picture shows LUHR with double lip seals ³⁾

Dimensions

F _w mm	A	D _a	H ±0,01	H ₁	H ₂	H ₃	L	J	N ²⁾	N ₁ -
12	28	19	17	33	16	11	40	29	4,3	M5
16	30	24	19	38	18	11	45	34	4,3	M5
20	30	28	23	45	22	13	53	40	5,3	M6
25	40	35	27	54	26	18	62	48	6,6	M8
30	50	40	30	60	29	18	67	53	6,6	M8
40	60	52	39	76	38	22	87	69	8,4	M10
50	70	62	47	92	46	26	103	82	10,5	M12

¹⁾ Direction for max. load ratings

²⁾ For cylinder head screws with internal hexagon according to ISO 4762

³⁾ Picture with shields or plain bearing differs

LUHR

Designations				Mass kg	Basic load ratings ¹⁾			
LBBR bearing inside with shields		Stainless steel variant of LBBR bearing inside with double lip seals			dynamic C min max		static C ₀ min max	
-		-		N		-		
LUHR 12 ^{s)}	LUHR 12-2LS	LUHR 12/HV6 ⁿ⁾	LUHR 12-2LS/HV6 ⁿ⁾	0,08	695	815	510	750
LUHR 16 ^{s)}	LUHR 16-2LS	LUHR 16/HV6 ⁿ⁾	LUHR 16-2LS/HV6 ⁿ⁾	0,1	930	1 100	630	915
LUHR 20 ^{s)}	LUHR 20-2LS	LUHR 20/HV6 ⁿ⁾	LUHR 20-2LS/HV6 ⁿ⁾	0,14	1 160	1 220	800	1 020
LUHR 25 ^{s)}	LUHR 25-2LS	LUHR 25/HV6 ⁿ⁾	LUHR 25-2LS/HV6 ⁿ⁾	0,25	2 120	2 080	1 560	1 800
LUHR 30 ^{s)}	LUHR 30-2LS	LUHR 30/HV6 ⁿ⁾	LUHR 30-2LS/HV6 ⁿ⁾	0,37	3 150	3 100	2 700	3 050
LUHR 40 ^{s)}	LUHR 40-2LS	LUHR 40/HV6 ⁿ⁾	LUHR 40-2LS/HV6 ⁿ⁾	0,74	5 500	5 400	4 500	5 000
LUHR 50 ^{s)}	LUHR 50-2LS	LUHR 50/HV6 ⁿ⁾	LUHR 50-2LS/HV6 ⁿ⁾	1,19	6 950	7 100	6 300	6 950

LUHR PB

Designations LPBR linear plain bearing inside	Mass kg	Basic load ratings		static ²⁾ C ₀
		dynamic C at 0,1 m/s N	at 4 m/s	
-	-	-	-	-
LUHR 12 PB ^{s)}	0,074	965	24	3 350
LUHR 16 PB ^{s)}	0,091	1 530	38	5 400
LUHR 20 PB ^{s)}	0,130	2 080	52	7 350
LUHR 25 PB ^{s)}	0,227	3 400	85	12 000
LUHR 30 PB ^{s)}	0,333	4 800	120	17 000
LUHR 40 PB ^{s)}	0,674	7 650	193	27 000
LUHR 50 PB ^{s)}	1,099	10 800	270	38 000

Items without letter footnote are usually available from stock.

^{s)} Delivery time on request

ⁿ⁾ Delivery time usually 10 days for max. quantity of 4; larger quantities on request

¹⁾ Basic load ratings are valid for bearing steel and stainless steel variants, they must be reduced with stainless steel shafts only

²⁾ Valid if the loads onto the housing are exclusively in direction of red arrow, see dimensional drawing on left page

3.2.2 Compact linear units – LUJR

- LUJR with LBBR bearing and external shaft seals
- LUJR PB with LPBR linear plain bearing and external shaft seals

- Sizes from 12 mm to 50 mm, for flexible slide design
- Aluminium housing covers bearing and 2 shaft seals
- Pre-lubricated units, greased for life under normal conditions
- Equipped with two external seals for harsh environments
- Available as sealed (double sealed) or shielded variant
- Standard or stainless steel linear ball bearings can be chosen
- Units can be bolted from the bottom and top side



Pictured is LUJR 20 ³⁾

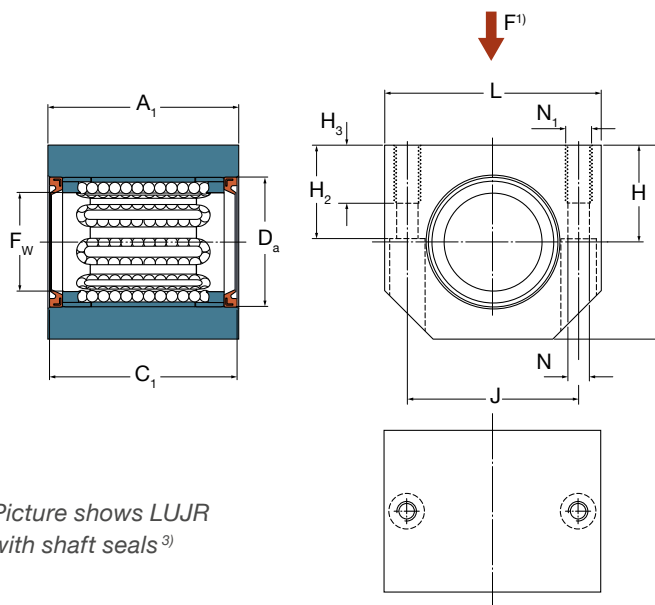

Picture shows LUJR with shaft seals ³⁾

Dimensions											
F _w mm	A ₁	C ₁	D _a	H ±0,01	H ₁	H ₂	H ₃	L	J	N ²⁾	N ₁ –
12	35	34	19	17	33	16	11	40	29	4,3	M5
16	37	36	24	19	38	18	11	45	34	4,3	M5
20	39	38	28	23	45	22	13	53	40	5,3	M6
25	49	48	35	27	54	26	18	62	48	6,6	M8
30	59	58	40	30	60	29	18	67	53	6,6	M8
40	71	70	52	39	76	38	22	87	69	8,4	M10
50	81	80	62	47	92	46	26	103	82	10,5	M12

¹⁾ Direction for max. load ratings

²⁾ For cylinder head screws with internal hexagon according to ISO 4762

³⁾ Picture with double lip seals or plain bearing differs

LUJR ²⁾

Designations				Mass kg	Basic load ratings ¹⁾			
with shields	with double lip seals	with shields	with double lip seals		dynamic C min N	max	static C ₀ min	max
LBBR bearing inside plus shaft seals		Stainless steel variant of LBBR bearing inside plus shaft seals						
–								
LUJR 12	LUJR 12-2LS ⁿ⁾	LUJR 12/HV6 ⁿ⁾	LUJR 12-2LS/HV6 ⁿ⁾	0,10	695	815	510	750
LUJR 16	LUJR 16-2LS ⁿ⁾	LUJR 16/HV6 ⁿ⁾	LUJR 16-2LS/HV6 ⁿ⁾	0,12	930	1 100	630	915
LUJR 20	LUJR 20-2LS ⁿ⁾	LUJR 20/HV6 ⁿ⁾	LUJR 20-2LS/HV6 ⁿ⁾	0,18	1 160	1 220	800	1 020
LUJR 25	LUJR 25-2LS ⁿ⁾	LUJR 25/HV6 ⁿ⁾	LUJR 25-2LS/HV6 ⁿ⁾	0,30	2 120	2 080	1 560	1 800
LUJR 30	LUJR 30-2LS ⁿ⁾	LUJR 30/HV6 ⁿ⁾	LUJR 30-2LS/HV6 ⁿ⁾	0,44	3 150	3 100	2 700	3 050
LUJR 40	LUJR 40-2LS ⁿ⁾	LUJR 40/HV6 ⁿ⁾	LUJR 40-2LS/HV6 ⁿ⁾	0,86	5 500	5 400	4 500	5 000
LUJR 50	LUJR 50-2LS ⁿ⁾	LUJR 50/HV6 ⁿ⁾	LUJR 50-2LS/HV6 ⁿ⁾	1,37	6 950	7 100	6 300	6 950

LUJR PB ²⁾

Designations	Mass kg	Basic load ratings		static ³⁾ C ₀
LPBR linear plain bearing inside plus shaft seals		dynamic C at 0,1 m/s N	at 4 m/s	
–				
LUHR 12 PB ⁿ⁾	0,074	965	24	3 350
LUHR 16 PB ⁿ⁾	0,091	1 530	38	5 400
LUHR 20 PB ⁿ⁾	0,130	2 080	52	7 350
LUHR 25 PB ⁿ⁾	0,227	3 400	85	12 000
LUHR 30 PB ⁿ⁾	0,333	4 800	120	17 000
LUHR 40 PB ⁿ⁾	0,674	7 650	193	27 000
LUHR 50 PB ⁿ⁾	1,099	10 800	270	38 000

Items without letter footnote are usually available from stock.

ⁿ⁾ Delivery time on request

^{o)} Delivery time usually 10 days for max. quantity of 4; larger quantities on request

¹⁾ Basic load ratings are valid for bearing steel and stainless steel variants, they must be reduced with stainless steel shafts only

²⁾ Max. speed 3 m/s

³⁾ Valid if the loads onto the housing are exclusively in direction of red arrow, see dimensional drawing on left page

3.2.3 Compact tandem units - LTBR

- LTBR with LBBR bearings
- LTBR PB with LPBR linear plain bearings

- Sizes from 12 mm to 50 mm for flexible slide width
- Aluminium housing with 2 mounted bearings
- Pre-lubricated units, greased for life under normal conditions
- Available as sealed or shielded variant for low friction
- Standard or stainless steel linear ball bearings can be chosen
- Units can be bolted from the bottom and top side



Pictured is LTBR 20-2LS ³⁾

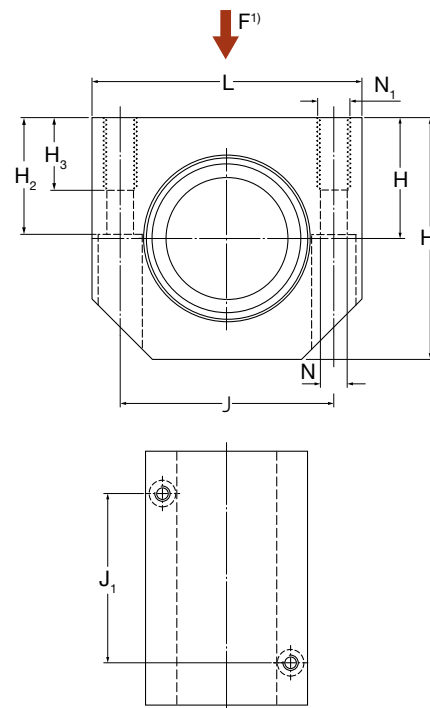
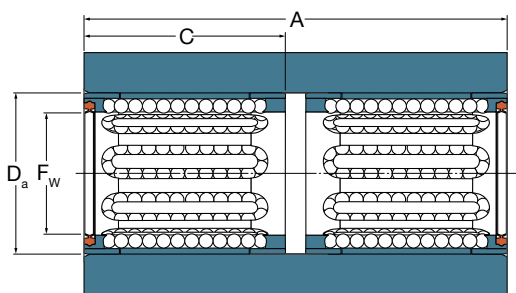

Picture shows LTBR with double lip seals on the outside ³⁾

Dimensions												
F_w	A	C	D_a	H $\pm 0,01$	H_1	H_2	H_3	J	J_1	L	$N^{2)}$	N_1
mm												-
12	60	28	19	17	33	16	11	29	35	40	4,3	M5
16	65	30	24	19	38	18	11	34	40	45	4,3	M5
20	65	30	28	23	45	22	13	40	45	53	5,3	M6
25	85	40	35	27	54	26	18	48	55	62	6,6	M8
30	105	50	40	30	60	29	18	53	70	67	6,6	M8
40	125	60	52	39	76	38	22	69	85	87	8,4	M10
50	145	70	62	47	92	46	26	82	100	103	10,5	M12

¹⁾ Direction for max. load ratings

²⁾ For 2 cylinder head screws with internal hexagon according to ISO 4762

³⁾ Picture with shields or plain bearing differs

LTBR

Designations			Mass	Basic load ratings ¹⁾			
LBBR bearing inside with shields	with double lip seals	Stainless steel variant of LBBR bearing inside with double lip seals		dynamic C		static C ₀	
–			kg	min	max	min	max
LTBR 12 ^{s)}	LTBR 12-2LS ^{s)}	LTBR 12-2LS/HV6 ⁿ⁾	0,17	1 140	1 340	1 020	1 500
LTBR 16 ^{s)}	LTBR 16-2LS ^{s)}	LTBR 16-2LS/HV6 ⁿ⁾	0,22	1 530	1 800	1 270	1 830
LTBR 20 ^{s)}	LTBR 20-2LS ^{s)}	LTBR 20-2LS/HV6 ⁿ⁾	0,31	1 900	2 000	1 600	2 040
LTBR 25 ^{s)}	LTBR 25-2LS ^{s)}	LTBR 25-2LS/HV6 ⁿ⁾	0,54	3 400	3 450	3 150	3 600
LTBR 30 ^{s)}	LTBR 30-2LS ^{s)}	LTBR 30-2LS/HV6 ⁿ⁾	0,80	5 100	5 200	5 400	6 100
LTBR 40 ^{s)}	LTBR 40-2LS ^{s)}	LTBR 40-2LS/HV6 ⁿ⁾	1,57	8 800	9 000	9 000	10 000
LTBR 50 ^{s)}	LTBR 50-2LS ^{s)}	LTBR 50-2LS/HV6 ⁿ⁾	2,51	11 400	11 600	12 700	14 000

LTBR PB

Designations	Mass	Basic load ratings		static ²⁾ C ₀
		dynamic C at 0,1 m/s N	at 4 m/s	
–	kg			
LTBR 12 PB ⁿ⁾	0,16	1 930	48	6 700
LTBR 16 PB ⁿ⁾	0,21	3 060	76	10 800
LTBR 20 PB ⁿ⁾	0,29	4 160	104	14 700
LTBR 25 PB ⁿ⁾	0,52	6 800	170	24 000
LTBR 30 PB ⁿ⁾	0,75	9 600	240	34 000
LTBR 40 PB ⁿ⁾	1,50	15 300	386	54 000
LTBR 50 PB ⁿ⁾	2,38	21 600	540	76 000

ⁿ⁾ Delivery time on request

^{s)} Delivery time usually 10 days for max. quantity of 4; larger quantities on request

¹⁾ Basic load ratings are valid for bearing steel and stainless steel variants, they must be reduced with stainless steel shafts only

²⁾ Valid if the loads onto the housing are exclusively in direction of red arrow, see dimensional drawing on left page

3.2.4 Compact duo units - LTDR

- LTDR with LBBR bearings
- LTDR PB with LPBR linear plain bearings

- Sizes from 12 mm to 50 mm, for flexible slide length
- Aluminium housing with 2 mounted bearings
- Pre-lubricated units, greased for life under normal conditions
- Available as sealed or shielded variant for low friction
- Standard or stainless steel linear ball bearings can be chosen
- Units can be bolted from the bottom and top side



Pictured is LTDR 20-2LS ³⁾

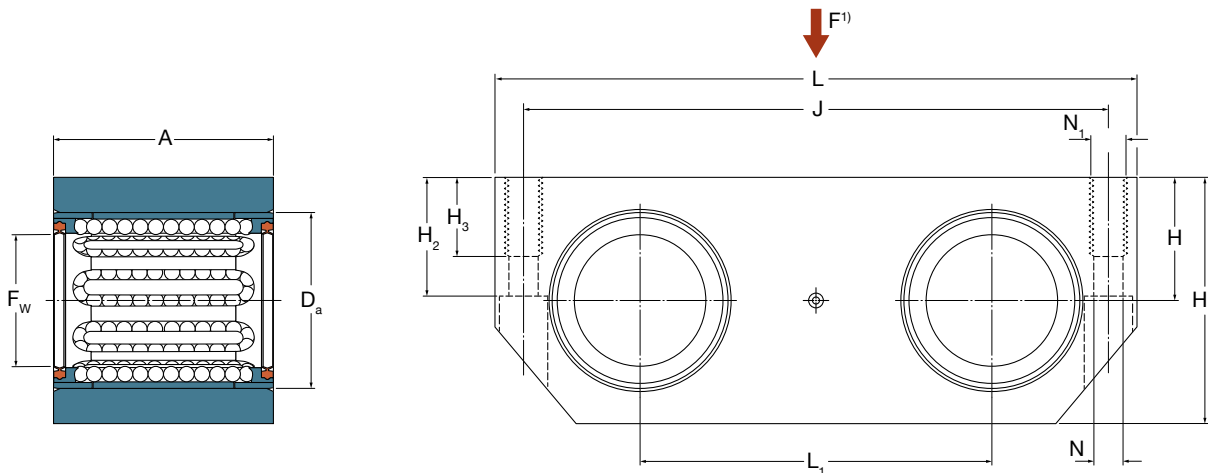

Picture shows LTDR with double lip seals ³⁾

Dimensions											
F_w	A	D_a	H $\pm 0,01$	H_1	H_2	H_3	J	L	L_1	$N^{2)}$	N_1
mm											-
12	28	19	15	30	14	11	69	80	40	4,3	M5
16	30	24	17,5	35	16,5	11	86	96	52	4,3	M5
20	30	28	20	40	19	13	103	115	63	5,3	M6
25	40	35	25	50	24	18	123	136	75	6,6	M8
30	50	40	28	56	27	18	133	146	80	6,6	M8
40	60	52	35	70	34	22	166	184	97	8,4	M10
50	70	62	40	80	39	26	189	210	107	11	M12

¹⁾ Direction for max. load ratings

²⁾ For 2 cylinder head screws with internal hexagon to ISO 4762 at the centre (0,5 A) of the linear bearing unit

³⁾ Picture with shields or plain bearing differs

LTDR

Designations			Mass kg	Basic load ratings ¹⁾			
LBBR bearing inside with shields	with double lip seals	Stainless steel variant of LBBR bearing inside with double lip seals		dynamic C		static C ₀	
-				min	max	min	max
LTDR 12 ⁿ⁾	LTDR 12-2LS ^{s)}	LTDR 12-2LS/HV6 ⁿ⁾	0,15	1 140	1 340	1 020	1 500
LTDR 16 ⁿ⁾	LTDR 16-2LS ^{s)}	LTDR 16-2LS/HV6 ⁿ⁾	0,22	1 530	1 800	1 270	1 830
LTDR 20 ⁿ⁾	LTDR 20-2LS ^{s)}	LTDR 20-2LS/HV6 ⁿ⁾	0,30	1 900	2 000	1 600	2 040
LTDR 25 ⁿ⁾	LTDR 25-2LS ^{s)}	LTDR 25-2LS/HV6 ⁿ⁾	0,58	3 400	3 450	3 150	3 600
LTDR 30 ⁿ⁾	LTDR 30-2LS ^{s)}	LTDR 30-2LS/HV6 ⁿ⁾	0,85	5 100	5 200	5 400	6 100
LTDR 40 ⁿ⁾	LTDR 40-2LS ^{s)}	LTDR 40-2LS/HV6 ⁿ⁾	1,56	8 800	9 000	9 000	10 000
LTDR 50 ⁿ⁾	LTDR 50-2LS ^{s)}	LTDR 50-2LS/HV6 ⁿ⁾	2,21	11 400	11 600	12 700	14 000

LTDR PB

Designations	Mass kg	Basic load ratings		static ²⁾ C ₀
		dynamic C at 0,1 m/s N	at 4 m/s	
LPBR linear plain bearing inside				
-				
LTDR 12 PB ⁿ⁾	0,14	1 930	48	6 700
LTDR 16 PB ⁿ⁾	0,21	30 60	76	10 800
LTDR 20 PB ⁿ⁾	0,28	4 160	104	14 700
LTDR 25 PB ⁿ⁾	0,56	6 800	170	24 000
LTDR 30 PB ⁿ⁾	0,80	9 600	240	34 000
LTDR 40 PB ⁿ⁾	1,49	15 300	386	54 000
LTDR 50 PB ⁿ⁾	2,08	21 600	540	76 000

ⁿ⁾ Delivery time on request

^{s)} Delivery time usually 10 days for max. quantity of 4; larger quantities on request

¹⁾ Basic load ratings are valid for bearing steel and stainless steel variants, they must be reduced with stainless steel shafts only

²⁾ Valid if the loads onto the housing are exclusively in direction of red arrow, see dimensional drawing on left page

3.2.5 Compact quadro units - LQBR

- LQBR with LBBR bearings
- LQBR PB with LPBR linear plain bearings

- Sizes from 12 mm to 50 mm, a compact slide ready to use
- Aluminium housing with 4 mounted bearings
- Pre-lubricated units, greased for life under normal conditions
- Available as sealed or shielded variant for low friction
- Standard or stainless steel linear ball bearings can be chosen
- Units can be bolted from the bottom and top side



Pictured is LQBR 20-2LS ³⁾

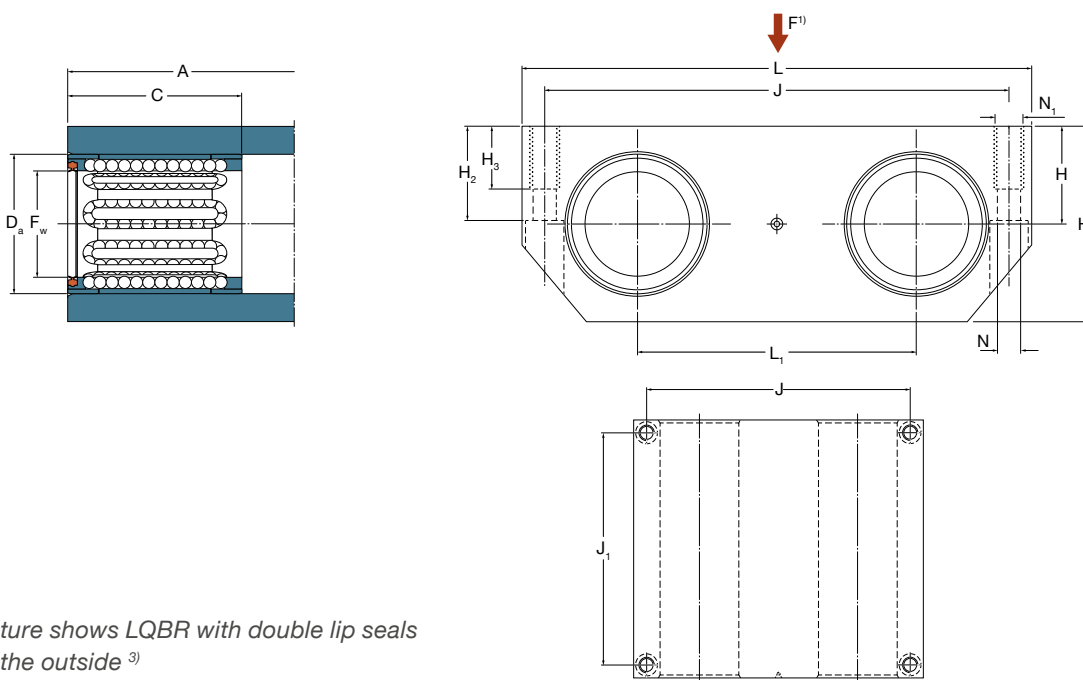

Picture shows LQBR with double lip seals on the outside ³⁾

Dimensions													
F_w	A	C	D_a	$H \pm 0,01$	H_1	H_2	H_3	J	J_1	L	L_1	$N^{2)}$	N_1
mm													-
12	70	28	19	15	30	14	11	69	59	80	40	4,3	M5
16	80	30	24	17,5	35	16,5	11	86	70	96	52	4,3	M5
20	85	30	28	20	40	19	13	103	73	115	63	5,3	M6
25	100	40	35	25	50	24	18	123	87	136	75	6,6	M8
30	130	50	40	28	56	27	18	133	117	146	80	6,6	M8
40	150	60	52	35	70	34	22	166	132	184	97	8,4	M10
50	175	70	62	40	80	39	26	189	154	210	107	10,5	M12

¹⁾ Direction for max. load ratings

²⁾ For 4 cylinder head screws with internal hexagon according to ISO 4762

³⁾ Picture with shields or plain bearing differs

LQBR

Designations			Mass	Basic load ratings ¹⁾			
LBBR bearing inside with shields	with double lip seals	Stainless steel variant of LBBR bearing inside with double lip seals		dynamic C		static C ₀	
–			kg	min	max	min	max
LQBR 12 ⁿ⁾	LQBR 12-2LS ^{s)}	LQBR 12-2LS/HV6 ⁿ⁾	0,38	1 860	2 160	2 040	3 000
LQBR 16 ⁿ⁾	LQBR 16-2LS ^{s)}	LQBR 16-2LS/HV6 ⁿ⁾	0,57	2 500	2 900	2 550	3 650
LQBR 20 ⁿ⁾	LQBR 20-2LS ^{s)}	LQBR 20-2LS/HV6 ⁿ⁾	0,82	3 100	3 250	3 200	4 150
LQBR 25 ⁿ⁾	LQBR 25-2LS ^{s)}	LQBR 25-2LS/HV6 ⁿ⁾	1,43	5 500	5 600	6 300	7 200
LQBR 30 ⁿ⁾	LQBR 30-2LS ^{s)}	LQBR 30-2LS/HV6 ⁿ⁾	2,15	8 300	8 500	10 800	12 200
LQBR 40 ⁿ⁾	LQBR 40-2LS ^{s)}	LQBR 40-2LS/HV6 ⁿ⁾	3,83	14 300	14 600	18 000	20 000
LQBR 50 ⁿ⁾	LQBR 50-2LS ^{s)}	LQBR 50-2LS/HV6 ⁿ⁾	5,40	18 600	19 000	25 500	28 000

LQBR PB

Designations	Mass	Basic load ratings		static ²⁾ C ₀
		dynamic C at 0,1 m/s N	at 4 m/s	
LPBR linear plain bearing inside				
–	kg			
LQBR 12 PB ⁿ⁾	0,36	3 860	96	13 400
LQBR 16 PB ⁿ⁾	0,55	6 120	152	21 600
LQBR 20 PB ⁿ⁾	0,78	8 320	208	29 400
LQBR 25 PB ⁿ⁾	1,39	13 600	340	48 000
LQBR 30 PB ⁿ⁾	2,06	19 200	480	68 000
LQBR 40 PB ⁿ⁾	3,68	30 600	772	108 000
LQBR 50 PB ⁿ⁾	5,14	43 200	1 080	152 000

ⁿ⁾ Delivery time on request

^{s)} Delivery time usually 10 days for max. quantity of 4; larger quantities on request

¹⁾ Basic load ratings are valid for bearing steel and stainless steel variants, they must be reduced with stainless steel shafts only

²⁾ Valid if the loads onto the housing are exclusively in direction of red arrow, see dimensional drawing on left page

3.3 Standard linear ball bearings

Linear ball bearings - LBC

Standard linear ball bearings type LBC are well established in the market and the best choice for a variety of applications. High load ratings combined with silent and smooth motion behaviour is provided by this high quality product. The range from diameter 5 mm to 80 mm is in line with the ISO 10285 series 3 dimensions.

LBC bearings consist of a plastic cage with hardened steel raceways, balls and seals. The cage design and ball recirculation is optimised for low noise and nearly no maintenance. Our enormous experience in raceway technology is utilised for these linear ball bearings resulting in outstanding performance.

All Ewellix LBC bearings are available with double lip seals or with non-contacting shields. By using suffix -LS, the bearing is equipped with one shield and one seal on the right hand side of the bearing (→ fig. 1).

The linear bearings are factory pre-lubricated and the sizes from 12 mm to 80 mm do have a lubrication port to regrease directly into the bearings. Ewellix grease fittings have double functionality and are used as axial as well as rotational fixation for the bearing inside the housing, which is mandatory. Please find additional information about fixation in **chapter 3.3.7** and **4.1.4**.

Different sizes do have different designs, to cover the whole range of LBC bearings. For each diameter from 5 mm to 80 mm, Ewellix offers the bearings either in the A-type (black) design or the D-type design (blue). Linear ball bearings of the D-design do have a "D" after the size in the designation, e.g. LBCD 16D-2LS. For harsh environments each LBC bearing is also available as a stainless steel variant identified by suffix /HV6 in the designation.

Open type linear ball bearings - LBC

Ewellix offers closed bearings for unsupported shafts and open bearings for supported shafts. Supported shaft solutions are used for long linear travel distances where shaft bending of closed designs would be too high. LBC bearings from size 12 to 80 mm in open design are available with shields or seals and additionally are equipped with a longitudinal gap seal along the shaft sides. For longest life or demanding load applications, a heavy duty type bearing named LBHT is expanding the range. The LBHT bearing is equipped with the maximum number of raceways to reach the highest load rating per size.

Self aligning linear ball bearings - LBC

The open and closed types both are available with the self-aligning feature. Inaccurate machining of the mounting Surfaces, misaligned shafts, or high load shaft bending can lead to internal stresses when the bearing system is bolted. For such applications, the use of a self-aligning linear ball bearing is recommended.

These bearings do have a special raceway profile. A spherical elevation is ground in the centre of the raceway, which allows tilting of the whole bearing up to an angle of ±30 minutes of arc. Self-aligning bearings can significantly reduce stress and noise in many applications. The result is less peak loads and finally an extended bearing life at lower maintenance cost.

In order to ensure proper sealing functionality of the linear bearing, the outside diameter of the cage is reduced slightly. That allows the entire bearing including the seals to follow the tilting position exactly concentric around the shaft. Ewellix self-aligning bearings have proven good sealing and low friction performance in many applications. (→ fig. 2).

Linear plain bearings - LPA

Ewellix linear plain bearings are interchangeable with LBC linear ball bearings in closed and open design. They are made from special polyethylene plastic to provide smooth and stick-slip-free operation. Linear plain bearings are self-lubricating under normal conditions and are nearly maintenance free. They are used in high static load or shock load applications. Ewellix recommends a light lubrication during installation to improve the performance when running-in. LPA linear plain bearings must be fixed in appropriate housings.

Fig. 1

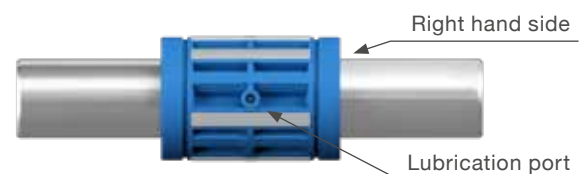
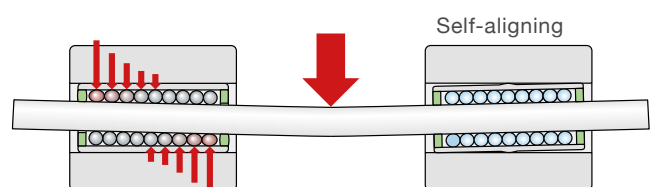

Fig. 2



LBCR

LBCR standard linear ball bearings with their optimized raceway length and the precisely shaped osculation are made for high loads. The straight design of the raceway plate is best for rigid linear bearing applications. The available variants and sizes from 5mm to 80 mm make it suitable for nearly every linear slide solution.

The operating clearance is determined by the housing and the shaft tolerance. When mounted into a slotted housing, the clearance can be adjusted to the needs of the machine. LBCR linear ball bearings must be fixed in axial direction either via the Ewellix grease fittings or retaining rings according to DIN 471.

LBCD - self-aligning

LBCD is the self-aligning type of the closed LBCR standard linear bearing. The self-aligning raceway plate allows bearing adjustments of maximum ± 30 minutes of arc. During a self-aligning process, the bearing seal always stays in optimum contact with the shaft. The LBCD is best for applications which require silent linear motion and smooth running performance. Ewellix offers them from size 12 mm to 50 mm.

Same as with LBCR bearings, the operating clearance is determined by the housing and the shaft tolerance while it can be adjusted in slotted housings towards the machine's needs. LBCD linear ball bearings must be fixed in axial direction either via the Ewellix grease fittings or retaining rings according to DIN 471.

LBCT / LBHT

LBCT and LBHT are open type standard linear ball bearings used for supported shaft solutions. They are best for long linear travel distance applications, where the shaft bending on closed types has its limitations. The straight raceway plates support solutions requiring high rigidity. The LBCT type is available from size 12 mm to 80 mm, where the heavy duty type LBHT is from size 20 mm to 50 mm. The LBHT linear ball bearing is equipped with the maximum number of raceways and is perfect for the highest loads. Both bearing types have a gap seal along the shaft side to avoid contamination.

In appropriate housings, like Ewellix housing LHCT, the clearance can be adjusted. Open type LBCT/LBHT linear ball bearings must be fixed to prevent axial and radial moves inside the housing.

LBCF - self-aligning

LBCF is the self-aligning variant of the open LBCT type. With the possible bearing adjustment of maximum ± 30 minutes of arc, it is best for silent linear motion and smooth running performance. With supported shafts, nearly unlimited stroke of linear slides is possible. The LBCF type is available from size 12 mm to 50 mm.

In appropriate housings, like Ewellix housing LHCT, the clearance can be adjusted. Open type LBCF linear ball bearings must be fixed to prevent axial and radial moves inside the housing. The fixation can be easily done with Ewellix grease fittings. For more information on grease fittings, please have a look at **chapter 3.3.7**.

Standard linear ball bearings - LBCR

- Closed design

- Sizes from 5 mm to 80 mm
- Straight raceway design to support high loads
- Available in variants of 2 seals, 2 shields or seal and shield
- Available as bearing steel (standard) or stainless steel variant
- Factory pre-lubricated with SKF LGEP 2 grease, ready for use
- Clearance or preload determined by shaft and housing bore tolerance, in slotted housings adjustable
- Suitable grease fittings for axial fixation are in **chapter 3.3.7**

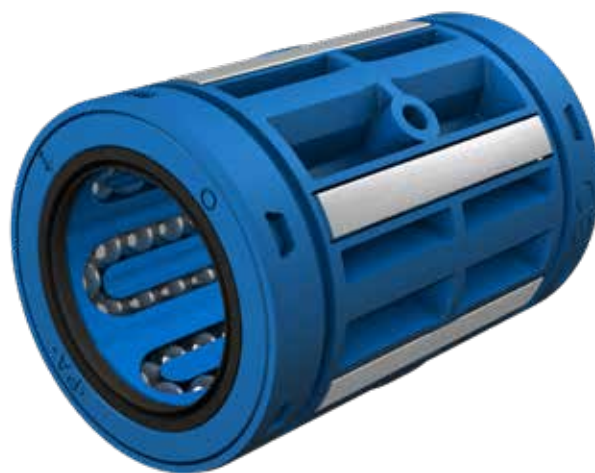

Pictured is LBCR 30 D-2LS ²⁾

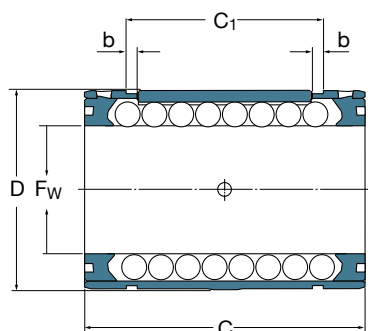

Picture shows LBCR D with shields ²⁾

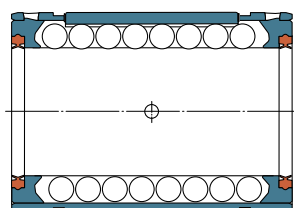

Picture shows LBCR D with 2 double lip seals ²⁾

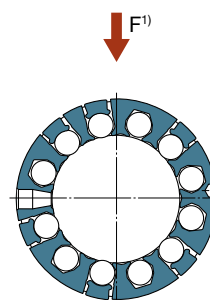

Dimensions					No. of ball rows
F _w mm	D	C	C ₁	b	-
5	12	22	14,2	1,1	4
8	16	25	16,2	1,1	4
12	22	32	22,6	1,3	5
16	26	36	24,6	1,3	5
20	32	45	31,2	1,6	6
25	40	58	43,7	1,85	6
30	47	68	51,7	1,85	6
40	62	80	60,3	2,15	6
50	75	100	77,3	2,65	7
60	90	125	101,3	3,15	7
80	120	165	133,3	4,15	7

¹⁾ Direction for max. load ratings

²⁾ Picture of non D-series bearing differs

LBCR

Designations			Mass	Basic load ratings ¹⁾			
with shields	with 2 double lip seals	with 1 double lip seal		dynamic C	max	static C ₀	max
–			kg	min ²⁾		min ²⁾	
LBCR 5 ^{3) 4)}	LBCR 5-2LS ^{3) 4)}	–	0,005	280	320	210	300
LBCR 8 ⁴⁾	LBCR 8-2LS ⁴⁾	LBCR 8-LS ^{4) s)}	0,009	490	570	355	500
LBCR 12 D	LBCR 12 D-2LS	LBCR 12 D-LS ^{s)}	0,02	930	1 370	695	1 120
LBCR 16 D	LBCR 16 D-2LS	LBCR 16 D-LS ^{s)}	0,026	1 080	1 600	800	1 290
LBCR 20 D	LBCR 20 D-2LS	LBCR 20 D-LS ^{s)}	0,056	2 200	3 250	1 630	2 650
LBCR 25 D	LBCR 25 D-2LS	LBCR 25 D-LS ^{s)}	0,108	3 100	4 550	2 360	3 800
LBCR 30 D	LBCR 30 D-2LS	LBCR 30 D-LS ^{s)}	0,168	4 800	7 100	3 550	5 700
LBCR 40 D	LBCR 40 D-2LS	LBCR 40 D-LS ^{s)}	0,323	7 650	11 200	5 100	8 300
LBCR 50 A	LBCR 50 A-2LS	LBCR 50 A-LS ^{s)}	0,46	9 650	13 400	7 200	12 200
LBCR 60 A	LBCR 60 A-2LS	LBCR 60 A-LS ^{s)}	0,82	14 600	20 400	11 200	18 000
LBCR 80 A	LBCR 80 A-2LS	LBCR 80 A-LS ^{s)}	1,9	26 500	37 500	19 600	32 000

LBCR in stainless steel

Designations			Mass	Basic load ratings ¹⁾			
with shields	with 2 double lip seals	with 1 double lip seal		dynamic C	max	static C ₀	max
–			kg	min ²⁾		min ²⁾	
LBCR 5/HV6 ^{3) 4) n)}	LBCR 5-2LS/HV6 ^{3) 4) s)}	–	0,005	280	320	210	300
LBCR 8/HV6 ^{4) n)}	LBCR 8-2LS/HV6 ^{4) s)}	LBCR 8-LS/HV6 ^{4) n)}	0,009	490	570	355	500
LBCR 12 D/HV6 ⁿ⁾	LBCR 12 D-2LS/HV6 ^{s)}	LBCR 12 D-LS/HV6 ⁿ⁾	0,02	930	1 370	695	1 120
LBCR 16 D/HV6 ⁿ⁾	LBCR 16 D-2LS/HV6 ^{s)}	LBCR 16 D-LS/HV6 ⁿ⁾	0,026	1 080	1 600	800	1 290
LBCR 20 D/HV6 ⁿ⁾	LBCR 20 D-2LS/HV6 ^{s)}	LBCR 20 D-LS/HV6 ⁿ⁾	0,056	2 200	3 250	1 630	2 650
LBCR 25 D/HV6 ⁿ⁾	LBCR 25 D-2LS/HV6 ^{s)}	LBCR 25 D-LS/HV6 ⁿ⁾	0,108	3 100	4 550	2 360	3 800
LBCR 30 D/HV6 ⁿ⁾	LBCR 30 D-2LS/HV6 ^{s)}	LBCR 30 D-LS/HV6 ⁿ⁾	0,168	4 800	7 100	3 550	5 700
LBCR 40 D/HV6 ⁿ⁾	LBCR 40 D-2LS/HV6 ^{s)}	LBCR 40 D-LS/HV6 ⁿ⁾	0,323	7 650	11 200	5 100	8 300
LBCR 50 A/HV6 ⁿ⁾	LBCR 50 A-2LS/HV6 ^{s)}	LBCR 50 A-LS/HV6 ⁿ⁾	0,46	9 650	13 400	7 200	12 200
LBCR 60 A/HV6 ⁿ⁾	LBCR 60 A-2LS/HV6 ^{s)}	LBCR 60 A-LS/HV6 ⁿ⁾	0,82	14 600	20 400	11 200	18 000
LBCR 80 A/HV6 ⁿ⁾	LBCR 80 A-2LS/HV6 ^{s)}	LBCR 80 A-LS/HV6 ⁿ⁾	1,9	26 500	37 500	19 600	32 000

Items without letter footnote are usually available from stock.

ⁿ⁾ Delivery time on request

^{s)} Delivery time usually 10 days for max. quantity of 4; larger quantities on request

¹⁾ Basic load ratings are valid for bearing steel and stainless steel variants, they must be reduced with stainless steel shafts only

²⁾ To be used if mounted randomly and the direction of max. load rating and the main load are not aligned

³⁾ Factory pre-lubricated with lubricant Klueber Paraliq P460

⁴⁾ Linear ball bearings LBCR 5 and LBCR 8 are without fixation hole

3.3.1 Standard linear ball bearings - LBCD

- Closed design, self-aligning

- Sizes from 12 mm to 50 mm
- Possible tilting angle of ± 30 minutes of arc (self-aligning)
- Available in variants of 2 seals, 2 shields or seal and shield
- Available as bearing steel (standard) or stainless steel variant
- Factory pre-lubricated with SKF LGEP 2 grease, ready for use
- Clearance or preload determined by shaft and housing bore tolerance, in slotted housings adjustable
- Suitable grease fittings for axial fixation are in **chapter 3.3.7**

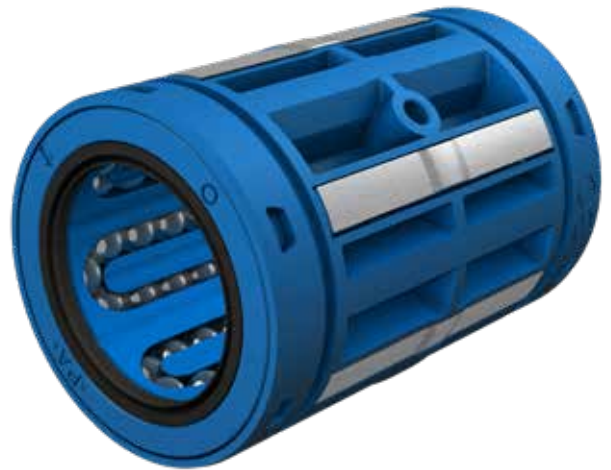

Pictured is LBCD 30 D-2LS ²⁾

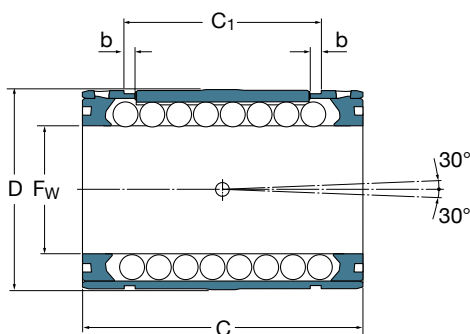

Picture shows LBCD D with shields ²⁾

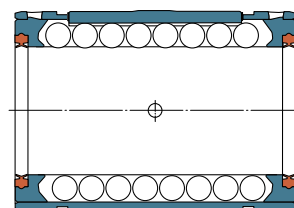

Picture shows LBCD D with 2 double lip seals ²⁾

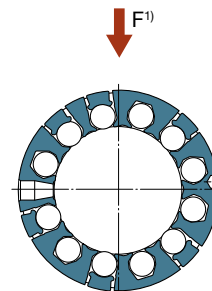

Dimensions						No. of ball rows
F_w mm	D	C	C_1	b		-
12	22	32	22,6	1,3		5
16	26	36	24,6	1,3		5
20	32	45	31,2	1,6		6
25	40	58	43,7	1,85		6
30	47	68	51,7	1,85		6
40	62	80	60,3	2,15		6
50	75	100	77,3	2,65		7

¹⁾ Direction for max. load ratings

²⁾ Picture of non D-series bearing differs

LBCD

Designations			Mass	Basic load ratings ¹⁾			
with shields	with 2 double lip seals	with 1 double lip seal		dynamic C min ²⁾	max	static C ₀ min ²⁾	max
–			kg	N			
LBCD 12 D	LBCD 12 D-2LS	LBCD 12 D-LS ^{s)}	0,02	800	1 220	570	930
LBCD 16 D	LBCD 16 D-2LS	LBCD 16 D-LS ^{s)}	0,025	950	1 400	655	1 060
LBCD 20 D	LBCD 20 D-2LS	LBCD 20 D-LS ^{s)}	0,055	1 730	2 550	1 120	1 800
LBCD 25 D	LBCD 25 D-2LS	LBCD 25 D-LS ^{s)}	0,106	2 600	3 800	1 430	2 320
LBCD 30 D	LBCD 30 D-2LS	LBCD 30 D-LS ^{s)}	0,166	3 800	5 600	2 320	3 750
LBCD 40 D	LBCD 40 D-2LS	LBCD 40 D-LS ^{s)}	0,316	6 550	9 650	3 350	5 700
LBCD 50 A	LBCD 50 A-2LS	LBCD 50 A-LS ^{s)}	0,44	8 000	11 200	4 150	6 950

LBCD in stainless steel

Designations			Mass	Basic load ratings ¹⁾			
with shields	with 2 double lip seals	with 1 double lip seal		dynamic C min ²⁾	max	static C ₀ min ²⁾	max
–			kg	N			
LBCD 12 D/HV6 ⁿ⁾	LBCD 12 D-2LS/HV6 ^{s)}	LBCD 12 D-LS/HV6 ⁿ⁾	0,02	800	1 220	570	930
LBCD 16 D/HV6 ⁿ⁾	LBCD 16 D-2LS/HV6 ^{s)}	LBCD 16 D-LS/HV6 ⁿ⁾	0,025	950	1 400	655	1 060
LBCD 20 D/HV6 ⁿ⁾	LBCD 20 D-2LS/HV6 ^{s)}	LBCD 20 D-LS/HV6 ⁿ⁾	0,055	1 730	2 550	1 120	1 800
LBCD 25 D/HV6 ⁿ⁾	LBCD 25 D-2LS/HV6 ^{s)}	LBCD 25 D-LS/HV6 ⁿ⁾	0,106	2 600	3 800	1 430	2 320
LBCD 30 D/HV6 ⁿ⁾	LBCD 30 D-2LS/HV6 ^{s)}	LBCD 30 D-LS/HV6 ⁿ⁾	0,166	3 800	5 600	2 320	3 750
LBCD 40 D/HV6 ⁿ⁾	LBCD 40 D-2LS/HV6 ^{s)}	LBCD 40 D-LS/HV6 ⁿ⁾	0,316	6 550	9 650	3 350	5 700
LBCD 50 A/HV6 ⁿ⁾	LBCD 50 A-2LS/HV6 ^{s)}	LBCD 50 A-LS/HV6 ⁿ⁾	0,44	8 000	11 200	4 150	6 950

Items without letter footnote are usually available from stock.

ⁿ⁾ Delivery time on request

^{s)} Delivery time usually 10 days for max. quantity of 4; larger quantities on request

¹⁾ Basic load ratings are valid for bearing steel and stainless steel variants. They must be reduced with stainless steel shafts only

²⁾ To be used if mounted randomly and the direction of max. load rating and the main load are not aligned

3.3.2 Standard linear ball bearings - LBCT

- Open design

- Sizes from 12 mm to 80 mm
- Open design for long strokes together with supported shafts
- Straight raceway design to support high loads
- Available in variants of 2 seals, 2 shields or seal and shield
- Available as bearing steel (standard) or stainless steel variant
- Factory pre-lubricated with SKF LGEP 2 grease, ready for use
- Clearance or preload determined by shaft and housing bore tolerance, adjustable in Ewellix units
- Suitable grease fittings for axial fixation are in **chapter 3.3.7**

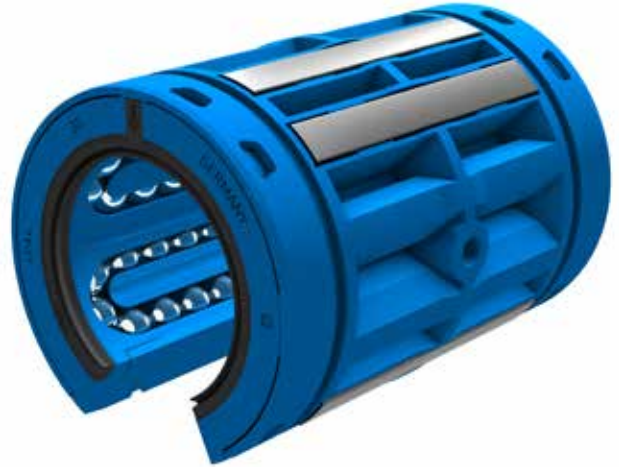

Pictured is LBCT 30 D-2LS ²⁾

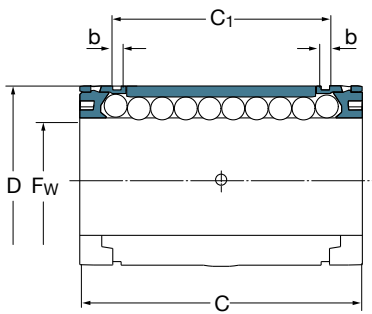

Picture shows LBCT D with shields ²⁾

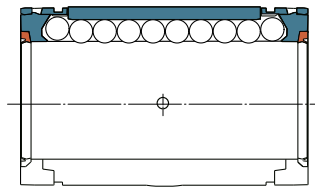

Picture shows LBCT D with 2 double lip seals ²⁾

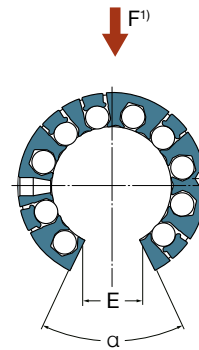

Dimensions							No. of ball rows
F_w mm	D	C	C_1	b	$E^{3)}$	α Deg.	-
12	22	32	22,6	1,3	8	78	4
16	26	36	24,6	1,3	10	78	4
20	32	45	31,2	1,6	11	60	5
25	40	58	43,7	1,85	13	60	5
30	47	68	51,7	1,85	14	50	5
40	62	80	60,3	2,15	19	50	5
50	75	100	77,3	2,65	23,6	50	6
60	90	125	101,3	3,15	29,6	54	6
80	120	165	133,3	4,15	38,4	54	6

¹⁾ Direction for max. load ratings

²⁾ Picture of non D-series bearing differs

³⁾ Minimum sector width at diameter F_w

LBCT

Designations			Mass	Basic load ratings ¹⁾			
with shields	with 2 double lip seals	with 1 double lip seal		dynamic C	max	static C ₀	max
–			kg	min ²⁾		min ²⁾	
LBCT 12 D	LBCT 12 D-2LS	LBCT 12 D-LS ^{s)}	0,016	695	1 220	510	1 020
LBCT 16 D	LBCT 16 D-2LS	LBCT 16 D-LS ^{s)}	0,020	765	1 500	585	1 370
LBCT 20 D	LBCT 20 D-2LS	LBCT 20 D-LS ^{s)}	0,046	1 860	3 200	1 340	2 700
LBCT 25 D ^{u)}	LBCT 25 D-2LS ^{u)}	LBCT 25 D-LS ^{u)}	0,090	2 700	4 650	2 000	4 000
LBCT 30 D	LBCT 30 D-2LS	LBCT 30 D-LS ^{s)}	0,142	4 150	7 200	3 000	6 000
LBCT 40 D ^{u)}	LBCT 40 D-2LS ^{u)}	LBCT 40 D-LS ^{u)}	0,272	6 400	11 000	4 250	8 500
LBCT 50 A	LBCT 50 A-2LS	LBCT 50 A-LS ^{s)}	0,39	5 850	13 400	5 300	12 200
LBCT 60 A	LBCT 60 A-2LS	LBCT 60 A-LS ^{s)}	0,72	8 650	20 400	8 000	18 000
LBCT 80 A	LBCT 80 A-2LS	LBCT 80 A-LS ^{s)}	1,67	16 000	37 500	14 000	32 000

LBCT in stainless steel

Designations			Mass	Basic load ratings ¹⁾			
with shields	with 2 double lip seals	with 1 double lip seal		dynamic C	max	static C ₀	max
–			kg	min ²⁾		min ²⁾	
LBCT 12 D/HV6 ⁿ⁾	LBCT 12 D-2LS/HV6 ^{s)}	LBCT 12 D-LS/HV6 ⁿ⁾	0,016	695	1 220	510	1 020
LBCT 16 D/HV6 ⁿ⁾	LBCT 16 D-2LS/HV6 ^{s)}	LBCT 16 D-LS/HV6 ⁿ⁾	0,020	765	1 500	585	1 370
LBCT 20 D/HV6 ⁿ⁾	LBCT 20 D-2LS/HV6 ^{s)}	LBCT 20 D-LS/HV6 ⁿ⁾	0,046	1 860	3 200	1 340	2 700
LBCT 25 D/HV6 ^{u)}	LBCT 25 D-2LS/HV6 ^{u)}	LBCT 25 D-LS/HV6 ^{u)}	0,090	2 700	4 650	2 000	4 000
LBCT 30 D/HV6 ⁿ⁾	LBCT 30 D-2LS/HV6 ^{s)}	LBCT 30 D-LS/HV6 ⁿ⁾	0,142	4 150	7 200	3 000	6 000
LBCT 40 D/HV6 ^{u)}	LBCT 40 D-2LS/HV6 ^{u)}	LBCT 40 D-LS/HV6 ^{u)}	0,272	6 400	11 000	4 250	8 500
LBCT 50 A/HV6 ⁿ⁾	LBCT 50 A-2LS/HV6 ^{s)}	LBCT 50 A-LS/HV6 ⁿ⁾	0,39	5 850	13 400	5 300	12 200
LBCT 60 A/HV6 ⁿ⁾	LBCT 60 A-2LS/HV6 ^{s)}	LBCT 60 A-LS/HV6 ⁿ⁾	0,72	8 650	20 400	8 000	18 000
LBCT 80 A/HV6 ⁿ⁾	LBCT 80 A-2LS/HV6 ^{s)}	LBCT 80 A-LS/HV6 ⁿ⁾	1,67	16 000	37 500	14 000	32 000

Items without letter footnote are usually available from stock.

ⁿ⁾ Delivery time on request

^{s)} Delivery time usually 10 days for max. quantity of 4; larger quantities on request

^{u)} Under development, A-series linear ball bearings of that size are available

¹⁾ Basic load ratings are valid for bearing steel and stainless steel variants. They must be reduced with stainless steel shafts only

²⁾ To be used if the direction of max. load rating and the main load are not aligned

3.3.3 Standard linear ball bearings - LBCF

- Open design, self-aligning

- Sizes from 12 mm to 50 mm
- Open design for long strokes together with supported shafts
- Possible tilting angle of ± 30 minutes of arc (self-aligning)
- Available in variants of 2 seals, 2 shields or seal and shield
- Available as bearing steel (standard) or stainless steel variant
- Factory pre-lubricated with SKF LGEP 2 grease, ready for use
- Clearance or preload determined by shaft and housing bore tolerance, adjustable in Ewellix units
- Suitable grease fittings for axial fixation are in **chapter 3.3.7**



Pictured is LBCF 30 D-2LS ²⁾

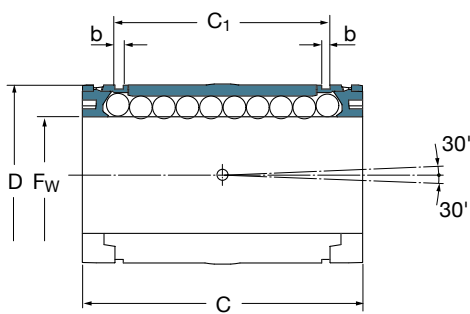

Picture shows LBCF D with shields ²⁾

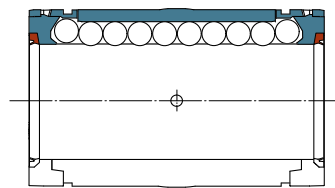

Picture shows LBCF D with 2 double lip seals ²⁾

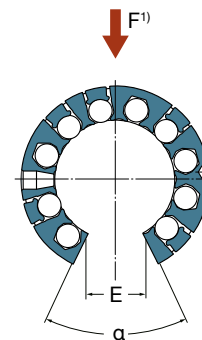

Dimensions							No. of ball rows
F _w mm	D	C	C ₁	b	E ³⁾	α Deg.	-
12	22	32	22,6	1,3	8	78	4
16	26	36	24,6	1,3	10	78	4
20	32	45	31,2	1,6	11	60	5
25	40	58	43,7	1,85	13	60	5
30	47	68	51,7	1,85	14	50	5
40	62	80	60,3	2,15	19	50	5
50	75	100	77,3	2,65	23,6	50	6

¹⁾ Direction for max. load ratings
²⁾ Picture of non D-series bearing differs
³⁾ Minimum sector width at diameter F_w

LBCF

Designations			Mass	Basic load ratings ¹⁾			
with shields	with 2 double lip seals	with 1 double lip seal		dynamic C	max	static C ₀	max
–			kg	min ²⁾		min ²⁾	
LBCF 12 D	LBCF 12 D-2LS	LBCF 12 D-LS ⁿ⁾	0,016	600	1 080	415	850
LBCF 16 D	LBCF 16 D-2LS	LBCF 16 D-LS ⁿ⁾	0,020	670	1 320	480	1 120
LBCF 20 D	LBCF 20 D-2LS	LBCF 20 D-LS ⁿ⁾	0,045	1 460	2 500	915	1 830
LBCF 25 D ^{u)}	LBCF 25 D-2LS ^{u)}	LBCF 25 D-LS ^{u)}	0,088	2 280	3 900	1 220	2 450
LBCF 30 D	LBCF 30 D-2LS	LBCF 30 D-LS ⁿ⁾	0,140	3 250	5 700	1 960	3 900
LBCF 40 D ^{u)}	LBCF 40 D-2LS ^{u)}	LBCF 40 D-LS ^{u)}	0,268	5 500	9 500	3 000	5 850
LBCF 50 A	LBCF 50 A-2LS	LBCF 50 A-LS ⁿ⁾	0,37	4 900	11 200	3 000	6 950

LBCF in stainless steel

Designations			Mass	Basic load ratings ¹⁾			
with shields	with 2 double lip seals	with 1 double lip seal		dynamic C	max	static C ₀	max
–			kg	min ²⁾		min ²⁾	
LBCF 12 D/HV6 ⁿ⁾	LBCF 12 D-2LS/HV6 ⁿ⁾	LBCF 12 D-LS/HV6 ^{s)}	0,016	600	1080	415	850
LBCF 16 D/HV6 ⁿ⁾	LBCF 16 D-2LS/HV6 ⁿ⁾	LBCF 16 D-LS/HV6 ^{s)}	0,020	670	1 320	480	1 120
LBCF 20 D/HV6 ⁿ⁾	LBCF 20 D-2LS/HV6 ⁿ⁾	LBCF 20 D-LS/HV6 ^{s)}	0,045	1 460	2 500	915	1 830
LBCF 25 D/HV6 ^{u)}	LBCF 25 D-2LS/HV6 ^{u)}	LBCF 25 D-LS/HV6 ^{u)}	0,088	2 280	3 900	1 220	2 450
LBCF 30 D/HV6 ⁿ⁾	LBCF 30 D-2LS/HV6 ⁿ⁾	LBCF 30 D-LS/HV6 ^{s)}	0,140	3 250	5 700	1 960	3 900
LBCF 40 D/HV6 ^{u)}	LBCF 40 D-2LS/HV6 ^{u)}	LBCF 40 D-LS/HV6 ^{u)}	0,268	5 500	9 500	3 000	5 850
LBCF 50 A/HV6 ⁿ⁾	LBCF 50 A-2LS/HV6 ⁿ⁾	LBCF 50 A-LS/HV6 ^{s)}	0,37	4 900	11 200	3 000	6 950

Items without letter footnote are usually available from stock.

ⁿ⁾ Delivery time on request

^{s)} Delivery time usually 10 days for max. quantity of 4; larger quantities on request

^{u)} Under development, A-series linear ball bearings of that size are available

¹⁾ Basic load ratings are valid for bearing steel and stainless steel variants. They must be reduced with stainless steel shafts only.

²⁾ To be used if the direction of max. load rating and the main load are not aligned

3.3.4 Standard linear ball bearings - LBHT

- Open design, heavy duty type

- Sizes from 20 mm to 50 mm
- Heavy duty type for maximum load ratings
- Open design for long strokes together with supported shafts
- Straight raceway design to support the high loads
- Available in variants of 2 seals, 2 shields or seal and shield
- Available as bearing steel (standard) or stainless-steel variant
- Factory pre-lubricated with SKF LGEP 2 grease, ready for use
- Clearance or preload determined by shaft and housing bore tolerance, adjustable in Ewellix units



Pictured is LBHT 30 A-2LS

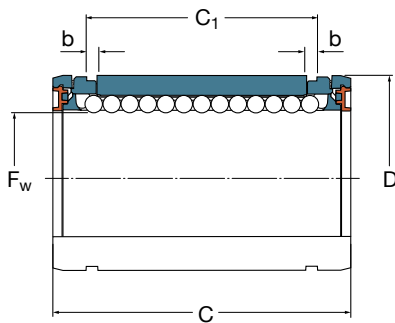

Picture shows LBHT with shields

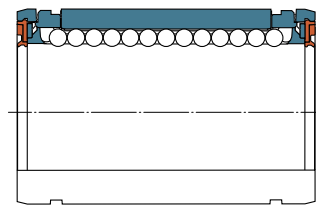

Picture shows LBHT with 2 double lip seals

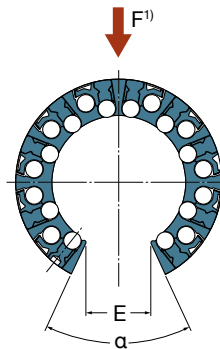

Dimensions							No. of ball rows
F_w mm	D	C	C_1	b	$E^{2)}$	α Deg.	-
20	32	45	31,2	1,6	10,8	60	8
25	40	58	43,7	1,85	13,2	60	9
30	47	68	51,7	1,85	14,2	50	10
40	62	80	60,3	2,15	18,7	50	10
50	75	100	77,3	2,65	23,6	50	10

¹⁾ Direction for max. load ratings

²⁾ Minimum sector width at diameter F_w

LBHT

Designations			Mass	Basic load ratings ¹⁾			
with shields	with 2 double lip seals	with 1 double lip seal		dynamic C	max	static C ₀	max
–			kg	min ²⁾	N	min ²⁾	
LBHT 20 A ^{s)}	LBHT 20 A-2LS	LBHT 20 A-LS ⁿ⁾	0,043	1 460	2 650	1 430	2 650
LBHT 25 A ^{s)}	LBHT 25 A-2LS	LBHT 25 A-LS ⁿ⁾	0,095	2 200	4 900	2 240	5 100
LBHT 30 A ^{s)}	LBHT 30 A-2LS	LBHT 30 A-LS ⁿ⁾	0,16	4 250	7 200	4 300	8 000
LBHT 40 A ^{s)}	LBHT 40 A-2LS	LBHT 40 A-LS ⁿ⁾	0,33	6 950	11 600	6 300	11 400
LBHT 50 A ^{s)}	LBHT 50 A-2LS	LBHT 50 A-LS ⁿ⁾	0,56	10 200	17 300	9 300	17 000

LBHT in stainless steel

Designations			Mass	Basic load ratings ¹⁾			
with shields	with 2 double lip seals	with 1 double lip seal		dynamic C	max	static C ₀	max
–			kg	min ²⁾	N	min ²⁾	
LBHT 20 A/HV6 ⁿ⁾	LBHT 20 A-2LS/HV6 ⁿ⁾	LBHT 20 A-LS/HV6 ⁿ⁾	0,043	1 460	2 650	1 430	2 650
LBHT 25 A/HV6 ⁿ⁾	LBHT 25 A-2LS/HV6 ⁿ⁾	LBHT 25 A-LS/HV6 ⁿ⁾	0,095	2 200	4 900	2 240	5 100
LBHT 30 A/HV6 ⁿ⁾	LBHT 30 A-2LS/HV6 ⁿ⁾	LBHT 30 A-LS/HV6 ⁿ⁾	0,16	4 250	7 200	4 300	8 000
LBHT 40 A/HV6 ⁿ⁾	LBHT 40 A-2LS/HV6 ⁿ⁾	LBHT 40 A-LS/HV6 ⁿ⁾	0,33	6 950	11 600	6 300	11 400
LBHT 50 A/HV6 ⁿ⁾	LBHT 50 A-2LS/HV6 ⁿ⁾	LBHT 50 A-LS/HV6 ⁿ⁾	0,56	10 200	17 300	9 300	17 000

Items without letter footnote are usually available from stock.

ⁿ⁾ Delivery time on request

^{s)} Delivery time usually 10 days for max. quantity of 4; larger quantities on request

¹⁾ Basic load ratings are valid for bearing steel and stainless steel variants. They must be reduced with stainless steel shafts only

²⁾ To be used if the direction of max. load rating and the main load are not aligned

3.3.5 Standard linear plain bearings - LPAR/LPAT

- Closed and open design

- Sizes from 5 mm to 80 mm in closed design and from 12 mm to 80 mm in open design
- Dimensional interchangeable with LBC linear bearings
- Self-lubricating material
- Equipped with lubrication hole
- Suitable grease fittings for axial fixation are in **chapter 3.3.7**

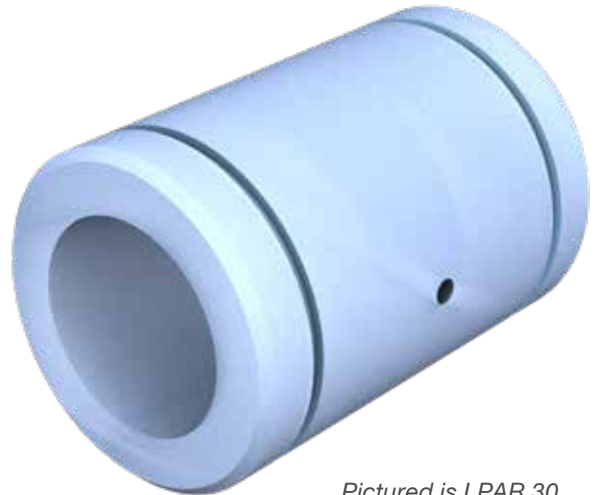

Pictured is LPAR 30

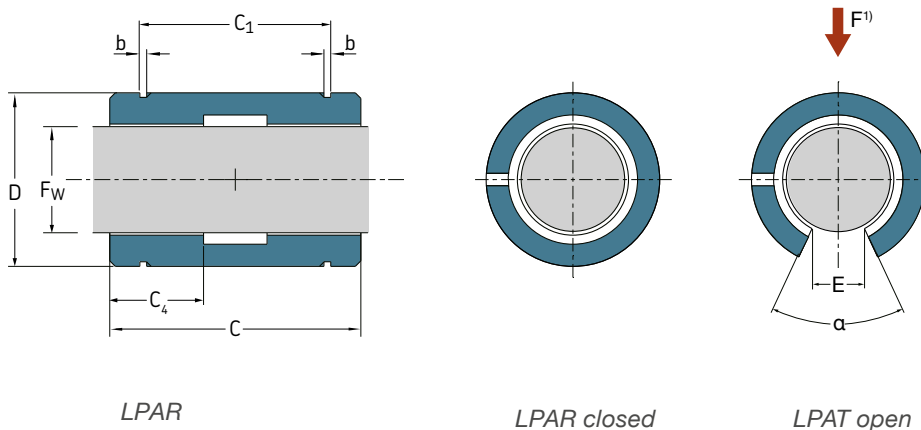

Dimensions							
F_w	D	C	C_1	b	C_4	$E^{2)}$	α
mm	-0,1						Deg.
5	12	22	14,2	1,1	8	-	-
8	16	25	16,2	1,1	9	-	-
12	22	32	22,6	1,3	11	7,6	78
16	26	36	24,6	1,3	13	10,4	78
20	32	45	31,2	1,6	17	10,8	60
25	40	58	43,7	1,85	22	13,2	60
30	47	68	51,7	1,85	25	14,2	50
40	62	80	60,3	2,15	27	18,7	50
50	75	100	77,3	2,65	32	23,6	50
60	90	125	101,3	3,15	40	29,6	54
80	120	165	133,3	4,15	52	38,4	54

¹⁾ Direction for max. load ratings

²⁾ Minimum sector width at diameter F_w

LPAR LPAT

Designations		Mass		Basic load ratings		
closed	open	closed	open	dynamic C at 0,1 m/s N	at 4 m/s	static C ₀
-		kg				
LPAR 5 ^{s) 1)}	-	0,003	-	320	8	1 120
LPAR 8 ^{s) 1)}	-	0,005	-	570	14	2 000
LPAR 12 ^{s)}	LPAT 12 ^{s)}	0,01	0,008	1 060	26	3 650
LPAR 16 ^{s)}	LPAT 16 ^{s)}	0,015	0,012	1 680	43	5 850
LPAR 20 ^{s)}	LPAT 20 ^{s)}	0,028	0,023	2 700	68	9 500
LPAR 25 ^{s)}	LPAT 25 ^{s)}	0,055	0,046	4 400	110	15 300
LPAR 30 ^{s)}	LPAT 30 ^{s)}	0,086	0,074	6 000	150	20 800
LPAR 40 ^{s)}	LPAT 40 ^{s)}	0,18	0,155	8 650	216	30 000
LPAR 50 ^{s)}	LPAT 50 ^{s)}	0,31	0,27	12 700	320	45 000
LPAR 60 ^{s)}	LPAT 60 ^{s)}	0,56	0,48	19 300	480	67 000
LPAR 80 ^{s)}	LPAT 80 ^{s)}	1,32	1,12	33 500	830	116 000

^{s)} Delivery time on request

^{s)} Delivery time usually 10 days for max. quantity of 4; larger quantities on request

¹⁾ Linear plain bearings LPAR 5 and LPAR 8 are without lubrication hole

3.3.6 Grease fittings - VN-LHC

- For axial and radial fixation of LBC and LPA linear bearings inside units
- For easy and suitable bearing regreasing
- Funnel lubrication fitting according to DIN 3405
- For grease guns with pointed or pin-pointed nozzles

Please find table appropriate grease fittings per bearing size in table below. For more details about axial and rotational fixation, please see **chapter 4.1.4**.

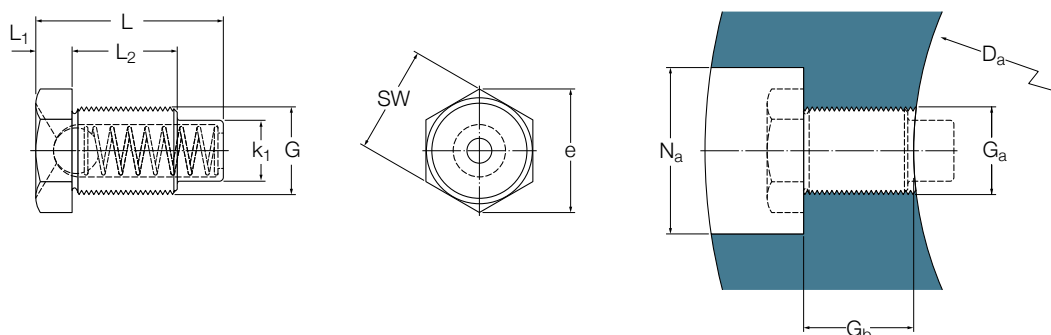

Dimensions								Designations Grease fitting	Recommended attachment dimensions				
Bearing F_w	Grease fitting G	L	L_1	L_2	k_1	e	SW		Housings				Recommended tightening torque Nm
mm	-	mm						D_a	G_a	$G_b \pm 0,2$	N_a ¹⁾		
12	M4	7,7	1,5	3,5	3	5,5	5	VN-LHC 20	22	M4	3,8	13	1,0
16	M4	7,7	1,5	3,5	3	5,5	5	VN-LHC 20	26	M4	3,8	13	1,0
20	M4	7,7	1,5	3,5	3	5,5	5	VN-LHC 20	32	M4	3,8	13	1,0
25	M5	11,1	2	5	3,5	6,6	6	VN-LHC 40	40	M5	5,2	15	2,2
30	M5	11,1	2	5	3,5	6,6	6	VN-LHC 40	47	M5	5,2	15	2,2
40	M5	11,1	2	5	3,5	6,6	6	VN-LHC 40	62	M5	5,2	15	2,2
50	M6	14,8	2,5	7	4,5	7,8	7	VN-LHC 50	75	M6	7,2	15	3,7
60	M8	20,5	3,5	10,5	6	11,1	10	VN-LHC 80	90	M8	11,2	18	9,3
80	M8	20,5	3,5	10,5	6	11,1	10	VN-LHC 80	120	M8	5,2	18	9,3

Items are usually available from stock.

¹⁾The bore diameter N_a of LUC and LUN housings in size 12,16 and 20 differs

3.4 Standard linear units

For flexible slide design, a comprehensive range of single linear bearing units is available. If flexible shaft width and slide length is required, they are the best choice for the application. An easier slide setup can be reached with tandem units with two bearings and quadro units with four bearings. To support different mounting possibilities, a flanged unit is available as well. All units are factory pre-greased and ready for immediate use. Ewellix offers units made by die-cast housings LUC and housings LUN. All open and closed units except the flanged ones are made from aluminium. The high precision unit design is optimized to provide high strength and rigidity. The Ewellix LUC unit type is extremely lightweight and keeps acceleration and inertia forces at a minimum. For applications that require preload, slotted units are offered. Open type single bearing units do have adjustable preload functionality.

Depending on the diameter units in closed and open design are equipped with linear bearings from A- or D-design. The housing design of open single units differs from A- to D-design. If the adjustable preload function of an open unit is used, an A-design bearing cannot be replaced by a D-design bearing.

For the utmost flexibility in design, the following variants can be chosen with all units: sealed or shielded, standard steel or stainless linear ball bearing or plain bearing. Each linear bearing unit is explained on the next pages with details about product data and designations. For more information on shaft blocks or shaft supports, please see **chapter 3.6**.



LUCR/LUCD



Standard LUCR/LUCD linear units offer flexible design to create economical linear slide systems. They are extremely lightweight and a perfect fit for low inertia and high acceleration. LUCR units from size 8 mm to 80 mm are equipped with rigid LBCR linear ball bearings or plain bearings, while LUCD units from size 12 mm to 50 mm are supplied with self-aligning LBCD linear ball bearings. All units are factory pre-greased and can be relubricated if necessary via the grease fitting. The grease fitting is also used for the fixation of the bearing in the housing. Exception is the size 8 mm unit, as it has bearings axially fixed with retaining rings.

LUCS/LUCE



Standard LUCS/LUCE linear units do have a similar design as LUCR/LUCD units. They are offering adjustable clearance or preload of the units via the slotted housing functionality. Please use the clearance adjustment carefully as it has an impact on service life. LUCS units from size 8 mm to 80 mm are equipped with rigid LBCR linear ball bearings or plain bearings, while LUCE units from size 12 mm to 50 mm are supplied with self-aligning LBCD linear ball bearings. All units are factory pre-greased and can be relubricated if necessary via the grease fitting. The grease fitting is also used for the fixation of the bearing in the housing. Exception is size 8 mm unit as it has bearings axially fixed with retaining rings.

LUCT/LUCF



Standard LUCT/LUCF linear units have an open design and are made for applications with heavy loads with long travel distances. LUCT units from size 12 mm to 80 mm are equipped with rigid LBCT linear ball bearings or plain bearings, while LUCF units from size 12 mm to 50 mm are supplied with self-aligning LBCF linear ball bearings. All units are factory pre-greased and can be relubricated if necessary via the grease fitting. The grease fitting is also used for the fixation of the bearing in the housing. In addition, the bearing clearance can be adjusted via the internal hexagon screw close to the opening of the housing.

LUCT BH



For maximum load rating, the open LUCT BH unit is equipped with the heavy duty type LBHT bearing. The LBHT bearing is equipped with the maximum number of raceways to reach the highest load ratings per size. These units from size 20 to 50 mm are factory pre-greased and can be relubricated if necessary using the grease fitting. The fixation of the bearing inside the housing is done by an internal hexagon screw.

LUN

Standard units in LUN design are different than the die-cast LUC linear bearing units which are made out of aluminium. The units can be bolted from both sides with appropriate screws. LUN units cover the linear bearing for its entire length by the housing. The LUN types are available in closed, slotted and open design. LUN units from 12 mm to 50 mm are equipped either with rigid linear ball bearings LBCR/LBCT, self-aligning bearings LBCD/LBCF or with plain bearings. They are factory pre-greased and can be relubricated if necessary via the grease fitting, which also keeps the bearing in axial and radial position. The slotted design offers adjustable clearance or preload of the units.

LVCR/LVCD

For flexible mounting purposes, the flanged linear bearing units are part of our range. The closed flange housing is made from cast iron. LVCR flanged units from size 12 mm to 80 mm are fitted with a rigid LBCR linear bearing or plain bearings, while LVCD flanged units from size 12 mm to 50 mm are equipped with self-aligning LBCD linear ball bearings. The bearings are axially located by a dowel pin. The flange is machined on both faces to enable mounting on the front or rear side in either direction. Flanged linear bearing units are factory pre-lubricated and are not made for relubrication.

LTC

Tandem linear units LTC consist of a solid aluminium housing with two linear ball bearings mounted one behind the other. Tandem linear units are a perfect fit for linear guiding systems of any required width. The units can be attached to a supporting surface from both sides using the appropriate screws and are available in closed and open design. The LTC units from size 12 mm to 50 mm are equipped either with rigid linear ball bearings LBCR/LBCT, self-aligning bearings LBCD/LBCF or with plain bearings. Tandems are factory pre-greased and can be relubricated if necessary via the grease fitting, which also keeps the bearing in axial and radial position.

LQC

Quadro linear units LQC are linear slides ready to use with Ewellix shafts and shaft blocks. They consist of a one-piece aluminium housing with two parallel rows of two linear ball bearings. Quadro units can be attached to a supporting surface from both sides using the appropriate screws and are available in open and closed design. The LQC units from size 12 mm to 50 mm are equipped either with rigid linear ball bearings LBCR/LBCT, self-aligning bearings LBCD/LBCF or with plain bearings. Quadro units are factory pre-greased and can be relubricated if necessary via the grease fitting, which also keeps the bearing in axial and radial position. LQC in size 8 mm cannot be relubricated and can only be equipped with LBCR linear bearings and plain bearings.

3.4.1 Standard linear units - LUCR/LUCD

- LUCR with rigid LBCR bearing
 - LUCD with self-aligning LBCD bearing
 - LUCR PA with LPAR linear plain bearing
- Closed design in sizes from 8 mm to 80 mm
 - Lightweight die-cast aluminium housing
 - Available in variants of 2 seals or 2 shields
 - Available as bearing steel (standard) or stainless steel variant
 - Factory pre-lubricated with SKF LGEP 2 grease, ready for use
 - Equipped with grease fitting
 - Able to bolt from top or bottom side

Please find suitable shaft blocks or shaft supports in **chapter 3.6** and shafts in **chapter 3.7**



Pictured is LUCD 30 D-2LS ²⁾

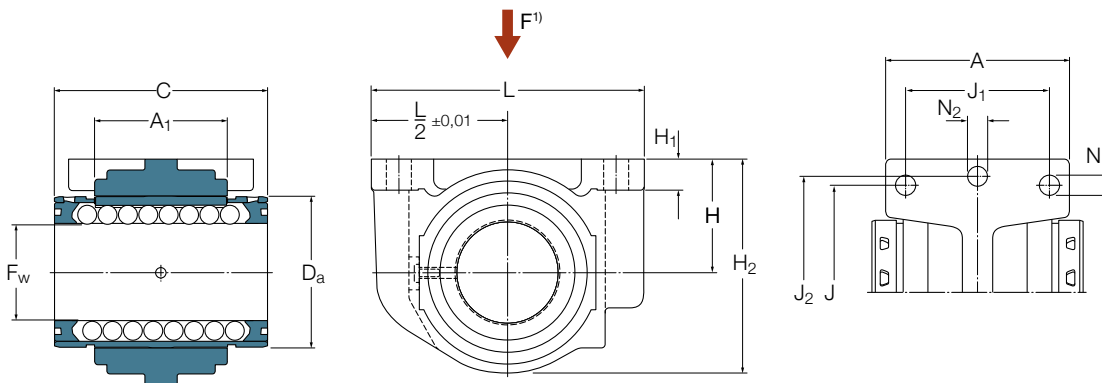

Picture shows LUCD D with shields ²⁾

Dimensions													
F_w	A	A_1	C	D_a	$H_{\pm 0,01}$	H_1	H_2	J	J_1	J_2	$L^{3)}$	$N^{4)}$	$N_2^{4)}$
mm													
8	27	14	25	16	15	5,5	28	25	20	35	45	3,2	5,3
12	31	20	32	22	18	6	34,5	32	23	42	52	4,3	5,3
16	35	22	36	26	22	7	40,5	40	26	46	56	4,3	5,3
20	41	28	45	32	25	8	48	45	32	58	70	4,3	6,4
25	52	40	58	40	30	10	58	60	40	68	80	5,3	6,4
30	59	48	68	47	35	10	67	68	45	76	88	6,4	6,4
40	74	56	80	62	45	12	85	86	58	94	108	8,4	8,4
50	66	72	100	75	50	14	99	108	50	116	135	8,4	10,5
60	84	95	125	90	60	18	118	132	65	138	160	10,5	13
80	113	125	165	120	80	22	158	170	90	180	205	13	13

¹⁾ Direction for max. load ratings
²⁾ Picture with non D-series bearing or plain bearing differs
³⁾ For units from size 50 to 80: Tolerance $L/2 \pm 0,02$
⁴⁾ For cylinder head screws with internal hexagon according to ISO 4762

LUCR

Designations				Mass	Basic load ratings ¹⁾			
LBCR bearing inside with shields		Stainless steel variant of LBCR bearing inside with 2 double lip seals			dynamic C		static C ₀	
–	–	–	–	kg	min	max	min	max
LUCR 8 ^{2) s)}	LUCR 8-2LS ^{2) s)}	LUCR 8/HV6 ^{2) n)}	LUCR 8 -2LS/HV6 ^{n) 2)}	0,027	490	570	355	355
LUCR 12 D ^{s)}	LUCR 12 D-2LS	LUCR 12 D/HV6 ⁿ⁾	LUCR 12 D-2LS/HV6 ⁿ⁾	0,058	930	1 370	695	1 120
LUCR 16 D ^{s)}	LUCR 16 D-2LS	LUCR 16 D/HV6 ⁿ⁾	LUCR 16 D-2LS/HV6 ⁿ⁾	0,076	1 080	1 600	800	1 290
LUCR 20 D ^{s)}	LUCR 20 D-2LS	LUCR 20 D/HV6 ⁿ⁾	LUCR 20 D-2LS/HV6 ⁿ⁾	0,157	2 200	3 250	1 630	2 650
LUCR 25 D ^{s)}	LUCR 25 D-2LS	LUCR 25 D/HV6 ⁿ⁾	LUCR 25 D-2LS/HV6 ⁿ⁾	0,308	3 100	4 550	2 360	3 800
LUCR 30 D ^{s)}	LUCR 30 D-2LS	LUCR 30 D/HV6 ⁿ⁾	LUCR 30 D-2LS/HV6 ⁿ⁾	0,450	4 800	7 100	3 550	5 700
LUCR 40 D ^{s)}	LUCR 40 D-2LS	LUCR 40 D/HV6 ⁿ⁾	LUCR 40 D-2LS/HV6 ⁿ⁾	0,799	7 650	11 200	5 100	8 300
LUCR 50 ^{s)}	LUCR 50-2LS	LUCR 50/HV6 ⁿ⁾	LUCR 50-2LS/HV6 ⁿ⁾	1,215	9 650	13 400	7 200	12 200
LUCR 60 ^{s)}	LUCR 60-2LS ^{s)}	LUCR 60/HV6 ⁿ⁾	LUCR 60-2LS/HV6 ⁿ⁾	2,160	14 600	20 400	11 200	18 000
LUCR 80 ^{s)}	LUCR 80-2LS ^{s)}	LUCR 80/HV6 ⁿ⁾	LUCR 80-2LS/HV6 ⁿ⁾	5,155	26 500	37 500	19 600	32 000

LUCD

Designations				Mass	Basic load ratings ¹⁾			
Self-aligning LBCD bearing inside with shields		Stainless steel variant of self-aligning LBCD bearing inside with 2 double lip seals			dynamic C		static C ₀	
–	–	–	–	kg	min	max	min	max
LUCD 12 D ^{s)}	LUCD 12 D-2LS	LUCD 12 D/HV6 ⁿ⁾	LUCD 12 D-2LS/HV6 ⁿ⁾	0,058	800	1 220	570	930
LUCD 16 D ^{s)}	LUCD 16 D-2LS	LUCD 16 D/HV6 ⁿ⁾	LUCD 16 D-2LS/HV6 ⁿ⁾	0,075	950	1 400	655	1 060
LUCD 20 D ^{s)}	LUCD 20 D-2LS	LUCD 20 D/HV6 ⁿ⁾	LUCD 20 D-2LS/HV6 ⁿ⁾	0,156	1 730	2 550	1 120	1 800
LUCD 25 D ^{s)}	LUCD 25 D-2LS	LUCD 25 D/HV6 ⁿ⁾	LUCD 25 D-2LS/HV6 ⁿ⁾	0,306	2 600	3 800	1 430	2 320
LUCD 30 D ^{s)}	LUCD 30 D-2LS	LUCD 30 D/HV6 ⁿ⁾	LUCD 30 D-2LS/HV6 ⁿ⁾	0,448	3 800	5 600	2 320	3 750
LUCD 40 D ^{s)}	LUCD 40 D-2LS	LUCD 40 D/HV6 ⁿ⁾	LUCD 40 D-2LS/HV6 ⁿ⁾	0,792	6 550	9 650	3 350	5 700
LUCD 50 ^{s)}	LUCD 50-2LS	LUCD 50/HV6 ⁿ⁾	LUCD 50-2LS/HV6 ⁿ⁾	1,195	8 000	11 200	4 150	6 950

LUCR PA

Designations	Mass	Basic load ratings		static ³⁾ C ₀
		dynamic C	dynamic C	
LPAR linear plain bearing inside		at 0,1 m/s	at 4 m/s	
–	kg	N		
LUCR 8 PA ^{n) 2)}	0,023	570	14	2 000
LUCR 12 PA ⁿ⁾	0,048	1 060	26	3 650
LUCR 16 PA ⁿ⁾	0,065	1 680	43	5 850
LUCR 20 PA ⁿ⁾	0,129	2 700	68	9 500
LUCR 25 PA ⁿ⁾	0,255	4 400	110	15 300
LUCR 30 PA ⁿ⁾	0,368	6 000	150	20 800
LUCR 40 PA ⁿ⁾	0,656	8 650	216	30 000
LUCR 50 PA ⁿ⁾	1,065	12 700	320	45 000
LUCR 60 PA ⁿ⁾	1,900	19 300	480	67 000
LUCR 80 PA ⁿ⁾	4,575	33 500	830	116 000

Items without letter footnote are usually available from stock.

ⁿ⁾ Delivery time on request

^{s)} Delivery time usually 10 days for max. quantity of 4; larger quantities on request

¹⁾ Basic load ratings are valid for bearing steel and stainless steel variants. They must be reduced with stainless steel shafts only

²⁾ Linear bearings fitted to these units are secured with retaining rings according to DIN 471, cannot be relubricated and are not self-aligning

³⁾ Valid if the loads on the housing are exclusively in direction of red arrow. See dimensional drawing on left page

3.4.2 Standard linear units - LUCS/LUCE

- LUCS with rigid LBCR bearing
- LUCE with self-aligning LBCD bearing

- Slotted design for adjustable clearance in sizes from 8 mm to 80 mm
- Lightweight die-cast aluminium housing
- Available in variants of 2 seals or 2 shields
- Available as bearing steel (standard) or stainless steel variant
- Factory pre-lubricated with SKF LGEP 2 grease, ready for use
- Equipped with grease fitting
- Able to bolt from top or bottom side

Please find suitable shaft blocks or shaft supports in **chapter 3.6** and shafts in **chapter 3.7**



Pictured is LUCE 30 D-2LS 2)

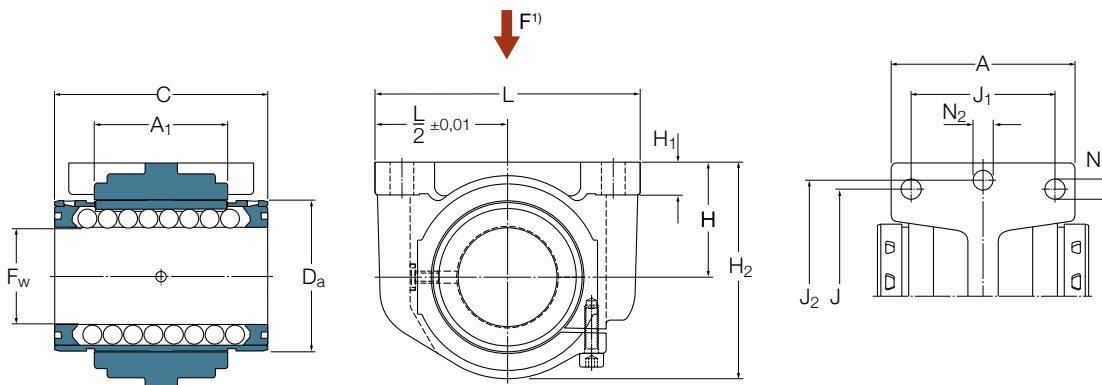

Picture shows LUCE D with shields 2)

Dimensions

F_w	A	A_1	C	D_a	$H_{\pm 0,01}$	H_1	H_2	J	J_1	J_2	$L^{3)}$	$N^{4)}$	$N_2^{4)}$
mm													
8	27	14	25	16	15	5,5	28	25	20	35	45	3,2	5,3
12	31	20	32	22	18	6	34,5	32	23	42	52	4,3	5,3
16	34,5	22	36	26	22	7	40,5	40	26	46	56	4,3	5,3
20	41	28	45	32	25	8	48	45	32	58	70	4,3	6,4
25	52	40	58	40	30	10	58	60	40	68	80	5,3	6,4
30	59	48	68	47	35	10	67	68	45	76	88	6,4	6,4
40	74	56	80	62	45	12	85	86	58	94	108	8,4	8,4
50	66	72	100	75	50	14	99	108	50	116	135	8,4	10,5
60	84	95	125	90	60	18	118	132	65	138	160	10,5	13
80	113	125	165	120	80	22	158	170	90	180	205	13	13

¹⁾ Direction for max. load ratings

²⁾ Picture with non D-series bearing or plain bearing differs

³⁾ For units from size 50 to 80: Tolerance $L/2 \pm 0,02$

⁴⁾ For cylinder head screws with internal hexagon according to ISO 4762

LUCS

Designations				Mass kg	Basic load ratings ¹⁾			
LBCR bearing inside with shields		Stainless steel variant of LBCR bearing inside with 2 double lip seals			dynamic C		static C ₀	
-		-		min		max		
LUCS 8 ^{2) s)}	LUCS 8-2LS ^{2) s)}	LUCS 8/HV6 ^{2) n)}	LUCS 8-2LS/HV6 ^{2) n)}	0,028	490	570	355	500
LUCS 12 D ^{s)}	LUCS 12 D-2LS ^{s)}	LUCS 12 D/HV6 ⁿ⁾	LUCS 12 D-2LS/HV6 ⁿ⁾	0,058	930	1 370	695	1 120
LUCS 16 D ^{s)}	LUCS 16 D-2LS ^{s)}	LUCS 16 D/HV6 ⁿ⁾	LUCS 16 D-2LS/HV6 ⁿ⁾	0,077	1 080	1 600	800	1 290
LUCS 20 D ^{s)}	LUCS 20 D-2LS ^{s)}	LUCS 20 D/HV6 ⁿ⁾	LUCS 20 D-2LS/HV6 ⁿ⁾	0,160	2 200	3 250	1 630	2 650
LUCS 25 D ^{s)}	LUCS 25 D-2LS ^{s)}	LUCS 25 D/HV6 ⁿ⁾	LUCS 25 D-2LS/HV6 ⁿ⁾	0,310	3 100	4 550	2 360	3 800
LUCS 30 D ^{s)}	LUCS 30 D-2LS ^{s)}	LUCS 30 D/HV6 ⁿ⁾	LUCS 30 D-2LS/HV6 ⁿ⁾	0,452	4 800	7 100	3 550	5 700
LUCS 40 D ^{s)}	LUCS 40 D-2LS ^{s)}	LUCS 40 D/HV6 ⁿ⁾	LUCS 40 D-2LS/HV6 ⁿ⁾	0,795	7 650	11 200	5 100	8 300
LUCS 50 ^{s)}	LUCS 50-2LS ^{s)}	LUCS 50/HV6 ⁿ⁾	LUCS 50-2LS/HV6 ⁿ⁾	1,217	9 650	11 200	7 200	12 200
LUCS 60 ^{s)}	LUCS 60-2LS ^{s)}	LUCS 60/HV6 ⁿ⁾	LUCS 60-2LS/HV6 ⁿ⁾	2,191	14 600	20 400	11 200	18 000
LUCS 80 ^{s)}	LUCS 80-2LS ^{s)}	LUCS 80/HV6 ⁿ⁾	LUCS 80-2LS/HV6 ⁿ⁾	5,110	26 500	37 500	19 600	32 000

LUCE

Designations				Mass kg	Basic load ratings ¹⁾			
Self-aligning LBCD bearing inside with shields		Stainless steel variant of self-aligning LBCD bearing inside with 2 double lip seals			dynamic C		static C ₀	
-		-		min		max		
LUCE 12 D ^{s)}	LUCE 12 D-2LS ^{s)}	LUCE 12 D/HV6 ⁿ⁾	LUCE 12 D-2LS/HV6 ⁿ⁾	0,058	800	1 220	570	930
LUCE 16 D ^{s)}	LUCE 16 D-2LS ^{s)}	LUCE 16 D/HV6 ⁿ⁾	LUCE 16 D-2LS/HV6 ⁿ⁾	0,076	950	1 400	655	1 060
LUCE 20 D ^{s)}	LUCE 20 D-2LS ^{s)}	LUCE 20 D/HV6 ⁿ⁾	LUCE 20 D-2LS/HV6 ⁿ⁾	0,159	1 730	2 550	1 120	1 800
LUCE 25 D ^{s)}	LUCE 25 D-2LS ^{s)}	LUCE 25 D/HV6 ⁿ⁾	LUCE 25 D-2LS/HV6 ⁿ⁾	0,308	2 600	3 800	1 430	2 320
LUCE 30 D ^{s)}	LUCE 30 D-2LS ^{s)}	LUCE 30 D/HV6 ⁿ⁾	LUCE 30 D-2LS/HV6 ⁿ⁾	0,450	3 800	5 600	2 320	3 750
LUCE 40 D ^{s)}	LUCE 40 D-2LS ^{s)}	LUCE 40 D/HV6 ⁿ⁾	LUCE 40 D-2LS/HV6 ⁿ⁾	0,788	6 550	9 650	3 350	5 700
LUCE 50 ^{s)}	LUCE 50-2LS ^{s)}	LUCE 50/HV6 ⁿ⁾	LUCE 50-2LS/HV6 ⁿ⁾	1,197	8 000	11 200	4 150	6 950

²⁾ Delivery time on request³⁾ Delivery time usually 10 days for max. quantity of 4; larger quantities on request¹⁾ Basic load ratings are valid for bearing steel and stainless steel variants. They must be reduced with stainless steel shafts only²⁾ Linear ball bearings fitted to these units are secured with retaining rings according to DIN 471, cannot be relubricated and are not self-aligning

3.4.3 Standard linear units - LUCT/LUCF

- LUCT with rigid LBCT bearing
 - LUCF with self-aligning LBCF bearing
 - LUCT PA with LPAT linear plain bearing
- Open design in sizes from 12 mm to 80 mm with adjustable clearance
 - Lightweight die-cast aluminium housing
 - Available in variants of 2 seals or 2 shields
 - Available as bearing steel (standard) or stainless steel variant
 - Factory pre-lubricated with SKF LGEP 2 grease, ready for use
 - Equipped with grease fitting
 - Able to bolt from top or bottom side

Please find suitable shaft blocks or shaft supports in **chapter 3.6** and shafts in **chapter 3.7**



Pictured is LUCF 30 D-2LS ²⁾

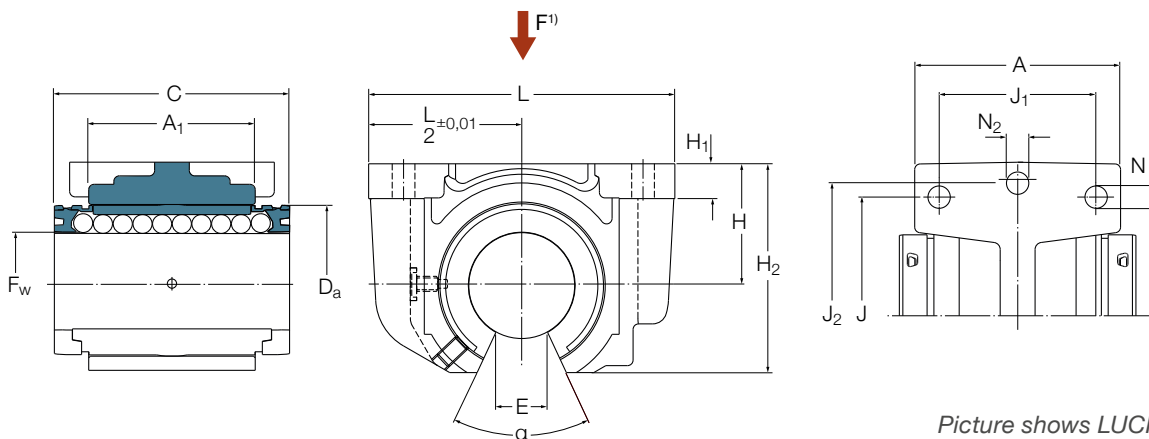

Picture shows LUCF D with shields ²⁾

Dimensions

F_w	A	A_1	C	D_a	$H_{\pm 0,01}$	H_1	H_2	J	J_1	J_2	$L^{3)}$	$N^{4)}$	$N_2^{4)}$	$E^{5)}$	α
mm															Deg.
12	31	20	32	22	18	6	28	32	23	42	52	4,3	5,3	7,6	78
16	34,5	22	36	26	22	7	35	40	26	46	56	4,3	5,3	10,4	78
20	41	28	45	32	25	8	42	45	32	58	70	4,3	6,4	10,8	60
25	52	40	58	40	30	10	51	60	40	68	80	5,3	6,4	13,2	60
30	59	48	68	47	35	10	60	68	45	76	88	6,4	6,4	14,2	50
40	74	56	80	62	45	12	77	86	58	94	108	8,4	8,4	18,7	50
50	66	72	100	75	50	14	88	108	50	116	135	8,4	10,5	23,6	50
60	84	95	125	90	60	18	105	132	65	138	160	10,5	13,0	29,6	54
80	113	125	165	120	80	22	140	170	90	180	205	13,0	13,0	38,4	54

¹⁾ Direction for max. load ratings

²⁾ Picture with non D-series bearing or plain bearing differs

³⁾ For units from size 50 to 80: Tolerance $L/2 \pm 0,02$

⁴⁾ For cylinder head screws with internal hexagon according to ISO 4762

⁵⁾ Minimum sector width at diameter F_w

LUCT

Designations				Mass	Basic load ratings ¹⁾			
LBCT bearing inside		Stainless steel variant of LBCT bearing inside			dynamic C	static C ₀		
with shields	with 2 double lip seals	with shields	with 2 double lip seals	kg	min	max	min	max
–	–	–	–		N	–	–	–
LUCT 12 D ^{s)}	LUCT 12 D-2LS	LUCT 12 D/HV6 ⁿ⁾	LUCT 12 D-2LS/HV6 ⁿ⁾	0,050	695	1 220	510	1 020
LUCT 16 D ^{s)}	LUCT 16 D-2LS	LUCT 16 D/HV6 ⁿ⁾	LUCT 16 D-2LS/HV6 ⁿ⁾	0,065	765	1 500	585	1 370
LUCT 20 D ^{s)}	LUCT 20 D-2LS	LUCT 20 D/HV6 ⁿ⁾	LUCT 20 D-2LS/HV6 ⁿ⁾	0,138	1 860	3 200	1 340	2 700
LUCT 25 D ^{u)}	LUCT 25 D-2LS ^{u)}	LUCT 25 D/HV6 ^{u)}	LUCT 25 D-2LS/HV6 ^{u)}	0,269	2 700	4 650	2 000	4 000
LUCT 30 D ^{s)}	LUCT 30 D-2LS	LUCT 30 D/HV6 ⁿ⁾	LUCT 30 D-2LS/HV6 ⁿ⁾	0,396	4 150	7 200	3 000	6 000
LUCT 40 D ^{u)}	LUCT 40 D-2LS ^{u)}	LUCT 40 D/HV6 ^{u)}	LUCT 40 D-2LS/HV6 ^{u)}	0,681	6 400	11000	4 250	8 500
LUCT 50 ^{s)}	LUCT 50-2LS	LUCT 50/HV6 ⁿ⁾	LUCT 50-2LS/HV6 ⁿ⁾	1,055	5 850	13 400	5 300	12 200
LUCT 60 ^{s)}	LUCT 60-2LS	LUCT 60/HV6 ⁿ⁾	LUCT 60-2LS/HV6 ⁿ⁾	1,903	8 650	20 400	8 000	18 000
LUCT 80 ^{s)}	LUCT 80-2LS	LUCT 80/HV6 ⁿ⁾	LUCT 80-2LS/HV6 ⁿ⁾	4,531	16 000	37 500	14 000	32 000

LUCF

Designations				Mass	Basic load ratings ¹⁾			
Self-aligning LBCF bearing inside		Stainless steel variant of self-aligning LBCF bearing inside			dynamic C	static C ₀		
with shields	with 2 double lip seals	with shields	with 2 double lip seals	kg	min	max	min	max
–	–	–	–		N	–	–	–
LUCF 12 D ^{s)}	LUCF 12 D-2LS	LUCF 12 D/HV6 ⁿ⁾	LUCF 12 D-2LS/HV6 ⁿ⁾	0,050	600	1 080	415	850
LUCF 16 D ^{s)}	LUCF 16 D-2LS	LUCF 16 D/HV6 ⁿ⁾	LUCF 16 D-2LS/HV6 ⁿ⁾	0,065	670	1 320	480	1 120
LUCF 20 D ^{s)}	LUCF 20 D-2LS	LUCF 20 D/HV6 ⁿ⁾	LUCF 20 D-2LS/HV6 ⁿ⁾	0,137	1 460	2 500	915	1 830
LUCF 25 D ^{u)}	LUCF 25 D-2LS ^{u)}	LUCF 25 D/HV6 ^{u)}	LUCF 25 D-2LS/HV6 ^{u)}	0,267	2 280	3 900	1 220	2 450
LUCF 30 D ^{s)}	LUCF 30 D-2LS	LUCF 30 D/HV6 ⁿ⁾	LUCF 30 D-2LS/HV6 ⁿ⁾	0,394	3 250	5 700	1 960	3 900
LUCF 40 D ^{u)}	LUCF 40 D-2LS ^{u)}	LUCF 40 D/HV6 ^{u)}	LUCF 40 D-2LS/HV6 ^{u)}	0,677	5 500	9 500	3 000	5 850
LUCF 50 ^{s)}	LUCF 50-2LS	LUCF 50/HV6 ⁿ⁾	LUCF 50-2LS/HV6 ⁿ⁾	1,035	4 900	11 200	3 000	6 950

LUCT PA

Designations	Mass	Basic load ratings		static ²⁾ C ₀
		dynamic C	dynamic C	
LPAT linear plain bearing inside		at 0,1 m/s	at 4 m/s	
–	kg	N	N	
LUCT 12 PA ⁿ⁾	0,042	1 060	26	3 650
LUCT 16 PA ⁿ⁾	0,057	1 680	43	5 850
LUCT 20 PA ⁿ⁾	0,115	2 700	68	9 500
LUCT 25 PA ⁿ⁾	0,225	4 400	110	15 300
LUCT 30 PA ⁿ⁾	0,328	6 000	150	20 800
LUCT 40 PA ⁿ⁾	0,564	8 650	216	30 000
LUCT 50 PA ⁿ⁾	0,935	12 700	320	45 000
LUCT 60 PA ⁿ⁾	1,663	19 300	480	67 000
LUCT 80 PA ⁿ⁾	3,981	33 500	830	116 000

Items without letter footnote are usually available from stock.

ⁿ⁾ Delivery time on request

^{s)} Delivery time usually 10 days for max. quantity of 4; larger quantities on request

^{u)} Under development, A-series linear ball bearings of that size are available

¹⁾ Basic load ratings are valid for bearing steel and stainless steel variants. They must be reduced with stainless steel shafts only

²⁾ Valid if the loads onto the housing are exclusively in direction of red arrow. See dimensional drawing on left page

3.4.4 Standard linear units - LUCT BH

- LUCT BH with rigid LBHT heavy duty bearing

- Open heavy duty design in sizes from 20 mm to 50 mm
- Lightweight die-cast aluminium housing
- Available in variants of 2 seals or 2 shields
- Available as bearing steel (standard) or stainless steel variant
- Factory pre-lubricated with SKF LGEP 2 grease, ready for use
- Equipped with grease fitting
- Able to bolt from top or bottom side

Please find suitable shaft blocks or shaft supports in **chapter 3.6** and shafts in **chapter 3.7**



Pictured is LUCT 30 BH-2LS ²⁾

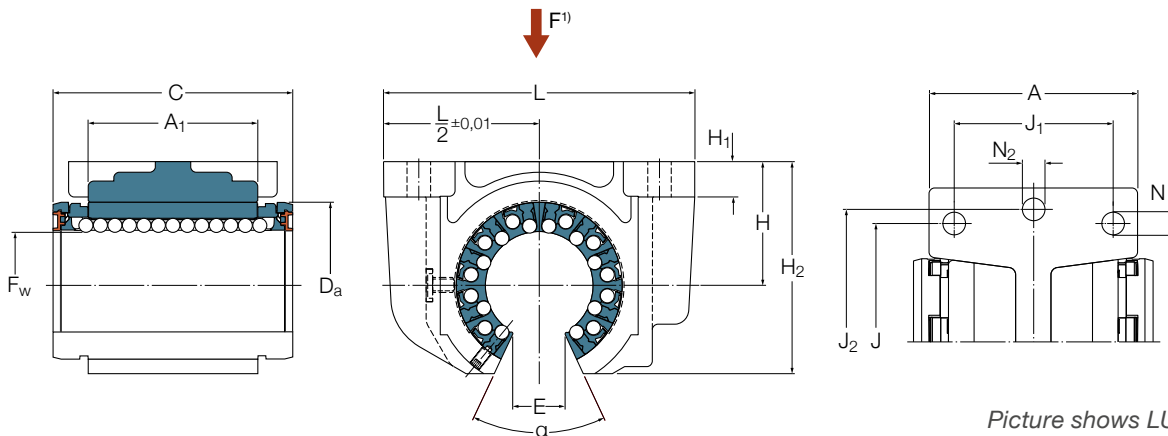

Picture shows LUCT BH with shields

Dimensions															
F_w	A	A_1	C	D_a	$H_{\pm 0,01}$	H_1	H_2	J	J_1	J_2	$L^{2)}$	$N^{3)}$	$N_2^{3)}$	$E^{4)}$	α
mm															Deg.
20	41	28	45	32	25	8	42	45	32	58	70	4,3	6,4	10,8	60,0
25	52	40	58	40	30	10	51	60	40	68	80	5,3	6,4	13,2	60,0
30	59	48	68	47	35	10	60	68	45	76	88	6,4	6,4	14,2	50,0
40	74	56	80	62	45	12	77	86	58	94	108	8,4	8,4	18,7	50,0
50	66	72	100	75	50	14	88	108	50	116	135	8,4	10,5	23,6	50,0

¹⁾ Direction for max. load ratings

²⁾ For units from size 50: Tolerance $L/2 \pm 0,02$

³⁾ For cylinder head screws with internal hexagon according to ISO 4762

⁴⁾ Minimum sector width at diameter F_w

LUCT BH

Designations				Mass	Basic load ratings ¹⁾			
LBHT bearing inside		Stainless steel variant of LBHT bearing inside			dynamic C	static C ₀		
with shields	with 2 double lip seals	with shields	with 2 double lip seals	kg	min	max	min	max
–					N			
LUCT 20 BH ⁿ⁾	LUCT 20 BH-2LS ^{s)}	LUCT 20 BH/HV6 ⁿ⁾	LUCT 20 BH-2LS/HV6 ⁿ⁾	0,14	1 460	2 650	1 430	2 650
LUCT 25 BH ⁿ⁾	LUCT 25 BH-2LS ^{s)}	LUCT 25 BH/HV6 ⁿ⁾	LUCT 25 BH-2LS/HV6 ⁿ⁾	0,275	2 200	4 900	2 240	5 100
LUCT 30 BH ⁿ⁾	LUCT 30 BH-2LS ^{s)}	LUCT 30 BH/HV6 ⁿ⁾	LUCT 30 BH-2LS/HV6 ⁿ⁾	0,48	4 250	7 200	4 300	8 000
LUCT 40 BH ⁿ⁾	LUCT 40 BH-2LS ^{s)}	LUCT 40 BH/HV6 ⁿ⁾	LUCT 40 BH-2LS/HV6 ⁿ⁾	0,86	6 950	11 600	6 300	11 400
LUCT 50 BH ⁿ⁾	LUCT 50 BH-2LS ^{s)}	LUCT 50 BH/HV6 ⁿ⁾	LUCT 50 BH-2LS/HV6 ⁿ⁾	1,44	10 200	17 300	9 300	17 000

Items without letter footnote are usually available from stock.

ⁿ⁾ Delivery time on request

^{s)} Delivery time usually 10 days for max. quantity of 4; larger quantities on request

¹⁾ Basic load ratings are valid for bearing steel and stainless steel variants. They must be reduced with stainless steel shafts only

3.4.5 Standard linear units - LUNR/LUND

- LUNR with rigid LBCR bearing
 - LUND with self-aligning LBCD bearing
 - LUNR PA with LPAR linear plain bearing
- Closed design in sizes from 12 mm to 50 mm
 - Aluminium housing covers the entire bearing length
 - Available in variants of 2 seals or 2 shields
 - Available as bearing steel (standard) or stainless steel variant
 - Factory pre-lubricated with SKF LGEP 2 grease, ready for use
 - Equipped with grease fitting
 - Able to bolt from top or bottom side

Please find suitable shaft blocks or shaft supports in **chapter 3.6** and shafts in **chapter 3.7**

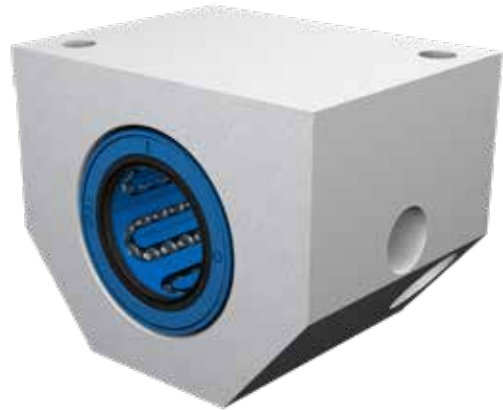

Pictured is LUND 30 D-2LS ²⁾

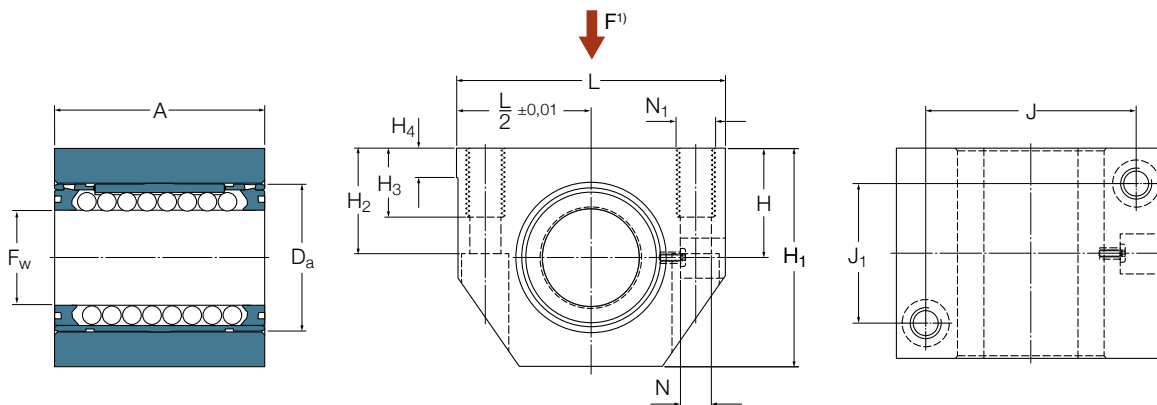

Picture shows LUND D with shields ²⁾

Dimensions												
F _w	A	D _a	H ±0,01	H ₁	H ₂	H ₃	H ₄	J	J ₁	L	N ³⁾	N ₁
mm												-
12	32	22	18	35	16,5	11	6	32	23	43	4,3	M5
16	37	26	22	42	21	13	7	40	26	53	5,3	M6
20	45	32	25	50	24	18	7,5	45	32	60	6,6	M8
25	58	40	30	61	29	22	8,5	60	40	78	8,4	M10
30	68	47	35	70	34	22	9,5	68	45	87	8,4	M10
40	80	62	45	90	44	26	11	86	58	108	10,5	M12
50	100	75	50	105	49	35	11	108	50	132	13,5	M16

¹⁾ Direction for max. load ratings

²⁾ Picture with non D-series bearing or plain bearing differs

³⁾ For cylinder head screws with internal hexagon according to ISO 4762

LUNR

Designations				Mass kg	Basic load ratings ¹⁾			
LBCR bearing inside with shields		Stainless steel variant of LBCR bearing inside with 2 double lip seals			dynamic C		static C ₀	
-		-		min N		max		
LUNR 12 D ⁿ⁾	LUNR 12 D-2LS ⁿ⁾	LUNR 12 D/HV6 ⁿ⁾	LUNR 12 D-2LS/HV6 ⁿ⁾	0,100	930	1 370	695	1 120
LUNR 16 D ⁿ⁾	LUNR 16 D-2LS ⁿ⁾	LUNR 16 D/HV6 ⁿ⁾	LUNR 16 D-2LS/HV6 ⁿ⁾	0,170	1 080	1 600	800	1 290
LUNR 20 D ⁿ⁾	LUNR 20 D-2LS ⁿ⁾	LUNR 20 D/HV6 ⁿ⁾	LUNR 20 D-2LS/HV6 ⁿ⁾	0,273	2 200	3 250	1 630	2 650
LUNR 25 D ⁿ⁾	LUNR 25 D-2LS ⁿ⁾	LUNR 25 D/HV6 ⁿ⁾	LUNR 25 D-2LS/HV6 ⁿ⁾	0,554	3 100	4 550	2 360	3 800
LUNR 30 D ⁿ⁾	LUNR 30 D-2LS ⁿ⁾	LUNR 30 D/HV6 ⁿ⁾	LUNR 30 D-2LS/HV6 ⁿ⁾	0,827	4 800	7 100	3 550	5 700
LUNR 40 D ⁿ⁾	LUNR 40 D-2LS ⁿ⁾	LUNR 40 D/HV6 ⁿ⁾	LUNR 40 D-2LS/HV6 ⁿ⁾	1,501	7 650	11 200	5 100	8 300
LUNR 50 ⁿ⁾	LUNR 50-2LS ⁿ⁾	LUNR 50/HV6 ⁿ⁾	LUNR 50-2LS/HV6 ⁿ⁾	2,498	9 650	13 400	7 200	12 200

LUND

Designations				Mass kg	Basic load ratings ¹⁾			
Self-aligning LBCD bearing inside with shields		Stainless steel variant of self-aligning LBCD bearing inside with 2 double lip seals			dynamic C		static C ₀	
-		-		min N		max		
LUND 12 D ^{s)}	LUND 12 D-2LS	LUND 12 D/HV6 ⁿ⁾	LUND 12 D-2LS/HV6 ⁿ⁾	0,100	800	1 220	570	930
LUND 16 D ^{s)}	LUND 16 D-2LS	LUND 16D/HV6 ⁿ⁾	LUND 16 D-2LS/HV6 ⁿ⁾	0,169	950	1 400	655	1 060
LUND 20 D ^{s)}	LUND 20 D-2LS	LUND 20D/HV6 ⁿ⁾	LUND 20 D-2LS/HV6 ⁿ⁾	0,272	1 730	2 550	1 120	1 800
LUND 25 D ^{s)}	LUND 25 D-2LS	LUND 25D/HV6 ⁿ⁾	LUND 25 D-2LS/HV6 ⁿ⁾	0,552	2 600	3 800	1 430	2 320
LUND 30 D ^{s)}	LUND 30 D-2LS	LUND 30 D/HV6 ⁿ⁾	LUND 30 D-2LS/HV6 ⁿ⁾	0,825	3 800	5 600	2 320	3 750
LUND 40 D ^{s)}	LUND 40 D-2LS	LUND 40 D/HV6 ⁿ⁾	LUND 40 D-2LS/HV6 ⁿ⁾	1,494	6 550	9 650	3 350	5 700
LUND 50 ^{s)}	LUND 50-2LS	LUND 50/HV6 ⁿ⁾	LUND 50-2LS/HV6 ⁿ⁾	2,478	8 000	11 200	4 150	6 950

LUNR PA

Designations	Mass kg	Basic load ratings		static ²⁾ C ₀
		dynamic C at 0,1 m/s N	at 4 m/s	
LUNR 12 PA ⁿ⁾	0,09	1 060	26	3 650
LUNR 16 PA ⁿ⁾	0,159	1 680	43	5 850
LUNR 20 PA ⁿ⁾	0,245	2 700	68	9 500
LUNR 25 PA ⁿ⁾	0,501	4 400	110	15 300
LUNR 30 PA ⁿ⁾	0,745	6 000	150	20 800
LUNR 40 PA ⁿ⁾	1,358	8 650	216	30 000
LUNR 50 PA ⁿ⁾	2,348	12 700	320	45 000

Items without letter footnote are usually available from stock.

ⁿ⁾ Delivery time on request

^{s)} Delivery time usually 10 days for max. quantity of 4; larger quantities on request

¹⁾ Basic load ratings are valid for bearing steel and stainless steel variants. They must be reduced with stainless steel shafts only

²⁾ Valid if the loads onto the housing are exclusively in direction of red arrow. See dimensional drawing on left page

3.4.6 Standard linear units - LUNS/LUNE

- LUNS with rigid LBCR bearing
- LUNE with self-aligning LBCD bearing
- Slotted design for adjustable clearance in sizes from 12 mm to 50 mm
- Aluminium housing covers the entire bearing length
- Available in variants of 2 seals or 2 shields
- Available as bearing steel (standard) or stainless-steel variant
- Factory pre-lubricated with SKF LGEP 2 grease, ready for use
- Equipped with grease fitting
- Able to bolt from top or bottom side

Please find suitable shaft blocks or shaft supports in **chapter 3.6** and shafts in **chapter 3.7**

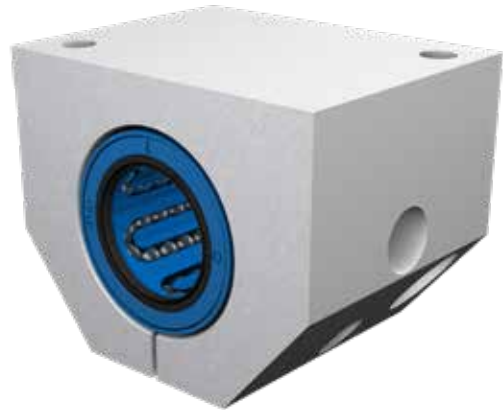

Pictured is LUNE 30 D-2LS ²⁾

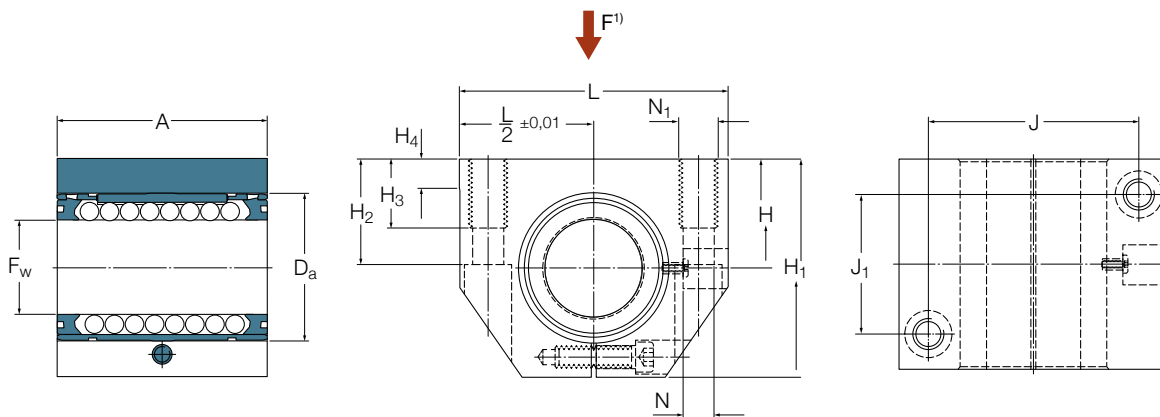

Picture shows LUNE D with shields ²⁾

Dimensions												
F _w	A	D _a	H ±0,01	H ₁	H ₂	H ₃	H ₄	J	J ₁	L	N ³⁾	N ₁
mm												-
12	32	22	18	35	16,5	11	6	32	23	43	4,3	M5
16	37	26	22	42	21	13	7	40	26	53	5,3	M6
20	45	32	25	50	24	18	7,5	45	32	60	6,6	M8
25	58	40	30	61	29	22	8,5	60	40	78	8,4	M10
30	68	47	35	70	34	22	9,5	68	45	87	8,4	M10
40	80	62	45	90	44	26	11	86	58	108	10,5	M12
50	100	75	50	105	49	35	11	108	50	132	13,5	M16

¹⁾ Direction for max. load ratings

²⁾ Picture with non D-series bearing or plain bearing differs

³⁾ For cylinder head screws with internal hexagon according to ISO 4762

LUNS

Designations				Mass kg	Basic load ratings ¹⁾			
LBCR bearing inside with shields		Stainless steel variant of LBCR bearing inside with 2 double lip seals			dynamic C		static C ₀	
–	–	–	–	–	min N	max	min	max
LUNS 12 D ⁿ⁾	LUNS 12 D-2LS ⁿ⁾	LUNS 12 D/HV6 ⁿ⁾	LUNS 12 D-2LS/HV6 ⁿ⁾	0,100	930	1 370	695	1 120
LUNS 16 D ⁿ⁾	LUNS 16 D-2LS ⁿ⁾	LUNS 16 D/HV6 ⁿ⁾	LUNS 16 D-2LS/HV6 ⁿ⁾	0,170	1 080	1 600	800	1 290
LUNS 20 D ⁿ⁾	LUNS 20 D-2LS ⁿ⁾	LUNS 20 D/HV6 ⁿ⁾	LUNS 20 D-2LS/HV6 ⁿ⁾	0,273	2 200	3 250	1 630	2 650
LUNS 25 D ⁿ⁾	LUNS 25 D-2LS ⁿ⁾	LUNS 25 D/HV6 ⁿ⁾	LUNS 25 D-2LS/HV6 ⁿ⁾	0,554	3 100	4 550	2 360	3 800
LUNS 30 D ⁿ⁾	LUNS 30 D-2LS ⁿ⁾	LUNS 30 D/HV6 ⁿ⁾	LUNS 30 D-2LS/HV6 ⁿ⁾	0,827	4 800	7 100	3 550	5 700
LUNS 40 D ⁿ⁾	LUNS 40 D-2LS ⁿ⁾	LUNS 40 D/HV6 ⁿ⁾	LUNS 40 D-2LS/HV6 ⁿ⁾	1,501	7 650	11 200	5 100	8 300
LUNS 50 ⁿ⁾	LUNS 50-2LS ⁿ⁾	LUNS 50/HV6 ⁿ⁾	LUNS 50-2LS/HV6 ⁿ⁾	2,498	9 650	13 400	7 200	12 200

LUNE

Designations				Mass kg	Basic load ratings ¹⁾			
Self-aligning LBCD bearing inside with shields		Stainless steel variant of self-aligning LBCD bearing inside with 2 double lip seals			dynamic C		static C ₀	
–	–	–	–	–	min N	max	min	max
LUNE 12 D ^{s)}	LUNE 12 D-2LS	LUNE 12 D/HV6 ⁿ⁾	LUNE 12 D-2LS/HV6 ⁿ⁾	0,100	800	1 220	570	930
LUNE 16 D ^{s)}	LUNE 16 D-2LS	LUNE 16 D/HV6 ⁿ⁾	LUNE 16 D-2LS/HV6 ⁿ⁾	0,169	950	1 400	655	1 060
LUNE 20 D ^{s)}	LUNE 20 D-2LS	LUNE 20 D/HV6 ⁿ⁾	LUNE 20 D-2LS/HV6 ⁿ⁾	0,272	1 730	2 550	1 120	1 800
LUNE 25 D ^{s)}	LUNE 25 D-2LS	LUNE 25 D/HV6 ⁿ⁾	LUNE 25 D-2LS/HV6 ⁿ⁾	0,552	2 600	3 800	1 430	2 320
LUNE 30 D ^{s)}	LUNE 30 D-2LS	LUNE 30 D/HV6 ⁿ⁾	LUNE 30 D-2LS/HV6 ⁿ⁾	0,825	3 800	5 600	2 320	3 750
LUNE 40 D ^{s)}	LUNE 40 D-2LS	LUNE 40 D/HV6 ⁿ⁾	LUNE 40 D-2LS/HV6 ⁿ⁾	1,494	6 550	9 650	3 350	5 700
LUNE 50 ^{s)}	LUNE 50-2LS	LUNE 50/HV6 ⁿ⁾	LUNE 50-2LS/HV6 ⁿ⁾	2,478	8 000	11 200	4 150	6 950

Items without letter footnote are usually available from stock.

ⁿ⁾ Delivery time on request

^{s)} Delivery time usually 10 days for max. quantity of 4; larger quantities on request

¹⁾ Basic load ratings are valid for bearing steel and stainless steel variants. They must be reduced with stainless steel shafts only

3.4.7 Standard linear units - LUNT/LUNF

- LUNT with rigid LBCT bearing
 - LUNF with self-aligning LBCF bearing
 - LUNT PA with LPAT linear plain bearing
- Open design in sizes from 12 mm to 50 mm
 - Aluminium housing covers the entire bearing length
 - Available in variants of 2 seals or 2 shields
 - Available as bearing steel (standard) or stainless steel variant
 - Factory pre-lubricated with SKF LGEP 2 grease, ready for use
 - Equipped with grease fitting
 - Able to bolt from top or bottom side

Please find suitable shaft blocks or shaft supports in **chapter 3.6** and shafts in **chapter 3.7**

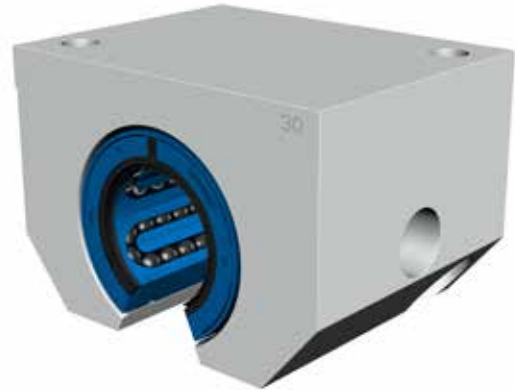

Pictured is LUNF 30 D-2LS ²⁾

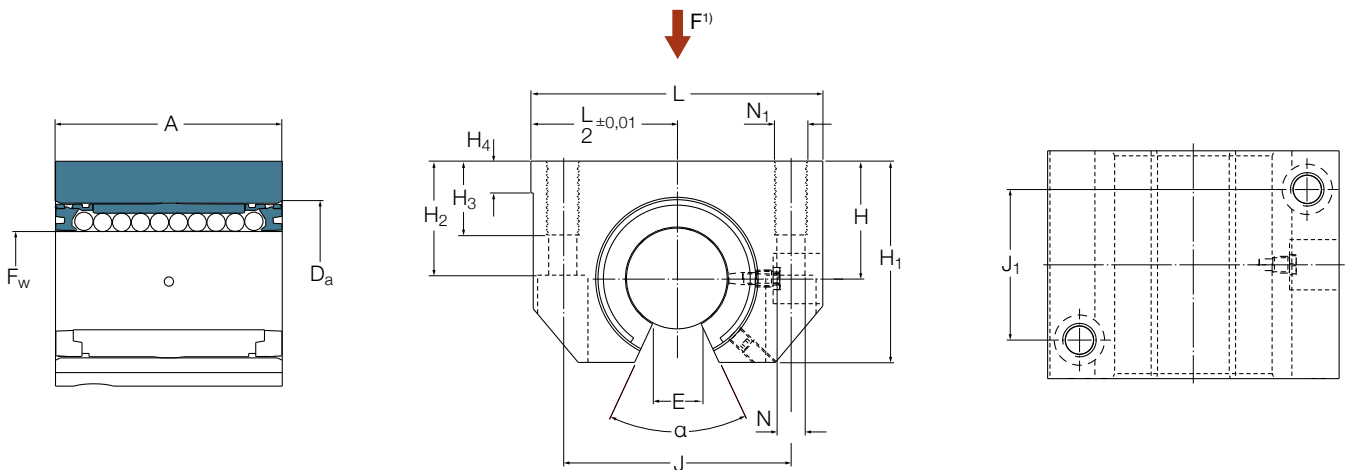

Picture shows LUNF D with shields ²⁾

Dimensions														
F_w	A	D_a	H $\pm 0,01$	H_1	H_2	H_3	H_4	J	J_1	L	$N^{3)}$	N_1	$E^{4)}$	α
mm												-	mm	Deg.
12	32	22	18	28	16,5	11	6	32	23	43	4,3	M5	7,6	78
16	37	26	22	35	21	13	7	40	26	53	5,3	M6	10,4	78
20	45	32	25	42	24	18	7,5	45	32	60	6,6	M8	10,8	60
25	58	40	30	51	29	22	8,5	60	40	78	8,4	M10	13,2	60
30	68	47	35	60	34	22	9,5	68	45	87	8,4	M10	14,2	50
40	80	62	45	77	44	26	11	86	58	108	10,5	M12	18,7	50
50	100	75	50	88	49	35	11	108	50	132	13,5	M16	23,6	50

¹⁾ Direction for max. load ratings

²⁾ Picture with non D-series bearing or plain bearing differs

³⁾ For cylinder head screws with internal hexagon according to ISO 4762

⁴⁾ Minimum sector width at diameter F_w

LUNT

Designations				Mass	Basic load ratings ¹⁾			
LBCT bearing inside with shields		Stainless steel variant of LBCT bearing inside with 2 double lip seals			dynamic C	max	static C ₀	max
-				kg	min		min	
LUNT 12 D ⁿ⁾	LUNT 12 D-2LS ⁿ⁾	LUNT 12 D/HV6 ⁿ⁾	LUNT 12 D-2LS/HV6 ⁿ⁾	0,080	695	1 220	510	1 020
LUNT 16 D ⁿ⁾	LUNT 16 D-2LS ⁿ⁾	LUNT 16 D/HV6 ⁿ⁾	LUNT 16 D-2LS/HV6 ⁿ⁾	0,138	765	1 500	585	1 370
LUNT 20 D ⁿ⁾	LUNT 20 D-2LS ⁿ⁾	LUNT 20 D/HV6 ⁿ⁾	LUNT 20 D-2LS/HV6 ⁿ⁾	0,225	1 860	3 200	1 340	2 700
LUNT 25 D ^{u)}	LUNT 25 D-2LS ^{u)}	LUNT 25 D/HV6 ^{u)}	LUNT 25 D-2LS/HV6 ^{u)}	0,462	2 700	4 650	2 000	4 000
LUNT 30 D ⁿ⁾	LUNT 30 D-2LS ⁿ⁾	LUNT 30 D/HV6 ⁿ⁾	LUNT 30 D-2LS/HV6 ⁿ⁾	0,696	4 150	7 200	3 000	6 000
LUNT 40 D ^{u)}	LUNT 40 D-2LS ^{u)}	LUNT 40 D/HV6 ^{u)}	LUNT 40 D-2LS/HV6 ^{u)}	1,260	6 400	11 000	4 250	8 500
LUNT 50 ⁿ⁾	LUNT 50-2LS ⁿ⁾	LUNT 50/HV6 ⁿ⁾	LUNT 50-2LS/HV6 ⁿ⁾	2,041	5 850	13 400	5 300	12 200

LUNF

Designations				Mass	Basic load ratings ¹⁾			
Self-aligning LBCF bearing inside with shields		Stainless steel variant of self-aligning LBCF bearing inside with 2 double lip seals			dynamic C	max	static C ₀	max
-				kg	min		min	
LUNF 12 D ^{s)}	LUNF 12 D-2LS	LUNF 12 D/HV6 ^{s)}	LUNF 12 D-2LS/HV6 ^{s)}	0,080	600	1 080	415	850
LUNF 16 D ^{s)}	LUNF 16 D-2LS	LUNF 16 D/HV6 ^{s)}	LUNF 16 D-2LS/HV6 ^{s)}	0,138	670	1 320	480	1 120
LUNF 20 D ^{s)}	LUNF 20 D-2LS	LUNF 20 D/HV6 ^{s)}	LUNF 20 D-2LS/HV6 ^{s)}	0,224	1 460	2 500	915	1 830
LUNF 25 D ^{u)}	LUNF 25 D-2LS ^{u)}	LUNF 25 D/HV6 ^{u)}	LUNF 25 D-2LS/HV6 ^{u)}	0,460	2 280	3 900	1 220	2 450
LUNF 30 D ^{s)}	LUNF 30 D-2LS	LUNF 30 D/HV6 ^{s)}	LUNF 30 D-2LS/HV6 ^{s)}	0,694	3 250	5 700	1 960	3 900
LUNF 40 D ^{u)}	LUNF 40 D-2LS ^{u)}	LUNF 40 D/HV6 ^{u)}	LUNF 40 D-2LS/HV6 ^{u)}	1,256	5 500	9 500	3 000	5 850
LUNF 50 ^{s)}	LUNF 50-2LS	LUNF 50/HV6 ^{s)}	LUNF 50-2LS/HV6 ^{s)}	2,021	4 900	11 200	3 000	6 950

LUNT PA

Designations	Mass	Basic load ratings		static ²⁾ C ₀
		dynamic C	at 4 m/s	
LPAT linear plain bearing inside		at 0,1 m/s		
-		kg	N	
LUNT 12 PA ⁿ⁾	0,072	1 060	26	3 650
LUNT 16 PA ⁿ⁾	0,130	1 680	43	5 850
LUNT 20 PA ⁿ⁾	0,202	2 700	68	9 500
LUNT 25 PA ⁿ⁾	0,418	4 400	110	15 300
LUNT 30 PA ⁿ⁾	0,628	6 000	150	20 800
LUNT 40 PA ⁿ⁾	1,143	8 650	216	30 000
LUNT 50 PA ⁿ⁾	1,921	12 700	320	45 000

Items without letter footnote are usually available from stock.

ⁿ⁾ Delivery time on request

^{s)} Delivery time usually 10 days for max. quantity of 4; larger quantities on request

^{u)} Under development, A-series linear ball bearings of that size are available

¹⁾ Basic load ratings are valid for bearing steel and stainless steel variants. They must be reduced with stainless steel shafts only

²⁾ Valid if the loads onto the housing are exclusively in direction of red arrow. See dimensional drawing on left page

3.4.8 Standard flanged units - LVCR/LVCD

- LVCR with rigid LBCR bearing
 - LVCD with self-aligning LBCD bearing
 - LVCR PA with LPAR linear plain bearing
- Flanged design in sizes from 12 mm to 80 mm
 - Cast iron housing for high rigidity
 - Available in variants of 2 seals or 2 shields
 - Available as bearing steel (standard) or stainless-steel variant
 - Factory pre-lubricated with SKF LGEP 2 grease, ready for use
 - Relubrication via the shaft surface
 - Flexible to bolt from either side of the flange surface

Please find suitable shaft blocks or shaft supports in **chapter 3.6** and shafts in **chapter 3.7**



Pictured is LVCR 30 D-2LS ²⁾

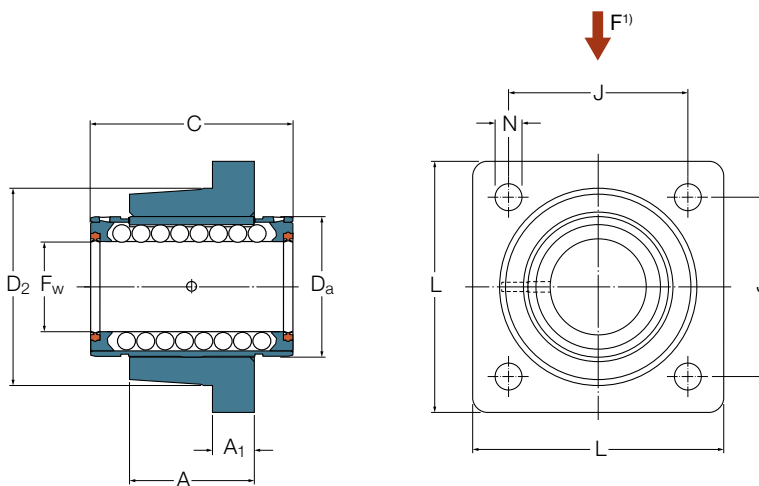

Picture shows LVCR with 2 double lip seals ²⁾

Dimensions								
F _w mm	A	A ₁	C	D _a	D ₂	J	L	N ³⁾
12	20	8	32	22	32	30	42	5,5
16	22	8	36	26	38	35	50	5,5
20	28	10	45	32	46	42	60	6,6
25	40	12	58	40	58	54	74	6,6
30	48	14	68	47	66	60	84	9
40	56	16	80	62	90	78	108	11
50	72	18	100	75	110	98	130	11
60	95	22	125	90	135	120	160	13,5
80	125	25	165	120	180	155	200	13,5

¹⁾ Direction for max. load ratings

²⁾ Picture with non D-series bearing or plain bearing differs

³⁾ For cylinder head screws with internal hexagon according to ISO 4762

LVCR

Designations			Mass	Basic load ratings ¹⁾			
LBCR bearing inside with shields	with 2 double lip seals	Stainless steel variant of LBCR bearing inside with 2 double lip seals		dynamic C	max	static C ₀	max
–			kg	min N		min	
LVCR 12 D ^{s)}	LVCR 12 D-2LS	LVCR 12 D-2LS/HV6 ⁿ⁾	0,117	930	1 370	695	1 120
LVCR 16 D ^{s)}	LVCR 16 D-2LS	LVCR 16 D-2LS/HV6 ⁿ⁾	0,171	1 080	1 600	800	1 290
LVCR 20 D ^{s)}	LVCR 20 D-2LS	LVCR 20 D-2LS/HV6 ⁿ⁾	0,326	2 200	3 250	1 630	2 650
LVCR 25 D ^{s)}	LVCR 25 D-2LS	LVCR 25 D-2LS/HV6 ⁿ⁾	0,676	3 100	4 550	2 360	3 800
LVCR 30 D ^{s)}	LVCR 30 D-2LS	LVCR 30 D-2LS/HV6 ⁿ⁾	1,032	4 800	7 100	3 550	5 700
LVCR 40 D ^{s)}	LVCR 40 D-2LS	LVCR 40 D-2LS/HV6 ⁿ⁾	1,973	7 650	11 200	5 100	8 300
LVCR 50 ^{s)}	LVCR 50-2LS	LVCR 50-2LS/HV6 ⁿ⁾	3,294	9 650	13 400	7 200	12 200
LVCR 60 ^{s)}	LVCR 60-2LS ^{s)}	LVCR 60-2LS/HV6 ⁿ⁾	5,920	14 600	20 400	11 200	18 000
LVCR 80 ^{s)}	LVCR 80-2LS ^{s)}	LVCR 80-2LS/HV6 ⁿ⁾	13,300	26 500	37 500	19 600	32 000

LVCD

Designations			Mass	Basic load ratings ¹⁾			
Self-aligning LBCD bearing inside with shields	with 2 double lip seals	Stainless steel variant of self-aligning LBCD bearing inside with 2 double lip seals		dynamic C	max	static C ₀	max
–			kg	min N		min	
LVCD 12 D ⁿ⁾	LVCD 12 D-2LS ^{s)}	LVCD 12 D-2LS/HV6 ⁿ⁾	0,117	800	1 220	570	930
LVCD 16 D ⁿ⁾	LVCD 16 D-2LS ^{s)}	LVCD 16 D-2LS/HV6 ⁿ⁾	0,170	950	1 400	655	1 060
LVCD 20 D ⁿ⁾	LVCD 20 D-2LS ^{s)}	LVCD 20 D-2LS/HV6 ⁿ⁾	0,325	1 730	2 550	1 120	1 800
LVCD 25 D ⁿ⁾	LVCD 25 D-2LS ^{s)}	LVCD 25 D-2LS/HV6 ⁿ⁾	0,674	2 600	3 800	1 430	2 320
LVCD 30 D ⁿ⁾	LVCD 30 D-2LS ^{s)}	LVCD 30 D-2LS/HV6 ⁿ⁾	1,030	3 800	5 600	2 320	3 750
LVCD 40 D ⁿ⁾	LVCD 40 D-2LS ^{s)}	LVCD 40 D-2LS/HV6 ⁿ⁾	1,966	6 550	9 650	3 350	5 700
LVCD 50 ⁿ⁾	LVCD 50-2LS ^{s)}	LVCD 50 2LS/HV6 ⁿ⁾	3,274	8 000	11 200	4 150	6 950

LVCR PA

Designations	Mass	Basic load ratings		static ²⁾ C ₀
		dynamic C at 0,1 m/s N	at 4 m/s	
–	kg			
LVCR 12 PA ⁿ⁾	0,107	1 060	26	3 650
LVCR 16 PA ⁿ⁾	0,160	1 680	43	5 850
LVCR 20 PA ⁿ⁾	0,298	2 700	68	9 500
LVCR 25 PA ⁿ⁾	0,623	4 400	110	15 300
LVCR 30 PA ⁿ⁾	0,950	6 000	150	20 800
LVCR 40 PA ⁿ⁾	1,830	8 650	216	30 000
LVCR 50 PA ⁿ⁾	3,144	12 700	320	45 000
LVCR 60 PA ⁿ⁾	5,660	19 300	480	67 000
LVCR 80 PA ⁿ⁾	12,720	33 500	830	116 000

Items without letter footnote are usually available from stock.

ⁿ⁾ Delivery time on request

^{s)} Delivery time usually 10 days for max. quantity of 4; larger quantities on request

¹⁾ Basic load ratings are valid for bearing steel and stainless steel variants. They must be reduced with stainless steel shafts only

²⁾ Valid if the loads onto the housing are exclusively in direction of red arrow. See dimensional drawing on left page

3.4.9 Standard tandem units - LTCR/LTCD

- LTCR with rigid LBCR bearing
 - LTCD with self-aligning LBCD bearing
 - LTCR PA with LPAR linear plain bearing
- Closed design in sizes from 12 mm to 50 mm
 - Aluminium housing with 2 mounted bearings
 - Available as sealed or shielded variant
 - Available as bearing steel (standard) or stainless steel variant
 - Factory pre-lubricated with SKF LGEP 2 grease, ready for use
 - Equipped with grease fitting
 - Able to bolt from top or bottom side

Please find suitable shaft blocks or shaft supports in **chapter 3.6** and shafts in **chapter 3.7**

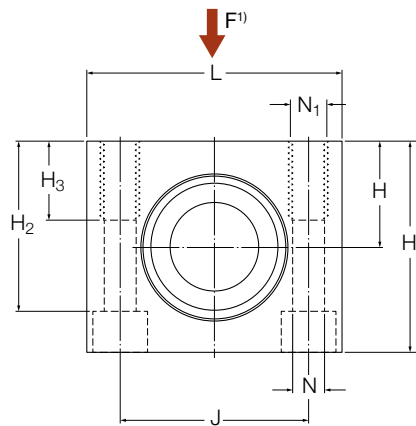
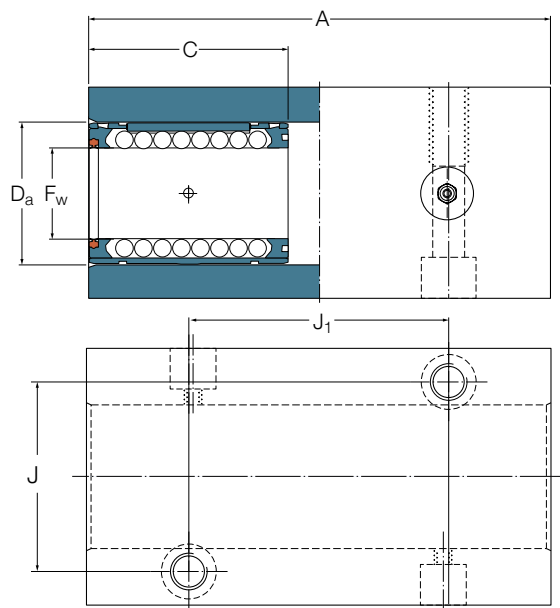

Pictured is LTCD 30 D-2LS ²⁾

Picture shows LTCD D with double lip seals on the outside ²⁾

Dimensions												
F _w	A	C	D _a	H ±0,01	H ₁	H ₂	H ₃	J	J ₁	L	N ³⁾	N ₁
mm												-
12	76	32	22	18	35	27	13	30	40	42	5,3	M6
16	84	36	26	22	41,5	33,0	13	36	45	50	5,3	M6
20	104	45	32	25	49,5	39,5	18	45	55	60	6,4	M8
25	130	58	40	30	59,5	47	22	54	70	74	8,4	M10
30	152	68	47	35	69,5	55	26	62	85	84	10,5	M12
40	176	80	62	45	89,5	71	34	80	100	108	13	M16
50	224	100	75	50	99,5	81	34	100	125	130	13	M16

¹⁾ Direction for max. load ratings

²⁾ Picture with non D-series bearing or plain bearing differs

³⁾ For 2 cylinder head screws with internal hexagon according to ISO 4762

LTCR

Designations			Mass kg	Basic load ratings ¹⁾			
LBCR bearing inside with shields	with double lip seal	Stainless steel variant of LBCR bearing inside with double lip seal		dynamic C min N	max	static C ₀ min	max
–							
LTCD 12 D ⁿ⁾	LTCD 12 D-2LS ^{s)}	LTCD 12 D-2LS/HV6 ⁿ⁾	0,248	1 500	2 240	1 400	2 240
LTCD 16 D ⁿ⁾	LTCD 16 D-2LS ^{s)}	LTCD 16 D-2LS/HV6 ⁿ⁾	0,387	1 760	2 600	1 600	2 600
LTCD 20 D ⁿ⁾	LTCD 20 D-2LS ^{s)}	LTCD 20 D-2LS/HV6 ⁿ⁾	0,696	3 550	5 300	3 250	5 300
LTCD 25 D ⁿ⁾	LTCD 25 D-2LS ^{s)}	LTCD 25 D-2LS/HV6 ⁿ⁾	1,282	5 000	7 350	4 750	7 650
LTCD 30 D ⁿ⁾	LTCD 30 D-2LS ^{s)}	LTCD 30 D-2LS/HV6 ⁿ⁾	1,942	7 800	11 600	7 100	11 400
LTCD 40 D ⁿ⁾	LTCD 40 D-2LS ^{s)}	LTCD 40 D-2LS/HV6 ⁿ⁾	3,683	12 500	18 300	10 200	16 600
LTCD 50 ⁿ⁾	LTCD 50-2LS ^{s)}	LTCD 50-2LS/HV6 ⁿ⁾	5,970	15 600	21 600	14 300	24 500

LTCD

Designations			Mass kg	Basic load ratings ¹⁾			
Self-aligning LBCD bearing inside with shields	with double lip seal	Stainless steel variant of self-aligning LBCD bearing inside with double lip seal		dynamic C min N	max	static C ₀ min	max
–							
LTCD 12 D ⁿ⁾	LTCD 12 D-2LS ^{s)}	LTCD 12 D-2LS/HV6 ⁿ⁾	0,248	1 290	2 000	1 140	1 860
LTCD 16 D ⁿ⁾	LTCD 16 D-2LS ^{s)}	LTCD 16 D-2LS/HV6 ⁿ⁾	0,385	1 530	2 280	1 320	2 120
LTCD 20 D ⁿ⁾	LTCD 20 D-2LS ^{s)}	LTCD 20 D-2LS/HV6 ⁿ⁾	0,694	2 800	4 150	2 240	3 600
LTCD 25 D ⁿ⁾	LTCD 25 D-2LS ^{s)}	LTCD 25 D-2LS/HV6 ⁿ⁾	1,278	4 250	6 200	2 850	4 650
LTCD 30 D ⁿ⁾	LTCD 30 D-2LS ^{s)}	LTCD 30 D-2LS/HV6 ⁿ⁾	1,938	6 200	9 150	4 650	7 500
LTCD 40 D ⁿ⁾	LTCD 40 D-2LS ^{s)}	LTCD 40 D-2LS/HV6 ⁿ⁾	3,669	10 600	15 600	6 700	11 400
LTCD 50 ⁿ⁾	LTCD 50-2LS ^{s)}	LTCD 50-2LS/HV6 ⁿ⁾	5,930	12 900	18 300	8 300	14 000

LTCD PA

Designations	Mass kg	Basic load ratings		static ²⁾ C ₀
		dynamic C at 0,1 m/s N	at 4 m/s	
–				
LTCD 12 PA ⁿ⁾	0,228	2 120	52	7 300
LTCD 16 PA ⁿ⁾	0,365	3 360	86	11 700
LTCD 20 PA ⁿ⁾	0,640	5 400	136	19 000
LTCD 25 PA ⁿ⁾	1,176	8 800	220	30 600
LTCD 30 PA ⁿ⁾	1,778	12 000	300	41 600
LTCD 40 PA ⁿ⁾	3,397	17 300	432	60 000
LTCD 50 PA ⁿ⁾	5,670	25 400	640	90 000

ⁿ⁾ Delivery time on request

^{s)} Delivery time usually 10 days for max. quantity of 4; larger quantities on request

¹⁾ Basic load ratings are valid for bearing steel and stainless steel variants. They must be reduced with stainless steel shafts only

²⁾ Valid if the loads onto the housing are exclusively in direction of red arrow. See dimensional drawing on left page

3.4.10 Standard tandem units - LTCT/LTCF

- LTCT with rigid LBCT bearing
 - LTCF with self-aligning LBCF bearing
 - LTCT PA with LPAT linear plain bearing
- Open design in sizes from 12 mm to 50 mm
 - Aluminium housing with 2 mounted bearings
 - Available as sealed or shielded variant
 - Available as bearing steel (standard) or stainless steel variant
 - Factory pre-lubricated with SKF LGEP 2 grease, ready for use
 - Equipped with grease fitting
 - Able to bolt from top or bottom side

Please find suitable shaft blocks or shaft supports in **chapter 3.6** and shafts in **chapter 3.7**



Pictured is LTCF 30 D-2LS ²⁾

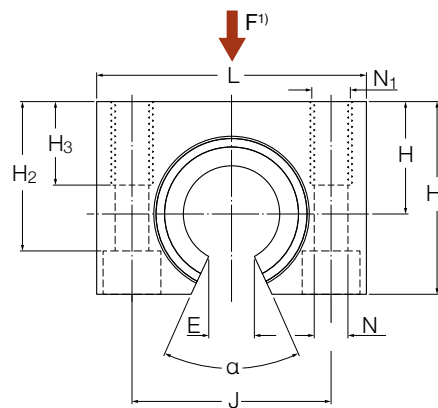
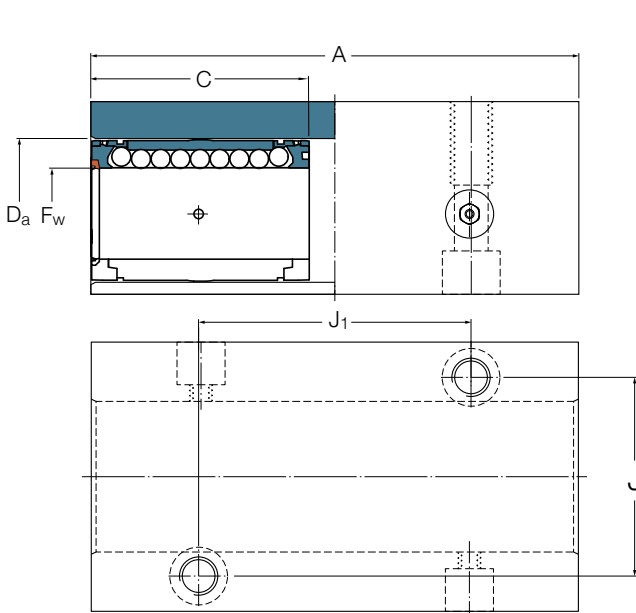

Picture shows LTCF D with double lip seals on the outside ²⁾

Dimensions

F _w mm	A	C	D _a	H	H ₁	H ₂	H ₃	J	J ₁	L	N ³⁾	N ₁ -	E ⁴⁾ mm	α Deg.
12	76	32	22	18	29	23,5	13	30	40	42	5,3	M6	7,6	78
16	84	36	26	22	35	28	13	36	45	50	5,3	M6	10,4	78
20	104	45	32	25	42	33,5	18	45	55	60	6,4	M8	10,8	60
25	130	58	40	30	51	40	22	54	70	74	8,4	M10	13,2	60
30	152	68	47	35	60	46,5	26	62	85	84	10,5	M12	14,2	50
40	176	80	62	45	77	61	34	80	100	108	13	M16	18,7	50
50	224	100	75	50	88	72	34	100	125	130	13	M16	23,6	50

¹⁾ Direction for max. load ratings

²⁾ Picture with non D-series bearing or plain bearing differs

³⁾ For cylinder head screws with internal hexagon according to ISO 4762

⁴⁾ Minimum sector width at diameter F_w

LTCT

Designations			Mass kg	Basic load ratings ¹⁾			
LBCT bearing inside with shields	with double lip seal	Stainless steel variant of LBCT bearing inside with double lip seal		dynamic C min N	max	static C ₀ min	max
–							
LTCT 12 D ⁿ⁾	LTCT 12 D-2LS ⁿ⁾	LTCT 12 D-2LS/HV6 ⁿ⁾	0,189	1 120	2 000	1 020	2 040
LTCT 16 D ⁿ⁾	LTCT 16 D-2LS ⁿ⁾	LTCT 16 D-2LS/HV6 ⁿ⁾	0,296	1 250	2 450	1 180	2 750
LTCT 20 D ⁿ⁾	LTCT 20 D-2LS ⁿ⁾	LTCT 20 D-2LS/HV6 ⁿ⁾	0,646	3 000	5 200	2 700	5 400
LTCT 25 D ^{u)}	LTCT 25 D-2LS ^{u)}	LTCT 25 D-2LS/HV6 ^{u)}	1,004	4 400	7 500	4 000	8 000
LTCT 30 D ⁿ⁾	LTCT 30 D-2LS ⁿ⁾	LTCT 30 D-2LS/HV6 ⁿ⁾	1,548	6 700	11 600	6 000	12 000
LTCT 40 D ^{u)}	LTCT 40 D-2LS ^{u)}	LTCT 40 D-2LS/HV6 ^{u)}	2,918	10 400	18 000	8 500	17 000
LTCT 50 ⁿ⁾	LTCT 50-2LS ⁿ⁾	LTCT 50-2LS/HV6 ⁿ⁾	4,880	9 500	21 600	10 600	24 500

LTCF

Designations			Mass kg	Basic load ratings ¹⁾			
Self-aligning LBCF bearing inside with shields	with double lip seal	Stainless steel variant of self-aligning LBCF bearing inside with double lip seal		dynamic C min N	max	static C ₀ min	max
–							
LTCF 12 D ⁿ⁾	LTCF 12 D-2LS ^{s)}	LTCF 12 D-2LS/HV6 ⁿ⁾	0,189	980	1 760	830	1 700
LTCF 16 D ⁿ⁾	LTCF 16 D-2LS ^{s)}	LTCF 16 D-2LS/HV6 ⁿ⁾	0,296	1 080	2 160	965	2 240
LTCF 20 D ⁿ⁾	LTCF 20 D-2LS ^{s)}	LTCF 20 D-2LS/HV6 ⁿ⁾	0,644	2 360	4 050	1 830	3 660
LTCF 25 D ^{u)}	LTCF 25 D-2LS ^{u)}	LTCF 25 D-2LS/HV6 ^{u)}	1,000	3 750	6 300	2 450	4 900
LTCF 30 D ⁿ⁾	LTCF 30 D-2LS ^{s)}	LTCF 30 D-2LS/HV6 ⁿ⁾	1,544	5 300	9 300	3 900	7 800
LTCF 40 D ^{u)}	LTCF 40 D-2LS ^{u)}	LTCF 40 D-2LS/HV6 ^{u)}	2,910	9 000	15 300	6 000	11 800
LTCF 50 ⁿ⁾	LTCF 50-2LS ^{s)}	LTCF 50-2LS/HV6 ⁿ⁾	4,840	8 000	18 300	6 000	14 000

LTCT PA

Designations	Mass kg	Basic load ratings		static ²⁾ C ₀
		dynamic C at 0,1 m/s N	at 4 m/s	
LPAT linear plain bearing inside				
–				
LTCT 12 PA ⁿ⁾	0,173	2 120	52	7 300
LTCT 16 PA ⁿ⁾	0,280	3 360	86	117 00
LTCT 20 PA ⁿ⁾	0,600	5 400	136	19 000
LTCT 25 PA ⁿ⁾	0,916	8 800	220	30 600
LTCT 30 PA ⁿ⁾	1,412	12 000	300	41 600
LTCT 40 PA ⁿ⁾	2,684	17 300	432	60 000
LTCT 50 PA ⁿ⁾	4,640	25 400	640	90 000

ⁿ⁾ Delivery time on request

^{s)} Delivery time usually 10 days for max. quantity of 4; larger quantities on request

^{u)} Under development, A-series linear ball bearings of that size are available

¹⁾ Basic load ratings are valid for bearing steel and stainless steel variants. They must be reduced with stainless steel shafts only

²⁾ Valid if the loads onto the housing are exclusively in direction of red arrow. See dimensional drawing on left page

3.4.11 Standard quadro units - LQCR/LQCD

- LQCR with rigid LBCR bearing
 - LQCD with self-aligning LBCD bearing
 - LQCR PA with LPAR linear plain bearing
- Closed design in sizes from 8 mm to 50 mm
 - Aluminium housing with 4 mounted bearings
 - Available as sealed or shielded variant
 - Available as bearing steel (standard) or stainless steel variant
 - Factory pre-lubricated with SKF LGEP 2 grease, ready for use
 - Equipped with grease fitting
 - Able to bolt from top or bottom side



Please find suitable shaft blocks or shaft supports in **chapter 3.6** and shafts in **chapter 3.7**

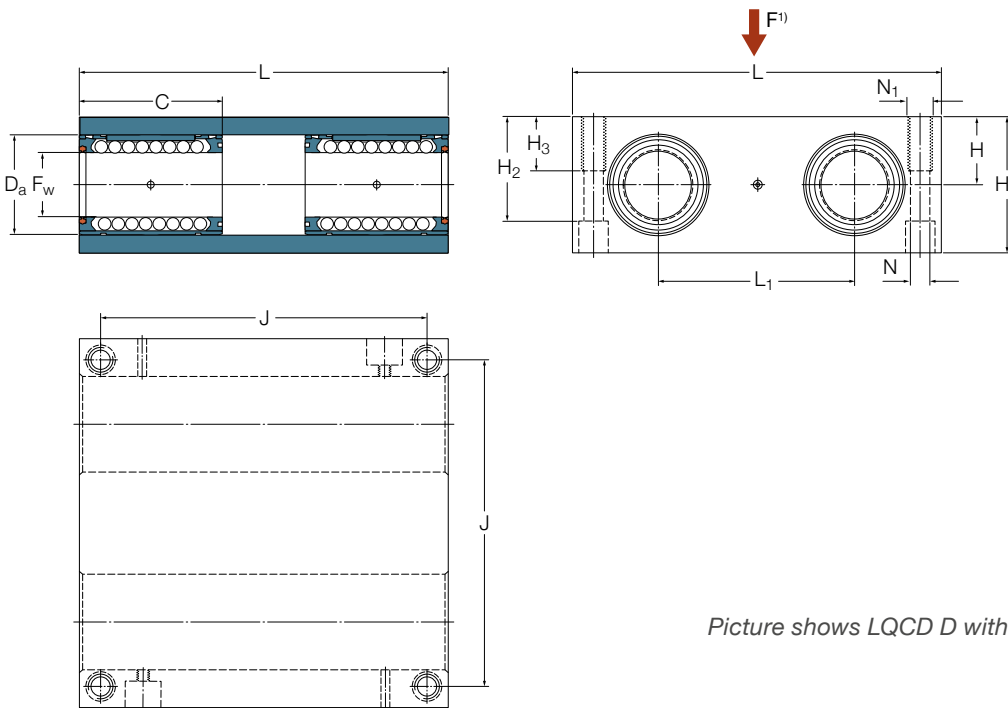

Pictured is LQCD 30 D-2LS ²⁾

Picture shows LQCD D with double lip seals on the outside ²⁾

Dimensions

F_w	C	D_a	$H \pm 0,01$	H_1	H_2	H_3	J	L	L_1	$N^{3)}$	N_1
mm											-
8	25	16	11,5	23	17,5	11	55	65	32	4,3	M5
12	32	22	16	32	25	13	73	85	42	5,3	M6
16	36	26	18	36	29	13	88	100	54	5,3	M6
20	45	32	23	46	37,5	18	115	130	72	6,6	M8
25	58	40	28	56	45	22	140	160	88	8,4	M10
30	68	47	32	64	50,5	26	158	180	96	10,5	M12
40	80	62	40	80	64	34	202	230	122	13,5	M16
50	100	75	48	96	80	34	250	280	152	13,5	M16

¹⁾ Direction for max. load ratings

²⁾ Picture with non D-series bearing or plain bearing differs

³⁾ For 4 cylinder head screws with internal hexagon according to ISO 4762

LQCR

Designations			Mass	Basic load ratings ¹⁾			
LQCR bearing inside with shields	with double lip seal	Stainless steel variant of LQCR bearing with double lip seal		dynamic C	max	static C ₀	max
–			kg	min N		min	
LQCR 8 ^{2) n)}	LQCR 8-2LS ^{2) n)}	LQCR 8-2LS/HV6 ^{2) n)}	0,219	1 290	1 500	1 430	2 000
LQCR 12 D ⁿ⁾	LQCR 12 D-2LS ⁿ⁾	LQCR 12 D-2LS/HV6 ⁿ⁾	0,513	2 450	3 600	2 800	4 500
LQCR 16 D ⁿ⁾	LQCR 16 D-2LS ⁿ⁾	LQCR 16 D-2LS/HV6 ⁿ⁾	0,768	2 850	4 250	3 200	5 200
LQCR 20 D ⁿ⁾	LQCR 20 D-2LS ⁿ⁾	LQCR 20 D-2LS/HV6 ⁿ⁾	1,731	5 850	8 650	6 550	10 600
LQCR 25 D ⁿ⁾	LQCR 25 D-2LS ⁿ⁾	LQCR 25 D-2LS/HV6 ⁿ⁾	3,112	8 150	12 000	9 500	15 300
LQCR 30 D ⁿ⁾	LQCR 30 D-2LS ⁿ⁾	LQCR 30 D-2LS/HV6 ⁿ⁾	4,419	12 700	18 600	14 300	22 800
LQCR 40 D ⁿ⁾	LQCR 40 D-2LS ⁿ⁾	LQCR 40 D-2LS/HV6 ⁿ⁾	8,642	20 000	30 000	20 400	33 500
LQCR 50 ⁿ⁾	LQCR 50-2LS ⁿ⁾	LQCR 50-2LS/HV6 ⁿ⁾	15,090	25 500	35 500	29 000	49 000

LQCD

Designations			Mass	Basic load ratings ¹⁾			
Self-aligning LQCD bearing inside with shields	with double lip seal	Stainless steel variant of self-aligning LQCD bearing inside with double lip seal		dynamic C	max	static C ₀	max
–			kg	min N		min	
LQCD 12 D ⁿ⁾	LQCD 12 D-2LS	LQCD 12 D-2LS/HV6 ⁿ⁾	0,513	2 120	3 200	2 280	3 750
LQCD 16 D ⁿ⁾	LQCD 16 D-2LS	LQCD 16 D-2LS/HV6 ⁿ⁾	0,764	2 500	3 650	2 600	4 250
LQCD 20 D ⁿ⁾	LQCD 20 D-2LS	LQCD 20 D-2LS/HV6 ⁿ⁾	1,727	4 550	6 700	4 500	7 200
LQCD 25 D ⁿ⁾	LQCD 25 D-2LS	LQCD 25 D-2LS/HV6 ⁿ⁾	3,104	6 800	10 000	5 700	9 300
LQCD 30 D ⁿ⁾	LQCD 30 D-2LS	LQCD 30 D-2LS/HV6 ⁿ⁾	4,411	10 000	14 600	9 300	15 000
LQCD 40 D ⁿ⁾	LQCD 40 D-2LS	LQCD 40 D-2LS/HV6 ⁿ⁾	8,614	17 300	25 500	13 400	22 800
LQCD 50 ⁿ⁾	LQCD 50-2LS	LQCD 50-2LS/HV6 ⁿ⁾	15,010	2 1200	30 000	16 600	28 000

LQCR PA

Designations	Mass	Basic load ratings		static ³⁾ C ₀
LQCR linear plain bearing inside		dynamic C		
–	kg	at 0,1 m/s N	at 4 m/s	
LQCR 8 PA ⁿ⁾	0,203	2 280	56	8 000
LQCR 12 PA ⁿ⁾	0,473	4 240	104	14 600
LQCR 16 PA ⁿ⁾	0,724	6 720	172	23 400
LQCR 20 PA ⁿ⁾	1,619	10 800	272	38 000
LQCR 25 PA ⁿ⁾	2,900	17 600	440	61 200
LQCR 30 PA ⁿ⁾	4,091	24 000	600	83 200
LQCR 40 PA ⁿ⁾	8,070	34 600	864	120 000
LQCR 50 PA ⁿ⁾	14,490	50 800	1 280	180 000

Items without letter footnote are usually available from stock.

ⁿ⁾ Delivery time on request

¹⁾ Delivery time usually 10 days for max. quantity of 4; larger quantities on request

¹⁾ Basic load ratings are valid for bearing steel and stainless steel variants. They must be reduced with stainless steel shafts only

²⁾ Units in size 8 mm are without relubrication

³⁾ Valid if the loads onto the housing are exclusively in direction of red arrow. See dimensional drawing on left page

3.4.12 Standard quadro units - LQCT/LQCF

- LQCT with rigid LBCT bearing
 - LQCF with self-aligning LBCF bearing
 - LQCT PA with LPAT linear plain bearing
- Open design in sizes from 12 mm to 50 mm
 - Aluminium housing with 4 mounted bearings
 - Available as sealed or shielded variant
 - Available as bearing steel (standard) or stainless steel variant
 - Factory pre-lubricated with SKF LGEP 2 grease, ready for use
 - Equipped with grease fitting
 - Able to bolt from top or bottom side



Please find suitable shaft blocks or shaft supports in **chapter 3.6** and shafts in **chapter 3.7**

Pictured is LQCF 30 D-2LS ²⁾

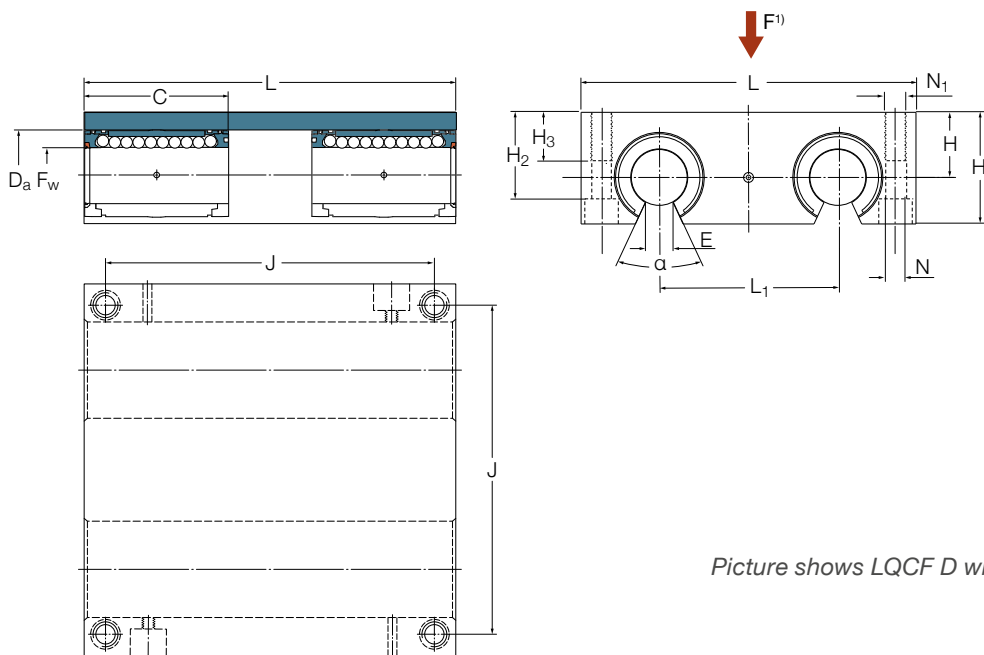

Picture shows LQCF D with double lip seals on the outside ²⁾

Dimensions

F_w	C	D_a	$H \pm 0,01$	H_1	H_2	H_3	J	L	L_1	$N^{3)}$	N_1	$E^{4)}$	α
mm											-	mm	Deg.
12	32	22	18	30	23,4	13	73	85	42	5,3	M6	7,6	78
16	36	26	22	35	28,4	13	88	100	54	5,3	M6	10,4	78
20	45	32	25	42	33,5	18	115	130	72	6,6	M8	10,8	60
25	58	40	30	51	40	22	140	160	88	8,4	M10	13,2	60
30	68	47	35	60	46,5	26	158	180	96	10,5	M12	14,2	50
40	80	62	45	77	61	34	202	230	122	13,5	M16	18,7	50
50	100	75	55	93	77	34	250	280	152	13,5	M16	23,6	50

¹⁾ Direction for max. load ratings

²⁾ Picture with non D-series bearing or plain bearing differs

³⁾ For cylinder head screws with internal hexagon according to ISO 4762

⁴⁾ Minimum sector width at diameter F_w

LQCT

Designations			Mass kg	Basic load ratings ¹⁾			
LBCT bearing inside with shields	with double lip seal	Stainless steel variant of LBCT bearing inside with double lip seal		dynamic C min N	max	static C ₀ min	max
–	–	–	–	–	–	–	–
LQCT 12 D ⁿ⁾	LQCT 12 D-2LS ⁿ⁾	LQCT 12 D-2LS/HV6 ⁿ⁾	0,444	1 830	3 200	2 040	4 050
LQCT 16 D ⁿ⁾	LQCT 16 D-2LS ⁿ⁾	LQCT 16 D-2LS/HV6 ⁿ⁾	0,710	2 000	4 000	2 360	5 500
LQCT 20 D ⁿ⁾	LQCT 20 D-2LS ⁿ⁾	LQCT 20 D-2LS/HV6 ⁿ⁾	1,458	4 900	8 500	5 400	10 800
LQCT 25 D ^{u)}	LQCT 25 D-2LS ^{u)}	LQCT 25 D-2LS/HV6 ^{u)}	2,654	7 100	12 200	8 000	16 000
LQCT 30 D ⁿ⁾	LQCT 30 D-2LS ⁿ⁾	LQCT 30 D-2LS/HV6 ⁿ⁾	3,918	11 000	19 000	12 000	24 000
LQCT 40 D ^{u)}	LQCT 40 D-2LS ^{u)}	LQCT 40 D-2LS/HV6 ^{u)}	8,078	17 000	29 000	17 000	34 000
LQCT 50 ⁿ⁾	LQCT 50-2LS ⁿ⁾	LQCT 50-2LS/HV6 ⁿ⁾	14,060	15 300	35 500	21 200	49 000

LQCF

Designations			Mass kg	Basic load ratings ¹⁾			
Self-aligning LBCF bearing inside with shields	with double lip seal	Stainless steel variant of self-aligning LBCF bearing inside with double lip seal		dynamic C min N	max	static C ₀ min	max
–	–	–	–	–	–	–	–
LQCF 12 D ⁿ⁾	LQCF 12 D-2LS ^{s)}	LQCF 12 D-2LS/HV6 ⁿ⁾	0,444	1 600	2 850	1 660	3 400
LQCF 16 D ⁿ⁾	LQCF 16 D-2LS ^{s)}	LQCF 16 D-2LS/HV6 ⁿ⁾	0,71	1 760	3 450	1 930	4 500
LQCF 20 D ⁿ⁾	LQCF 20 D-2LS ^{s)}	LQCF 20 D-2LS/HV6 ⁿ⁾	1,454	3 900	6 550	3 650	7 350
LQCF 25 D ^{u)}	LQCF 25 D-2LS ^{u)}	LQCF 25 D-2LS/HV6 ^{u)}	2,646	6 000	10 200	4 900	9 800
LQCF 30 D ⁿ⁾	LQCF 30 D-2LS ^{s)}	LQCF 30 D-2LS/HV6 ⁿ⁾	3,91	8 650	15 000	7 800	15 600
LQCF 40 D ^{u)}	LQCF 40 D-2LS ^{u)}	LQCF 40 D-2LS/HV6 ^{u)}	8,062	14 600	25 000	12 000	23 600
LQCF 50 ⁿ⁾	LQCF 50-2LS ^{s)}	LQCF 50-2LS/HV6 ⁿ⁾	13,98	12 900	30 000	12 000	28 000

LQCT PA

Designations	Mass kg	Basic load ratings		static ²⁾ C ₀
		dynamic C at 0,1 m/s N	at 4 m/s	
LPAT linear plain bearing inside	–	–	–	–
LQCT 12 PA ⁿ⁾	0,412	4 240	104	14 600
LQCT 16 PA ⁿ⁾	0,678	6 720	172	23 400
LQCT 20 PA ⁿ⁾	1,366	10 800	272	38 000
LQCT 25 PA ⁿ⁾	2,478	17 600	440	61 200
LQCT 30 PA ⁿ⁾	3,646	24 000	600	83 200
LQCT 40 PA ⁿ⁾	7,610	34 600	864	120 000
LQCT 50 PA ⁿ⁾	13,580	50 800	1 280	180 000

ⁿ⁾ Delivery time on request^{s)} Delivery time usually 10 days for max. quantity of 4; larger quantities on request^{u)} Under development, A-series linear ball bearings of that size are available¹⁾ Basic load ratings are valid for bearing steel and stainless steel variant. They must be reduced with stainless steel shafts only²⁾ Valid if the loads onto the housing are exclusively in direction of red arrow. See dimensional drawing on left page

3.5 Standard housings

Linear ball bearing must be mounted into housing for proper usage. It is more user friendly to use linear ball bearing units mentioned in the previous chapters, but for flexible use, Ewellix is offering their lightweight aluminium housing range as a component. The housings are ready machined to be equipped with Ewellix standard bearings. The high quality

design has a defined reference side for linear alignment. It offers flexible installation and bolting possibilities depending on the application. The axial and radial bearing fixation is made for standard ISO bearings. With each housing Ewellix delivers a grease fitting for the bearing fixation. Three types of housing variants are available.

LHCR



Lightweight linear bearing housing in closed design. Available in sizes from 8 mm to 80 mm for standard bearings. Easy to bolt from top or bottom surface, with a reference side for linear alignment. Made for bearing fixation via grease fitting for lubrication, except in size 8 mm.

LHCS



Lightweight linear bearing housing in slotted design for adjustable clearance. Available in sizes from 8 mm to 80 mm for standard bearings. Easy to bolt from top or bottom surface, with a reference side for linear alignment. Made for bearing fixation via grease fitting for lubrication, except in size 8 mm.

LHCT



Lightweight linear bearing housing in open design. Available in sizes from 12 mm to 80 mm for standard bearings. Easy to bolt from top or bottom surface, with a reference side for linear alignment. Made for bearing fixation via grease fitting for lubrication.

3.5.1 Standard housings - LHCR/LHCS

- LHCR in closed design
- LHCS in slotted design for adjustable clearance

- Closed and slotted design in sizes from 8 mm to 80 mm
- Lightweight die-cast aluminium housing
- Able to bolt from top or bottom side
- With reference side for linear alignment
- Supplied with grease fitting for lubrication and axial bearing fixation



Pictured is LHCR 30

Pictured is LHCS 30

Please find suitable shaft blocks or shaft supports in **chapter 3.6** and shafts in **chapter 3.7**

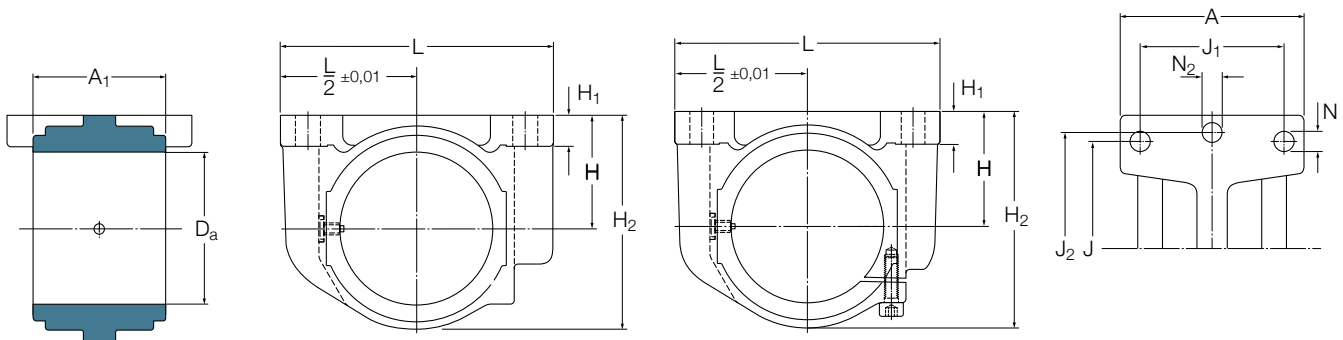

Dimensions

D_a Tolerance J6 mm	A	A_1	H $\pm 0,01$	H_1	H_2	J	J_1	J_2	$L^{1)}$	$N^{2)}$	$N_2^{2)}$
16	27	14	15	5,5	28	25	20	35	45	3,2	5,3
22	31	20	18	6	34,5	32	23	42	52	4,3	5,3
26	35	22	22	7	40,5	40	26	46	56	4,3	5,3
32	41	28	25	8	48	45	32	58	70	4,3	6,4
40	52	40	30	10	58	60	40	68	80	5,3	6,4
47	59	48	35	10	67	68	45	76	88	6,4	6,4
62	74	56	45	12	85	86	58	94	108	8,4	8,4
75	66	72	50	14	99	108	50	116	135	8,4	10,5
90	84	95	60	18	118	132	65	138	160	10,5	13
120	113	125	80	22	158	170	90	180	205	13	13

Designations	Designations slotted	Mass kg	Grease fitting	Screw ISO 4762 (only LHCS)
-			-	
LHCR 8 ^{§)}	LHCS 8 ^{§)}	0,018	-	M3
LHCR 12 ^{§)}	LHCS 12 ^{§)}	0,038	VN-LHC 20	M3
LHCR 16 ^{§)}	LHCS 16 ^{§)}	0,05	VN-LHC 20	M3
LHCR 20 ^{§)}	LHCS 20 ^{§)}	0,1	VN-LHC 20	M4
LHCR 25 ^{§)}	LHCS 25 ^{§)}	0,2	VN-LHC 40	M5
LHCR 30 ^{§)}	LHCS 30 ^{§)}	0,28	VN-LHC 40	M6
LHCR 40 ^{§)}	LHCS 40 ^{§)}	0,47	VN-LHC 40	M6
LHCR 50 ^{§)}	LHCS 50 ^{§)}	0,76	VN-LHC 50	M8
LHCR 60 ^{§)}	LHCS 60 ^{§)}	1,35	VN-LHC 80	M10
LHCR 80 ^{§)}	LHCS 80 ^{§)}	3,25	VN-LHC 80	M12

¹⁾ For housings from size 50 to 80: Tolerance $L/2 \pm 0,02$

²⁾ For cylinder head screws with internal hexagon according to ISO 4762

^{§)} Delivery time usually 10 days for max. quantity of 4; larger quantities on request

3.5.2 Standard housings - LHCT

- LHCT in open design

- Open design in sizes from 12 mm to 80 mm
- Lightweight die-cast aluminium housing
- Able to bolt from top or bottom side
- With reference side for linear alignment
- Supplied with grease fitting for lubrication and axial bearing fixation
- Possibility of adjustable clearance with Ewellix bearings



Please find suitable shaft blocks or shaft supports in **chapter 3.6** and shafts in **chapter 3.7**

Pictured is LHCT 30

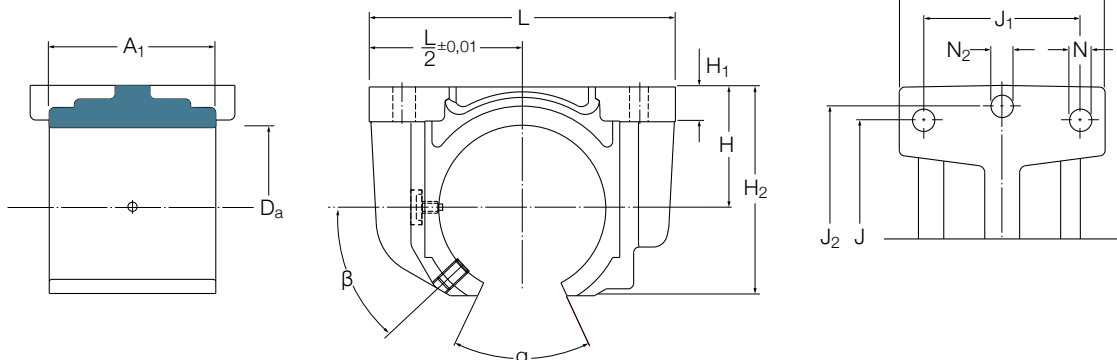

Dimensions													
D_a Tolerance J6 mm	A	A_1	H $\pm 0,01$	H_1	H_2	J	J_1	J_2	$L^{1)}$	$N^{2)}$	$N_2^{2)}$	α	β
													Deg.
22	31	20	18	6	28	32	23	42	52	4,3	5,3	78	29
26	34,5	22	22	7	35	40	26	46	56	4,3	5,3	78	27,6
32	41	28	25	8	42	45	32	58	70	4,3	6,4	60	42
40	52	40	30	10	51	60	40	68	80	5,3	6,4	60	43
47	59	48	35	10	60	68	45	76	88	6,4	6,4	50	43,6
62	74	56	45	12	77	86	58	94	108	8,4	8,4	50	42,5
75	66	72	50	14	88	108	50	116	135	8,4	10,5	50	30
90	84	95	60	18	105	132	65	138	160	10,5	13,0	54	30
120	113	125	80	22	140	170	90	180	205	13,0	13,0	54	30

Designations	Mass kg	Grease fitting	Grub screw ISO 4026
-		-	
LHCT 12 D ^{s)3)}	0,034	VN-LHC 20	M3
LHCT 16 D ^{s)3)}	0,045	VN-LHC 20	M3
LHCT 20 D ^{s)3)}	0,092	VN-LHC 20	M5
LHCT 25 D ^{u)3)}	0,18	VN-LHC 40	M5
LHCT 30 D ^{s)3)}	0,25	VN-LHC 40	M5
LHCT 40 D ^{u)3)}	0,41	VN-LHC 40	M5
LHCT 50 ^{s)}	0,67	VN-LHC 50	M6
LHCT 60 ^{s)}	1,18	VN-LHC 80	M8
LHCT 80 ^{s)}	2,86	VN-LHC 80	M8

¹⁾ For housings from size 50 to 80: Tolerance $L/2 \pm 0,02$
²⁾ For cylinder head screws with internal hexagon according to ISO 4762
³⁾ Adjustable clearance only for D-type bearings (example LBCT 16 D-2LS)
⁴⁾ Delivery time usually 10 days for max. quantity of 4; larger quantities on request
^{u)} Under development, A-series linear ball bearings of that size are available

3.6 Shaft blocks and shaft supports

Shaft blocks and supports are standard components to easily build up linear slides. Single shaft blocks are supposed to be used for closed design linear units with flexible shaft distance and length. In standard applications they fix the end of the shaft to the surface. Tandem blocks

are made specifically for Ewellix Quadro units to allow easy installation. Shaft supports are used for open design linear units and typically support the entire length of the shaft to avoid bending. They are all made out of aluminium based material.

LSCS



LSCS are lightweight die-cast shaft blocks to be used for compact or standard range units. These blocks securely fasten the shaft position. They can be bolted from top or bottom side and do have a reference side for linear alignment. LSCS shaft blocks are available for shaft diameters from 8 mm to 80 mm.

LSHS/LSNS



LSHS and LSNS shaft blocks are made of aluminium and securely fasten the shaft position. LSHS blocks are designed to be used with Ewellix compact range units, while LSNS blocks are made to fit to the design of the standard range units. They can be bolted from both sides to the mounting surface and are available from 12 mm to 50 mm.

LEBS/LEAS



LEBS tandem aluminium shaft blocks are made to match with duo or quadro units of the compact range, like LTDR and LQBR. The “A” design is made for moving slides where the tandem blocks are fixed to the surface. They are available from size 12 mm to 50 mm.

LEAS tandem aluminium shaft blocks are designed to match with quadro units of the standard range, like LQCR and LQCD. They are available in both “A” and “B” design, from shaft diameter 8 mm to 50 mm. Compared to the “A” design where the slide is moving and the shafts are fixed, the “B” design allows shaft movement while the quadro unit is fixed.

LRCB/LRCC



Shaft supports type LRCB/LRCC are suitable for standard range open design units where with heavy loads the shaft support avoids bending. Aluminium shaft supports can be used partially, but Ewellix recommends using them over the entire shaft length.

The LRCB design has predrilled hole patterns for mounting and direct bolting to Ewellix standard shafts ESSC 6, please see chapter 3.7, while LRCC has ready machined tolerances prepared for customized mounting holes. Ewellix shaft supports are offered from size 12 mm to 80 mm.

3.6.1 Shaft blocks - LSCS

- LSCS for compact or standard range

- Sizes from 8 mm to 80 mm
- Lightweight die-cast aluminium shaft block
- Shaft clamping screw direction from the top
- Able to bolt from top or bottom side to the surface
- Two different hole patterns for fixation
- Reference surface for linear alignment
- Precise and safe shaft fixation to the surface



Pictured is LSCS 20

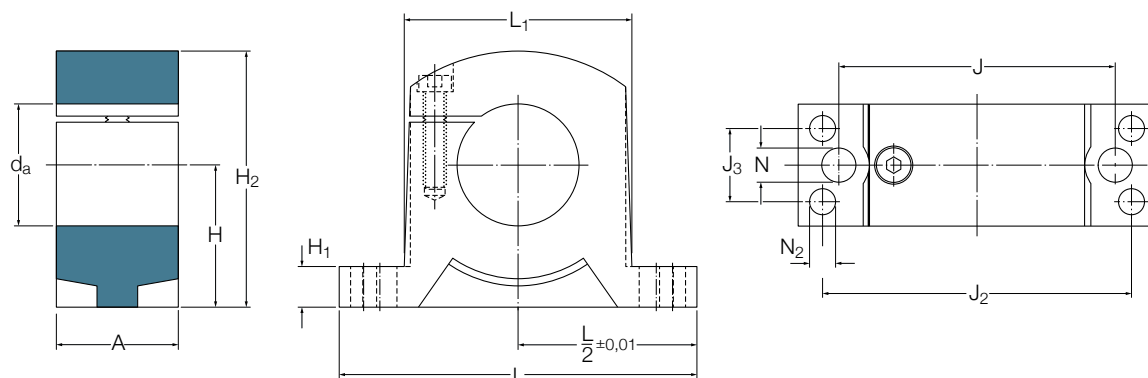

Dimensions												Designations	Mass	
d_a	A	H $\pm 0,01$	H_1	H_2	J	J_2	J_3	$L^{1)}$	L_1	$N^{2)}$	$N_2^{2)}$	Shaft block	kg	
mm													-	
8	10	15	5,5	25	25	35	5	45	19	4,3	2,7	LSCS 8	0,012	
12	12	20	6	32,5	32	42	6	52	25	5,3	3,2	LSCS 12	0,023	
16	15	20	7	35,5	40	46	7,5	56	31,8	5,3	4,3	LSCS 16	0,034	
20	20	25	8	43,5	45	58	10	70	37	5,3	5,3	LSCS 20	0,065	
25	28	30	10	53	60	68	16	80	48	6,4	6,4	LSCS 25	0,14	
30	30	35	10	63	68	76	18	88	56	8,4	6,4	LSCS 30	0,20	
40	36	45	12	81	86	94	22	108	71	10,5	8,4	LSCS 40	0,47	
50	49	50	14	92,5	108	116	30	135	86	10,5	10,5	LSCS 50	0,68	
60	62	60	18	112	132	138	40	160	105	13	13	LSCS 60	1,29	
80	85	80	22	147,5	170	180	60	205	136	17	15	LSCS 80	3,01	

Items are usually available from stock.

¹⁾ For shaft blocks from size 50 to 80: Tolerance $L/2 \pm 0,02$

²⁾ For cylinder head screws with internal hexagon according to ISO 4762

3.6.2 Compact shaft blocks - LSHS

- Sizes from 12 mm to 50 mm
- Shaft clamping screw direction from the side
- Able to bolt from top or bottom side to the surface
- Reference surface for linear alignment
- Precise and safe shaft fixation to the surface
- Material aluminium



Pictured is LSHS 20

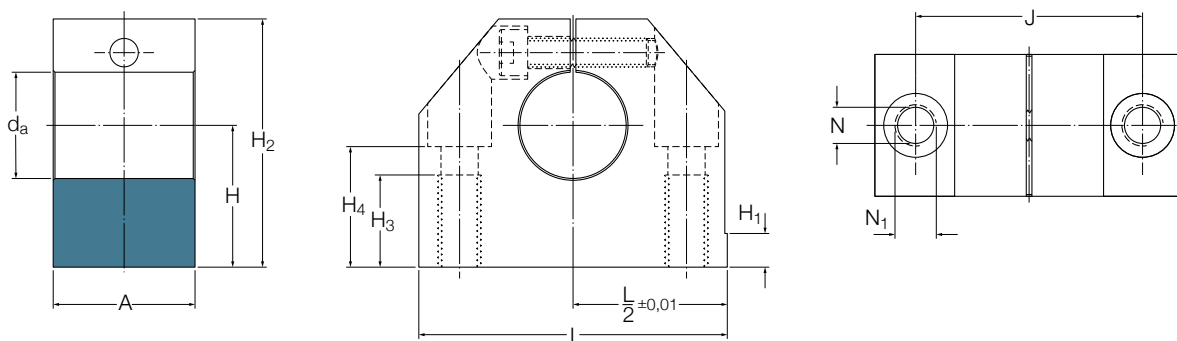

Dimensions											Designations	Mass	ISO series
d_a	A	H $\pm 0,01$	H_1	H_2	H_3	H_4	J	L	$N^{1)}$	N_1	Shaft block	kg	-
mm													
12	18	19	-	33	13	16,5	27	40	5,3	M6	LSHS 12	0,05	1
16	20	22	-	38	13	18	32	45	5,3	M6	LSHS 16	0,07	1
20	24	25	-	45	18	21	39	53	6,6	M8	LSHS 20	0,11	1
25	28	31	-	54	22	25	44	62	8,4	M10	LSHS 25	0,17	1
30	30	34	-	60	22	29	49	67	8,4	M10	LSHS 30	0,22	1
40	40	42	-	76	26	37	66	87	10,5	M12	LSHS 40	0,47	1
50	50	50	-	92	34	44	80	103	13,5	M16	LSHS 50	0,82	1

Items are usually available from stock.

¹⁾For cylinder head screws with internal hexagon according to ISO 4762



3.6.3 Standard shaft blocks - LSNS

- Sizes from 12 mm to 50 mm
- Shaft clamping screw direction from the side
- Able to bolt from top or bottom side to the surface
- Reference surface for linear alignment
- Precise and safe shaft fixation to the surface
- Material aluminium



Pictured is LSNS 20

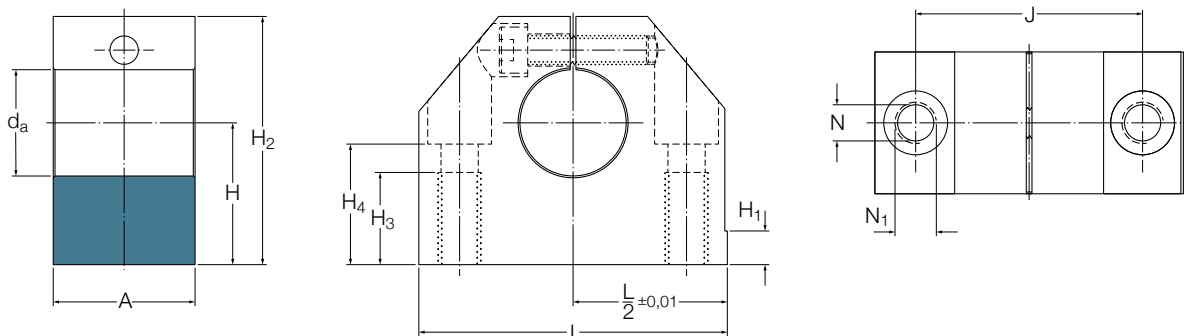

Dimensions											Designations	Mass	ISO series
d_a	A	H $\pm 0,01$	H_1	H_2	H_3	H_4	J	$L^{2)}$	$N^{1)}$	N_1	Shaft block	kg	-
mm													
12	20	20	6	35	13	16,5	30	43	5,3	M6	LSNS 12	0,06	3
16	24	25	7	42	18	21	38	53	6,6	M8	LSNS 16	0,11	3
20	30	30	7,5	50	22	25	42	60	8,4	M10	LSNS 20	0,17	3
25	38	35	8,5	61	26	30	56	78	10,5	M12	LSNS 25	0,34	3
30	40	40	9,5	70	26	34	64	87	10,5	M12	LSNS 30	0,46	3
40	48	50	11	90	34	44	82	108	13,5	M16	LSNS 40	0,90	3
50	58	60	11	105	43	49	100	132	17,5	M20	LSNS 50	1,45	3

Items are usually available from stock.

¹⁾ For cylinder head screws with internal hexagon according to ISO 4762

²⁾ Tolerance $L/2 \pm 0,01$

3.6.4 Compact tandem shaft blocks - LEBS

- Designed for compact duo LTDR or quadro units LQBR
- Supports easy building up of linear slides
- Sizes from 12 mm to 50 mm
- Shaft clamping and bolt direction from the top
- Precise and safe shaft fixation to the surface
- Material aluminium



Pictured is LEBS 30 A

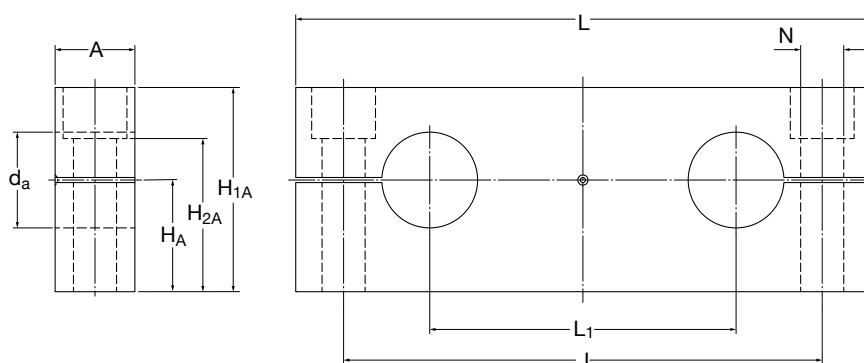

Dimensions									Designations	Mass	ISO series
d_a	A	H_A	H_{1A}	H_{2A}	J	L	L_1	N ¹⁾	Tandem shaft block Design A	Design A	
mm			$\pm 0,015$						–	kg	–
12	15	"	30	21,5	64	80	40	6,6	LEBS 12 A ^{s)}	0,08	1
16	15	19,5	35	26,5	80	96	52	6,6	LEBS 16 A ^{s)}	0,11	1
20	18	22	40	29	97	115	63	9	LEBS 20 A ^{s)}	0,17	1
25	20	27	50	36,5	115	136	75	11	LEBS 25 A ^{s)}	0,28	1
30	20	31	56	42,5	125	146	80	11	LEBS 30 A ^{s)}	0,32	1
40	25	38	70	54	160	184	97	13,5	LEBS 40 A ^{s)}	0,63	1
50	30	43	80	59	180	210	107	17,5	LEBS 50 A ^{s)}	0,79	1

^{s)} Delivery time usually 10 days for max. quantity of 4; larger quantities on request

¹⁾ For cylinder head screws with internal hexagon according to ISO 4762

3.6.5 Standard tandem shaft blocks- LEAS

- Designed for standard quadro units LQCR or LQCD
- Supports easy building up of linear slides
- Sizes from size 8 mm to 50 mm in aluminium material
- Shaft clamping and bolt direction from the top
- Precise and safe shaft fixation to the surface
- LEAS A variant for moving quadro slide and fixed shaft blocks to surface
- LEAS B variant for moving shaft blocks and fixed quadro unit



Pictured is LEAS 30

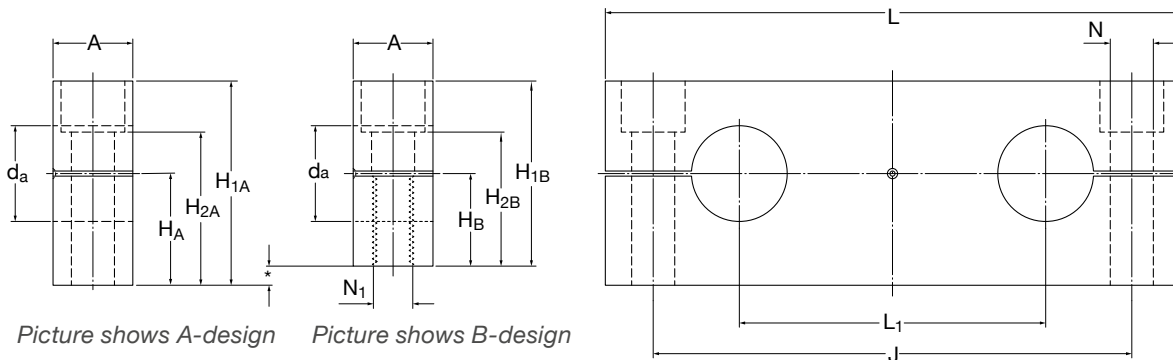

Dimensions												
d_a	A	H_A $\pm 0,015$	H_{1A}	H_{2A}	H_B $\pm 0,015$	H_{1B}	H_{2B}	J	L	L_1	$N^{1)}$	N_1
mm												-
8	12	12,5	23	16	11	22	15	52	65	32	5,5	M5
12	14	18	32	23,5	14	28	19,5	70	85	42	6,6	M6
16	18	20	37	26,5	17	34	23,5	82	100	54	9	M8
20	20	25	46	32,5	21	42	28,5	108	130	72	11	M10
25	25	30	56	40	26	52	36	132	160	88	13,5	M12
30	25	35	64	48	29	58	42	150	180	96	13,5	M12
40	30	44	80	59	36	72	51	190	230	122	17,5	M16
50	30	52	96	75	44	88	67	240	280	152	17,5	M16

Designations		Mass		ISO series
Tandem shaft block		Design		-
Design		A	B	
A	B	kg		
-				
LEAS 8 A ^{s)}	LEAS 8 B ^{s)}	0,04	0,04	3
LEAS 12 A ^{s)}	LEAS 12 B ^{s)}	0,09	0,07	3
LEAS 16 A ^{s)}	LEAS 16 B ^{s)}	0,14	0,13	3
LEAS 20 A ^{s)}	LEAS 20 B ^{s)}	0,25	0,22	3
LEAS 25 A ^{s)}	LEAS 25 B ^{s)}	0,47	0,44	3
LEAS 30 A ^{s)}	LEAS 30 B ^{s)}	0,62	0,56	3
LEAS 40 A ^{s)}	LEAS 40 B ^{s)}	1,15	1,00	3
LEAS 50 A ^{s)}	LEAS 50 B ^{s)}	1,70	1,52	3

^{s)} Delivery time usually 10 days for max. quantity of 4; larger quantities on request

¹⁾ For cylinder head screws with internal hexagon according to ISO 4762

3.6.6 Standard shaft supports - LRCB/LRCC

- LRCB with mounting holes
- LRCC without mounting holes

- Designed for all open type linear bearings and units
- Sizes from size 12 mm to 50 mm in aluminium material
- For complete or partial shaft support
- Able to bolt from top or bottom side to the surface
- LRCB with Ewellix standard shaft hole pattern ESSC6 (↳ chapter 3.7)
- LRCC machined for customized hole patterns



Pictured is LRCB

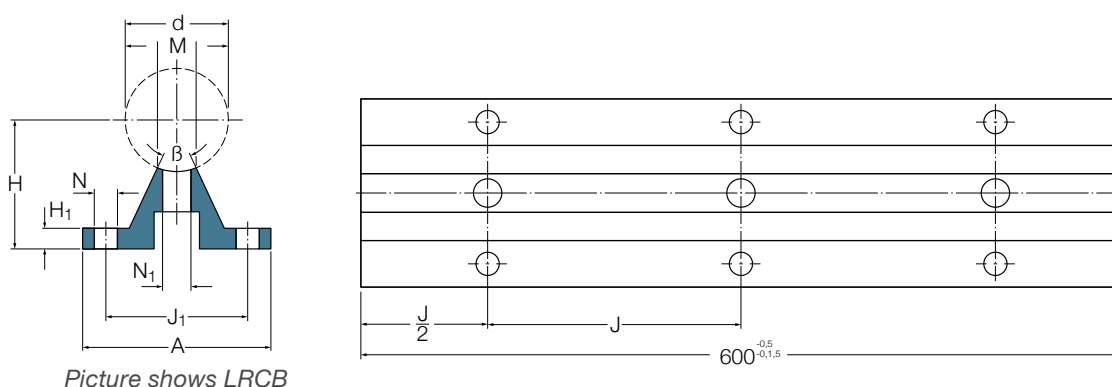

Picture shows LRCC

Dimensions										
d	A	H ±0,02	H ₁	J	J ₁	M	N ¹⁾	N ₁ ¹⁾	β	
mm										Deg.
12	40	22	5	75	29	5,8	4,5	4,5	50	
16	45	26	5	100	33	7	5,5	5,5	50	
20	52	32	6	100	37	8,3	6,6	6,6	50	
25	57	36	6	120	42	10,8	6,6	9	50	
30	69	42	7	150	51	11	9	11	50	
40	73	50	8	200	55	15	9	11	50	
50	84	60	9	200	63	19	11	13,5	46	
60	94	68	10	300	72	25	11	15,5	46	
80	116	86	12	300	92	34	13,5	17,5	46	

Designations		Mass	Shaft attachment screw ¹⁾
with mounting holes	without mounting holes	LRCB	
-		kg	-
LRCB 12	LRCC 12 ^{§)}	0,53	M4x16
LRCB 16	LRCC 16 ^{§)}	0,64	M5x20
LRCB 20	LRCC 20 ^{§)}	0,92	M6x25
LRCB 25	LRCC 25 ^{§)}	1,08	M8x25
LRCB 30	LRCC 30 ^{§)}	1,41	M10x30
LRCB 40	LRCC 40 ^{§)}	1,85	M10x35
LRCB 50	LRCC 50 ^{§)}	2,45	M12x40
LRCB 60	LRCC 60 ^{§)}	3,25	M14x45
LRCB 80	LRCC 80 ^{§)}	4,40	M16x55

Items without letter footnote are usually available from stock.

^{§)} Delivery time usually 10 days for max. quantity of 4; larger quantities on request

¹⁾ LRCB has holes for cylinder head screws with internal hexagon according to ISO 4762

3.7 Precision shafts

Ewellix precision shafts can be supplied either as solid or hollow shafts. Solid shafts are available in all dimensions required to fit Ewellix linear ball bearings. Hollow shafts have a minimum outer diameter of 12 mm. They are induction hardened and ground. Ewellix shafts have exceptionally high dimensional stability and are designed for long service life.

For special applications, solid shafts of stainless steel or hard chromium plated shafts with a layer thickness from 10 - 15 µm can be supplied.

Surface finish

All Ewellix precision steel shafts have a maximum surface roughness of $R_a = 0,3 \mu\text{m}$.

Materials

The shaft material differs with the shaft type, as indicated in table below.

Shaft type		Material	Hardness
			HRC
Solid shaft			
LJM	high-grade steel	1.1213 (Cf53) ¹⁾	60 - 64
LJMR	stainless steel	1.4112 (X90CrMoV18) ¹⁾	52 - 56
LJMS	stainless steel	1.4034 (X46Cr13) ¹⁾	52 - 56
Solid shaft, hard chromium plated			
LJMH	high-grade steel	1.1213 (Cf53) ¹⁾	60 - 64
Hollow shaft			
LJT	high-grade steel	1.3505 (100Cr6) ¹⁾	60 - 64

¹⁾ or equal

The table with hardness depths shows minimum values. In reality the hardness depth may also be greater than indicated in the table and this may have an influence on the machinability of the shafts. The ends of uncut shafts in production length may deviate in hardness and dimensional accuracy.



Tolerances

All Ewellix precision shafts without coating are supplied in tolerance h6 as standard. Hard chromium plated shafts LJM_H are supplied in tolerance h7. The accuracy of dimensions and form of these shafts can be found on page 97. There may be slight deviations from the values provided in the tables for sections of the shaft that have been annealed. Shafts cut to length have a length tolerance according to the adjacent table.

Shafts with radial holes

Radial holes are needed if a shaft has to be mounted onto a shaft support. The radial holes may be either positioned to fit Ewellix shaft supports (suffix ESSC 6) or as specified by the customer (suffix ESSC 7). The values for thread size and depth provided in the adjacent table must be adhered to when customising shafts. Ewellix shafts with radial holes are not annealed at the drilling position. The thread is cut in the hardened and ground shaft to avoid any changes in hardness or dimensional accuracy.

Jointed shafts

Ewellix can supply jointed shafts on request. Screwed joints are recommended for unsupported shafts. Plug and socket joints are used with supported shafts. Ewellix takes care for accurately machined joints, e.g. regarding concentricity, as they are vital for smooth transitions at the joints.

A customer drawing with details and defined joint positions is necessary to handle a request or order.

NOTE for customised solutions:

The length of the shaft and the position of the supports should be determined so that any bending of the shaft does not cause a gap at the joint. When drilling radial holes for the supports, drill as close as possible to the joint.

Corrosion protection, packaging

Ewellix precision shafts are treated with a rust inhibiting preservative that must be removed before the shafts are installed. Depending on size and quantity, precision shafts are supplied in cardboard or wooden boxes that offer maximum protection during transport.

Please contact us for special freight or storage conditions, e.g. overseas.

Hardness depths of shafts

Shaft diameter > mm	≤	Hardness depth min.
3	10	0,4
10	18	0,6
18	30	0,9
30	50	1,5
50	80	2,2

Length tolerances for shafts

Nominal length > mm	≤	Deviation
10	2 000	± 1,5
2 000	4 000	± 2
4 000	8 000	± 3

Maximum length of precision shafts

Shaft diameter mm	Maximum length ¹⁾				
	LJM	LJMR	LJMS	LJM _H	LJT
3 ²⁾	1 000	300	-	-	-
4 ²⁾	3 000	3 000	-	-	-
5	3 000	3 000	-	3 000	-
6	3 000	3 000	3 000	3 000	-
8	3 000	3 000	3 000	3 000	-
10	3 000	3 000	3 000	3 000	-
12	6 000	6 000	6 000	6 000	6 000
14	6 000	6 000	6 000	6 000	-
16	6 000	6 000	6 000	6 000	6 000
20	6 000	6 000	6 000	6 000	6 000
25	6 000	6 000	6 000	6 000	6 000
30	6 000	6 000	6 000	6 000	6 000
40	6 000	6 000	6 000	6 000	6 000
50	6 000	6 000	6 000	6 000	6 000
60	6 000	6 000	6 000	6 000	6 000
80	6 000			6 000	6 000

¹⁾ Length tolerance ±10 % (based on maximum shaft length). Maximum length < production length. Both ends are cut, this means no deviation of hardness or dimensional accuracy.

²⁾ Only available as ESSC 2, see **next page**

Shafting standard – ESSC

Ewellix offers different standards to specify how both ends of the shaft should look. The choice has to be mentioned in the ordering key. For example, the designation for a shaft with 20 mm diameter cut to a length of 1,5 m and with chamfers is LJM 20x1 500 ESSC2. The standard ESSC 10 is for shafts machined according to the customer drawing.

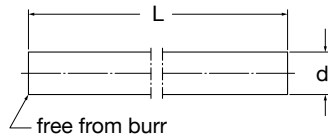

ESSC 1

cut with deburring

- length tolerance \hookrightarrow page 89

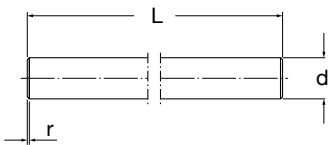

ESSC 2

cut with chamfer

- length tolerance \hookrightarrow page 89
- chamfer with value r to be at least 1 mm

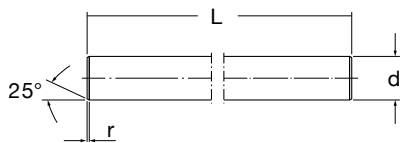

ESSC 3

front surface machined to 90° and chamfer with 25°

- length tolerance \pm 0,1 mm up to 3 000 mm total length
- defined chamfer with minimum value r as defined on page 92

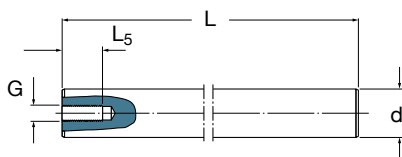

ESSC 4

as ESSC 3
+ one axial hole

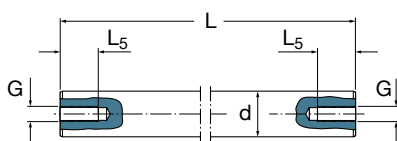

ESSC 5

as ESSC 3
+ two axial holes

Dimensions of front side threads for ESSC 4, 5

d mm	G -	L5 mm
5	-	-
8	M4	10
10	M4	10
12	M5	12,5
14	M5	12,5
16	M6	15
20	M8	20
25	M10	25
30	M10	25
40	M12	30
50	M16	40
60	M20	50
80	M24	60

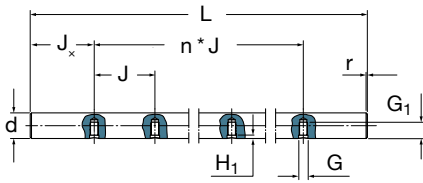
**ESSC 6**

as ESSC 2

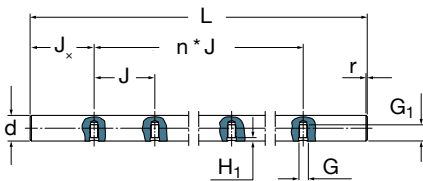
+ radial holes for shaft support LRCB (↳ [chapter 3.6.6](#))+ first radial hole at $J_x = J/2$ + H_1 according to hardness depth**ESSC 7**

as ESSC 2

+ radial holes

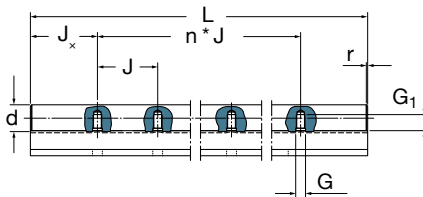
+ dimension J_x and J according to customer specification+ H_1 according to hardness depth**ESSC 8**

as ESSC 6

+ shaft mounted on shaft support with mounting holes LRCB

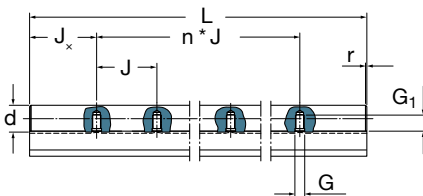
(↳ [chapter 3.6.6](#))**ESSC 9**

as ESSC 6

+ shaft mounted on shaft support without mounting holes LRCC

(↳ [chapter 3.6.6](#))**Dimensions of radial threads for ESSC 6, 7, 8, 9**

d mm	Thread -	G mm	G ₁	J	J _x
12	M4	5	8	75	37,5
16	M5	6	9,5	100	50
20	M6	7	13	100	50
25	M8	9	14	120	60
30	M10	11	18	150	75
40	M10	11	20	200	100
50	M12	13	23	200	100
60	M14	15	28	300	150
80	M16	16	33	300	150

Precision shafts

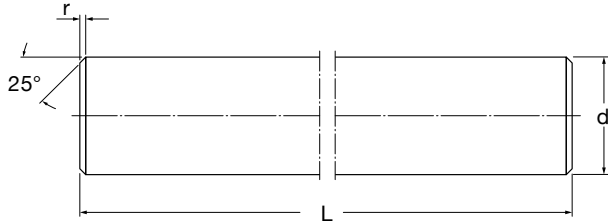

Picture shows solid shaft with shafting standard ESSC 3

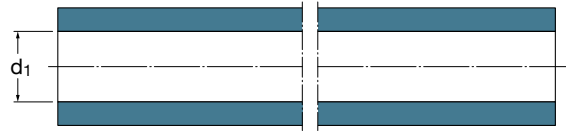

Picture shows hollow shaft with shafting standard ESSC 1

Dimensions			Mass		Moment of inertia		Cross sectional area		Designation ¹⁾					
d	d ₁	r ³⁾	Solid shaft	Hollow shaft	Solid shaft	Hollow shaft	Solid shaft	Hollow shaft	Solid shaft			Hollow shaft		
									high-grade steel	stainless steel ²⁾	stainless steel ²⁾	high-grade steel and hard chromium plated	high-grade steel	
mm			kg/m		cm ⁴		mm ²		1.1213 or equal	1.4112 or equal	1.4034 or equal	1.1213 or equal	1.3505 or equal	
3	—	0,4	0,06	—	0,0004	—	7,1	—	LJM 3	LJMR 3				
4	—	0,4	0,1	—	0,0013	—	12,6	—	LJM 4	LJMR 4				
5	—	0,8	0,15	—	0,0031	—	19,6	—	LJM 5	LJMR 5		LJMH 5		
6	—	0,8	0,22	—	0,0064	—	28,3	—	LJM 6	LJMR 6	LJMS 6	LJMH 6		
8	—	0,8	0,39	—	0,02	—	50,3	—	LJM 8	LJMR 8	LJMS 8	LJMH 8		
10	—	0,8	0,62	—	0,049	—	78,5	—	LJM 10	LJMR 10	LJMS 10	LJMH 10		
12	4	1	0,89	0,79	0,102	0,1	113	101	LJM 12	LJMR 12	LJMS 12	LJMH 12	LJT 12	
14	—	1	1,21	—	0,189	—	154	—	LJM 14	LJMR 14	LJMS 14	LJMH 14		
16	7	1	1,58	1,28	0,322	0,31	201	163	LJM 16	LJMR 16	LJMS 16	LJMH 16	LJT 16	
20	14	1,5	2,47	1,25	0,785	0,597	314	160	LJM 20	LJMR 20	LJMS 20	LJMH 20	LJT 20	
25	16 ⁴⁾	1,5	3,86	2,35	1,92	1,64	491	305	LJM 25	LJMR 25	LJMS 25	LJMH 25	LJT 25	
30	18	1,5	5,55	3,5	3,98	3,46	707	453	LJM 30	LJMR 30	LJMS 30	LJMH 30	LJT 30	
40	28 ⁴⁾	2	9,86	4,99	12,6	9,96	1 260	685	LJM 40	LJMR 40	LJMS 40	LJMH 40	LJT 40	
50	30	2	15,4	9,91	30,7	27,7	1 960	1 350	LJM 50	LJMR 50	LJMS 50	LJMH 50	LJT 50	
60	36	2,5	22,2	14,2	63,6	57,1	2 830	1 920	LJM 60	LJMR 60	LJMS 60	LJMH 60	LJT 60	
80	57	2,5	39,5	19,43	201	153	5 030	2 565	LJM 80			LJMH 80	LJT 80	

¹⁾ Delivery time of shafts on request

²⁾ Basic load ratings are valid for bearing steel and stainless steel variants. They must be reduced with stainless steel shafts only

³⁾ The values r given in that table represent the minimum values of r.

⁴⁾ d₁ can deviate from the given value. Please enquire if necessary

Precision shafts of high-grade steel

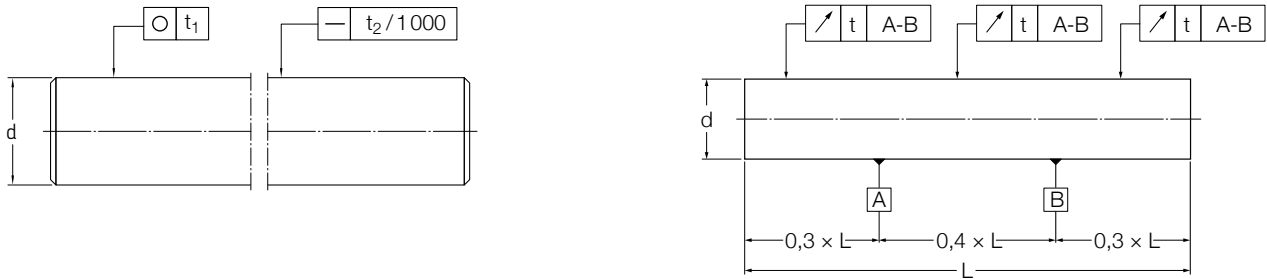

Measuring principle of straightness

Shaft Nominal diameter d mm	Accuracy of dimension and form Shafts in tolerance h6 ¹⁾					Shafts in tolerance h7				
	Diameter deviation high low μm		Roundness t ₁	Cylindricity t ₂	Straightness t ₃	Diameter deviation high low		Roundness t ₁	Cylindricity t ₂	Straightness t ₃
3	0	-6	3	4	150	0	-10	4	6	150
4	0	-8	4	5	150	0	-12	5	8	150
5	0	-8	4	5	150	0	-12	5	8	150
6	0	-8	4	5	150	0	-12	5	8	150
8	0	-9	4	6	120	0	-15	6	9	120
10	0	-9	5	7	120	0	-15	7	10	120
12	0	-11	5	8	100	0	-18	8	11	100
14	0	-11	5	8	100	0	-18	8	11	100
16	0	-11	5	8	100	0	-18	8	11	100
20	0	-13	6	9	100	0	-21	9	13	100
25	0	-13	6	9	100	0	-21	9	13	100
30	0	-13	6	9	100	0	-21	9	13	100
40	0	-16	7	11	100	0	-25	11	16	100
50	0	-16	7	11	100	0	-25	11	16	100
60	0	-19	8	13	100	0	-30	13	19	100
80	0	-19	8	13	100	0	-30	13	19	100

¹⁾ All precision shafts without coating are supplied in tolerance h6 as standard. Higher precision on request. Hard chromium plated shafts LJM only in h7.

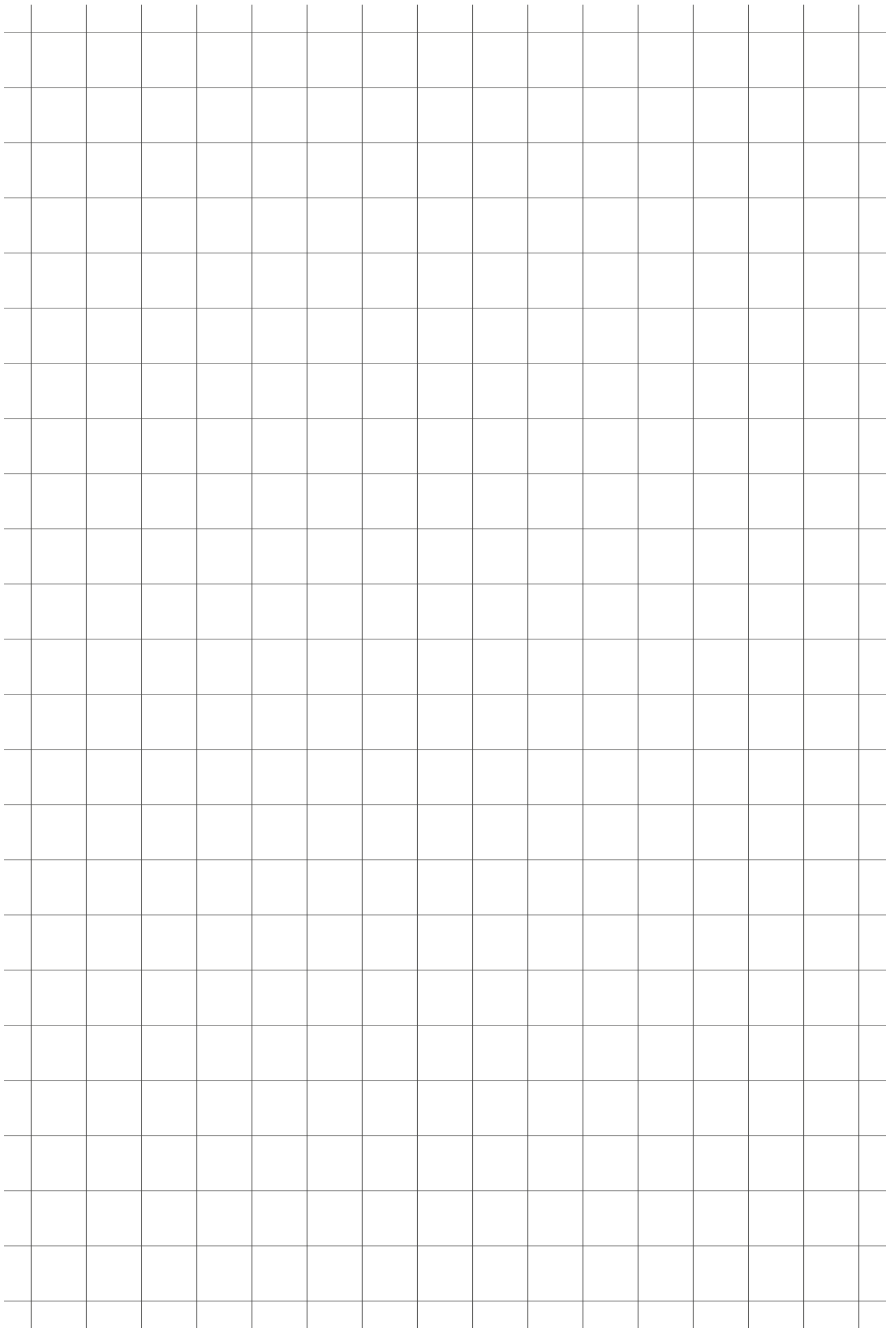

3.8 Linear slides

LZ slides are a complete linear bearing slides for manual motion ready to use in your application. All needed linear bearing components and shafts are already bundled in the LZ designation. Only the length of the slide system must be determined and the rest is predefined. LZ slides are easy customer friendly linear motion solutions. LZ slides are quadro unit based slides with shafts and shaft blocks or supports. The bearing unit is equipped with four LBCD or LBCF self-aligning linear ball bearings.

Three different variants exist to fit nearly every application. The LZBU-“A” variant enables axial movement of the quadro unit, whereby the shafts are fixed via the tandem shaft blocks to the machine surface. The LZBU-“B” variant is provided with LEAS-“B” shaft blocks. This combination is made for moving linear shafts and shaft blocks while the quadro unit is fixed to the machine. LZAU are the open type linear slides made for longer travel distances with shaft supports.

All slides can be supplied with stainless steel bearings and shafts. The slides are always equipped with linear bearings that have seals on the outside. LZAU linear slides can be supplied from size 12 mm to 50 mm, where LZBU slides are available from 8 mm to 50 mm. The bearing unit is factory pre-lubricated and ready for use. In case relubrication is needed, the units are equipped with two grease fittings from either side. Only size 8 must be relubricated via the shafts.

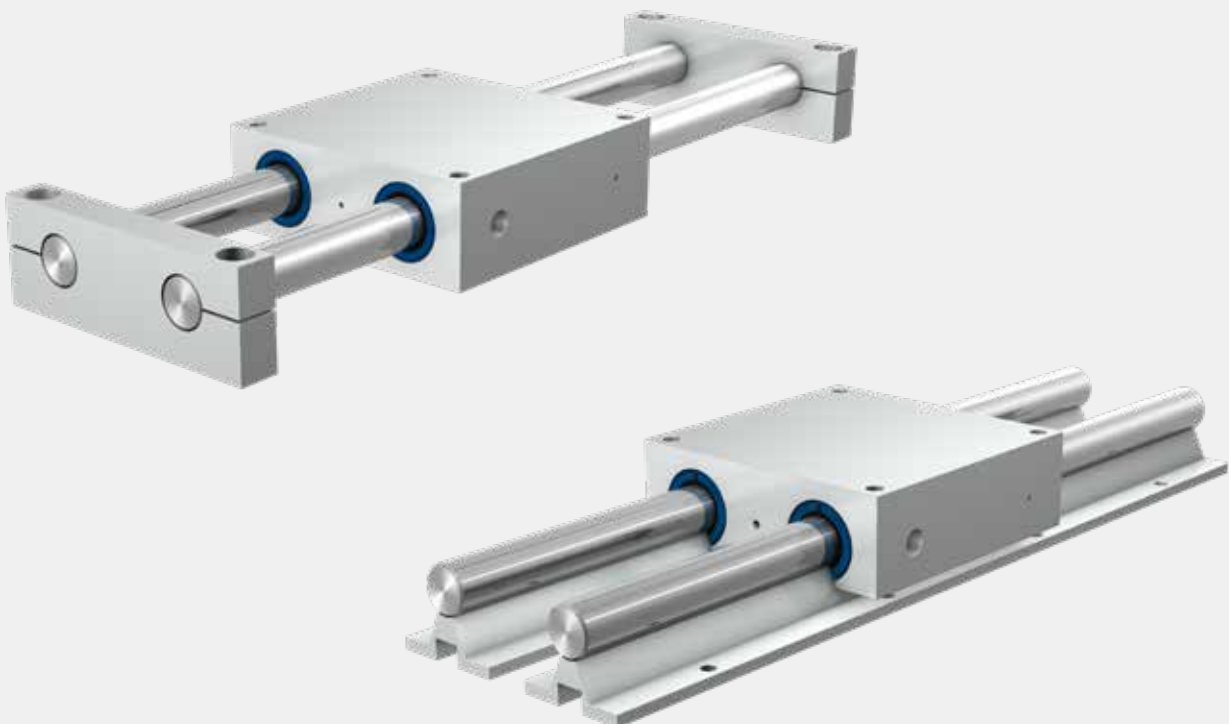

3.8.1 Linear slides - LZBU A

- Designed for fixed shaft blocks and moving quadro unit

- Sizes from 8 mm to 50 mm
- Equipped with 4 self-aligning LBCD bearings
- Sealed standard and stainless steel variant
- Factory pre-lubricated with SKF LGEP 2 grease, ready for use
- Equipped with grease fittings on both sides
- Quadro unit able to bolt from top or bottom side
- Standard slides consist of following parts:
 - One standard quadro unit LQCD -2LS
 - Two tandem shaft blocks LEAS-A
 - Two precision shafts LJM of the defined length
 - Stainless slides with LQCD -2LS/HV6 variant and LJMR precision shafts



Pictured is LZBU 30 A-2LS ²⁾

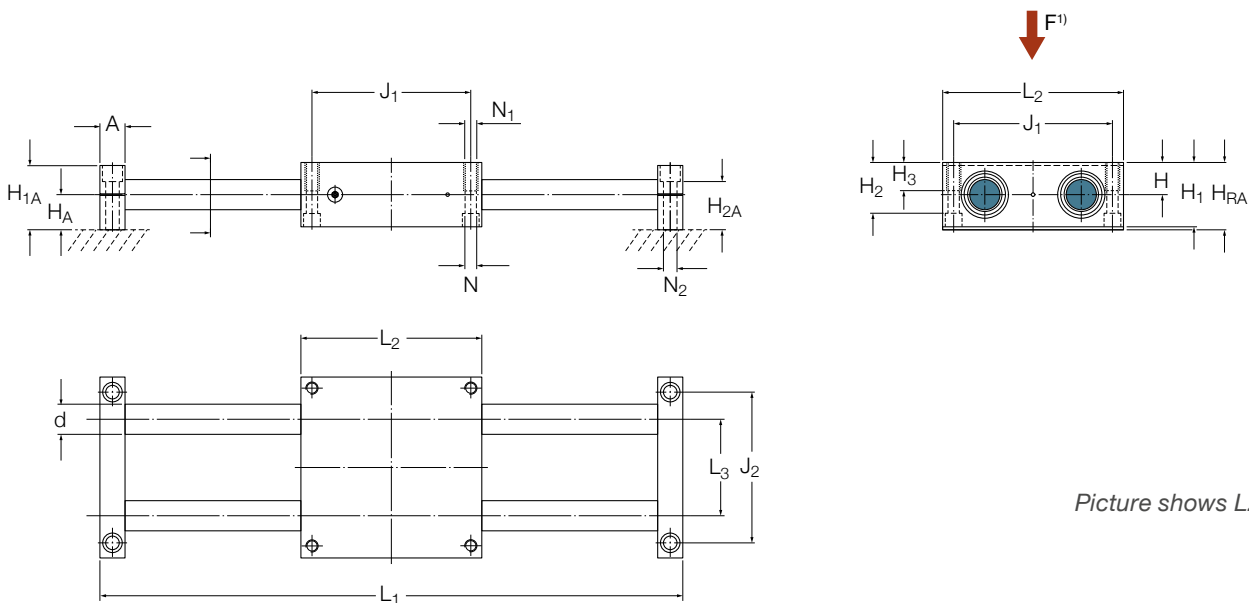

Picture shows LZBU...A

Dimensions

d	A	H _{RA} ±0,03	H _A ±0,015	H _{1A}	H _{2A}	H ±0,01	H ₁	H ₂	H ₃	J ₁	J ₂	L ₁ ³⁾	L ₂	L ₃	N ²⁾	N ₁	N ₂ ²⁾
mm																-	mm
8	12	24	12,5	23	16	11,5	23	17,5	11	55	52	600	65	32	4,3	M5	5,5
12	14	34	18	32	23,5	16	32	25	13	73	70	900	85	42	5,3	M6	6,6
16	18	38	20	37	26,5	18	36	29	13	88	82	1500	100	54	5,3	M6	9
20	20	48	25	46	32,5	23	46	37,5	18	115	108	1800	130	72	6,6	M8	11
25	25	58	30	56	40	28	56	45	22	140	132	1800	160	88	8,4	M10	13,5
30	25	67	35	64	48	32	64	50,5	26	158	150	2400	180	96	10,5	M12	13,5
40	30	84	44	80	59	40	80	64	34	202	190	3000	230	122	13,5	M16	17,5
50	30	100	52	96	75	48	96	80	34	250	240	3000	280	152	13,5	M16	17,5

¹⁾ Direction for max. load ratings

²⁾ Picture with non D-series bearing differs

³⁾ Recommended maximum shaft length. On demand, longer shaft lengths are available. Length tolerance according ESSEC2 shafting standard.

⁴⁾ For cylinder head screws with internal hexagon according to ISO 4762

LZBU... A

Designations ¹⁾	Basic load ratings			
	dynamic C		static C ₀	
–	min N	max	min	max
LZBU 8 A-2LS ^{2) n)}	1 290	1 500	1 430	2 000
LZBU 12 A-2LS ⁿ⁾	2 120	3 200	2 280	3 750
LZBU 16 A-2LS ⁿ⁾	2 500	3 650	2 600	4 250
LZBU 20 A-2LS ⁿ⁾	4 550	6 700	4 500	7 200
LZBU 25 A-2LS ⁿ⁾	6 800	10 000	5 700	9 300
LZBU 30 A-2LS ⁿ⁾	10 000	14 600	9 300	15 000
LZBU 40 A-2LS ⁿ⁾	17 300	25 500	13 400	22 800
LZBU 50 A-2LS ⁿ⁾	21 200	30 000	16 600	28 000

LZBU... A stainless

Designations ¹⁾	Basic load ratings ³⁾			
	dynamic C		static C ₀	
–	min N	max	min	max
LZBU 8 A-2LS/HV6 ^{2) n)}	1 080	1 250	1 320	1 830
LZBU 12 A-2LS/HV6 ⁿ⁾	1 760	2 650	2 080	3 450
LZBU 16 A-2LS/HV6 ⁿ⁾	2 080	3 050	2 400	3 900
LZBU 20 A-2LS/HV6 ⁿ⁾	3 800	5 600	4 150	6 550
LZBU 25 A-2LS/HV6 ⁿ⁾	5 600	8 300	5 200	8 500
LZBU 30 A-2LS/HV6 ⁿ⁾	8 300	12 200	8 500	13 700
LZBU 40 A-2LS/HV6 ⁿ⁾	14 300	21 200	12 200	20 800
LZBU 50 A-2LS/HV6 ⁿ⁾	17 600	25 000	15 300	26 000

ⁿ⁾ Delivery time on request

¹⁾ The designation for a LZBU linear slide with a shaft length of, for instance 1200 mm, is LZBU .. A-2LS x 1200. Delivered as a kit of parts

²⁾ Slides in size 8 mm cannot be relubricated and are equipped with rigid LBCR linear bearings

³⁾ Calculated with HRC 55 due to stainless shafts

3.8.2 Linear slides - LZBU B

- Designed for fixed quadro unit and moving shaft blocks

- Sizes from 8 mm to 50 mm
- Equipped with 4 self-aligning LBCD bearings
- Sealed standard and stainless steel variant
- Factory pre-lubricated with SKF LGEP 2 grease, ready for use
- Equipped with grease fittings on both sides
- Quadro unit able to bolt from top or bottom side
- Standard slides consist of following parts:
 - One standard quadro unit LQCD -2LS
 - Two tandem shaft blocks LEAS-B
 - Two precision shafts LJM of the defined length
 - Stainless slides with LQCD -2LS/HV6 variant and LJMR precision shafts



Pictured is LZBU 30 B-2LS ²⁾

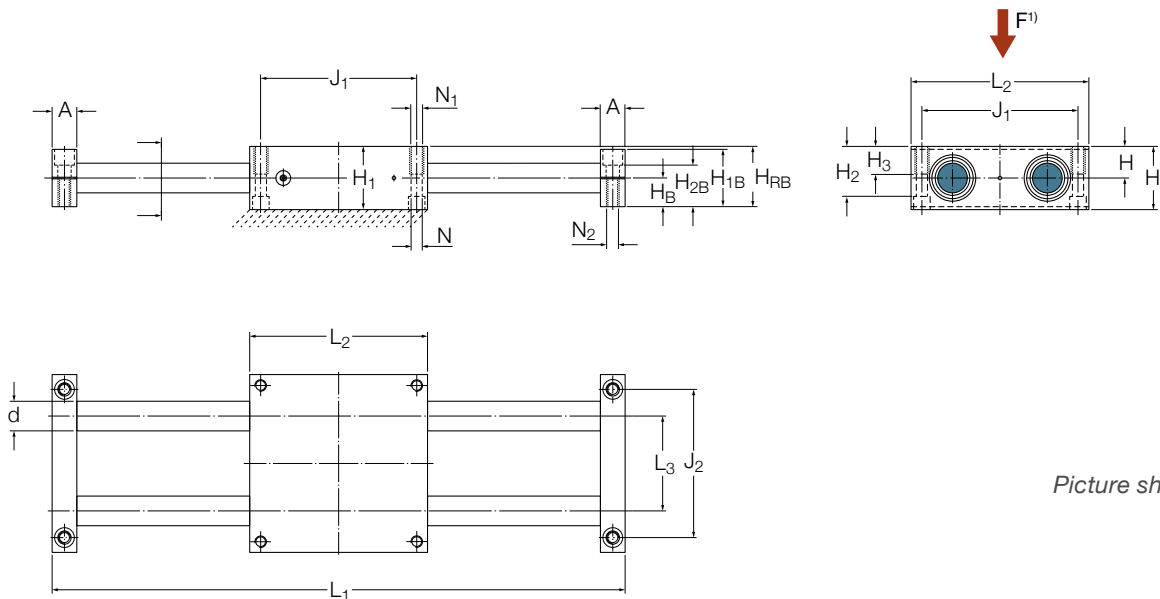

Picture shows LZBU...B

Dimensions

d	A	H _{RB} ±0,03	H _B ±0,015	H _{1B}	H _{2B}	H ±0,01	H ₁	H ₂	H ₃	J ₁	J ₂	L ₁ ³⁾	L ₂	L ₃	N ⁴⁾	N ₁	N ₂ ⁴⁾
8	12	22,5	11	22	15	11,5	23	17,5	11	55	52	600	65	32	4,3	M5	M5
12	14	30	14	28	19,5	16	32	25	13	73	70	900	85	42	5,3	M6	M6
16	18	35	17	34	23,5	18	36	29	13	88	82	1 500	100	54	5,3	M6	M6
20	20	44	21	42	28,5	23	46	37,5	18	115	108	1 800	130	72	6,6	M8	M8
25	25	54	26	52	36	28	56	45	22	140	132	1 800	160	88	8,4	M10	M10
30	25	61	29	58	42	32	64	50,5	26	158	150	2 400	180	96	10,5	M12	M12
40	30	76	36	72	51	40	80	64	34	202	190	3 000	230	122	13,5	M16	M16
50	30	92	44	88	67	48	96	80	34	250	240	3 000	280	152	13,5	M16	M16

¹⁾ Direction for max. load ratings

²⁾ Picture with non D-series bearing differs

³⁾ Recommended maximum shaft length. On demand, longer shaft lengths are available. Length tolerance according ESSE2 shafting standard.

⁴⁾ For cylinder head screws with internal hexagon according to ISO 4762

LZBU... B

Designations ¹⁾	Basic load ratings			
	dynamic C		static C ₀	
–	min N	max	min	max
LZBU 8 B-2LS ^{2) n)}	1 290	1 500	1 430	2 000
LZBU 12 B-2LS ⁿ⁾	2 120	3 200	2 280	3 750
LZBU 16 B-2LS ⁿ⁾	2 500	3 650	2 600	4 250
LZBU 20 B-2LS ⁿ⁾	4 550	6 700	4 500	7 200
LZBU 25 B-2LS ⁿ⁾	6 800	10 000	5 700	9 300
LZBU 30 B-2LS ⁿ⁾	10 000	14 600	9 300	15 000
LZBU 40 B-2LS ⁿ⁾	17 300	25 500	13 400	22 800
LZBU 50 B-2LS ⁿ⁾	21 200	30 000	16 600	28 000

LZBU... B stainless

Designations ¹⁾	Basic load ratings ³⁾			
	dynamic C		static C ₀	
–	min N	max	min	max
LZBU 8 B-2LS/HV6 ^{2) n)}	1 080	1 250	1 320	1 830
LZBU 12 B-2LS/HV6 ⁿ⁾	1 760	2 650	2 080	3 450
LZBU 16 B-2LS/HV6 ⁿ⁾	2 080	3 050	2 400	3 900
LZBU 20 B-2LS/HV6 ⁿ⁾	3 800	5 600	4 150	6 550
LZBU 25 B-2LS/HV6 ⁿ⁾	5 600	8 300	5 200	8 500
LZBU 30 B-2LS/HV6 ⁿ⁾	8 300	12 200	8 500	13 700
LZBU 40 B-2LS/HV6 ⁿ⁾	14 300	21 200	12 200	20 800
LZBU 50 B-2LS/HV6 ⁿ⁾	17 600	25 000	15 300	26 000

ⁿ⁾ Delivery time on request

¹⁾ The designation for a LZBU linear slide with a shaft length of, for instance 1200 mm, is LZBU .. B-2LS x 1200. Delivered as a kit of parts

²⁾ Slides in size 8 mm cannot be relubricated and are equipped with rigid LBCR linear bearings

³⁾ Calculated with HRC 55 due to stainless shafts

3.8.3 Linear slides - LZAU

- Open design from sizes 12 mm to 50 mm
- Equipped with 4 self-aligning LBCF bearings
- Sealed standard and stainless steel variant
- Factory pre-lubricated with SKF LGEP 2 grease, ready for use
- Equipped with grease fittings on both sides
- Quadro unit able to bolt from top or bottom side
- Standard slides consist of following parts:
 - One standard quadro unit LQCF -2LS
 - Two precision shafts LJM of the defined length supported by LRCB shaft supports
 - Stainless slides with LQCD -2LS/HV6 variant and LJMR precision shafts

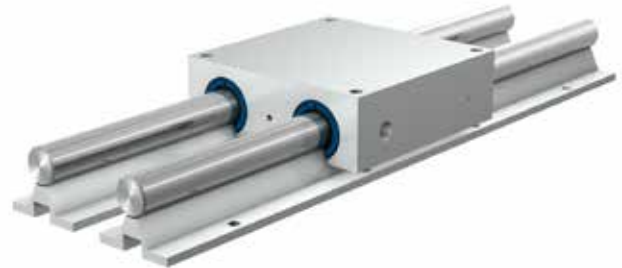

Pictured is LZAU 30-2LS ²⁾

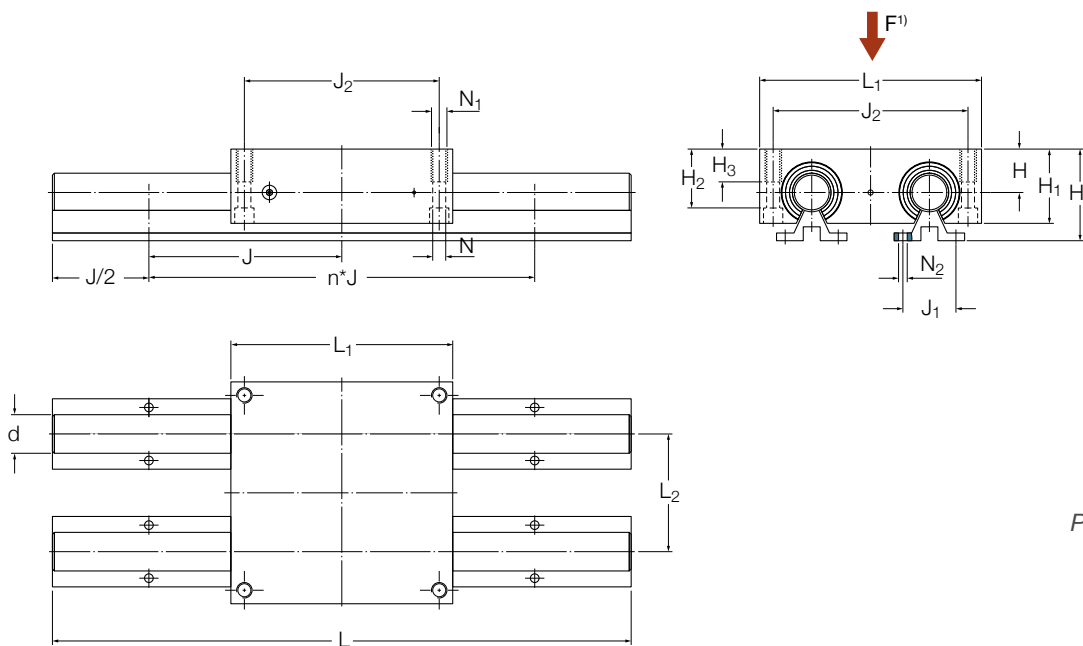

Picture shows LZAU

Dimensions

d	H _T ± 0,03	H ± 0,01	H ₁	H ₂	H ₃	J ³⁾	J ₁	J ₂	L ₁	L ₂	N ²⁾	N ₁	N ₂ ²⁾
mm												-	mm
12	40	18	30	23,4	13	75	29	73	85	42	5,3	M6	4,5
16	48	22	35	28,4	13	100	33	88	100	54	5,3	M6	5,5
20	57	25	42	33,5	18	100	37	115	130	72	6,6	M8	6,6
25	66	30	51	40	22	120	42	140	160	88	8,4	M10	6,6
30	77	35	60	46,5	26	150	51	158	180	96	10,5	M12	9
40	95	45	77	61	34	200	55	202	230	122	13,5	M16	9
50	115	55	93	77	34	200	63	250	280	152	13,5	M16	11

¹⁾ Direction for max. load ratings

²⁾ Picture with non D-series bearing differs

³⁾ Shaft with shafting standard ESSE 8 is used.

⁴⁾ For cylinder head screws with internal hexagon according to ISO 4762

LZAU

Designations ¹⁾	Basic load ratings			
	dynamic C		static C ₀	
–	min N	max	min	max
LZAU 12-2LS ⁿ⁾	1 600	2 850	1 660	3 400
LZAU 16-2LS ⁿ⁾	1 760	3 450	1 930	4 500
LZAU 20-2LS ⁿ⁾	3 900	6 550	3 650	7 350
LZAU 25-2LS ^{u)}	6 000	10 200	4 900	9 800
LZAU 30-2LS ⁿ⁾	8 650	15 000	7 800	15 600
LZAU 40-2LS ^{u)}	14 600	25 000	12 000	23 600
LZAU 50-2LS ⁿ⁾	12 900	30 000	12 000	28 000

LZAU stainless

Designations ¹⁾	Basic load ratings ²⁾			
	dynamic C		static C ₀	
–	min N	max	min	max
LZAU 12-2LS/HV6 ⁿ⁾	1 320	2 360	1 530	3 150
LZAU 16-2LS/HV6 ⁿ⁾	1 460	2 850	1 760	4 150
LZAU 20-2LS/HV6 ⁿ⁾	3 250	5 400	3 350	6 800
LZAU 25-2LS/HV6 ^{u)}	5 000	8 500	4 500	9 000
LZAU 30-2LS/HV6 ⁿ⁾	7 200	12 500	7 200	14 300
LZAU 40-2LS/HV6 ^{u)}	12 200	20 800	11 000	21 600
LZAU 50-2LS/HV6 ⁿ⁾	10 800	25 000	11 000	26 000

ⁿ⁾ Delivery time on request

^{u)} Under development, A-series linear ball bearings of that size are available

¹⁾ The designation for a LZAU linear slide with a shaft length of, for instance 600 mm, is LZAU ...-2LS x 600. Delivered as a kit of parts

²⁾ Calculated with HRC 55 due to stainless shafts

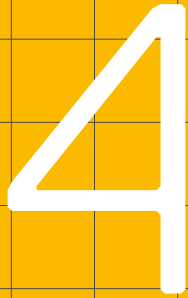

4



**Mounting, operation
and maintenance
manual**

4.1 Design rules

4.1.1 How to use linear bearings

Linear guiding systems with linear ball bearings at a minimum consist of a shaft, a housing and a linear ball bearing. They can be designed with two shafts too.

Generally, where one shaft is used, two linear ball bearings are required. Only in exceptional circumstances, e.g. when loads are very light and the parallelism of the shaft or the housing to the axis of movement is ensured by other means, is it possible to use a single linear ball bearing. In all cases where a single shaft is used it is necessary to prevent the shaft from rotating relative to the bearing.

In most applications the arrangement incorporates two shafts. This permits heavier loads and erases the necessity for special devices to prevent rotation. However, such arrangements place special demands on the parallelism of the shafts and the bores in the housings. That's why it's recommended to use original Ewellix parts.

Where very long arrangements are required, particularly if they are to be heavily loaded, it is recommended that open linear ball bearings of the LBCT, LBCF or LBHT type are used. Open linear ball bearings allow the shaft to be supported either at intervals or along its whole length.

To facilitate mounting, the shaft ends and housing bore edges should be rounded, the chamfer or lead-in angle being approximately 20°. This permits the shaft to be inserted without damaging the balls or seals of the bearing, and simplifies the insertion of the bearing in its housing.

4.1.2 Radial location

Satisfactory radial location and support for linear ball bearings can be obtained by machining the housing bore to tolerance H7. Higher demands on running behaviour or less radial clearance may call for a tighter fit in the housing, e.g. H6. The cylindricity tolerance, according to DIN EN ISO 1101, should be 1 to 2 IT grades better than the dimensional tolerance.

The following guideline values may be used for the surface roughness Ra of the housing bore:

- Diameter tolerance IT7: Ra = 1,6 µm
- Diameter tolerance IT6: Ra = 0,8 µm

Tolerances h7 or h6 are those generally recommended for the shaft. Depending on the bearing type and housing bore tolerance, the operating clearance obtained after assembly of the linear guide will be different and can be requested at your Ewellix representative.

4.1.3 Axial location

The two plastic end rings of linear ball bearings LBBR have an outside diameter slightly larger than the nominal outside diameter of the bearing. Where accelerations are small, this extra diameter will provide the requisite tightness of fit of the bearing in its housing.

Standard linear ball bearings LBCR, LBCD, LBCT, LBCF and linear plain bearings LPAR and LPAT have to be fixed in the housing with the aid of the grease fitting, designation VN-LHC (→ **chapter 3.3.7**), or similar means of attachment. Various methods are available, the main ones being described below. In each case, ensure that the bearing is not preloaded after mounting. It should always show a slight amount of clearance between the mounting surfaces in axial direction.

Axial location using retaining rings (→ **fig. 1 and fig. 2**) takes little space, enables fast mounting and dismounting and simplifies the machining of the associated components. Standard linear ball bearings are equipped with two grooves for retaining rings on the outer diameter to enable method 2. It's important to know that the spring force of the retaining ring slightly preloads the balls via the loosely held raceways. The radial clearance between the outer surface of the raceways and the housing bore remains. Use retaining rings according to DIN 471 to locate the bearing as shown in **figure 2**.

Instead of retaining rings, end plates, covers (→ **fig. 3**) or retaining plates (→ **fig. 4**) can be screwed to the housing to provide axial location for the bearing.

It is also possible to axially locate the bearing on a housing shoulder (→ **fig. 5**) or via a spacer sleeve on a neighbouring machine component.

Fig. 1

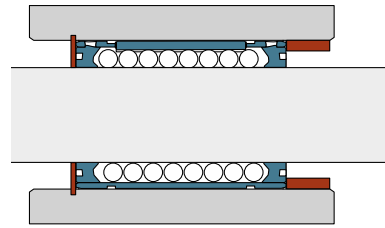

Fig. 2

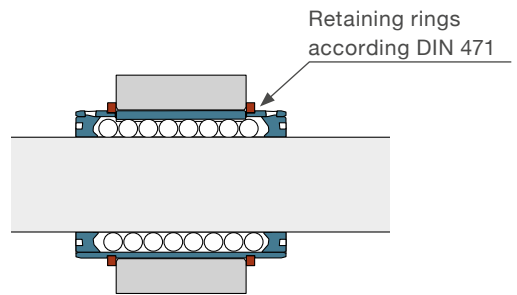

Fig. 3

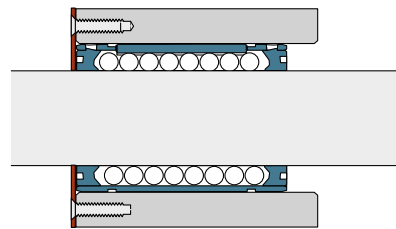

Fig. 4

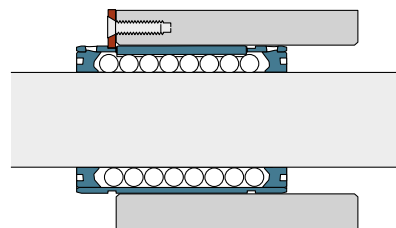
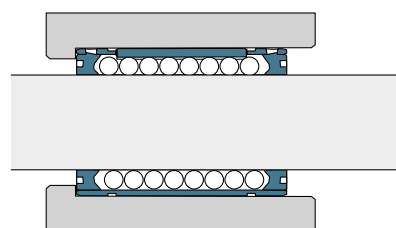

Fig. 5



4.1.4 Axial and rotational fixation

All open type linear ball bearings LBC must not only be given adequate axial location, but must be prevented from turning. This is also true for closed standard linear ball bearings which are to be mounted in a defined orientation. Therefore holes are provided in the outside diameter of the bearings in which stops can be inserted to prevent the bearing from rotating. The position and diameter of the holes in the bearing's outside diameter are shown in **table 1** to **4**. The following can be used as stops:

- Ewellix grease fittings, VN-LHC (↳ **chapter 3.3.7**)
- Grub screws according to DIN EN 27435 or DIN EN ISO 4028
- Straight pins according to DIN EN ISO 2338
- Grooved pins according to DIN EN ISO 8739 or DIN EN ISO 8744
- Slotted pins according to DIN EN ISO 8752

Be aware that the linear ball bearing is destroyed if the pin extends more than value t_1 into the bearing!

Value t_1 of D-series bearings is reduced compared to A-series bearings, so make sure to use a shorter pin in case of replacement!

Table 1

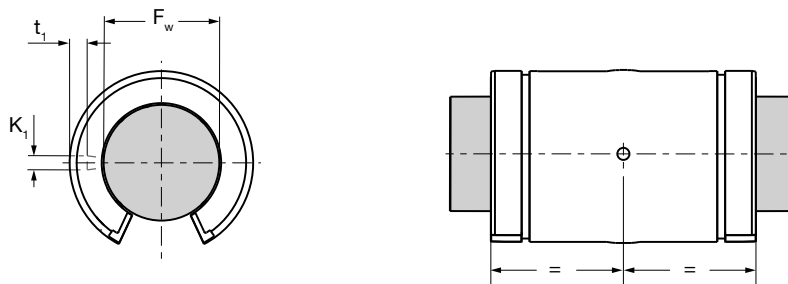

Dimensions		Appropriate grease fitting ¹⁾		Grub screws ²⁾		Pins ³⁾		Pins ⁴⁾		
F_w mm	valid for bearing type	$K1$ ⁵⁾ mm	t_1	K_2 ⁶⁾	t_2	s	Diameter mm	Diameter		
12	LBCR & LBCD closed design,	3,0	2,6	-	-	-	VN-LHC 20	M 4	3	3
16	LBCR & LBCD closed design, LBCT & LBCF open design	3,0	2,6	-	-	-	VN-LHC 20	M 4	3	3
20	LBCR & LBCD closed design, LBCT & LBCF open design	3,0	2,6	-	-	-	VN-LHC 20	M 4	3	3
sizes 12-20	LPAR & LPAT plain bearings	3,0	-	-	-	-	VN-LHC 20	M 4	3	3
sizes 25-40	LPAR & LPAT plain bearings	3,5	-	-	-	-	VN-LHC 40	M 5	3	3,5
sizes 50	LPAR & LPAT plain bearings	4,5	-	-	-	-	VN-LHC 50	M 6	4	4,5
sizes 60	LPAR & LPAT plain bearings	6,0	-	-	-	-	VN-LHC 80	M 8	6	6
sizes 80	LPAR & LPAT plain bearings	8,0	-	-	-	-	VN-LHC 80	M 8	8	8

Table 2

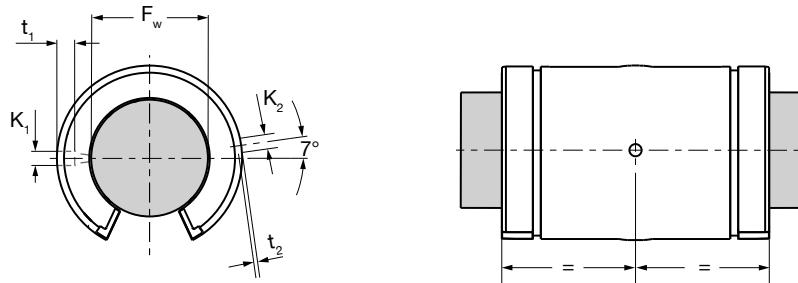

Dimensions		Appropriate grease fitting ¹⁾		Grub screws ²⁾		Pins ³⁾		Pins ⁴⁾		
F_w mm	valid for bearing type	$K1$ ⁵⁾ mm	t_1	K_2 ⁶⁾	t_2	s	Diameter mm	Diameter		
12	LBCT & LBCF open design	3,0	2,6	3,0	1,0	-	VN-LHC 20	M 4	3	3

¹⁾ Recommendations for the design of drills to mount the grease fittings are given in **chapter 3.3.7**
²⁾ Grub screws according to DIN EN 27435 or DIN EN ISO 4028.
³⁾ Straight pins according to DIN EN ISO 2338 or grooved pins - DIN EN ISO 8739 and DIN EN ISO 8744.
⁴⁾ Slotted pins - DIN EN ISO 8752
⁵⁾ For relubrication as well as location of linear bearings in Ewellix housings.
⁶⁾ Alternative borehole for location in specific housings from other manufacturers.

The use of VN-LHC grease fittings is recommended and they are used for this purpose in Ewellix linear bearing units.

The linear ball bearings LBCR 5 and LBCR 8 are without a fixation hole but are self-retaining if the temperature is limited to 60°C and mounted in housings of at least bearing length. Retaining rings are required with shorter housings.

Linear plain bearings LPAR 5 and LPAR 8 are without a fixation hole.

Table 3

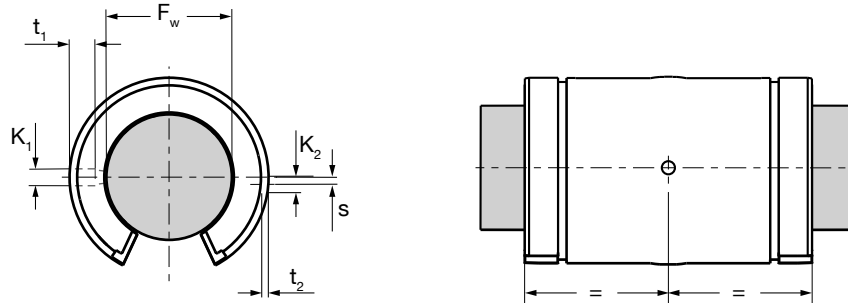

Dimensions		Appropriate grease fitting ¹⁾		Grub screws ²⁾		Pins ³⁾		Pins ⁴⁾		
F_w mm	valid for bearing type	$K1$ ⁵⁾ mm	t_1	K_2 ⁶⁾	t_2	s	-	Diameter mm	Diameter	
25	LBCR & LBCD closed design, LBCT & LBCF open design	3,5	4,5	3,0	1,4	1,5	VN-LHC 40	M 5	3	3,5

Table 4

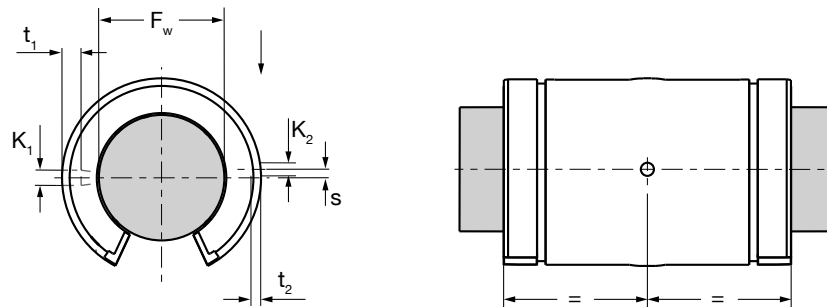

Dimensions		Appropriate grease fitting ¹⁾		Grub screws ²⁾		Pins ³⁾		Pins ⁴⁾		
F_w mm	valid for bearing type	$K1$ ⁵⁾ mm	t_1	K_2 ⁶⁾	t_2	s	-	Diameter mm	Diameter	
30	LBCR & LBCD closed design, LBCT & LBCF open design	3,5	4,5	3,0	2,3	2,0	VN-LHC 40	M 5	3	3,5
40	dito	3,5	4,5	3,0	2,7	1,4	VN-LHC 40	M 5	3	3,5
50	dito	4,5	-	5,0	-	2,5	VN-LHC 50	M 6	4	4,5
60	dito	6,0	-	5,0	-	2,5	VN-LHC 80	M 8	6	6
80	dito	8,0	-	5,0	-	2,5	VN-LHC 80	M 8	8	8

¹⁾ Recommendations for the design of drills to mount the grease fittings are given in **chapter 3.3.7**

²⁾ Grub screws according to DIN EN 27435 or DIN EN ISO 4028.

³⁾ Straight pins according to DIN EN ISO 2338 or grooved pins - DIN EN ISO 8739 and DIN EN ISO 8744.

⁴⁾ Slotted pins - DIN EN ISO 8752

⁵⁾ For relubrication as well as location of linear bearings in Ewellix housings.

⁶⁾ Alternative borehole for location in specific housings from other manufacturers.

On the heavy duty linear ball bearings LBHT there is insufficient space for holes to provide protection against turning. For this reason one of the lower raceway segments is bored to take a grub screw according to DIN EN 27435 or DIN EN ISO 4028. Dimensions and position of the bore are indicated in **table 5**. When securing LBHT bearings, care must be taken not to over-tighten these screws. If you do, excessive stress may be created, resulting in premature failure of the bearing.

If, for design reasons, none of these means can be adopted for the prevention of turning, open linear ball bearings may be retained by means of plates screwed to the housing, as illustrated in **figures 6 and 7**.

Table 5

Turning stops for LBHT linear ball bearings

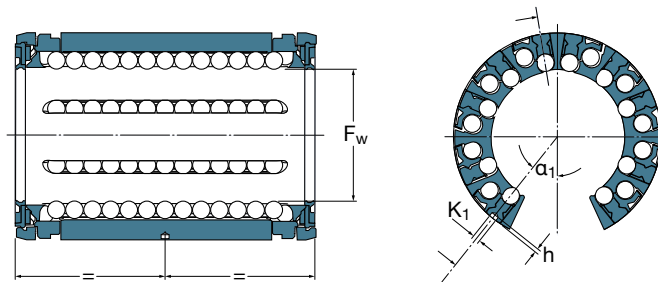

Dimensions				Appropriate grub screws ¹⁾	Designation
F _w mm	K ₁	h	α ₁ Deg		
20	2,6 ± 0,05	1,3 ± 0,2	47°	M4	Linear - ball bearing LBHT 20
25	2,6 ± 0,05	1,3 ± 0,2	55° 12'	M4	LBHT 25
30	3,6 ± 0,05	1,4 ± 0,2	39° 15'	M5	LBHT 30
40	3,6 ± 0,05	1,4 ± 0,2	38° 51'	M5	LBHT 40
50	4,1 ± 0,05	1,8 ± 0,3	39°	M6	LBHT 50

¹⁾ Grub screws according to DIN EN 27435 or DIN EN ISO 4028

Fig.6

Fig. 7

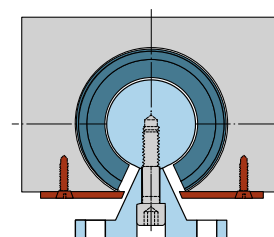
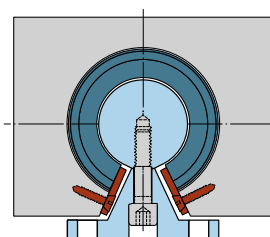

4.1.5 Sealing

In addition to correct lubrication, suitable sealing must be provided if the full life of a linear guide is to be obtained under the given operating conditions. The seals of linear ball bearings can prevent the ingress of solid contamination and moisture and retain the lubricant in the bearing. Even under the most unfavourable operating conditions, their efficiency should be maintained at all times and at a minimum of friction and wear, so that neither the bearing function nor the life of the guide is impaired. As the conditions can differ a lot from one case to another, each installation must be considered individually, such as if additional seals are required on top of the already integrated bearing seals (ordered with suffix LS or 2LS).

Various factors have to be taken into account when selecting the appropriate seal for a linear bearing, for instance the design, available space, type and severity of the contaminants, cost aspects, as well as the permissible degree of friction.

Simple and effective additional protection can be achieved by fitting a felt seal in the housing cover as shown in **fig. 8**.

Wipers as shown in **fig. 9** also offer adequate protection for the bearings in heavy duty applications.

Special sealing rings or shaft seals made of rubber or synthetic materials are another good way to try to protect the linear ball bearing from pollution. Ewellix offers a certain range of shaft seals, ↪ **chapter 3.1.3**. Further dimensions are commercially available, for example as spare parts for hydraulic cylinders. Shaft seals can be integrated into the housing cover (↪ **fig. 10**) or can be placed directly into the housing bore (↪ **fig. 11**).

It should, however, be remembered that additional seals of this kind are intended for severe cases of contamination and that they significantly add to the friction in the system.

For linear ball bearings with self-aligning capability, make sure the sealing is always in contact with the shaft.

To protect the shafts from contamination and environmental influences, it is generally recommended that the entire linear guiding arrangement including any existing drive elements such as ball or roller screws are protected with a bellow cover or if necessary, with a telescopic steel cover if the stroke length permits.

Fig. 8

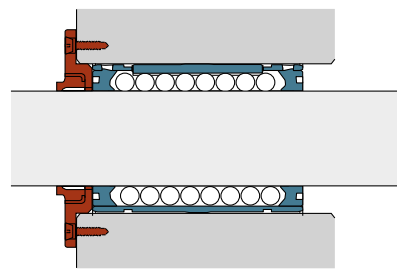

Fig. 9

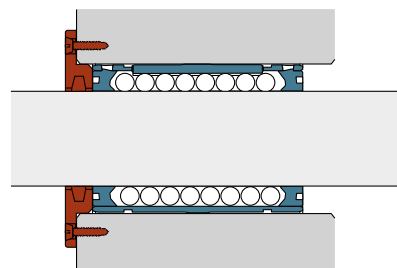

Fig. 10

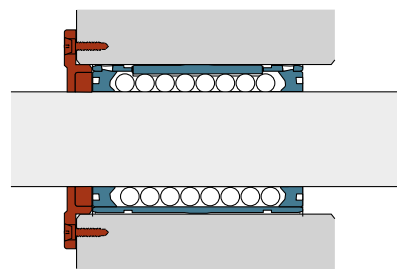
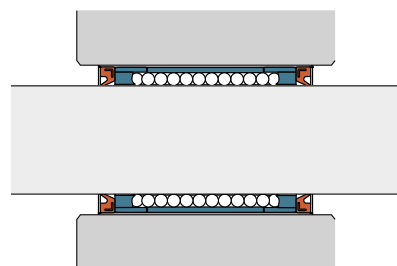

Fig. 11



4.2 Mounting of linear ball bearings

Great care and attention to cleanliness are essential when mounting Ewellix linear bearings to obtain optimum performance and to avoid premature bearing failure. Ewellix linear ball bearings are precision products and should be handled appropriately. Above all, the correct installation procedures should be followed and the appropriate tools used at all times.

4.2.1 Preparation for mounting

Mounting should be carried out in a dry, dust-free room away from metalworking or other machines producing swarf or dust. Before mounting the bearings, all the necessary parts, tools and equipment should be at hand. All parts of the linear guide (housing, shaft, etc.) should be carefully cleaned and deburred if necessary and the accuracy of form and dimensions checked against the specifications. The bearings will only perform satisfactorily if the prescribed tolerances are adhered to.

The bearings should not be removed from their original packaging until immediately before mounting, in order to avoid contamination.

Normally, the preservative with which new bearings are coated before leaving the factory should not be removed. It is only necessary to wipe it off the outer surface. Where special greases are used (e.g. a polyurea grease) which are not compatible with the preservative, the bearings must be carefully washed and dried in order to avoid any detrimental effect on the lubricating properties of the grease. The bearings must also be washed if they become dirty due to inappropriate handling (damaged packaging etc.).

4.2.2 Mounting

Ewellix linear ball bearings are easy to mount in the housing bore and little force is required. If force is needed to mount the bearings, the use of a mechanical or hydraulic press is recommended. It is advisable to use a mandrel between the press and the linear ball bearing. The mandrel, preferably of a plastic material, should be designed to provide guidance to the bearing and to give complete support to the end face so that seal damage is avoided. If the bearing has to be recessed in the housing, the mandrel may have the form shown in **fig. 12**, whereas the design in **fig. 13** should be used when the bearing has to protrude or be flush with the housing. If a puller is used (↳ **fig. 14**), ensure that the force acts centrally and it is recommended that you place a thrust bearing between the mandrel and the spindle of the puller to prevent the linear bearing from turning relative to the housing bore.

When standard linear ball bearings are to be mounted and secured against turning by the use of a grease fitting or a suitable pin, care should be taken that the attachment hole of the bearing is aligned with hole in the housing.

Direct blows to the linear ball bearing are to be avoided at all times as these would damage the seals and the cage.

Fig. 12

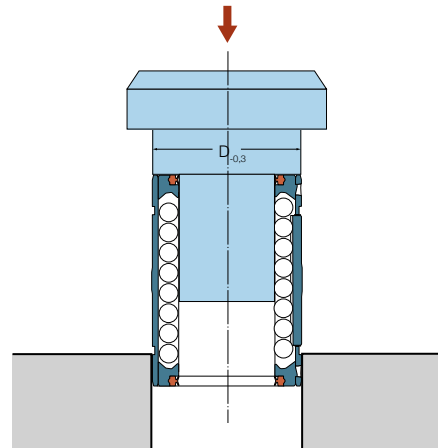

Fig. 13

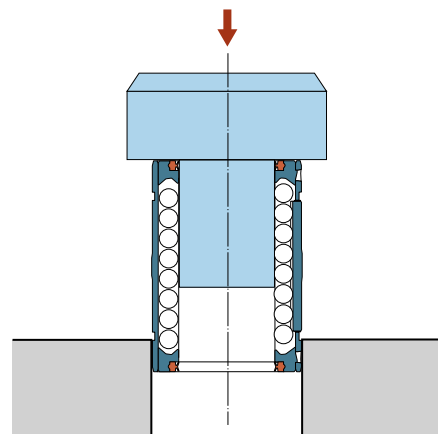
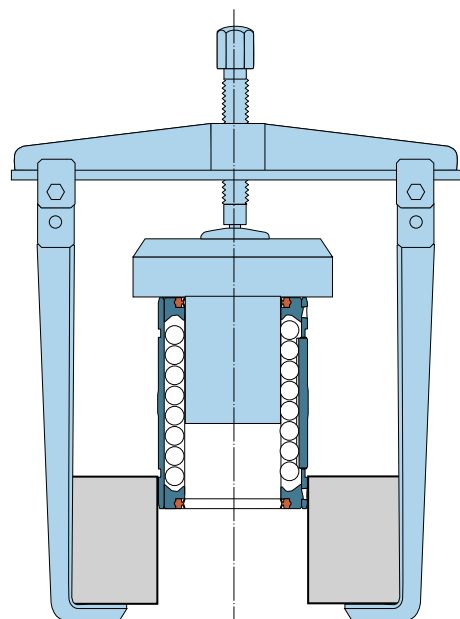

Fig. 14



4.3 Maintenance

4.3.1 Stationary conditions, shipping and storage

Linear ball bearings should be stored in a cool and dry indoor area and in its original packing, which should be kept closed until the bearing is needed for use. The indoor temperature should not exceed 30 °C (86 °F) and should remain above 0 °C (32 °F). Make sure the relative humidity of the storage area does not exceed 60 %. Do not store directly near a heat source and avoid exposure to direct sunlight. The bearings are normally coated with a rust inhibiting preservative before packing and can therefore be stored for up to four years in their original unbroken packaging. It is possible that the lubricating properties of the grease inside the bearing will deteriorate with a longer time of storage. In such cases the old grease has to be replaced by the necessary amount of fresh grease before usage. Bearings with seals, when stored for longer periods, may be found to have a higher initial starting friction than new bearings.

5

**Customer
specification sheet**

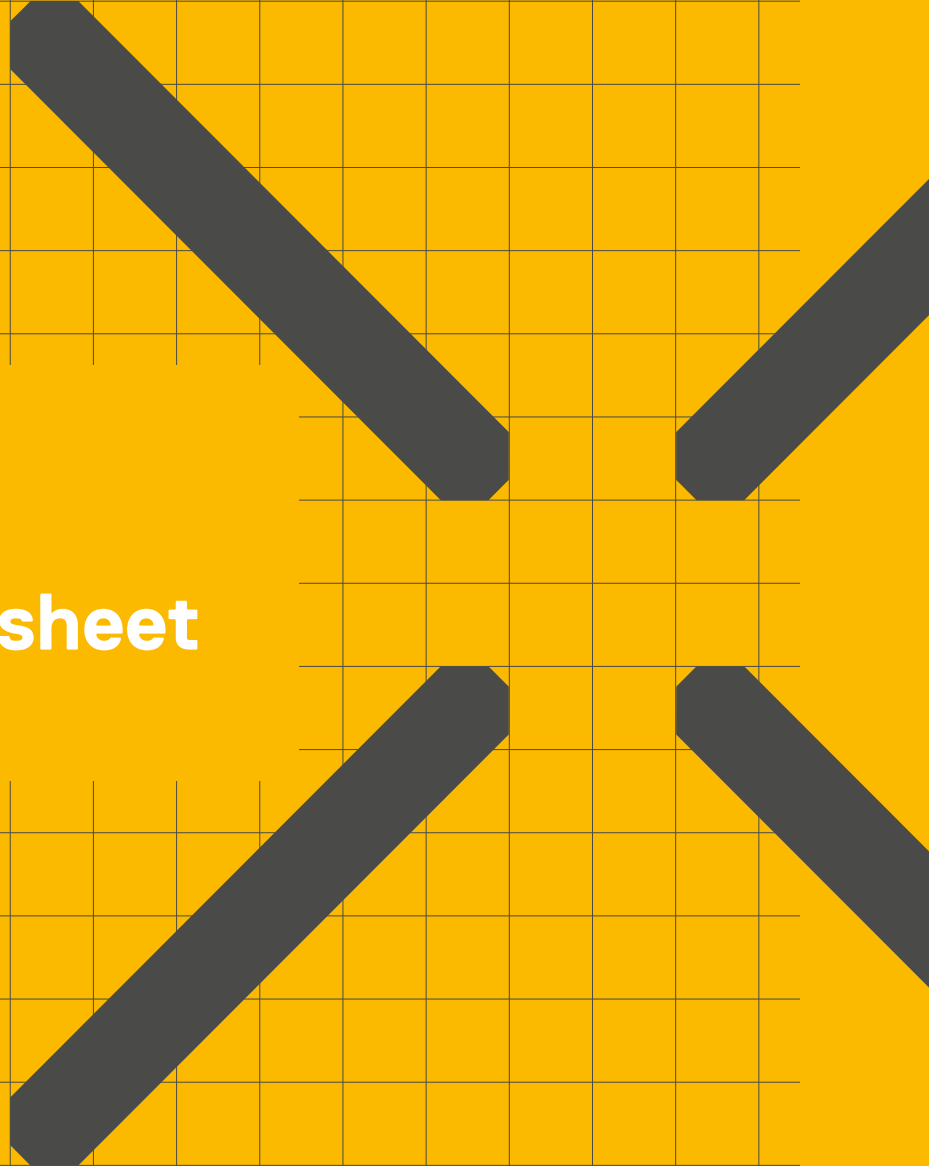

Specification sheet – Linear Ball bearing

Please complete the form with all available information and send it to your Ewellix representative or authorized distributor for product selection.

Ewellix contact	Date
-----------------	------

General information

Customer

Company		
Address 1		
Address 2		
Post code / Zip	City	State
Country		

Contact

Contact name	
Job title	
Department	
Phone (including country code)	Mobile (including country code)
Mail	

Project title

Reason for request

Current product / brand <input type="radio"/> Replacement	<input type="radio"/> New design	Description <input type="radio"/> Other
--	----------------------------------	--

Application / Industry

<input type="radio"/> Factory automation <input type="radio"/> Medical	<input type="radio"/> Food and beverage <input type="radio"/> Semiconductor	<input type="radio"/> Machine tools <input type="radio"/> Other	Description
---	--	--	-------------

Export control and Ewellix policy (mandatory to mark)

<input type="radio"/> The application is not subsidiary or part of industry of national defence and/or nuclear (also not with details of the function). The application is civil.

Commercial information

General

<input type="radio"/> One shot business <input type="radio"/> Yearly repeating business	Quantity, pcs	Batch size, pcs	Start of supply, YYYY MM DD	Target price / each	Currency
--	---------------	-----------------	-----------------------------	---------------------	----------

Application description



Product details

Product designation (if already known)

Range

- Compact range
 Standard range

Bearing type

- Linear ball bearing
 Linear plain bearing

Bearing design

- Closed design
 Open design (for supported shafts)

- Rigid (permissible shaft deflection without reduction $\pm 5'$ of arc)
 Self-aligning (permissible shaft deflection $\pm 30'$ of arc)

Needed accessories (for details see Ewellix publication Linear ball bearings and units)

Shaft

Designation

LJ ...

Length

mm

Shafting standard

ESSC ...

Housing

Designation

Single shaft block

Designation

LS ...

Tandem shaft block

Designation

LE ...

Linear ball bearings mounted as a complete system

System

Designation

LZ ...

System with drive, e.g. ball screw



ewellix.com

© Ewellix

All contents of this publication are the property of Ewellix, and may not be reproduced or given to third parties (even extracts) without permission. Although great care has been taken in the production of this catalog, Ewellix does not take any responsibility for damage or other loss resulting from omissions or typographical errors. The photo may differ slightly in appearance from the actual product. Due to continuous improvements being made in our products, the product's appearance and specifications are subject to change without notice.

PUB NUM IL-06013/1-EN-July 2020

SKF and SKF logo are trademarks of the SKF Group