

# EWELLIX

A Schaeffler Company

## Vertical axis for Universal Robots collaborative robots LIFTKIT-UR

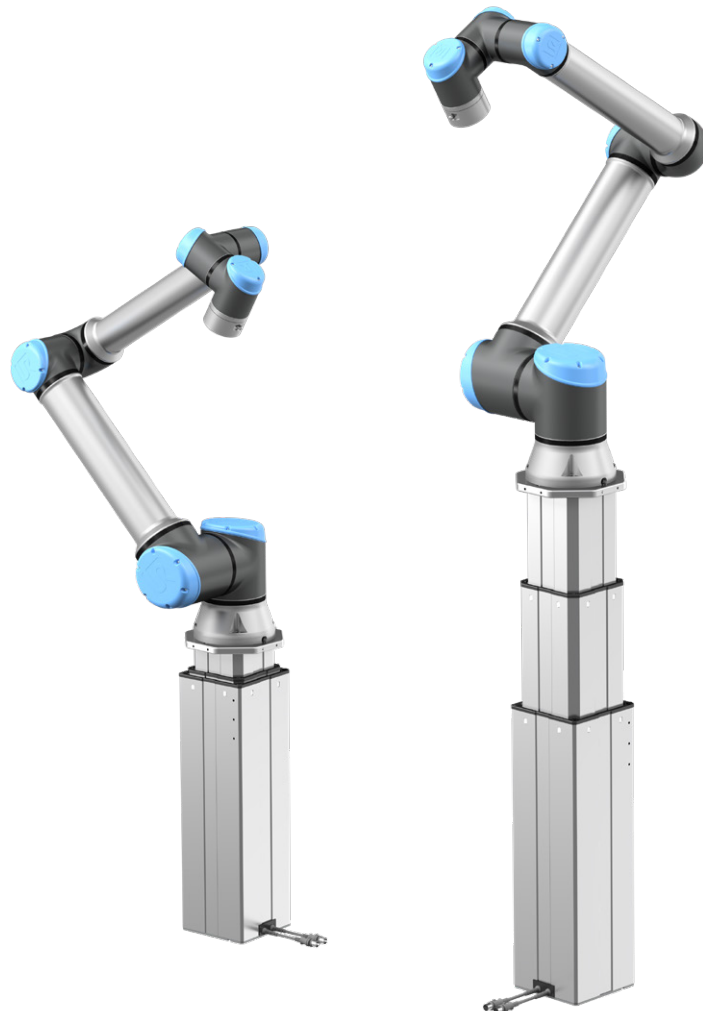

# The heritage of innovation

Ewellix is a global innovator and manufacturer of linear motion and actuation solutions. Our state-of-the-art linear solutions are designed to increase machine performance, maximise uptime, reduce maintenance, improve safety and save energy. We engineer solutions for assembly automation, medical equipment, mobile machinery, distribution and a wide range of other industrial applications.

## Technology leadership

We earned our reputation through decades of engineering excellence. Our journey began over 50 years ago as part of the SKF Group, a leading global technology provider. Our history provided us with the expertise to continuously develop new technologies and use them to create cutting edge products that offer our customers a competitive advantage.

In 2019, we became independent and changed our name to Ewellix. We are proud of our heritage. This gives us a unique foundation on which to build an agile business with engineering excellence and innovation as our core strengths.

## Global presence and local support

With our global presence, we are uniquely positioned to deliver standard components and custom-engineered solutions, with full technical and applications support around the world. Our skilled engineers provide total life-cycle support, helping to optimise the design, operation and maintenance of equipment thus improving productivity and reliability while reducing costs. At Ewellix, we don't just provide products; we engineer integrated solutions that help customers realise their ambitions.

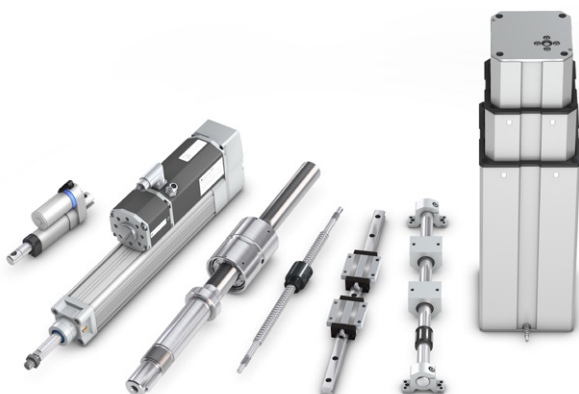

## Schaeffler Group – We pioneer motion

Ewellix is since 2023 owned by the Schaeffler Group.

As a leading global supplier to the automotive and industrial sectors, the Schaeffler Group has been driving forward groundbreaking inventions and developments in the fields of motion and mobility for over 75 years.

With innovative technologies, products, and services for electric mobility, CO<sub>2</sub>-efficient drives, Industry 4.0, digitalization, and renewable energies, the company is a reliable partner for making motion and mobility more efficient, intelligent, and sustainable.

Schaeffler manufactures high-precision components and systems for powertrain and chassis applications as well as rolling and plain bearing solutions for a large number of industrial applications.



# Benefits for handling and inspection

Ewellix provides effective solutions to complete vertical adjustment in a smart way with a wide range of “ready to mount” additional linear axis solutions. We designed them for different applications, giving to your robot an extended operation range.

Fully automated pick and place solutions are becoming a new standard with packaging stations.

A standard collaborative robot does not have such a large vertical working range. With the Ewellix LIFTKIT the base of the robot can be lifted or lowered to work at optimal position.

Stacking on pallets starts at floor level, but the stack can be up to 2 m high, and that’s where LIFTKIT can increase your packaging station efficiency.

And every time you need a repetitive operation, as end of line quality inspection, our LIFTKIT can guarantee precision and reliability to maximize your results.

Here below an application example in automotive assembly lines, with a custom LIFTKIT vertical axis for ceiling mounting installation.



# Linear axis for collaborative robots LIFTKIT-UR

## Operating range extension

- Vertical lifting of the cobot by up to 1 400 mm with compact retracted height
- Robust column design for industrial use, vibration free motion and virtually maintenance free

## Plug-and-play solution

- Hardware interface compatible with UR3, UR5, UR10 and UR16 robots and enhanced version for UR20 and UR30
- Universal Robots+ certified product
- Software control integrated with UR controller (URCaps) for easy motion programming
- Basic control option with digital I/O for all cobot manufacturers

## Cost savings and higher productivity

Cobots combined with Ewellix LIFTKIT provide a cost-effective solution to upgrade an existing assembly shop, moving from a manual handled to a fully automatized line.



## Technical data

	Unit	LIFTKIT-UR-601	LIFTKIT-UR-620
<b>Column type</b>	-	TLT	TLT
<b>Performance Data</b>			
Max. Push load	N	1 500	1 500
Max. Pull load	N	0	0
Max. static moment	Nm	3 000	3 000
Max. linear speed	mm/s	55 – 80	55 – 80
Duty cycle	-	10% (20% at 500N)	10%
<b>Mechanical Data</b>			
Screw type	-	Acme screw	Acme screw
Stroke range	mm	500 - 1 400	800
Retracted length (software controlled)	mm	Stroke/2 + 275	Stroke/2 + 475
Weight @ 0 mm stroke	kg	21	26 kg (stroke 800mm)
Δ weight per 500 mm stroke	kg	1,7	-
Robots compatibility	-	UR3, UR5, UR10, UR16, CB-Series and e-series	UR20, UR30
Cable management	-	Threads on column and interface plate to attach cable management	Threads on column and interface plate to attach cable management
<b>Electrical</b>			
Input Voltage/Current		120 VAC / 6,5 A 230 VAC / 3,3 A 24 VDC / 10 A	120 VAC / 6,5 A 230 VAC / 3,3 A 24 VDC / 10 A
I/O voltage	-	24 VDC	24 VDC
Emergency stop	-	Connection to UR safety I/O	Connection to UR safety I/O
<b>Communication</b>			
Control interface	-	URCaps plugin compatible with CB3.1 / Polyscope 3.6 or higher	URCaps plugin compatible with CB3.1 / Polyscope 3.6 or higher
Positioning, repeatability	mm	± 1	± 1
Accessible positions	-	any	any
Feedback	-	Position feedback via URCaps	Position feedback via URCaps
Soft start and stop	-	Implemented for smooth operation	Implemented for smooth operation
Software control	-	URcap	URcap
<b>Environment</b>			
Type of protection		IP40	IP40
Ambient temperature	°C	+10 to +40	+10 to +40
Max. humidity	%	85	85
Vibration	-	Stationary industrial environment	Stationary industrial environment

## Dimensional drawing

### TLT lifting column

#### Robot attachment plate

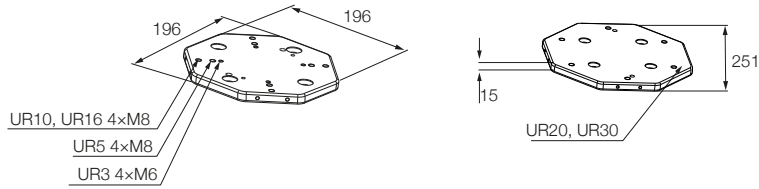

#### TLT Column

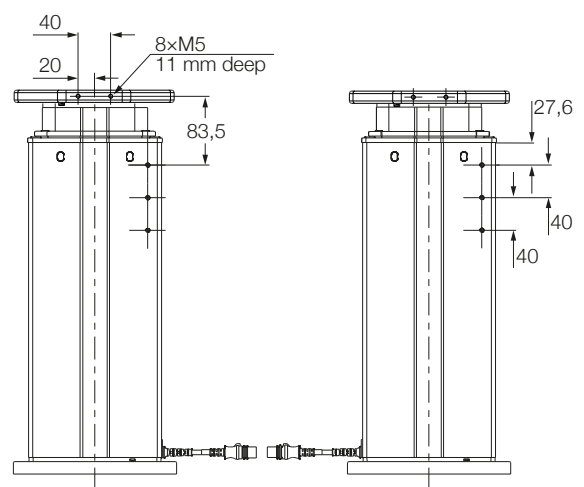
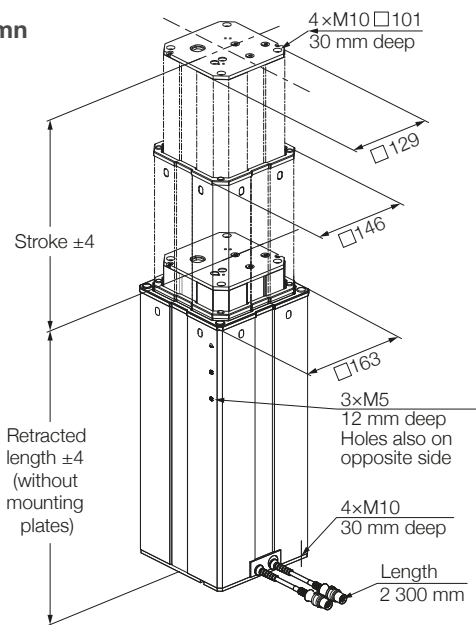

#### Bottom fixation plate

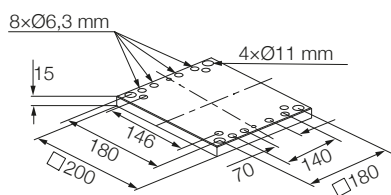

#### Controller

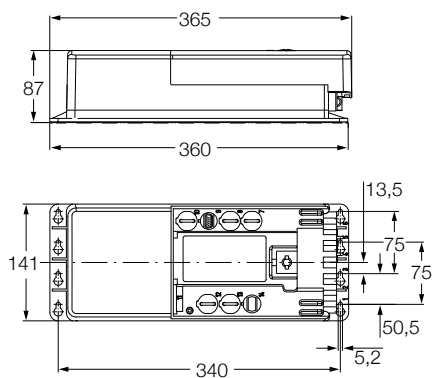

**Cable management**

Threads for cable management attachments



**Connection diagram**

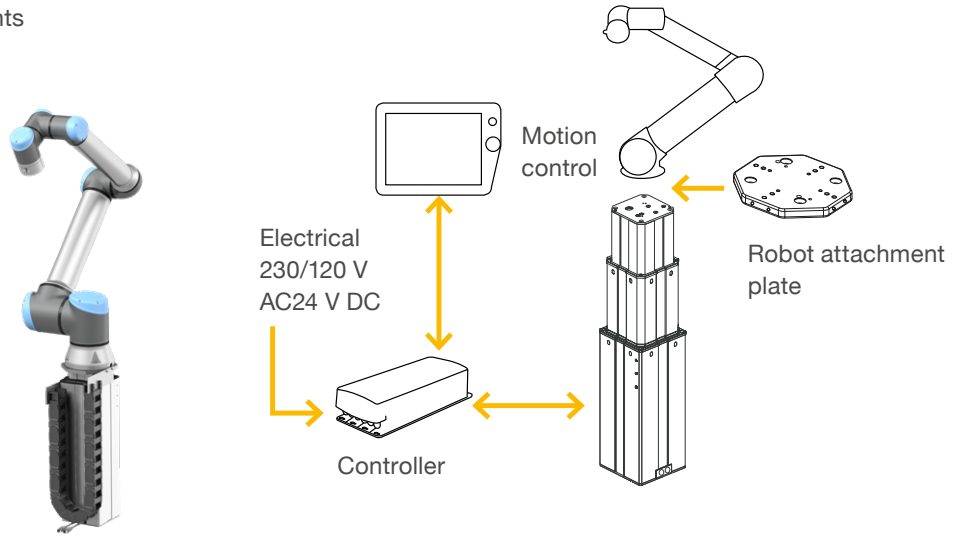

**LIFTKIT contains**

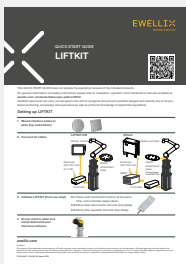

Quick Start Guide



\*Teach pendant not included



Controller

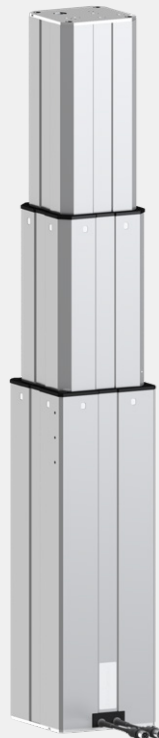

Lifting column

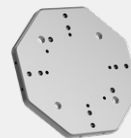

Robot attachment plate



Bottom fixation plate



Handswitch



Power cable



Controller I/O cable



RS232 cable

## Software functionality

The URCaps software for the LIFTKIT allows easy positioning access directly within the UR Polyscope environment.

### Setup

In the installation tab, the user can manually move the linear axis in both directions and define multiple user specific positions, that are accessible in programming mode.

### Motion programming

Within the UR motion program, the LIFTKIT axis is easily integrated through a URCaps command module. Simply insert this element from the structure tab at the desired position of the program. Additionally, reading and setting positions is possible through a script function.

#### Safety elements

The LIFTKIT has a range of safety elements built in to allow its integration into a robot application.

### Software updates

To download the latest software update please check on [ewellix.com/support/media-library](http://ewellix.com/support/media-library) -> [Software updates](#) -> [LIFTKIT](#)

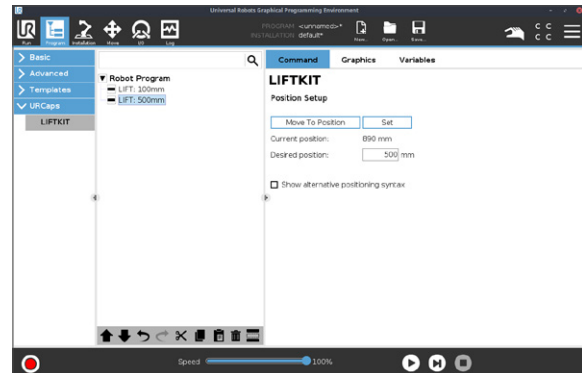
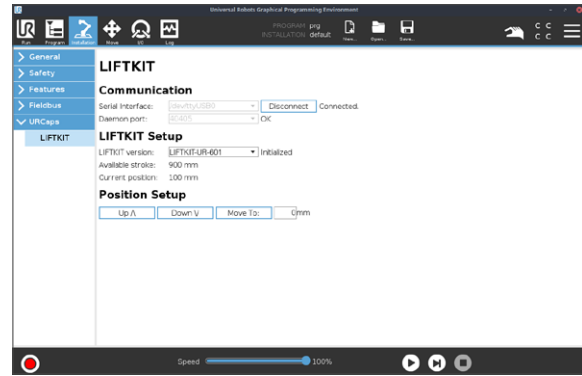

LIFTKIT software functionality

#### NOTE:

The LIFTKIT-UR is not a functional safety system compliant with EN ISO 13489-1 or IEC 62061. To integrate the LIFTKIT-UR into a functional safety chain, external safety devices have to be integrated into the overall system.

Please move the robot arm close to the center of gravity of the column when moving the LIFTKIT.

## Ordering key

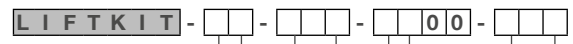

**Robot**  
UR Universal Robots

Stroke	Stroke	Retracted length	Extended length
500	500 mm	525 mm	1 025 mm
600	600 mm	575 mm	1 175 mm
700	700 mm	625 mm	1 325 mm
800	800 mm	675 mm	1 475 mm
800*	800 mm	875 mm*	1 675 mm*
900	900 mm	725 mm	1 625 mm
A00	1 000 mm	775 mm	1 775 mm
B00	1 100 mm	825 mm	1 925 mm
C00	1 200 mm	875 mm	2 075 mm
D00	1 300 mm	925 mm	2 225 mm
E00	1 400 mm	975 mm	2 375 mm

**Electrical options**

00	24 V DC
11	120 V AC / US cable
22	230 V AC / EU cable
23	230 V AC / CN cable
24	230 V AC / UK cable
25	230 V AC / CH cable

**Column type**

601	TLT
620	TLT for UR20, UR30

\* 620 TLT version is only available in 800 mm stroke, for other strokes, please contact Ewellix



**ewellix.com**

© Ewellix

All contents of this publication are the property of Ewellix, and may not be reproduced or given to third parties (even extracts) without permission. Although great care has been taken in the production of this catalog, Ewellix does not take any responsibility for damage or other loss resulting from omissions or typographical errors. The photo may differ slightly in appearance from the actual product. Due to continuous improvements being made in our products, the product's appearance and specifications are subject to change without notice.

**PUB NUM IL-07022/8-EN-March 2024**

Schaeffler and Schaeffler logo are trademarks of the Schaeffler Group.  
UR, Universal Robots and Universal Robots logo are trademarks of the Universal Robots A/S