

Vertical axis for Techman collaborative robots LIFTKIT-TM



Heritage of innovation for technology leadership

Ewellix is a global innovator and manufacturer of linear motion and actuation solutions. Today, our state-of-the-art linear solutions are designed to increase machine performance, maximise uptime, reduce maintenance, improve safety and save energy.

Technology leadership

Our journey began **over 50 years** ago as part of the SKF Group, and our history with SKF provided us with the **expertise to continuously develop new technologies** and use them to create cutting edge products that offer our customers a competitive advantage.

In 2019, we became independent from SKF and changed our name to Ewellix. **We are proud of our heritage.** This gives us a unique foundation on which to build an agile business with engineering excellence and innovation as our core strengths.

Global presence and local support

With our **global presence**, we are uniquely positioned to deliver **standard components and custom-engineered solutions**, with full technical and applications support around the world. Long standing relationships with our distributor partners allow us to support customers in a variety of different industries. At Ewellix, we don't just provide products; **we engineer integrated solutions** that help customers realise their ambitions.



1 200 employees



16 sales units



9 factories

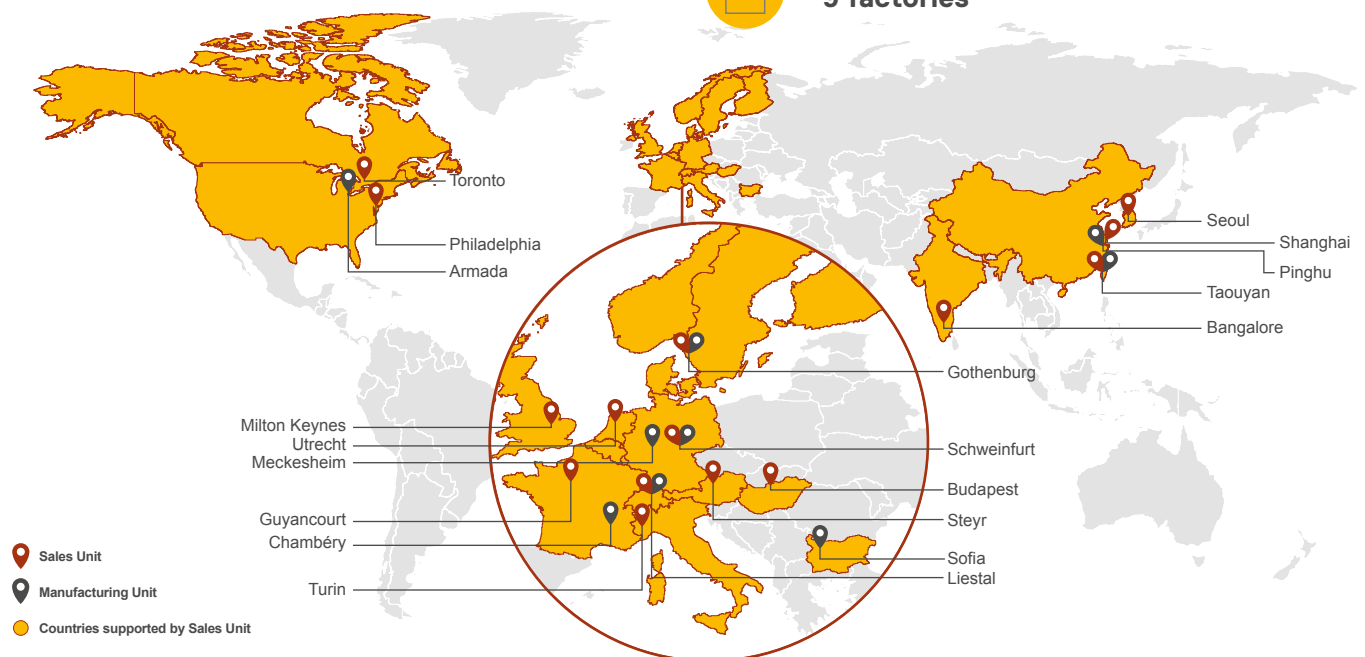

Benefits for handling and inspection

Ewellix provides effective solutions to complete vertical adjustment in a smart way with a wide range of “ready to mount” additional linear axis solutions. We designed them for different applications, giving to your robot an extended operation range.

Fully automated pick and place solutions are becoming a new standard with packaging stations.

A standard collaborative robot does not have such a large vertical working range. With the Ewellix LIFTKIT the base of the robot can be lifted or lowered to work at optimal position.

Stacking on pallets starts at floor level, but the stack can be up to 2 m high, and that’s where LIFTKIT can increase your packaging station efficiency.

And every time you need a repetitive operation, as end of line quality inspection, our LIFTKIT can guarantee precision and reliability to maximize your results.

Here below an application example in automotive assembly lines, with a custom LIFTKIT vertical axis for ceiling mounting installation.



Linear axis for collaborative robots LIFTKIT-TM

Operating range extension

- Vertical lifting of the cobot by up to 900 mm (1 400 mm on request) with compact retracted height
- Robust column design for industrial use, vibration free motion and virtually maintenance free

Plug-and-play solution

- Hardware interface compatible with TM5, TM12, and TM14 robots
- Techman certified product
- Software control integrated with TMflow for easy motion programming

Cost savings and higher productivity

Cobots combined with Ewellix LIFTKIT provide a cost-effective solution to upgrade an existing assembly shop, moving from a manual handled to a fully automatized line.



Technical data

	Unit	LIFTKIT-TM-601
Column type	-	TLT
Performance Data		
Max. push load	N	1 500
Max. pull load	N	0
Max. dynamic moment	Nm	210
Max. static moment	Nm	3 000
Max. linear speed	mm/s	80
Duty cycle	-	10% (20% at 500N)
Mechanical Data		
Screw type	-	Acme screw
Stroke range	mm	500 - 900
Retracted length (software controlled)	mm	Stroke/2 + 275
Weight @ 0 mm stroke	kg	21
Δ weight per 500 mm stroke	kg	1,7
Robots compatibility	-	TM5, TM12, TM14
Cable management	-	Threads on column and interface
	-	Plate to attach cable management
Electrical		
Input Voltage/Current	-	120 VAC / 6,5 A 230 VAC / 3,3 A
Input frequency	Hz	50-60
Input Fuse	A	10
I/O voltage	-	24 VDC
I/O current	-	max. 10 A not protected
Emergency stop	-	STO up to PLe, Cat.4
Communication		
Control interface	-	Compatible with TMflow on TM HW 3.2 or higher
Positioning, repeatability	mm	± 1
Accessible positions	-	any
Feedback	-	Position & Status
Soft start and stop	-	Implemented for smooth operation
Software control	-	TMflow software
Environment		
Type of protection	-	IP40
Ambient temperature	°C	+10 to +40
Max. humidity	%	85
Vibration	-	Stationary industrial environment

Dimensional drawing

TLT Lifting column

Robot attachment plate

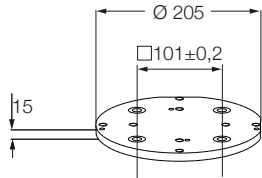

TLT Column

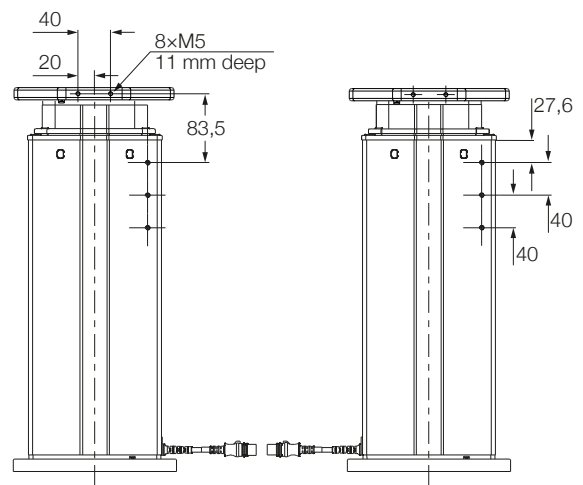
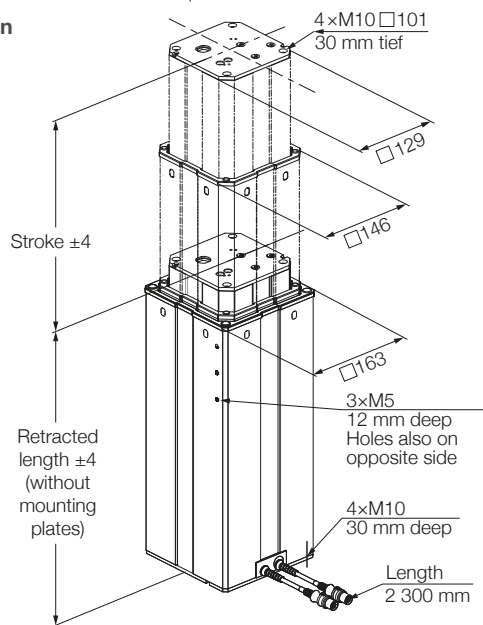

Bottom fixation plate

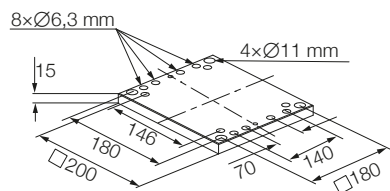

Controller

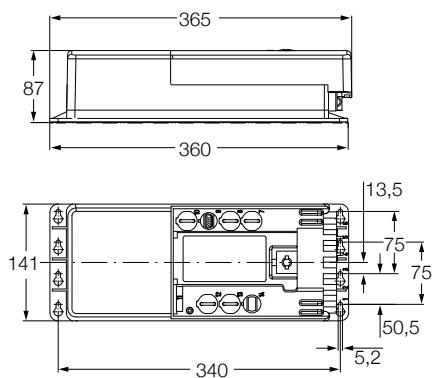

SBOX

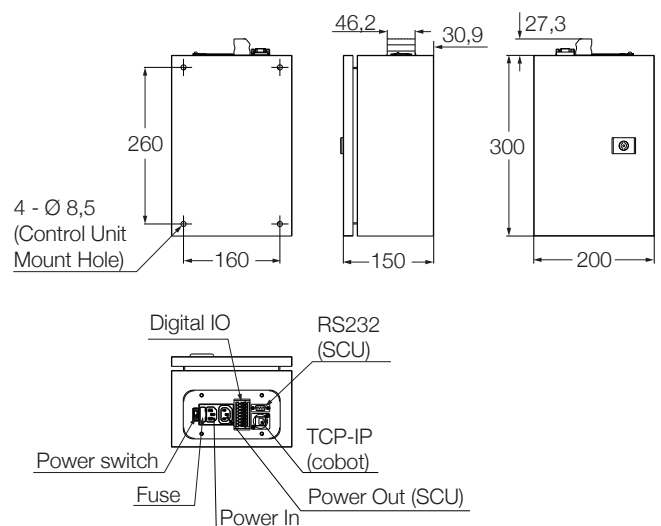

Cable management

Threads for cable management attachments



Connection diagram

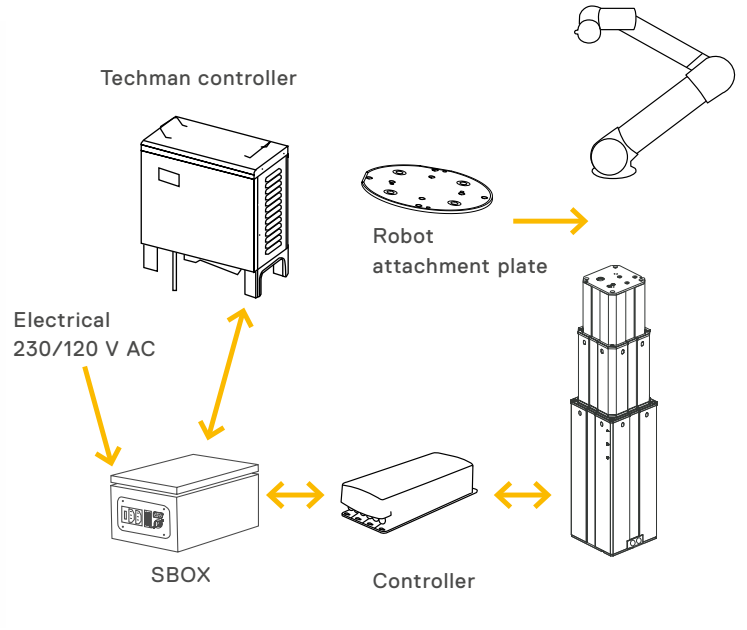

LIFTKIT contains



Quick start guide



Controller



SBOX



Lifting column



Robot attachment plate



Bottom fixation plate



Handswitch



SBOX Key



SBOX I/O cable



SBOX power cable



SBOX to controller power cable



Controller I/O cable



RS232 cable



Ethernet cable

Software functionality

The Ewellix LIFTKIT component allows customers to integrate the LIFTKIT lifting column’s capabilities with TMflow applications.

Setup & Programming:

The Ewellix LIFTKIT command component allows the set up and control the LIFTKIT in TMflow. The component can be inserted multiple times throughout a TMflow project via drag-and-drop to access multiple positions while getting feedback about current position and status.

Safety elements

The LIFTKIT has a range of safety elements built in to allow its integration into a robot application, including safety relay certified according ISO 13849-1, allowing STO up to PLe, Cat. 4

Software updates

To download the latest software update please check on ewellix.com/support/media-library -> Software updates -> LIFTKIT.

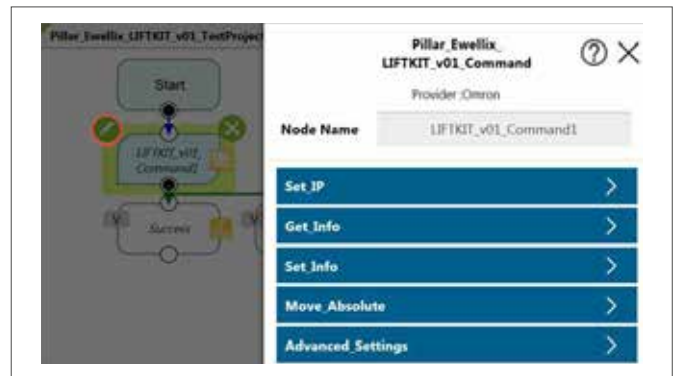
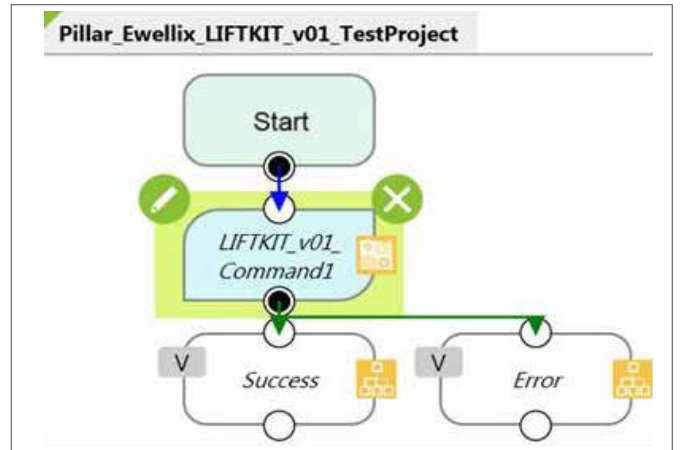

LIFTKIT software functionality

Ordering key



Robot
TM Techman

Stroke*
500 mm
600 mm
700 mm
800 mm
900 mm

Electrical options
11 120 V AC / US cable
22 230 V AC / EU cable
23 230 V AC / CN cable
24 230 V AC / UK cable
25 230 V AC / CH cable

Column type
601 TLT

* longer stroke up to 1 400 mm available on request

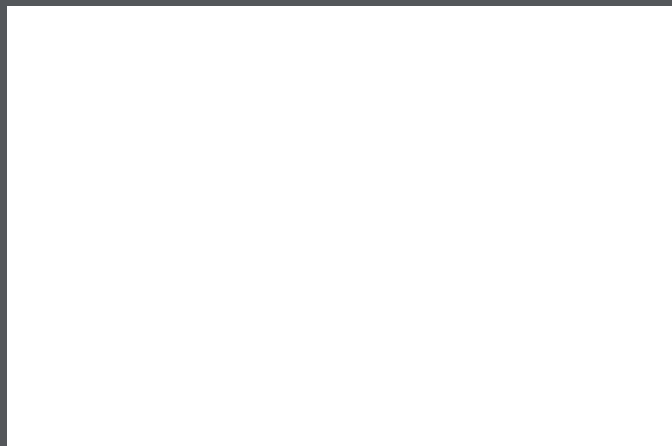

ewellix.com

© Ewellix

All contents of this publication are the property of Ewellix, and may not be reproduced or given to third parties (even extracts) without permission. Although great care has been taken in the production of this catalog, Ewellix does not take any responsibility for damage or other loss resulting from omissions or typographical errors. The photo may differ slightly in appearance from the actual product. Due to continuous improvements being made in our products, the product's appearance and specifications are subject to change without notice.

PUB NUM IL-07032-EN-June 2021

SKF and SKF logo are trademarks of the SKF Group.

Techman and Techman logo are trademarks of the Techman Corporation