

Electric cylinders CASM-100



High modularity



Long strokes



Parallel spur gearbox



Ball and roller
screw technology

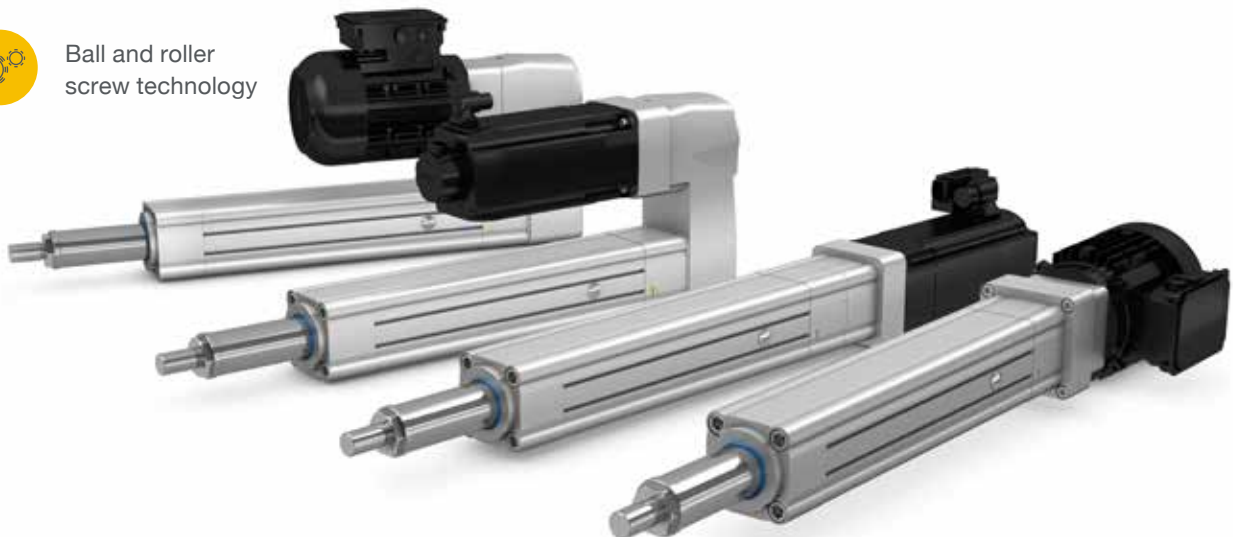

Electric cylinders

CASM-100

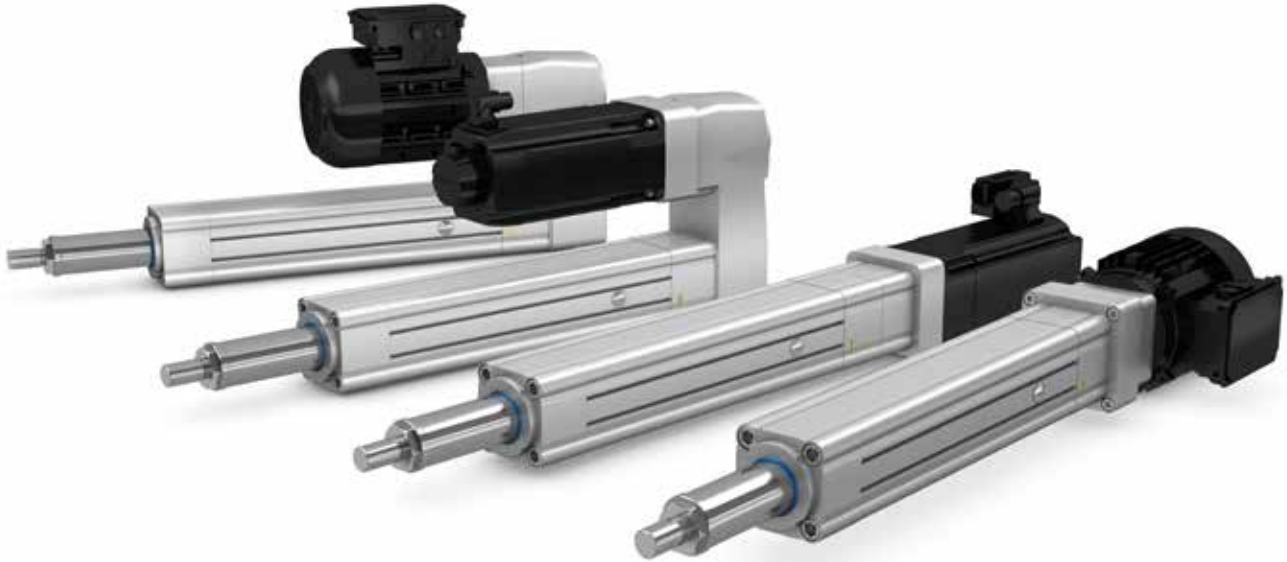

Features

- Electric cylinder with high modularity
- Ball-screws or roller-screws
- Inline and parallel gearboxes
- Standardized interfaces
- High level of precision and repeatability
- Wide range of accessories

Benefits

- For a wide range of applications with different performance and lifetime requirements
- Optimal lifetime even at very high forces
- High level of flexibility with variance of body assembly fitting most of the applications.
- Fits AC motors and servo motors
- Accurate positioning

Product description

Ewellix developed an innovative modular electric cylinder platform to address most of the applications in the automation and heavy machinery industries, mainly replacing hydraulic solutions. In this new design, instead of limiting the selection on the “linear unit - gearbox – motor” modules only, Ewellix takes it a step further. The modularity has been extended to the base component level. Within each module, the customer can select the components inside to build a custom-like solution as standard. This concept makes it possible to find the optimal solution for almost every application within its power range with the best performance/cost ratio.

To facilitate customers in defining their own actuator, Ewellix has released an online configurator on Ewellix.com, where

you can configure your optimal CASM-100 cylinder in just a few steps. Since the cylinders are assembled with standard components, any customer defined configuration will not influence the lead time.

To meet any space and performance requirements, Ewellix provides inline and parallel gearboxes as well as AC and servo motors. All motors are equipped with specific adapters to keep the same mechanical interface, independent of the selected motor type.

This standardized interface allows customers to also attach their own preferred motor, that customers are already familiar with (motor and drives).

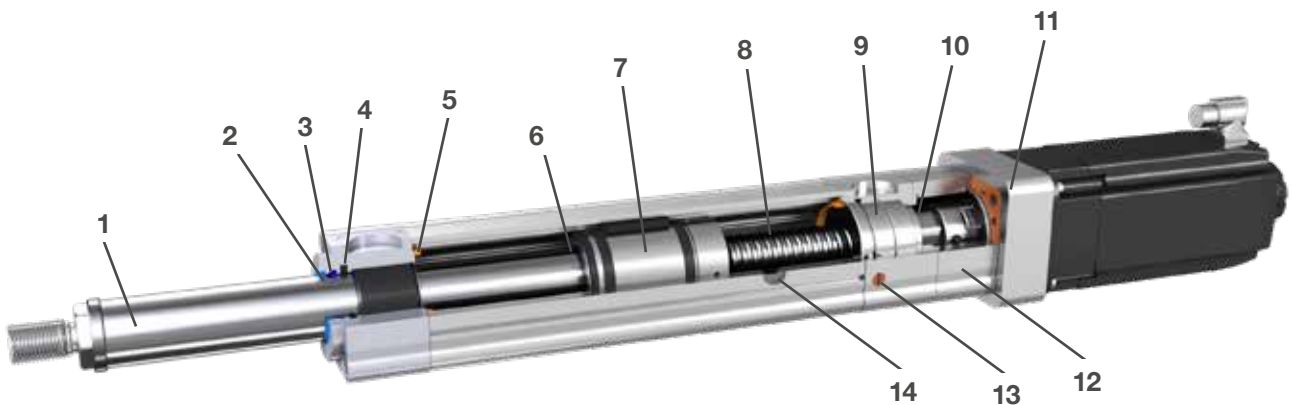

1. Push tube
2. Wiper ring
3. Solid oil ring
4. Sealing ring
5. Rubber bumper
6. Magnet ring for optional proximity sensors
7. Nut with guiding rings and anti-rotation
8. High quality ball and roller screws with low axial play and low friction
9. High quality bearings
10. Radial shaft sealing ring
11. Motor adapter and motor
12. Gearbox
13. Sinter filter for high airflow
14. Relubrication port

System overview

The CASM-100 modular system comprises different components that are connected to each other through standardized interfaces.

Each component provides a unique function for the complete system and is connected as shown below.

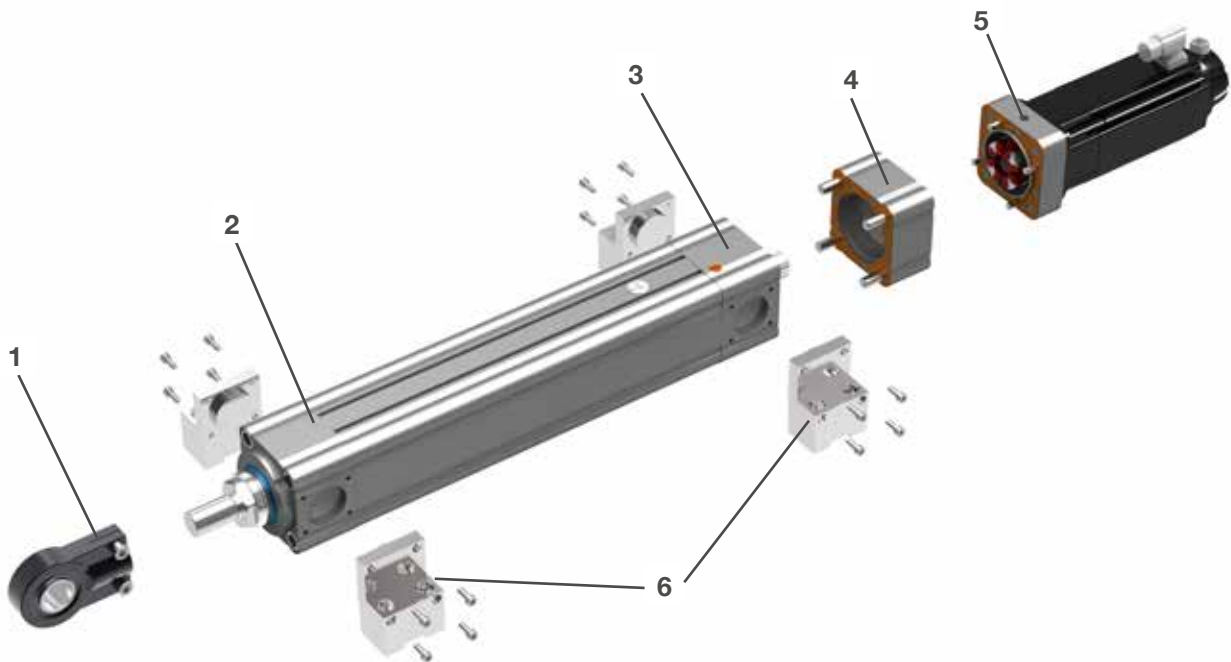

1. Front attachment: mechanical connection between the actuator and the moving part of the application. It is screwed to the push tube through the standard male thread.
2. Front housing: component that supports the push tube, through a dedicated bushing, also including the front sealing package
3. Bearing housing: component that contains the set of ball bearings that support the screw shaft
4. Gearbox: connecting module between the linear unit and the motor adapter. Is available in parallel or inline versions, with different reduction ratios
5. Motor adapter: connecting module between the gearbox and the electric motor
6. Housing attachments: actuator body attachments, connected to the fix part of the application. Depending on the attachment type, they can be installed on the different housings - front, bearing or gearbox.

Performance overview of linear units

Linear unit	F_{max} kN	F_{0max} kN	V_{max} mm/s
CASM-100-BA	23	52	260
CASM-100-BB	57	60	210
CASM-100-BC	60	60	750
CASM-100-RA	82	82	890

Performance overview of actuators

Linear unit	Motor	Adapter	F_{co} kN	F_{p0} kN	V_{max} mm/s
	–	–			
CASM-100-BA	1FK7044	inline	2,4	7	260
CASM-100-BA	1FK7064	inline	6,4	17,1	260
CASM-100-BA	1FK7086	inline	15	23	260
CASM-100-BA	1FK7105	inline	23	23	260
CASM-100-BB	1FK7044	inline	2,4	6,9	210
CASM-100-BB	1FK7064	inline	6,4	17,1	210
CASM-100-BB	1FK7086	inline	14,9	56	210
CASM-100-BB	1FK7105	inline	25,6	57	210
CASM-100-BC	1FK7044	inline	1,2	3,5	750
CASM-100-BC	1FK7064	inline	3,2	8,5	750
CASM-100-BC	1FK7086	inline	7,5	28	750
CASM-100-BC	1FK7105	inline	12,8	40	750
CASM-100-RA	1FK7044	inline	2,3	6,5	750
CASM-100-RA	1FK7064	inline	6	16,1	500
CASM-100-RA	1FK7086	inline	14,1	52,8	500
CASM-100-RA	1FK7105	inline	24,1	75,5	500

Motors

Servo motors

The Siemens motors provided by Ewellix come with a differential resolver or multi-turn encoder, a shaft-end with key-way and a holding brake. In addition, they are equipped with a Drive-CLiQ interface. A rotating plug adapter simplifies the connection and cable routing in all installation positions. For more information, please visit the following sites:



Motor:

www.siemens.com/motors

Frequency converters:

www.siemens.com/sinamics

Automation systems:

www.siemens.com/simotion

Controls:

www.siemens.com/simatic

Engineering software:

www.siemens.com/sizer

Support worldwide:

www.siemens.de/service

Motor technical data

Motor type		1FK7044-4CH71-1UH0	1FK7064-4CF71-1RB0	1FK7086-4CF71-1RB0	1FK7105-2AF71-1RB0
Designation	Unit				
Rated power (100K)	kW	1,4	2,5	3,75	8,2
Rated speed	min ⁻¹	4 500	3 000	2 000*	3 000
Rated current	A	3,9	7,6	5,7	18
Rated torque (100K)	Nm	3	8	6,5	26
Static torque (100K)	Nm	4,5	12	28	48
Peak torque	Nm	13	32	105	150
Brake holding torque	Nm	4	13	22	43
Inertia with brake	10 ⁻⁴ kgm ²	1,62	8,5	25,5	162
Weight with brake	kg	8	16,8	26	43,5
Sensor type	–	Resolver	Multiturn encoder	Multiturn encoder	Multiturn encoder

* Maximum speed is 3 000 with lower torque

Motor adapter

The modular system of CASM-100 enables the use of virtually any kind of motor.

The motor adapter module makes your motor fit the entire CASM-100 range, independent of the configuration. In fact, thanks to the standardized mechanical interface, this module can be directly attached to any inline or parallel gearbox. Sealings, screws and half coupling parts are included in the package. Each motor adapter is provided with blind threaded hole M12 to screw an eye bolt for easier actuator handling.

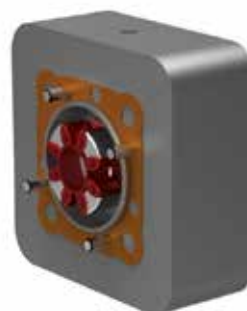

Dimensional drawing

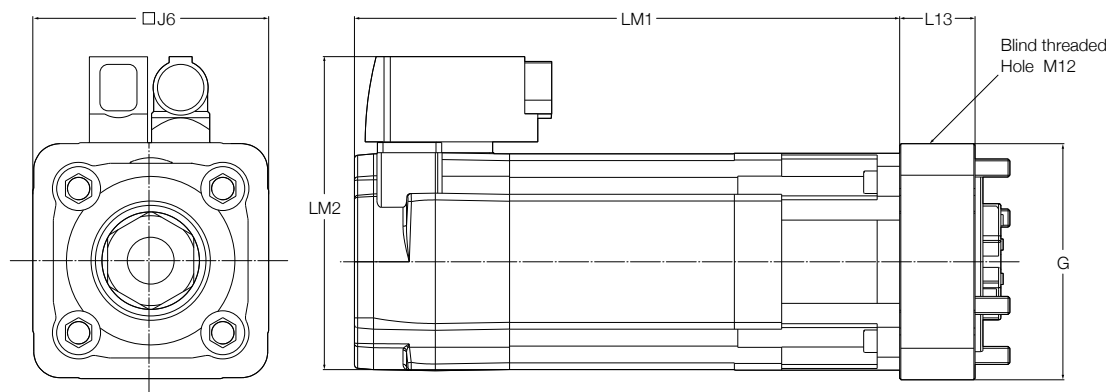

	Motor			Motor adapter	
	LM1	LM2	J6	G	L13
-	mm				
CAM-MS-B0-A11	242,5	139,5	□ 96	□ 105	45,5
CAM-MS-B0-A12	302,5	167,5	□ 126	□ 125	55,5
CAM-MS-B0-A13	309,5	216,5	□ 155	□ 139	63,5
CAM-MS-B0-A14	340	253	□ 192	□ 192,5	85,5

Third party motors

In order to attach your preferred motor to the gearbox, Ewellix offers motor adapter flanges for the most common motor types. If your motor does not fit the following specifications, please contact Ewellix.

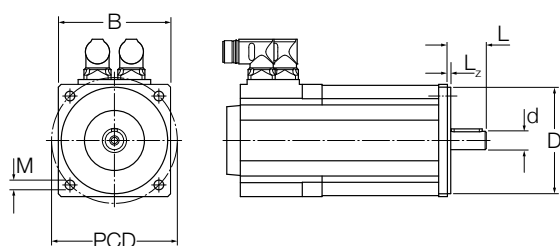

Table 1

Type	D [mm]	PCD [mm]	L [mm]	M	B [mm]	L _z [mm]	d [mm]
AA1	80	100	40	M6	≥ D + 6	< 7	19
AA2	110	130	50	M8	≥ D + 6	< 7	24
AA3	130	165	58	M10	≥ D + 6	< 7	32
AA4	180	215	80	M12	≥ D + 6	< 7	38
CC1	80	100	40	M6	≥ D + 6	< 7	16
CC2	110	130	40	M8	≥ D + 6	< 7	19
CC3	130	165	50	M10	≥ D + 6	< 7	24
CC4	70	90	40	M5	≥ D + 6	< 7	19
CC5	110	145	55	M8	≥ D + 6	< 7	22

Ordering key



Type

- A Interface according to IEC AC XX B14A
- S Interface according to **table 1** (↳ **page 6**)

Delivery

Motor supplied and mounted by Ewellix

- B0-A11 Siemens 1FK7044-4CH71-1UH0
- B0-A12 Siemens 1FK7064-4CF71-1RB0
- B0-A13 Siemens 1FK7086-4CF71-1RB0
- B0-A14 Siemens 1FK7105-2AF71-1RB0
- B0-A61 Siemens 1LE1001-0CA32-2KB4-Z=F01+F11+G11
- B0-A62 Siemens 1LE1001-0CB32-2KB4-Z=F01+F11+G11
- B0-A63 Siemens 1LE1003-0DA32-2KB4-Z=F01+F11+G11
- B0-A64 Siemens 1LE1003-0DB32-2KB4-Z=F01+F11+G11
- B0-A65 Siemens 1LE1003-0EA02-2KB4-Z=F01+F11+G11
- B0-A66 Siemens 1LE1003-0EB02-2KB4-Z=F01+F11+G11
- B0-A67 Siemens 1LE1003-1AA42-2KB4-Z=F01+F11+G11
- B0-A68 Siemens 1LE1003-1AB42-2KB4-Z=F01+F11+G11

Motor adapter only

- 00-AA1 Siemens 1FK7044 series
- 00-AA2 Siemens 1FK7064 series
- 00-AA3 Siemens 1FK7086 series
- 00-AA4 Siemens 1FK7105 series
- 00-AC1 IEC AC 71 B14A
- 00-AC2 IEC AC 80 B14A
- 00-AC3 IEC AC 90 B14A
- 00-AC4 IEC AC 100 B14A
- 00-XXX Customized flanges, dimension see table on **page 6**

Customer option

- 000 No option

Gearboxes

Inline gearbox

Inline gearboxes consist of a housing which fits on one side to the linear unit and on the other side to the motor adapter with the matching coupling. The coupling can be pushed on the shaft of the linear unit and locked by a screw. The counterpart of the coupling is delivered with the motor adapter.

The inline gearbox transmits the motor torque (max. 150 Nm) directly to the linear unit with a gear ratio 1:1 and is maintenance-free.



Dimensional drawing

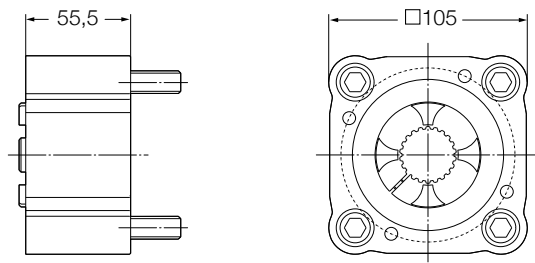

All dimensions in mm

Complete actuator

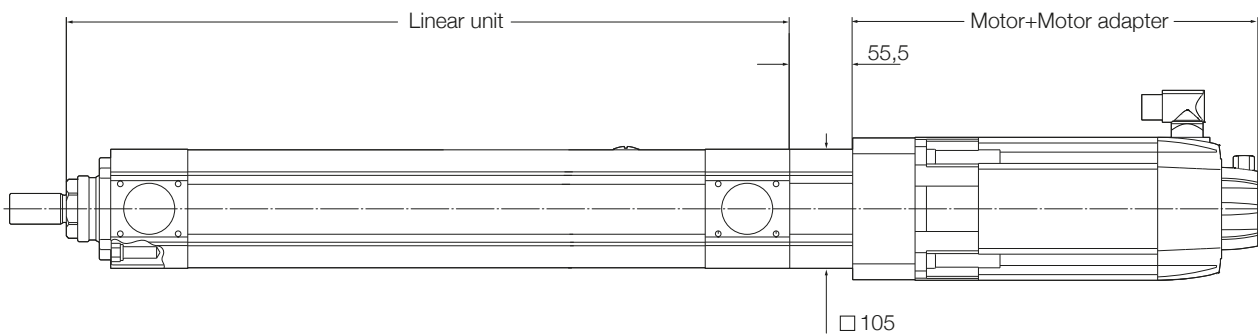

All dimensions in mm

Parallel gearbox

Parallel gearbox consists of one housing which fits on one side to the linear unit and on the other side to the motor adapter with the matching coupling. The coupling is already mounted on the input shaft of the gearbox and locked by a screw. The counterpart of the coupling is delivered with the motor adapter.

The parallel gearbox transmits the motor torque through three stage spur gear directly to the linear unit (max. output torque 300 Nm). Three gear ratios are available and it is maintenance free.



Technical data

Gearbox type		CAM-GS-CBA-XX	CAM-GS-CCA-XX	CAM-GS-CDA-XX
Short designation	Unit			
Type	–	Parallel	Parallel	Parallel
Gear reduction	–	3,89	9,82	24,95
Nominal output torque	Nm	100	100	100
Max. output torque	Nm	300	300	300
Max. input power	W	3 000	3 000	3 000
Max. input speed	r/min	4 500	4 500	4 500
Efficiency	%	85	85	85
Weight	kg	9	9	9
Length	mm	98,5	98,5	98,5

Manual override

The parallel gearbox has a manual override as built-in functionality. The gearbox can be manually operated through a hexagonal key located on the gearbox motor axis. As standard, the access to this key is covered by a plate (↳ fig. 1). On request, it's possible to have a round opening for direct access (↳ fig. 2) or to mount an electromagnetic brake (↳ fig. 3).

Speed limiting centrifugal brake

When safety is non-negotiable, a centrifugal brake (↳ fig. 4) can be a useful device. It is recommended together with an electro-mechanical brake on the motor. When releasing such a brake, the applied load may cause a rapid retraction of the machine, if no centrifugal brake is used. A centrifugal brake can be adjusted to the application in order to limit the retracting speed to a safe value. The centrifugal brake is mounted similar to an electromagnetic brake (↳ fig. 3). The following table give parameters example:

Engagement speed	n_eng	2 200 rpm ± 150 rpm
Torque	Tk	10 Nm @ 2 800 rpm ± 150 rpm

Fig. 1



Fig. 2



On request

Fig. 3



On request

Fig. 4



Dimensional drawing

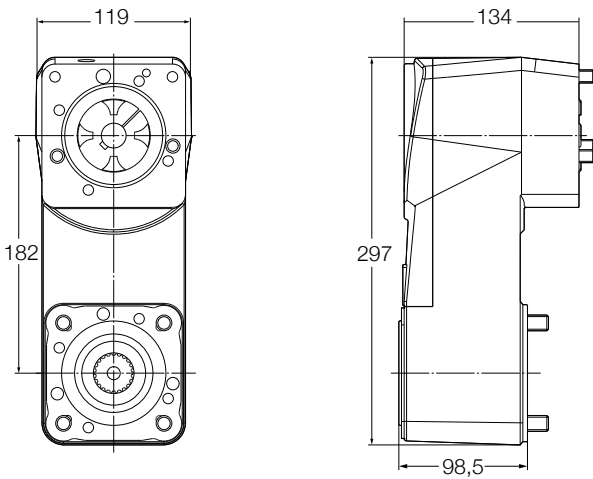

All dimensions in mm

Complete actuator

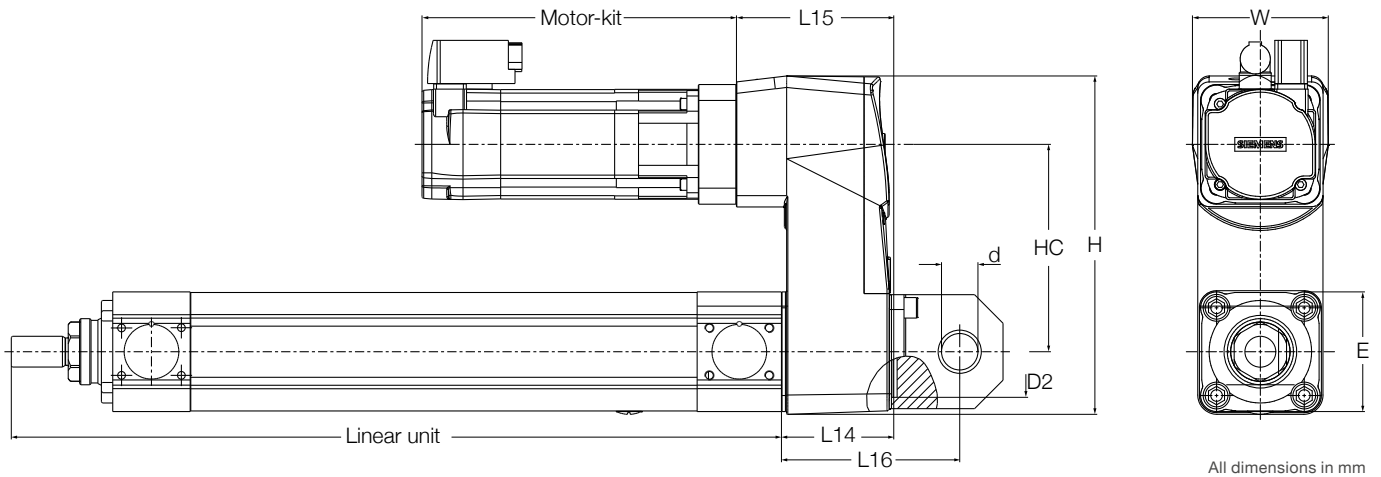

All dimensions in mm

Gear type	H	HC	L14	L15	L16	d ¹⁾	D2	W	E
CAM-GS-CXX-XX	297	182	98,5	138	156,5	Ø32 ^{-0,01 +0,085}	Ø80 ^{0 -0,1}	119	□ 105

¹⁾ Recommended shaft tolerance: f7

Rear attachment option

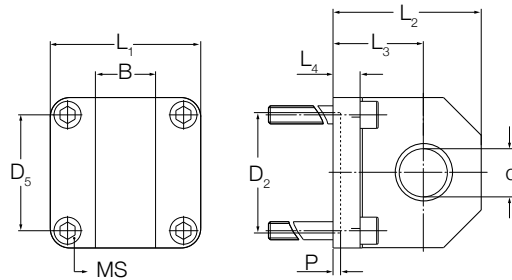

Ordering key
ZBE-377921

Type	MS	d ¹⁾	B	L ₁	L ₂	L ₃	L ₄	D ₂	P	D ₅	m
-	-	mm									kg
ZBE-377921	M12 × 140	Ø32 ^{-0,01 +0,085}	40	□ 100	98	60	11	Ø80 ^{+0,1 +0,2}	5	□ 77	3

¹⁾ Recommended shaft tolerance: f7

Ordering key

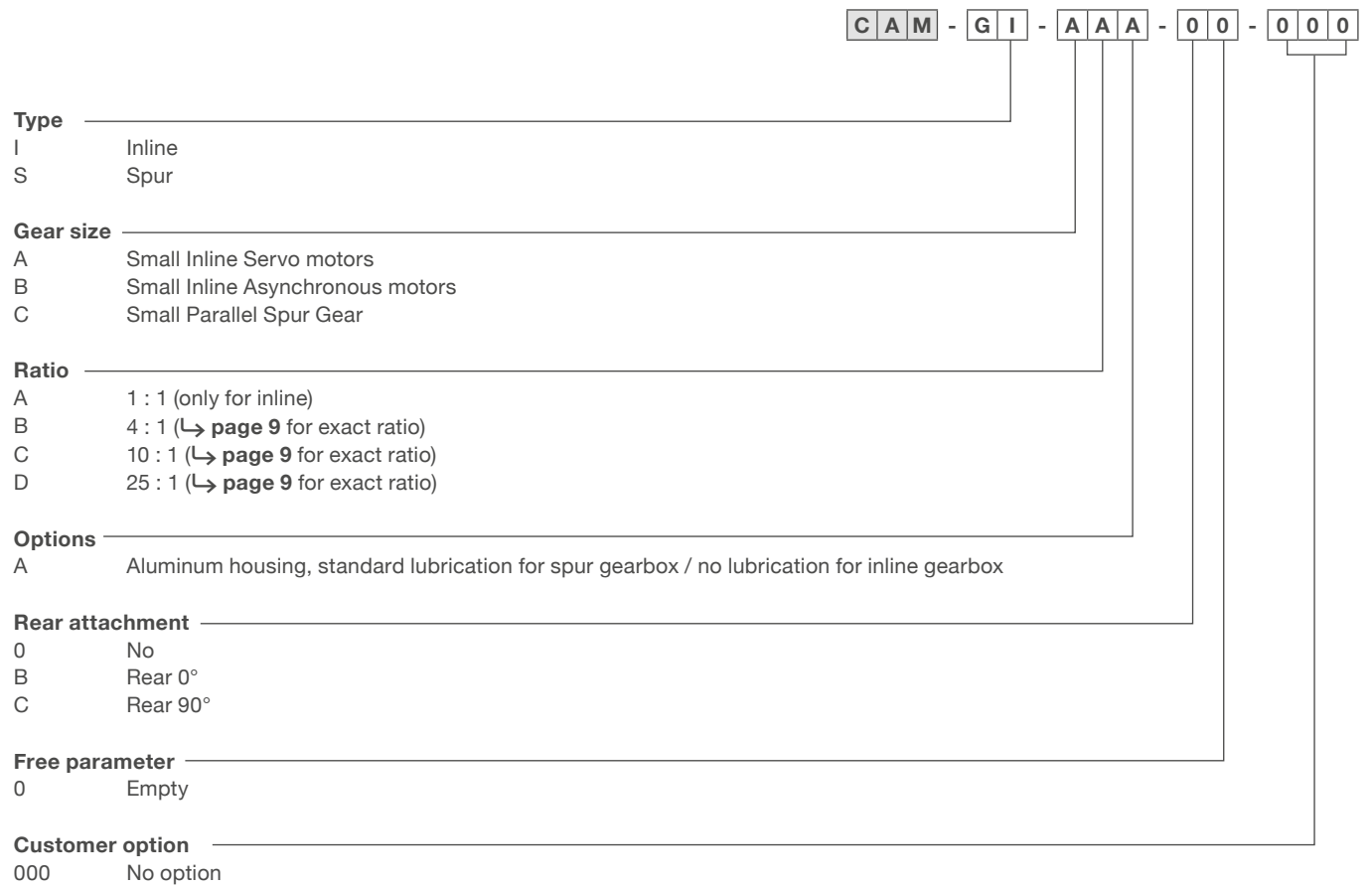

Mounting position parallel gearbox rear attachment

The 0° reference for the parallel gearbox rear attachment is the gearbox itself. The rear attachment can be turned in 90° step (↳ **fig. 4**).

Gearbox orientation

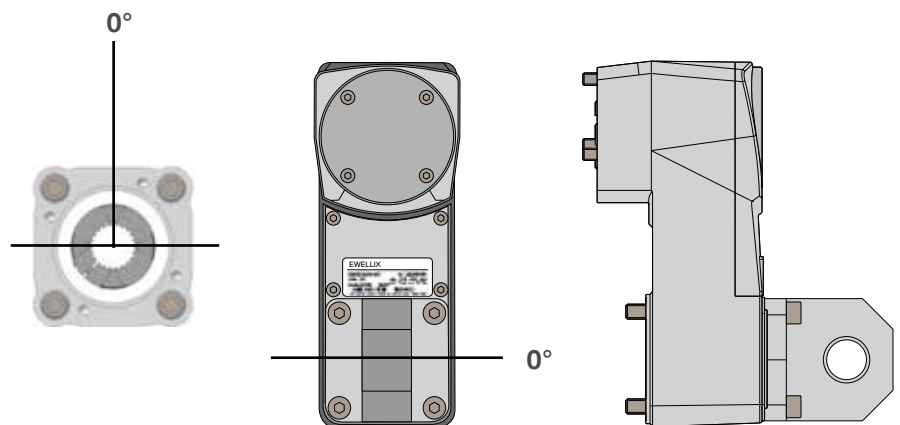

Fig. 4

Examples of linear unit, parallel gearbox and IEC AC motor combinations

The table below is a guidance to understand the performance levels that can be reached by using CAM-GS gearbox with standard IEC AC asynchronous motors, in terms of maximum dynamic axial force and linear speed.

In particular, by selecting the desired force and speed range, it's possible to quickly see which combination of screw, gearbox and asynchronous AC motors fulfil the application needs. This is a generic guidance, while the detailed performance values of each mentioned combination should be calculated.

Max. dynamic axial force [kN]

82	D (i=24,95) RA A66	D (i=24,95) RA A68				Spur gear ratio Ball or roller screw type Selected AC motor
60	D (i=24,95) BB/RA A64	D (i=24,95) BB/RA A65				
48	D (i=24,95) BB/RA A64	D (i=24,95) BB/RA A63	C (i=9,82) BB/RA A67			
34	D (i=24,95) BB/RA A62	D (i=24,95) BB/RA A63	C (i=9,82) BB/RA A67			
23	D (i=24,95) BB/RA A62	D (i=24,95) BB/RA A61	C (i=9,82) BB/RA A65	B (i=3,89) BB/RA A68		
16	D (i=24,95) BB/RA A62	D (i=24,95) BB/RA A61	C (i=9,82) BB/RA A63	B (i=3,89) BB/RA A68		
11	D (i=24,95) BA/BB/RA A62	C (i=9,82) BA/BB/RA A61	C (i=9,82) BA/BB/RA A63	B (i=3,89) BA/BB/RA A66	B (i=3,89) BC A68	
8	D (i=24,95) BA/BB/RA A62	C (i=9,82) BA/BB/RA A62	C (i=9,82) BA/BB/RA A61	B (i=3,89) BA/BB/RA A64	B (i=3,89) BC A68	B (i=3,89) BC A67
0						
	5 to 10	11 to 20	21 to 40	41 to 80	81 to 160	161 to 300
	Linear speed [mm/s]					

IEC AC Motors

The Siemens SIMOTICS low-voltage electric motors provided by Ewellix comes with a holding brake and PTC thermistor as standard.

It is a SIMOTICS GP 1LE1 self-ventilated aluminium motor with standard terminal box.

In addition, the motors are equipped with a two channel rotary pulse encoder as feedback.

Motor type ¹⁾ Designation	Size	Type	Rated power kW	Rated speed RPM	Rated current A	Rated torque Nm	Efficiency level	Motor weight kg	Motor inertia kgm ²	Brake inertia kgm ²
A61	IEC-71-2	2 poles / with encoder	0,55	2850	1,34	1,8	IE2	7	0,00045	0,000013
A62	IEC-71-4	4 poles / with encoder	0,37	1410	0,99	2,6	IE2	7	0,00095	0,000013
A63	IEC-80-2	2 poles / with encoder	1,1	2885	2,25	3,6	IE3	12	0,0013	0,000045
A64	IEC-80-4	4 poles / with encoder	0,75	1450	1,75	4,9	IE3	14	0,0029	0,000045
A65	IEC-90-2	2 poles / with encoder	2,2	2910	4,2	7,2	IE3	19	0,0031	0,00016
A66	IEC-90-4	4 poles / with encoder	1,1	1440	2,4	7,3	IE3	16	0,0036	0,00016
A67	IEC-100-2	2 poles / with encoder	3	2920	5,6	9,8	IE3	26	0,0054	0,00036
A68	IEC-100-4	4 poles / with encoder	2,2	1465	4,4	14,3	IE3	30	0,014	0,00036

¹⁾ Voltage 400 VΔ, 50Hz

Example

Selected performance values

- Max dynamic axial force: = 34 kN
- Linear speed: = 11 - 20 mm/s

Resulting combination

- Gear reduction: 24,95
- Screw type: Ball screw or roller screw
- Screw diameter: 40 mm (ball screw) or 30 mm (roller screw)
- Screw lead: 10 mm
- Motor type: Asynchronous AC
- Motor size: A63

Complete actuator combinations

The built-in modularity of the CASM-100 actuator allows customers to create tailor-made solutions through a vast number of standard components.

Considering the different types and sizes of screws, gear-boxes, motors, push tubes, bearing units, sealing kits and attachments available, several hundreds of combinations are possible.

Each of them can deliver a unique performance to fulfill even the most demanding application requirements.

For that reason, the following pages are presenting data-sheets only or the linear units for one of the possible actuator combinations (i.e. linear units with 4 screws - inline adapter - servo motors), as an example.

To create the optimal actuator combination for your application, the CASM-100 configurator is the best supporting tool. The software is available on Ewellix website in the section CASM-100 CONFIGURATOR.



Manuals

Supporting documents are available for download on ewellix.com

- operating manual

3D models

Product configurators for 3D models are available on ewellix.com



Operating manual

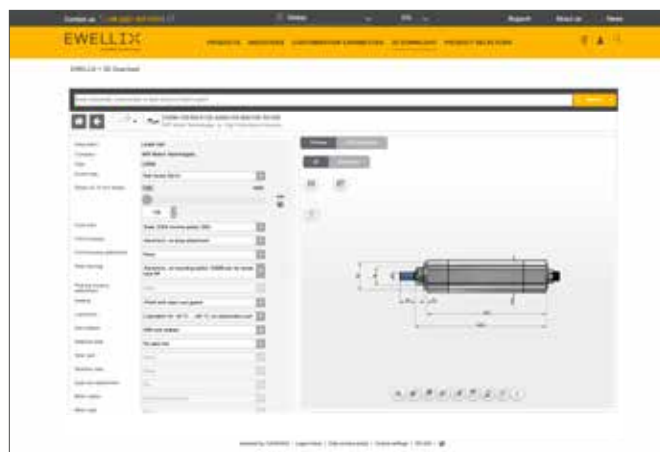

3D model configurator

CASM-100

Linear unit



Technical data

Designation	Symbol	Unit	CASM-100-BA	CASM-100-BB	CASM-100-BC	CASM-100-RA
Performance Data						
Max. dynamic axial force ¹⁾	F_{max}	kN	23	57	60	82
Max. dynamic axial force L10 ²⁾	F_{L10}	kN	22	57	60	50
Max. static axial force	F_{0max}	kN	52	60	60	82
Dynamic load capacity	C	kN	27,1	71	41,3	106
Maximum torque to reach F_{max}	T_{max}	Nm	43	107	225	163
Max. linear speed	v_{max}	mm/s	260	210	750	890
Max. rotational speed	n_{max}	1/min	1 560	1 260	2 250	5 340
Max. acceleration	a_{max}	m/s ²	6	6	12	12
Duty cycle	D_{unit}	%	100	100	100	100 ⁵⁾
Mechanical Data						
Screw type	–	–	Ball screw	Ball screw	Ball screw	Roller screw
Screw diameter	d_{screw}	mm	32	40	40	30
Screw lead	p_{screw}	mm	10	10	20	10
Lead accuracy	–	–	G9	G9	G9	G5
Stroke ^{3) 4)}	s	mm	50...2 000	50...2 000	50...2 000	50...1 000
Internal overstroke each side	s_0	mm	2	2	2	2
Backlash	$s_{backlash}$	mm	0,2	0,2	0,2	0,2
Efficiency	η_{lu}	%	> 85	> 85	> 85	> 80
Inertia @ 0 mm stroke	J_{lu}	kgm ²	0,00041	0,00051	0,00051	0,00045
Δ Inertia per 100 mm	ΔJ	kgm ²	0,000064	0,000144	0,000138	0,000063
Weight @ 0 mm stroke	m_{lu}	kg	11	12,7	12,3	12,5
Δ weight per 100 mm	Δm	kg	2,4	2,7	2,7	2,4
Environment						
Ambient temperature	$T_{ambient}$	°C	–20...+50	–20...+50	–20...+50	–10...+50
Max. humidity	ϕ	%	95	95	95	95
Degree of protection	IP	–	54S	54S	54S	54S

¹⁾ Buckling limitation for long strokes, also limited by accessories and configurations. Please check the CASM-100 configuration tool on ewellix.com

²⁾ Maximum dynamic axial force usable to apply the theoretical lifetime calculation (L10)

³⁾ Preferred stroke range:

from 50 to 1 000 mm stroke is by 50 mm step (50, 100, 150, ..., 900, 950, 1 000)

from 1 000 to 2 000 mm stroke is by 100 mm step (1 100, 1 200, ..., 1 900, 2 000, valid for BA, BB and BC screw type excluding RA one)

For all other strokes, out of the preferred range, consider an additional 1 week on standard leadtime. Please contact Ewellix

⁴⁾ Longer strokes are available at longer lead times, please contact Ewellix for more information.

⁵⁾ Permitted average output power < 450 W

Ordering key

See page 19

Dimensional drawing

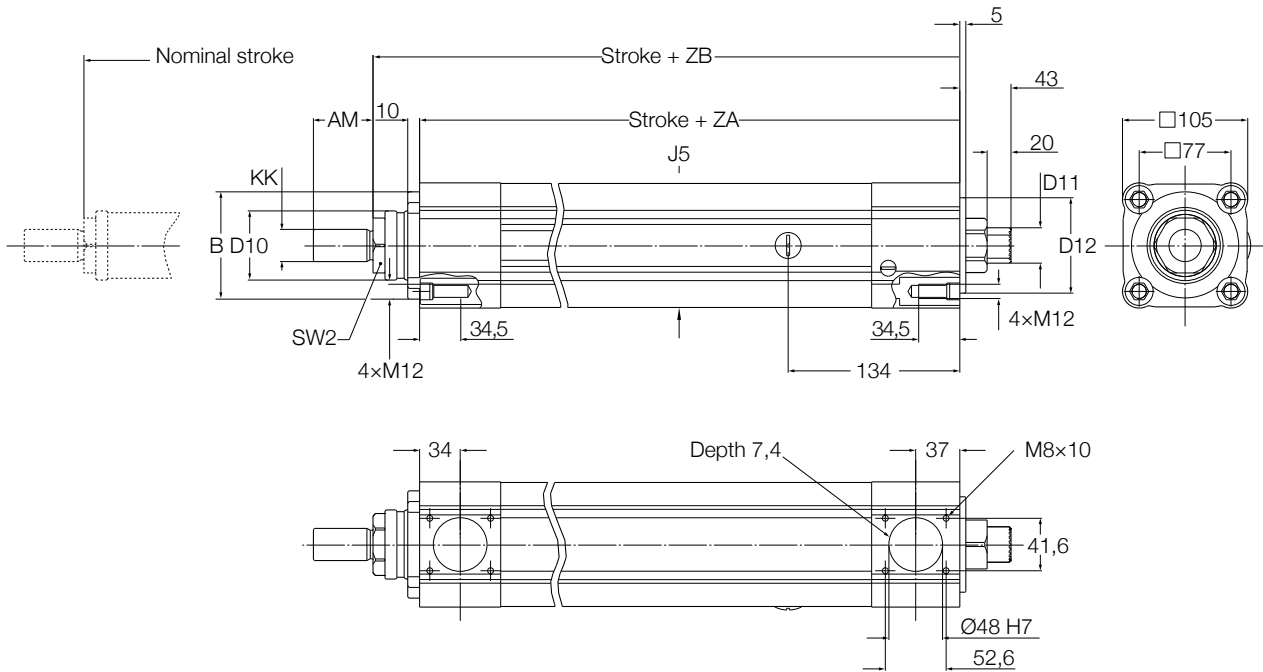

Linear Unit	KK	SW2	J5	ZA	ZB	B	D10	AM	D12	D11
-	-	-	mm							
CASM-100-xx-xxxx-A...	M27 × 2	AF 46	□ 104	287±1,5	326±2	Ø90	^{-0.10} / _{-0.35} Ø58	50	Ø80	^{-0.02} / _{-0.07} Spline DIN 5480 W 30x1,25x22x8f

Performance diagram

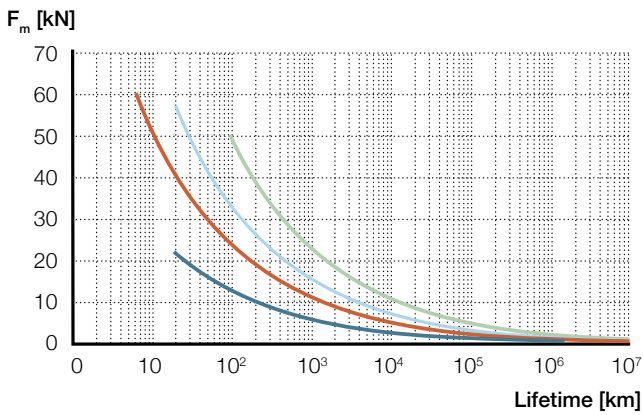

- CASM-100-BA
- CASM-100-BB
- CASM-100-BC
- CASM-100-RA

Buckling load diagram

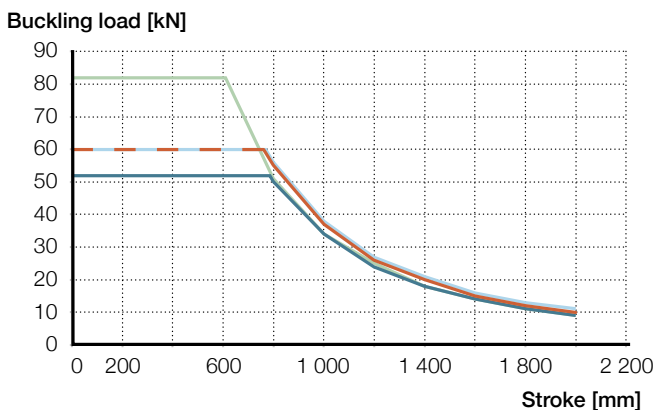

- CASM-100-BA
- CASM-100-BB
- CASM-100-BC
- CASM-100-RA

Options

The following parts are available as options and can be ordered directly through the typekey. It is not necessary (but optional) to order as extra lines if already configured and selected in the typekey.

Front Plate

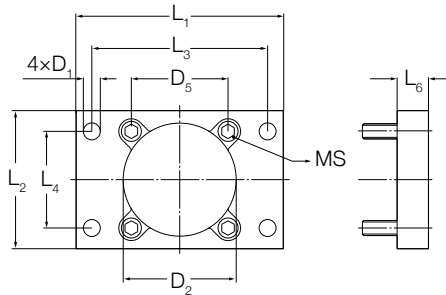

Ordering key
ZBE-377918

Type	MS	L ₁	L ₂	L ₃	L ₄	D ₁	D ₅	D ₂	L ₆	m
-	-	mm								kg
ZBE-377918	M12 × 40	165	109	140	77	Ø13,5	□ 77	Ø90	25	2,1

Foot Mount

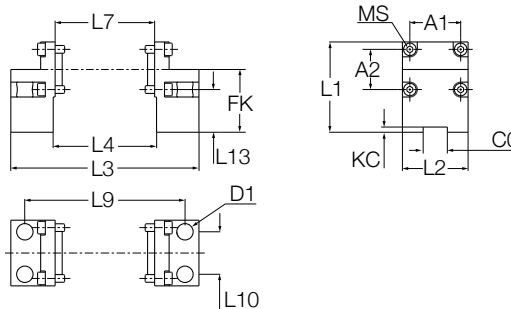

Ordering key
ZBE-377920

Load limit see graph on page 18.

Type	MS	L ₁	L ₂	L ₃	L ₄	L ₇	FK	A ₁	A ₂	L ₉	L ₁₀	KC	C0	L ₁₃	D ₁	m
-	-	mm														kg
ZBE-377920	M8 × 20	93,5	68	194,8	107	103	65	52,6	41,6	165,8	44	5,4	25	44	Ø17	2,8

Pivot Attachment

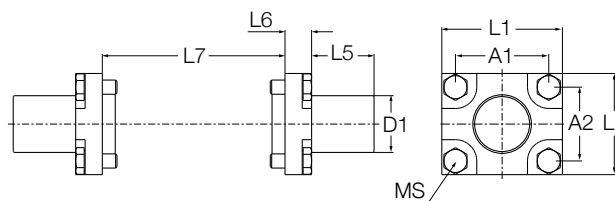
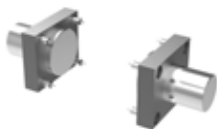

Ordering key
ZBE-377919

Load limit see graph on page 18.

Type	MS	L ₁	L ₂	A ₁	A ₂	L ₅	L ₆	L ₇	D ₁	m
-	-	mm								kg
ZBE-377919	M8 × 18	68	57	52,6	41,6	35,2	15	103	Ø32	1,5

Housing Attachment

Load rating and lifetime limitation of the pivot and foot mount, see graph below.

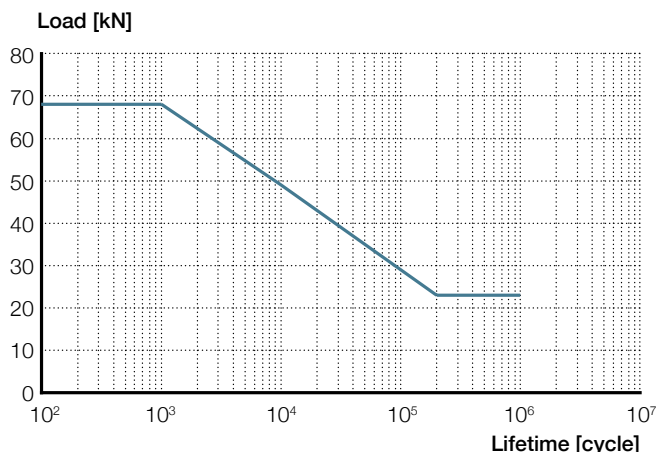

Ingress protection

The linear unit is available with the following ingress protection options (note that IP ratings are valid if the bearing housing is sealed by Ewellix gearbox or others with similar sealing performances):

Option B: IP54S

Protected against dust and water spray if standing still.

Option C: IP65 with sinter filter

Requiring sinter filter to be protected from dust and water. As a consequence it is required to face sinter filter downwards to protect it from rain. If not possible to protect the sinter filter, and to ensure ingress protection level, please take option D (see below).

In addition, and due to the use of solid oil ring and single lip wiper on the front, performances are restricted to avoid premature wear on the sealing. It restricts performances to the following:

Max linear speed	Vmax	35 mm/s
Lifetime distance driven	L	100 km

Option D: IP65 with hose

If selected, a dedicated interface valve is provided and mounted on the linear unit, allowing the actuator to breath. A hose (not provided by Ewellix) need to be connected to this interface valve in order to supply it with clean air.

It still restricts performances as indicated for Option C.

Interface valve

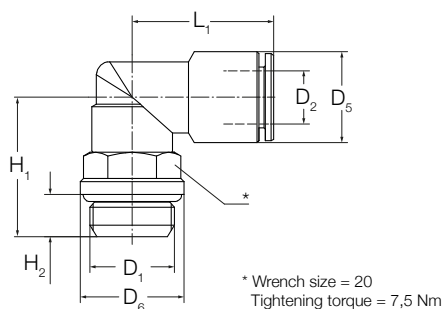

G thread with sealing ring

Connections	Tubing O.D.			H1	H2	L1	Weight/ piece
D1	D2	D5	D6				
-	Ø	Ø	Ø				g
G 1/4	12	19	16	25,5	6,5	28,5	58,5

Ordering key

Linear unit

C A S M - 1 0 0 - B C - 0 1 0 0 - A A 0 C 1 0 A - B A 1 1 0 0 - 0 0 0

Size

Screw type

- BA Ball screw 32 × 10
- BB Ball screw 40 × 10
- BC Ball screw 40 × 20
- RA Roller screw 30 × 10

Stroke

- Stroke in mm

Push tube

- A E355 chrome plated, Ø55

Front housing and attachments

- A Aluminium, no mounting option
- B Aluminium, with body attachment

Front housing attachment

- 0 None
- A Front plate 90° mounting position
- B Front plate 0° mounting position
- C Pivot attachment (trunnion brackets to be ordered separately)
- D Foot mount, 0° mounting position
- E Foot mount, 180° mounting position

Rear housing

- A1 Aluminium, no mounting option, reduced static load, for screw type BA¹⁾
- B1 Aluminium, prepared for pivot or foot mounting, reduced static load, for screw type BA¹⁾
- C1 Aluminium, no mounting option, for all screw types
- D1 Aluminium, prepared for pivot or foot mounting, for all screw types

Rear housing attachment

- 0 None
- C Pivot attachment (trunnion brackets to be ordered separately)
- D Foot mount, 0° mounting position
- E Foot mount, 180° mounting position

Protection tube

- A Aluminium, 90°, recommended for parallel
- B Aluminium, 180°
- C Aluminium, 270°
- D Aluminium, 0°, recommended for inline

¹⁾Maximum static axial force limited to 31 kN, axial play of 0,3 mm.

C A S M - 1 0 0 - B C - 0 1 0 0 - A A 0 C 1 0 A - B A 1 1 0 0 - 0 0 0

Sealing

- B IP54S
- C IP65 with sinter filter
- D IP65 with hose

Lubrication

- A Standard Lubrication for ball screws
- B Standard Lubrication for roller screws

Relubrication

- 0 No relubrication possibility
- 1 With relubrication possibility

Anti-rotation

- 0 No anti-rotation
- 1 With anti-rotation

Free parameter

- 00 Empty

Customer option

- 000 No option

Mounting position front plate and foot mount

The 0° reference for the linear unit is the sinter filter position. The front plate can be turned in 90° steps clockwise. The foot mount can be turned in 180° steps clockwise.

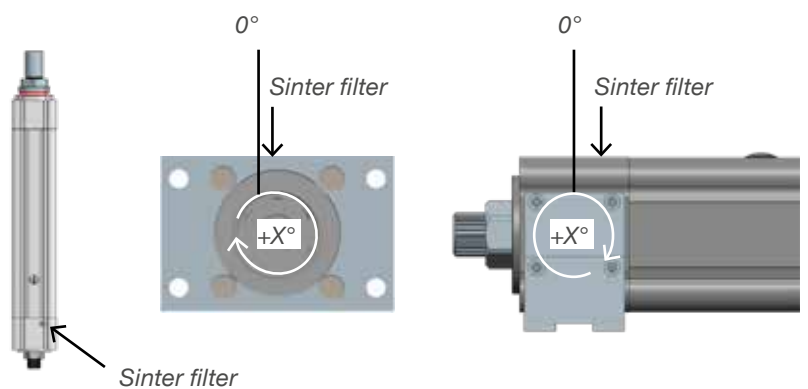

Fig. 5

CASM-100-BA

Electric cylinder servo motor,
inline configuration



Technical data

Designation	Symbol	Unit	1FK7044	1FK7064	1FK7086	1FK7105
Performance Data						
Continuous force @ zero speed	F_{c0}	kN	2,4	6,4	15	23
Continuous force @ max. speed	F_c	kN	2,2	5,9	11,2	21,4
Peak force @ zero speed	F_{p0}	kN	7	17,1	23	23
Peak force @ max. speed	F_p	kN	7	17,1	23	23
Dynamic load capacity	C	kN	27,1	27,1	27,1	27,1
Holding force (motorbrake option)	F_{Hold}	kN	3,5	9,1	16,1	23
Max. linear speed	v_{max}	mm/s	260	260	260	260
Max. acceleration	a_{max}	m/s ²	6	6	6	6
Duty cycle	D	%	100	100	100	100
Mechanical Data						
Screw type	–	–	Ball screw	Ball screw	Ball screw	Ball screw
Screw diameter	d_{screw}	mm	32	32	32	32
Screw lead	p_{screw}	mm	10	10	10	10
Lead accuracy	-	-	G9	G9	G9	G9
Stroke ^{1) 2)}	s	mm	50...2 000	50...2 000	50...2 000	50...2 000
Internal overstroke each side	s0	mm	2	2	2	2
Backlash	$s_{backlash}$	mm	0,2	0,2	0,2	0,2
Gear reduction	i	-	1	1	1	1
Efficiency	η	%	77	79	79	80
Inertia @ 0 mm stroke	J	10 ⁻⁴ kgm ²	6,16	12,4	26,9	159
Δ Inertia per 100 mm	ΔJ	10 ⁻⁴ kgm ²	0,64	0,64	0,64	0,64
Inertia of optional brake	J_{brake}	10 ⁻⁴ kgm ²	0,36	1	3,50	8
Weight @ 0 mm stroke	m	kg	19,8	28,7	37,8	56,4
Δ weight per 100 mm	Δm	kg	2,4	2,4	2,4	2,4
Weight of optional brake	m_{brake}	kg	0,6	1,4	3	4,5
Electrical Data						
Motor type	–	–	Servo	Servo	Servo	Servo
Nominal voltage	U	V DC	600	600	600	600
Nominal current	I	A	3,9	7,6	5,7	18
Peak current	I_{peak}	A	5,4	10,8	21,5	31
Nominal power	P	kW	1,4	2,5	3,75	8,2
Environment & Standards						
Ambient temperature	$T_{ambient}$	°C	-20...+50	-20...+50	-20...+50	-20...+50
Max. humidity	ϕ	%	95	95	95	95
Degree of protection	IP	–	54S	54S	54S	54S

¹⁾ Preferred stroke range:

from 50 to 1 000 mm stroke is by 50 mm step (50, 100, 150, ..., 900, 950, 1 000)

from 1 000 to 2 000 mm stroke is by 100 mm step (1 100, 1 200, ..., 1 900, 2 000)

For all other strokes, out of the preferred range, consider an additional 1 week on standard leadtime. Please contact Ewellix.

²⁾ Longer strokes are available at longer lead times, please contact Ewellix for more information.

Performance diagram

Axial force [N]

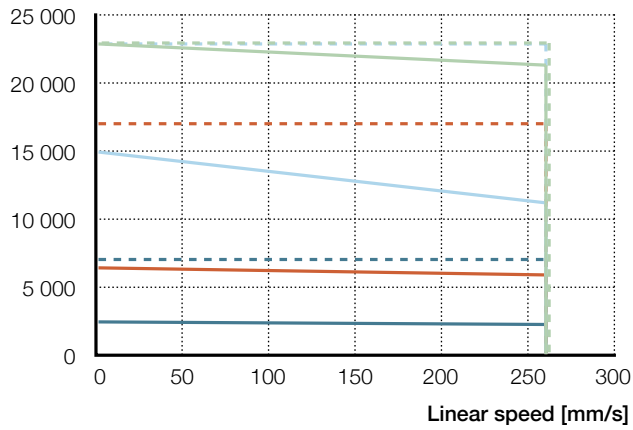

1FK7044 F_{cont} F_{peak}

1FK7064 F_{cont} F_{peak}

1FK7086 F_{cont} F_{peak}

1FK7105 F_{cont} F_{peak}

Dimensional drawing

See page 29

Ordering key

See page 33

CASM-100-BB

Electric cylinder servo motor,
inline configuration



Technical data

Designation	Symbol	Unit	1FK7044	1FK7064	1FK7086	1FK7105
Performance Data						
Continuous force @ zero speed	F_{c0}	kN	2,4	6,4	14,9	25,6
Continuous force @ max. speed	F_c	kN	2,2	6,1	12,8	21,9
Peak force @ zero speed	F_{p0}	kN	6,9	17,1	56	57
Peak force @ max. speed	F_p	kN	6,9	17,1	56	57
Dynamic load capacity	C	kN	71	71	71	71
Holding force (motorbrake option)	F_{Hold}	kN	3,5	9,1	16,1	29,3
Max. linear speed	v_{max}	mm/s	210	210	210	210
Max. acceleration	a_{max}	m/s ²	6	6	6	6
Duty cycle	D	%	100	100	100	100
Mechanical Data						
Screw type	–	–	Ball screw	Ball screw	Ball screw	Ball screw
Screw diameter	d_{screw}	mm	40	40	40	40
Screw lead	p_{screw}	mm	10	10	10	10
Lead accuracy	-	-	G9	G9	G9	G9
Stroke ^{1) 2)}	s	mm	50...2 000	50...2 000	50...2 000	50...2 000
Internal overstroke each side	s0	mm	2	2	2	2
Backlash	$s_{backlash}$	mm	0,2	0,2	0,2	0,2
Gear reduction	i	–	1	1	1	1
Efficiency	η	%	77	79	79	80
Inertia @ 0 mm stroke	J	10 ⁻⁴ kgm ²	7,16	13,4	27,9	160
Δ Inertia per 100 mm	ΔJ	10 ⁻⁴ kgm ²	1,44	1,44	1,44	1,44
Inertia of optional brake	J_{brake}	10 ⁻⁴ kgm ²	0,36	1	3,5	8
Weight @ 0 mm stroke	m	kg	21,5	30,4	39,5	58,1
Δ weight per 100 mm	Δm	kg	2,7	2,7	2,7	2,7
Weight of optional brake	m_{brake}	kg	0,6	1,4	3	4,5
Electrical Data						
Motor type	–	–	Servo	Servo	Servo	Servo
Nominal voltage	U	V DC	600	600	600	600
Nominal current	I	A	3,9	7,6	5,7	18
Peak current	I_{peak}	A	5,4	10,8	21,5	31
Nominal power	P	kW	1,4	2,5	3,75	8,2
Environment & Standards						
Ambient temperature	$T_{ambient}$	°C	-20...+50	-20...+50	-20...+50	-20...+50
Max. humidity	ϕ	%	95	95	95	95
Degree of protection	IP	–	54S	54S	54S	54S

¹⁾ Preferred stroke range:

from 50 to 1 000 mm stroke is by 50 mm step (50, 100, 150, ..., 900, 950, 1 000)

from 1 000 to 2 000 mm stroke is by 100 mm step (1 100, 1 200, ..., 1 900, 2 000)

For all other strokes, out of the preferred range, consider an additional 1 week on standard leadtime. Please contact Ewellix.

²⁾ Longer strokes are available at longer lead times, please contact Ewellix for more information.

Performance diagram

Axial force [N]

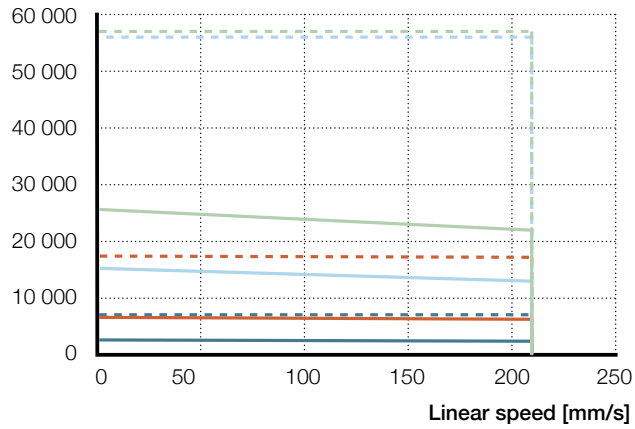

1FK7044 F_{cont} F_{peak}

1FK7064 F_{cont} F_{peak}

1FK7086 F_{cont} F_{peak}

1FK7105 F_{cont} F_{peak}

Dimensional drawing

See page 29

Ordering key

See page 33

CASM-100-BC

Electric cylinder servo motor,
inline configuration



Technical data

Designation	Symbol	Unit	1FK7044	1FK7064	1FK7086	1FK7105
Performance Data						
Continuous force @ zero speed	F_{c0}	kN	1,2	3,2	7,5	12,8
Continuous force @ max. speed	F_c	kN	1,1	2,5	4	9,3
Peak force @ zero speed	F_{p0}	kN	3,5	8,5	28	40
Peak force @ max. speed	F_p	kN	3,5	8	26,7	40
Dynamic load capacity	C	kN	41,3	41,3	41,3	41,3
Holding force (motorbrake option)	F_{Hold}	kN	1,7	4,5	8	14,7
Max. linear speed	v_{max}	mm/s	750	750	750	750
Max. acceleration	a_{max}	m/s ²	12	12	12	12
Duty cycle	D	%	100	100	100	100
Mechanical Data						
Screw type	–	–	Ball screw	Ball screw	Ball screw	Ball screw
Screw diameter	d_{screw}	mm	40	40	40	40
Screw lead	p_{screw}	mm	20	20	20	20
Lead accuracy	-	-	G9	G9	G9	G9
Stroke ^{1) 2)}	s	mm	50...2 000	50...2 000	50...2 000	50...2 000
Internal overstroke each side	s0	mm	2	2	2	2
Backlash	$s_{backlash}$	mm	0,2	0,2	0,2	0,2
Gear reduction	i	-	1	1	1	1
Efficiency	η	%	77	79	79	80
Inertia @ 0 mm stroke	J	10 ⁻⁴ kgm ²	7,16	13,4	27,9	160
Δ Inertia per 100 mm	ΔJ	10 ⁻⁴ kgm ²	1,38	1,38	1,38	1,38
Inertia of optional brake	J_{brake}	10 ⁻⁴ kgm ²	0,36	1	3,5	8
Weight @ 0 mm stroke	m	kg	21,1	30	39,1	57,7
Δ weight per 100 mm	Δm	kg	2,7	2,7	2,7	2,7
Weight of optional brake	m_{brake}	kg	0,6	1,4	3	4,5
Electrical Data						
Motor type	–	–	Servo	Servo	Servo	Servo
Nominal voltage	U	V DC	600	600	600	600
Nominal current	I	A	3,9	7,6	5,7	18
Peak current	I_{peak}	A	5,4	10,8	21,5	31
Nominal power	P	kW	1,4	2,5	3,75	8,2
Environment & Standards						
Ambient temperature	$T_{ambient}$	°C	-20...+50	-20...+50	-20...+50	-20...+50
Max. humidity	ϕ	%	95	95	95	95
Degree of protection	IP	–	54S	54S	54S	54S

¹⁾ Preferred stroke range:

from 50 to 1 000 mm stroke is by 50 mm step (50, 100, 150, ..., 900, 950, 1 000)

from 1 000 to 2 000 mm stroke is by 100 mm step (1 100, 1 200, ..., 1 900, 2 000)

For all other strokes, out of the preferred range, consider an additional 1 week on standard leadtime. Please contact Ewellix.

²⁾ Longer strokes are available at longer lead times, please contact Ewellix for more information.

Performance diagram

Axial force [N]

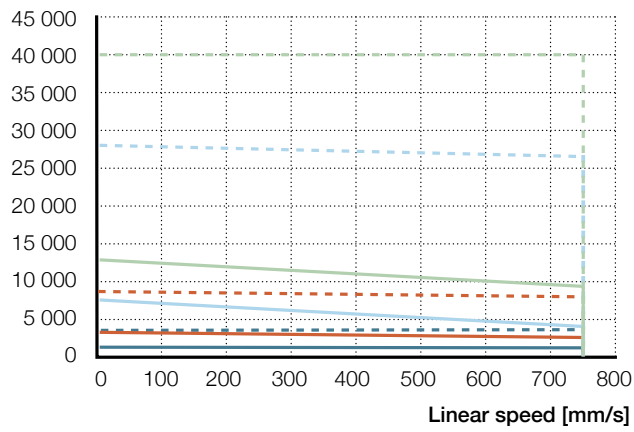

1FK7044 — F_{cont} — F_{peak}

1FK7064 — F_{cont} — F_{peak}

1FK7086 — F_{cont} — F_{peak}

1FK7105 — F_{cont} — F_{peak}

Dimensional drawing

See page 29

Ordering key

See page 33

CASM-100-RA

Electric cylinder servo motor,
inline configuration



Technical data

Designation	Symbol	Unit	1FK7044	1FK7064	1FK7086	1FK7105
Performance Data						
Continuous force @ zero speed	F_{c0}	kN	2,3	6	14,1	24,1
Continuous force @ max. speed	F_c	kN	1,5	4	3,5	13,1
Peak force @ zero speed	F_{p0}	kN	6,5	16,1	52,8	75,5
Peak force @ max. speed	F_p	kN	6,3	11,6	39,2	75
Dynamic load capacity	C	kN	106	106	106	106
Holding force (motorbrake option)	F_{Hold}	kN	3,7	9,6	17	31
Max. linear speed	v_{max}	mm/s	750	500	500	500
Max. acceleration	a_{max}	m/s ²	12	12	12	12
Duty cycle	D	%	100	100	100	100
Mechanical Data						
Screw type	–	–	Roller screw	Roller screw	Roller screw	Roller screw
Screw diameter	d_{screw}	mm	30	30	30	30
Screw lead	p_{screw}	mm	10	10	10	10
Lead accuracy	–	–	G5	G5	G5	G5
Stroke ^{1) 2)}	s	mm	50...1 000	50...1 000	50...1 000	50...1 000
Internal overstroke each side	s0	mm	2	2	2	2
Backlash	$s_{backlash}$	mm	0,2	0,2	0,2	0,2
Gear reduction	i	–	1	1	1	1
Efficiency	η	%	73	74	74	75
Inertia @ 0 mm stroke	J	10 ⁻⁴ kgm ²	6,56	12,8	27,3	159
Δ Inertia per 100 mm	ΔJ	10 ⁻⁴ kgm ²	0,63	0,63	0,63	0,63
Inertia of optional brake	J_{brake}	10 ⁻⁴ kgm ²	0,36	1	3,5	8
Weight @ 0 mm stroke	m	kg	21,3	30,2	39,3	57,9
Δ weight per 100 mm	Δm	kg	2,4	2,4	2,4	2,4
Weight of optional brake	m_{brake}	kg	0,6	1,4	3	4,5
Electrical Data						
Motor type	–	–	Servo	Servo	Servo	Servo
Nominal voltage	U	V DC	600	600	600	600
Nominal current	I	A	3,9	7,6	5,7	18
Peak current	I_{peak}	A	5,4	10,8	21,5	31
Nominal power	P	kW	1,4	2,5	3,75	8,2
Environment & Standards						
Ambient temperature	$T_{ambient}$	°C	-10...+50	-10...+50	-10...+50	-10...+50
Max. humidity	ϕ	%	95	95	95	95
Degree of protection	IP	–	54S	54S	54S	54S

¹⁾ Preferred stroke range:
from 50 to 1 000 mm stroke is by 50 mm step (50, 100, 150, ..., 900, 950, 1 000)
For all other strokes, out of the preferred range, consider an additional 1 week on standard leadtime. Please contact Ewellix.
²⁾ Longer strokes are available at longer lead times, please contact Ewellix for more information.

Performance diagram

Axial force [N]

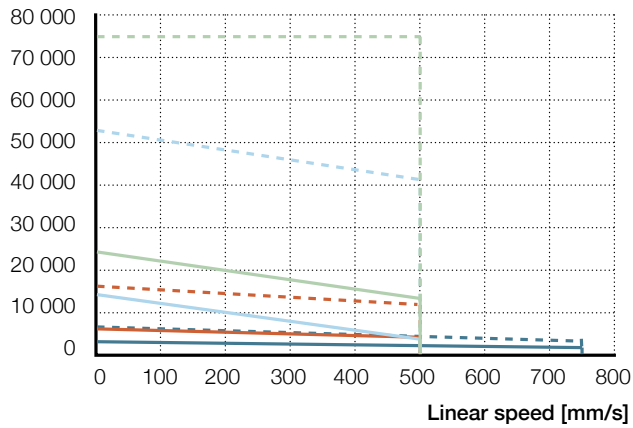

1FK7044 — F_{cont} — F_{peak}

1FK7064 — F_{cont} — F_{peak}

1FK7086 — F_{cont} — F_{peak}

1FK7105 — F_{cont} — F_{peak}

Dimensional drawing

See page 29

Ordering key

See page 33

Dimensional drawing

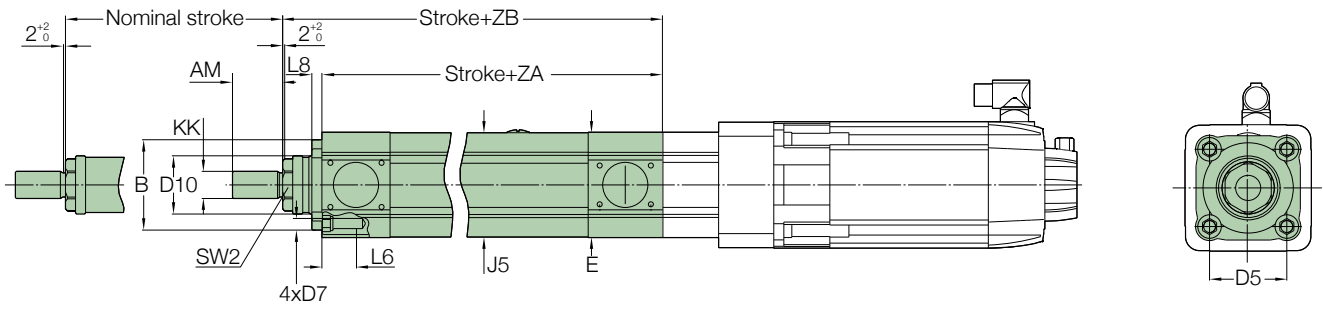

Linear Unit	KK	SW 2	D7	J5	E	ZA	ZB	L8	B	D10	AM	D5	L6
-	-	-	-	mm									
CASM-100-xx-xxxx-A...	M27 x 2 AF 46	M12	□ 104	□ 105	287±1,5	326±2	10	Ø90	^{-0,10} / _{-0,35}	Ø58	50	□ 77	34,5

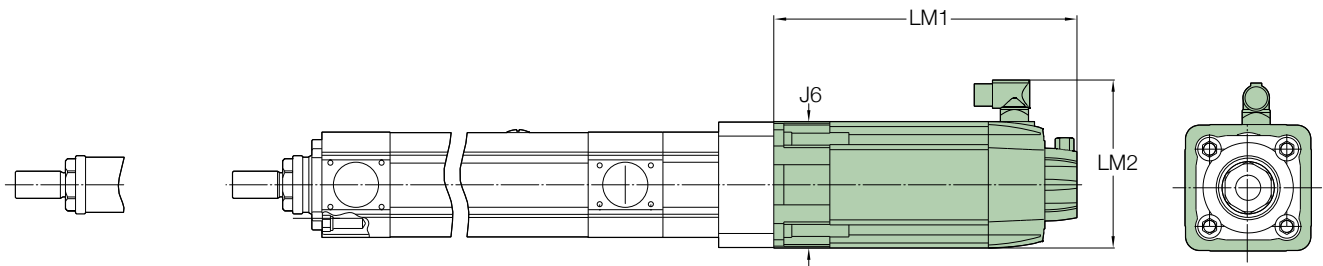

Motor	LM1	LM2	J6
-	mm		
CAM-MS-xO-A11-000	242,5	139,5	□ 96
CAM-MS-xO-A12-000	302,5	167,5	□ 126
CAM-MS-xO-A13-000	309,5	216,5	□ 155
CAM-MS-xO-A14-000	340	253	□ 192

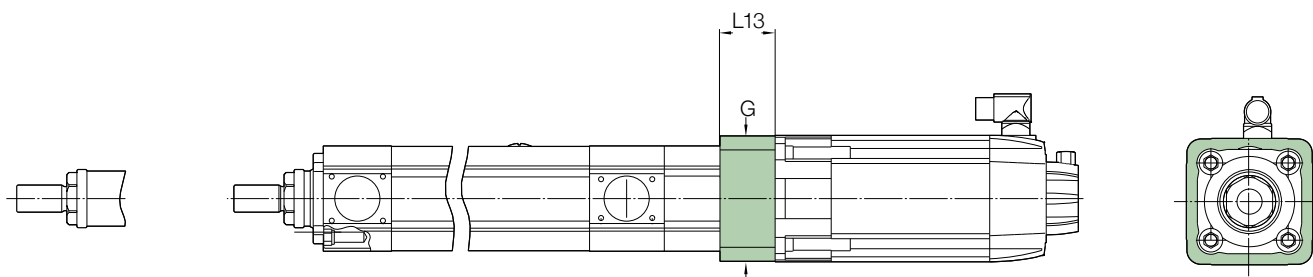

Motor adapter	G	L13
-	mm	
CAM-MS-xO-A11-000	□ 105	44,5
CAM-MS-xO-A12-000	□ 125	54,5
CAM-MS-xO-A13-000	□ 139	62,5
CAM-MS-xO-A14-000	□ 192,5	85,5

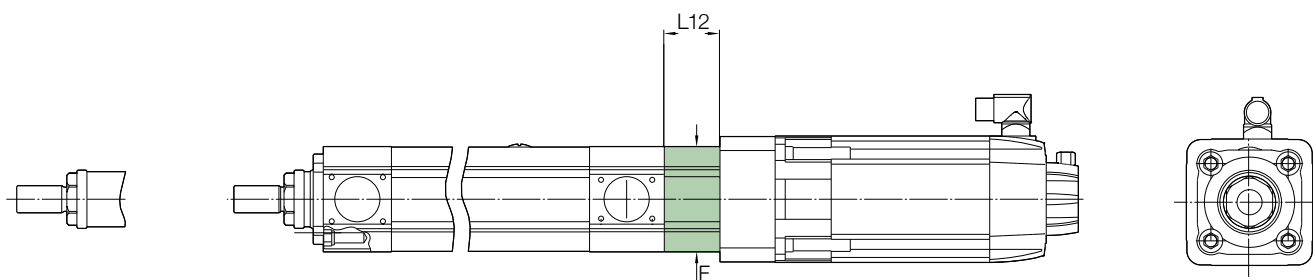

Gearbox	i	F	L12
-	-	mm	
CAM-GI-AAA-00-000	01:01	□ 105	55,5

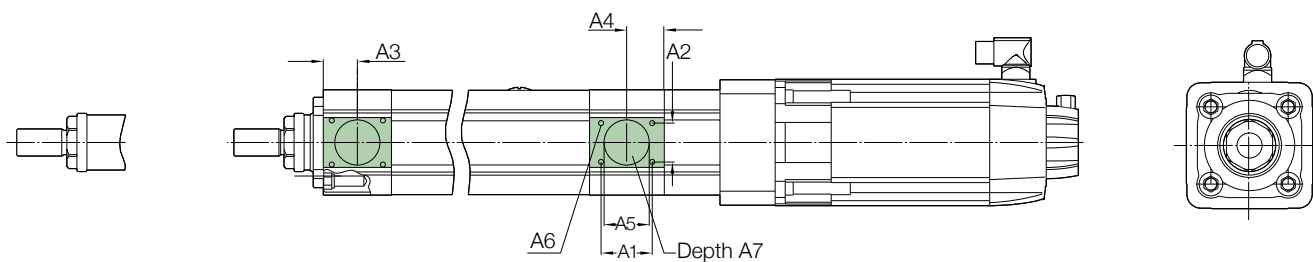

Optional Mounting Possibility	A6	A1	A2	A3	A4	A5	A7
-	-	mm					
CASM-100-xx-xxxx-...	M8 x 10	52,6	41,6	34	37	Ø48 H7	7,4

Mounting positions

For a complete actuator assembly, the gearbox is used as the 0° reference for all connected modules (↳ fig. 6).

Fig. 6

Gearbox reference

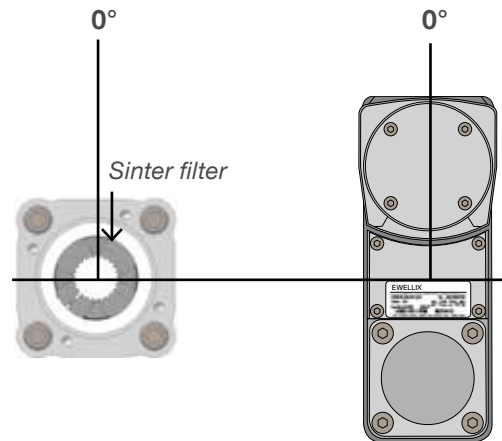

Mounting position protection tube

The 0° reference for the protection tube is the sinter filter position. The protection tube can be turned in 90° steps clockwise (↳ fig. 7). Parallel gearbox mounting positions have some limitations: protection tube with relubrication port can be mounted at 90° - 180° - 270° (0° is not possible) (↳ fig. 8).

Fig. 7

Linear unit reference

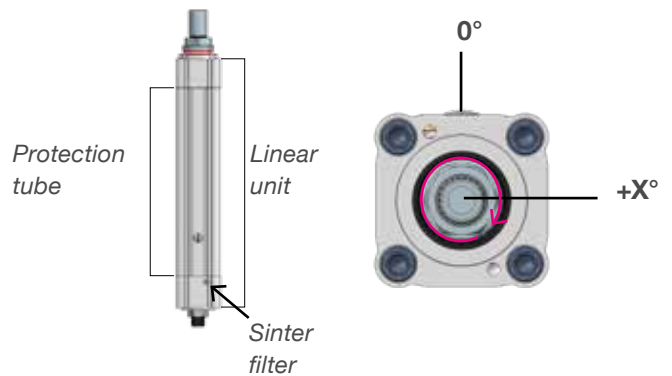

Orientation recommendation

For parallel version, recommended linear unit mounting position is 0° and protection tube mounting position is 90° (270° also possible).

Fig. 8

Linear unit orientation

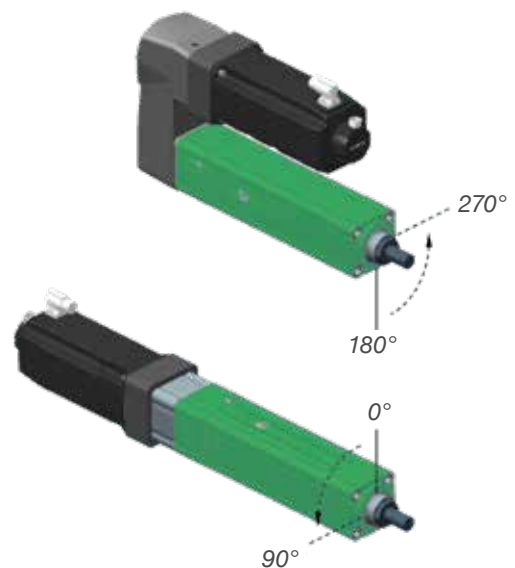

Mounting positions motor

The 0° reference for the motor is the electric connector outlet position. The motor can be turned in 90° steps clockwise (→ **fig. 9**). Parallel gearbox mounting position have some limitations: Motor from sizes Servo 8x / IEC AC 80 and bigger can be mounted at 0° - 90° - 270° (180° is not possible) (→ **fig. 10**).

Fig. 9

Reference motor adapter

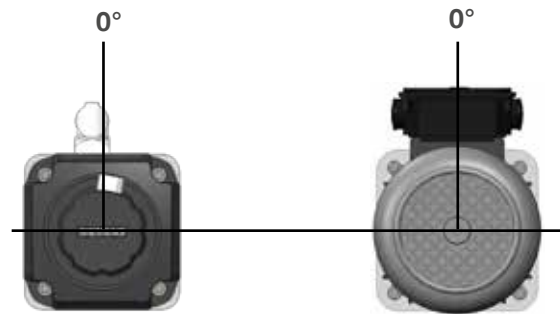
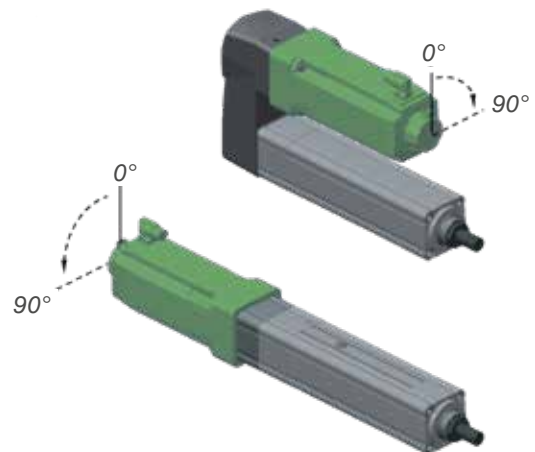
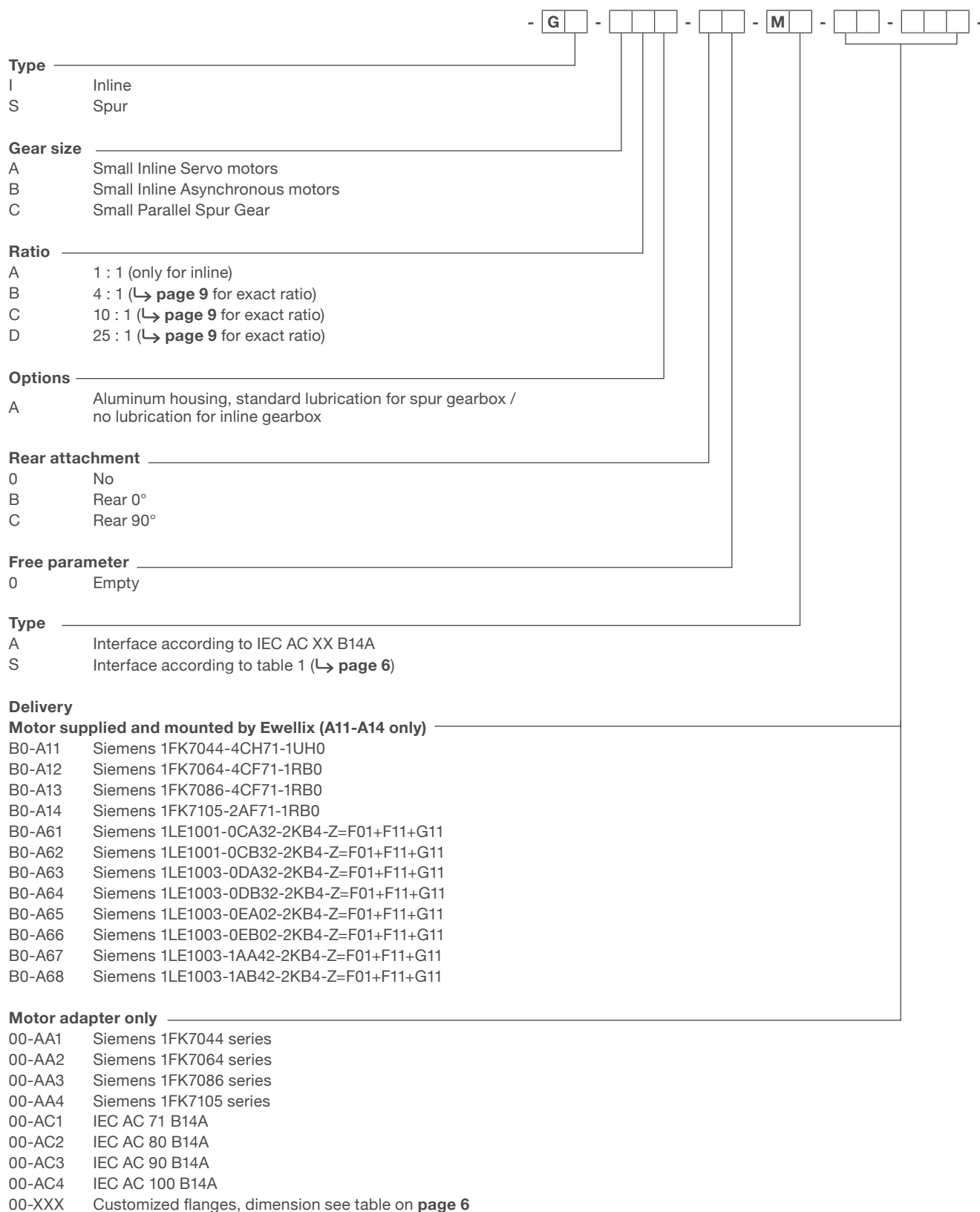

Fig. 10

Motor adapter orientation







Mounting position linear unit

- A 0°, recommended for parallel (standard if no gearbox is selected)
- B 90°
- C 180°
- D 270°

Mounting position motor

- 0 no motor kit selected
- A 0°
- B 90°
- C 180° (Inline Gearbox only)
- D 270°

Customer option

- 000 No option

Fig. 5

Mounting position front plate and foot mount

The 0° reference for the linear unit is the sinter filter position. The front plate can be turned in 90° steps clockwise. The foot mount can be turned in 180° steps clockwise.

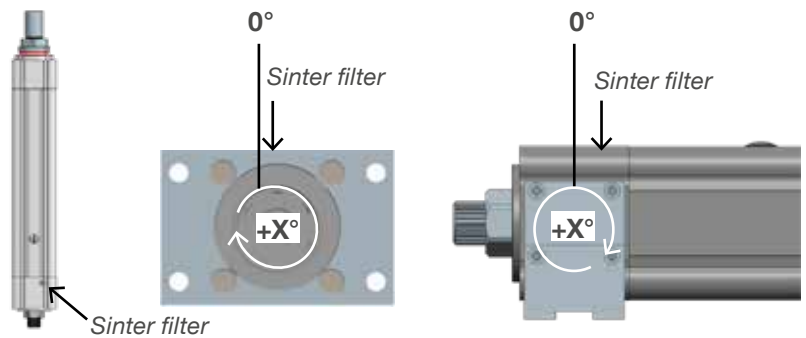

Accessories

CASM-100

Push tube attachments

Rod End

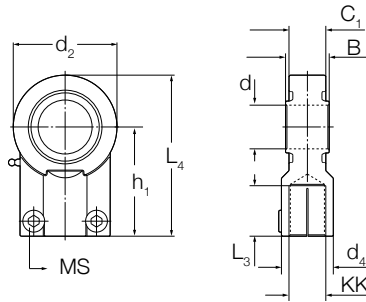

Technical info
 Dynamic load rating: C=65,6 kN
 Static load rating: C=100 kN

Ordering key
 Rod End Ø32:
 ZBE-377900
 (According to
 DIN8132 standard)

Type	KK	MS	L ₃ mm	B	C ₁	d	d ₄	L ₄	h ₁	d ₂	m ₂ kg
ZBE-377900	M27 × 2	M10	37	32	28	Ø32	Ø40	119	80	76	1,2

Rod Clevis

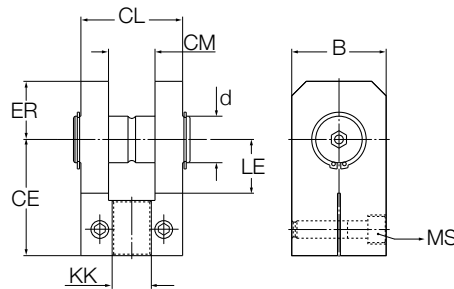

Technical info
 Nominal force:
 50 kN

Ordering key
 Rod Clevis Ø32:
 ZBE-377917
 (According to
 DIN8132 standard)

Type	KK	MS	CL mm	CM	LE	CE	ER	d	B	m kg
ZBE-377917	M27 × 2	M12	70	32	42	80	40	Ø32	65	2,7

Trunnion Bracket Centric

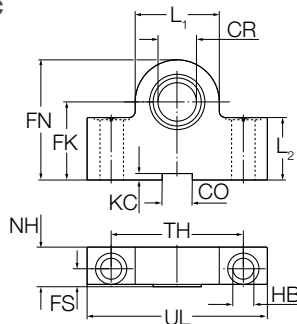

Technical info
 Nominal force:
 50 kN

Ordering key
 Trunnion Bracket
 Centric Ø32:
 ZBE-377902
 (According to
 ISO8132 standard)

Type	CR mm	FN	FK	HB	NH	TH	UL	CO	KC	FS	L ₁	L ₂	m kg
ZBE-377902	Ø32	100	65	Ø17,5	33	110	150	25	5,4	15	70	52	4,7

Trunnion Bracket Eccentric

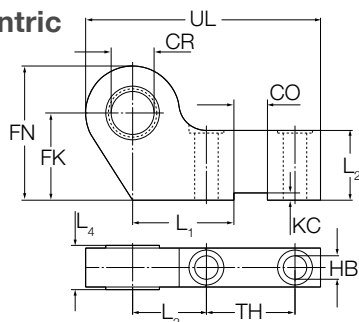

Technical info
Nominal force:
50 kN

Ordering key
ZBE-377910

Type	CR mm	FN	FK	TH	HB	L ₃	UL	CO	KC	L ₄	L ₂	L ₁	m kg
-	mm												
ZBE-377910	Ø32	100	65	66	Ø17,5	55	175	25	5,4	33	52	75,5	4,2

Proximity Switch

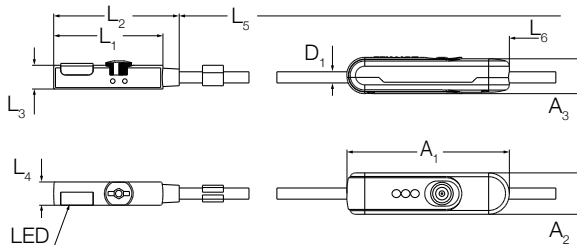

Ordering key
ZSC-377925

Type	L ₁ mm	L ₂	L ₃	L ₄	L ₅	D ₁	A ₁	A ₂	A ₃	L ₆	m kg
-	mm										
ZSC-377925	23,5	27	5,5	5	2 000	Ø2,4	35	8,9	7,9	1 765	0,016

Please refer to Balluff datasheet BMF 235K H-PO-C-A2-PU-02 for detailed technical information.



ewellix.com

© Ewellix

All contents of this publication are the property of Ewellix, and may not be reproduced or given to third parties (even extracts) without permission. Although great care has been taken in the production of this catalog, Ewellix does not take any responsibility for damage or other loss resulting from omissions or typographical errors. The photo may differ slightly in appearance from the actual product. Due to continuous improvements being made in our products, the product's appearance and specifications are subject to change without notice.

PUB IL-07016/4-EN-March 2022