

Electric cylinders CASM-100



High modularity



Long strokes



Parallel spur gearbox



Ball and roller
screw technology

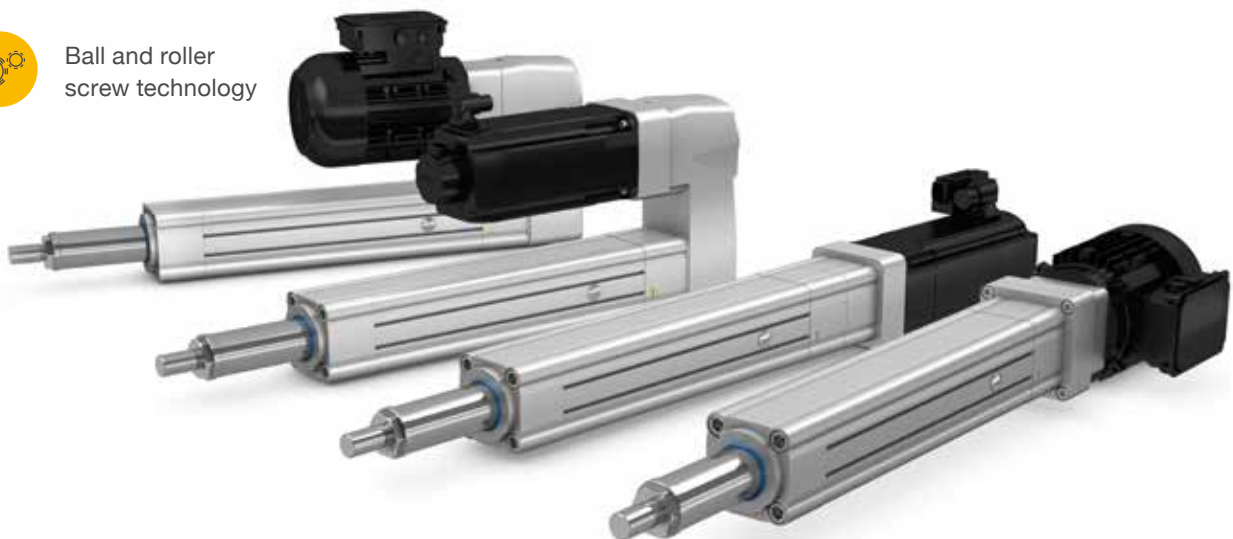

Electric cylinders CASM-100

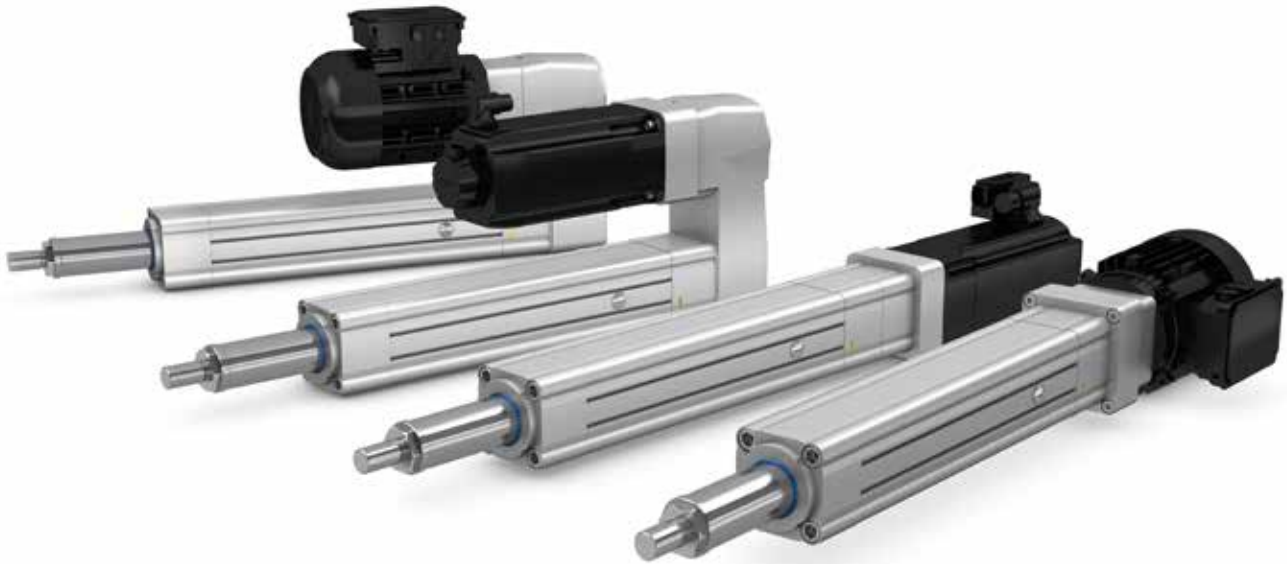

Features

- Electric cylinder with high modularity
- Ball-screws or roller-screws
- Inline and parallel gearboxes
- Standardized interfaces
- High level of precision and repeatability
- Wide range of accessories

Benefits

- For a wide range of applications with different power and lifetime requirements
- Optimal lifetime even at very high forces
- Mechanically fits most of the applications
- Fits AC motors and servo motors
- Accurate positioning (depends on the feedback system of the motor)
- High level of flexibility in mounting the cylinders

Product description

Ewellix developed an innovative modular electric cylinder platform to address most of the applications in the automation and heavy machinery industries, mainly replacing hydraulic solutions. In this new design, instead of limiting the selection on the “linear unit - gearbox – motor” modules only, Ewellix takes it a step further. The modularity has been extended to the base component level. Within each module, the customer can select the components inside to build a custom-like solution as standard. This concept makes it possible to find the optimal solution for almost every application within its power range with the best performance/cost ratio.

To facilitate customers in defining their own actuator, Ewellix has released an online configurator on SKF.com, where you can configure your optimal CASM-100 cylinder in just a few

steps. Since the cylinders are assembled with standard components, any customer defined configuration will not influence the lead time.

To meet any space and performance requirements, Ewellix provides inline and parallel gearboxes as well as AC and servo motors. All motors are equipped with specific adapters to keep the same mechanical interface, independent of the selected motor type.

This standardized interface allows customers to also attach their own preferred motor. This possibility shortens the commissioning of the application, since customers are already familiar with their specific motor and drives.

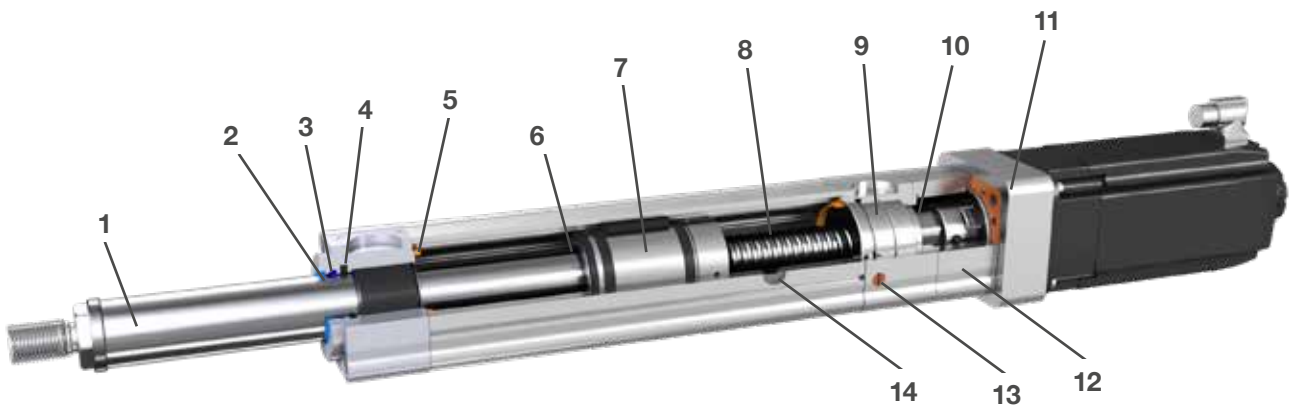

1. Push tube
2. Wiper ring
3. Solid oil ring
4. Sealing ring
5. Rubber bumper
6. Magnet ring for optional proximity sensors
7. Nut with guiding rings and anti-rotation
8. High quality ball and roller screws with low axial play and low friction
9. High quality bearings
10. Radial shaft sealing ring
11. Motor adapter and motor
12. Gearbox
13. Sinter filter for high airflow
14. Relubrication port

System overview

The CASM-100 modular system comprises different components that are connected to each other through standardized interfaces.

Each component provides a unique function for the complete system and is connected as shown below.

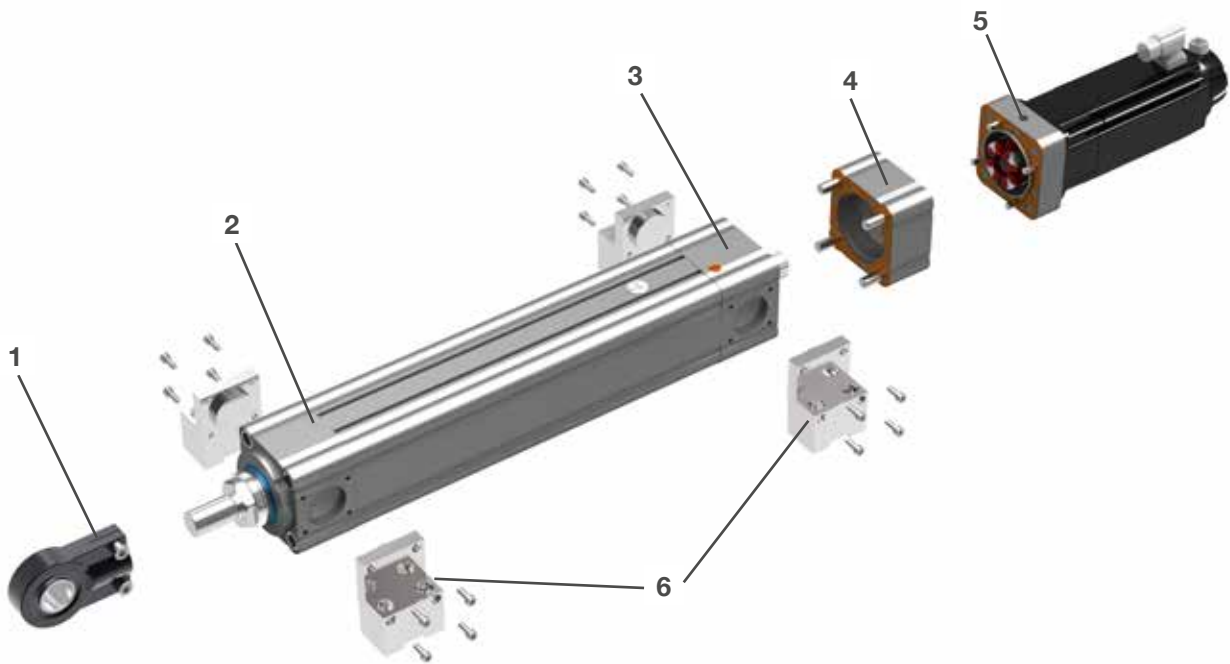

1. Front attachment: mechanical connection between the actuator tube and the moving part of the application. It is screwed to the push tube through the standard male thread.
2. Front housing: component that supports the push tube, through a dedicated bushing, also including the front sealing package
3. Bearing housing: component that contains the set of ball bearings that support the screw shaft
4. Gearbox: connecting module between the linear unit and the motor adapter. Is available in parallel or inline versions, with different reduction ratios
5. Motor adapter: connecting module between the gearbox and the electric motor
6. Housing attachments: actuator body attachments, connected to the fix part of the application. Depending on the attachment type, they can be installed on the different housings - front, bearing or gearbox.

Performance overview of linear units

Linear unit	F _{max} kN	F _{0max}	V _{max} mm/s
CASM-100-BA	23	52	260
CASM-100-BB	48	60	210
CASM-100-BC	60	60	750
CASM-100-RA	82	82	890

Performance overview of actuators

Linear unit	Motor	Adapter	Fc0 kN	Fp0	Vmax mm/s
	-				
CASM-100-BA	1FK7044	inline	2,4	7,0	260
CASM-100-BA	1FK7064	inline	6,4	17,1	260
CASM-100-BA	1FK7086	inline	15	23,0	260
CASM-100-BA	1FK7105	inline	23,0	23,0	260
CASM-100-BB	1FK7044	inline	2,4	6,9	210
CASM-100-BB	1FK7064	inline	6,4	17,1	210
CASM-100-BB	1FK7086	inline	14,9	48,0	210
CASM-100-BB	1FK7105	inline	25,6	48,0	210
CASM-100-BC	1FK7044	inline	1,2	3,5	750
CASM-100-BC	1FK7064	inline	3,2	8,5	750
CASM-100-BC	1FK7086	inline	7,5	28,0	750
CASM-100-BC	1FK7105	inline	12,8	40,0	750
CASM-100-RA	1FK7044	inline	2,3	6,5	750
CASM-100-RA	1FK7064	inline	6,0	16,1	500
CASM-100-RA	1FK7086	inline	14,1	52,8	500
CASM-100-RA	1FK7105	inline	24,1	75,5	500

Motors

Servo motors

The Siemens motors provided by Ewellix come with a differential resolver or multi-turn encoder, a shaft-end with key-way and a holding brake. In addition, they are equipped with a Drive-CLiQ interface. A rotating plug adapter simplifies the connection and cable routing in all installation positions. For more information, please visit the following sites:



Motor:

www.siemens.com/motors

Frequency converters:

www.siemens.com/sinamics

Automation systems:

www.siemens.com/simotion

Controls:

www.siemens.com/simatic

Engineering software:

www.siemens.com/sizer

Support worldwide:

www.siemens.de/service

Motor technical data

Motor type		1FK7044-4CH71-1UH0	1FK7064-4CF71-1RB0	1FK7086-4CF71-1RB0	1FK7105-2AF71-1RB0
Designation	Unit				
Rated power (100K)	kW	1,4	2,5	3,75	8,2
Rated speed	min ⁻¹	4 500	3 000	2 000*	3 000
Rated current	A	3,9	7,6	5,7	18
Rated torque (100K)	Nm	3	8	6,5	26
Static torque (100K)	Nm	4,5	12	28	48
Peak torque	Nm	13	32	105	150
Inertia with brake	10 ⁻⁴ kgm ²	1,62	8,5	25,5	162
Weight with brake	kg	8	16,8	26	43,5

* Maximum speed is 3 000 with lower torque

Motor adapter

The modular system of CASM-100 enables the use of virtually any kind of motor.

The motor adapter module makes your motor fit the entire CASM-100 range, independent of the configuration. In fact, thanks to the standardized mechanical interface, this module can be directly attached to any inline or parallel gearbox. Sealings, screws and half coupling parts are included in the package. Each motor adapter is provided with blind threaded hole M12 to screw an eye bolt for easier actuator handling.

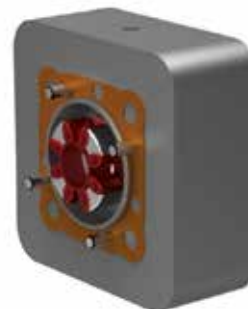

Dimensional drawing

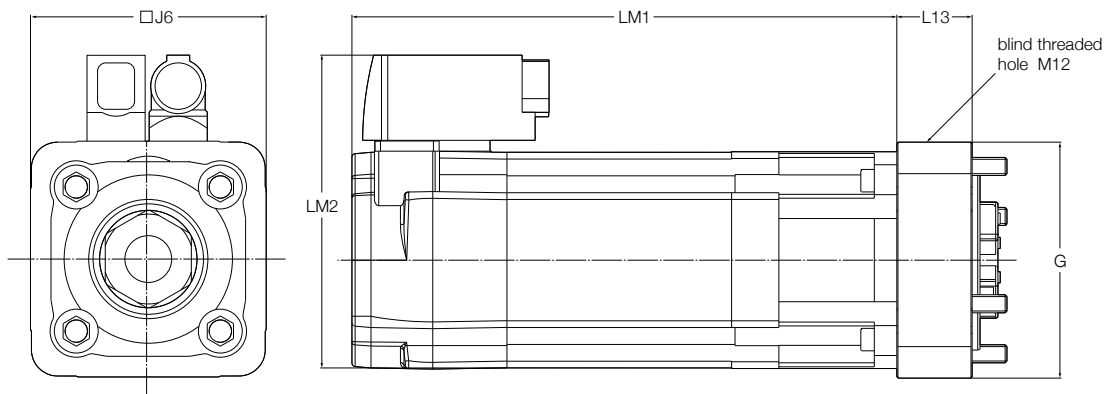

	Motor LM1 mm	LM2	J6	Motor adapter G	L13
-					
CAM-MS-B0-A11	242,5	139,5	□ 96	□ 105	33,5
CAM-MS-B0-A12	302,5	167,5	□ 126	□ 125	55,5
CAM-MS-B0-A13	309,5	216,5	□ 155	□ 155	63,5
CAM-MS-B0-A14	340	253	□ 192	□ 192,5	85,5

Third party motors

In order to attach your preferred motor to the gearbox, Ewelix offers tailor made solutions within the specifications below. For motor specifications which are not covered by the specifications below, please contact Ewelix.

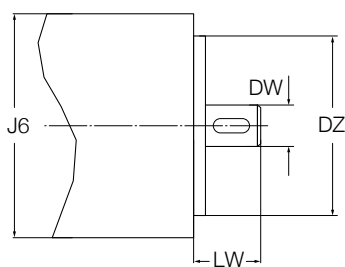

	min mm	max
-		
LW	15	unlimited
DW	12	42
DZ	>57	unlimited
J6	>DZ	255*

* Limitation valid only with the parallel gearbox CAM-GS

Ordering key

Servo motor

C A S M - M S - 0 0 - A 1 1 - 0 0 0

Motor option

- O Delivery without motor
- B Motor supplied and mounted by SKF

Motor Type

- A11 Siemens 1FK7044-4CH71-1UH0
- A12 Siemens 1FK7064-4CF71-1RB0
- A13 Siemens 1FK7086-4CF71-1RB0
- A14 Siemens 1FK7105-2AF71-1RB0

Gearboxes

Inline gearbox

Inline gearboxes consist of a housing which fits on one side to the linear unit and on the other side to the motor adapter with the matching coupling. The coupling can be pushed on the shaft of the linear unit and locked by a screw. The counterpart of the coupling is delivered with the motor adapter. The inline gearbox transmits the motor torque (max. 150 Nm) directly to the linear unit with a gear ratio 1:1 and is maintenance-free.



Dimensional drawing

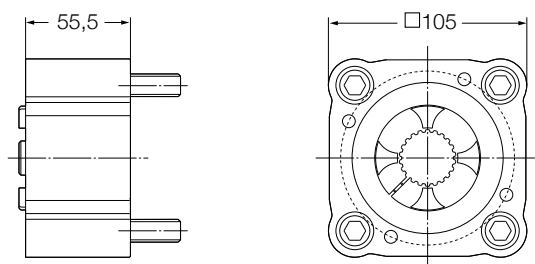

All dimensions in mm

Complete actuator

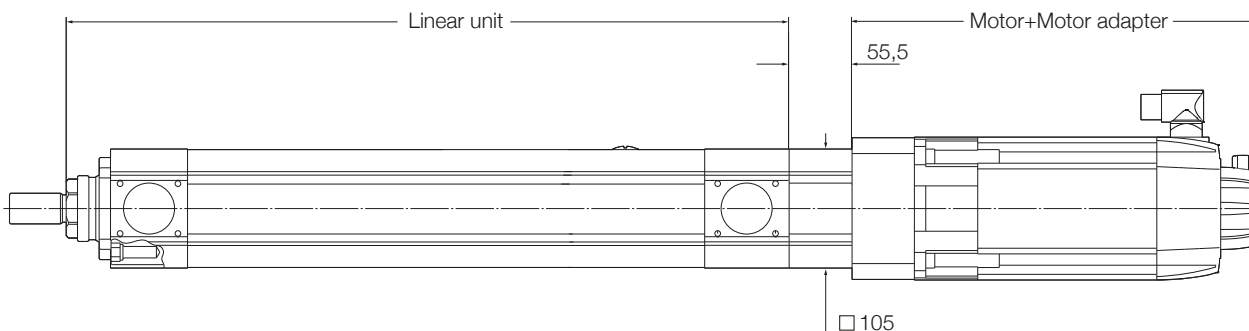

All dimensions in mm

Parallel gearbox

Parallel gearbox consists of one housing which fits on one side to the linear unit and on the other side to the motor adapter with the matching coupling. The coupling is already mounted on the input shaft of the gearbox and locked by a screw. The counterpart of the coupling is delivered with the motor adapter.

The parallel gearbox transmits the motor torque through three stage spur gear directly to the linear unit (max. output torque 300 Nm). Three gear ratios are available and it is maintenance free.



Technical data

Gearbox type		CAM-GS-CBA-XX	CAM-GS-CCA-XX	CAM-GS-CDA-XX
Short designation	Unit			
Type	–	Parallel	Parallel	Parallel
Gear reduction	–	3,89	9,82	24,95
Nominal output torque	Nm	100	100	100
Max. output torque	Nm	300	300	300
Max. input power	W	3 000	3 000	3 000
Max. input speed	r/min	4 500	4 500	4 500
Efficiency	%	85	85	85
Duty cycle ¹⁾	%	100	100	100
Weight	kg	9	9	9
Length	mm	98,5	98,5	98,5

¹⁾Can be limited by temperature, power and force combination

Manual override

The parallel gearbox has a manual override as built-in functionality. The gearbox can be manually operated through a hexagonal key located on the gearbox motor axis. As standard, the access to this key is covered by a plate (↳ **fig. 1**). On request, it's possible to have a round opening for direct access (↳ **fig. 2**) or to mount an electromagnetic brake (↳ **fig. 3**).

Fig. 1



Fig. 2



On request

Fig. 3



On request

Dimensional drawing

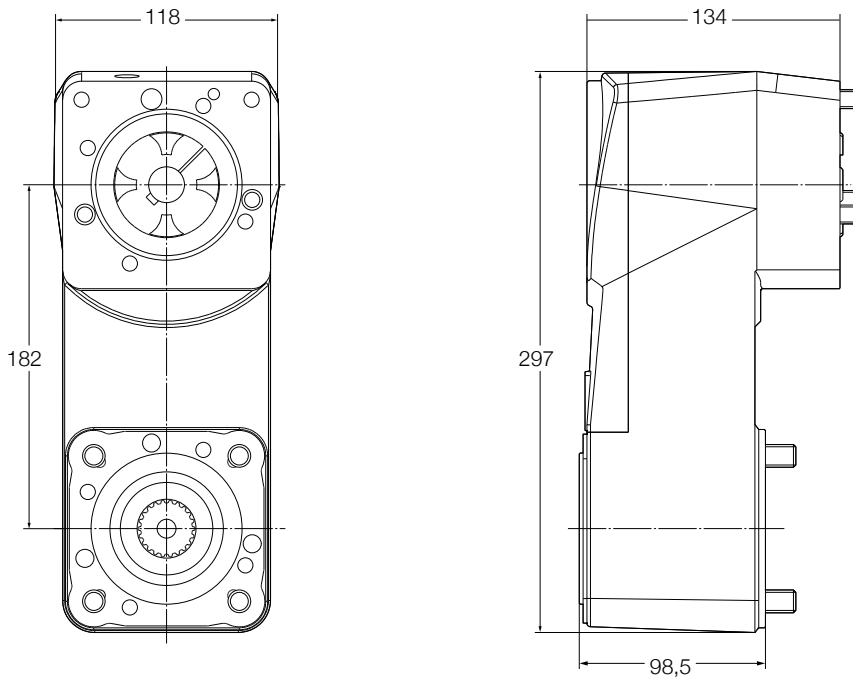

All dimensions in mm

Complete actuator

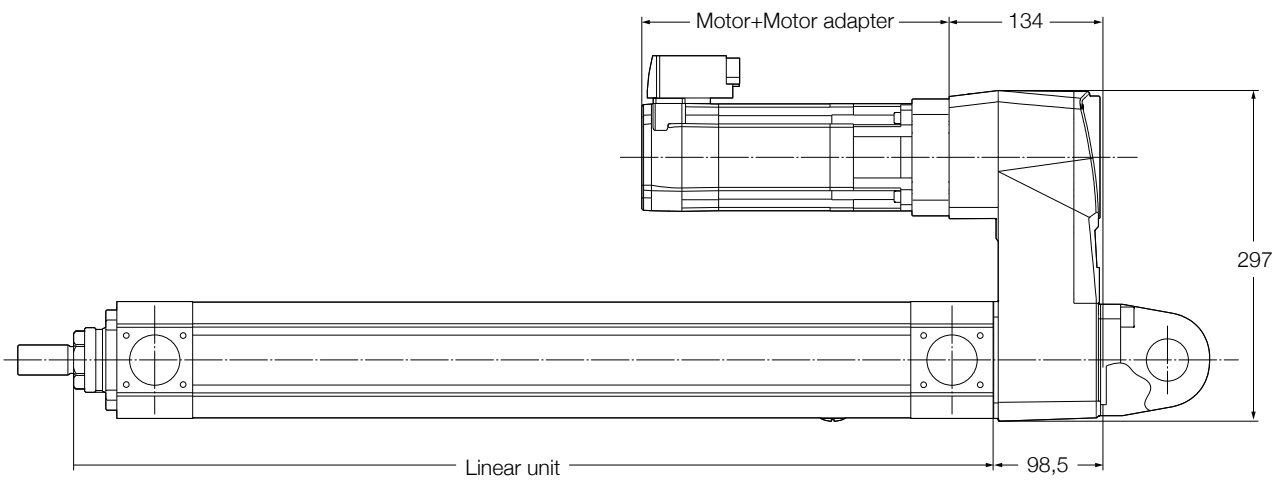

All dimensions in mm

Examples of linear unit, parallel gearbox and IEC AC motor combinations

The table below is a guidance to understand the performance levels that can be reached by using CAM-GS gearbox with standard IEC AC asynchronous motors, in terms of maximum dynamic axial force and linear speed.

In particular, by selecting the desired force and speed range, it's possible to quickly see which combination of screw, gearbox and asynchronous AC motors fulfills the application needs. This is a generic guidance, while the detailed performance values of each mentioned combination should be calculated.

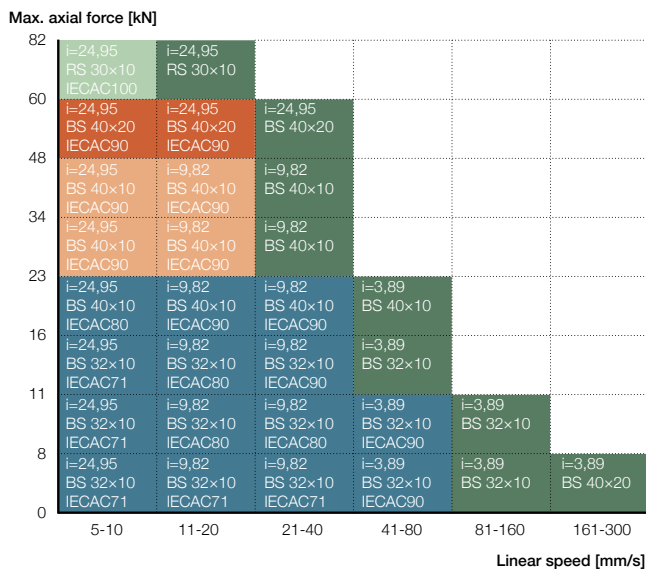

i = Gear reduction
 BS = Ball screw diameter x lead
 RS = Roller screw diameter x lead
 IEC = International Electrotechnical Commission AC motor standard

■ Third party motor required, with higher power than Ewellix selected motors

Example

Selected performance values

- Max dynamic axial force: = 34 kN
- Linear speed: = 11 - 20 mm/s

Resulting combination

- Gear reduction: 9,82
- Screw type: Ball screw
- Screw diameter: 40 mm
- Screw lead: 10 mm
- Motor type: Asynchronous AC
- Motor size: IEC AC 90

Ordering key

Gearbox

C A S M - G I - A A A - 0 0 - 0 0 0

Type:

- I Inline
- S Parallel (Spur gear)

Gear size

- A Inline Servo
- B Inline AC
- C Parallel (Spur gear)

Ratio

- A 1:1 (Inline)
- B 3,89:1 (Only for parallel)
- C 9,82:1 (Only for parallel)
- D 24,95:1 (Only for parallel)

Housing Material

- A Aluminium

Attachment¹⁾

- 0 No
- B Rear 0° (Only for parallel)
- C Rear 90° (Only for parallel)

Accessories

- 0 No
- B Brake (Only for parallel)

¹⁾ See fig. 4

Mounting position parallel gearbox rear attachment

The 0° reference for the parallel gearbox rear attachment is the gearbox itself.

The rear attachment can be turned in 90° step.(→ fig. 4).

Fig. 4

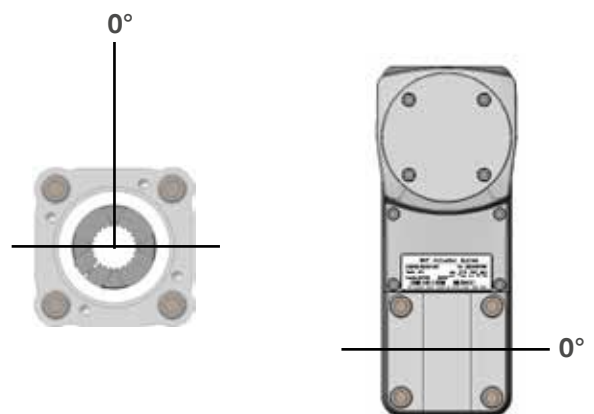

Gearbox orientation

Complete actuator combinations

The built-in modularity of the CASM-100 actuator allows customers to create tailor-made solutions through a vast number of standard components.

Considering the different types and sizes of screws, gear-boxes, motors, push tubes, bearing units, sealing kits and attachments available, hundreds of combinations are possible. Each of them can deliver a unique performance to fulfill even the most demanding application requirements.

For that reason, the following pages are presenting data-sheets only or the linear units for one of the possible actuator combinations (i.e. linear units with 4 screws - inline adapter - servo motors), as an example.

To create the optimal actuator combination for your application, the CASM-100 configurator is the best supporting tool. The software is available on www.skf.com/actuator-select in the section CASM-100 CONFIGURATOR.



Manuals

Supporting documents are available for download on ewellix.com

- operating manual

3D models

Product configurators for 3D models are available on ewellix.com



Operating manual

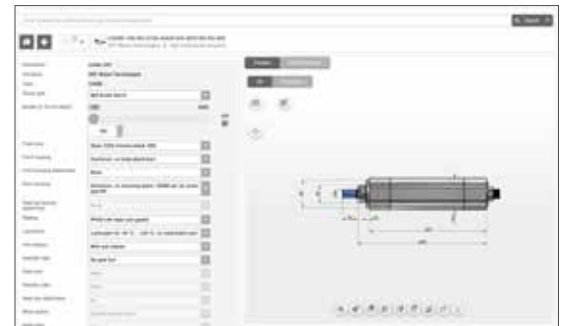

3D model configurator

CASM-100

Linear unit



Technical data

Designation	Symbol	Unit	CASM-100-BA	CASM-100-BB	CASM-100-BC	CASM-100-RA
Performance Data						
Max. dynamic axial force ¹⁾	F_{max}	kN	23	48	60	82
Max. dynamic axial force L10 ²⁾	F_{L10}	kN	22	47	60	50
Max. static axial force	F_{0max}	kN	52	60	60	82
Dynamic load capacity	C	kN	27,1	61,5	41,3	106
Maximum torque to reach F_{max}	T_{max}	Nm	43	90	225	163
Max. linear speed	v_{max}	mm/s	260	210	750	890
Max. rotational speed	n_{max}	1/min	1 560	1 260	2 250	5 340
Max. acceleration	a_{max}	m/s ²	6	6	12	12
Duty cycle	D_{unit}	%	100	100	100	100
Mechanical Data						
Screw type	–	–	Ball screw	Ball screw	Ball screw	Roller screw
Screw diameter	d_{screw}	mm	32	40	40	30
Screw lead	p_{screw}	mm	10	10	20	10
Lead accuracy	–	–	G9	G9	G9	G5
Stroke ³⁾	s	mm	100...2 000	100...2 000	100...2 000	100...2 000
Internal overstroke each side	s_0	mm	2	2	2	2
Backlash	$s_{backlash}$	mm	0,2	0,2	0,2	0,2
Efficiency	η_{lu}	%	>85	>85	>85	>80
Inertia @ 0 mm stroke	J_{lu}	kgm ²	0,00041	0,00051	0,00051	0,00045
Δ Inertia per 100 mm	ΔJ	kgm ²	0,000064	0,000144	0,000138	0,000063
Weight @ 0 mm stroke	m_{lu}	kg	11	12,7	12,3	12,5
Δ weight per 100 mm	Δm	kg	2,4	2,7	2,7	2,4
Environment						
Ambient temperature	$T_{ambient}$	°C	-40...+50	-40...+50	-40...+50	-40...+50
Max. humidity	ϕ	%	95	95	95	95
Degree of protection	IP	-	54S	54S	54S	54S

1) buckling limitation for long strokes, also limited by accessories and configurations. Please check the CASM-100 configuration tool on ewellix.com

2) Maximum dynamic axial force usable to apply the theoretical lifetime calculation (L10)

3) standard stroke lengths: 50; 100; 150; 200; 250; 300; 350; 400; 450; 500; 600; 700; 800; 900; 1 000; 1 500; 2 000 mm.
Other stroke lengths on request

Dimensional drawing

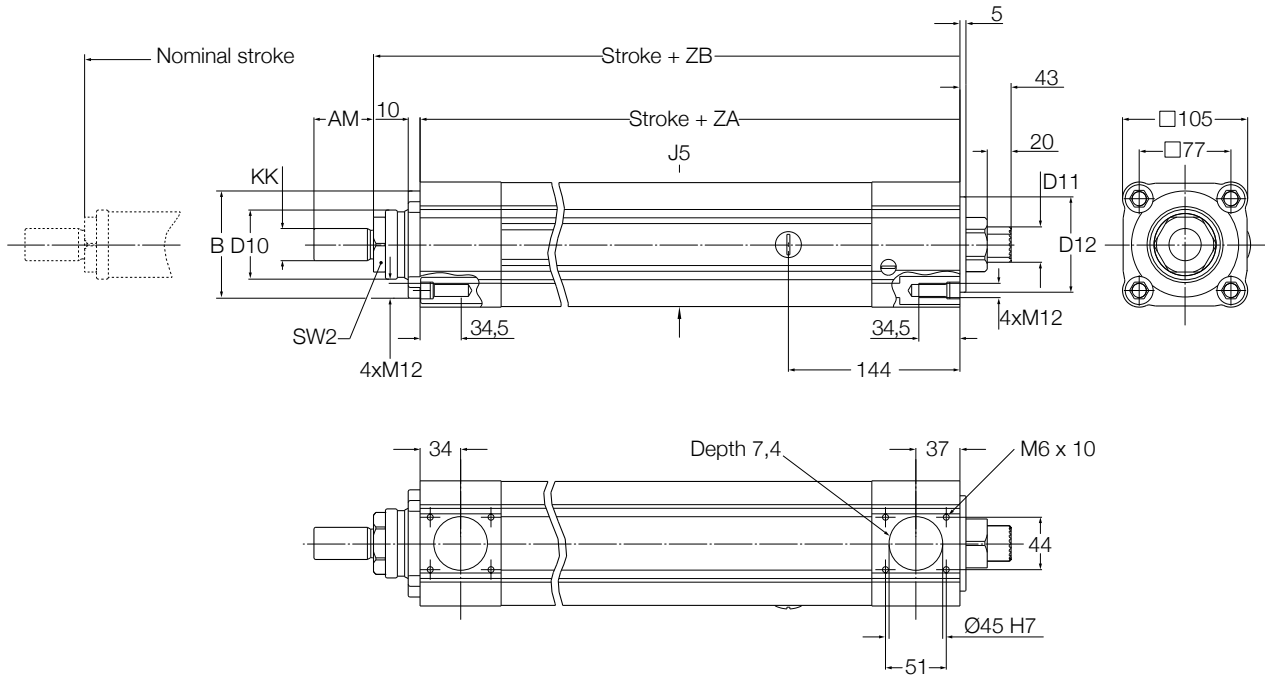

Linear Unit	KK	SW2	J5	ZA	ZB	B	D10	AM	D12	D11
-	-	-	mm							-
CASM-100-xx-xxxx-A...	M27x2	AF 46	□ 104	287±1,5	326±2	Ø90 ^{-0,10} _{-0,35}	Ø58	50	Ø80 ⁻⁰ _{-0,05}	Spline DIN 5480 W 30x1,25x22x8f
CASM-100-xx-xxxx-B...	M42x2	AF 60	□ 104	336±1,5	326±2	Ø90 ^{-0,10} _{-0,35}	Ø73	65	Ø80 ⁻⁰ _{-0,05}	Spline DIN 5480 W 30x1,25x22x8f

Performance diagrams

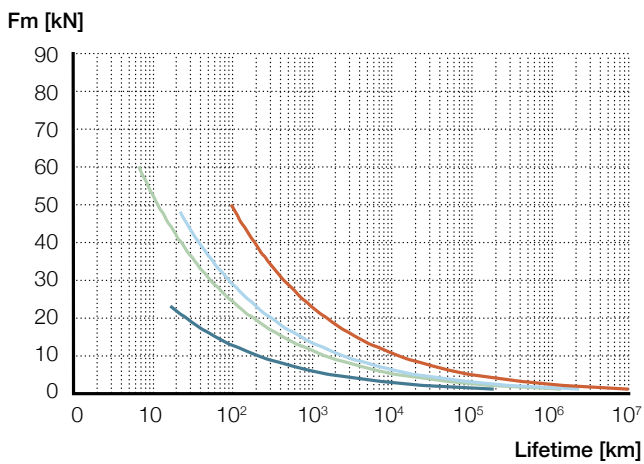

- CASM-100-BA
- CASM-100-BC
- CASM-100-BB
- CASM-100-RA

Ordering key: See ↪ page 142

Ordering key

Linear unit

C A S M - **1 0 0** - **B C** - **0 1 0 0** - **A A 0 C 1 0 A** - **B A 1 1 0 0** - **0 0 0**

Size _____

Screw type _____

BA Ball screw 32×10
 BB Ball screw 40×10
 BC Ball screw 40×20
 RA Roller screw 30×10

Stroke _____

- Stroke in mm

Push tube _____

A Steel E355 chrome plated, Ø55

Front housing and attachments _____

A Aluminium, no mounting option
 B Aluminium, with body attachment

Front housing attachment¹⁾ _____

0 None
 A Front plate 90° mounting position
 B Front plate 0° mounting position
 C Pivot attachment (trunnion brackets to be ordered separately)
 D Foot mount, 0° mounting position
 E Foot mount, 180° mounting position

Rear housing²⁾ _____

A1³⁾ Aluminium, no mounting option, DGBB set, for screw type BA
 B1³⁾ Aluminium, prepared for pivot or foot mounting, DGBB set, for screw type BA
 C1 Aluminium, no mounting option, ACBB set, for all screw types
 D1 Aluminium, prepared for pivot or foot mounting, ACBB set, for all screw types

Rear housing attachment¹⁾ _____

0 None
 C Pivot attachment (trunnion brackets to be ordered separately)
 D Foot mount, 0° mounting position
 E Foot mount, 180° mounting position

Protection tube _____

A Aluminium, 90°, recommended for parallel
 B Aluminium, 180°
 C Aluminium, 270°
 D Aluminium, 0°, recommended for inline

¹⁾ See fig. 5, page 137.
²⁾ DGBB means Deep Groove Ball Bearing; ACBB means Angular Contact Ball Bearing.
³⁾ Maximum static axial force limited to 31 kN.

C A S M - 1 0 0 - B C - 0 1 0 0 - A A 0 C 1 0 A - B A 1 1 0 0 - 0 0 0

Sealing

B IP54S with wiper and gasket

Lubrication

A0 Lubrication for -40 °C ...+50 °C, no re-lubrication possibility

A1 Lubrication for -40 °C ...+50 °C, with re-lubrication possibility

Anti-rotation

0 No anti-rotation

1 With anti-rotation

Free Parameter

00 Empty

Mounting position front plate and foot mount

The 0° reference for the linear unit is the sinter filter position. The front plate can be turned in 90° steps clockwise. The foot mount can be turned in 180° steps clockwise.

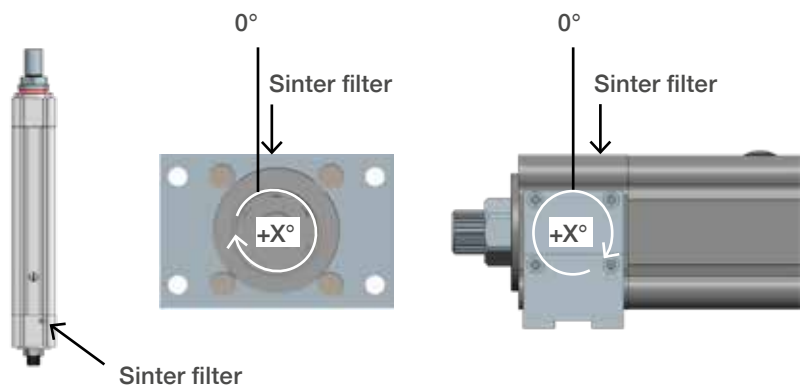

Fig. 5

CASM-100-BA

Electric cylinder
servo motor, inline configuration



Technical data

Designation	Symbol	Unit	1FK7044	1FK7064	1FK7086	1FK7105
Performance Data						
Continuous force @ zero speed	F_{c0}	kN	2,4	6,4	15,0	23,0
Continuous force @ max. speed	F_c	kN	2,2	5,9	11,2	21,4
Peak force @ zero speed	F_{p0}	kN	7	17,1	23,0	23
Peak force @ max. speed	F_p	kN	7	17,1	23,0	23
Dynamic load capacity	C	kN	27,1	27,1	27,1	27,1
Holding force	F_{Hold}	kN	3,5	9,1	16,1	23
Max. linear speed	v_{max}	mm/s	260	260	260	260
Max. acceleration	a_{max}	m/s ²	6	6	6	6
Duty cycle	D	%	100	100	100	100
Mechanical Data						
Screw type	-	-	Ball screw	Ball screw	Ball screw	Ball screw
Screw diameter	d_{screw}	mm	32	32	32	32
Screw lead	p_{screw}	mm	10	10	10	10
Lead accuracy	-	-	G9	G9	G9	G9
Stroke ¹⁾	s	mm	100...2 000	100...2 000	100...2 000	100...2 000
Internal overstroke each side	s0	mm	2	2	2	2
Backlash	$s_{backlash}$	mm	0,2	0,2	0,2	0,2
Gear reduction	i	-	1	1	1	1
Efficiency	η	%	77	79	79	80
Inertia @ 0 mm stroke	J	10 ⁻⁴ kgm ²	6,16	12,4	26,9	159
Δ Inertia per 100 mm	ΔJ	10 ⁻⁴ kgm ²	0,64	0,64	0,64	0,64
Inertia of optional brake	J_{brake}	10 ⁻⁴ kgm ²	0,36	1	3,50	8
Weight @ 0 mm stroke	m	kg	19,8	28,7	37,8	56,4
Δ weight per 100 mm	Δm	kg	2,4	2,4	2,4	2,4
Weight of optional brake	m_{brake}	kg	0,6	1,4	3,0	4,5
Electrical Data						
Motor type	-	-	Servo	Servo	Servo	Servo
Nominal voltage	U	V DC	600	600	600	600
Nominal current	I	A	3,9	7,6	5,7	18
Peak current	I_{peak}	A	5,4	10,8	21,5	31
Nominal power	P	kW	1,4	2,5	3,75	8,2
Environment & Standards						
Ambient temperature	$T_{ambient}$	°C	-40...+50	-40...+50	-40...+50	-40...+50
Max. humidity	ϕ	%	95	95	95	95
Degree of protection	IP	-	64	64	64	64

¹⁾ standard stroke lengths: 100; 200; 300; 400; 500; 600; 800; 1 000; 1 500; 2 000 mm. Other stroke lengths on request

Performance diagrams

Axial force [N]

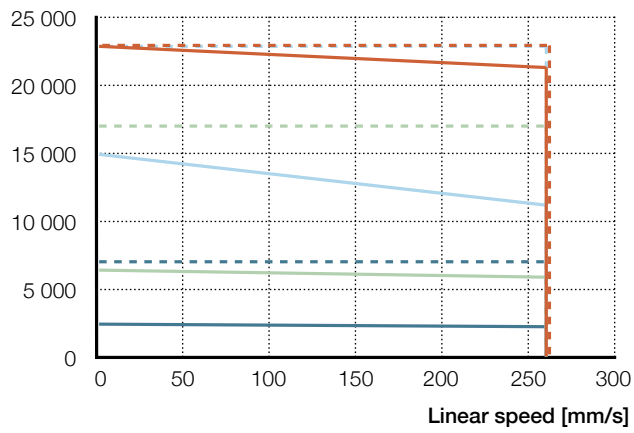

1FK7044 — F_{cont} — F_{peak}

1FK7064 — F_{cont} — F_{peak}

1FK7086 — F_{cont} — F_{peak}

1FK7105 — F_{cont} — F_{peak}

Dimensional drawing

See [↪](#) page 152

Ordering key: See [↪](#) page 156

CASM-100-BB

Electric cylinder
servo motor, inline configuration



Technical data

Designation	Symbol	Unit	1FK7044	1FK7064	1FK7086	1FK7105
Performance Data						
Continuous force @ zero speed	F_{c0}	kN	2,4	6,4	14,9	25,6
Continuous force @ max. speed	F_c	kN	2,2	6,1	12,8	21,9
Peak force @ zero speed	F_{p0}	kN	6,9	17,1	48,0	48
Peak force @ max. speed	F_p	kN	6,9	17,1	48,0	48
Dynamic load capacity	C	kN	61,5	61,5	61,5	61,5
Holding force	F_{Hold}	kN	3,5	9,1	16,1	29,3
Max. linear speed	v_{max}	mm/s	210	210	210	210
Max. acceleration	a_{max}	m/s ²	6	6	6	6
Duty cycle	D	%	100	100	100	100
Mechanical Data						
Screw type	-	-	Ball screw	Ball screw	Ball screw	Ball screw
Screw diameter	d_{screw}	mm	40	40	40	40
Screw lead	p_{screw}	mm	10	10	10	10
Lead accuracy	-	-	G9	G9	G9	G9
Stroke ¹⁾	s	mm	100...2 000	100...2 000	100...2 000	100...2 000
Internal overstroke each side	s0	mm	2	2	2	2
Backlash	$s_{backlash}$	mm	0,2	0,2	0,2	0,2
Gear reduction	i	-	1	1	1	1
Efficiency	η	%	77	79	79	80
Inertia @ 0 mm stroke	J	10 ⁻⁴ kgm ²	7,16	13,4	27,9	160
Δ Inertia per 100 mm	ΔJ	10 ⁻⁴ kgm ²	1,44	1,44	1,44	1,44
Inertia of optional brake	J_{brake}	10 ⁻⁴ kgm ²	0,36	1	3,5	8
Weight @ 0 mm stroke	m	kg	21,5	30,4	39,5	58,1
Δ weight per 100 mm	Δm	kg	2,7	2,7	2,7	2,7
Weight of optional brake	m_{brake}	kg	0,6	1,4	3,0	4,5
Electrical Data						
Motor type	-	-	Servo	Servo	Servo	Servo
Nominal voltage	U	V DC	600	600	600	600
Nominal current	I	A	3,9	7,6	5,7	18
Peak current	I_{peak}	A	5,4	10,8	21,5	31
Nominal power	P	kW	1,4	2,5	3,75	8,2
Environment & Standards						
Ambient temperature	$T_{ambient}$	°C	-40...+50	-40...+50	-40...+50	-40...+50
Max. humidity	φ	%	95	95	95	95
Degree of protection	IP	-	64	64	64	64

¹⁾ standard stroke lengths: 100; 200; 300; 400; 500; 600; 800; 1 000; 1 500; 2 000 mm. Other stroke lengths on request

Performance diagrams

Axial force [N]

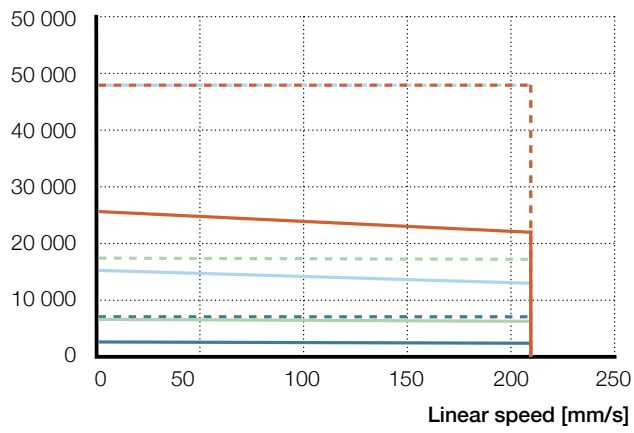

1FK7044 — F_{cont} — F_{peak}

1FK7064 — F_{cont} — F_{peak}

1FK7086 — F_{cont} — F_{peak}

1FK7105 — F_{cont} — F_{peak}

Dimensional drawing

See [↪](#) page 152

Ordering key: See [↪](#) page 156

CASM-100-BC

Electric cylinder
servo motor, inline configuration



Technical data

Designation	Symbol	Unit	1FK7044	1FK7064	1FK7086	1FK7105
Performance Data						
Continuous force @ zero speed	F_{c0}	kN	1,2	3,2	7,5	12,8
Continuous force @ max. speed	F_c	kN	1,1	2,5	4	9,3
Peak force @ zero speed	F_{p0}	kN	3,5	8,5	28	40
Peak force @ max. speed	F_p	kN	3,5	8	26,7	40
Dynamic load capacity	C	kN	41,3	41,3	41,3	41,3
Holding force	F_{Hold}	kN	1,7	4,5	8	14,7
Max. linear speed	v_{max}	mm/s	750	750	750	750
Max. acceleration	a_{max}	m/s ²	12	12	12	12
Duty cycle	D	%	100	100	100	100
Mechanical Data						
Screw type	-	-	Ball screw	Ball screw	Ball screw	Ball screw
Screw diameter	d_{screw}	mm	40	40	40	40
Screw lead	p_{screw}	mm	20	20	20	20
Lead accuracy	-	-	G9	G9	G9	G9
Stroke ¹⁾	s	mm	100...2 000	100...2 000	100...2 000	100...2 000
Internal overstroke each side	s0	mm	2	2	2	2
Backlash	$s_{backlash}$	mm	0,2	0,2	0,2	0,2
Gear reduction	i	-	1	1	1	1
Efficiency	η	%	77	79	79	80
Inertia @ 0 mm stroke	J	10 ⁻⁴ kgm ²	7,16	13,4	27,9	160
Δ Inertia per 100 mm	ΔJ	10 ⁻⁴ kgm ²	1,38	1,38	1,38	1,38
Inertia of optional brake	J_{brake}	10 ⁻⁴ kgm ²	0,36	1	3,5	8
Weight @ 0 mm stroke	m	kg	21,1	30	39,1	57,7
Δ weight per 100 mm	Δm	kg	2,7	2,7	2,7	2,7
Weight of optional brake	m_{brake}	kg	0,6	1,4	3	4,5
Electrical Data						
Motor type	-	-	Servo	Servo	Servo	Servo
Nominal voltage	U	V DC	600	600	600	600
Nominal current	I	A	3,9	7,6	5,7	18
Peak current	I_{peak}	A	5,4	10,8	21,5	31
Nominal power	P	kW	1,4	2,5	3,75	8,2
Environment & Standards						
Ambient temperature	$T_{ambient}$	°C	-40...+50	-40...+50	-40...+50	-40...+50
Max. humidity	ϕ	%	95	95	95	95
Degree of protection	IP	-	64	64	64	64

¹⁾ standard stroke lengths: 100; 200; 300; 400; 500; 600; 800; 1 000; 1 500; 2 000 mm. Other stroke lengths on request

Performance diagrams

Axial force [N]

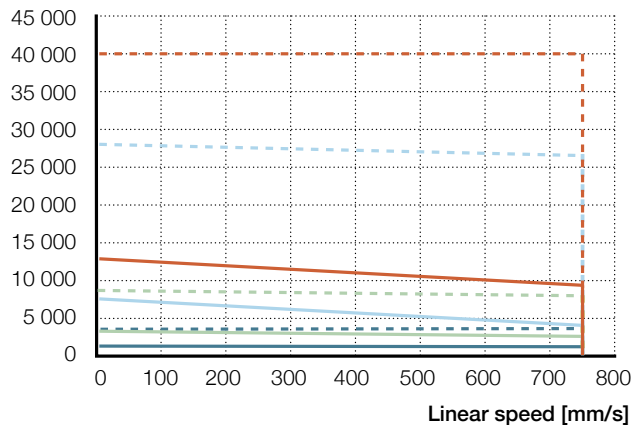

1FK7044 — F_{cont} — F_{peak}

1FK7064 — F_{cont} — F_{peak}

1FK7086 — F_{cont} — F_{peak}

1FK7105 — F_{cont} — F_{peak}

Dimensional drawing

See [L](#) page 152

Ordering key: See [L](#) page 156

CASM-100-RA

Electric cylinder
servo motor, inline configuration



Technical data

Designation	Symbol	Unit	1FK7044	1FK7064	1FK7086	1FK7105
Performance Data						
Continuous force @ zero speed	F_{c0}	kN	2,3	6,0	14,1	24,1
Continuous force @ max. speed	F_c	kN	1,5	4,0	3,5	13,1
Peak force @ zero speed	F_{p0}	kN	6,5	16,1	52,8	75,5
Peak force @ max. speed	F_p	kN	6,3	11,6	39,2	75
Dynamic load capacity	C	kN	106,0	106,0	106	106,0
Holding force	F_{Hold}	kN	3,7	9,6	17	31
Max. linear speed	v_{max}	mm/s	750	500	500	500
Max. acceleration	a_{max}	m/s ²	12	12	12	12
Duty cycle	D	%	100	100	100	100
Mechanical Data						
Screw type	-	-	Roller screw	Roller screw	Roller screw	Roller screw
Screw diameter	d_{screw}	mm	30	30	30	30
Screw lead	p_{screw}	mm	10	10	10	10
Lead accuracy	-	-	G5	G5	G5	G5
Stroke ¹⁾	s	mm	100...2 000	100...2 000	100...2 000	100...2 000
Internal overstroke each side	s0	mm	2	2	2	2
Backlash	$s_{backlash}$	mm	0,2	0,2	0,2	0,2
Gear reduction	i	-	1	1	1	1
Efficiency	η	%	73	74	74	75
Inertia @ 0 mm stroke	J	10 ⁻⁴ kgm ²	6,56	12,8	27,3	159
Δ Inertia per 100 mm	ΔJ	10 ⁻⁴ kgm ²	0,63	0,63	0,63	0,63
Inertia of optional brake	J_{brake}	10 ⁻⁴ kgm ²	0,36	1	3,5	8
Weight @ 0 mm stroke	m	kg	21,3	30,2	39,3	57,9
Δ weight per 100 mm	Δm	kg	2,4	2,4	2,4	2,4
Weight of optional brake	m_{brake}	kg	0,6	1,4	3,0	4,5
Electrical Data						
Motor type	-	-	Servo	Servo	Servo	Servo
Nominal voltage	U	V DC	600	600	600	600
Nominal current	I	A	3,9	7,6	5,7	18
Peak current	I_{peak}	A	5,4	10,8	21,5	31
Nominal power	P	kW	1,4	2,5	3,75	8,2
Environment & Standards						
Ambient temperature	$T_{ambient}$	°C	-40...+50	-40...+50	-40...+50	-40...+50
Max. humidity	ϕ	%	95	95	95	95
Degree of protection	IP	-	64	64	64	64

¹⁾ standard stroke lengths: 100; 200; 300; 400; 500; 600; 800; 1 000; 1 500; 2 000 mm. Other stroke lengths on request

Performance diagrams

Axial force [N]

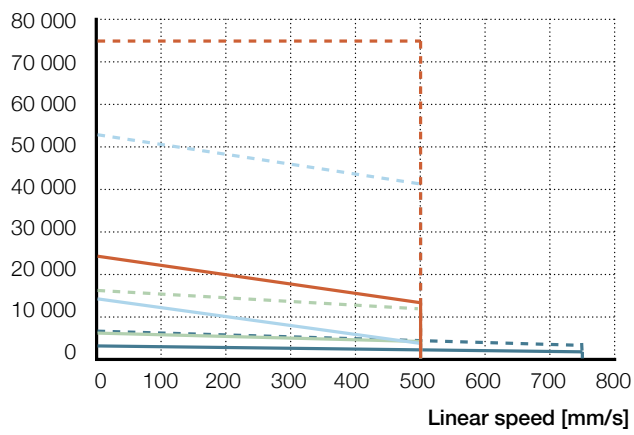

1FK7044 F_{cont} F_{peak}

1FK7064 F_{cont} F_{peak}

1FK7086 F_{cont} F_{peak}

1FK7105 F_{cont} F_{peak}

Dimensional drawing

See \hookrightarrow page 152

Ordering key: See \hookrightarrow page 156

Dimensional drawing

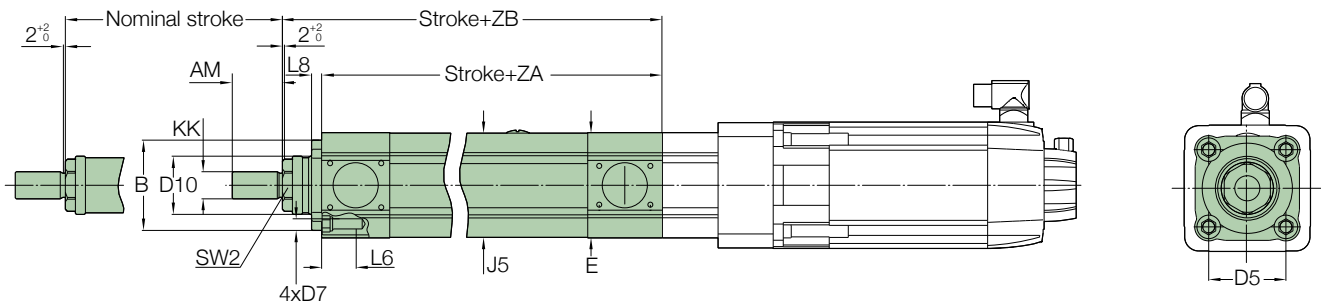

Linear Unit	KK	SW 2	D7	J5	E	ZA	ZB	L8	B	D10	AM	D5	L6
-	-	-	-	mm									
CASM-100-xx-xxxx-A...	M27x2	AF 46	M12	□ 104	□ 105	287±1,5	326±2	10	Ø90 ^{-0,10} _{-0,35}	Ø58	50	□ 77	34,5
CASM-100-xx-xxxx-B...	M42x2	AF 60	M12	□ 104	□ 105	287±1,5	336±2	10	Ø90 ^{-0,10} _{-0,35}	Ø73	65	□ 77	34,5

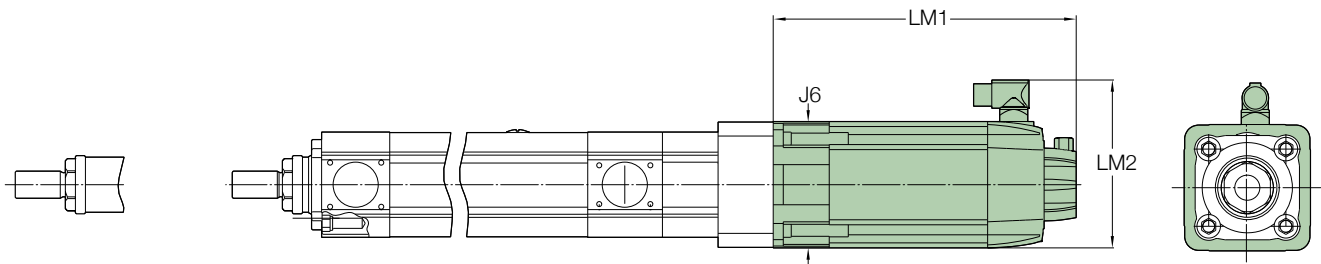

Motor	LM1	LM2	J6
-	mm		
CAM-MS-xO-A11-000	242,5	139,5	□ 96
CAM-MS-xO-A12-000	302,5	167,5	□ 126
CAM-MS-xO-A13-000	309,5	216,5	□ 155
CAM-MS-xO-A14-000	340	253	□ 192

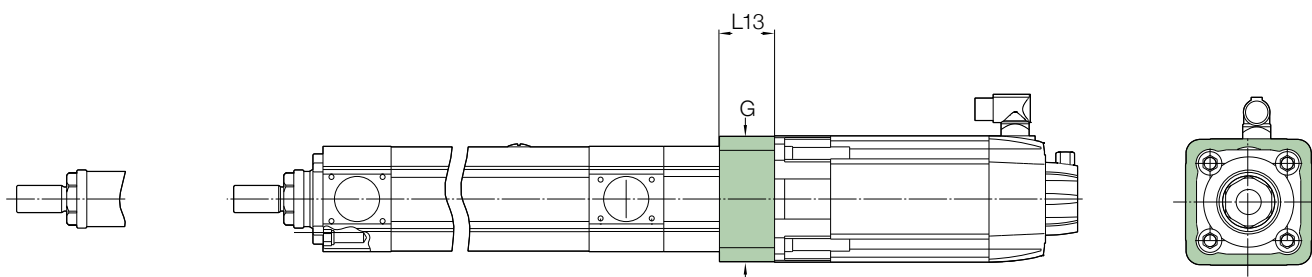

Motor adapter	G	L13
-	mm	
CAM-MS-xO-A11-000	□ 105	33,5
CAM-MS-xO-A12-000	□ 125	55,5
CAM-MS-xO-A13-000	□ 155	63,5
CAM-MS-xO-A14-000	□ 192,5	85,5

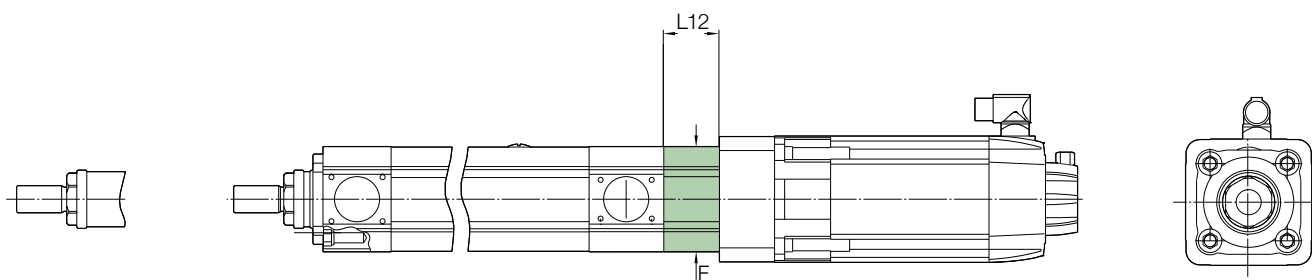

Gearbox	i	F	L12
-	-	mm	
CAM-GI-AAA-00-000	01:01	□105	55,5

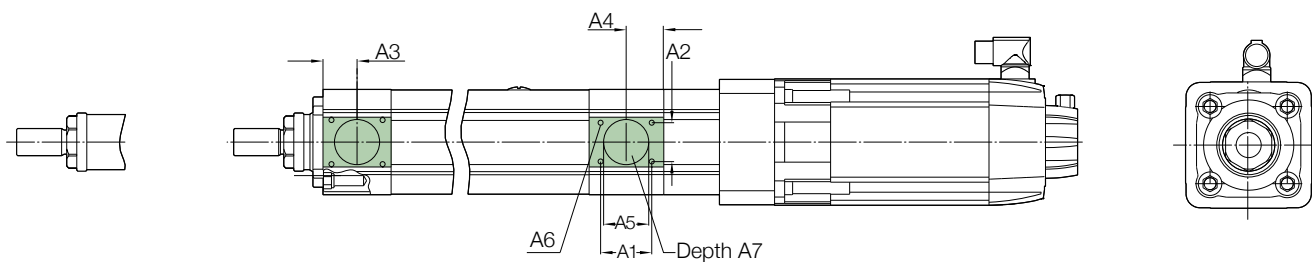

Optional Mounting Possibility	A6	A1	A2	A3	A4	A5	A7
-	-	mm					
CASM-100-xx-xxxx-...	M6x10	51	44	34	37	Ø45 H7	7,4

Mounting positions

For a complete actuator assembly, the gearbox is used as the 0° reference for all connected modules (↳ **fig. 6**).

Fig. 6

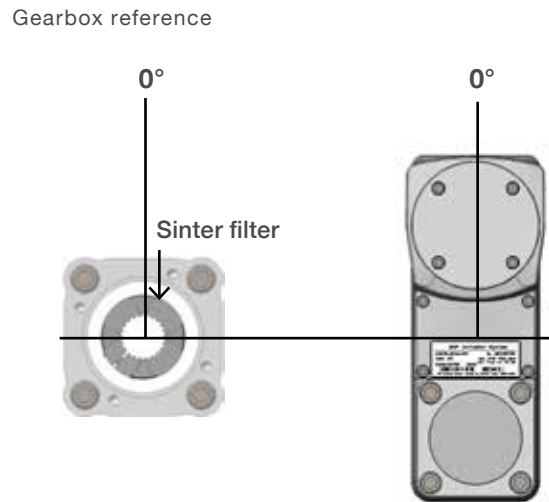

Mounting position protection tube

The 0° reference for the protection tube is the sinter filter position. The protection tube can be turned in 90° steps clockwise (↳ **fig. 7**). Parallel gearbox mounting positions have some limitations: protection with relubrication port can be mounted at 90° - 180° - 270° (0° is not possible) (↳ **fig. 8**).

Fig. 7

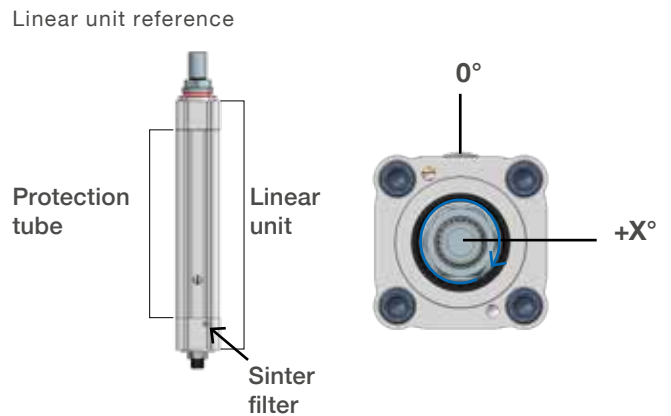
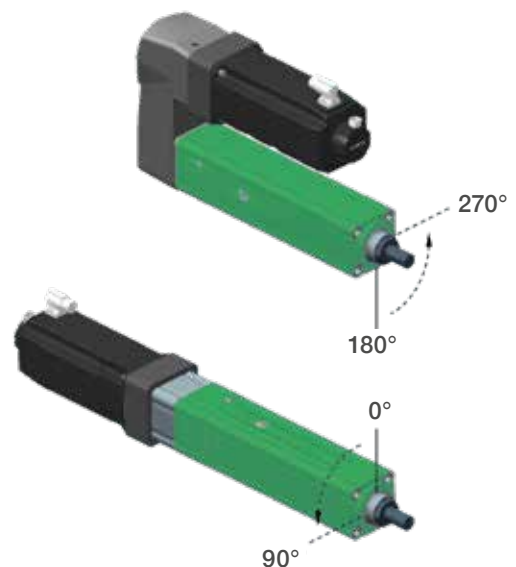

Fig. 8

Orientation recommendation

For parallel version, recommended linear unit mounting position is 0° and protection tube mounting position is 90° (270° also possible).

Linear unit orientation



Mounting positions motor

The 0° reference for the motor is the electric connector outlet position. The motor can be turned in 90° steps clockwise (↳ **fig. 9**). Parallel gearbox mounting position have some limitations: Motor from sizes Servo 8x / IEC AC 80 and bigger can be mounted at 0° - 90° - 270° (180° is not possible), (↳ **fig. 10**).

Fig. 9

Reference motor adapter

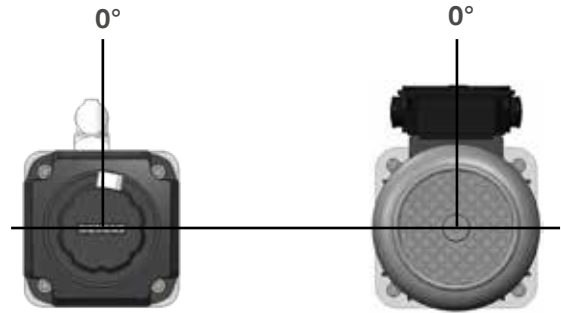

Fig. 10

Motor adapter orientation

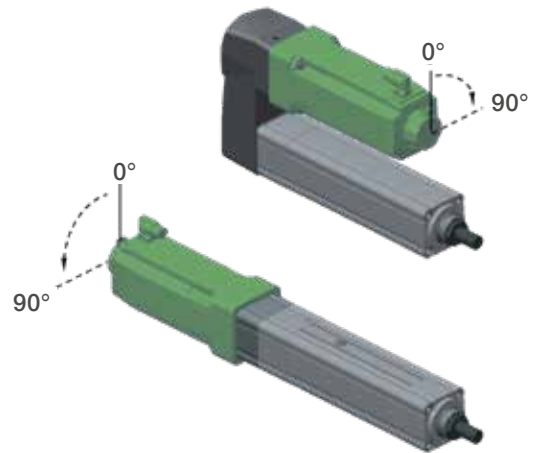
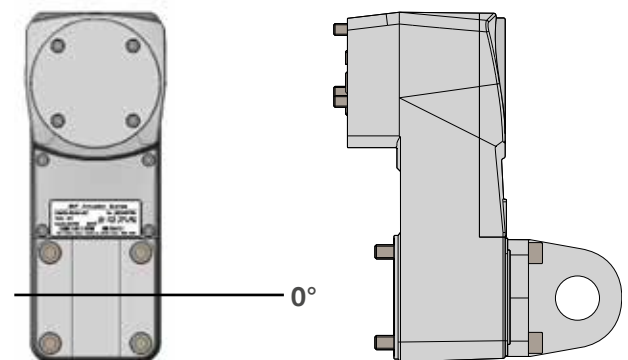

Fig. 11

Gearbox orientation



Mounting position parallel gearbox rear attachment

The 0° reference for the parallel gearbox rear attachment is the gearbox itself.

The rear attachment can be turned in 90° step (↳ **fig. 11**).

Ordering key

Complete actuator

C A S M - 1 0 0 - B C - 0 1 0 0 - A A 0 C 1 0 A - B A 1 1 0 0

Size

Screw type

- BA Ball screw 32×10
- BB Ball screw 40×10
- BC Ball screw 40×20
- RA Roller screw 30×10

Stroke

- Stroke in mm

Push tube

- A Steel E355 chrome plated, Ø55

Front housing and attachments

- A Aluminium, no mounting option
- B Aluminium, with body attachment

Front housing attachment¹⁾

- 0 None
- A Front plate 90° mounting position
- B Front plate 0° mounting position
- C Pivot attachment (trunnion brackets to be ordered separately)
- D Foot mount, 0° mounting position
- E Foot mount, 180° mounting position

Rear housing²⁾

- A1³⁾ Aluminium, no mounting option, DGBB set, for screw type BA
- B1³⁾ Aluminium, prepared for pivot or foot mounting, DGBB set, for screw type BA
- C1 Aluminium, no mounting option, ACBB set, for all screw types
- D1 Aluminium, prepared for pivot or foot mounting, ACBB set, for all screw types

Rear housing attachment¹⁾

- 0 None
- C Pivot attachment (trunnion brackets to be ordered separately)
- D Foot mount, 0° mounting position
- E Foot mount, 180° mounting position

Protection tube

- A Aluminium, 90°, recommended for parallel
- B Aluminium, 180°
- C Aluminium, 270°
- D Aluminium, 0°, recommended for inline

Sealing

- B IP54S with wiper and gasket

Lubrication

- A0 Lubrication for -40 °C ...+50 °C, no re-lubrication possibility
- A1 Lubrication for -40 °C ...+50 °C, with re-lubrication possibility

Anti-rotation

- 0 No anti-rotation
- 1 With anti-rotation

Free Parameter

- 00 Empty

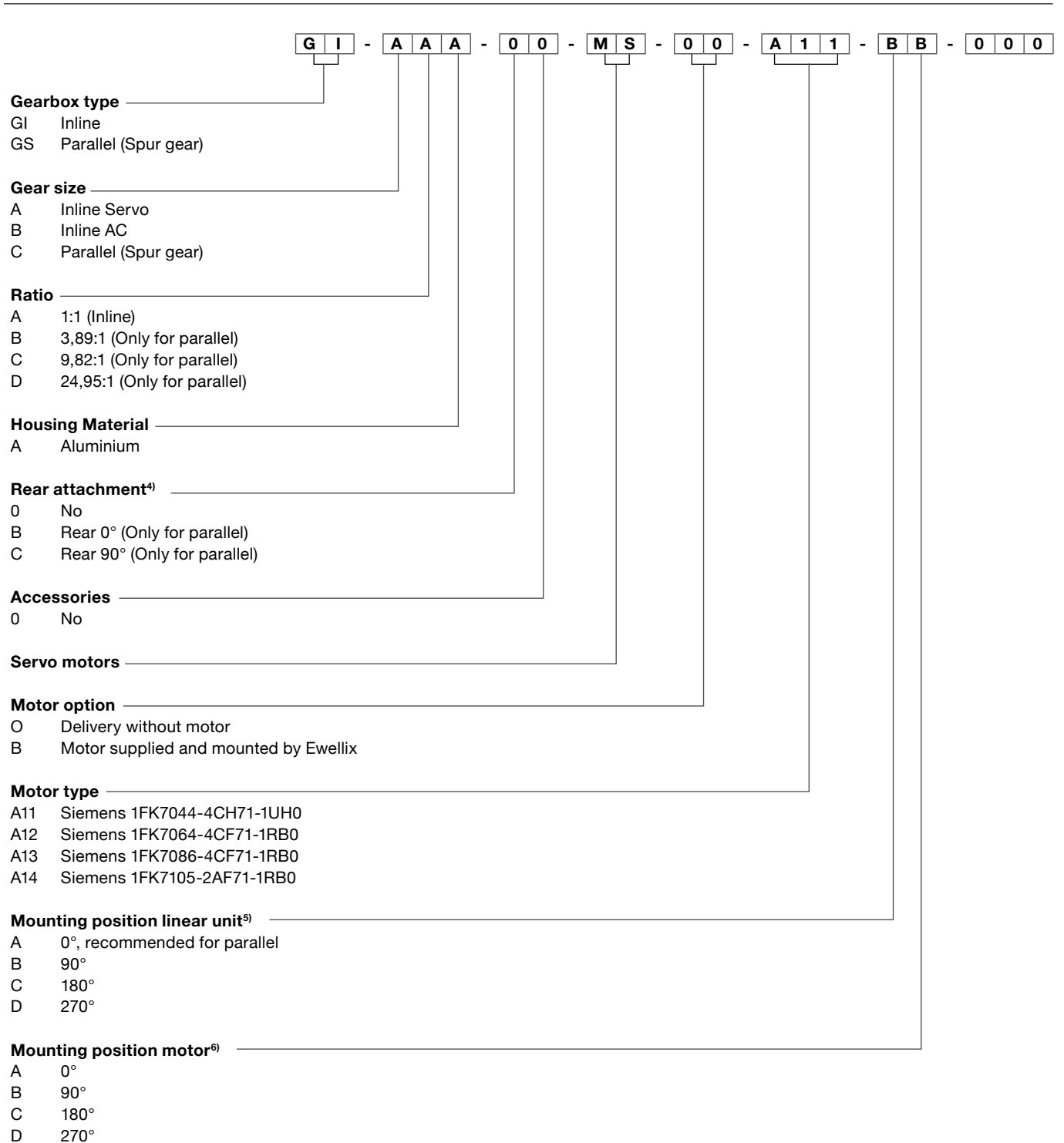

¹⁾ See fig. 5, page 137.
²⁾ DGBB means Deep Groove Ball Bearing; ACBB means Angular Contact Ball Bearing.
³⁾ Maximum static axial force limited to 31 kN.
⁴⁾ See fig. 11, page 139.
⁵⁾ See fig 7 and 8, page 138
⁶⁾ See fig 9 and 19, page 139

Fig. 5

Mounting position front plate and foot mount. The 0° reference for the linear unit is the sinter filter position. The front plate can be turned in 90° steps clockwise. The foot mount can be turned in 180° steps clockwise.

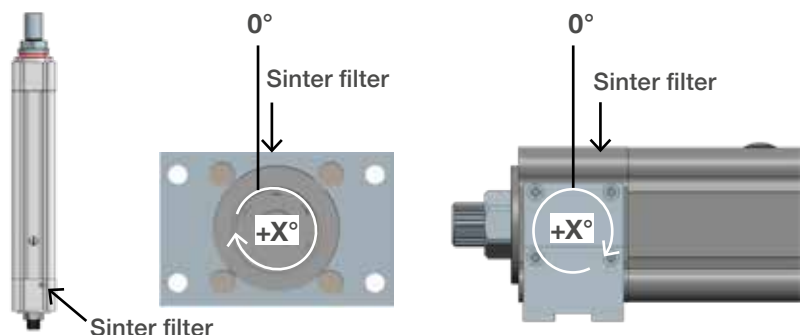

Accessories

CASM-100

Push tube attachments

Rod End

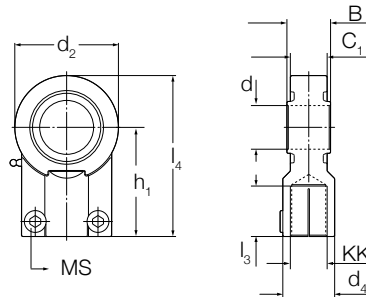

Ordering key

Rod End Ø32:
ZBE-377900
Rod End Ø50:
ZBE-377912
(According to DIN8132 standard)

Type	KK	MS	L ₃ mm	B	C ₁	d	d ₄	l ₄	h ₁	d ₂	m ₂ kg
ZBE-377900	M27x2	M10	37	32H7	29	Ø32	Ø40	116,5	80	76	1,1
ZBE-377912	M42x2	M12	57	50H7	42	Ø50	Ø60,5	175,5	120	110	3,7

Rod Clevis

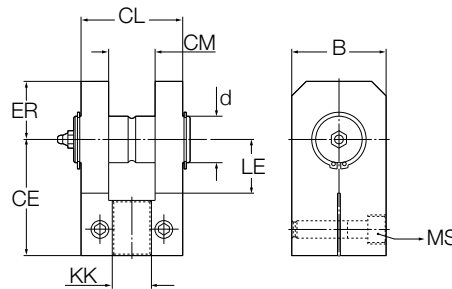

Ordering key

Rod Clevis Ø32:
ZBE-377917
Rod Clevis Ø50:
ZBE-377916
(According to DIN8132 standard)

Type	KK	MS	CL mm	CM	LE	CE	ER	d	B	m kg
ZBE-377917	M27x2	M12	70	32	42	80	40	Ø32f8	65	2,7
ZBE-377916	M42x2	M20	110	50	64	120	63	Ø50f8	100	6

Mounting kits

Pivot Attachment

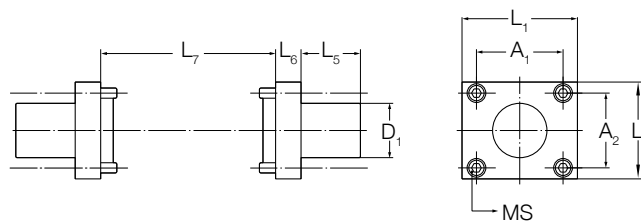

Ordering key

ZBE-377919

Type	MS	L ₁ mm	L ₂	A ₁	A ₂	L ₅	L ₆	L ₇	D ₁	m kg
ZBE-377919	M6x16	68	57	51	44	35	15	103	Ø32f7	1,5

Front Plate

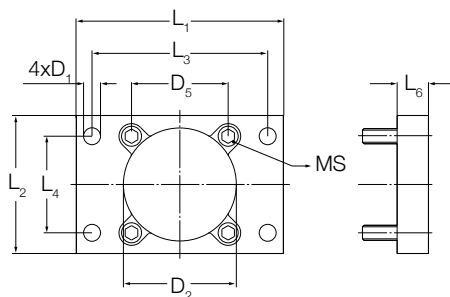

Ordering key
ZBE-377918

Type	MS	L ₁ mm	L ₂	L ₃	L ₄	D ₁	D ₅	D ₂	L ₆	m kg
ZBE-377918	M12x40	165	110	140	77	Ø13,5	77	Ø90	25	2,1

Proximity Switch

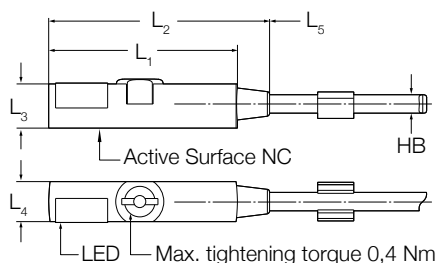

Ordering key
ZSC-377901-NC

Type	L ₁ mm	L ₂	L ₃	L ₄	L ₅	D ₁	m kg
ZSC-377901-NC	23,5	27	5,5	5	2 000	Ø2,5	0,016

Accessories Rear Attachment

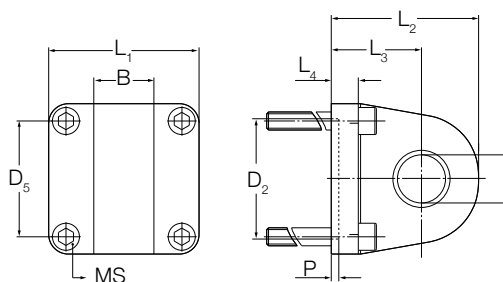

Ordering key
ZBE-377921

Type	MS	d mm	B	L ₁	L ₂	L ₃	L ₄	D ₂	P	D ₅	m kg
ZBE-377921	M12x140	Ø32 H7	40	□ 100	98	60	11	Ø80	5	□ 77	3

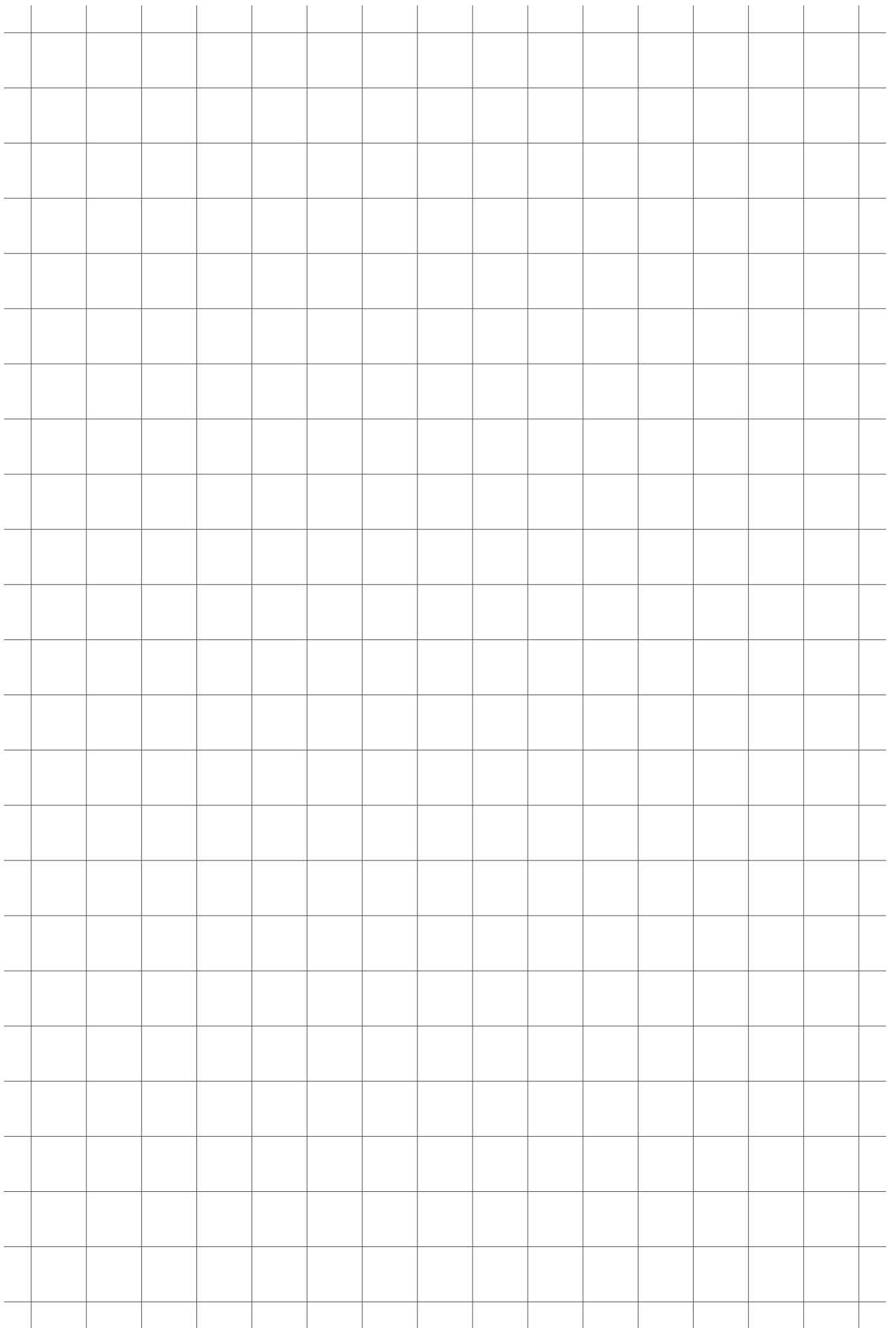

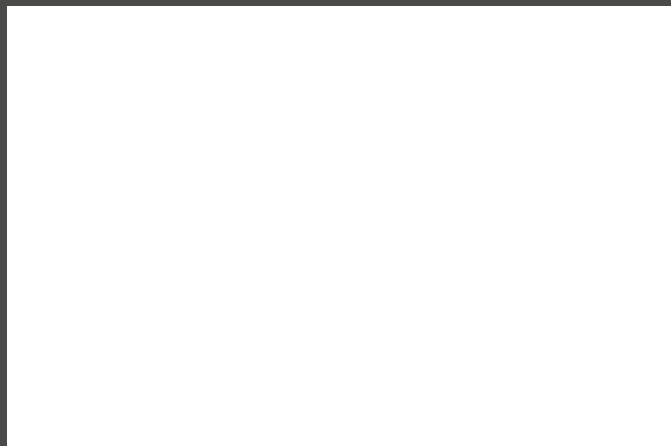

ewellix.com

© Ewellix

All contents of this publication are the property of Ewellix, and may not be reproduced or given to third parties (even extracts) without permission. Although great care has been taken in the production of this catalog, Ewellix does not take any responsibility for damage or other loss resulting from omissions or typographical errors. The photo may differ slightly in appearance from the actual product. Due to continuous improvements being made in our products, the product's appearance and specifications are subject to change without notice.

PUB IL-07016-EN-October 2019

Certain image(s) used under license from Shutterstock.com.
SKF and SKF logo are trademarks of the SKF Group