

EWELLIX

MAKERS IN MOTION

Linear axes for collaborative robots



Heritage of innovation for technology leadership

Ewellix is a global innovator and manufacturer of linear motion and actuation solutions. Today, our state-of-the-art linear solutions are designed to increase machine performance, maximise uptime, reduce maintenance, improve safety and save energy.

Technology leadership

Our journey began **over 50 years** ago as part of the SKF Group, and our history with SKF provided us with the **expertise to continuously develop new technologies** and use them to create cutting edge products that offer our customers a competitive advantage.

In 2019, we became independent from SKF and changed our name to Ewellix. **We are proud of our heritage.** This gives us a unique foundation on which to build an agile business with engineering excellence and innovation as our core strengths.

Global presence and local support

With our **global presence**, we are uniquely positioned to deliver **standard components and custom-engineered solutions**, with full technical and applications support around the world. The long lasting relationships with our distributor partners allow us to support customers in a variety of different industries. At Ewellix, we don't just provide products; **we engineer integrated solutions** that help customers realise their ambitions.



1 400 employees



16 sales units



9 factories

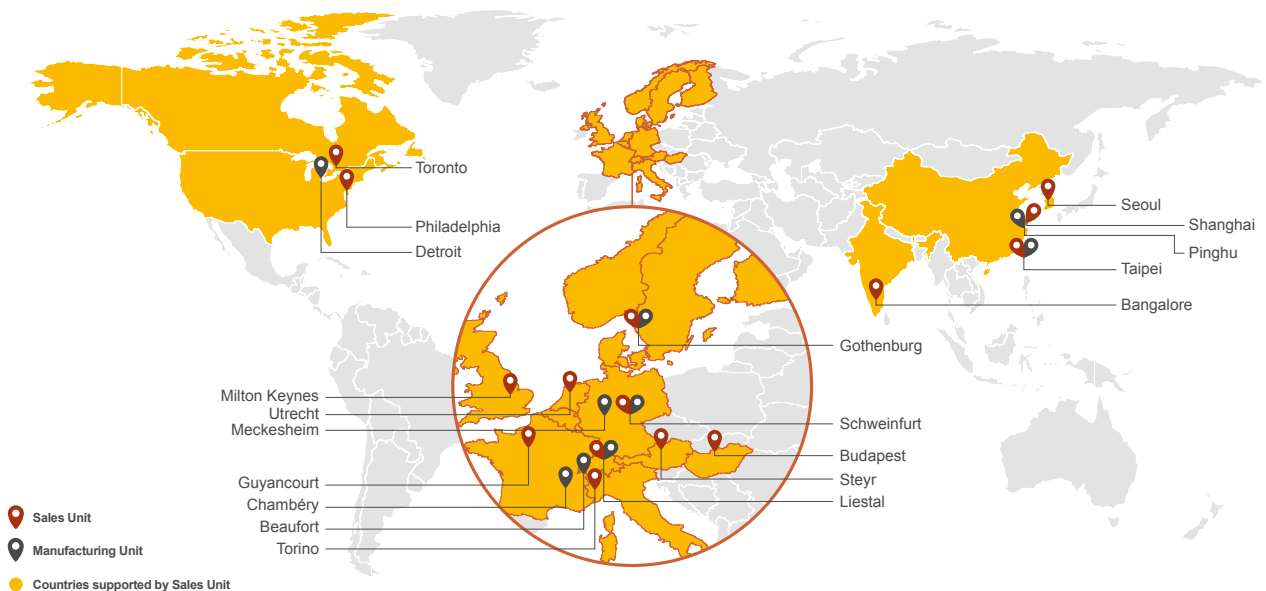

Applications

Industry 4.0 has driven a modernization of operations across different industries. Process automation is a key enabler to reach operational excellence with interconnected machineries.

Collaborative robots (cobots) can greatly improve productivity in industrial environments with repetitive tasks. The radius of action is usually limited by their reach. Additional linear axes can significantly enhance the radius of action up to 5 times, by re-positioning the base of the robot during its working cycle.

Ewellix offers a range of linear motion axes - vertical and horizontal - to easily expand the capabilities of a cobot.

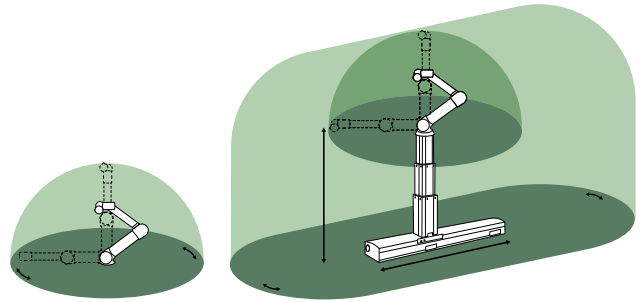

Benefits for palletizing

Fully automated pick and place solutions are becoming a new standard with packaging stations. The main challenge for packaging system manufacturers is to design multi-axis systems in a simple and cost effective way. A typical application that benefits from an added linear axis is palletizing of boxes. Stacking on pallets can start at floor level, but the stack can be up to 2 m high. A standard collaborative robot does not have such a large vertical working range.

Ewellix provides effective solutions to complete vertical adjustment in a smart way, providing a ready to mount additional linear axis to the robot. While stacking a pallet, the base of the robot can be lifted or lowered to work at a more optimal position.

Benefits for handling

Concerning handling applications, it's often required to cover long distances between machines, like machined parts loading and unloading on CNC centers.

This repetitive operation, usually done manually, is time consuming and with low added value for the operators.

By using a cobot on the Ewellix linear module, it is possible to easily automate this handling process, increasing its productivity and reliability.

Linear modules from Ewellix provide fast and precise movements to effectively position the robot along a horizontal axis.

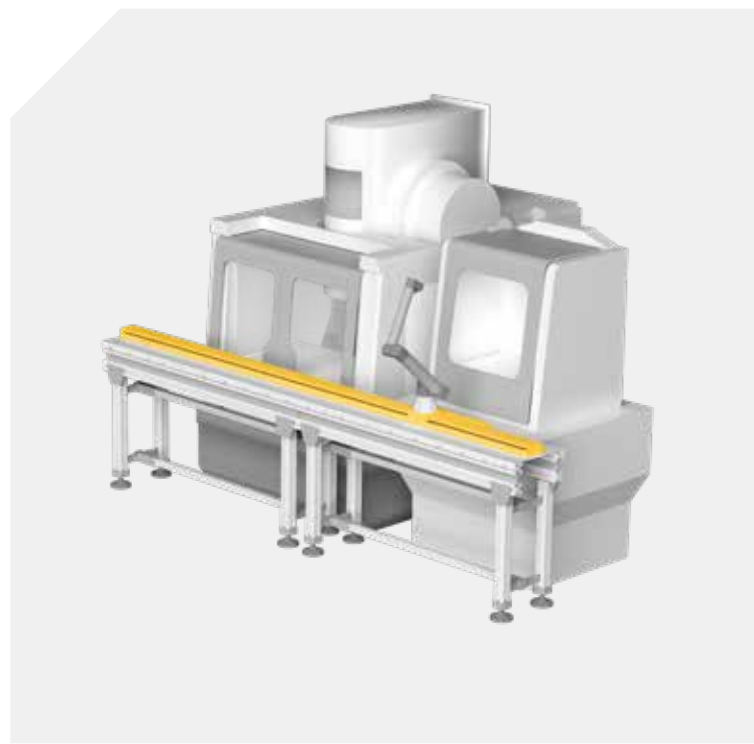

Solutions for vertical axes

Ewellix offers different telescopic pillar configurations to meet the demands of a range of robot applications. These telescopic pillars are very robust and stable, with built in drive system for easy integration.

TLT

- Telescopic design using two motors to achieve a high stroke with low retracted height
- Fast speed up to 80 mm/s at 1500 N push load
- Very quiet operation
- Mechanical brake included
- Different screw and motor options

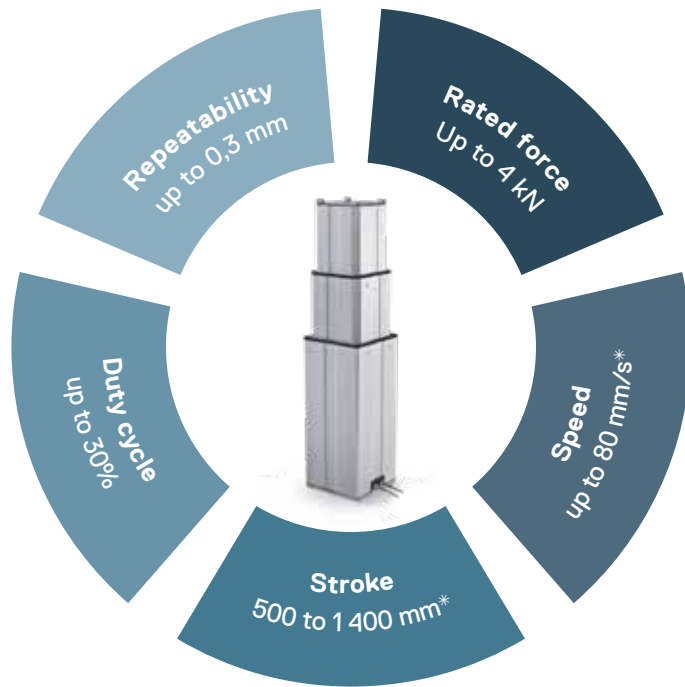

CPMT

Available on request

- Telescopic design using a double screw drive train to achieve a high stroke with low retracted height
- Higher duty cycle and lifetime compared to TLT
- Single motor design
- Push and pull load

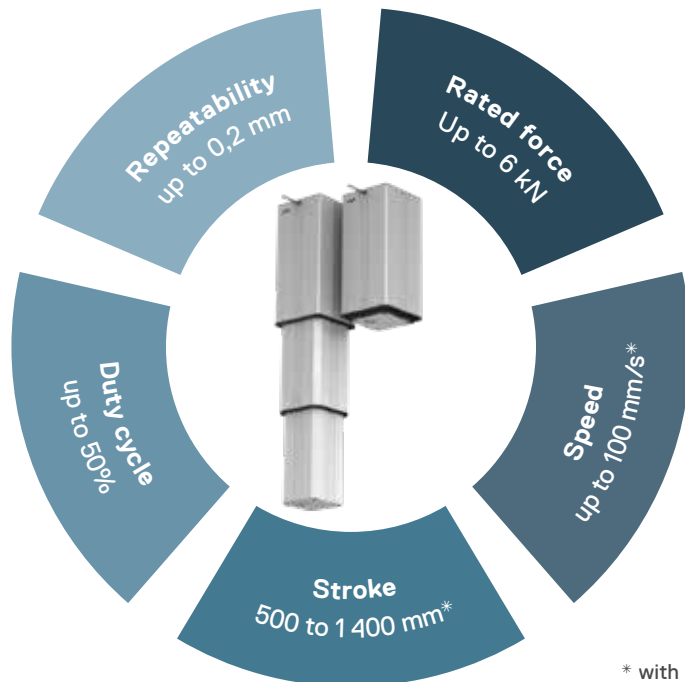

* with customization

CPSM





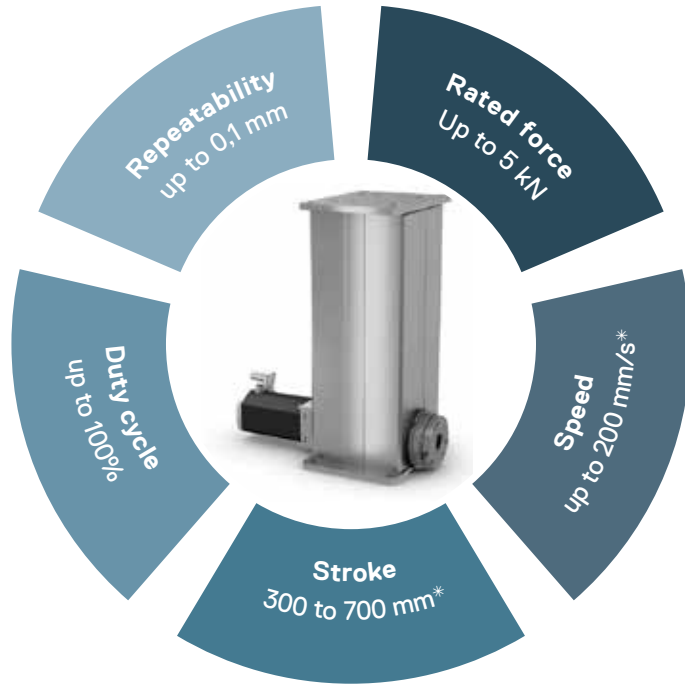







Available on request

- Servo pillar with full motor flexibility
- Can be provided with external brushless DC or servo motor, or interface for any third party motor
- Very high speeds over 200 mm/s
- Highest duty cycle and lifetime
- Push and pull load



* with customization

Key benefits for collaborative robots

 <p>TLT</p>	<p>Main application Palletizing</p> <p>Stroke/Speed High stroke</p> <p>Duty cycle Low</p>	<p>Push/pull force Push</p> <p>Positioning precision 0,3 mm</p> <p>Brake Internal</p>	  
 <p>CPMT</p>	<p>Main application Ceiling mounting and palletizing</p> <p>Stroke/Speed High stroke</p> <p>Duty cycle Medium</p>	<p>Push/pull force Push and pull</p> <p>Positioning precision 0,2 mm</p> <p>Brake Internal</p>	  
 <p>CPSM</p>	<p>Main application Pick and place</p> <p>Stroke/Speed High speed</p> <p>Duty cycle High</p>	<p>Push/pull force Push and pull</p> <p>Positioning precision 0,1 mm</p> <p>Brake External</p>	  

Solutions for horizontal axes

Ewellix offers different linear module configurations to meet the demands of a range of horizontal cobot positioning applications.

CLSM-150-B

Features

- Ball screw drive train (belt drive train on request)
- Four cover option for different protection levels
- High level of positioning precision and repeatability
- Inline and parallel gear boxes
- Customized motor adapter plate to fit any motor
- Stroke up to 1,8 m (longer strokes available on request)
- Speed up to 1,2 m/s (higher speed on request)

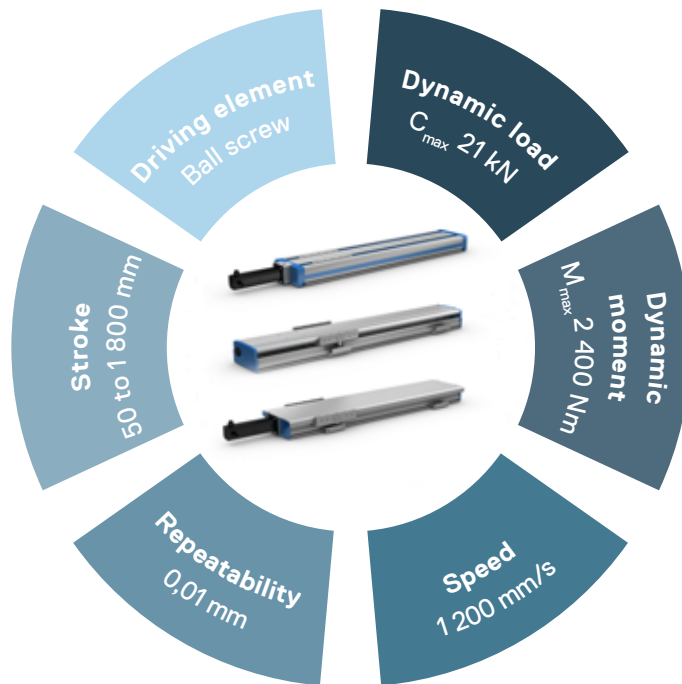

Benefits

- High movable loads in operation
- Long life in operation
- Easy maintenance by one-point lubrication option from both carriage sides
- Precise alignment and secure fastening of the attachments



Customized solutions

Ewellix offers a wide range of possible customizations to satisfy different application needs.

From basic modifications like custom attachments or painting to complete customized solution, Ewellix can offer tailor made systems to empower cobots users in getting most benefits for their applications.

In this customization example, we have realized a multi-axes system to move independently 2 robots on both horizontal and vertical axes, dramatically enlarging the operating range while keeping a very compact footprint.

Features

- Rack and pinion drivetrain
- Independent movement
- Stroke up to 6m
- Multiple carriages
- Custom robot mounting plates



Integrated solutions for Universal Robots

Complete plug & play solutions, UR+ certified, are available for cobots from Universal Robots. The LIFTKIT and SLIDEKIT provide a ready to install solution to easily add a vertical or horizontal axis to Universal Robots.

The kits include all required hardware, controllers and interfaces to the Universal Robots system. Also included is a URCaps software to directly control the additional axis from within the UR programming environment. No engineering resources needed! Ready to run in 30 minutes.

www.universal-robots.com/plus/accessories/liftkit/

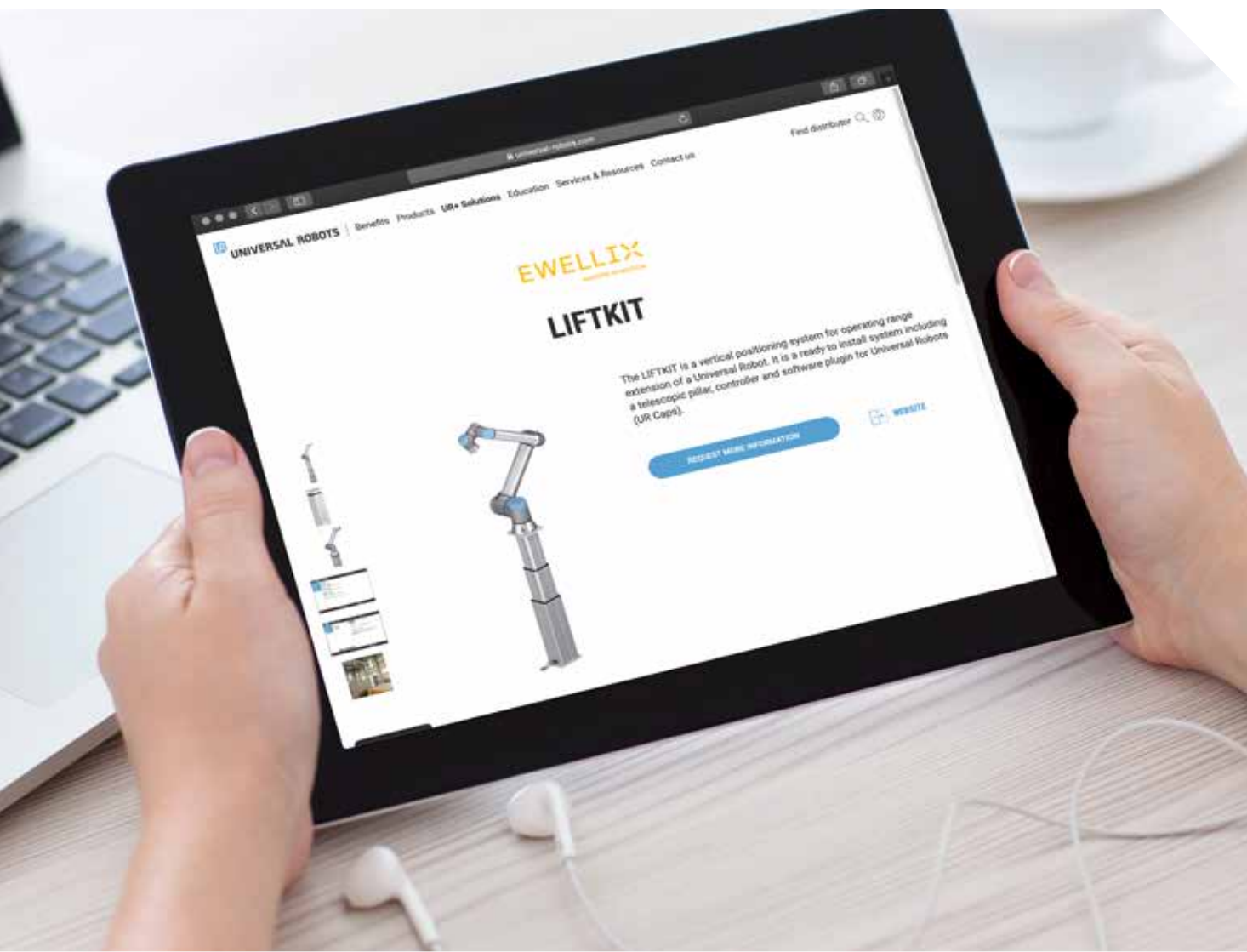



Linear axis for collaborative robots LIFTKIT

Operating range extension

- Vertical lifting of the cobot by up to 900 mm (1.400 mm on request) with compact retracted height
- Robust pillar design for industrial use, vibration free motion and virtually maintenance free

Plug-and-play solution

- Hardware interface compatible with UR3, UR5, UR10 and UR16 robots
- Universal Robots+ certified product
- Software control integrated with UR controller (URCaps) for easy motion programming
- Basic control option with digital I/O for all cobot manufacturers

Cost savings and higher productivity

Cobots combined with Ewellix LIFTKIT provide a cost-effective solution to upgrade an existing assembly shop, moving from a manual handled to a fully automatized line.



Technical data

	Unit	LIFTKIT-UR-601	LIFTKIT-00-601
Pillar type	-	TLT	TLT
Mechanical			
Push load	N	1 500	1 500
Pull load	N	0	0
Speed	mm/s	80	80
Stroke	mm	500 – 900	500 – 900
Retracted length (software controlled)	mm	Stroke/2 + 275	Stroke/2 + 275
Height of attachment plates	mm	2x15	1x15
Cross section	mm	163x163	163x163
Type of protection	IP	40	40
Ambient temperature	°C	+10 to +40	+10 to +40
Robots compatibility	-	UR3, UR5, UR10, UR16, e-Series	Any robot
Cable management	-	Threads on pillar and interface plate to attach cable management	Threads on pillar to attach cable management
Electrical			
Voltage/Current	V/A	120 AC / 6.5 A 230 AC / 3,3 A 24 DC / 10 A	120 AC / 6.5 A 230 AC / 3,3 A 24 DC / 10 A
Emergency stop	-	Connection to UR safety I/O	Connection to robot safety I/O
Communication			
Control interface	-	URCaps plugin compatible with CB3.1 / Polyscope 3.6 or higher	Digital I/O control, RS232 interface for external software control (no software provided)
Positioning, repeatability	mm	± 1	± 1
Accessible positions	-	any	2 memory positions programmable
Feedback	-	Position feedback via URCaps	Position feedback for memory positions via output signal
Soft start and stop	-	Implemented for smooth operation	Implemented for smooth operation
Software control	-	URcap	RS232 interface for external software control (no control software provided)

Dimensional drawing

TLT telescopic pillar

Robot attachment plate

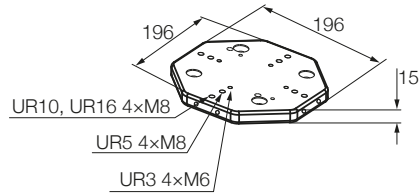

TLT Pillar

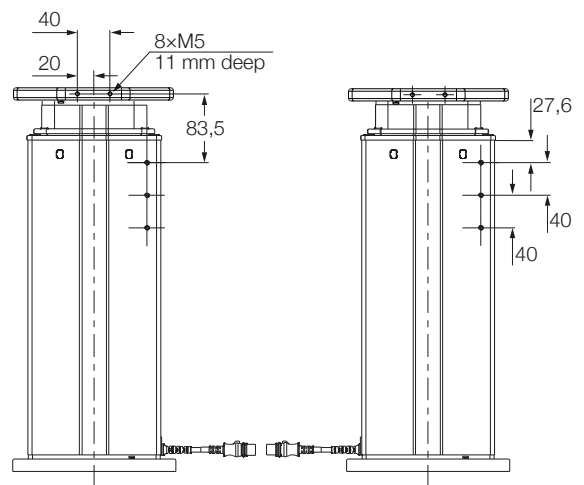
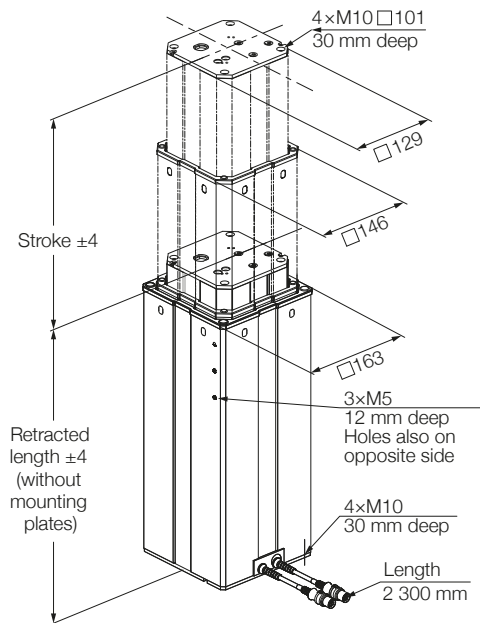

Bottom fixation plate

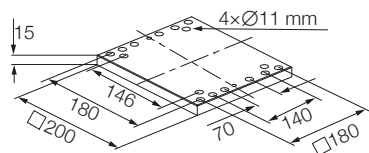

Control unit

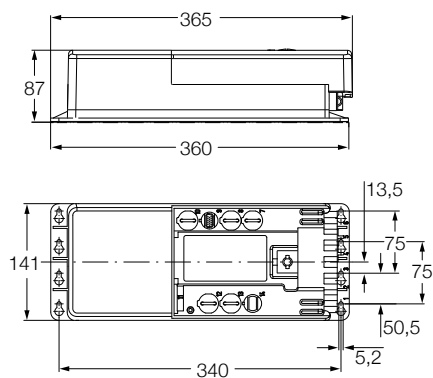

Cable management

Threads for cable management attachments

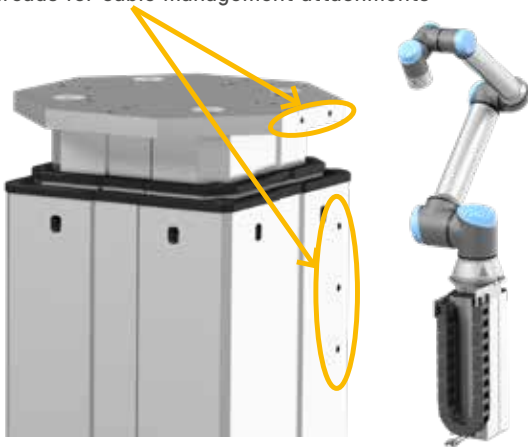

Connection diagram

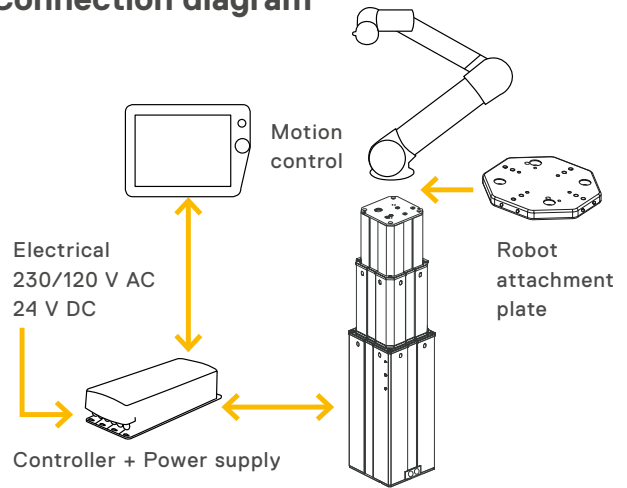

Example of LIFTKIT-00 interface board to robot PLC (not included)

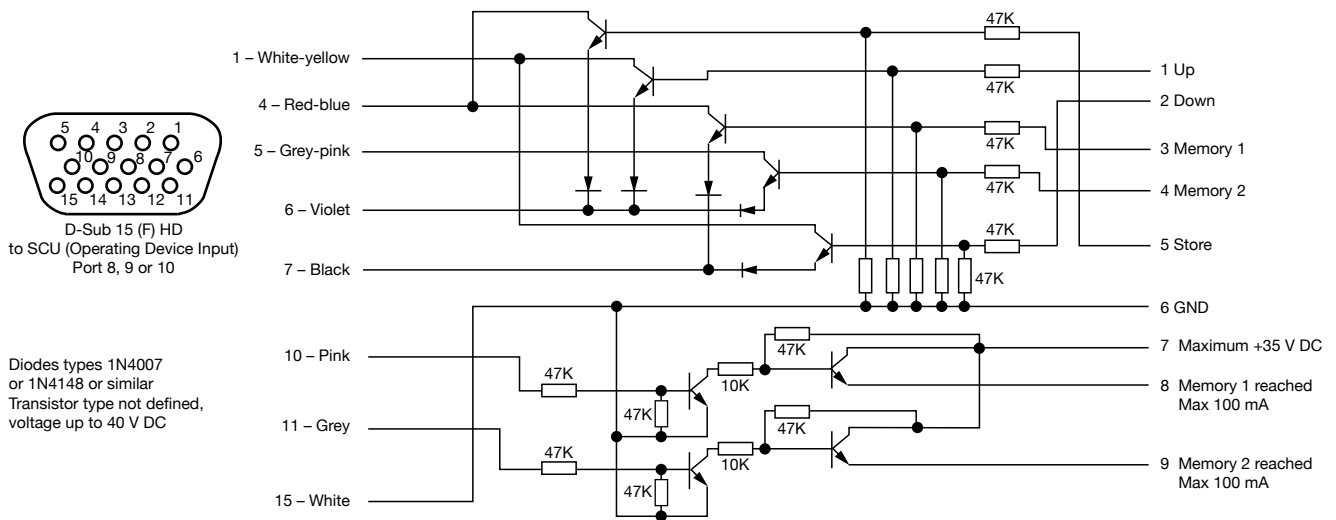

LIFTKIT contains

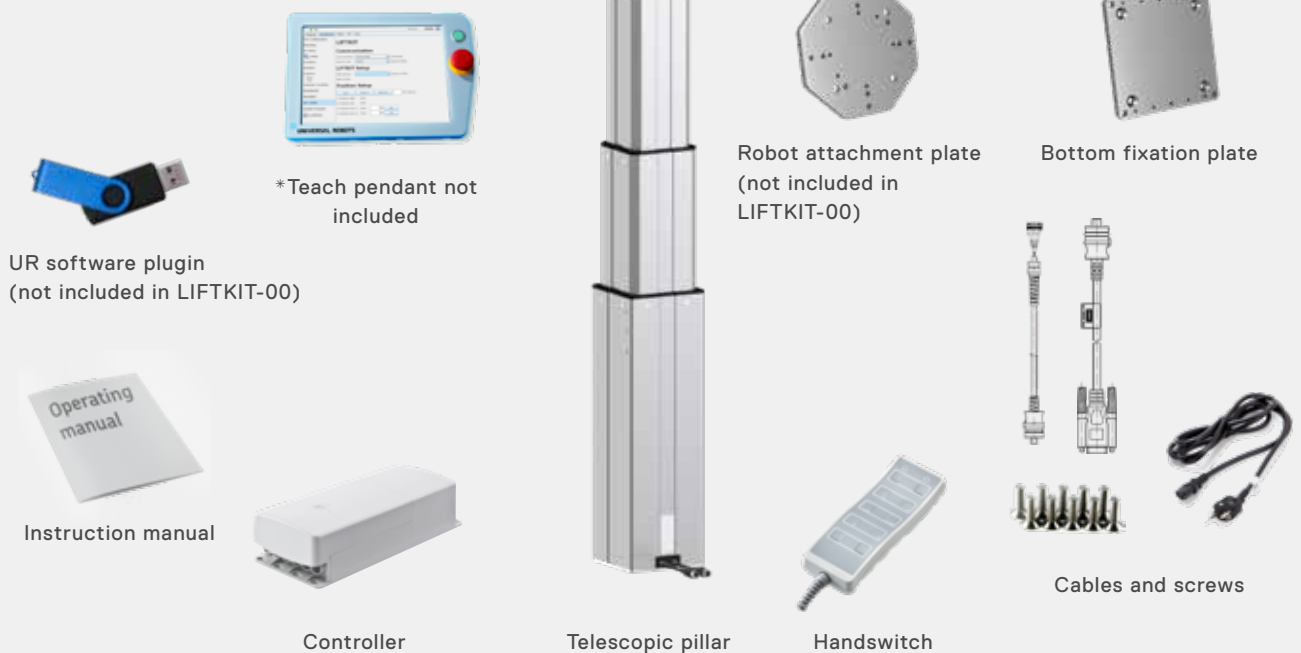

Software functionality

The URCaps software for the LIFTKIT allows easy positioning access directly within the UR Polyscope environment.

Setup

In the installation tab, the user can manually move the linear axis in both directions and define multiple user specific positions, that are accessible in programming mode.

Motion programming

Within the UR motion program, the LIFTKIT axis is easily integrated through a URCaps command module. Simply insert this element from the structure tab at the desired position of the program. Additionally, reading and setting positions is possible through a script function.

Safety elements

The LIFTKIT has a range of safety elements built in to allow its integration into a robot application.

Software updates

To download the latest software update please check on ewellix.com/support/library/software-updates.

NOTE:

The LIFTKIT is not a functional safety system compliant with EN ISO 13489-1 or IEC 62061. To integrate the LIFTKIT into a functional safety chain, external safety devices have to be integrated into the overall system.



LIFTKIT software functionality

Ordering key



Robot	_____	
00	Any robot (no software, no robot interface plate)	
UR	Universal Robots	
Stroke*	_____	
500	mm	
600	mm	
700	mm	
800	mm	
900	mm	
Electrical options	_____	
00	24 V DC	
11	120 V AC / US cable	
22	230 V AC / EU cable	
23	230 V AC / CN cable	
24	230 V AC / UK cable	
25	230 V AC / CH cable	
Pillar type	_____	
601	TLT	

* longer stroke up to 1 400 mm available on request

Linear axis for collaborative robots SLIDEKIT

Operating range extension

By adding a linear module as a dynamic base for the robot, it is possible to extend the handling operating area of the robot, increasing the productivity of a series of machines working in the same production flow.

Plug-and-play solution

The SLIDEKIT provides quick and fast installation, by having a standardized mechanical, electrical and software interface with Universal Robots.

In few steps, the system is ready to be used and simply programmed in operation.

Cost savings and higher productivity

UR cobots combined with the SLIDEKIT linear module provide a cost-effective solution to upgrade an existing assembly shop, moving from a manual handled to a fully automatized line.

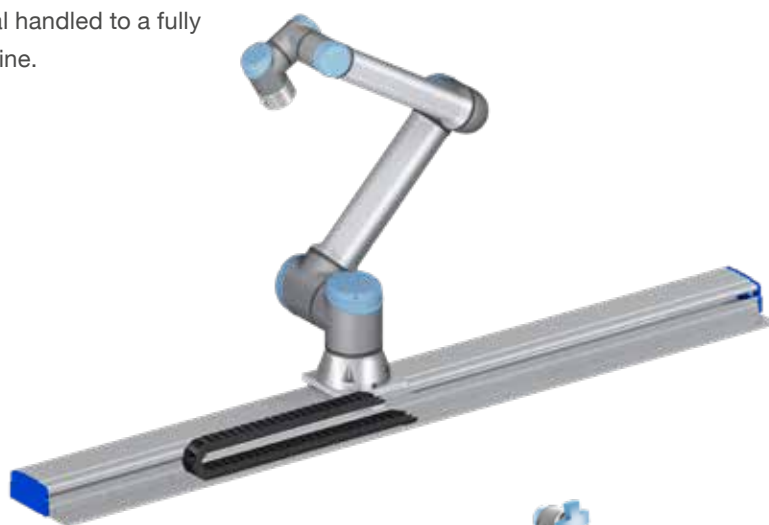

Technical data

	Unit	SLIDEKIT-UR
Performance data		
Max. dynamic load	N	21 000
Max. dynamic moments	Nm	2 400
Stroke	mm	100...1 800
Max. speed	mm/s	1 200
Duty cycle	%	100
Screw lead	mm	05 or 10 or 20
Repeatability	mm	0,01
Ambient temperature	°C	0 to +50
Max. humidity	%	95
Electrical data		
Power input	V AC / A	120 to 240 / 6,5 to 3,3
Software functionality		
Programmable positions	-	10
Access to position via UR Caps	-	yes
Speed adjustable	-	yes
Universal Robots controller compatibility	-	CB 3.1 / Polyscope 3.6 or higher

Dimensional drawing

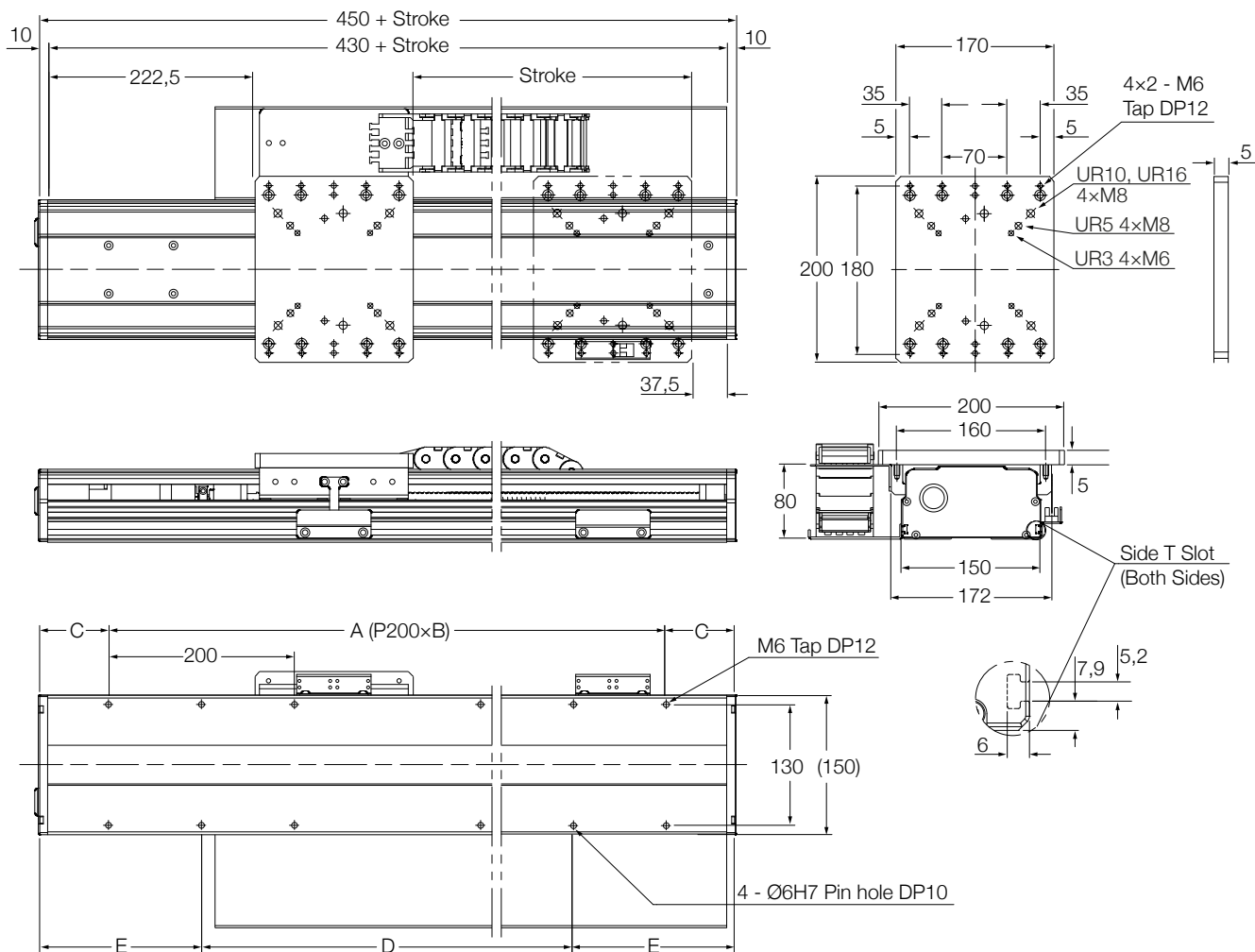

	Stroke mm	A	B	C	D	E
1	100	400	2	75	200	175
2	200	600	3	25	400	125
3	300	600	3	75	400	175
4	400	800	4	25	600	125
5	500	800	4	75	600	175
6	600	1 000	5	25	800	125
7	700	1 000	5	75	800	175
8	800	1 200	6	25	1 000	125
9	900	1 200	6	75	1 000	175
10	1 000	1 400	7	25	1 200	125
11	1 100	1 400	7	75	1 200	175
12	1 200	1 600	8	25	1 400	125
13	1 300	1 600	8	75	1 400	175
14	1 400	1 800	9	25	1 600	125
15	1 500	1 800	9	75	1 600	175
16	1 600	2 000	10	25	1 800	125
17	1 700	2 000	10	75	1 800	175
18	1 800	2 200	11	25	2 000	125

Connection diagram

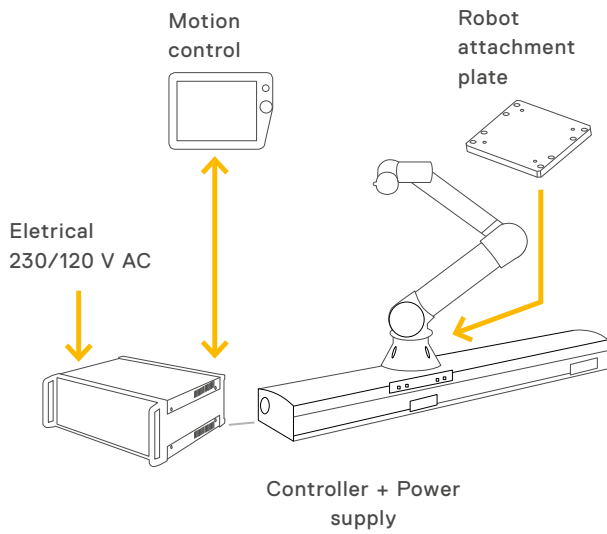

Dimensional drawing

Control unit

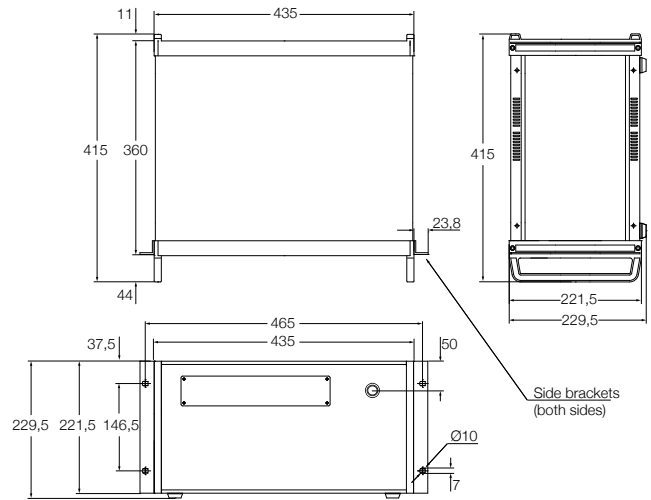

NOTE:

Side brackets for rack mounting are provided with the control box but are not pre-mounted

SLIDEKIT contains

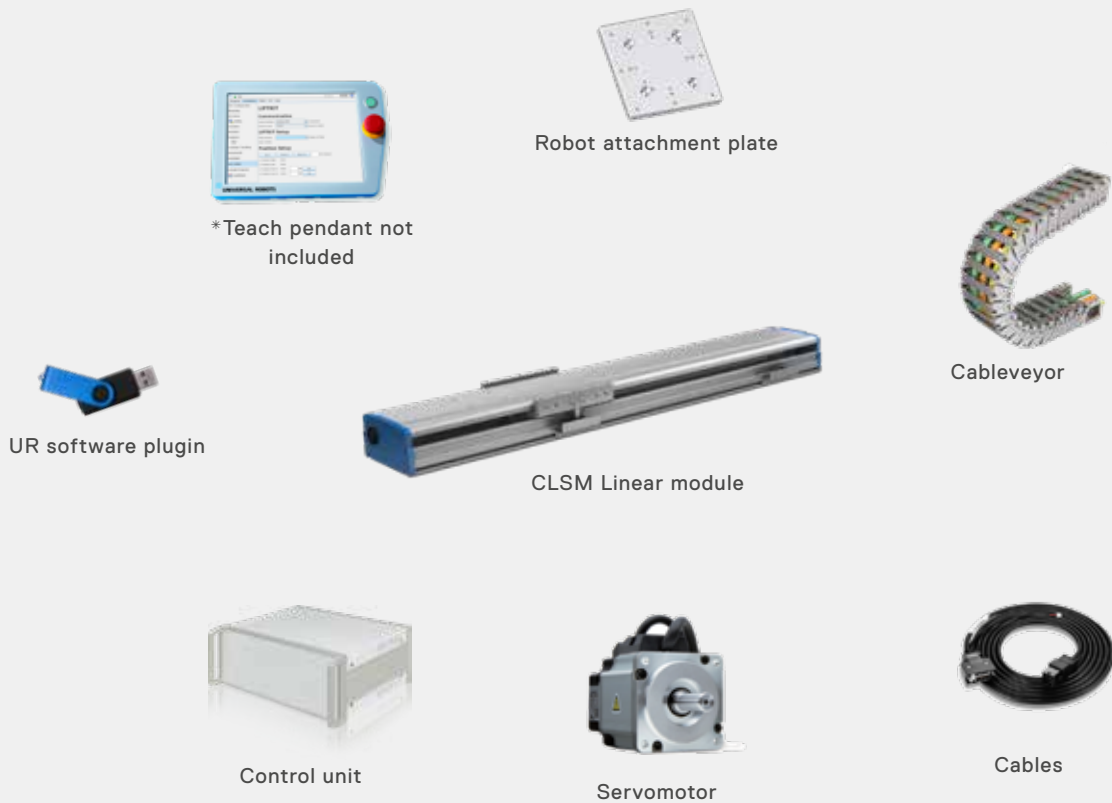

Software functionality

The URCaps software for the SLIDEKIT allows easy positioning access directly within the UR Polyscope environment.

Setup

In the installation tab, the user can manually move the linear axis in both directions and define multiple user specific positions, that are accessible in programming mode.

Motion programming

Within the UR motion program, the SLIDEKIT axis is easily integrated through a URCaps command module. Simply insert this element from the structure tab at the desired position of the program. Additionally, reading and setting positions is possible through a script function.

Safety elements

The SLIDEKIT has a range of safety elements built in to allow its integration into a robot application.

Software updates

To download the latest software update please check on ewellix.com/support/library/software-updates.



SLIDEKIT software functionality

NOTE:

The SLIDEKIT is not a functional safety system compliant with EN ISO 13489-1 or IEC 62061. To integrate the SLIDEKIT into a functional safety chain, external safety devices have to be integrated into the overall system.

Ordering key

Robot
UR Universal Robots

Module options
B Ball screw

05 Lead
10 Lead
20 Lead

A Cover Aluminum
P Cover PU-Strip
S Cover Steel

Stroke
100 ... 1 800 mm

Electrical options
11 120 VAC / US cable
22 230 VAC / EU cable
23 230 VAC / CN cable
24 230 VAC / UK cable
25 230 VAC / CH cable

Accessories options
0 No limit switches
S Limit switches

0 No cableveyor
C Cableveyor

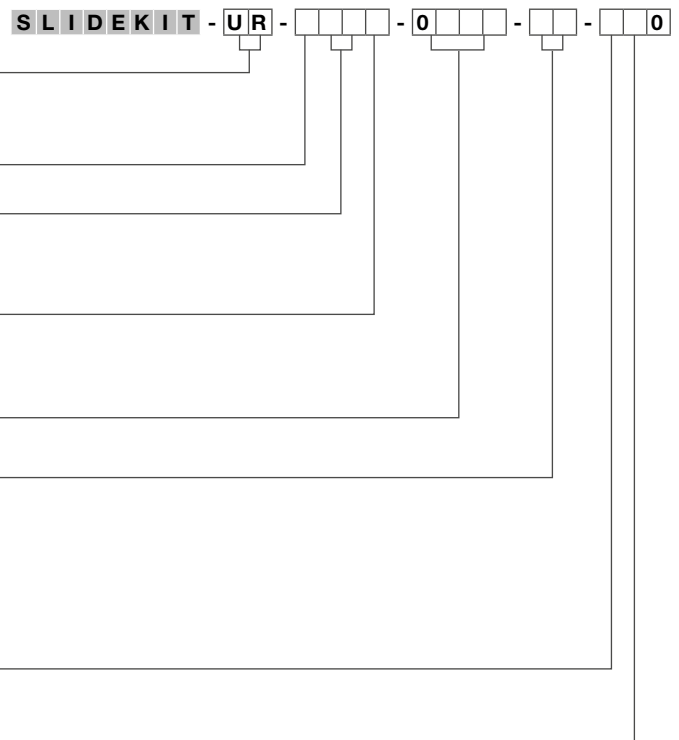

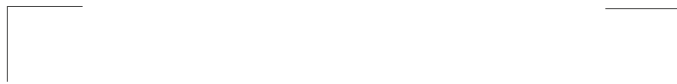

ewellix.com

© Ewellix

All contents of this publication are the property of Ewellix, and may not be reproduced or given to third parties (even extracts) without permission. Although great care has been taken in the production of this catalog, Ewellix does not take any responsibility for damage or other loss resulting from omissions or typographical errors. The photo may differ slightly in appearance from the actual product. Due to continuous improvements being made in our products, the product's appearance and specifications are subject to change without notice.

PUB EL-02002/1-EN-January 2020

Certain image(s) used under license from Shutterstock.com.
SKF and SKF logo are trademarks of the SKF Group