

# STANDARD RAINWATERHEAD BOOKLET

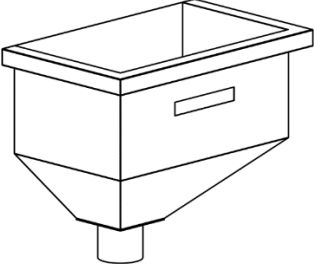

<p><b>Standard Tapered Bottom</b></p>  <p>1</p>	<p><b>Tapered</b></p>  <p>2</p>	<p><b>New Style</b></p>  <p>3</p>
<p><b>Conical</b></p>  <p>4</p>	<p><b>Corner Conical</b></p>  <p>5</p>	<p><b>Ned Kelly</b></p>  <p>6</p>
<p><b>Square</b></p>  <p>7</p>	<p><b>Low Profile</b></p>  <p>8</p>	<p><b>U-Shape</b></p>  <p>9</p>
<p><b>Half Cylindrical</b></p>  <p>10</p>	<p><b>Half Round</b></p>  <p>11</p>	<p><b>Quarter Round</b></p>  <p>12</p>

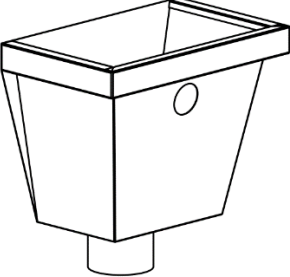
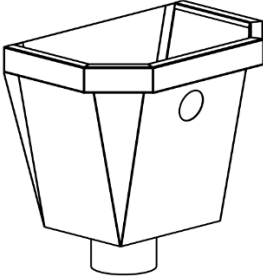
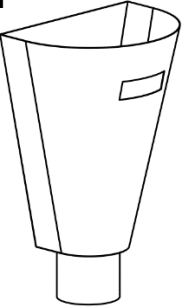
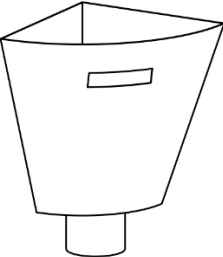
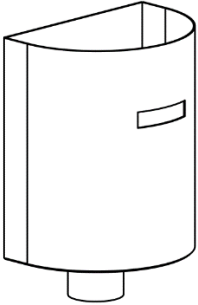
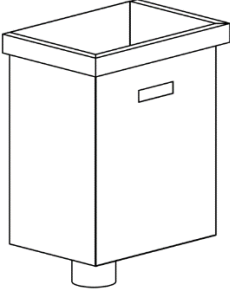
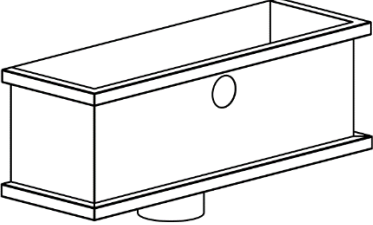
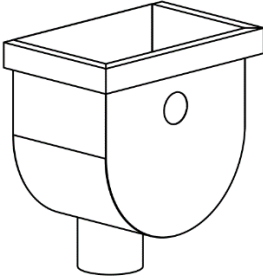
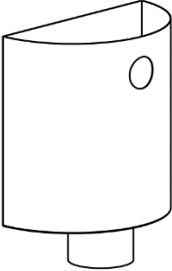
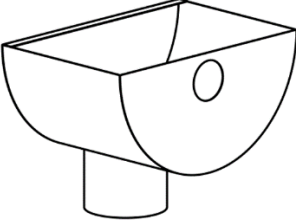
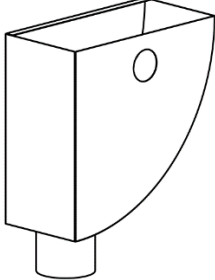
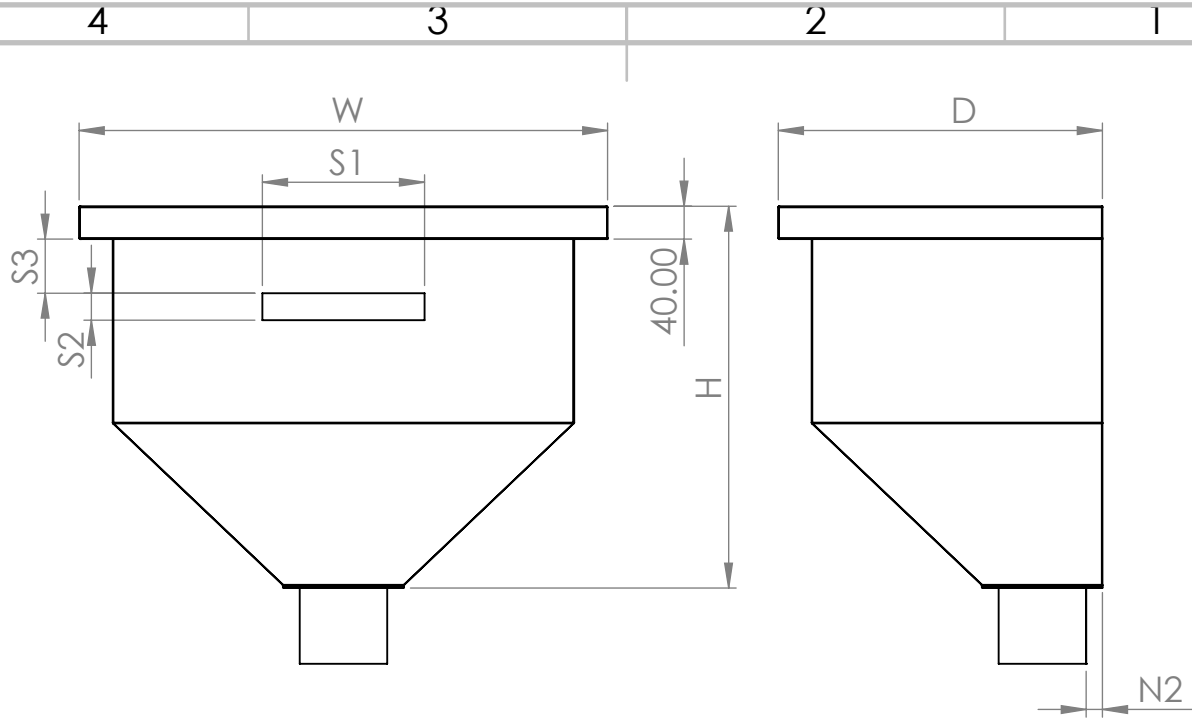

FRONT VIEW

SIDE VIEW

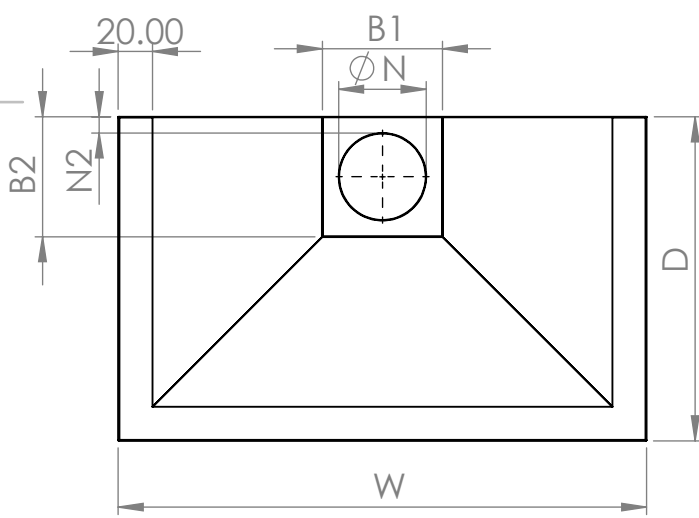

TOP VIEW

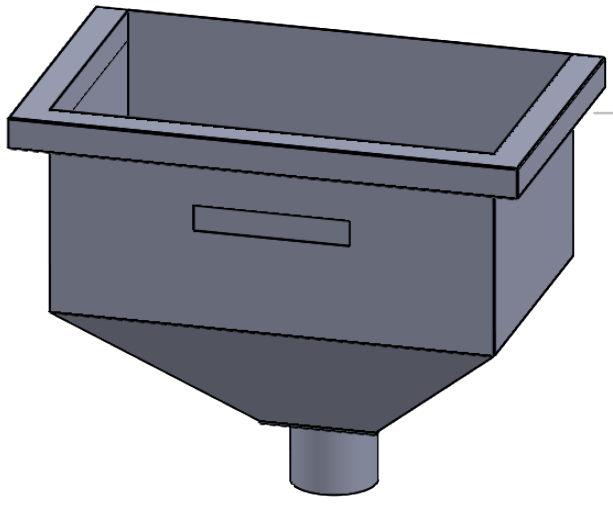

ISOMETRIC VIEW

	B1	B2	H	W	D	Material Availability ( Please tick required):
<b>Small</b>	120	120	250	300	205	<ul style="list-style-type: none"> <li>• 1.20BMT Aluminium - TIG welded</li> <li>• 1.20BMT Aluminium - Powdercoated</li> <li>• 0.70BMT Galvanized - Soldered</li> <li>• 0.55BMT Stainless Steel - Soldered</li> <li>• 1.20BMT Stainless Steel - TIG welded</li> <li>• 0.55BMT Colorbond/Plain - Riveted</li> <li>• 0.70BMT Zinc Mill Finish - Soldered</li> <li>• 0.70BMT Copper - Soldered</li> </ul>
<b>Medium</b>	120	120	350	400	255	
<b>Large</b>	120	120	450	500	305	
<b>Custom</b>						

\*NOTE - Custom sizing would incur additional charges\*

PLEASE INDICATE NOZZLE/OVERFLOW/OTHER DIMENSIONS IN ABOVE DRAWINGS



All dimensions are in millimetres

TITLE

Standard Tapered Bottom

Page

1

WEBSITE: www.kfcroofing.com.au

PH: 02 9810 0915

FILE PATH Z:\Development files\Rainwaterheads Booklet\Standard\Tapered Bottom\

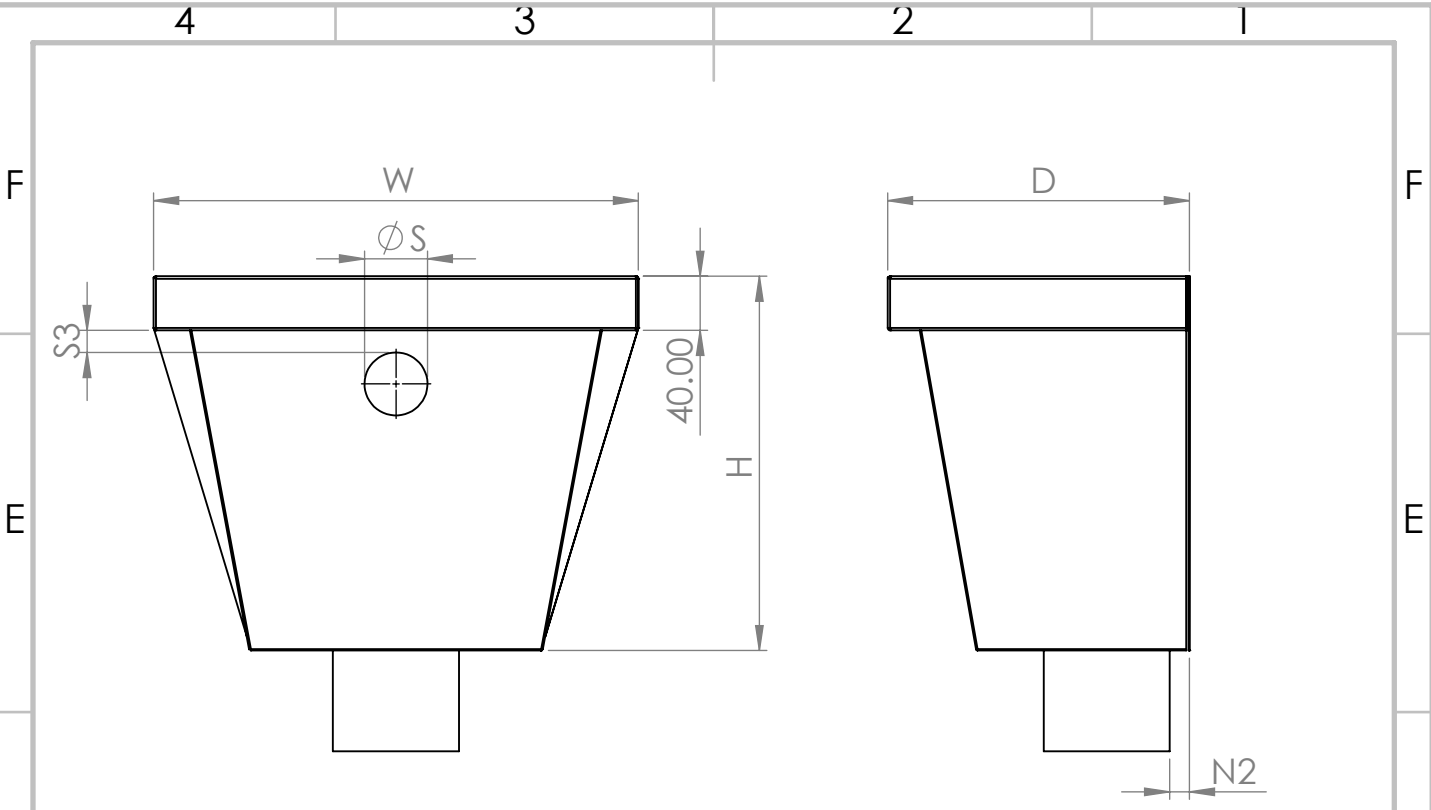

FRONT VIEW

SIDE VIEW

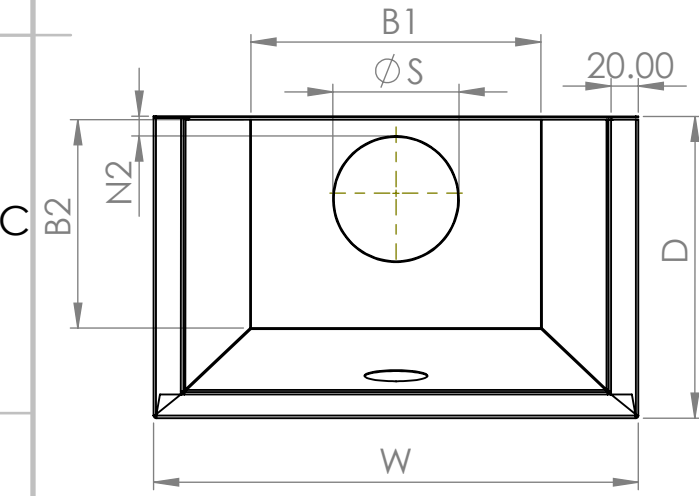

PLAN VIEW

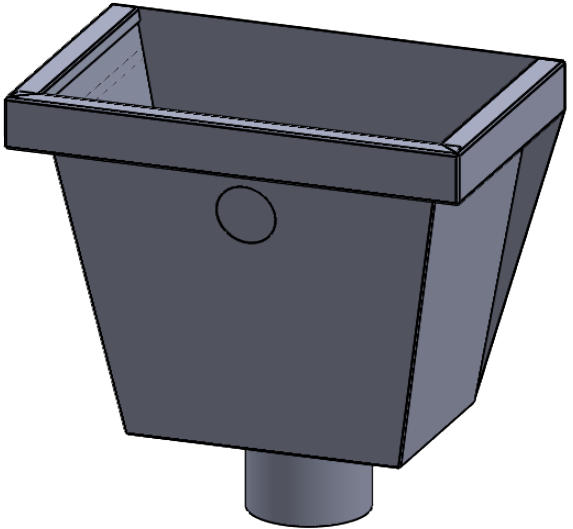

ISOMETRIC VIEW

	B1	B2	H	W	D	Material Availability ( Please tick required):
<b>Small</b>	200	150	250	340	225	<ul style="list-style-type: none"> <li>• 1.20BMT Aluminium - TIG welded</li> <li>• 1.20BMT Aluminium - Powdercoated</li> <li>• 0.70BMT Copper - Soldered</li> <li>• 0.70BMT Galvanized - Soldered</li> <li>• 0.55BMT Stainless Steel - Soldered</li> <li>• 1.20BMT Stainless Steel - TIG welded</li> <li>• 0.70BMT Zinc Mill Finish - Soldered</li> <li>• 0.55BMT Colorbond/Plain - Riveted</li> </ul>
<b>Medium</b>	250	200	300	390	275	
<b>Large</b>	300	250	350	440	325	
<b>Custom</b>						

\*NOTE - Custom sizing would incur additional charges\*

PLEASE INDICATE NOZZLE/OVERFLOW/OTHER DIMENSIONS IN ABOVE DRAWINGS



All dimensions are in millimetres

TITLE

Tapered

Page

2

WEBSITE: www.kfcroofing.com.au

PH: 02 9810 0915

FILE PATH Z:\Development files\Rainwaterheads Booklet\Tapered\

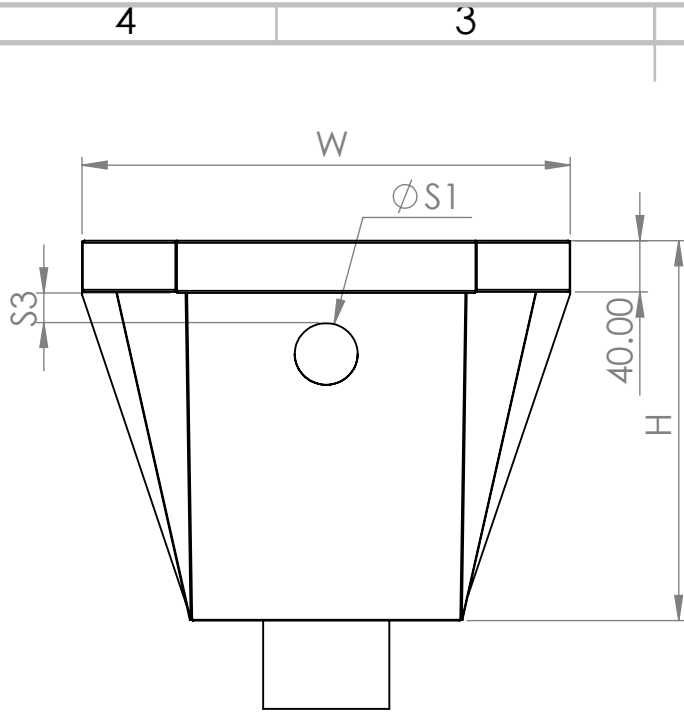

FRONT VIEW

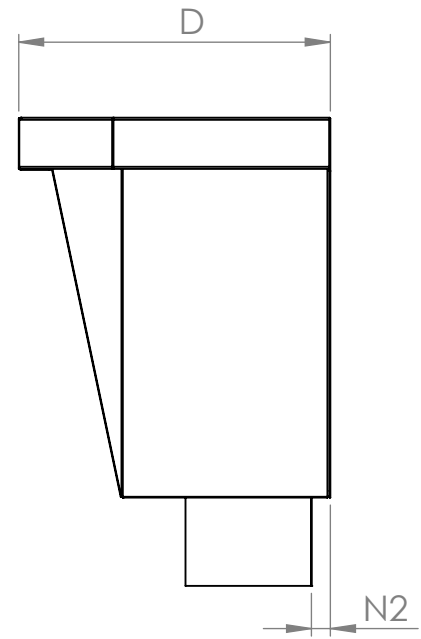

SIDE VIEW

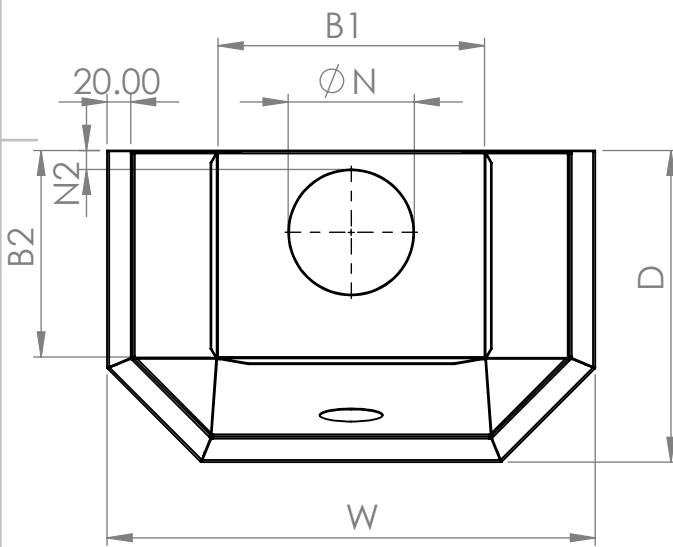

PLAN VIEW

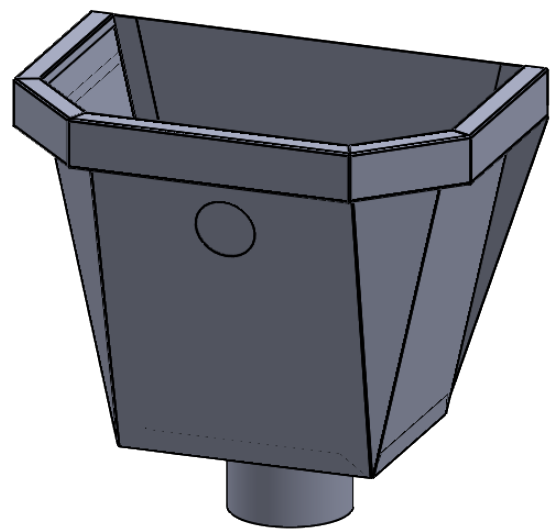

SIDE VIEW

	B1	B2	H	W	D	Material Availability ( Please tick required):
<b>Small</b>	-	-	-	-	-	<ul style="list-style-type: none"> <li>• 1.20BMT Aluminium - TIG welded</li> <li>• 1.20BMT Aluminium - Powdercoated</li> <li>• 0.70BMT Copper - Soldered</li> <li>• 0.70BMT Galvanized - Soldered</li> <li>• 0.55BMT Stainless Steel - Soldered</li> <li>• 1.20BMT Stainless Steel - TIG welded</li> <li>• 0.70BMT Zinc Mill Finish - Soldered</li> <li>• 0.55BMT Colorbond/Plain - Riveted</li> </ul>
<b>Medium</b>	220	170	300	390	250	
<b>Large</b>	-	-	-	-	-	
<b>Custom</b>						

\*NOTE - Custom sizing would incur additional charges\*

PLEASE INDICATE NOZZLE/OVERFLOW/OTHER DIMENSIONS IN ABOVE DRAWINGS



All dimensions are in millimetres

TITLE

New Style

Page

3

WEBSITE: www.kfcroofing.com.au

PH: 02 9810 0915

FILE PATH Z:\Development files\Rainwaterheads Booklet\New Style\

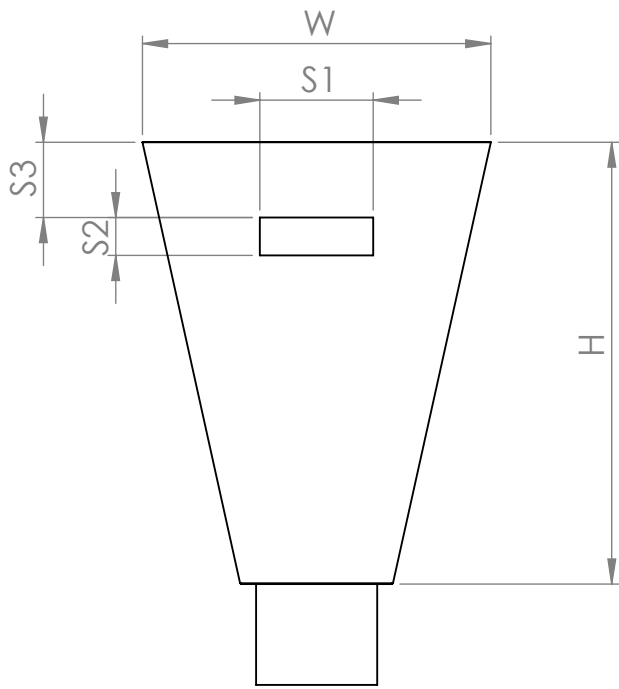

FRONT VIEW

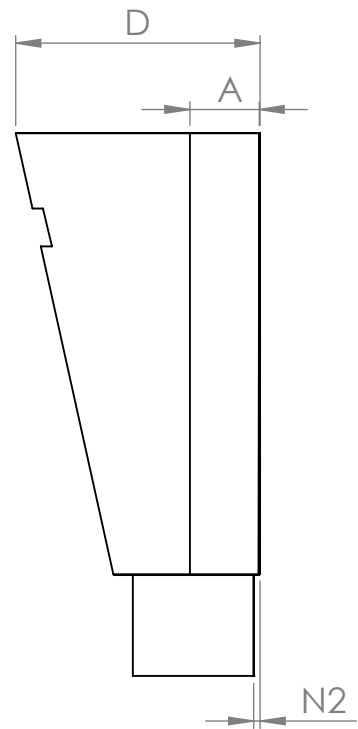

SIDE VIEW

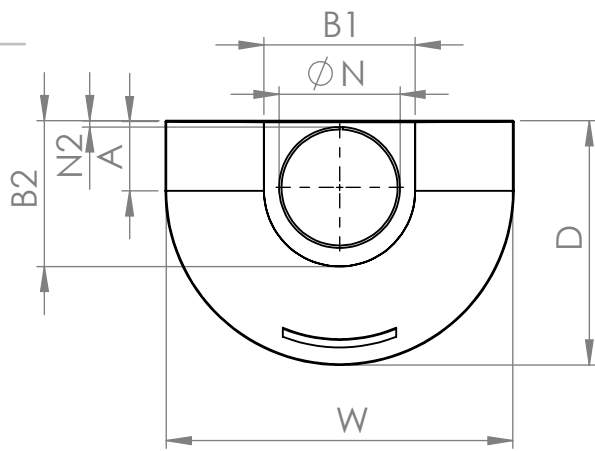

PLAN VIEW

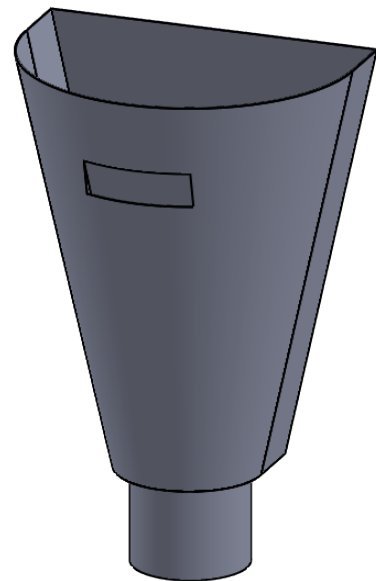

ISOMETRIC VIEW

	B1	B2	H	W	D	Material Availability ( Please tick required):
<b>Small</b>	120	120	400	300	350	<ul style="list-style-type: none"> <li>• 1.20BMT Aluminium - TIG welded</li> <li>• 1.20BMT Aluminium - Powdercoated</li> <li>• 0.70BMT Copper - Soldered</li> <li>• 0.70BMT Galvanized - Soldered</li> <li>• 0.55BMT Stainless Steel - Soldered</li> <li>• 0.70BMT Zinc Mill Finish - Soldered</li> <li>• 0.55BMT Colorbond/Plain - Riveted</li> </ul>
<b>Medium</b>	120	120	500	400	450	
<b>Large</b>	120	120	600	500	550	
<b>Custom</b>						

\*NOTE - Custom sizing would incur additional charges\*

PLEASE INDICATE NOZZLE/OVERFLOW/OTHER DIMENSIONS IN ABOVE DRAWINGS



All dimensions are in millimetres

TITLE

Conical

Page

4

WEBSITE: www.kfcroofing.com.au

PH: 02 9810 0915

FILE PATH Z:\Development files\Rainwaterheads Booklet\Conical\Standard\

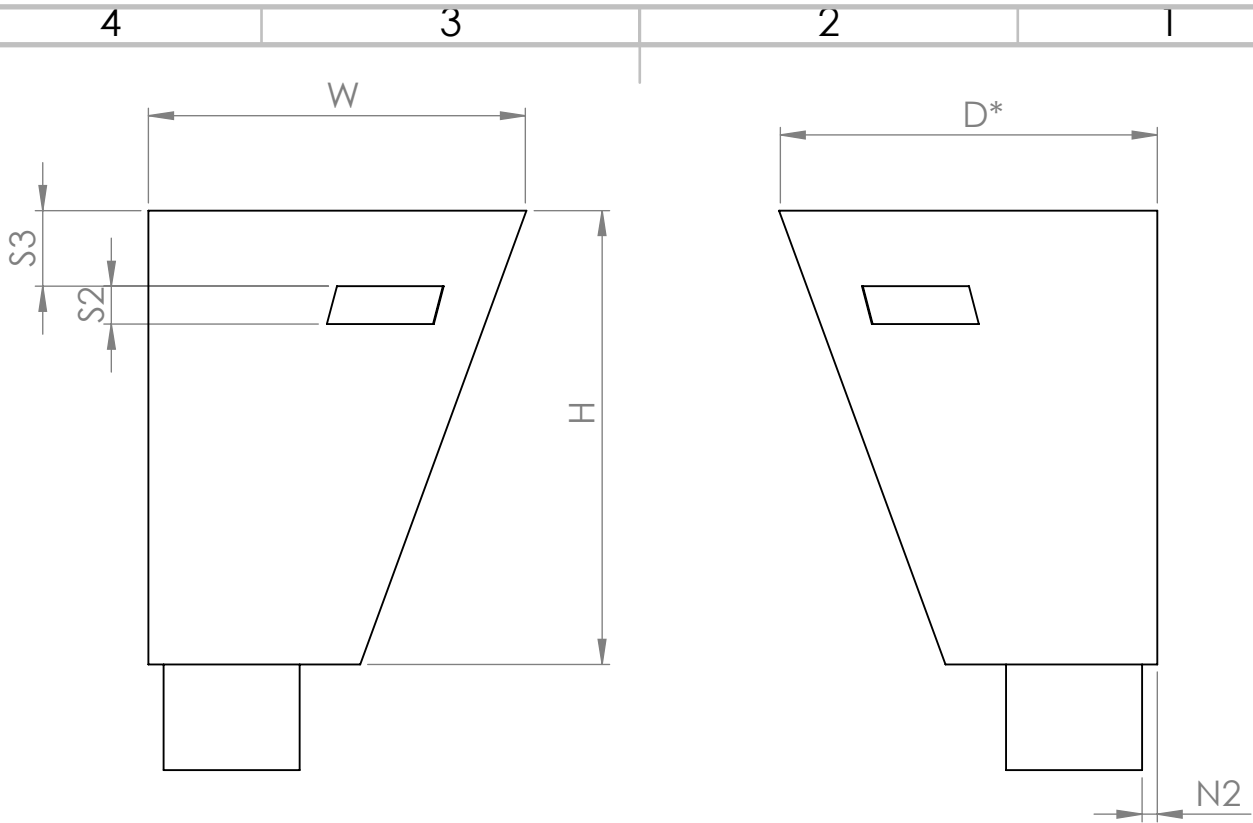

FRONT VIEW

SIDE VIEW

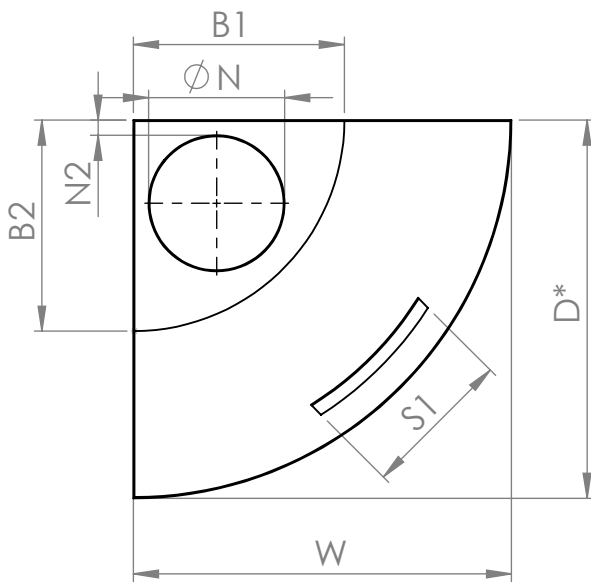

PLAN VIEW

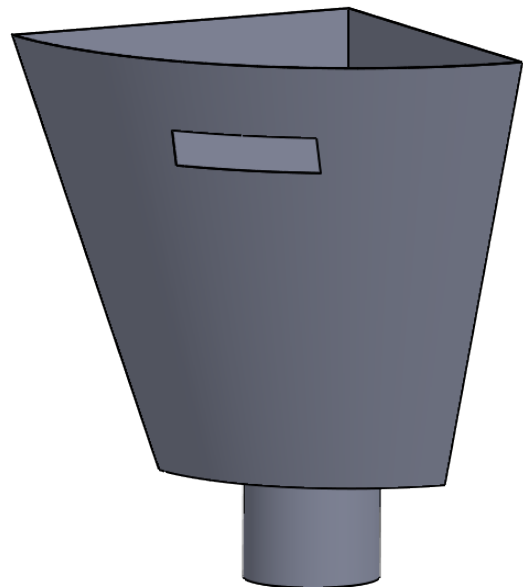

ISOMETRIC VIEW

**\*NOTE - Depth (D) is for reference purpose only and depends on Width(W) of RWH.\***

	B1	B2	H	W	D	Material Availability ( Please tick required):
<b>Small</b>	120	120	400	300	300	<ul style="list-style-type: none"> <li>• 1.20BMT Aluminium - TIG welded</li> <li>• 1.20BMT Aluminium - Powdercoated</li> <li>• 0.70BMT Copper - Soldered</li> <li>• 0.70BMT Galvanized - Soldered</li> <li>• 0.55BMT Stainless Steel - Soldered</li> <li>• 1.20BMT Stainless Steel - TIG welded</li> <li>• 0.70BMT Zinc Mill Finish - Soldered</li> <li>• 0.55BMT Colorbond/Plain - Riveted</li> </ul>
<b>Medium</b>	120	120	500	400	400	
<b>Large</b>	120	120	600	500	500	
<b>Custom</b>						

\*NOTE - Custom sizing would incur additional charges\*

**PLEASE INDICATE NOZZLE/OVERFLOW/OTHER DIMENSIONS IN ABOVE DRAWINGS**



All dimensions are in millimetres

TITLE

Corner Conical

Page

5

WEBSITE: www.kfcroofing.com.au

PH: 02 9810 0915

FILE PATH Z:\Development files\Rainwaterheads Booklet\Conical\Corner\

4

3

2

1

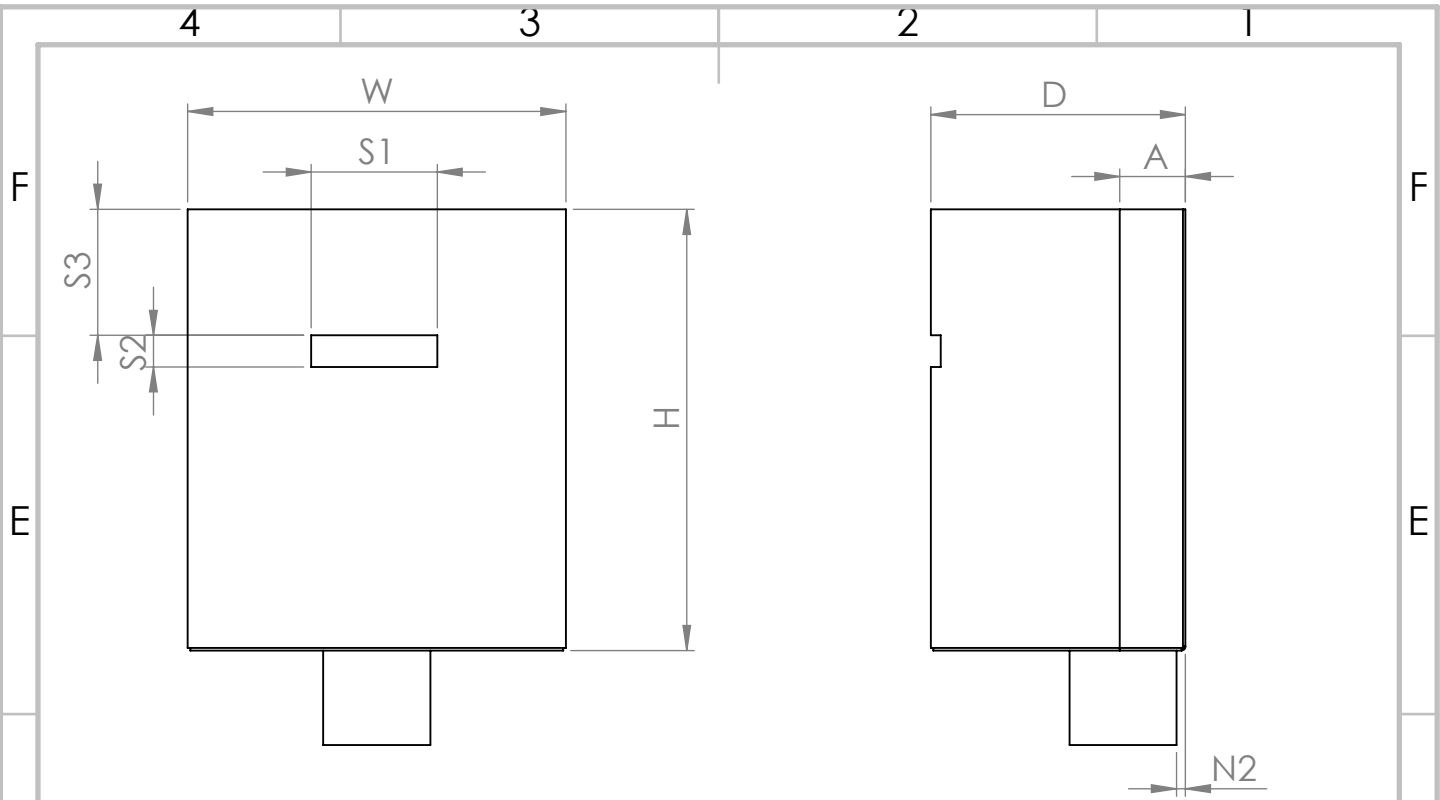

FRONT VIEW

SIDE VIEW

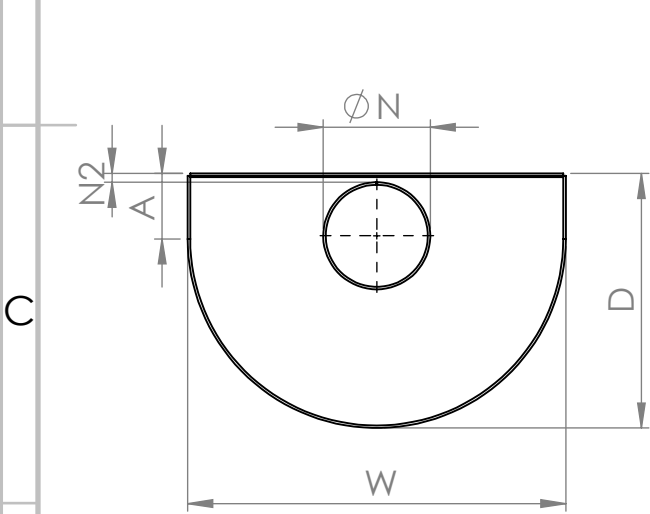

PLAN VIEW

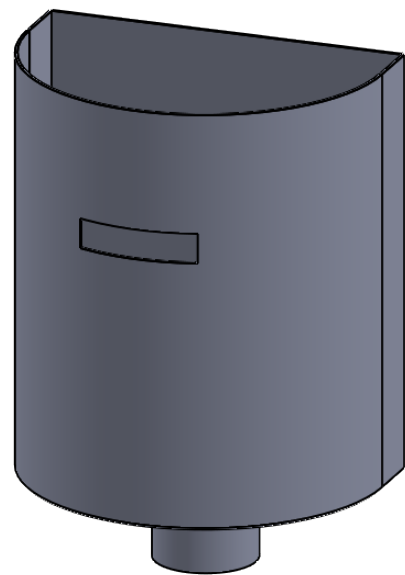

ISOMETRIC VIEW

	B1	B2	H	W	D	Material Availability ( Please tick required):
<b>Small</b>	-	-	300	250	200	<ul style="list-style-type: none"> <li>1.20BMT Aluminium - TIG welded</li> <li>1.20BMT Aluminium - Powdercoated</li> <li>0.70BMT Copper - Soldered</li> <li>0.70BMT Galvanized - Soldered</li> <li>0.55BMT Stainless Steel - Soldered</li> <li>1.20BMT Stainless Steel - TIG welded</li> <li>0.70BMT Zinc Mill Finish - Soldered</li> <li>0.55BMT Colorbond/Plain - Riveted</li> </ul>
<b>Medium</b>	-	-	400	350	300	
<b>Large</b>	-	-	500	450	400	
<b>Custom</b>						

\*NOTE - Custom sizing would incur additional charges\*

PLEASE INDICATE NOZZLE/OVERFLOW/OTHER DIMENSIONS IN ABOVE DRAWINGS



All dimensions are in millimetres

TITLE

Ned Kelly

Page

6

WEBSITE: www.kfcroofing.com.au

PH: 02 9810 0915

FILE PATH Z:\Development files\Rainwaterheads Booklet\Ned Kelly\



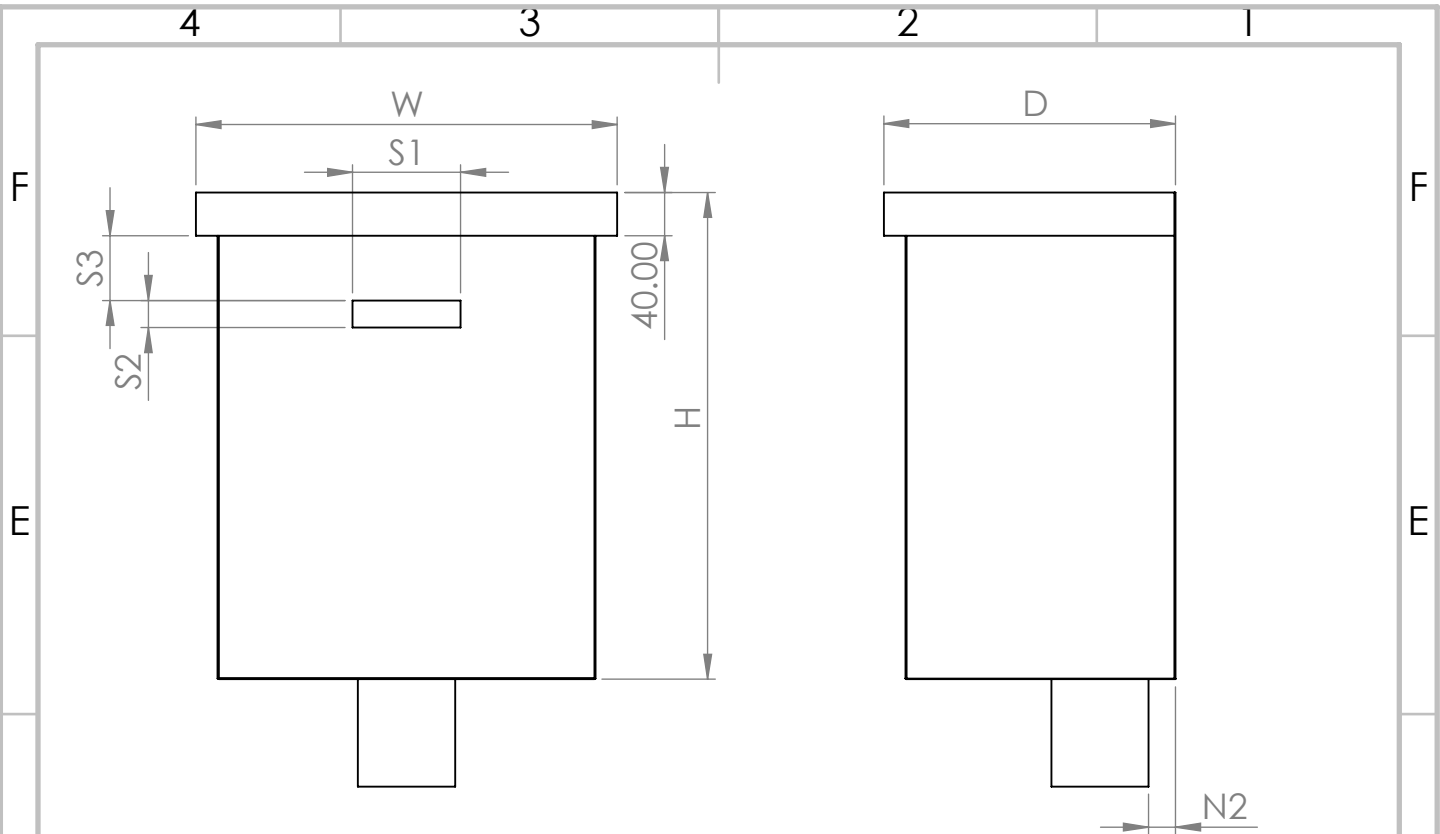

FRONT VIEW

SIDE VIEW

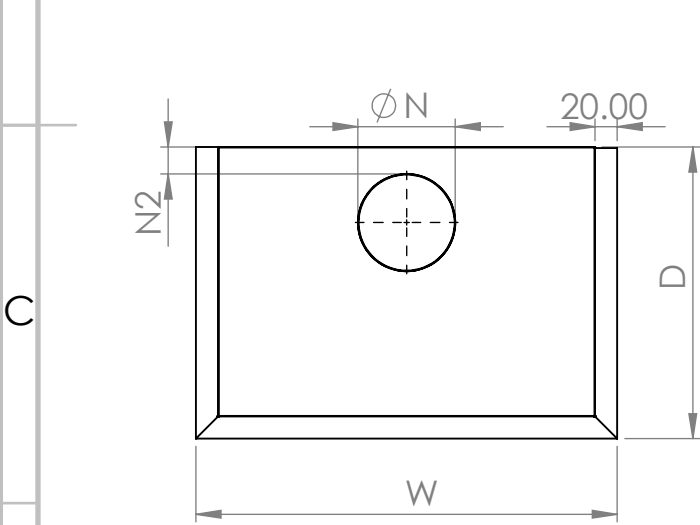

PLAN VIEW

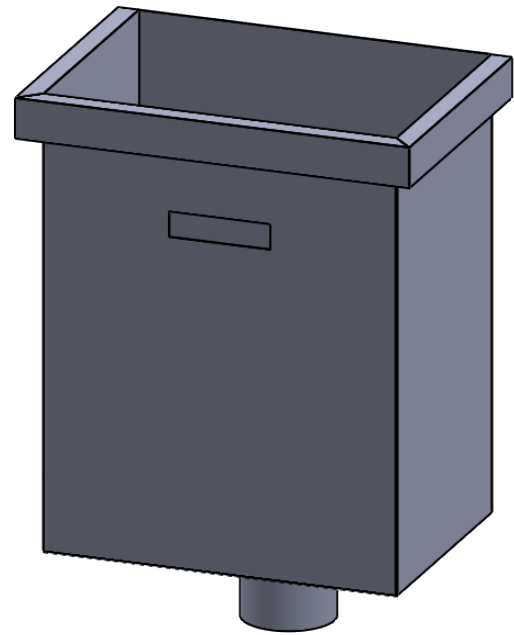

ISOMETRIC VIEW

	B1	B2	H	W	D	Material Availability ( Please tick required):
<b>Small</b>	-	-	300	300	250	<ul style="list-style-type: none"> <li>• 1.20BMT Aluminium - TIG welded</li> <li>• 1.20BMT Aluminium - Powdercoated</li> <li>• 0.70BMT Copper - Soldered</li> <li>• 0.70BMT Galvanized - Soldered</li> <li>• 0.55BMT Stainless Steel - Soldered</li> <li>• 1.20BMT Stainless Steel - TIG welded</li> <li>• 0.70BMT Zinc Mill Finish - Soldered</li> <li>• 0.55BMT Colorbond/Plain - Riveted</li> </ul>
<b>Medium</b>	-	-	400	400	300	
<b>Large</b>	-	-	500	500	350	
<b>Custom</b>						

\*NOTE - Custom sizing would incur additional charges\*

PLEASE INDICATE NOZZLE/OVERFLOW/OTHER DIMENSIONS IN ABOVE DRAWINGS

	All dimensions are in millimetres PH: 02 9810 0915 WEBSITE: www.kfcroofing.com.au	TITLE	Square Page <b>7</b>
		FILE PATH Z:\Development files\Rainwaterheads Booklet\Square\	

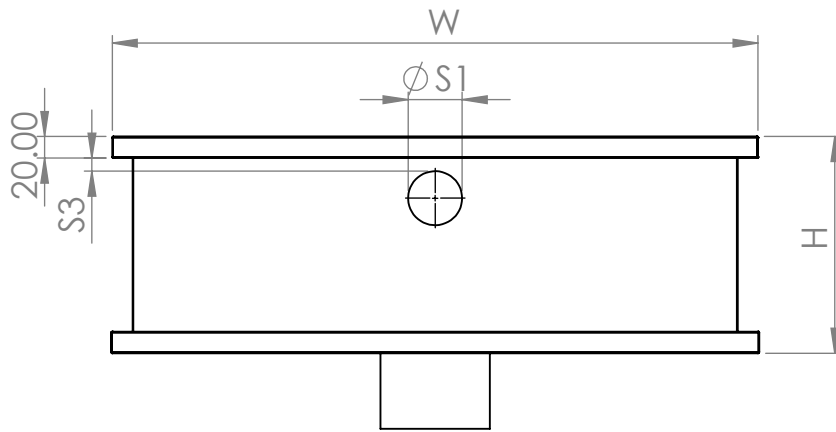

FRONT VIEW

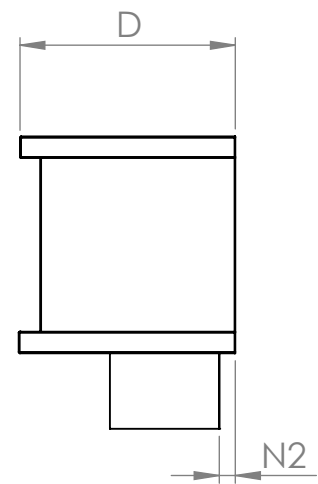

SIDE VIEW

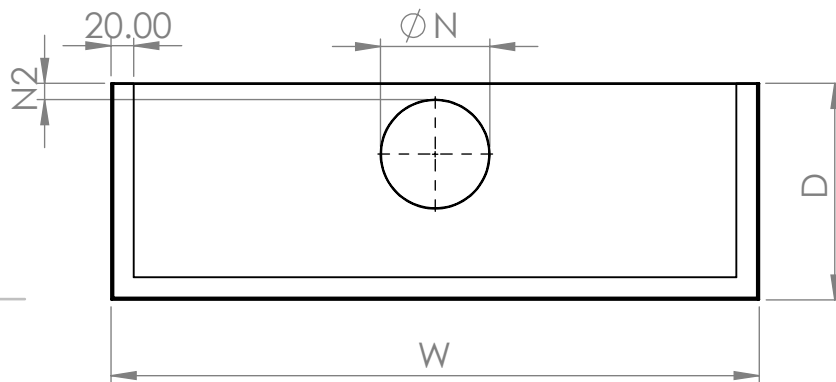

PLAN VIEW

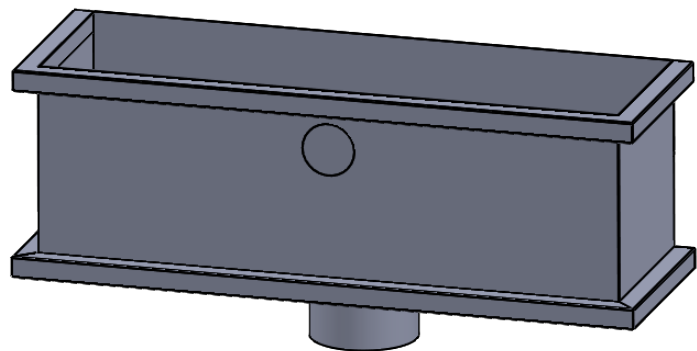

ISOMETRIC VIEW

	B1	B2	H	W	D	Material Availability ( Please tick required):
<b>Small</b>	-	-	300	500	300	<ul style="list-style-type: none"> <li>• 1.20BMT Aluminium - TIG welded</li> <li>• 1.20BMT Aluminium - Powdercoated</li> <li>• 0.70BMT Copper - Soldered</li> <li>• 0.70BMT Galvanized - Soldered</li> <li>• 0.55BMT Stainless Steel - Soldered</li> <li>• 1.20BMT Stainless Steel - TIG welded</li> <li>• 0.70BMT Zinc Mill Finish - Soldered</li> <li>• 0.55BMT Colorbond/Plain - Riveted</li> </ul>
<b>Medium</b>	-	-	400	600	400	
<b>Large</b>	-	-	500	700	500	
<b>Custom</b>						

\*NOTE - Custom sizing would incur additional charges\*

PLEASE INDICATE NOZZLE/OVERFLOW/OTHER DIMENSIONS IN ABOVE DRAWINGS



All dimensions are in millimetres

TITLE

Low Profile

Page

8

WEBSITE: www.kfcroofing.com.au

PH: 02 9810 0915

FILE PATH Z:\Development files\Rainwaterheads Booklet\Low Profile\

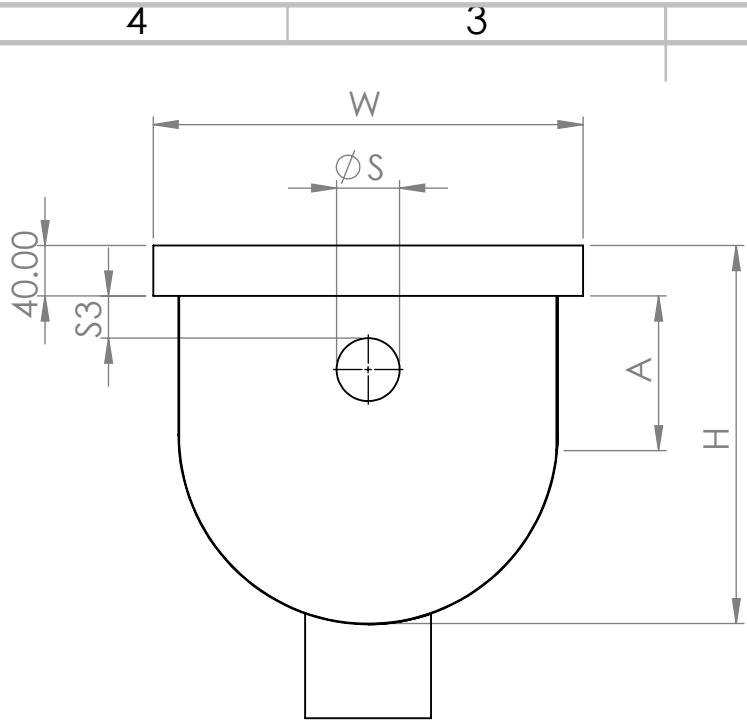

FRONT VIEW

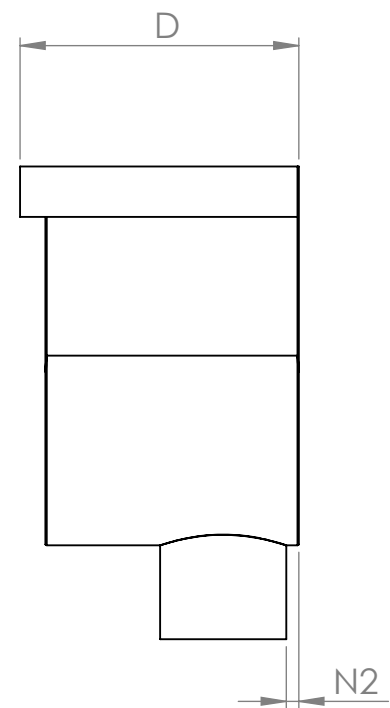

SIDE VIEW

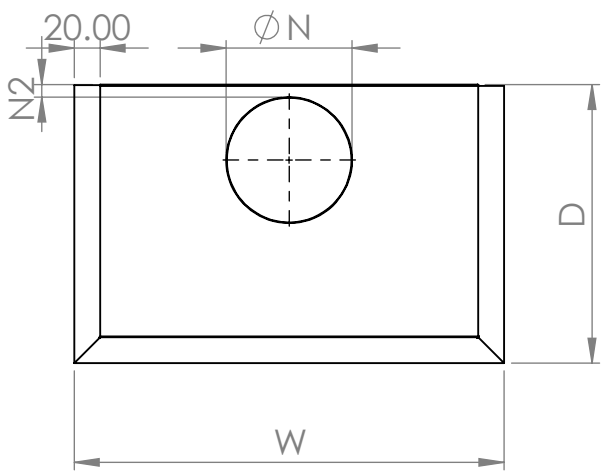

PLAN VIEW

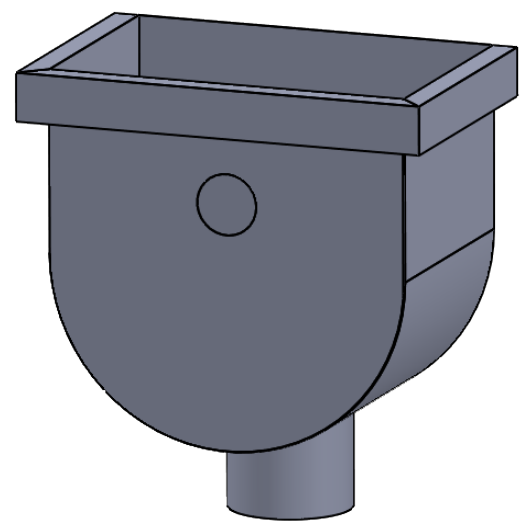

ISOMETRIC VIEW

	B1	B2	H	W	D
<b>Small</b>	-	-	300	300	250
<b>Medium</b>	-	-	400	400	300
<b>Large</b>	-	-	500	500	350
<b>Custom</b>					

- Material Availability ( Please tick required):**
- 1.20BMT Aluminium - TIG welded
  - 1.20BMT Stainless Steel - TIG welded
  - 1.20BMT Aluminium - Powdercoated
  - 0.70BMT Zinc Mill Finish - Soldered
  - 0.70BMT Copper - Soldered
  - 0.55BMT Colorbond/Plain - Riveted
  - 0.70BMT Galvanized - Soldered
  - 
  - 0.55BMT Stainless Steel - Soldered

\*NOTE - Custom sizing would incur additional charges\*

**PLEASE INDICATE NOZZLE/OVERFLOW/OTHER DIMENSIONS IN ABOVE DRAWINGS**



All dimensions are in millimetres

TITLE

U-Shape

Page  
**9**

WEBSITE: [www.kfcroofing.com.au](http://www.kfcroofing.com.au)

PH: 02 9810 0915

FILE PATH Z:\Development files\Rainwaterheads Booklet\U-Shape\

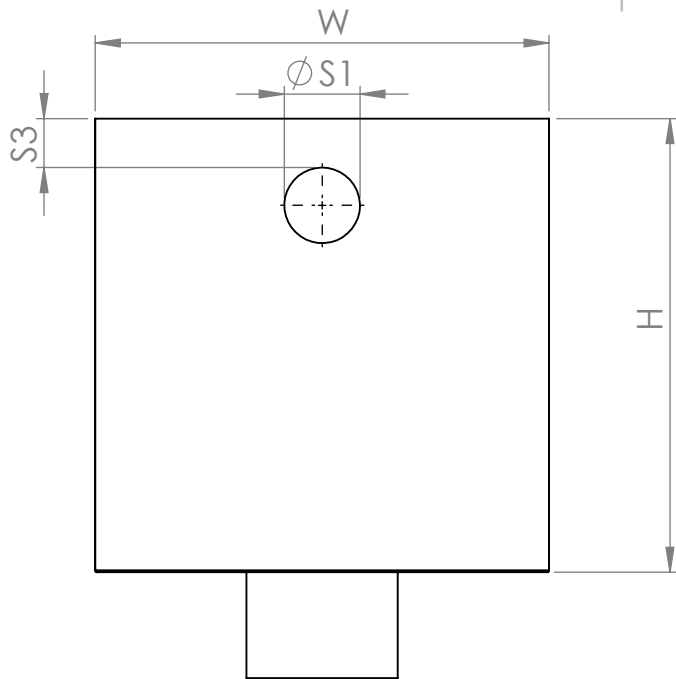

FRONT VIEW

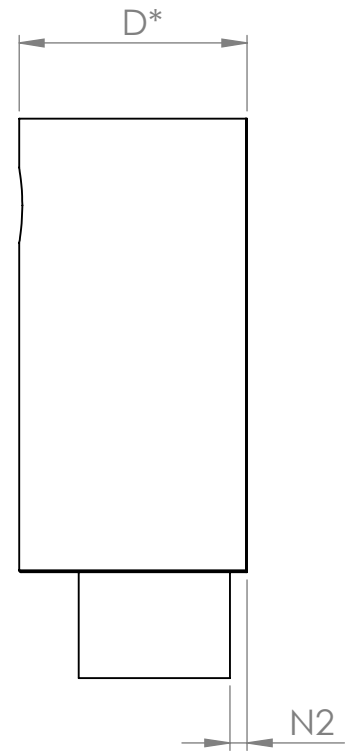

SIDE VIEW

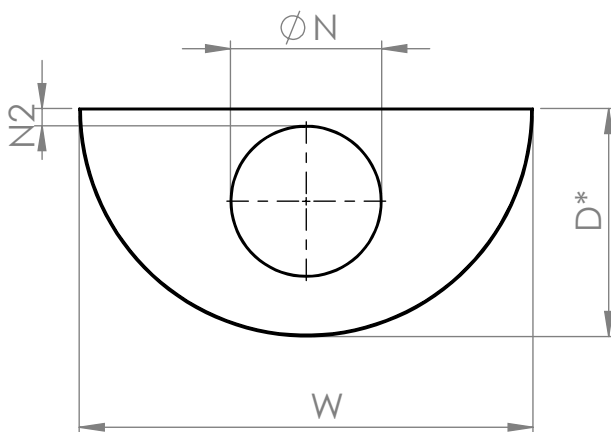

PLAN VIEW

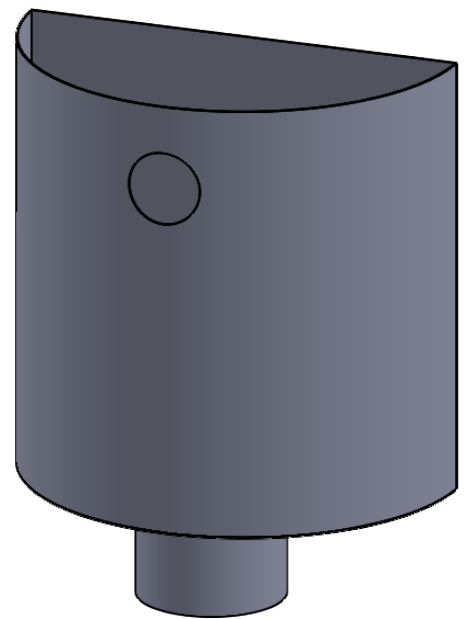

ISOMETRIC VIEW

**\*NOTE - Depth (D) is for reference purpose only and depends on Width(W) of RWH.\***

	B1	B2	H	W	D	Material Availability ( Please tick required):
<b>Small</b>	-	-	400	400	200	<ul style="list-style-type: none"> <li>• 1.20BMT Aluminium - TIG welded</li> <li>• 1.20BMT Aluminium - Powdercoated</li> <li>• 0.70BMT Copper - Soldered</li> <li>• 0.70BMT Galvanized - Soldered</li> <li>• 0.55BMT Stainless Steel - Soldered</li> <li>• 1.20BMT Stainless Steel - TIG welded</li> <li>• 0.70BMT Zinc Mill Finish - Soldered</li> <li>• 0.55BMT Colorbond/Plain - Riveted</li> </ul>
<b>Medium</b>	-	-	500	500	250	
<b>Large</b>	-	-	600	600	300	
<b>Custom</b>						

\*NOTE - Custom sizing would incur additional charges\*

PLEASE INDICATE NOZZLE/OVERFLOW/OTHER DIMENSIONS IN ABOVE DRAWINGS



All dimensions are in millimetres

TITLE

Half Cylindrical

Page

10

WEBSITE: www.kfcroofing.com.au

PH: 02 9810 0915

FILE PATH Z:\Development files\Rainwaterheads Booklet\Half Cylindrical\

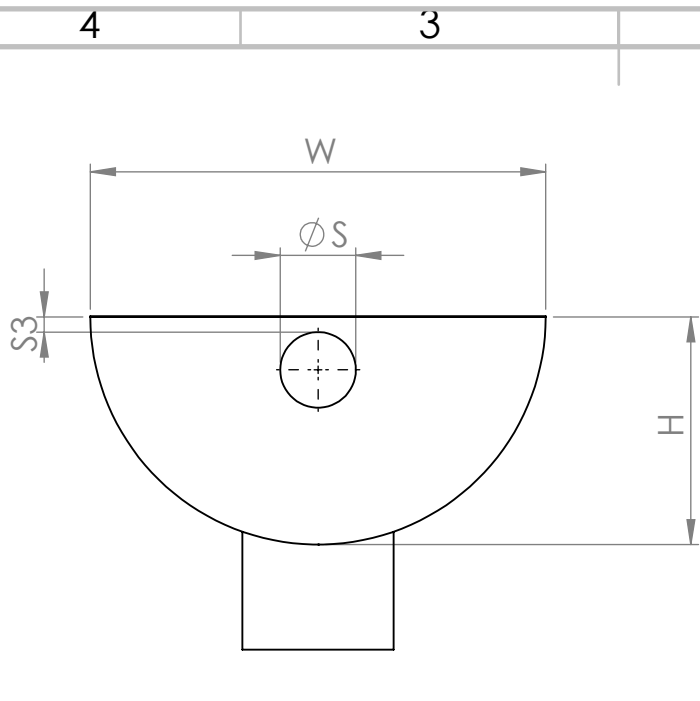

FRONT VIEW

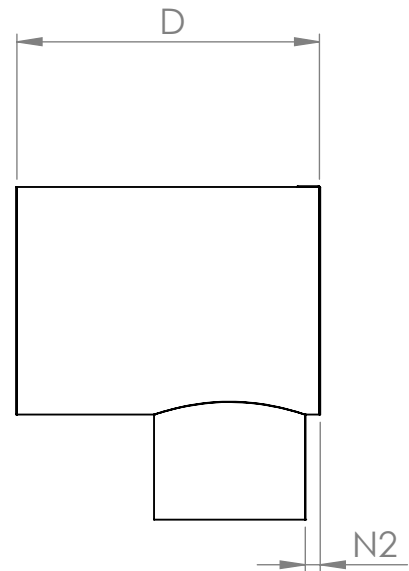

SIDE VIEW

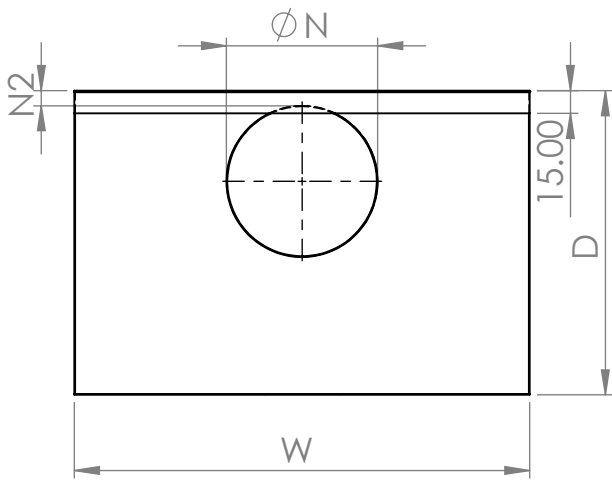

PLAN VIEW

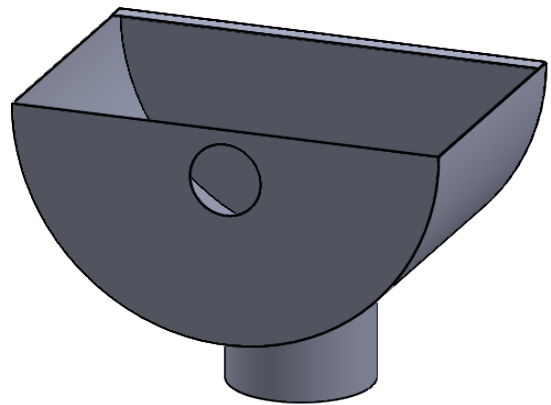

ISOMETRIC VIEW

	B1	B2	H	W	D	Material Availability ( Please tick required):
<b>Small</b>	-	-	200	400	250	<ul style="list-style-type: none"> <li>• 1.20BMT Aluminium - TIG welded</li> <li>• 1.20BMT Aluminium - Powdercoated</li> <li>• 0.70BMT Copper - Soldered</li> <li>• 0.70BMT Galvanized - Soldered</li> <li>• 0.55BMT Stainless Steel - Soldered</li> <li>• 1.20BMT Stainless Steel - TIG welded</li> <li>• 0.70BMT Zinc Mill Finish - Soldered</li> <li>• 0.55BMT Colorbond/Plain - Riveted</li> </ul>
<b>Medium</b>	-	-	250	500	300	
<b>Large</b>	-	-	300	600	350	
<b>Custom</b>						

\*NOTE - Custom sizing would incur additional charges\*

PLEASE INDICATE NOZZLE/OVERFLOW/OTHER DIMENSIONS IN ABOVE DRAWINGS



All dimensions are in millimetres

TITLE

Half round

Page

11

WEBSITE: www.kfcroofing.com.au

PH: 02 9810 0915

FILE PATH Z:\Development files\Rainwaterheads Booklet\Half Round\

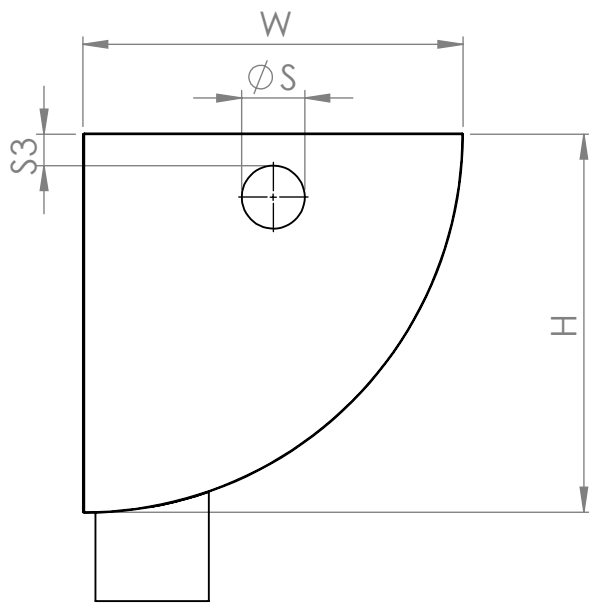

FRONT VIEW

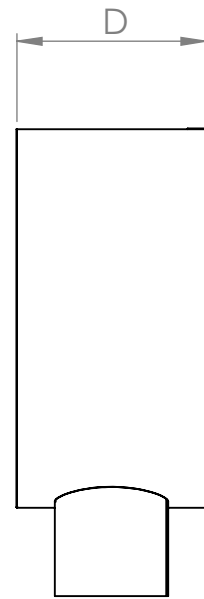

SIDE VIEW

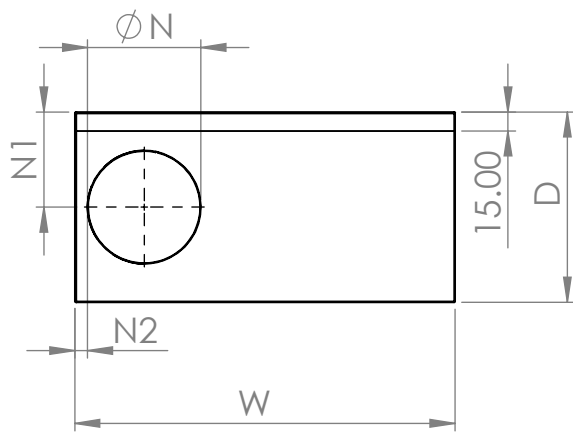

PLAN VIEW

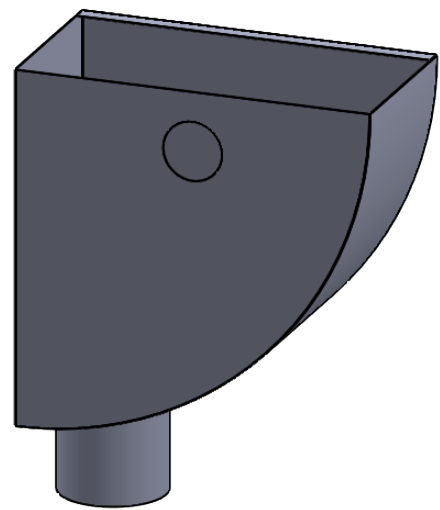

ISOMETRIC VIEW

	B1	B2	H	W	D	Material Availability ( Please tick required):
<b>Small</b>	-	-	300	300	250	<ul style="list-style-type: none"> <li>• 1.20BMT Aluminium - TIG welded</li> <li>• 1.20BMT Aluminium - Powdercoated</li> <li>• 0.70BMT Copper - Soldered</li> <li>• 0.70BMT Galvanized - Soldered</li> <li>• 0.55BMT Stainless Steel - Soldered</li> <li>• 1.20BMT Stainless Steel - TIG welded</li> <li>• 0.70BMT Zinc Mill Finish - Soldered</li> <li>• 0.55BMT Colorbond/Plain - Riveted</li> </ul>
<b>Medium</b>	-	-	400	400	300	
<b>Large</b>	-	-	500	500	350	
<b>Custom</b>						

\*NOTE - Custom sizing would incur additional charges\*

PLEASE INDICATE NOZZLE/OVERFLOW/OTHER DIMENSIONS IN ABOVE DRAWINGS



All dimensions are in millimetres

TITLE

Quarter Round

Page

12

WEBSITE: www.kfcroofing.com.au

PH: 02 9810 0915

FILE PATH Z:\Development files\Rainwaterheads Booklet\Quarter Round\