

Gelmatic 30 M

batch-freezer
for gelato & ice cream production with cold process
water cooled



Easy & fast

High performance batch-freezer that allows to obtain results above market standards.
Easy to use, strong and reliable, it makes artisan's work easy and safe,
as it reaches very low temperature in a very short time.

Technical features

- Dual Mode System, for gelato and premium Ice-cream production
- Charging hopper allows for a fast charge of the mix, flavors and other ingredients
- Front door made in Makrolon® (special thermal insulating material)
- Quick and easy gelato extraction
- Acoustic signal tells you when gelato is ready
- Automatic temperature control thanks to advanced thermoregulators with "sensible touch" displays
- Dedicated program for premium ice cream production
- Cylinder type: patented stainless steel "multi-point" injection system
- Refrigeration system: patented stainless steel plate condenser
- Three blade stainless steel mixer with interchangeable scrapers
- Two-speed mixer
- Probe in direct contact with the mix

Advantages and strengths

- Gelato or ice cream batches produced in a very short time
- Easy to use, the machine is exceptionally functional
- Electronic control of working cycle through temperatures
- Extremely easy to handle and clean
- Short freezing time



Gelmatic 30 M

batch-freezer
for gelato & ice cream production
with cold process
water cooled

Model:
Quantity:
Project:
Company:
Contact:
Dealer ID:

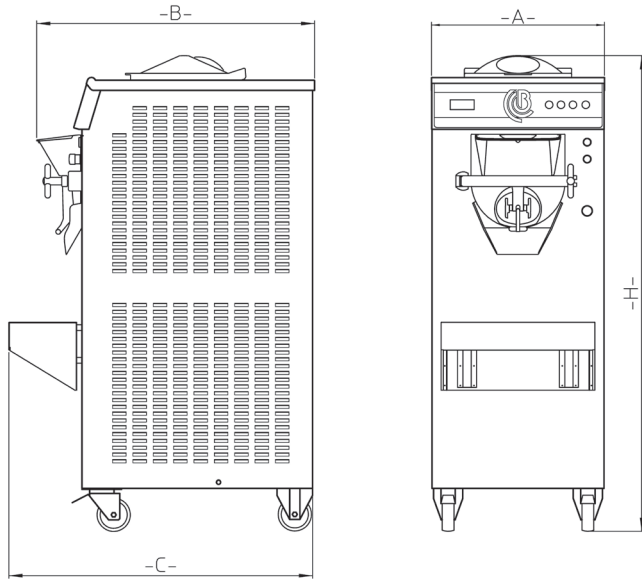

Side view

Front view

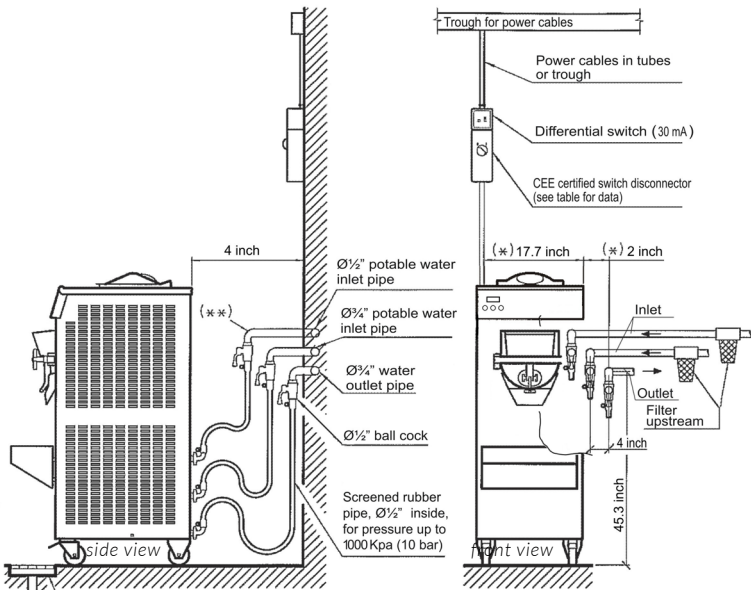

(*) The dimensions of the machines may vary but the water and electrical connections are always on the left hand side of the machines

(**) The cock is shown raised only for purposes of illustration. In fact it is next to the other one.

MAKE THE SAME CONNECTIONS FOR EACH MACHINE

Width (A)	cm	51	inches	20,1
Depth (B)	cm	80	inches	31,5
Depth with base (C)	cm	87,5	inches	34,4
Height (H)	cm	140	inches	55,1
Weight	kg	220	lbs	485
Frame type	floor model			
Outer panels	stainless steel			
Capacity per cycle	Liters	5	Gal	1,32
Max. hourly production	Liters	38	Gal	10
Min. mix per cycle	Kg	2	Lbs	4,4
Max. mix per cycle	Kg	4	Lbs	8,8
Volume cylinder with mixer	Liters	8,93	Quarts	9,43
Volume cylinder without mixer	Liters	9,46	Quarts	10
Min. mixer speed	RPM 150			
Max. mixer speed	RPM 300			
Max power	kw	3,7	Hp	5
Voltage	230 Volt / 60 Hz / 3 phase			
Breaker size	Amp 25			
Drive motor	kw	2,2	Hp	3
Compressor power	kw	1,5	Hp	2
Compressor power	BTU/h 4688			
Freon R404A	Gr	1150	Oz	40,5
Refrigeration condensation	Water			
Water connection	Ø	inches		1/2
Min. water pressure	bar	2	psi	29
Max. water pressure	bar	3	psi	43,5
Crate dimensions	cm	100x70x177	inches	39,4x27,6x69,7
Crate weight	kg	294	lbs	648



Warranty: valid for the North American Continent (Canada, USA)
Extension: 12 months parts (with check list and warranty signed and mailed)
5 years compressor with registration on warranty.bravonorthamerica.com



Bravo North America Inc. Office & Showroom, 810 Tyvola Road, Suite 130, Charlotte, NC 28217
tel. +1 980 237 2474 bravonorthamerica.com info@bravonorthamerica.com