



## **Connah's Quay A, B & C: Past, Present & Future**

Robert Logan & Michael Donnelly



## Connah's Quay A & B

Robert Logan: Engineering Manager, Connah's Quay CCGT

## Coal Generation at Connahs Quay “A” 1954 - 1984

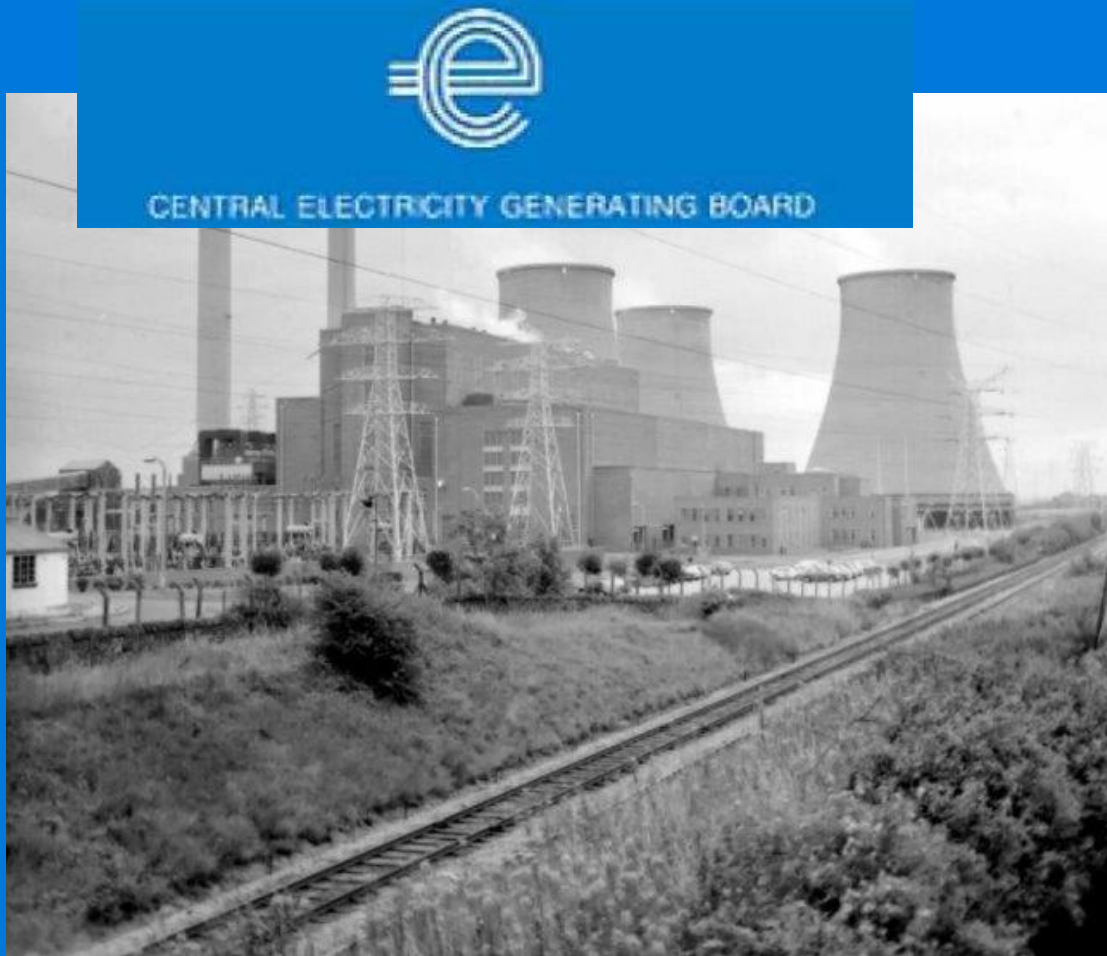

Our journey began at the coal fired power plant which was built to replace a smaller power station in Queensferry.

Originally it was set to generate a max output of 60MW but ended being upgraded to 180MW due to increased demand.

There were 6 x 30MW alternator sets with 6 corresponding boilers.

The two chimneys were 300 ft high and had a 16ft diameter making it one of the largest in Europe at the time.

The power station consumed roughly 10,000 tonnes of coal a week which was brought in by rail wagons.

It was finally demolished in 1992, 8 years on from closure.

## Connahs Quay “B” CCGT Site 1996 - Present



Connah's Quay is a 1,420 MW gas fired power station that opened in 1996 during the 'Dash for Gas'.

This plant cost £580m and was opened on the 4th July 1996 by Powergen which later became EON.

In 2015 the plant was transferred to Uniper and remains their largest UK CCGT power station.

The plant runs on natural gas and has 4 x 330 MW units.

Liverpool Bay gas field was linked to the power station along the natural gas pipeline however this ceased production in 2023.



# Connahs Quay "B" CCGT Site

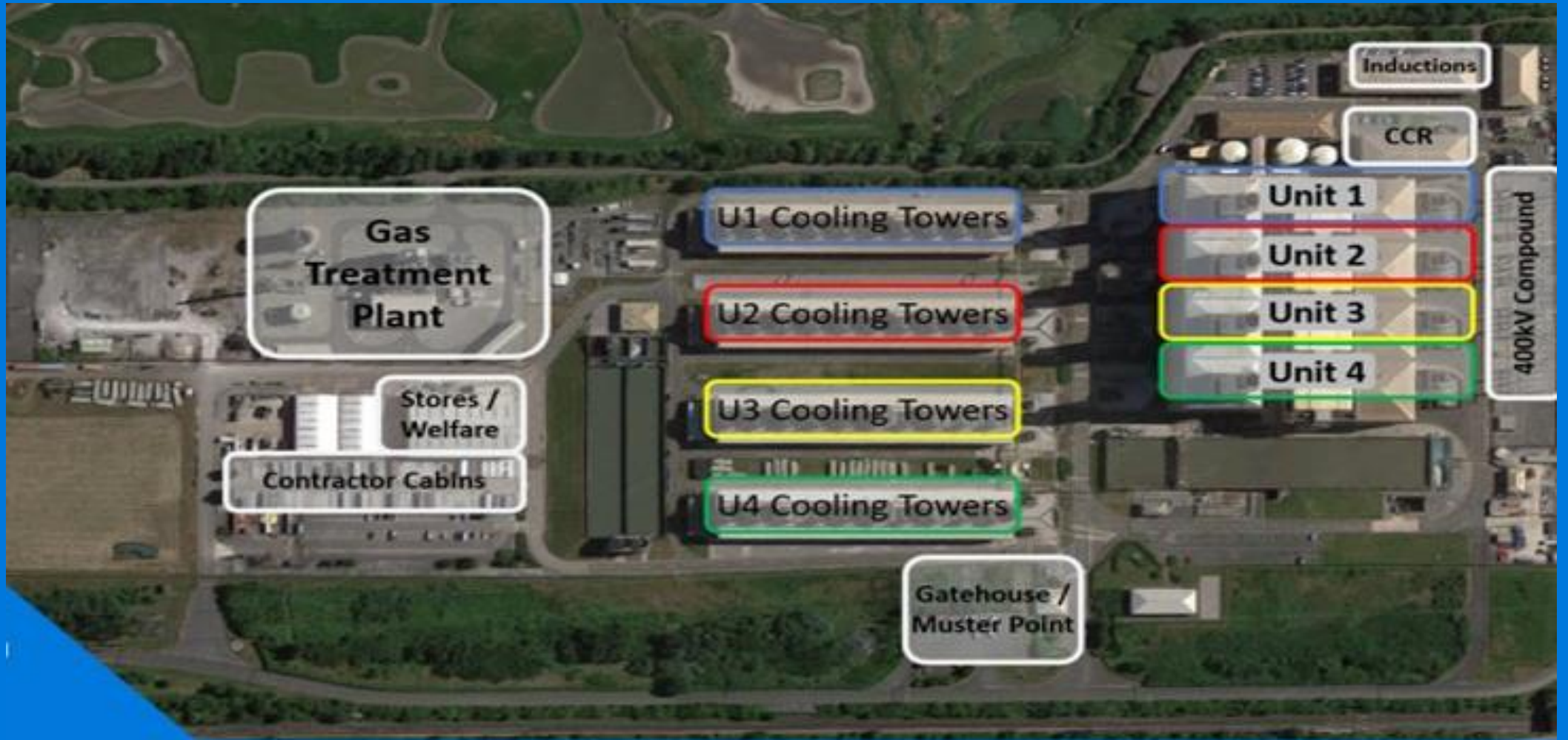

# Connahs Quay "B" CCGT Site Technology

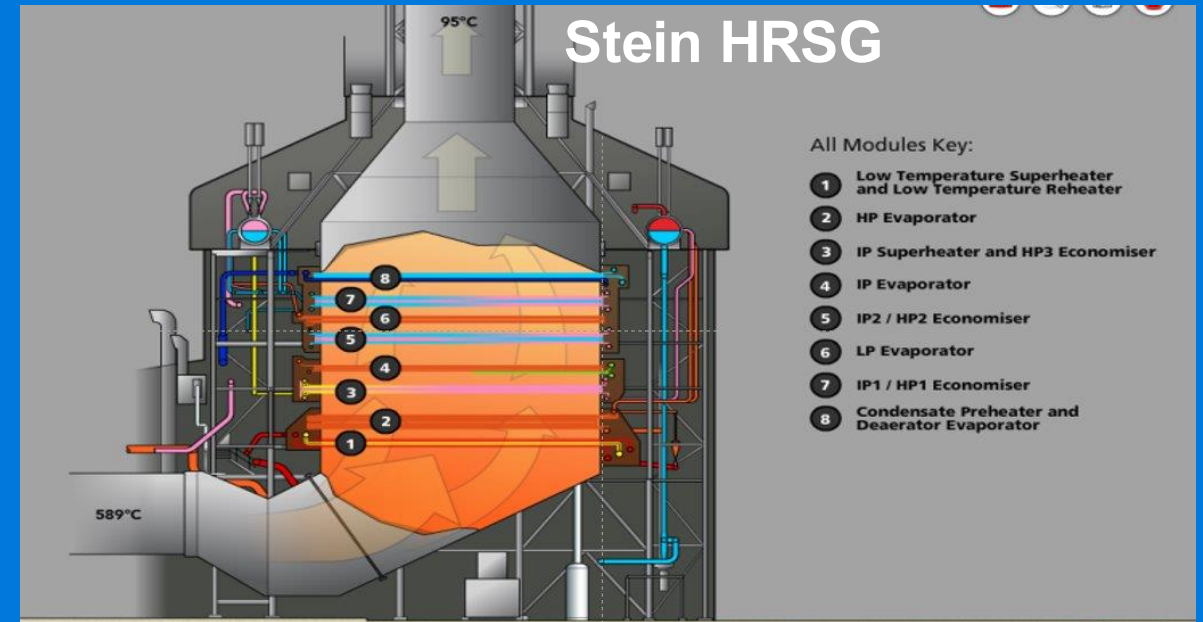
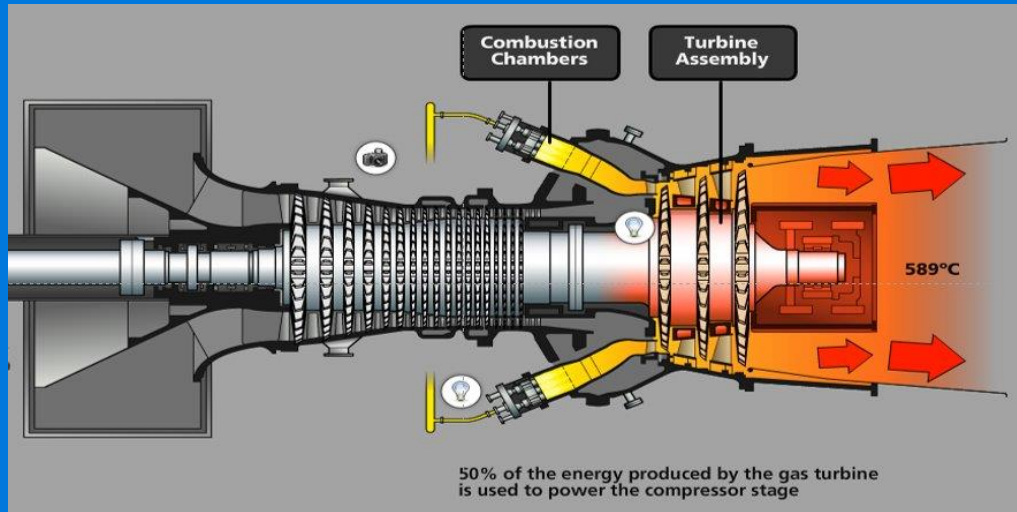

## GE 9FA Gas Turbines

## GEC Steam Turbine & Generator

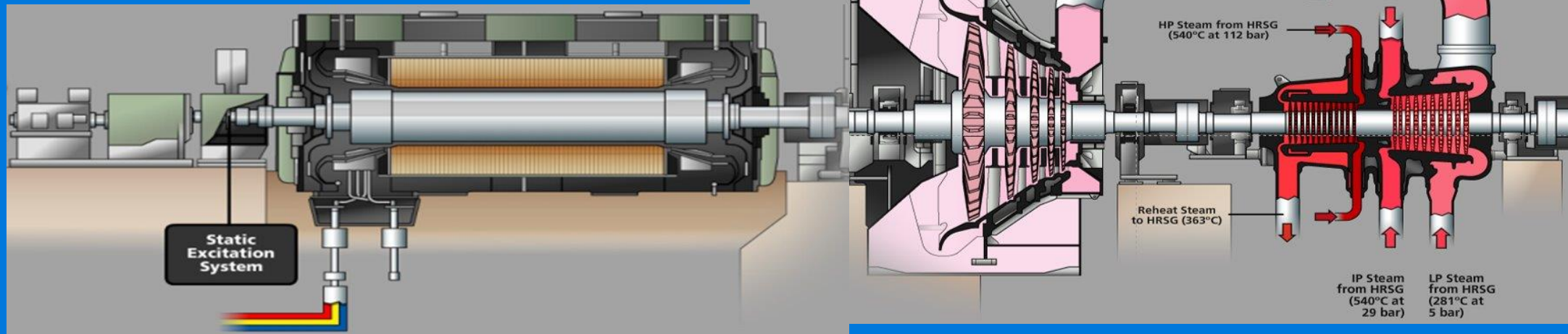

# Today's UK Electricity Market

Data from "TerraVolt"  
On 9/4/26

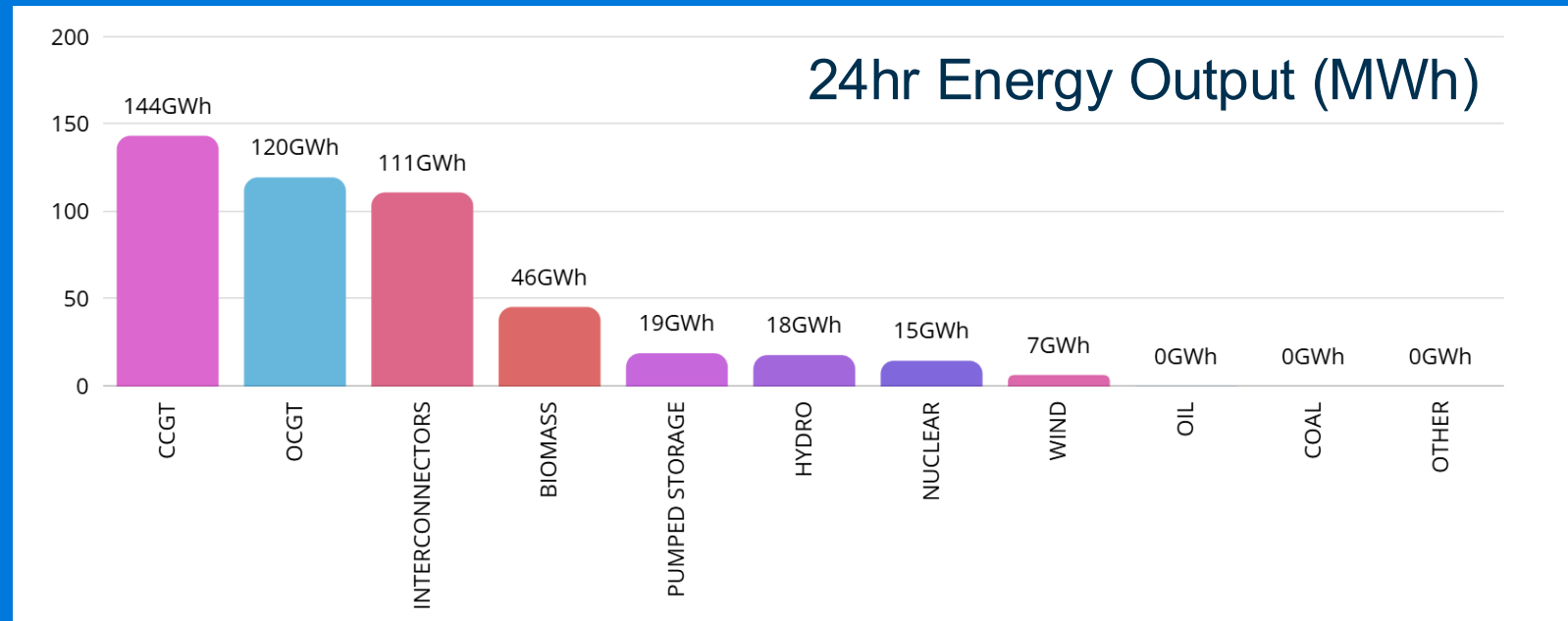
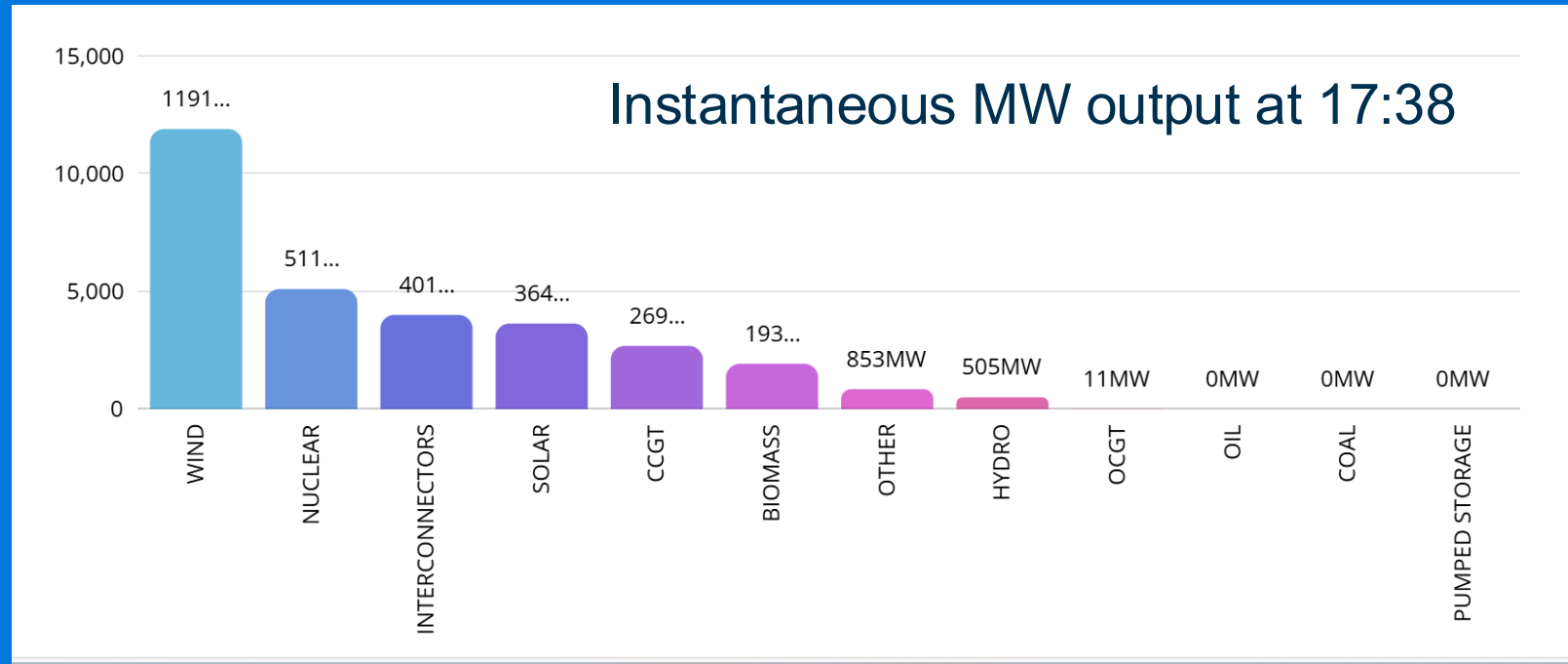

# Connahs Quay "B" Site

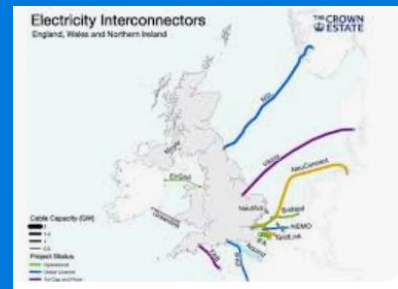
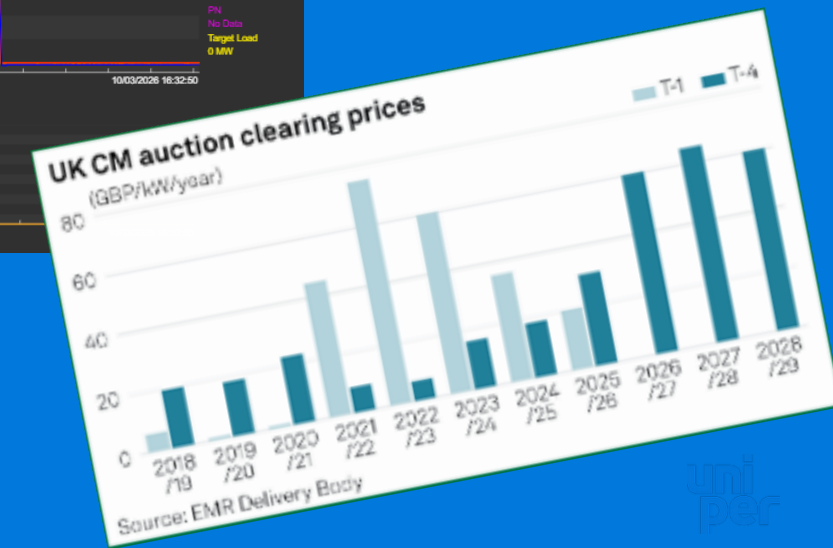



# Connah's Quay Low Carbon Power

Amine Post-Combustion Capture from CCGT and EFW Plants:  
FERF's Carbon Capture and Storage Interest Group (15th April 2026)

Michael Donnelly

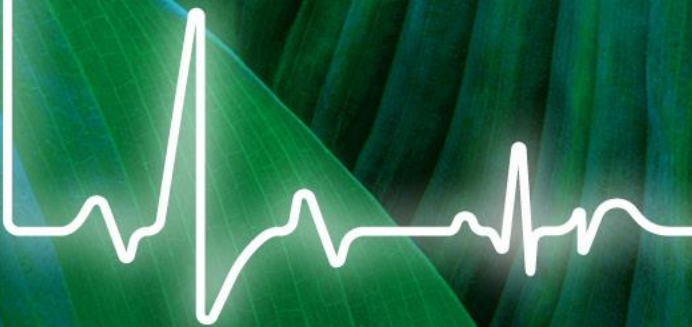

The beating heart of energy.

# Our strategy – secure today, carbon-neutral by 2040

**Uniper set course to secure energy supply, accelerate the energy transition, and investing ~€8 billion by the early 2030s, aiming for carbon neutrality by 2040.**

Our decades of experience, diversified portfolio and global reach enable us to supply our ~1,000 customers, industries and everyday life – just as the heart powers the body.

Europe's energy system needs a steady heartbeat to deliver an uninterrupted, flexible supply of renewable and low-carbon energy.

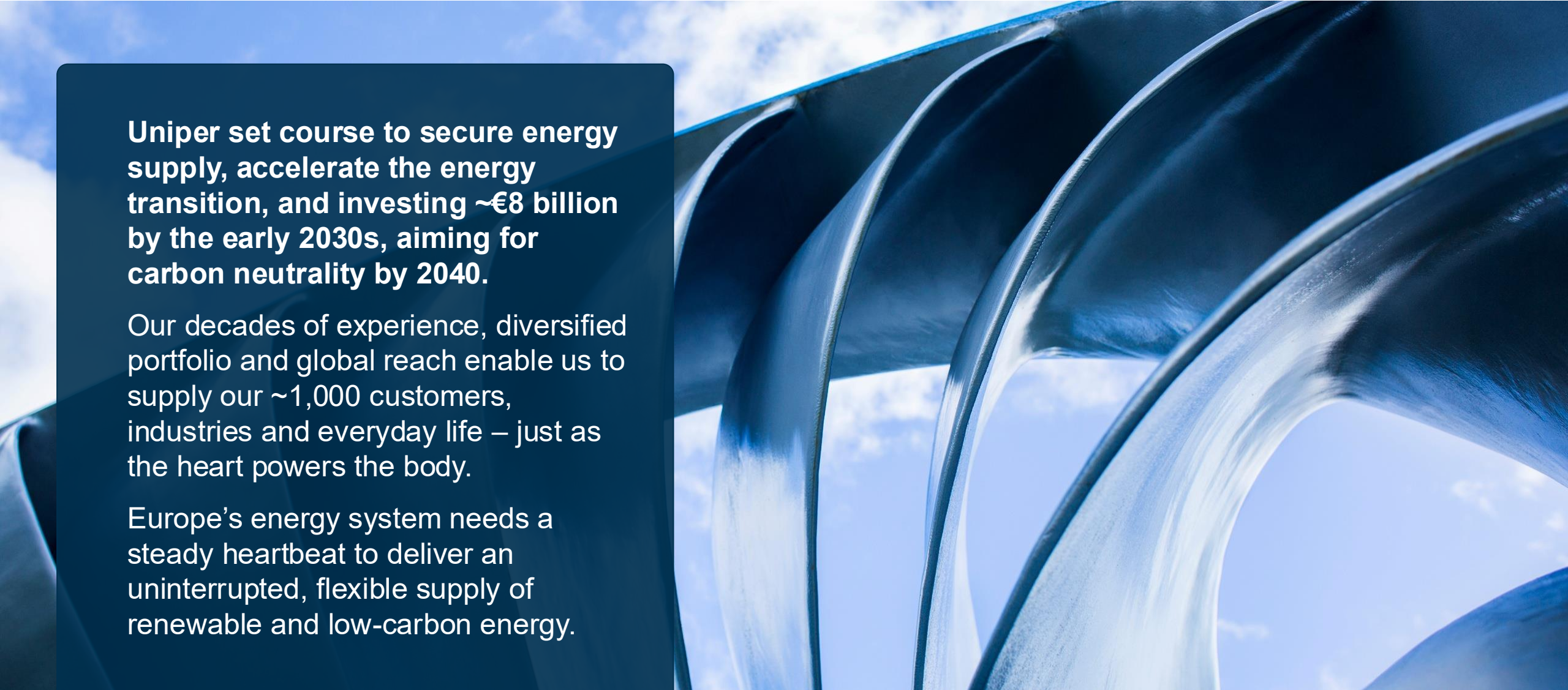

# Connah's Quay Low Carbon Power



Uniper is developing plans for the Connah's Quay Low Carbon Power project, which if consented and developed, is expected to consist of:

- A new combined cycle gas turbine (CCGT) power station capable of providing up to a maximum of 1.38 GW\* of low carbon power
- Carbon capture technology to enable ~95% of carbon dioxide (CO<sub>2</sub>) emissions from the CCGT to be captured
- A connection to CO<sub>2</sub> transport and storage infrastructure as part of the HyNet industrial cluster

**The proposed new CCGT power station with carbon capture would contribute towards a secure and reliable power system by generating low carbon power to meet the growing need for electricity, whenever it is required, supporting the UK's transition to a decarbonised economy.**

\*The new power station is expected to be developed in two phases; with roughly half its eventual capacity of low carbon power delivered in phase one and a later expansion up to a maximum of 1.38GW of low carbon power in total. Final capacity will be determined following completion of Front End Engineering Design in early 2026.

# Connah's Quay: a strategic site

*Repurpose of existing pipeline previously used to bring natural gas from Liverpool Bay*

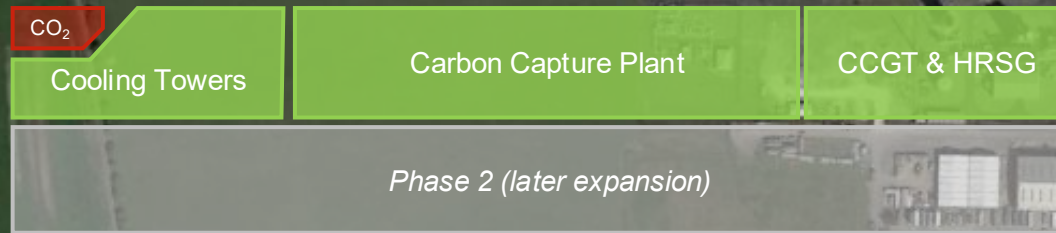

Cooling Water

Grid

**The Connah's Quay site has many advantages, including the ability to reuse existing strategic infrastructure connections including cooling water, gas and grid connections as well as an existing pipeline connection that can be repurposed for the transport of captured CO<sub>2</sub>.**

# The route to FID



# For more information please contact:

Uniper SE  
Holzstraße 6  
40221 Düsseldorf  
Germany  
[info@uniper.energy](mailto:info@uniper.energy)  
[www.uniper.energy](http://www.uniper.energy)



This presentation may contain forward-looking statements based on current assumptions and forecasts made by Uniper SE Management and other information currently available to Uniper. Various known and unknown risks, uncertainties and other factors could lead to material differences between the actual future results, financial situation, development or performance of the company and the estimates give here. Uniper SE does not intend, and does not assume any liability whatsoever, to update these forward-looking statements or modify them to conform with future events or developments.

**Uniper. The beating heart of energy.**

