

HunterDouglas

Installation



16 Shade DC Power Supply Wiring Guide PowerView® and SoftTouch™ Motorization



CONTENTS

GETTING STARTED

Safety.....	1
Maintenance.....	2
Product View.....	2
Tools and Fasteners Needed	3

INSTALLATION

Components.....	4
Specifications	4
Dimensions	4
Schematic	5
Installation Overview.....	6
STEP 1 — Mounting Applications.....	6
STEP 2 — Wiring.....	8
STEP 3 — Connect the Power Source	12
STEP 4 — Install the Enclosure Cover	14

Questions?

Call Hunter Douglas Consumer Support at **1-888-501-8364**.

Safety

IMPORTANT: For replacement, only use the provided 6' IEC power cord, equivalent UL 14 AWG 3-conductor SJT 6' power cord, or permanent wiring.

- To reduce the risk of electric shock, this appliance has a grounding-type plug (three prongs). This plug will only fit into a grounding receptacle (three slots). If the plug does not fit into the receptacle, contact a qualified electrician to install the proper grounding-type outlet. Do not alter the three-prong plug in any way.
- If permanent wiring is to be used, then you are required to follow local codes (NEC) for all wiring and safety.
- This appliance has a grounding-type pin for receptacle connection which must be used. NEVER modify or remove the ground. A ground is necessary for proper operation.
- For field wiring between the Class 2 output of the 16 Shade DC Power Supply and the shades, ONLY use Class 2, or better, flammability-rated wiring. The wiring must also meet VW-1 and FT-1 flame rating standards.
- Do not use an extension cord. If the provided 6' power cord does not reach a grounding-type wall receptacle, have a qualified electrician install a new grounding-type wall receptacle within 6 feet of the appliance.

GETTING STARTED

Maintenance

- Perform inspection yearly to verify the serviceable fuse is in working condition. If necessary, replace the fuse with the same, or equivalent fuse type. ALWAYS remove power before servicing.

Product View

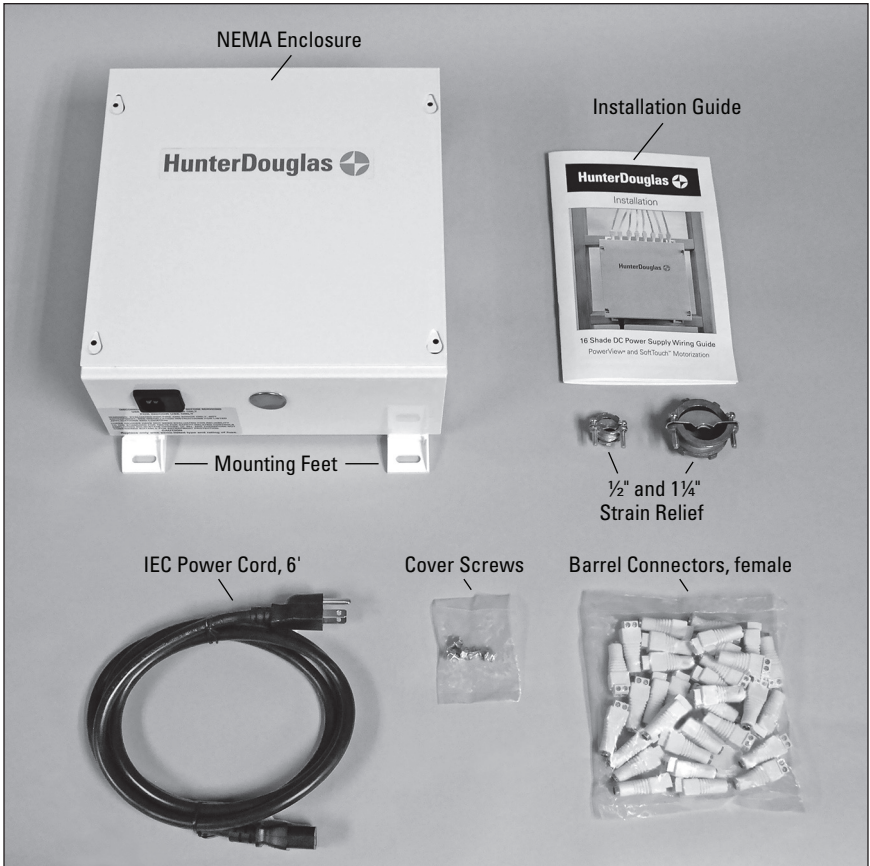

Thank you for purchasing the Hunter Douglas 16 Shade DC Power Supply. With this power supply properly installed, you will be able to power up to sixteen Hunter Douglas PowerView® or SoftTouch™ Motorization shades.

Tools and Fasteners Needed

- Flat blade screwdriver
- #1 Phillips screwdriver
- Level (laser level is recommended)
- Measuring tape and pencil
- Power drill and 1/8" drill bit
- #2 and #3 Phillips screw bits
- Wire cutter and wire stripper
- 14/2, 16/2, or 18/2 AWG low-voltage electrical wire (Not Provided)
- Wire Connectors (Optional, Not Provided).

NOTE: In addition, you will need fasteners designed to work with your specific mounting surface(s). Mounting fasteners are not included due to the wide variety of mounting surfaces. The installer should determine the appropriate mounting fasteners for their mounting needs.

GETTING STARTED

Components

When unpacking the power supply, be sure the following components are included:

- One NEMA enclosure with power supply, cover, and cover screws (cover pre-installed onto NEMA enclosure)
- One 6' IEC power cord
- One ½" strain relief and one 1¼" strain relief
- One package of barrel connectors, female (32 count)
- Four mounting feet (pre-installed onto NEMA enclosure)
- Installation guide



WARNING: To reduce the risk of fire, electric shock, or injury to persons, installation work and electrical wiring must be done by a qualified person in accordance with all applicable codes and standards.

Specifications

Input: 120V AC, 6A

Output: 18V DC, 90 Watts

Wire Compatibility: 14–18 AWG Wire

Circuit Class: 2

Dimensions

Length: 10" (without mounting feet)

12¼" (with mounting feet)

Width: 10"

Depth: 4¼"

Weight: 10 lbs

Schematic



WARNING: Do not place more than two 16 Shade DC Power Supplies on a single home circuit with a 15 amp breaker.

HunterDouglas

The Main Disconnect and Branch Circuit Protection Shall Be Provided By Installer Listed Circuit Breaker, Rated: 120V, 15A

**USE COPPER CONDUCTORS
INDOOR USE ONLY
RATED 70C
6 FLA TOTAL
REV B**

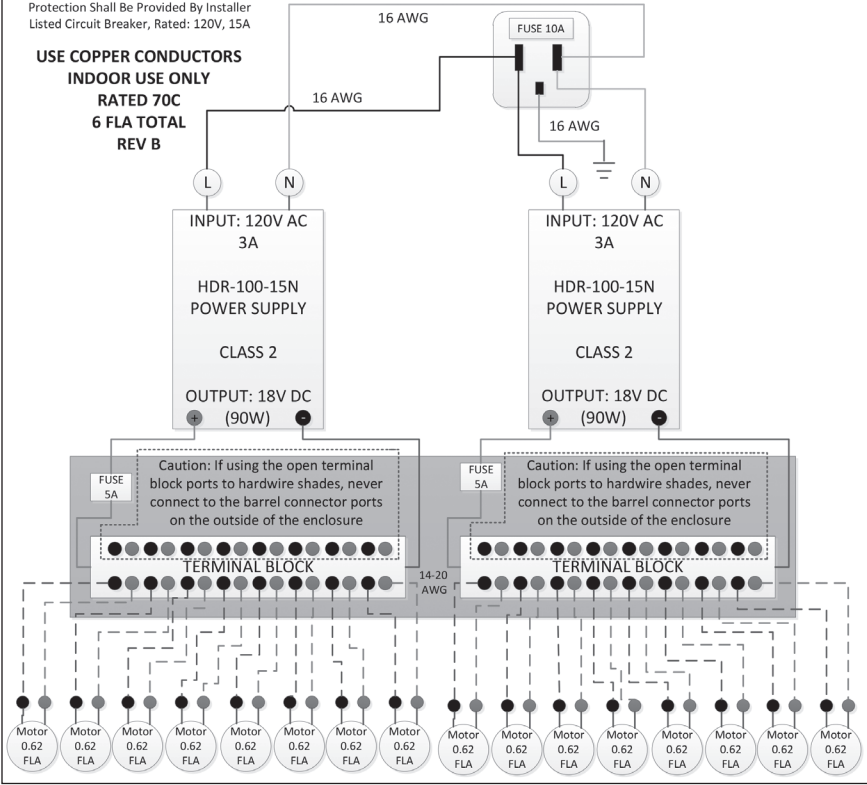

INSTALLATION

Installation Overview

To install your 16 Shade DC Power Supply, you will need to complete the following four steps:

STEP 1: Mounting Applications

STEP 2: Wiring

STEP 3: Connect the Power Source

STEP 4: Install the Enclosure Cover

Step 1: Mounting Applications

The 16 Shade DC Power Supply may be surface mounted or recess mounted within the wall.

NOTE: The four mounting feet are preinstalled on the enclosure.

Surface and Recessed Mounting for the Enclosure

For recessed mounting, mount the enclosure so that it protrudes from the front of the stud by a measure equal to the thickness of the finished wall. The front of the enclosure should be visible and flush with the surface of the finished wall.

If using the Mounting Feet

- Place the enclosure on an appropriate mounting surface and mark the location of the screw holes.

NOTE: Studs or solid wood are the preferred mounting surface.

IMPORTANT: If mounting to drywall, two of the mounting feet should be secured to a stud and two should be secured to drywall anchors.

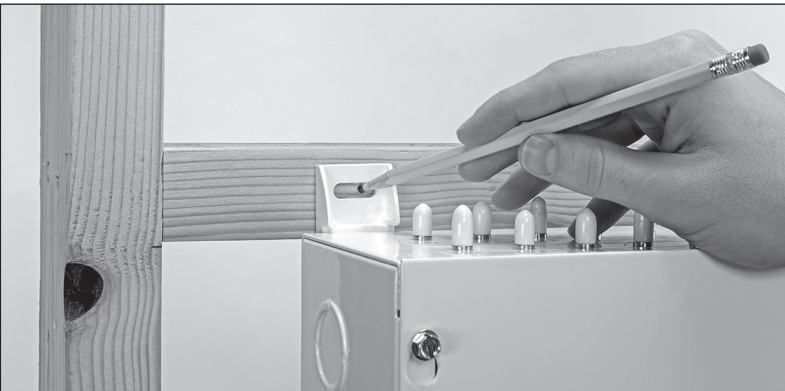

- Drill the screw holes using a 1/8" drill bit.

- Attach the enclosure to the mounting surface with screws, which go through the holes in the mounting feet.



If not using the Mounting Feet for Surface or Recessed Mounting

- You may optionally remove the mounting feet.
 - On the inside of the enclosure, remove the screws that secure the four mounting feet to the enclosure.
 - Secure the enclosure to an appropriate mounting surface.
 - Use the four pre-drilled holes located on the back panel of the power supply enclosure.
- NOTE:** Studs or solid wood are the preferred mounting surfaces.

Side Mounting for the Enclosure (Optional)

- Secure the enclosure to an appropriate mounting surface.
 - Use the pre-drilled holes located on the side panels of the power supply enclosure.
- NOTE:** Studs or solid wood are the preferred mounting surfaces.

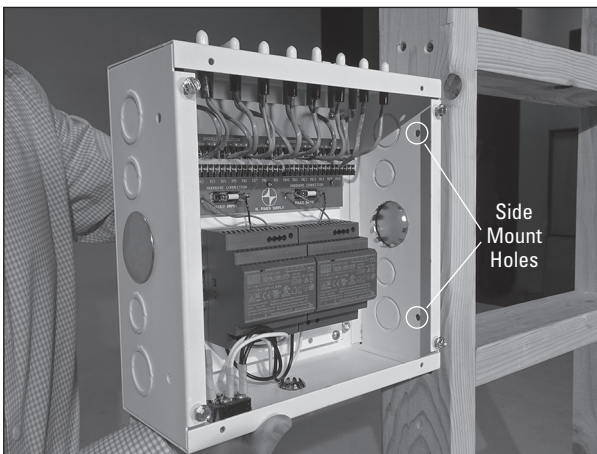

INSTALLATION

Step 2: Wiring

The 16 Shade DC Power Supply uses low-voltage electrical wiring to supply power to the shade motors. Wire terminations must be made at both the power supply as well as the shade. Wire terminations at the power supply may be made by using either screw-to-terminal barrel connectors or the terminal ports inside the power supply enclosure. Two-stranded 14, 16, or 18 gauge low-voltage electrical wiring may be used with 16 Shade DC Power Supply. See the table below for maximum wire run distances for each wire gauge.

Wire Gauge	Type	Maximum Run Distance
18/2	2-conductor AWG electrical wire	150 feet
16/2	2-conductor AWG electrical wire	300 feet
14/2	2-conductor AWG electrical wire	450 feet

Wire Terminations at the Power Supply

Surface Mount Applications

- Strip ¼" of the insulation material away from the end of the electrical wiring.

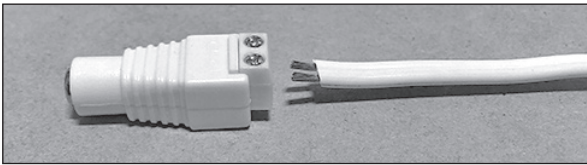

- Loosen the two screw terminals on each barrel connector with a #1 Phillips screwdriver.

IMPORTANT: The screw terminals are marked + and – to show which electrical polarity should be connected to a terminal.

- Insert the positive and negative wires into the correct terminal and tighten the screws with a screwdriver.
- Plug the female barrel connector into the male connector on outside of the enclosure.



Recessed Mount Applications

CAUTION: If using the terminal block ports on the inside of the enclosure to hard-wire the shades, do not connect barrel connectors to the male connectors on the outside of the enclosure.

- Route the electrical wiring to the shades through one of the punch-outs in the enclosure.
 - For the pre-drilled punch-out, as shown below, use the 1¼" strain relief (provided). For one of the other punch-outs, use the appropriate size strain relief (not provided).

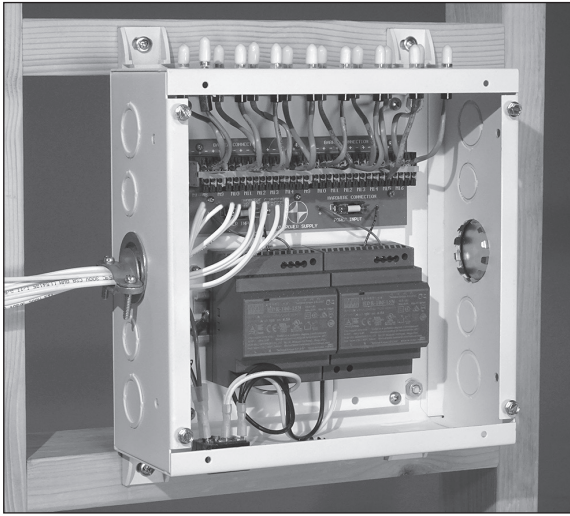

- Strip 3/8" of the insulation material away from the end of the electrical wiring.
- Insert the stripped electrical wiring into the positive/negative pairs of ports in the terminal block.

CAUTION: There are 16 pairs of open ports in the terminal block. The ports are marked to show which electrical polarity should be connected to each port as well as the motor number. Make certain the wires from each shade are connected to the correct corresponding positive or negative port and motor number. Ensure the wire fits securely in the terminal port and that adjacent conductors do not touch.

- Push down on the top of the terminal port with a screwdriver, then insert the wire.

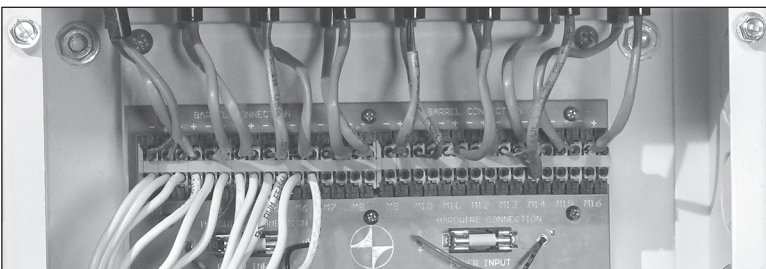

INSTALLATION

Wire Terminations at the Shade

Wire terminations at the shade are made by connecting the electrical wiring to a provided female barrel connector. The female barrel connector is then connected to the power cable coming from the shade.

- Drill a hole in the side of the frame (IB), or above the window header (OB), for the electrical wiring.
- Thread the electrical wiring through the drilled hole.

Outside Mount

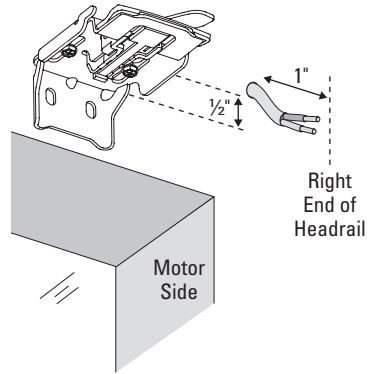

Inside Mount — Wiring from the Head Jamb

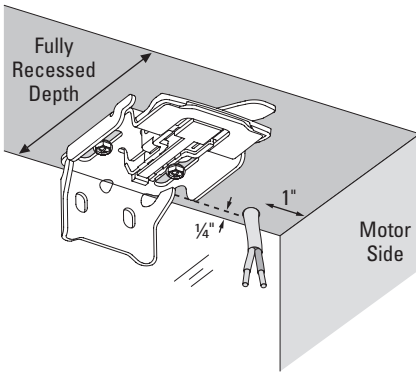

Inside Mount — Wiring from the Side Jamb

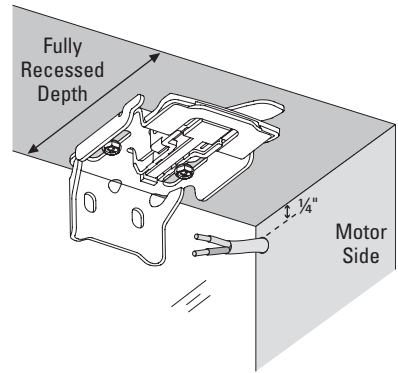

- Strip 1/4" of the insulation material away from the shade end of the electrical wiring.
- Loosen the two screw terminals on the barrel connector with a #1 Phillips screwdriver.

IMPORTANT: The screw terminals are marked + and – to show which electrical polarity should be connected to a terminal. Ensure the wire fits securely in the screw terminal and that adjacent conductors do not touch.

- Insert the positive and negative wires into the correct terminal and tighten the screws with a screwdriver.

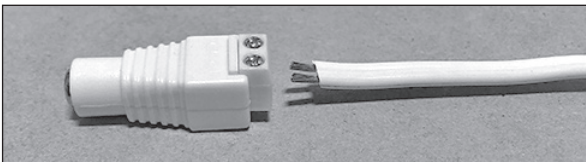

- Locate the power cable coming from the shade.

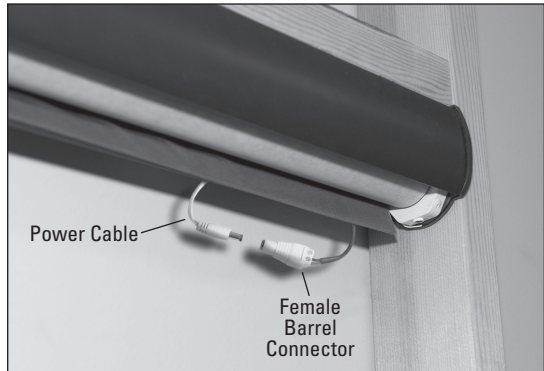

- Plug the female barrel connector into the power cable.



- Hide the power cable and female barrel connector behind the shade to prevent interference with the operation of the shade.



INSTALLATION

Step 3: Connect the Power Source

Provide 120V AC power to the enclosure.



WARNING: To reduce the risk of fire, electric shock, or injury to persons, installation work and electrical wiring must be done by a qualified person in accordance with all applicable codes and standards.

Surface Mount Applications

- Plug the provided power cord into the IEC power inlet on the bottom of the enclosure.
- Plug the other end of the power cord into a standard 120V AC outlet.



Recessed Mount Applications

CAUTION: Turn off local electrical power before making any electrical connections.

- Disconnect the hot, neutral, and ground connectors from the IEC power inlet inside the enclosure.

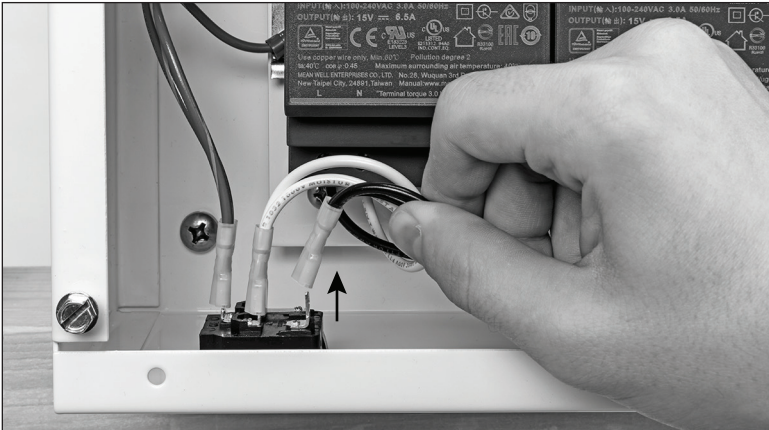

- Cut off the three connectors, leaving three sets of unterminated wires.

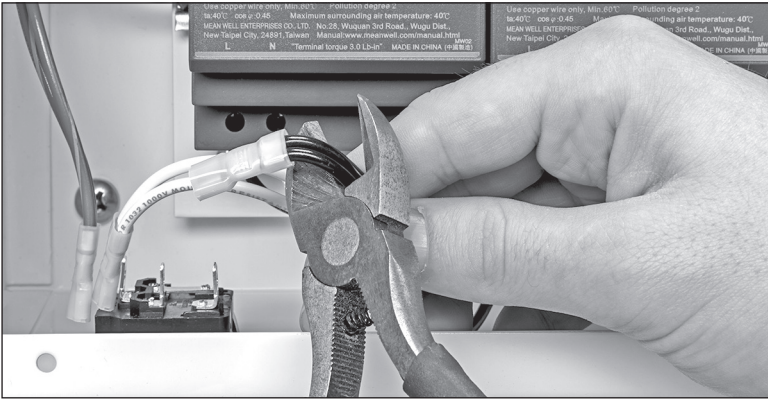

- Strip $\frac{1}{2}$ " of the insulation away from each of the six wires.
- Remove the knock-out plug from the bottom-center of the enclosure.
- Route appropriate field wiring through the hole in the bottom of the enclosure. When using NM cable, use the $\frac{1}{2}$ " strain relief (provided).
- Strip $\frac{1}{2}$ " of the insulation away from the incoming hot, neutral, and ground wires.
- Use wire nuts or other approved wire connectors (not provided) for the following connections:
 - Connect the incoming hot wire to the two black wires inside the enclosure.
 - Connect the incoming neutral wire to the two white wires inside the enclosure.
 - Connect the incoming ground wire to the two green wires inside the enclosure.

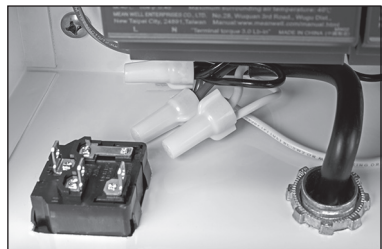

- Turn on power at the circuit breaker.

INSTALLATION

Step 4: Install the Enclosure Cover

- Prior to installing the cover, loosen or install the cover screws part way.
- Place the large holes in the cover over the loosened cover screws, push back, then slide the cover down until hooked by the small holes.
- Secure the cover by tightening the cover screws with a flat blade screwdriver.



HunterDouglas 

hunterdouglas.com