

Find each product. Show your work.

| | | | |
|--------------------|---------------------|-----------------------|---------------------|
| 1. 238×5 | 2. 832×156 | 3. $4,899 \times 67$ | 4. 756×300 |
| 5. 19×863 | 6. 188×732 | 7. $3,249 \times 173$ | 8. 609×840 |

Find each quotient. Show your work.

| | | | |
|-------------------|---------------------|----------------------|---------------------|
| 9. $876 \div 2$ | 10. $9,473 \div 5$ | 11. $396 \div 24$ | 12. $8,911 \div 45$ |
| 13. $700 \div 12$ | 14. $1,065 \div 15$ | 15. $2,737 \div 305$ | 16. $4,516 \div 22$ |

Solve each problem, showing all work.

| | |
|---|--|
| 17. Mrs. Kleim bought 5 boxes of 15 pencils to give to her students. If she has 26 students in her class, how many pencils can she give each student? How many pencils will she have left over? | 18. Sarah and her 3 friends split a bag of candy evenly. They each ate 13 pieces of candy and there were 2 pieces leftover. How many pieces of candy were originally in the bag? |
|---|--|

Rounding with Whole Numbers & Decimals

| | | | | | | | | |
|---------------|-----------|----------|------|------|---|--------|------------|-------------|
| — | — | — | — | — | ● | — | — | — |
| ten-thousands | thousands | hundreds | tens | ones | | tenths | hundredths | thousandths |

1. Keep all digits to the left of the place you are rounding the same
2. If the digit to the right of the rounding digit is less than 5, keep the rounding digit the same. If it's 5 or greater, increase the rounding digit by 1.
3. Change all places to the right of the digit you are rounding to 0. (Trailing zeros after the decimal are unnecessary)

ex: round 52.943 to the nearest tenth

52.943
less than 5, so the 9 stays the same

52.900
don't need trailing zeros after the decimal

52.9

Word Form & Expanded Form

1. Word Form: write the whole number in word form, translate the decimal to "and", & write the decimal as if it were a whole number, followed by the name of the place of the last digit
2. Expanded Form: write the value of each non-zero digit separately, with addition signs between them

ex: 209.315

two hundred nine **and** three hundred fifteen **thousandths**

$200 + 9 + 0.3 + 0.01 + 0.005$

Comparing & Ordering Decimals

1. Compare the whole number portions of the numbers. If they are different write $>$ for greater than or $<$ for less than.
2. If the whole numbers are the same, compare each digit to the right of the decimal point, one at a time until you find digits that are different. (If necessary, add zeros at the end of a decimal.)

ex: $13.702 \bigcirc 13.74$

$13 = 13$

$13.7 = 13.7$

$13.70 < 13.74$

So, $13.702 < 13.74$

Round the number 21,498.2536 to the nearest indicated place.

| | | | |
|--------------|---------------|----------------|------------------|
| 19. tenth | 20. hundred | 21. thousandth | 22. one |
| 23. thousand | 24. hundredth | 25. ten | 26. ten-thousand |

Complete the chart below.

| Standard Form | Expanded Form | Word Form |
|---------------|-----------------------------------|---|
| 3.962 | 27. | 28. |
| 29. | 100 + 2 + 0.09 | 30. |
| 31. | 32. | Five thousand six hundred eighty-five and twelve hundredths |
| 8,770.006 | 33. | 34. |
| 35. | 900 + 10 + 4 + 0.3 + 0.02 + 0.008 | 36. |
| 37. | 38. | Two thousand nine and thirty-five thousandths |

Compare each pair of numbers by writing <, >, or = in the provided circle.

| | | | |
|---------------------|---------------------|-----------------------|-----------------------|
| 39. 0.046 ○ 0.13 | 40. 9.52 ○ 90.13 | 41. 24.13 ○ 24.130 | 42. 15.96 ○ 15.906 |
| 43. 0.964 ○ 1 | 44. 6.83 ○ 6.825 | 45. 7.256 ○ 7.24 | 46. 32.9 ○ 3.290 |

Order the numbers from least to greatest.

| | |
|------------------------------|-------------------------------------|
| 47. 6.86, 6.8, 7, 6.9, 6.827 | 48. 12.03, 1.2, 12.3, 1.203, 12.301 |
|------------------------------|-------------------------------------|

Adding & Subtracting Decimals

1. Write the problem vertically, lining up the decimal points
2. Add zeros, if necessary
3. Add or subtract the numbers as if they were whole numbers
4. Bring the decimal point straight down

ex: $12.8 - 1.52$

$$\begin{array}{r}
 12.\overset{7}{8}\overset{1}{0} \\
 - \quad 1.52 \\
 \hline
 11.\overset{7}{2}8
 \end{array}$$

Multiplying Decimals

1. Write the problem vertically with the numbers lined up to the right (decimals do NOT need to be lined up)
2. Ignore the decimal points and multiply the numbers as if they were whole numbers
3. Count the total number of decimal places in the two factors and put a decimal point in the product so that it has that same number of decimal places

ex: 3.24×0.8

$$\begin{array}{r}
 \overset{1}{3}.\overset{3}{2}4 \rightarrow 2 \text{ decimal places} \\
 \times \quad 0.8 \rightarrow 1 \text{ decimal place} \\
 \hline
 2592 \\
 \hline
 2.\overset{3}{5}92
 \end{array}$$

3 decimal places

Dividing Decimals

1. Write the dividend under the division symbol and the divisor in front of the division symbol
2. Move the decimal in the divisor after the number and then move the decimal in the dividend the same number of places and bring it up
3. Ignore the decimal point and divide as if whole numbers
4. If there is a remainder, add a zero to the end of the dividend, bring it down, and then continue dividing until there is no remainder

ex: $32.3 \div 0.5$

$$\begin{array}{r}
 \boxed{64.6} \\
 0.5 \overline{) 32.30} \\
 \underline{-30} \\
 23 \\
 \underline{-20} \\
 30 \\
 \underline{-30} \\
 0
 \end{array}$$

Find each sum or difference. Show your work.

| | | | |
|--------------------|-------------------|----------------------|-----------------------|
| 49. $8.74 + 10.36$ | 50. $37.4 - 8.55$ | 51. $12.9 + 105.67$ | 52. $450.89 - 213.33$ |
| 53. $24.1 + 3.74$ | 54. $14.76 - 9.8$ | 55. $622.85 + 53.49$ | 56. $67 - 14.06$ |

Find each product or quotient. Show your work.

| | | | |
|----------------------|---------------------|------------------------|---------------------|
| 57. 4.5×6 | 58. $144.8 \div 4$ | 59. 2.7×0.8 | 60. $6.2 \div 0.04$ |
| 61. 8.9×2.5 | 62. $15.8 \div 0.5$ | 63. 14.8×0.12 | 64. $16.2 \div 1.2$ |

Solve each problem, showing all work.

| | |
|---|--|
| 65. Ryan spent \$3.25 on lunch every day, Monday through Friday. If he had \$20 at the start of the week, how much money did he have left after Friday? | 66. Three friends went out to lunch. The bill came to \$47.31. If they split the bill evenly, how much money does each friend owe? |
|---|--|

Adding & Subtracting Fractions

1. Rename the fractions to equivalent fractions with common denominators
2. Add or subtract the numerators and keep the denominator the same
3. If mixed numbers, add or subtract the whole numbers
4. If possible, simplify the answer & change improper fractions to mixed numbers

ex: $4\frac{4}{9} + \frac{2}{3}$

$$\begin{array}{r} 4\frac{4}{9} \times \frac{1}{1} = \frac{4}{9} \\ + \frac{2}{3} \times \frac{3}{3} = \frac{6}{9} \\ \hline \end{array}$$

$$4 \frac{10}{9} = \boxed{5 \frac{1}{9}}$$

Multiplying Fractions

1. Turn a whole number into a fraction by giving it a denominator of 1
2. Cross-simplify the fractions if possible
3. Multiply the 2 numerators and the 2 denominators
4. If possible, simplify the answer & change improper fractions to mixed numbers

ex: $6 \times \frac{2}{3}$

$$\begin{array}{r} \cancel{2} \overline{6} \times \frac{2}{\cancel{3}} = \frac{4}{1} \end{array}$$

$$= \boxed{4}$$

Dividing Fractions

1. Turn a whole number into a fraction by giving it a denominator of 1
2. Keep the 1st fraction the same, change the division symbol to multiplication, and flip the 2nd fraction to its reciprocal
3. Multiply the 2 fractions
4. If possible, simplify the answer & change improper fractions to mixed numbers

ex: $12 \div \frac{1}{2}$

$$\frac{12}{1} \div \frac{1}{2}$$

$$\frac{12}{1} \times \frac{2}{1} = \frac{24}{1} = \boxed{24}$$

Find each sum or difference. Show your work.

| | | | |
|-----------------------------------|-------------------------------------|-----------------------------------|-------------------------------------|
| 67. $\frac{7}{8} + \frac{5}{6}$ | 68. $\frac{9}{10} - \frac{1}{2}$ | 69. $\frac{3}{11} + \frac{2}{3}$ | 70. $\frac{11}{12} - \frac{13}{18}$ |
| 71. $4\frac{5}{9} + 7\frac{1}{3}$ | 72. $12\frac{9}{14} - 9\frac{3}{7}$ | 73. $3\frac{3}{5} + 2\frac{3}{4}$ | 74. $2\frac{2}{15} - 1\frac{2}{3}$ |

Find each product or quotient. Show your work.

| | | | |
|--------------------------------------|--------------------------|---------------------------------------|--------------------------|
| 75. $\frac{1}{6} \times \frac{3}{4}$ | 76. $6 \div \frac{1}{3}$ | 77. $15 \times \frac{2}{3}$ | 78. $\frac{1}{2} \div 3$ |
| 79. $\frac{1}{6} \times 10$ | 80. $\frac{1}{4} \div 2$ | 81. $\frac{5}{9} \times \frac{3}{20}$ | 82. $4 \div \frac{1}{5}$ |

Solve each problem, showing all work.

| | |
|--|---|
| 83. Jacqui ran $1\frac{1}{2}$ miles on Monday, Wednesday, and Friday and $\frac{3}{4}$ mile on Tuesday and Thursday. How far did she run in all? | 84. Tyrell gave 3 packs of baseball cards to his friends. He gave each friend $\frac{1}{3}$ of a pack. How many friends got baseball cards? |
|--|---|

The Metric System

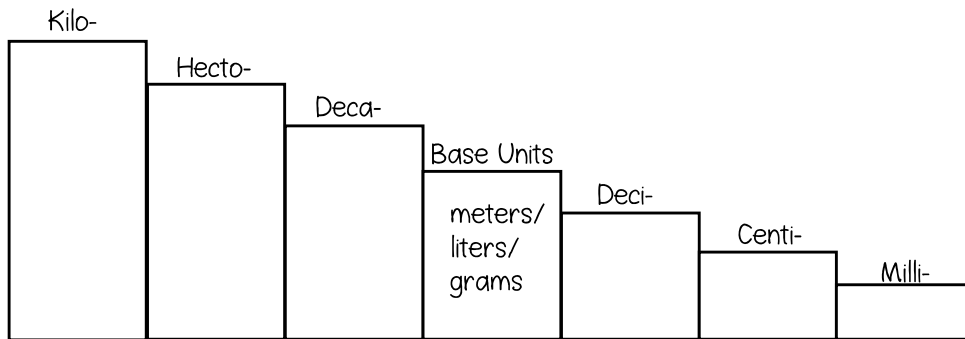

ex: $23 \text{ m} = \underline{\hspace{2cm}} \text{ cm}$

going from base unit step to centi- step, so need to move the decimal 2 places right

$$23 \overset{\cdot}{\underset{\cdot}{00}} \\ = \boxed{2,300 \text{ cm}}$$

Determine the direction and count the number of steps it takes to get from the starting unit to the unit you are converting to and move the decimal point the same number of places in that direction.

The Customary System

| Length | Weight | Capacity |
|-----------------|----------------|---------------|
| 1 ft = 12 in | 1 lb = 16 oz | 1 c = 8 fl oz |
| 1 yd = 3 ft | 1 T = 2,000 lb | 1 pt = 2 c |
| 1 mi = 5,280 ft | | 1 qt = 2 pt |
| | | 1 gal = 4 qt |

ex: $18 \text{ c} = \underline{\hspace{2cm}} \text{ pt}$

cups are smaller units of measure than pints, so need to divide

$$18 \div 2 = \boxed{9 \text{ pints}}$$

To convert from a larger unit to a smaller unit, multiply. To convert from a smaller unit to a larger unit, divide.

Volume

Volume is the number of cubic units inside a figure.

Volume of Rectangular Prism = length x width x height

Volume of Irregular Figure: count cubic units

ex: find the volume

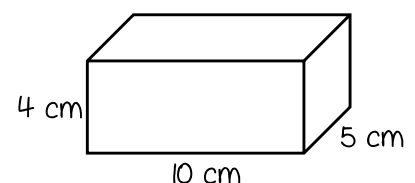

$$V = 4 \times 10 \times 5 = \boxed{200 \text{ cm}^3}$$

Convert each Metric measurement. Show your work.

| | | |
|------------------------|---------------------|-----------------------|
| 85. 1.9 km = _____ m | 86. 23 g = _____ mg | 87. 350 ml = _____ kl |
| 88. 0.07 kg = _____ cg | 89. 6 cm = _____ m | 90. 35 ml = _____ l |

Convert each Customary measurement. Show your work.

| | | |
|-----------------------|-----------------------|----------------------|
| 91. 48 in = _____ ft | 92. 6 pt = _____ c | 93. 3 T = _____ lb |
| 94. 1.5 mi = _____ ft | 95. 32 pt = _____ gal | 96. 32 oz = _____ lb |

Find the volume of each figure. Show your work.

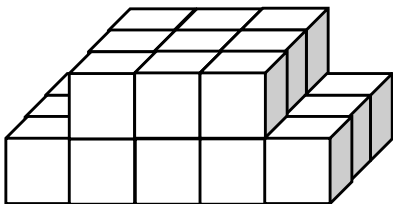
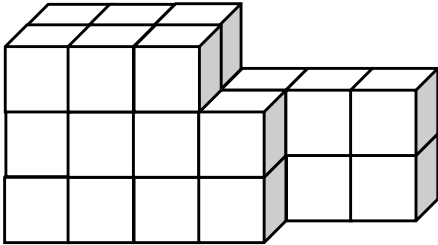
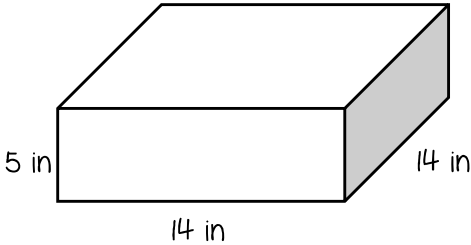
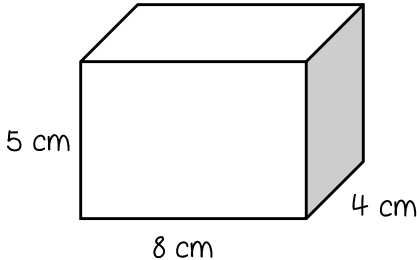
| | |
|--|--|
| <p>97.</p>  | <p>98.</p>  |
| <p>99.</p>  | <p>100.</p>  |