

# CO/PRO<sup>®</sup> 3DA1 CARBON MONOXIDE (CO) SHUTOFF SWITCH

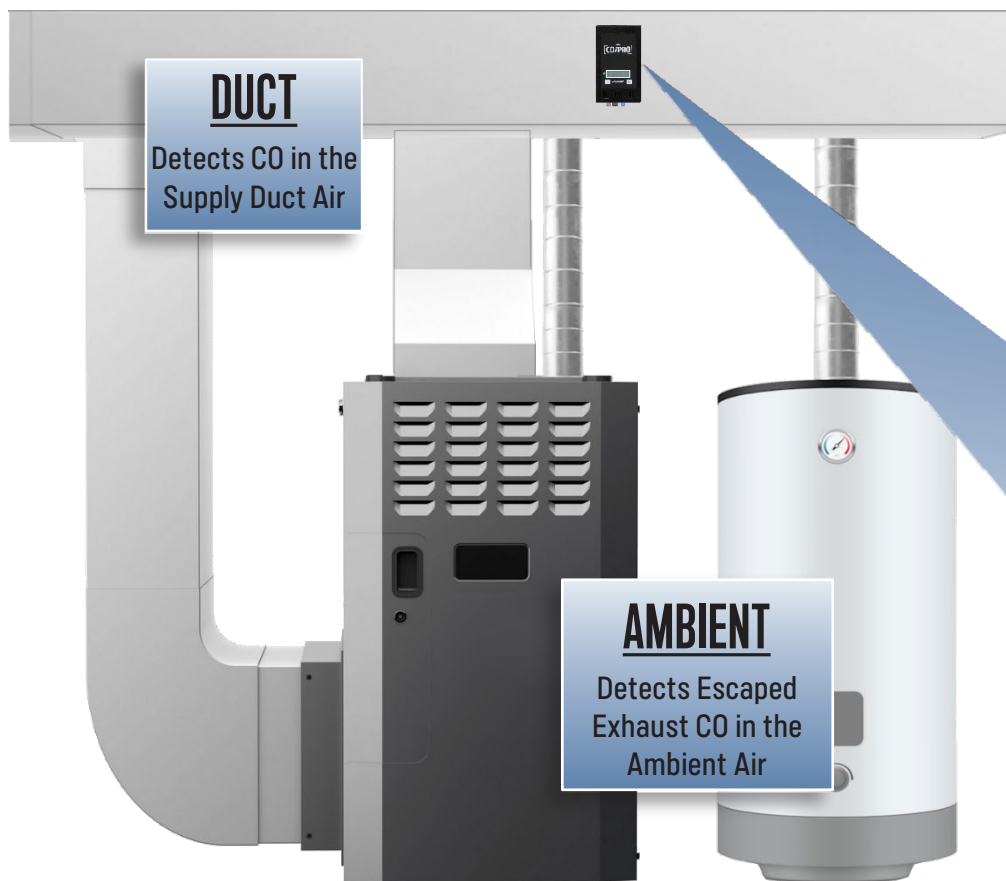

**CO/PRO<sup>®</sup>**  
**Dual CO Sensors.**  
**Smarter Protection.**  
**Greater Peace of Mind.**



The **CO/PRO<sup>®</sup>** from Respiro is a dual sensor carbon monoxide (CO) **shutoff switch** that monitors new and existing furnaces and water heaters and turns them off when CO is detected—**immediately stopping the production of CO at the source!**

Each year, over **100,000** people visit emergency rooms, and **1,000** lives are lost to CO poisoning. Traditional CO detectors, usually placed in central areas in homes, alert occupants **after the CO has spread** from the CO source to the detector. A CO detector's first alarm occurs at **70 ppm** and alarms from 70-149 ppm are delayed 1-4 hours.

The **CO/PRO<sup>®</sup>** takes a proactive approach to CO by directly monitoring fuel-burning furnaces and water heaters. When the CO/PRO detects just 25 ppm, it automatically shuts off the appliances. When levels decrease to 15 ppm, it reapplies power to them.

The **CO/PRO<sup>®</sup>** is two CO monitors in one. Equipped with dual **UL-2075** rated CO sensors, it monitors CO levels in the furnace supply duct while simultaneously monitoring for CO in the ambient air near the exhaust systems.

The CO/PRO delivers peace of mind for you and your family—even when you're not home.

When it comes to CO safety, **Don't just detect... PROtect!**<sup>™</sup>

## CO/PRO KEY FEATURES:

- Proactive monitoring for CO in the supply duct and from the exhaust systems
- Two UL-2075 compliant sensors
- Intelligent appliance power control
- Easy 15-20 minute installation
- Automatic daily self test
- Up to 10-year sensor life
- Audible and visual alarm indicators
- 24 VAC powered
- Patented operation
- 1 year warranty (2 years when registered)
- Made in the USA using imported parts!

**Respiro**

30 N. Gould Street,  
Suite 23958  
Sheridan, Wyoming 82801  
**307-381-7000**

[www.Respiro-USA.com](http://www.Respiro-USA.com)  
[ContactUs@Respiro-USA.com](mailto:ContactUs@Respiro-USA.com)



# INTERFACE

**Display Position 1**

- A=Ambient, d=Duct

**Status LED**

**Function Buttons**

- A/D = Ambient/duct, Current & Peak CO
- Mute = Mute audible alarm, Test

**Display Position 2**

- "P" = Peak CO, " " = Current CO

**Display Positions 3 & 4**

- CO Level (ppm)
- 0 - 99 ppm

**Mini Display**

- Temperature (°F)

# SPECIFICATIONS

**Dimensions:** 3.5 in(89mm) W x 6.3 in (160mm) H x 9.7 in (246mm) D

**Mounting Location:** Supply duct, 6ft from the duct bend/source

**Power:** 20–30 VAC, < 5 Watts

**Relays:** Two Dry SPDT-NC (Form B) 5A at 24 VAC

**CO Alarm Activation Level:** 25 ppm

CO Relay Reset Level: 15 ppm

**CO Sensor/Display Range:** 0 - 99 ppm

**Response time:** < 90 seconds from 10% to 90% of range

**Accuracy:** + 5 ppm @ 0-25 ppm, + 10 ppm @ 26-100 ppm

Operational Temperature: (20 to 70°C)

Storage Temperature: (-20 to 70°C)

**Relative Humidity:** (5-99%, non-condensing)

Case: Polycarbonate UL94 V0

\* Specifications are subject to change. Contact Respiro for the latest specifications.

\*\* Appliances shown are not included.

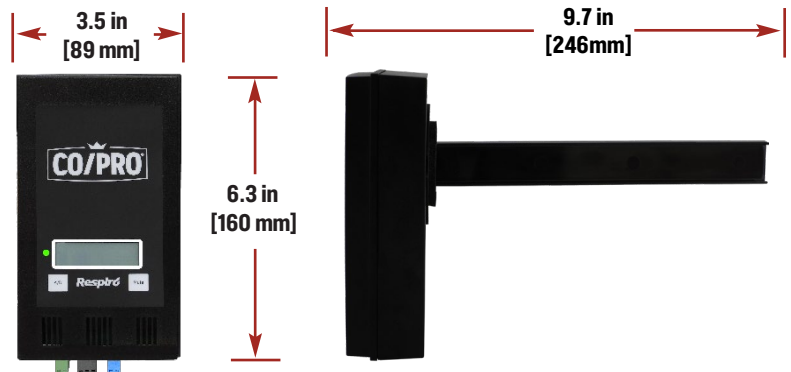

# CONNECTIVITY



**Single Family**



**Multi-Family**

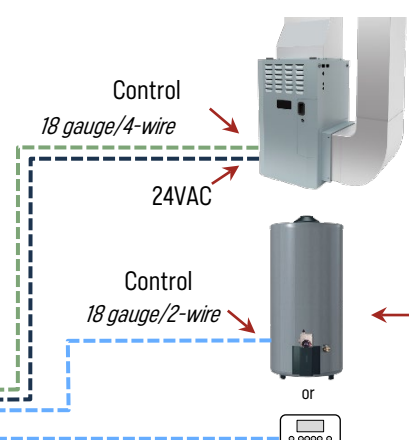

**Furnaces**  
Single, Dual, and Variable Stage

**Water Heaters (Tank)**  
Manual Pilot or Electronic Ignition



**Home Alarm System**  
(normally closed contact)

**Connectors:** **BLUE** = Water Heater or Alarm System      **BLACK** = 24V AC/DC      **GREEN** = Furnace



30 N. Gould Street,  
Suite 23958  
Sheridan, Wyoming 82801  
**307-381-7000**

[www.Respiro-USA.com](http://www.Respiro-USA.com)  
[ContactUs@Respiro-USA.com](mailto:ContactUs@Respiro-USA.com)

