

TUCS MODEL TEDR-2000 1 TON HOIST & RAIL

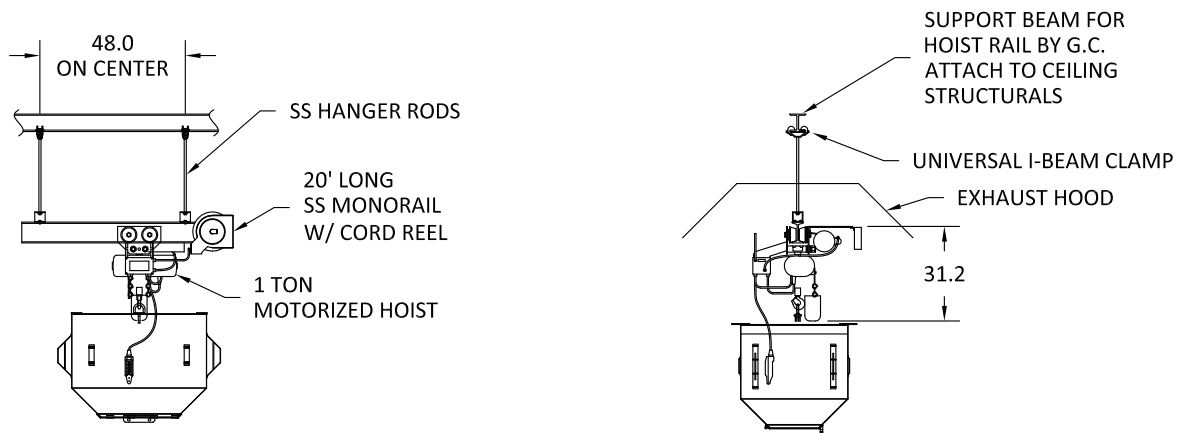

1 TON HOIST

CAPACITY: 2000 LBS
 LIFT HEIGHT: 10 FEET
 TROLLEY SPEED: 60 FPM (SINGLE SPEED)
 SOFT START FOR TROLLEY INCLUDED
 LIFT SPEED: 20 FPM (SINGLE SPEED)
 TRAM RAIL SIZE: S6 I-BEAM (3.33 FLANGE)
 STAINLESS STEEL MOTOR, BRAKE, AND GEARBOX WITH FOOD GRADE LUBRICATION
 NEMA 4X STAINLESS STEEL ENCLOSURE WITH CONTROLS
 5 BUTTON (E-STOP/UP/DN/FWD/REV) NEMA 4X PENDANT WITH 8 FOOT DROP
 PADDLE STYLE UPPER LIMIT SWITCH
 TRAM RAIL FINISH: GLASS BEAD BLAST
 VOLTAGE: 230/3/60

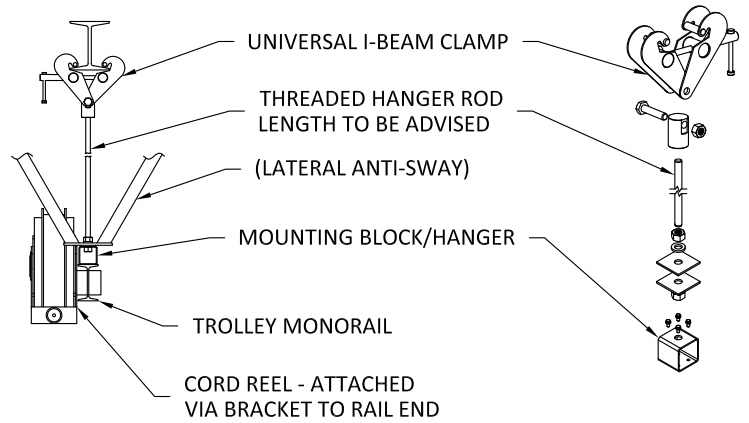

HANGER DETAIL

NOTES

- UNIVERSAL CLAMP, HANGER RODS, AND END STOPS PROVIDED LOOSE BY TUCS EQUIPMENT.
- CEILING BEAM, MONORAIL, AND KETTLE AXES MUST BE PARALLEL AND ALIGN VERTICALLY.

