

TUCS MODEL TECONV-L75-XX MOBILE 75° LIFT CONVEYOR

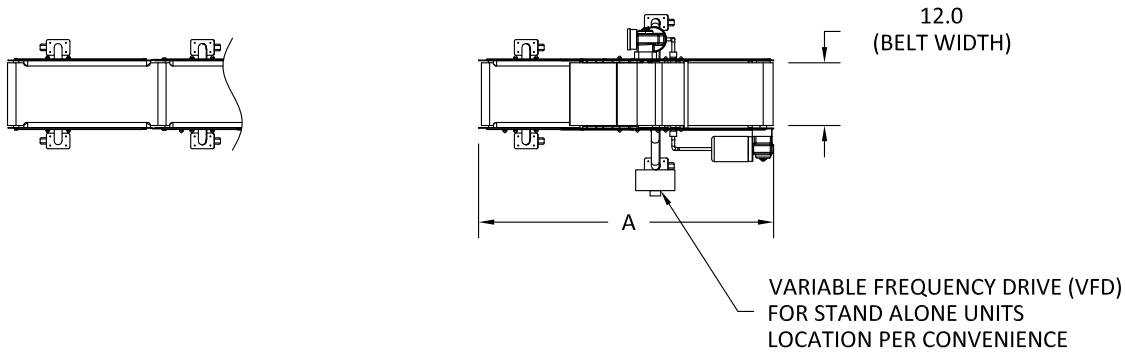

OPTIONAL EXTENSION
AVAILABLE IN
30.0" AND 42.0" LENGTHS
FOR ALL LIFT CONVEYORS

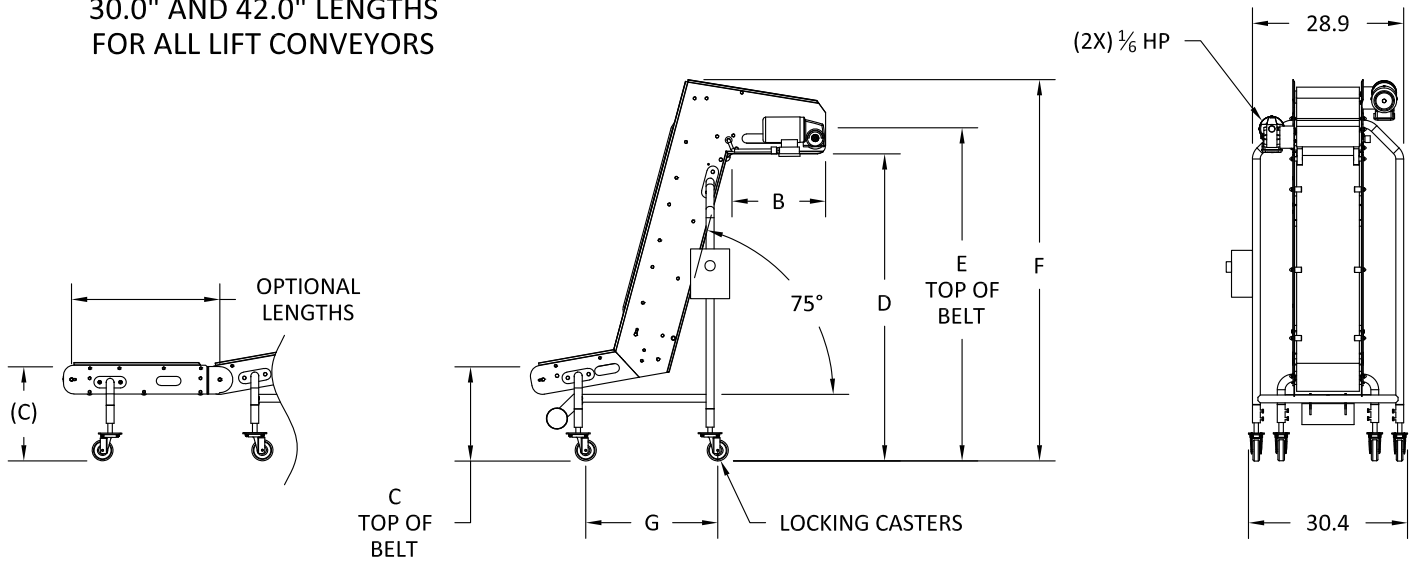

DIMENSIONS

MODEL #	A	B	C	D	E	F	G
TECONV-L75-SN	45.4	10.5	18.6	48.1	52.9	62.0	22.6
TECONV-L75-RN	56.5	19.0	18.6	60.5	65.5	74.7	25.2
TECONV-L75-CN	ON APPLICATION						

NOTES:

1. LEG HEIGHT ADJUSTABLE $\pm 2.0"$.
2. HEIGHT ADJUSTMENT WILL EFFECT DIMENSIONS C, D, E, AND F SIMULTANEOUSLY.
3. 10' STANDARD LENGTH CORD WITH PLUG AND MATCHING RECEPTACLE INCLUDED WITH LEG MOUNTED VFD.

ELECTRICAL REQUIREMENTS LEG MOUNTED VFD (1 PHASE/60 HZ)	
VOLTS	AMPS
120	7.4
208/230	4.5

ELECTRICAL REQUIREMENTS PANEL MOUNTED VFD (3 PHASE/60 HZ)	
VOLTS	AMPS
208	2.0
240	1.8
480	0.9